

**FUNCTIONAL DESCRIPTION OF THE SIGNALLING SYSTEM
(MESSAGE TRANSFER PART - MTP)
RECOMMENDATION Q.701**

CONTENTS

| | |
|---|----|
| Contents | i |
| List of Figures | ii |
| | |
| 1. GENERAL | 1 |
| | |
| 2. SIGNALLING SYSTEM STRUCTURE | 2 |
| 2.1 Basic Functional Division | 2 |
| 2.2 Functional Levels | 2 |
| 2.3 Signalling Message | 5 |
| 2.4 Functional Interface | 5 |
| | |
| 3. SIGNALLING NETWORK | 6 |
| 3.1 Basic Concepts and Features | 6 |
| 3.2 Signalling Message Handling Functions | 9 |
| 3.3 Signalling Network Management Functions | 10 |
| 3.4 Testing and Maintenance Functions | 12 |
| 3.5 Use of the Signalling Network | 12 |
| | |
| 4. MESSAGE TRANSFER CAPABILITY | 13 |
| 4.1 General | 13 |
| 4.2 User Location in System Structure | 13 |
| 4.3 Message Content | 13 |
| 4.4 User Accessibility | 14 |
| 4.5 Transport Service Performance | 14 |

**FUNCTIONAL DESCRIPTION OF THE SIGNALLING SYSTEM
(MESSAGE TRANSFER PART - MTP)
RECOMMENDATION Q.701**

LIST OF FIGURES

| | | |
|----------|--|---|
| Figure 1 | Q.701. Functional diagram for the common channel signalling system | 2 |
| Figure 2 | Q.701. General structure of signalling system functions | 3 |
| Figure 3 | Q.701. Functional interface between the message transfer part and the higher parts | 6 |
| Figure 4 | Q.701. Examples of associated and quasi-associated signalling | 8 |
| Figure 5 | Q.701. Detailed structure of signalling system functions | 9 |

I. GENERAL

The overall objective of the Signalling System No. 7 Message Transfer Part (MTP) is to provide an internationally standardized general purpose common channel signalling system that provides a reliable means of information transfer, in correct sequence, and without loss or duplication.

The signalling system is optimized for operation over 56 or 64 kbit/s digital channels. The system is suitable for use on point-to-point terrestrial and satellite links. It does not include the special features required for use in point-to-multipoint operation but can, if required, be extended to cover such an application.*

The signalling system uses signalling links for transfer of signalling messages between exchanges or other nodes in the telecommunication network served by the system. Arrangements are provided to ensure reliable transfer of signalling information in the presence of transmission disturbances or network failures. These include error detection and correction on each signalling link. The system is normally applied with redundancy of signalling links, and it includes functions for automatic diversion of signalling traffic to alternative paths in case of link failures. The capacity and reliability for signalling may thus be dimensioned by provision of a multiplicity of signalling links according to the requirements of each application.

An asterisk (*) indicates a change from the CCITT Red Book, Vol. VI.

* Text from the CCITT Red Book Vol. VI related to a general overview of Signalling System No. 7 has been deleted from Q.701 section I and moved to the Overview section I.

FUNCTIONAL DESCRIPTION OF THE SIGNALLING SYSTEM MTP

2. SIGNALLING SYSTEM STRUCTURE

2.1 Basic Functional Division

The fundamental principle of the signalling system structure is the division of functions into separate modules or entities. These consist of a common Message Transfer Part (MTP) and users of the MTP which as illustrated in Figure 1 Q.701. *

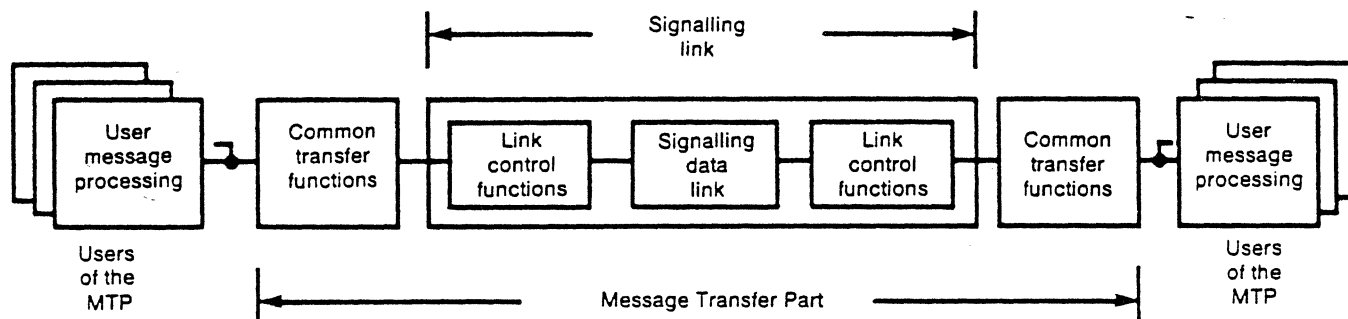

Figure 1/Q.701 -
Functional diagram for the common channel signalling system

The overall function of the Message Transfer Part is to serve as a transport system providing reliable transfer of signalling messages between the locations of communicating user or application functions. *

The term "user," in this context, refers to any functional entity that utilizes the transport capability provided by the Message Transfer Part. *

The basic commonality in signalling for different services resulting from this concept is the use of a common transport system: i.e., the Message Transfer Part. Also, a degree of commonality exists between certain users. *

2.2 Functional Levels

2.2.1 General

As a further separation, the necessary elements of the signalling system are specified in accordance with a concept in which the functions of the Message Transfer Part are separated into three functional levels, and users of the MTP exist at the higher functional levels. *

The level structure is illustrated in Figure 2/Q.701.

The system structure shown in Figure 2/Q.701 is not a specification of an implementation of the system. The functional boundaries B, C and D may or may not exist as interfaces in an implementation. The interactions by means of controls and indications may be direct or via other functions. However, the structure shown in Figure 2/Q.701 may be regarded as a possible model of an implementation.

FUNCTIONAL DESCRIPTION OF THE SIGNALLING SYSTEM MTP

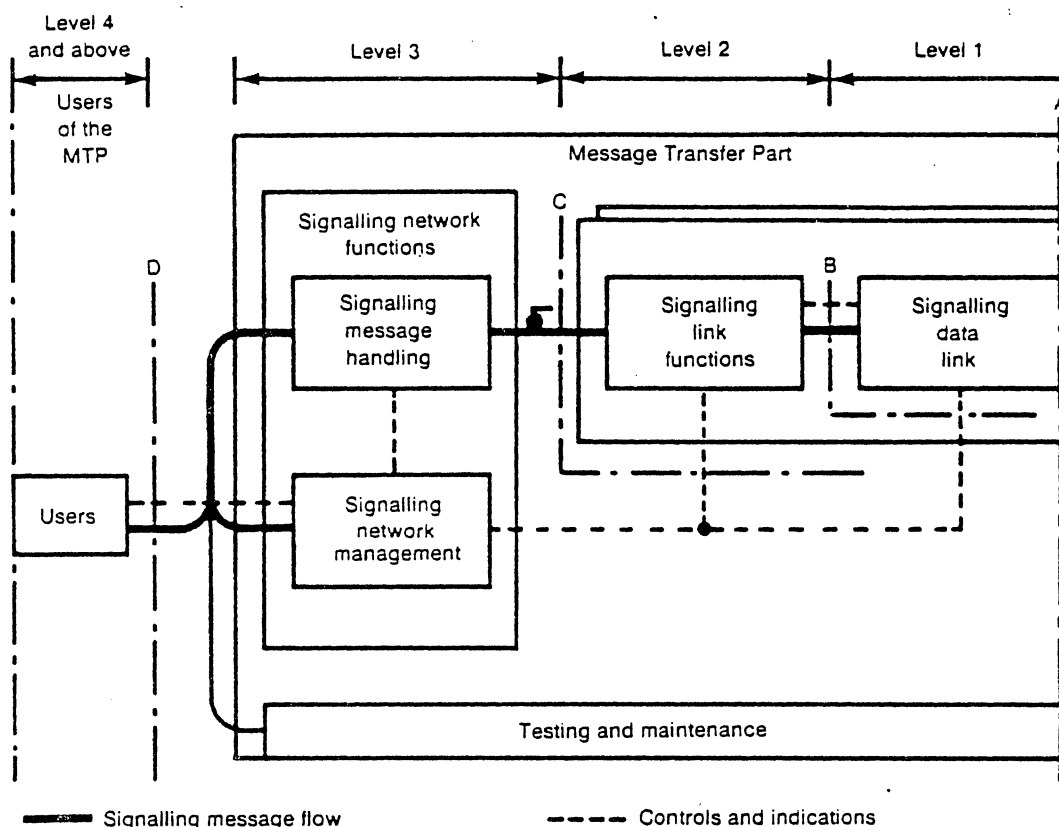

Figure 2/Q.701 -
General structure of signalling system functions

2.2.2 Signalling Data Link Functions (Level 1)

Level 1 defines the physical, electrical and functional characteristics of a signalling data link and the means to access it. The level 1 element provides a bearer for a signalling link. In a digital environment, 56 or 64 kbit/s digital paths will normally be used for the signalling data link. The signalling data link may be accessed via a switching function, providing a potential for automatic reconfiguration of signalling links. Other types of data links, such as analog links with modems, can also be used.

The detailed requirements for signalling data links are specified in Recommendation Q.702.

FUNCTIONAL DESCRIPTION OF THE SIGNALLING SYSTEM MTP

2.2.3 Signalling Link Functions (Level 2)

Level 2 defines the functions and procedures for, and relating to, the transfer of signalling messages over one individual signalling data link. Signalling data link, as a bearer, provides a signalling link for reliable transfer of signalling messages between two points.

A signalling message delivered by the higher levels is transferred over the signalling link in variable length signal units. For proper operation of the signalling link, the signal unit comprises transfer control information in addition to the information content of the signalling message.

The signalling link functions include:

- delimitation of signal unit by means of flags:
- flag imitation prevention by bit stuffing:
- error detection by means of check bits included in each signal unit; separate item error correction by retransmission and signal unit sequence control by means of explicit sequence numbers in each signal unit and explicit continuous acknowledgements:
- signalling link failure detection by means of signal unit error rate monitoring and signalling link recovery by means of special procedures.

The detailed requirements for signalling link functions are given in Recommendation Q.703.

2.2.4 Signalling Network Functions (Level 3)

Level 3, in principle, defines those transport functions and procedures that are common to, and independent of, the operation of individual signalling links. As illustrated in Figure 2 Q.701, these functions fall into two major categories:

- a) signalling message handling functions - these are functions that, at the actual transfer of a message, direct the message to the proper signalling link or higher level function: *
- b) signalling network management functions - these are functions that, on the basis of predetermined data and information about the status of the signalling network, control the current message routing and configuration of signalling network facilities. In the event of changes in the status, they also control reconfigurations and other actions to preserve or restore the normal message transfer capability.

The different level 3 functions interact with each other and with the functions of other levels by means of indications and controls as illustrated in Figure 2/Q.701. This figure also shows that the signalling network management, as well as the testing and maintenance actions, may include exchange of signalling messages with corresponding functions located at other signalling points. Although not User or Application Parts, these parts of level 3 can be seen as serving as "Users of the Message Transfer Part." As a convention in these specifications, for each description, general references to Users, as sources or sinks of signalling message, implicitly include these parts of level 3 unless the opposite is evident from the context or explicitly stated.

A description of the level 3 functions in the context of a signalling network is given in Section 3 below. The detailed requirements for signalling network functions are given in Recommendation Q.704. Some means for testing and maintenance of the signalling network are provided, and the detailed requirements are given in Recommendation Q.707.

FUNCTIONAL DESCRIPTION OF THE SIGNALLING SYSTEM MTP

2.2.5 User Functions (level 4 and above)

Levels 4 and above consist of the different users of the MTP. Each user defines the functions and procedures of the signalling system that are needed by that user. *

(Additional information on users can be found in section 2.2.2 of the Overview chapter in this specification.) *

2.3 Signalling Message

A signalling message is an assembly of information, defined at level 3 or higher, pertaining to a call, management transaction, etc., that is transferred as an entity by the message transfer function.

Each message contains *service information* including a *service indicator* identifying the user of the MTP, whether the message relates to international or national applications, and message priority. *

The "signalling information" of the message includes the actual user or application information — such as one or more telephone or data call control signals, management and maintenance information, etc. — and information identifying the type and format of the message. It also includes a "label" that provides information enabling the message:

— to be routed by the level 3 functions and through a signalling network to its destination, and

— to be directed at the destination to the particular user to whom the message is related. *

On the signalling link, each signalling message is packed into Message Signal Units (MSUs), which also include transfer control information related to the level 2 functions of the link.

2.4 Functional Interface

The following functional interface between the Message Transfer Part and its users can be seen as a model illustrating the division of functions between these parts. The interface (see Figure 3, Q.701) is purely functional and need not appear as such in an implementation of the system. *

The main interaction between the Message Transfer Part and the higher parts is the transfer of signalling messages across the interface, each message consisting of service information and signalling information as described above. Message delimitation information is also transferred across the interface with the message. *

In addition to the transfer of messages and associated information, the interaction may also include flow control information: e.g., an indication from the Message Transfer Part that it is unable to serve a particular destination.

A description of the characteristics of the Message Transfer Part, as seen from the functional interface and the requirements to be met by potential users of the message transfer function, is given in Section 4.

FUNCTIONAL DESCRIPTION OF THE SIGNALLING SYSTEM MTP

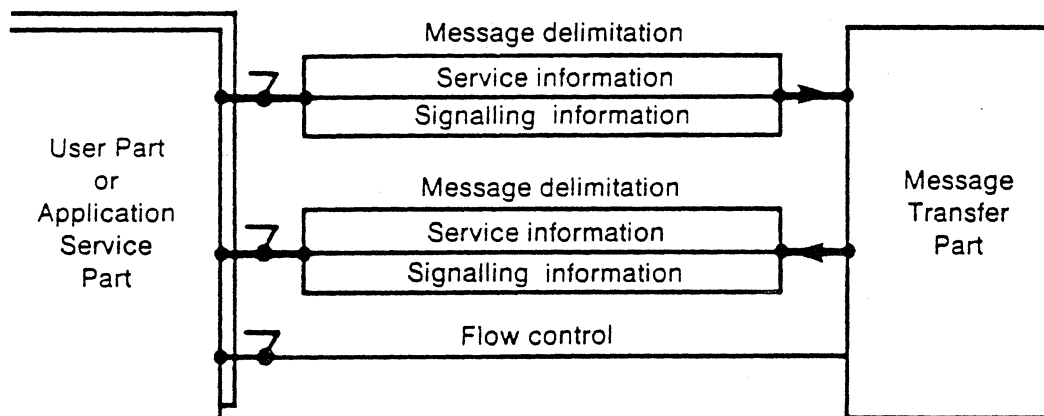

Figure 3/Q.701 -
Functional interface between the message transfer part and the higher parts *

3. SIGNALLING NETWORK

3.1 Basic Concepts and Features

3.1.1 Signalling Network Components

A telecommunication network served by common channel signalling is composed of a number of switching and processing nodes interconnected by transmission links. The nodes in the telecommunication network that are provided with common channel signalling are, in the context of signalling, referred to as "signalling points."

In specific cases, there may be a need to partition the common channel signalling functions at such a (physical) node into logically separate entities from a signalling network point of view; i.e., a given (physical) node may be defined as more than one signalling point. One example is an exchange at the boundary between the international and a national signalling network.

Any two signalling points, for which exists the possibility of communication between their corresponding User or Application Part functions, are said to have a "signalling relation."

The corresponding concept for a given User or Application Part is called "user or application signalling relation." *

An example is when two telephone exchanges are directly connected by a bundle of speech circuits. The exchange of telephone signalling relating to these circuits then constitutes a user signalling relation between the telephone user functions in those exchanges in their role as signalling points.

Another example is when administration of customer and routing data in a signalling point is remotely controlled from an operation and maintenance center by means of communication through the common channel signalling system. This communication then constitutes an application signalling relation between the applicable operation and maintenance Application Part functions at the signalling point, and the corresponding functions at the operation and maintenance center.

FUNCTIONAL DESCRIPTION OF THE SIGNALLING SYSTEM MTP

The common channel signalling system uses "signalling links" to convey the signalling messages between two signalling points. A number of signalling links that directly interconnect two signalling points that are used as a module constitute a "signalling link set." Although a link set typically includes all parallel signalling links, it is possible to use more than one link set in parallel between two signalling points (not intended for BOC networks). A group of links within a link set that have identical characteristics (e.g., the same data link bearer rate) is called a "link group."

Two signalling points that are directly interconnected by a signalling link set are, from a signalling network structure point of view, referred to as "adjacent signalling points." Correspondingly, two signalling points that are not directly interconnected are "nonadjacent signalling points."

3.1.2 Signalling Modes

The term "signalling mode" refers to the association between the path taken by a signalling message and the signalling relation to which the message refers.

In the "associated mode" of signalling, the messages relating to a particular signalling relation between two adjacent signalling points are conveyed over a link set, directly interconnecting those signalling points.

In the "non-associated mode" of signalling, the messages pertinent to a particular signalling relation are conveyed over two or more link sets in tandem, passing through one or more signalling points other than those that are the origin and the destination of the messages.

The "quasi-associated mode" of signalling is a limited case of the non-associated mode where the path taken by a message through the signalling network is predetermined and, at a given point in time, fixed.

Signalling System No. 7 is specified for use in the associated and quasi-associated modes. The Message Transfer Part alone does not include features to avoid out-of-sequence arrival of messages or other problems that would typically arise in a fully non-associated mode of signalling with dynamic message routing; this would require additional services provided by the Signalling Connection Control Part.

Examples of signalling modes are illustrated in Figure 4; Q.701.

FUNCTIONAL DESCRIPTION OF THE SIGNALLING SYSTEM MTP

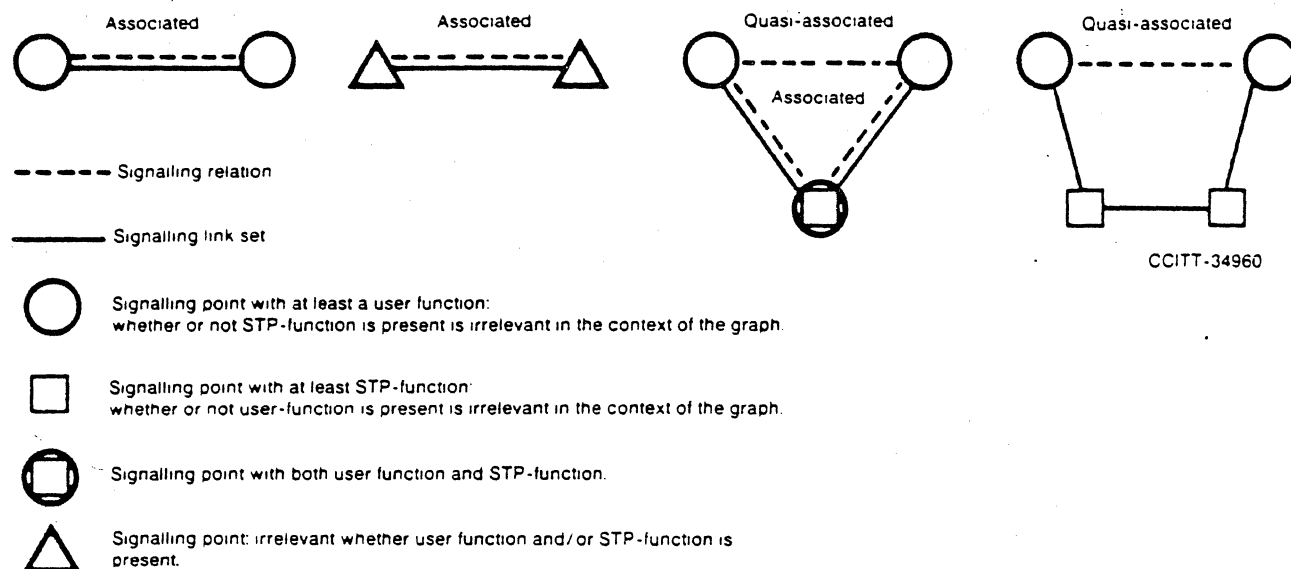

Figure 4/Q.701 -

Examples of associated and quasi-associated modes and definition of signalling network graph symbols

3.1.3 Signalling Point Modes

A signalling point at which a message is generated — i.e., the location of the source User or Application Part function — is the “originating point” of that message.

A signalling point to which a message is destined — i.e., the location of the receiving User or Application Part function — is the “destination point” of that message.

A signalling point at which a message received on a signalling link is transferred to another link — i.e., neither the location of the source nor the receiving User or Application Part function — is a “Signalling Transfer Point” (STP).

For a particular signalling relation, the two signalling points function both as origin and destination points for the messages exchanged in the two directions between them.

In the quasi-associated mode, the function of a signalling transfer point is typically located in a few signalling points that may be dedicated to this function or may combine this function with some other (e.g., switching) function. A signalling point serving as a signalling transfer point functions as an origin and a destination point for the messages generated and received by the level 3 function of the Message Transfer Part; also in cases when no user functions are present.

3.1.4 Message Labeling

Each message contains a label. In the standard label, the portion used for routing is called the “routing label.” This routing label includes:

- explicit indications of destination and origin points of the message — i.e., identification of the signalling relation concerned;
- a code used for load-sharing.

The standard routing label assumes that each signalling point in a signalling network is allocated a code according to a code plan, established for the purpose of labeling, that is unambiguous within its domain. Messages labeled according to international and national code plans are discriminated by means of an indication in the service information octet included in each message.

The standard routing label is . . . (Not applicable to U.S. networks)

3.2 Signalling Message Handling Functions

Figure 5 Q.701 illustrates the signalling message handling functions.

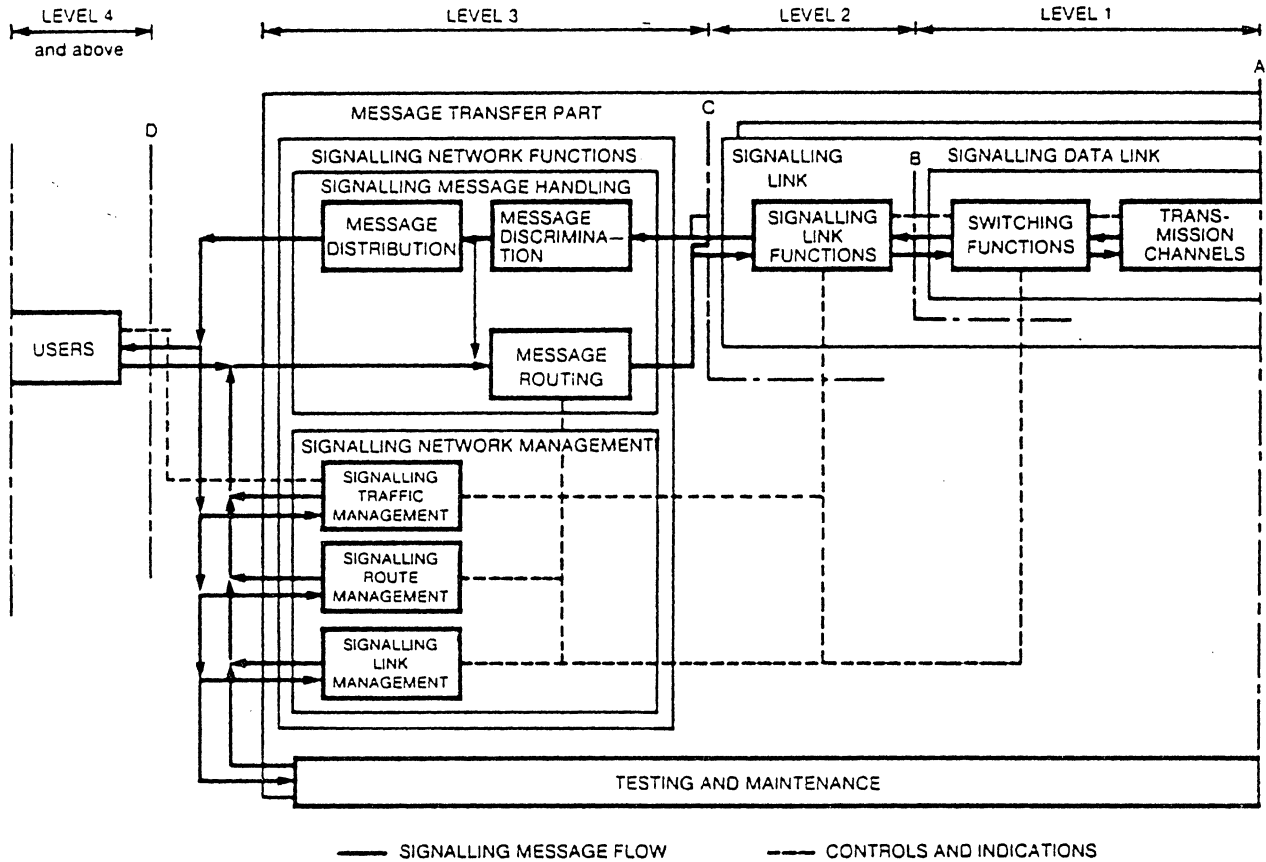

Figure 5/Q.701 -
Detailed structure of signalling system functions

FUNCTIONAL DESCRIPTION OF THE SIGNALLING SYSTEM MTP

3.2.1 Message Routing

"Message routing" is the process of selecting, for each signalling message to be sent, the signalling link to be used. In general, message routing is based on analysis of the message routing label in combination with predetermined routing data at the signalling point concerned.

Message routing is destination code-dependent, with, typically, an additional load-sharing element allowing different portions of the signalling traffic to a particular destination to be distributed over two or more signalling links. This traffic distribution may be limited to different links within a link set or applied to links in different link sets.

Each succession of signalling links that may be used to convey a message from the originating point to the destination point constitutes a "message route." "Signalling route" is the corresponding concept for a possible path, referring to a succession of link sets and signalling transfer points, between a given signalling point and the destination point.

In Signalling System No. 7, message routing is conducted such that the route taken by a message with a particular routing label is predetermined and, at a given point in time, fixed. Typically, however, in the event of failures in the signalling network, the routing of messages — previously using the failed message route — is modified in a predetermined manner under control of the signalling traffic management function at level 3.

Although there are, in general, advantages to using a uniform routing of messages belonging to different User Parts, the service indicator included in each message provides a potential for using different routing plans for different User Parts.

3.2.2 Message Distribution

"Message distribution" is the process which, upon receipt of a message at its destination point, determines to which user of the Message Transfer Part the message is to be delivered. This choice is made on analysis of the service information octet.

3.2.3 Message Discrimination

"Message Discrimination" is the process which, upon receipt of a message at a signalling point, determines whether or not the point is the destination point of that message. This decision is based on analysis of the destination code in the message routing label. If the signalling point is the destination point, the message is delivered to the message distribution function. If it is not the destination point (i.e., in the case when it serves as a signalling transfer point for that message), the message is delivered to the message routing function for further transfer to a signalling link. Thus, message discrimination is a function required only at a signalling point that acts as a signalling transfer point.

3.3 Signalling Network Management Functions

Figure 5 Q.701 illustrates the signalling network management functions.

3.3.1 Signalling Traffic Management

The tasks of the "signalling traffic management" function are:

* Text from the CCITT Red Book, Vol. VI, related to different routing plans for different user parts, was deleted from this section.

FUNCTIONAL DESCRIPTION OF THE SIGNALLING SYSTEM

- a) to control message routing — this includes modification of message routing to preserve, when required, accessibility of all destination points concerned or to restore normal routing;
- b) in conjunction with modification of message routing, to control the resulting transfer of signalling traffic in a manner that avoids irregularities in message flow; and
- c) flow control.

Control of message routing is based on analysis of predetermined information about all allowed potential routing possibilities in combination with information, supplied by the "signalling link management" and "signalling route management" functions, about the status of the signalling network (i.e., current availability of signalling links and routes).

Changes in the status of the signalling network typically result in modification of current message routing and, thus, in transfer of certain portions of the signalling traffic from one signalling link to another. The transfer of signalling traffic is performed in accordance with specific procedures — "changeover," "changeback," "forced rerouting" and "controlled rerouting" — that are designed to avoid, as far as circumstances permit, such irregularities in message transfer as loss, mis-sequencing or multiple message delivery. *

The changeover and changeback procedures involve communication with other signalling point(s). For example, in the case of changeover from a failing signalling link, the two ends of the failing link exchange information (via an alternative path) that normally enables retrieval of messages that otherwise would have been lost on the failing link. However, as further explained later, these procedures cannot guarantee regular message transfer in all circumstances.

A signalling network has to have a signalling traffic capacity that is higher than the normal traffic offered. However, in overload conditions (e.g., due to network failures or extremely high traffic peaks), the signalling traffic management function takes flow control actions to minimize the problem. An example is provision of an indication to the local higher level functions concerned that the Message Transfer Part is unable to transport messages to a particular destination in the case of total breakdown of all signalling routes to that destination point. If such a situation occurs at a signalling transfer point, a corresponding indication is given to the signalling route management function for further dissemination to other signalling points in the signalling network. *

3.3.2 Signalling Link Management

The task of the signalling link management function is to control the locally connected link sets. In the event of changes in the availability of a local link set, it initiates and controls actions aimed at restoring the normal availability of that link set.

The signalling link management function also supplies information about the availability of local links and link sets to the signalling traffic management function.

The signalling link management function interacts with the signalling link function at level 2 by receipt of signalling link status indications. It also initiates actions at level 2, such as initial alignment of an out-of-service link.

The signalling system can be applied with different degrees of flexibility in the method of signalling link provision. A signalling link may, for example, consist of a permanent combination of a signalling terminal device and a signalling data link. It is also possible to employ an arrangement in which any switched connection to the remote end may be used in combination with any local signalling terminal device. It is the task of the signalling link management function, in such arrangements, to initiate and control reconfigurations of terminal devices and signalling data links to the extent such reconfigurations are automatic. In particular,

FUNCTIONAL DESCRIPTION OF THE SIGNALLING SYSTEM MTP

terminal devices and signalling data links to the extent such reconfigurations are automatic. In particular, this involves interaction, not necessarily direct, with a switching function at level 1.

3.3.3 Signalling Route Management

Signalling route management is a function that relates only to the quasi-associated mode of signalling. Its task is to transfer information about changes in the availability or congestion status of signalling routes in the signalling network to enable remote signalling points to take appropriate signalling traffic management actions. Thus, a signalling transfer point may, for example, send messages indicating inaccessibility of a particular signalling point via that signalling transfer point, thus enabling other signalling points to stop routing messages into an incomplete route.

3.4 Testing and Maintenance Functions

Figure 5/ Q.701 illustrates that the signalling system includes some standard testing and maintenance procedures that use level 3 messages. Furthermore, any implementation of the system typically includes various implementation-dependent means for testing and maintenance of equipment concerned with the other levels.

3.5 Use of the Signalling Network

3.5.1 Signalling Network Structure

The signalling system may be used with different types of signalling network structures. The choice between different types of signalling network structures may be influenced by factors such as the structure of the telecommunication network to be served by the signalling system and administrative aspects.

In the case when the provision of the signalling system is planned purely on a per-signalling relation basis, the likely result is a signalling network largely based on associated signalling, typically supplemented by a limited degree of quasi-associated signalling for low volume signalling relations. The structure of such a signalling network is mainly determined by the patterns of the signalling relations. International signalling is an example of an application for which this approach is suitable.

Another approach is to consider the signalling network as a common resource that should be planned according to the total needs for common channel signalling. The high capacity of digital signalling links, in combination with the needs for redundancy for reliability, typically leads to a signalling network based on a high degree of quasi-associated signalling with some provision for associated signalling for high volume signalling relations. The latter approach to signalling network planning is more likely to allow exploitation of the potential of common channel signalling to support network features that require communication for purposes other than the switching of connections.

Further considerations about the use of a signalling network are given in Recommendation Q.705.

3.5.2 Provision of Signalling Facilities

In general, the most important factor for dimensioning the signalling network is the need for reliability by means of redundancy. Depending on the signalling network structure and the potential for reconfiguration of signalling equipment, the required redundancy may be provided by different combinations of:

- redundancy in signalling data links (e.g., nominated reserves or switched connections);
- redundancy in signalling terminal devices (e.g., a common pool of terminals for the whole signalling point);

FUNCTIONAL DESCRIPTION OF THE SIGNALLING SYSTEM MTP

- redundancy of signalling links within a link set (typically operating with load sharing); and
- redundancy in signalling routes for each destination (possibly operating with load sharing).

The loading capacity of a . . . (deleted as inappropriate) *

3.5.3 Application of Signalling Network Functions

The signalling network functions provided by the signalling system are designed to cater to a range of signalling network configurations. It is not necessary that all of those functions be present at all signalling points. The necessary functional content at level 3 at a particular signalling point depends, for example, on what signalling mode(s) are used, whether or not it is a signalling transfer point, what type of signalling equipment redundancy is employed, etc. It is therefore feasible to implement level 3 functions with modularity for different capabilities corresponding to different signalling network configurations. As a special case, it is even possible to apply the signalling system without using the level 3 element at all: e.g., in a small exchange or private automatic branch exchange that can only be reached via one primary pulse code modulation system.

4. MESSAGE TRANSFER CAPABILITY

4.1 General

The Message Transfer Part recommendations specify methods by which different forms of signalling networks can be established. The requirements for the Message Transfer Part have primarily been determined by the requirements of call control signalling for the telephone and circuit switched data transmission services. However, the Message Transfer Part is also intended to have the ability to serve as a transport system for other types of information transfer. The following summarizes the typical characteristics of the transport service that may be offered by the Message Transfer Part to a potential user of this capability.

All information to be transferred by the Message Transfer Part must be assembled into messages. The linking of the source and sink of a message is inherent in the label in combination with the signalling routes existing between the two locations. From a transportation point of view, each message is self-contained and individually handled. The nature of the transport service offered by the Message Transfer Part is, therefore, similar to that offered by a packet switched network. In addition, all messages containing the same label constitute a set of messages that is handled in a uniform manner by the Message Transfer Part; thus ensuring, in normal circumstances, regular delivery in the correct sequence.

4.2 User Location in System Structure

A potential user of the transport service is typically included in the system structure by provision of a separate User or Application Part. This may require allocation of a service indicator code, the specification of which is part of both the Message Transfer Part and user concerned. *

4.3 Message Content

4.3.1 Code Transparency

Information with any code generated by a user of the MTP can be transferred by the Message Transfer Part, provided that the message respects the requirements described below. *

4.3.2 Service Information

Each message must contain service information coded in accordance with the rules specified in Recommendation Q.704, Section 12.

FUNCTIONAL DESCRIPTION OF THE SIGNALLING SYSTEM MTP

4.3.3 *Message Label*

Each message must contain a label consistent with the routing label of the signalling network concerned. See also Recommendation Q.704, Section 2.

4.3.4 *Message Length*

The information content of a message should be an integral number of octets.

The total amount of signalling information transferable in one message is limited by some parameters of the signalling system; although internationally limited to about 60 octets, SS7 can accept transfer of information blocks on the order of 256 octets in single messages (see Q.703 section 2.3.8).

Depending on the signalling traffic characteristics of users or applications sharing the same signalling facilities, there may be a need to limit message lengths below the system limit based on queuing delay considerations.

In the case when generated information blocks exceed the allowed message length, it is necessary to implement means for segmentation and blocking of such information blocks.

4.4 *User Accessibility*

The accessibility of user functions through a signalling network depends on the signalling modes and routing plan employed in that network.

In the case when only the associated mode of signalling is employed, only user functions located at adjacent signalling points may be accessed.

In the case when quasi-associated signalling is employed, functions located at any signalling point may be accessed, provided that the corresponding message routing data is present.

4.5 *Transport Service Performance*

Detailed information is provided in Recommendation Q.706.

4.5.2 *Message Transfer Delay*

The normal delay for message transfer between user locations depends on factors such as distance, signalling network structure, signalling data link type and bit rate, and processing delays.

A small proportion of messages will be subject to additional delay because of transmission disturbances, network failures, etc.

4.5.2 *Message Transfer Failures*

The Message Transfer Part has been designed to enable it to transfer messages in a reliable and regular manner, even in the presence of network failures. However, some failures inevitably will occur, the consequences of which cannot be avoided with economic measures. The types of failures that may occur, and some typical probabilities of their occurrence are described below. Recommendation Q.706 provides further detailed information that can be used to estimate failure rates for particular cases.

In the case when a potential user of the Message Transfer Part requires a reliability of the transport service that cannot be guaranteed by the Message Transfer Part, the reliability for that user or application

may be enhanced by adoption of appropriate higher level procedures, possibly including some means of supplementary end-to-end error control. *

The following types of message transfer failures are possible, and expected probabilities for such failures in typical applications are indicated (see also Recommendation Q.706).

- a) Unavailability of the transport service to one or more locations — the availability of the message transfer capability depends on the redundancy provided in the signalling network; the availability can, therefore, be dimensioned.
- b) Loss of messages — the probability of message loss of mainly depends on the reliability of signalling equipment; typically, it is expected to be lower than 10^7 .
- c) Mis-sequencing of messages — may, in certain configurations of quasi-associated signalling, occur with rare combinations of independent failures and disturbances. The probability, in such configurations, of a message being delivered out-of-sequence depends on many factors, but is expected to be lower than 10^{10} .
- d) Delivery of false information — undetected errors may lead to delivery of false information; the possibility of an error in a delivered message is expected to be lower than 10^9 . *