

34380052
© 1985 APPLE
8603 CDP



Apple Service
Technical Procedures
Laser Printers
Volume Two



Apple Service Technical Procedures Laser Printers

Volume Two

PN: 072-0163

2

3

4

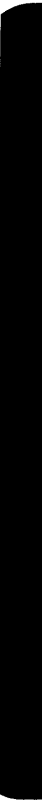



LaserWriter II

Technical Procedures

□ TABLE OF CONTENTS

Section 1 – Basics	1.3	Product Description
	1.3	LaserWriter II SC
	1.3	LaserWriter II NT
	1.3	LaserWriter II NTX
	1.3	LaserWriter II NTX-J
	1.4	LaserWriter IIf
	1.4	LaserWriter IIg
	1.4	Additional Documentation
	1.5	Parts of the Printer
	1.8	Print Engine Specifications
	1.8	General
	1.8	Electrical
	1.8	Environmental
	1.9	Physical
	1.9	Performance
	1.9	Paper
	1.10	Cassette-Feed
	1.10	Manual-Feed
	1.11	Controller-I/O Board Specifications
	1.11	General
	1.12	Fonts
	1.13	Printable Area
	1.14	Theory of Operation—Print Engine
	1.15	Main Motor
	1.16	Control System
	1.18	Laser/Scanner Assembly
	1.20	Image Formation System
	1.26	Pickup/Feed System
	1.29	Power Distribution System
	1.30	Theory of Operation—SC Controller-I/O Board
	1.30	Introduction
	1.30	Overview
	1.33	Theory of Operation—NT/NTX/NTX-J Controller-I/O Boards
	1.33	Introduction
	1.33	Overview
	1.35	NT Controller-I/O Board
	1.37	NTX/NTX-J Controller-I/O Boards

	1.41	Theory of Operation—IIf/g Controller-I/O Boards
	1.41	Introduction
	1.41	Overview
	1.47	Status LEDs
	1.48	Toner Cartridge
	1.49	Protective Shield
	1.49	Light-Blocking Shutters
	1.49	Storage
	1.50	Handling Procedure
	1.51	Setup and Operation
	1.52	Test Pages
	1.52	Engine Self-Test Page
	1.53	SC Startup Test Page
	1.53	NT/NTX Startup Test Page
	1.55	IIf/g Startup Test Page
	1.57	Electrostatic Discharge (ESD) Precautions
	1.57	Why Prevent ESD?
	1.57	ESD Rules
Section 2 – Take-Apart	2.3	Introduction
	2.3	Materials Required
	2.3	Before Beginning
	2.3	Safety Precautions
	2.4	Orientation
	2.4	Screw Types
	2.4	Plastic Assemblies
	2.4	Electrostatic Discharge Precautions
Covers and Panels	2.5	Covers and Panels
	2.5	Cover Set
	2.6	Front Panel
	2.7	Lower Right Panel
	2.7	Rear Panel
	2.7	Upper Right Panel
	2.8	Release Button
	2.8	Bottom Panel
	2.9	Lower Cover
Print Engine	2.10	Status Panel
	2.11	Fuser Assembly
	2.12	Heater Bulb
	2.19	Fuser Delivery Assembly
	2.20	Delivery Roller
	2.22	Delivery Sensing Lever

2.23	Power Supply Block
2.24	Upper Fan
2.26	Fan Bushing/Bearing
2.27	Ozone Filter
2.29	Laser/Scanner Assembly
2.31	High-Voltage Power Supply Assembly
2.34	DC Power Supply
2.37	Distribution PCA
2.38	Main Motor Assembly
2.39	Drive Gear Assembly
2.40	Transfer Guide Assembly
2.41	Separation Pad
2.42	Transfer Corona Assembly
2.43	Restrung Corona Wire
2.45	Paper Feed Assembly
2.46	Pickup Roller
2.48	Paper Feed Drive Assembly
2.50	Feeder Assembly
2.52	Feeder Guide Gear (24 Tooth)
2.53	Pressure Assembly
2.55	Paper Pickup Gear (19 Tooth)
2.57	Paper Pickup Gear (57 Tooth)
2.58	Left Hook
2.59	Left Lifter
2.60	Left Hook Guide
2.61	Right Hook
2.62	Right Lifter
2.63	Right Hook Guide
2.64	Paper Sensing Arm
2.65	Auxiliary Guide

Lower Print Engine

2.66	Controller-I/O Board
2.68	DC Controller PCA
2.71	Connector PCA
2.72	Lower Fan

Upper Print Engine

2.73	Top Cover
2.75	Main Tray
2.76	Heater Cover
2.77	Shutter Assembly
2.78	Shutter Arm
2.79	Mirror Assembly
2.82	Delivery Assembly
2.84	Delivery Coupler Assembly

- 2.85 Static Charge Eliminator
- 2.86 Preconditioning Exposure Assembly
- 2.88 Copy Tray
- 2.89 Paper Deflector

**Section 3 –
Adjustments**

No adjustments are necessary on the LaserWriter II.

**Section 4 –
Troubleshooting**

- 4.3 Introduction
- 4.3 How to Use the Troubleshooting Section
- 4.3 Troubleshooting Procedure
- 4.3 Materials Required
- 4.4 Test Pages
- 4.5 Electronic Tests
- 4.7 Environmental Considerations
- 4.7 Print Engine Image Defects
- 4.7 Toner Cartridge Image Defects
- 4.8 Preliminary Checks
- 4.8 Setup Checklist
- 4.8 Iif and Iig RAM Requirements
- 4.9 Iif/g Diagnostic Chart
- 4.10 Flowchart 1 – LaserWriter II Functional Check
- 4.12 Flowchart 2 – LaserWriter II Print Engine Check
- 4.15 Flowchart 3 – LaserWriter II Print Engine Error
- 4.16 Table A—No Power
- 4.18 Table B—Delivery Rollers Do Not Rotate
- 4.20 Table C—Communication Problems
- 4.20 Table C1—SC Controller-I/O Board
- 4.21 Table C2—NT/NTX Controller-I/O Board:
LocalTalk
- 4.22 Table C3—NT/NTX Controller-I/O Board:
RS-232 Serial
- 4.23 Table C4—Iif/g Controller-I/O Board:
LocalTalk
- 4.24 Table C5—Iif/g Controller-I/O Board:
RS-232 Serial
- 4.25 Table C6—Iig Controller-I/O Board: Ethernet
- 4.27 Table D—Heater Bulb Does Not Operate
- 4.29 Table E—Cannot Feed Paper Manually
- 4.30 Table F—Jams Detected When There Are No Jams
- 4.31 Table G—Paper Jams Are Not Detected
- 4.32 Table H—Paper-Out LED Lights When There Is
Paper
- 4.33 Table I—Paper-Out LED Doesn't Light with No
Paper
- 4.34 Table J—Preconditioning Lamps Do Not Light
- 4.35 Table K—Laser/Scanner Malfunction

4.36	Table L—Erroneous Low-Toner Indicator
4.37	Table M—Print Quality Problems
4.39	Table M1—Light Image: Whole Print
4.42	Table M2—Dark Image: Whole Print
4.43	Table M3—All-Blank Print
4.45	Table M4—Black Image
4.46	Table M5—Stained Print/Repetitive Defects
4.47	Table M6—Black Image & Horizontal White Stripes
4.47	Table M7—Stains on Back of Paper
4.48	Table M8—Dark Vertical Lines
4.48	Table M9—Sharp Horizontal Black Lines
4.49	Table M10—Vertical Fogged Stripes
4.50	Table M11—Horizontal Fogged Stripes
4.51	Table M12—Blank Spots
4.52	Table M13—Thin Vertical White Lines or Stripes
4.53	Table M14—Faulty Registration
4.54	Table M15—Poor Fusing: Image Smears Easily
4.54	Table M16—Distortion
4.55	Table M17—Waviness
4.55	Table M18—Uneven Print Density
4.56	Table M19—Foggy Print
4.56	Table M20—Horizontal Banding
4.57	Table M21—Wavy Print on Gray
4.57	Table M22—Blotchy or Ghosting Printing
4.57	Table M23—Image Does Not Print in Grayscale (LaserWriter IIf and IIfg only)
4.58	Table N—Paper Transport Problems
4.59	Table N1—No Paper Pickup
4.60	Table N2—Jams in Pickup/Transfer Area
4.61	Table N3—Jams in Separation/Feeder Guide Area
4.62	Table N4—Jams in Fuser/Delivery Area
4.63	Table N5—Sheets Stuck Together
4.63	Table N6—Wrinkles
4.64	Table O—NT/NTX ROM and SIMM Test
4.65	Laser Power Output Check
4.68	DC Controller PCA Switches and Connectors
4.68	High-Voltage Power Supply Connector Contacts
4.69	Distribution PCA Sensors, Switches, and Solenoids
—	Wiring Diagram (located in Section 8, Appendix)

**Section 5 –
Preventive
Maintenance**

- 5.3 Introduction
- 5.3 Before Beginning
- 5.3 Safety
- 5.3 Electrostatic Discharge Precautions
- 5.4 Setup
- 5.5 Repair Log Label
- 5.6 Maintenance Schedule
- 5.6 Schedule
- 5.7 Checking the Print Count
- 5.8 End-User Maintenance
- 5.8 Cleaning Procedures
- 5.8 Case
- 5.8 Primary Corona Wire
- 5.9 Transfer Corona Wire
- 5.9 Transfer Guide Assembly
- 5.10 Discharging Pins
- 5.10 Fuser Rollers
- 5.11 Standard Maintenance
- 5.11 Cleaning Procedures
- 5.11 Separation Claws
- 5.12 Paper Guides
- 5.12 Lower Delivery Guide
- 5.13 Transfer Corona Assembly
- 5.13 Registration Rollers
- 5.14 Feeder Guide
- 5.14 Replacing the Ozone Filter
- 5.14 Update the Repair Log
- 5.15 100,000-Copy Maintenance
- 5.15 Procedure

**Section 6 –
Additional
Procedures**

- 6.3 Controller-I/O Board Installation
- 6.3 Introduction
- 6.3 Print Engine Check
- 6.4 Configuring the Controller-I/O Board
- 6.5 Installing the Controller-I/O Board
- 6.6 Checking the Installation
- 6.9 Repackaging Checklist
- 6.9 NTX Memory Upgrade
- 6.9 SIMM Identification
- 6.10 RAM Configurations
- 6.11 RAM Upgrades
- 6.13 Iif and Iig Memory Upgrade
- 6.13 SIMM Identification
- 6.14 RAM Configurations
- 6.15 RAM Upgrades

- 6.17 NTX ROM Upgrade
 - 6.17 Introduction
 - 6.17 Installing the ROM Upgrade
 - 6.18 Checking the ROM Upgrade
- 6.20 220 V Repair and Conversion
 - 6.20 110 V to 220 V Conversion
 - 6.20 220 V to 110 V Conversion

**Section 7 –
Diagnostics**

- 7.3 Introduction
 - 7.3 LaserWriter II Test Connector
 - 7.3 ESD Precautions
- 7.4 NT/NTX ROM and SIMM Test
 - 7.4 Materials Required
 - 7.4 Before You Start
 - 7.4 Setting Up Test Station and UUT
 - 7.5 Establishing Communication
 - 7.6 Running the Test
 - 7.7 ROM Identification
 - 7.7 SIMM Identification

**Section 8 –
Appendix**

- Photo #1: Print Engine with Top Cover Removed
- Photo #2: Print Engine with Top Cover Removed
- Photo #3: Print Engine with Top Cover Open
- Photo #4: Lower Print Engine
- LaserWriter II Wiring Diagram

**Illustrated
Parts List**

- IPL.3 External Panels (Figure 1)
- IPL.5 Main Body (Figure 2)
- IPL.7 Upper Main Body (Figure 3)
- IPL.9 Bottom Case, #1 (Figure 4)
- IPL.11 Bottom Case, #2 (Figure 5)
- IPL.13 Power Cord Terminal Assembly (Figure 6)
- IPL.15 Pressure Assembly (Figure 7)
- IPL.17 Hinge Assembly (Figure 8)
- IPL.17 Gear Drive Assembly (Figure 9)
- IPL.19 Paper Feed Drive Assembly (Figure 10)
- IPL.19 Main Motor Assembly (Figure 11)
- IPL.21 Shutter Assembly (Figure 12)
- IPL.23 Cassette Holder Assembly (Figure 13)
- IPL.25 Paper Feed Roller Assembly (Figure 14)
- IPL.25 Feeder Assembly (Figure 15)
- IPL.27 Transfer Guide Assembly (Figure 16)
- IPL.29 Fixing Delivery Assembly (Figure 17)
- IPL.29 Delivery Coupler Assembly (Figure 18)

IPL.31	Transfer Corona Assembly (Figure 19)
IPL.33	Fuser Assembly, Top View (Figure 20)
IPL.35	Fuser Assembly, Exploded View #1 (Figure 21)
IPL.37	Fuser Assembly, Exploded View #2 (Figure 22)
IPL.39	Electrical Components Assembly (Figure 23)
IPL.41	High-Voltage Power Supply (Figure 24)
IPL.42	Refurbishment Kit
IPL.43	Spring Kit
IPL.45	LW II NTX Controller-I/O Board (Figure 25)
IPL.45	LW II NTX Controller-I/O Board (rev. 3) (Figure 25)
IPL.47	LW II NT Controller-I/O Board (Figure 26)
IPL.49	Cables (Figure 27)
IPL.49	Screw Kit
IPL.51	LW IIf Controller-I/O Board (Figure 28)
IPL.51	LW IIg Controller-I/O Board (Figure 29)

©Apple Computer, Inc., 1988, 1989, 1990, 1991, and 1992. No portion of this document may be reproduced in any form without the written permission of Apple Computer, Inc.

QuickDraw and TrueType are trademarks of Apple Computer, Inc.

Apple and the Apple logo, AppleTalk, EtherTalk, LaserWriter, LocalTalk, and Macintosh are registered trademarks of Apple Computer, Inc.



POSTSCRIPT
Software From Adobe PostScript and the PostScript logo are trademarks of Adobe Systems Incorporated, registered in the United States.

LaserJet is a registered trademark of Hewlett-Packard, Inc.

□ PREFACE

IMPORTANT: *You may service LaserWriter products only after you have successfully completed the Laser Printer Service Course.*

The service procedures contained in this manual provide module-level troubleshooting and repair instructions for the LaserWriter II family of printers.

Section 1, Basics, describes how the LaserWriter II works and contains illustrations locating the printer's major assemblies. Basics also presents specifications for the printer's use and maintenance, and explains the printer's test prints and status lights. Basics also contains important electrostatic discharge precautions that should be followed when working on a LaserWriter II printer.

Section 2, Take-Apart, contains step-by-step instructions for removal and replacement of LaserWriter II main modules.

Section 4, Troubleshooting, contains a systematic troubleshooting procedure and a complete set of troubleshooting tables.

Section 5, Preventive Maintenance, covers cleaning and lubrication procedures that are recommended each time you service a LaserWriter.

Section 6, Additional Procedures, provides instructions for the performance of special procedures such as memory upgrades and controller-I/O board installation.

Section 7, Diagnostics, describes how to set up and use the diagnostic program, *NT/NTX ROM and SIMM Test*.

Section 8, Appendix, contains photos of major assemblies of the LaserWriter II, and a wiring diagram of the printer's electronic circuitry.

The Illustrated Parts List includes all piece parts that can be purchased separately from Apple for the LaserWriter II.



)

)

)



LaserWriter II

Section 1 – Basics

□ CONTENTS

1.3	Product Description
1.3	LaserWriter II SC
1.3	LaserWriter II NT
1.3	LaserWriter II NTX
1.3	LaserWriter II NTX-J
1.4	LaserWriter IIf
1.4	LaserWriter IIg
1.4	Additional Documentation
1.5	Parts of the Printer
1.8	Print Engine Specifications
1.8	General
1.8	Electrical
1.8	Environmental
1.9	Physical
1.9	Performance
1.9	Paper
1.10	Cassette-Feed
1.10	Manual-Feed
1.11	Controller-I/O Board Specifications
1.11	General
1.12	Fonts
1.13	Printable Area
1.14	Theory of Operation—Print Engine
1.15	Main Motor
1.16	Control System
1.18	Laser/Scanner Assembly
1.20	Image Formation System
1.26	Pickup/Feed System
1.29	Power Distribution System
1.30	Theory of Operation—SC Controller-I/O Board
1.30	Introduction
1.30	Overview

- 1.33 Theory of Operation—NT/NTX/NTX-J
Controller-I/O Boards
 - 1.33 Introduction
 - 1.33 Overview
 - 1.35 NT Controller-I/O Board
 - 1.37 NTX/NTX-J Controller-I/O Boards
- 1.41 Theory of Operation—IIf/g
Controller-I/O Boards
 - 1.41 Introduction
 - 1.41 Overview
 - 1.47 Status LEDs
 - 1.48 Toner Cartridge
 - 1.49 Protective Shield
 - 1.49 Light-Blocking Shutters
 - 1.49 Storage
 - 1.50 Handling Procedure
 - 1.51 Setup and Operation
 - 1.52 Test Pages
 - 1.52 Engine Self-Test Page
 - 1.53 SC Startup Test Page
 - 1.53 NT/NTX Startup Test Page
 - 1.55 IIf/g Startup Test Page
 - 1.57 Electrostatic Discharge (ESD) Precautions
 - 1.57 Why Prevent ESD?
 - 1.57 ESD Rules

□ PRODUCT DESCRIPTION

The LaserWriter® II family of printers offers a broad range of printing capabilities. Each member of the LaserWriter II family is capable of producing a full page of text and graphics at 300 dots per inch. Also common to the family is a second-generation print engine, which offers:

- improved print quality
- higher reliability
- enhanced paper-handling capabilities

Each member of the LaserWriter II family consists of a controller-input/output (I/O) board and a second-generation print engine. The print engine is common to all members of the family, and the controller-I/O board is interchangeable. Customers who purchase an entry-level LaserWriter II can later upgrade to a more powerful printer as their needs change.

LaserWriter II SC

The LaserWriter II SC is a single-user, QuickDraw™ printer that connects to the Macintosh® through a SCSI port.

LaserWriter II NT

The LaserWriter II NT is a networkable, PostScript® printer that connects to the Macintosh via AppleTalk® for sharing among several users.

LaserWriter II NTX

The LaserWriter II NTX is a high-performance, expandable, network printer that features a built-in PostScript interpreter and a 16.67 MHz 68020 microprocessor.

LaserWriter II NTX-J

Based on the LaserWriter II NTX, the LaserWriter II NTX-J is a high-performance, expandable, network printer with built-in support for Kanji PostScript. The LaserWriter II NTX-J is configured with 4 MB of RAM and a separate HD40SC hard drive that contains preformatted Kanji printer outline fonts.

Note: To perform repairs or memory upgrades for the LaserWriter II NTX-J, follow the procedures for the LaserWriter II NTX.

LaserWriter IIf

The LaserWriter IIf is the next generation of 300 dpi laser print engine controllers. The IIf provides an upgrade path for LaserWriter II SC, NT, and NTX owners. The LaserWriter IIf offers an anti-aliasing (FinePrint™) feature for improved print quality of text and lines, a 20 MHz 68030 microprocessor for increased throughput, and built-in support for PostScript Level 1 and 2.

This networkable printer supports RS-232 and RS-422 (LocalTalk™) serial connections. The port arbitration capabilities of the IIf printer enable it to process jobs from both ports concurrently. The LaserWriter IIf also provides a SCSI connector that enables the user to attach a local disk drive.

Note: The LaserWriter IIf is capable of enhanced grayscale imaging when the RAM is upgraded to 5 MB or more.

LaserWriter IIg

The LaserWriter IIg, which is based on a 25 MHz 68030 microprocessor, provides all the functionality of the LaserWriter IIf, plus offers superior grayscale imaging through its PhotoGrade™ feature. Grayscale imaging enhancements enable the 300 dpi LaserWriter IIg to produce near-photographic-quality images.

The LaserWriter IIg also features an additional port for connecting to Ethernet® networks. The port arbitration capabilities of the IIg printer enable it to process jobs from serial, LocalTalk, and Ethernet ports concurrently.

Additional Documentation

Following is a list of documents that contain additional information on the LaserWriter II printers:

LaserWriter IISC Owner's Guide

LaserWriter IINT/NTX Owner's Guide

LaserWriter IIf and IIg Owner's Guide

LaserWriter Reference (available from Addison-Wesley Publishing Co.)

Parts of the Printer

Figures 1-1, 1-2, and 1-3 point out the major assemblies and components of the LaserWriter II printer. It will be helpful to refer to these diagrams while you read the Theory of Operation.

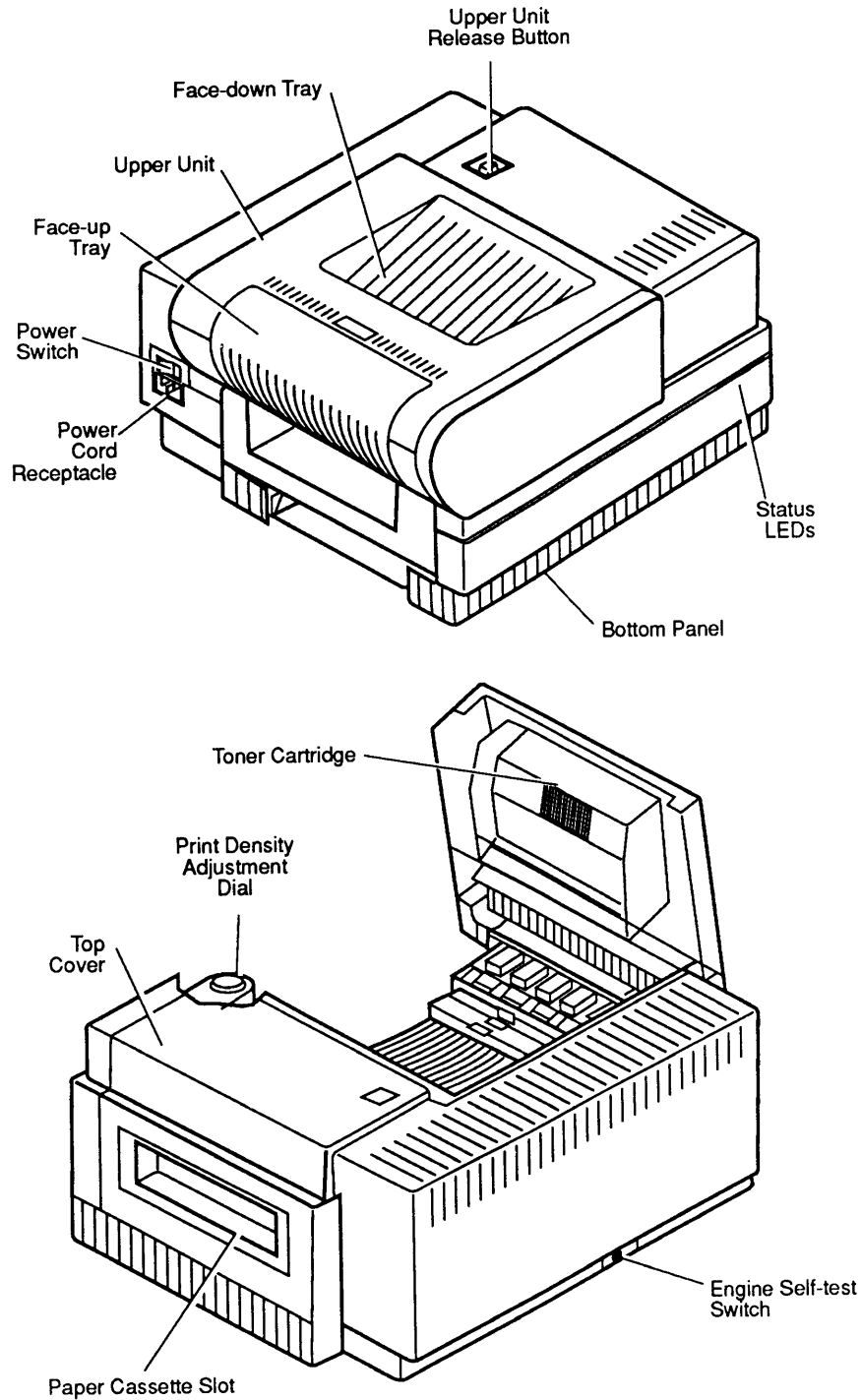

Figure 1-1 Parts of the Printer

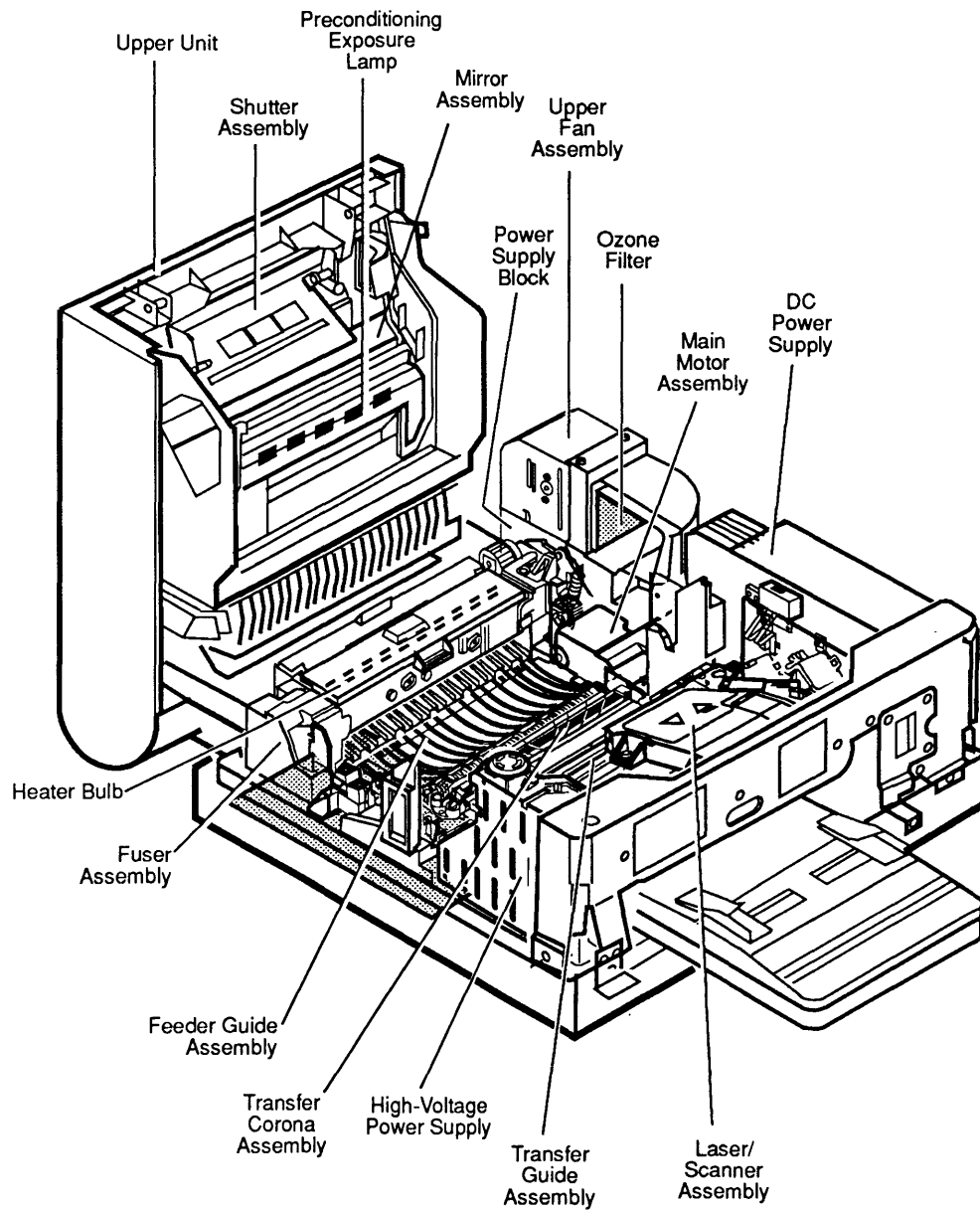
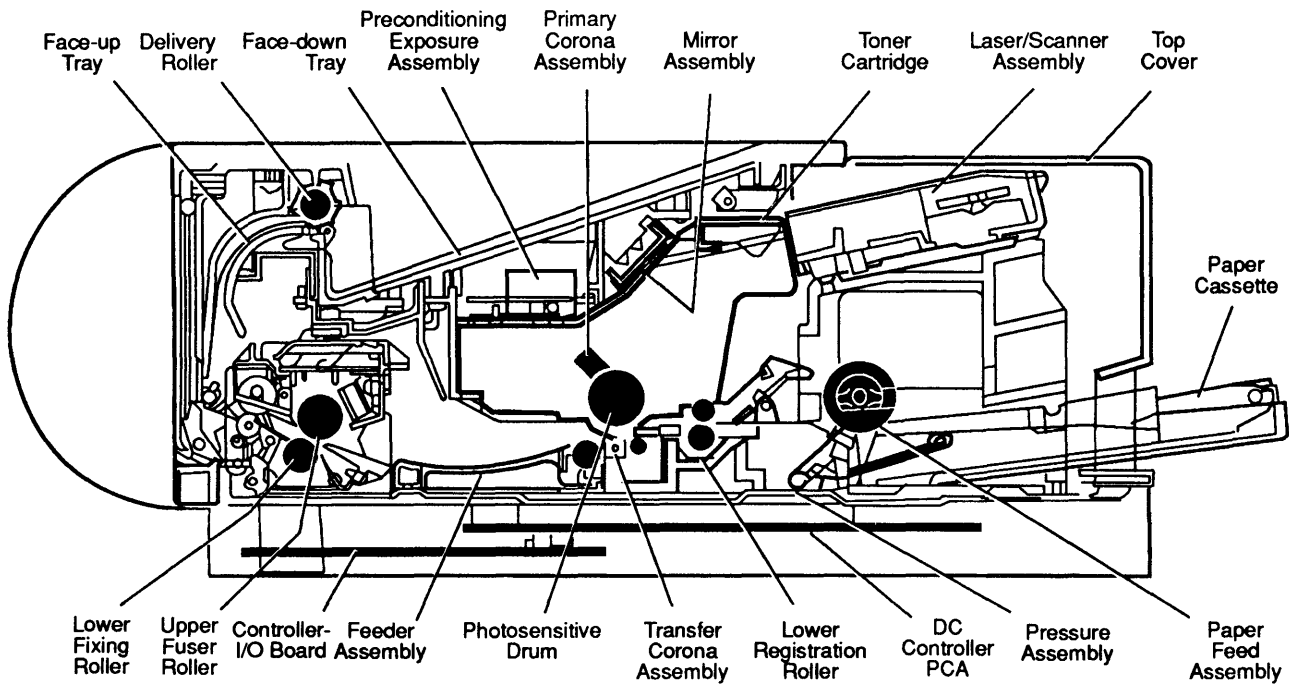

Figure 1-2 Major Assemblies

Figure 1-3 Cross-Section of the Printer



□ PRINT ENGINE SPECIFICATIONS

Following are the print engine specifications for the LaserWriter II SC, NT, NTX, NTX-J, f, and g.

General	Printing method	Electrophotography using single-component dry toner
	Optical system	Semiconductor laser and a rotating 6-faced prism scanning mirror
	Printing Resolution	300 dots per inch (dpi)
Electrical	Line voltage	
	US/Japan	100-115 volts, 50-60 Hz
	Europe/Australia	220-240 volts, 50 Hz
	Power consumption	
	Standby	170 watts (average)
	Operating	900 watts maximum (115 V)
		780 watts maximum (220 V)
		880 watts maximum (240 V)
Environmental	Temperature range	
	Operating	
	<i>Acceptable</i>	50° to 90.5°F (10° to 33°C)
	<i>Recommended</i>	64° to 77°F (18° to 25°C)
	Storage	38° to 95°F (3° to 35°C)
	Humidity range	
	Operating	
	<i>Acceptable</i>	20%-80% relative humidity
	<i>Recommended</i>	30%-70% relative humidity
	Storage	10%-80% relative humidity
Noise Level		
Printing	Under 60 dB(A)	
Standby	Under 50 dB(A)	

Physical

Weight	46 lbs. (21 kg)
Dimensions	
Width	20 in. (51 cm)
Depth	18.9 in. (48 cm)
Height	8.5 in. (21.6 cm)

Performance

Printing Speed	
All paper sizes except legal size	8 pages per minute*
Legal size	7 pages per minute*

* Actual performance depends on the application.

Duty cycle (month)	No limit
Minimum life expectancy	300,000 pages
Major service interval	100,000 copies

Paper

Recommended weights of paper	
Cassette feed	16-24 lb., single-sheet, photocopy bond
Manual feed	16-36 lb., letterhead and colored stock, standard- weight transparency material, envelopes, and labels

Store paper in its package in a dry location. Do not open a package of paper until you are ready to use it.

Cassette-Feed

Cassette sizes	US letter, legal, A4, B5, and envelope cassettes are available as options.
Cassette capacity	
Auto	200 sheets
Manual	Single sheets
Envelope	15 envelopes
Output tray capacity	
Face-down tray	100 sheets
Face-up tray	20 sheets

Manual-Feed

Use manual feed for letterhead, colored stock, standard-weight transparency material, and labels. Envelopes can be manually fed, or an optional envelope cassette is available.

□ CONTROLLER-I/O BOARD SPECIFICATIONS

General

Following are the general controller-I/O board specifications for all LaserWriter II printers.

	SC	NT	NTX/NTX-J	f	g
CPU	68000 (7.45 MHz)	68000 (11.16 MHz)	68020 (16.67 MHz)	68030 (20.0 MHz)	68030 (25.0 MHz)
DRAM	1 MB	2 MB	NTX: 2 MB; Expandable to 12 MB NTX-J: 4 MB; Expandable to 12 MB	4 MB; Expandable to 32 MB	8 MB; Expandable to 32 MB
ROM	16 KB	1 MB	1 MB standard; Up to 8 MB on expansion board	2 MB standard; ROM expansion slot provided	2 MB standard; ROM expansion slot provided
I/O	SCSI Apple Desk- top Bus	LocalTalk RS-232/422	LocalTalk RS-232/422, SCSI	LocalTalk RS-232/422 SCSI	LocalTalk RS-232/422 SCSI Ethernet
Printer Imaging Languages	QuickDraw	PostScript and a subset of the Diablo 630 printer	PostScript, a subset of the Diablo 630 printer, and a subset of the HP LaserJet Plus NTX-J does not support emula- tion mode.	PostScript Level 1 and 2 and HP LaserJet IIP (HP PCL4)	PostScript Level 1 and 2 and HP LaserJet IIP (HP PCL4)

Fonts

The following table lists the fonts available with each LaserWriter II printer model. The table indicates the fonts stored in the printer's ROM (built-in fonts) and those provided on disk (downloadable fonts).

Printer	Built-in Fonts	Downloadable Fonts
II SC	Times [®] , Helvetica [®] , Courier, and Symbol	
II NT, NTX, and NTX-J	Times, Courier, Symbol, Palatino [®] , Helvetica, Helvetica Narrow, ITC Bookman [®] , ITC Avant Garde [®] , ITC Zapf Chancery, ITC Zapf Dingbats [®] , and New Century Schoolbook Built-in fonts can be expanded using an optional font expansion board.	
II f/g	Times, Courier, Symbol, Palatino, Helvetica, Helvetica Narrow, ITC Bookman, ITC Avant Garde, ITC Zapf Chancery, New Century Schoolbook, and Emulator	Chicago, Geneva, Monaco, New York, Palatino, Helvetica Narrow, ITC Bookman, ITC Avant Garde, ITC Zapf Chancery, ITC Zapf Dingbats, and New Century Schoolbook

Note: All LaserWriter II printers support TrueType[™] when using LaserWriter driver 6.1 or greater.

Printable Area

The following table indicates the maximum printable area (in inches) that each LaserWriter II printer model supports.

	SC	NT/NTX/NTX-J	II^f	II^g
US Letter	8.00 x 10.60 in.	8.00 x 10.78 in.	8.11 x 10.79 in.	8.11 x 10.79 in.
A4	8.00 x 11.27 in.	7.79 x 11.08 in.	7.89 x 11.44 in.	7.89 x 11.44 in.
B5	6.67 x 9.43 in.	6.45 x 9.76 in.	6.72 x 9.81 in.	6.72 x 9.81 in.
Legal	6.72 x 12.50 in.	8.00 x 13.78 in.	8.00 x 10.78 in.*	8.11 x 13.79 in.**
#10 Envelopes	3.84 x 9.10 in.	3.84 x 9.10 in.	3.84 x 9.10 in.	3.84 x 9.10 in.

* Maximum printable area with 2 MB of RAM. Prints up to 8.00 x 13.78 in. with 5 MB or more of RAM. Prints up to 8.00 x 13.78 in. using the PhotoGrade feature with 8 MB or more of RAM.

** Prints legal-size documents using the PhotoGrade feature with 8 MB or more of RAM.

□ THEORY OF OPERATION—PRINT ENGINE

The LaserWriter II printer has two basic functional areas—the print engine and the controller-I/O board. This section describes the operation of the print engine, which is the same for all LaserWriter II models.

The print engine includes the following components: the main motor; the four systems with which the motor interacts (**Figure 1-4**); and the power distribution system, which provides the required AC and DC power.

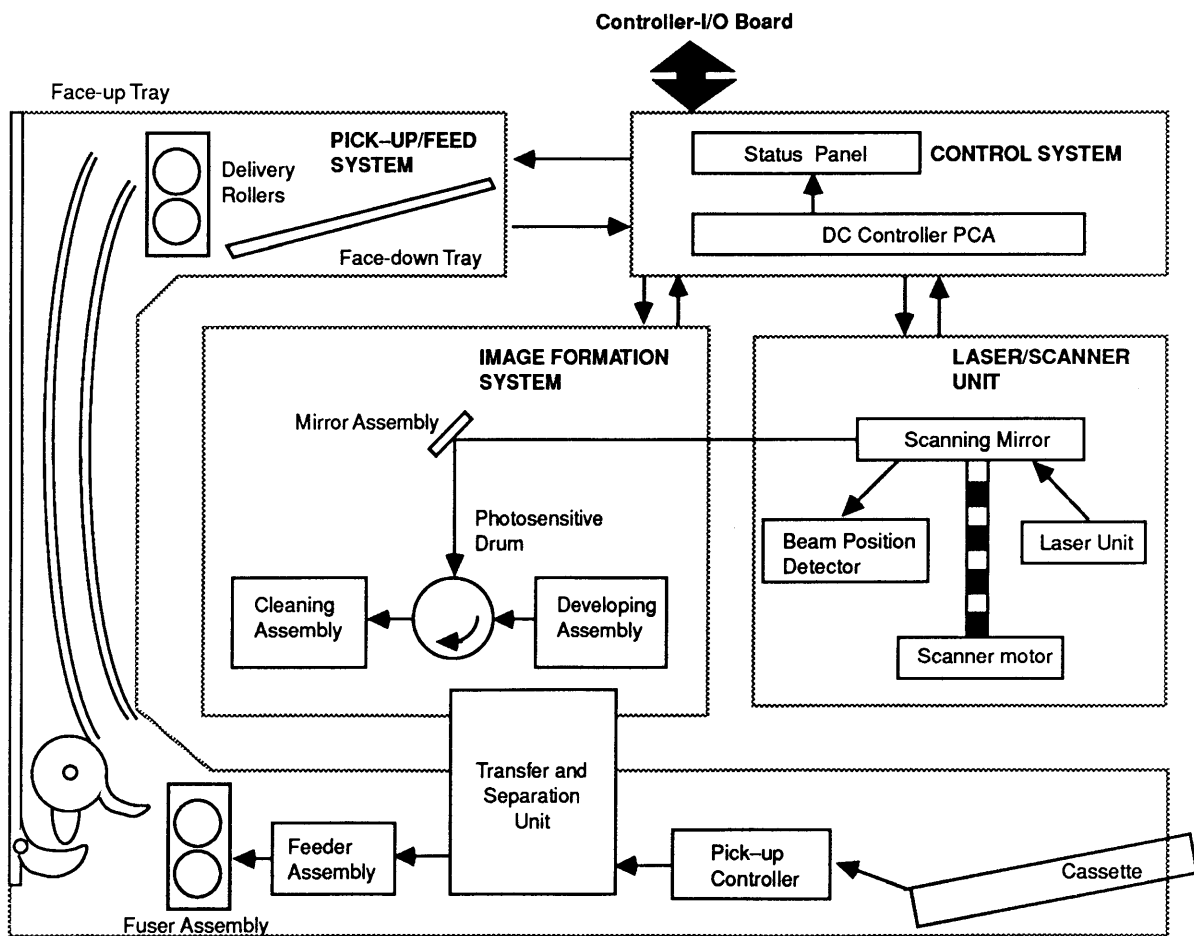

Figure 1-4 LaserWriter II Print Engine

Main Motor

The main motor (**Figure 1-5**) provides the mechanical power the print engine needs. The motor is controlled via a driver circuit in the DC power supply and responds to commands from the DC controller.

The paper feed assembly, registration rollers, toner cartridge, feed rollers, fuser assembly, and delivery rollers all receive mechanical power from the main motor.

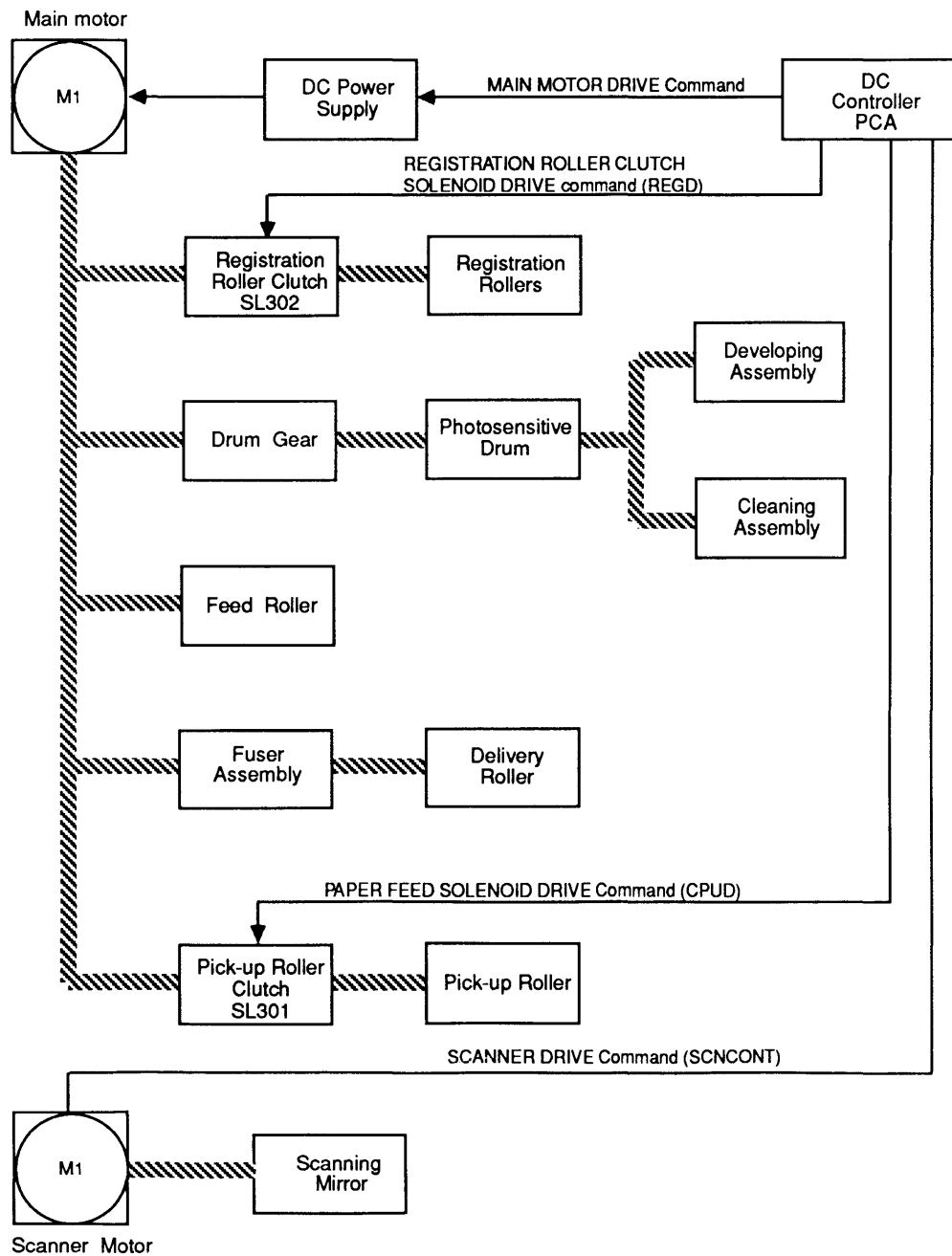

Figure 1-5 Main Motor

Control System

The heart of the print engine is the DC controller PCA (printed circuit assembly), which contains a main CPU and a sub CPU. The DC controller PCA exchanges signals with all the other systems in the printer and the controller-I/O board. The DC controller also generates the control signals for the printer's various functions, thus controlling the actual print cycle (Figure 1-6).

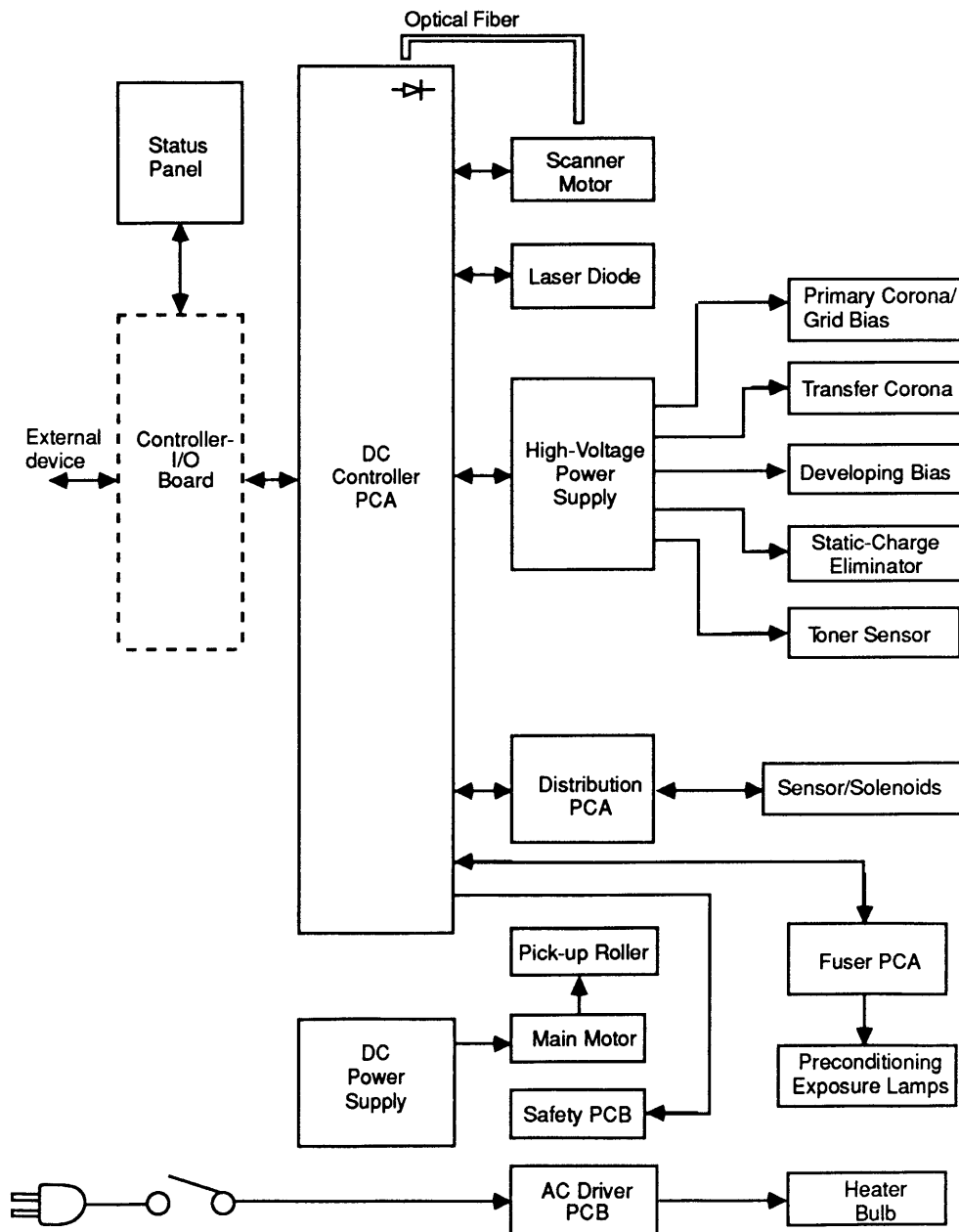

Figure 1-6 DC Controller PCA

One of the functions of the DC controller PCA is to act as an interface between the controller-I/O board and the print engine. When the controller-I/O board receives a print command from the host computer, it sends a print command to the DC controller PCA. The DC controller then generates the signals that:

- Start the main motor, which turns the photosensitive drum and the developing cylinder
- Activate the laser and the scanner motor
- Activate the paper pick-up and feed system
- Activate the high-voltage power supply used for the corona and heating elements in the image formation system

Once the printing process begins, the DC controller monitors the status of the drum sensitivity, the paper feed system, and the laser beam scan position. At the end of the printing, the DC controller monitors whether the print is finished or more information is coming from the controller-I/O board.

The DC controller PCA handles two types of commands—Status Request commands and Executable commands. A Status Request command asks the printer to send information about its status. An Executable command tells the printer to perform an action.

Remember that the DC controller PCA is involved with all the other systems, which are described on the following pages.

Laser/Scanner Assembly

The laser/scanner assembly, which generates the laser beam, consists of the laser unit, the scanning mirror, the scanning motor, and the focusing lenses (**Figure 1-7**).

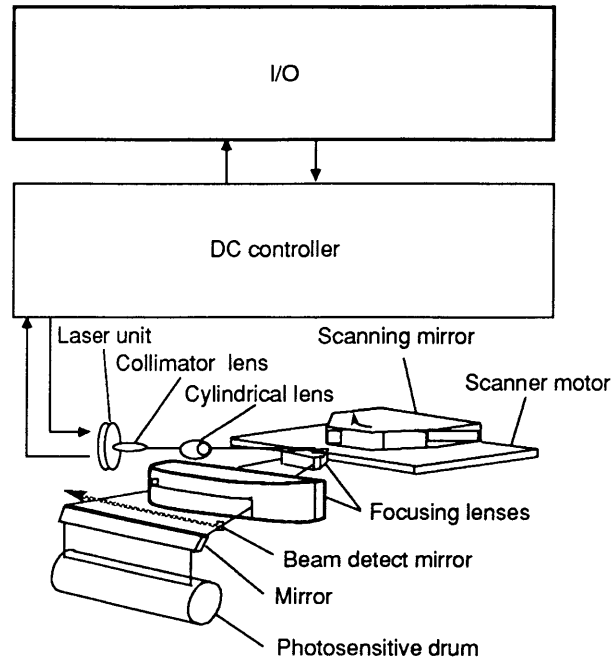

Figure 1-7 Laser/Scanner Assembly

When the DC controller PCA receives a video signal from the controller-I/O board, the PCA sends a Laser Drive (LDRV) command to the laser unit. The laser diode drive level is matched to the sensitivity of the photosensitive drum in the toner cartridge. The laser beam is modulated to form the desired image on the drum.

The modulated laser beam passes through the collimator and cylindrical lenses to form the image. The beam then strikes a six-faced scanning mirror (prism), which rotates at a constant speed. Each face of the mirror reflects the beam, which passes through focusing lenses before striking the mirror in the mirror assembly. The beam then contacts the photosensitive drum.

The photosensitive drum rotates at a constant speed that matches the speed of the scanning beam. That is, in the time it takes for the beam to return to its original position, the drum surface shifts downward to accept the next line.

When the laser beam returns to the start of a scanning line, slightly to the side of the photosensitive drum, its light reflects via the beam detect mirror to the optical fiber. The optical fiber carries the light signal to the DC controller (J201), which senses that the beam is about to scan a new line. As each successive beam scans the drum surface, an image builds on the drum surface in the form of tiny dots that match the transmitted image.

A key part of the scanner is the scanning mirror, which is a hexagonal prism with reflective faces. The mirror is mounted on the scanner motor. The scanner drive circuit controls the motor speed and the DC controller monitors the motor speed. When the scanning motor rotates at the correct speed, LED 201 on the DC controller lights up. After it receives the drive signal from the DC controller PCA, the scanner driver activates the motor.

Image Formation System

The image formation system forms the image on the photosensitive drum and transfers the image to paper. The image formation system includes the toner cartridge, the transfer corona assembly, and the fuser assembly.

The image formation system uses parts of other systems as well. The laser beam from the laser/scanner unit creates the charges that form the image while the pickup/feed system sends the paper to receive the image (Figure 1-8).

The toner cartridge contains the photosensitive drum, developing assembly, and drum-cleaning assembly.

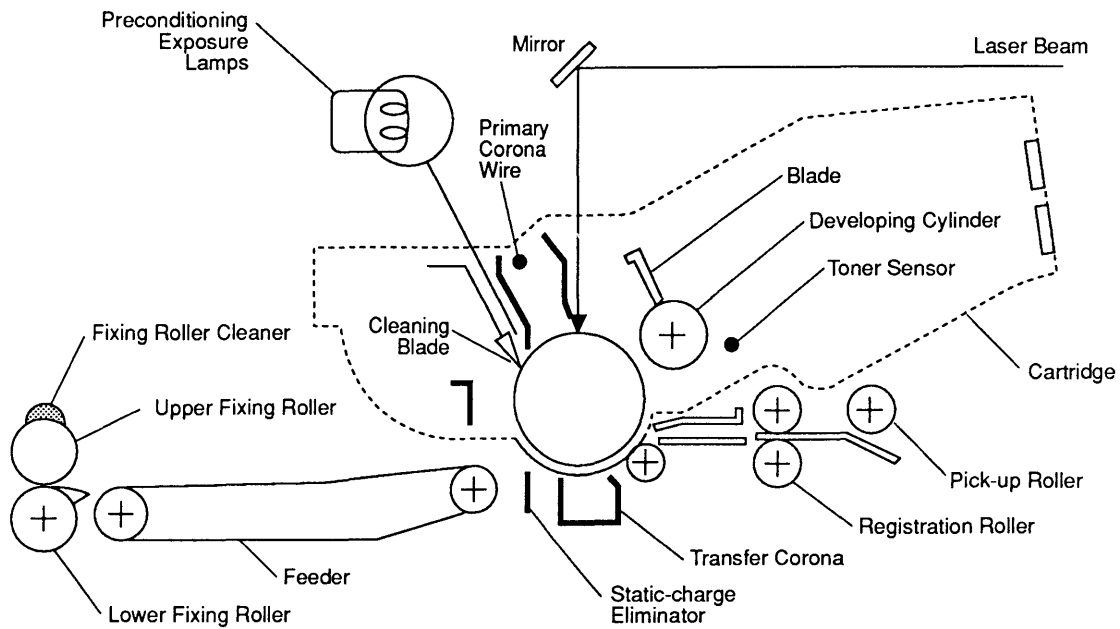

Figure 1-8 Image Formation System

Operation Overview

When the DC controller receives a Print command from the external device via the controller-I/O board, the DC controller activates the main motor to rotate the photosensitive drum and developing cylinder.

After the drum surface receives a negative charge by the primary corona, the laser beam (modulated by the VDO* signal from the DC controller) scans the drum to form a latent image. Toner from the developing cylinder develops the latent image; the image then transfers to the paper because of the charge from the transfer corona.

The cleaning blade removes any remaining toner from the drum, and then the preconditioning exposure lamps illuminate the drum to give it a uniform sensitivity in preparation for forming a new latent image. Identification plugs on the toner cartridge control drum sensitivity. Switches SW301 and SW302 on the distribution PCA sense the presence or absence of the identification plugs. These switches send the CSENS1* and CSENS2* signals to the DC controller and, in turn, the DC controller adjusts the laser beam intensity to match the drum sensitivity.

The cartridge also has a toner sensor. The DC controller monitors the output of this sensor via contacts on the high-voltage power supply connector. When the output falls below a certain level, the printer is almost out of toner and you should replace the cartridge.

The actual printing process has five stages and eight steps, as shown in the following diagram (**Figure 1-9**).

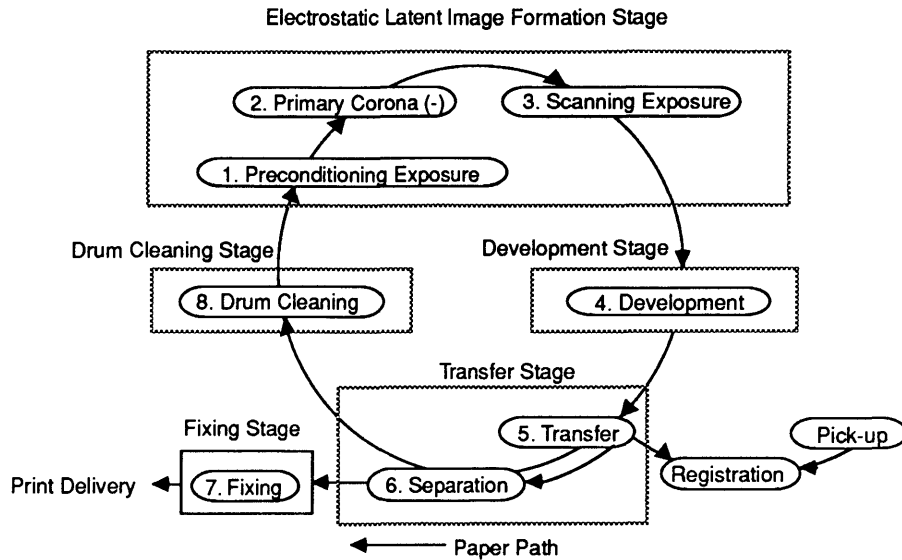

Figure 1-9 Printing Process Diagram

**Stage One:
Electrostatic Latent
Image Formation**

Stage one is the **electrostatic latent image formation stage**. This stage produces a pattern of electrical charges on the drum; the pattern reflects the image to be printed. The formation stage has three steps:

1. Preconditioning exposure: This step exposes the drum to the preconditioning lamp and prepares the drum to receive a uniform charge.
2. Primary Corona: The primary corona (a wire grid) applies a uniform layer of negative charges on the drum surface.
3. Scanning Exposure: In this step, the laser beam scans the drum surface. In the area where the beam strikes the drum, the charge is neutralized. The remaining charges form an invisible pattern called the *electrostatic latent image*.

**Stage Two:
Development**

In the one-step **development stage**, the electrostatic latent image on the drum surface develops into a visible image of toner particles.

The development assembly consists of a development cylinder rotating around a fixed internal magnet and a blade. The cylinder attracts the toner because of the magnet, while the blade skims the toner particles on the cylinder into a thin, uniform layer.

The areas on the photosensitive drum that the laser beam touches have a higher potential than the negatively charged toner on the development cylinder. This difference of potential causes the toner particles to jump from the cylinder to areas of the drum surface exposed to the beam. This process converts the electrostatic latent image into a visible toner image. (This process is called *toner projection development*.) The print density adjustment dial controls the difference in potential between the drum and the cylinder and allows you to adjust for lighter or darker images.

**Stage Three:
Transfer**

The third stage of the image-processing system is the **transfer stage (Figure 1-10)**. In this two-step stage, the toner image on the drum surface transfers to the paper.

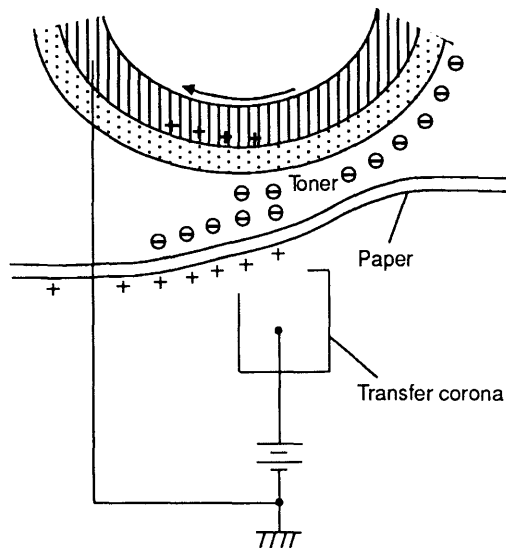

Figure 1-10 Transfer Stage

1. As the paper passes between the drum and the transfer corona assembly, a positive charge moves to the back of the paper. The charge attracts the negatively charged toner particles to the paper.
2. The stiffness of the paper, with an assist from a negative voltage produced by a static-charge eliminator, separates the paper from the drum. The eliminator weakens the attractive force between the paper and the drum (**Figure 1-11**).

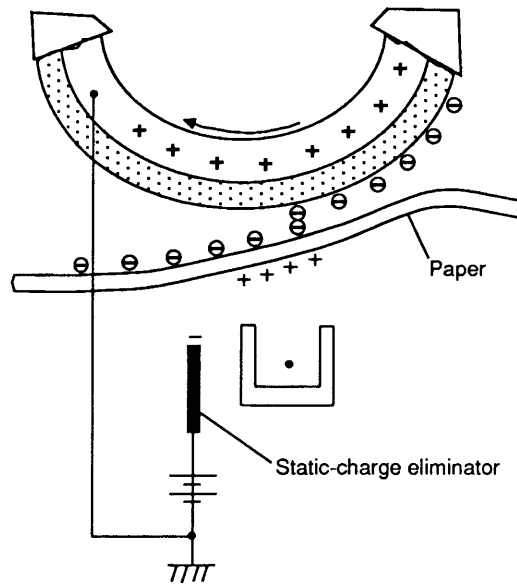

Figure 1-11 Static Charge Eliminator

**Stage Four:
Fusing**

The one-step **fusing stage** permanently fuses the transferred toner to the paper (**Figure 1-12**).

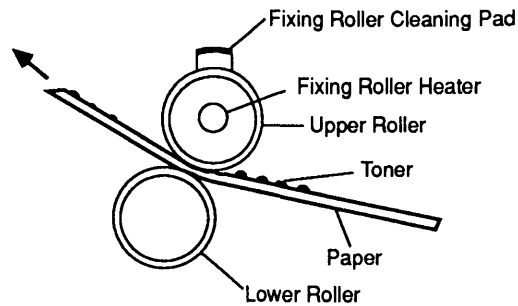

Figure 1-12 Fusing Stage

After the toner image transfers onto the paper, electrostatic attraction and a slight physical adhesion hold the image; even a light touch will smear the image at this point. By heating the paper and applying pressure, the fuser assembly fuses the toner particles onto the paper to make a permanent image.

A nonsticking PTFE resin coats the surface of the upper roller of the fuser assembly, and the cleaning pad applies a further coating of silicone oil. The resin surface and oil keep the paper from sticking to the roller and prevent offsetting (adhesion of toner from one print to the roller and subsequent transfer of toner to another print).

Stage Five:
Drum Cleaning

Drum cleaning is the last image-processing stage. This stage cleans residual toner from the photosensitive drum so that the next print image will be distinct (**Figure 1-13**).

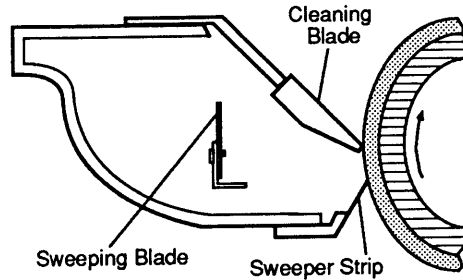

Figure 1-13 Drum Cleaning

In the transfer stage, not all the toner transfers to the paper; some remains on the photosensitive drum. The cleaning blade removes the toner remaining on the drum surface. The sweeping strip collects scraped-off toner, and the sweeping blade pushes the toner away from the drum.

Pickup/Feed System

The pickup/feed system controls the flow of the paper from the cassette to the delivery tray.

Cassette Feed

About 2.2 seconds after the main motor starts, at the beginning of a print cycle, a PICKUP ROLLER CLUTCH SOLENOID DRIVE (CPUD) command arrives at the distribution PCA. Solenoid SL301 actuates and causes the clutch to engage and turn the paper pickup roller, which feeds a sheet of paper to the registration rollers (**Figure 1-14**).

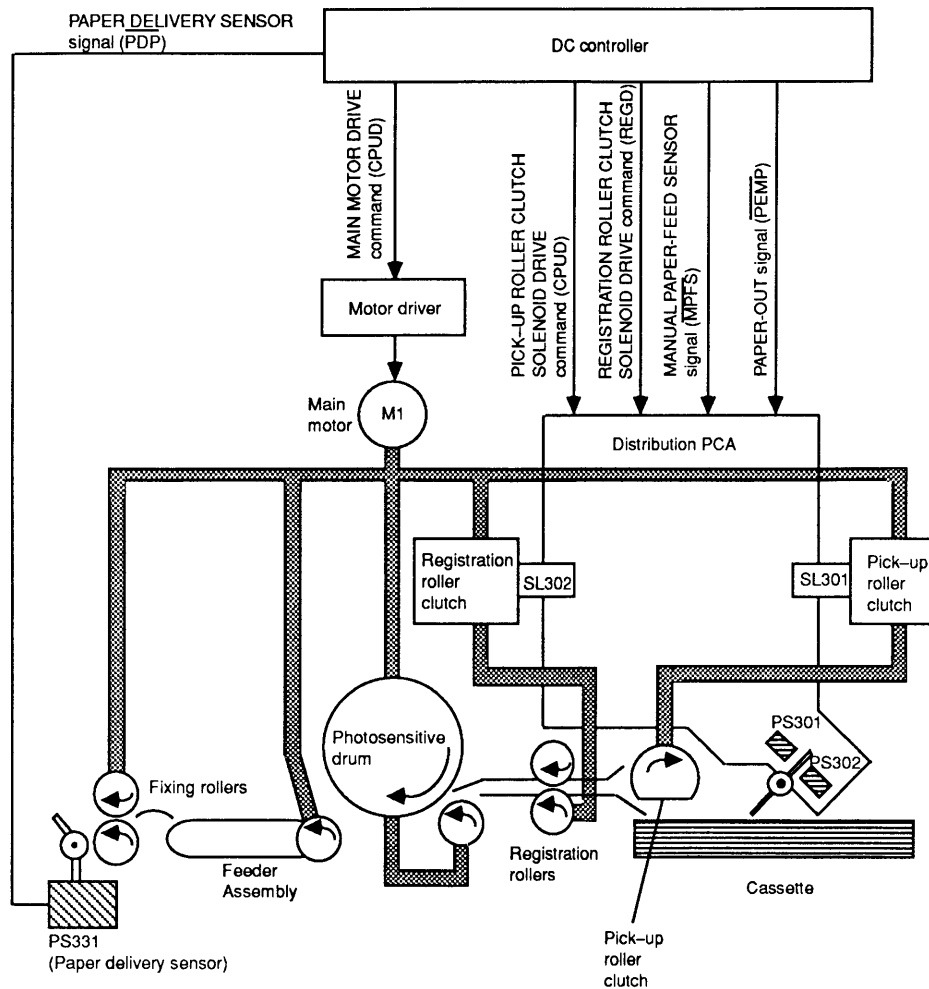

Figure 1-14 Paper Feed Process

The registration rollers are not turning when the paper reaches them, so the paper arches and aligns *along* the rollers. About 2.9 seconds after the PRNT signal, the registration roller clutch solenoid (SL302) actuates, the registration rollers rotate, and the paper feeds toward the photosensitive drum. The action synchronizes so that the leading edge of the paper aligns with the leading edge of the image on the photosensitive drum. After transfer, separation, and fusing, the printed paper arrives in the print tray.

The paper delivery sensor (PS331) on the fuser PCA senses delivery of the paper. If the paper fails to reach and clear the delivery sensor within the specified time, the printer sends a status signal to the external device to notify the user of a paper jam and illuminates the Paper Jam LED on the status panel.

Manual Feed

The timing of manual paper feed is identical to the timing for cassette paper feed except for the following points:

1. Manual feed paper sensor PS302 on the distribution PCA senses that paper is manually feeding on top of the cassette.
2. With cassette paper feed, it takes about 2.2 seconds for the pick-up rollers to start. With manual paper feed, it takes about 6.2 seconds. The delay with manual paper feed allows time for the fuser roller to reach 180°C, which permits the use of heavier paper than with cassette paper feed.

Paper Jam Detection

The paper delivery sensor in the delivery system detects whether paper is feeding normally. The printer microprocessor determines whether paper is jammed by ascertaining whether paper is present or absent at check times stored in memory. If the microprocessor detects a jam, it immediately turns the main motor OFF and illuminates the Paper Jam LED on the status panel.

The paper jam LED illuminates under the following conditions:

- Paper does not reach the delivery sensor within the required time (delivery delay jam).
- Paper does not clear the delivery sensor within the required time (delivery jam).
- Paper is present at the delivery sensor when power is switched ON. (The paper arrives automatically in the print tray if the fixing temperature is 150°C or more.)

Power Distribution System

AC power flows to the DC power supply via the AC driver PCA in the power supply block. The DC power supply generates the +5, -5, and +24 volts DC required by the different systems in the printer.

The DC power supply also generates the printer's reset signal. This signal resets the printer when any of the following conditions are met:

- a) when power is turned on
- b) when VDC falls below a minimum level (+5)
- c) when power supply voltage is momentarily interrupted

Protection Circuitry

Should a short circuit or other fault cause excessive draw from any of the DC power supplies, a protection circuit automatically switches off the output voltage to protect the power supply.

To reset the power supply after the protection circuit triggers, turn off the printer and locate and repair the fault. When the printer is turned on again, the power supplies will operate normally.

A circuit breaker (CB1) protects the power supply and fuser assembly from damage in the event of excess current draw by the heater bulb. The circuit breaker is located on the power supply block below the ozone filter (see Appendix, Photo #1).

REMOTTEON* Signal

The REMOTTEON* signal goes from the DC controller to the DC power supply at power-on. The signal controls the application of the three DC voltages. When power is switched on, the +5 volt supply switches on, followed by the +24 and -5 volt supplies. This control of the power supplies protects the printer from an immediate application of +24 volts.

□ THEORY OF OPERATION—SC CONTROLLER-I/O BOARD

Introduction

The controller-I/O board for the LaserWriter II SC slides into a card slot in the base of the print engine. The controller-I/O board connects to the print engine's control electronics, specifically the DC controller PCA, through a 32-pin right-angle socket connector.

Overview

The SC controller-I/O board (**Figure 1-15**) is an electronic circuit board that provides a Small Computer System Interface (SCSI) between the print engine and host computer. Standard Apple SCSI cables are used to attach the controller-I/O board to the Macintosh.

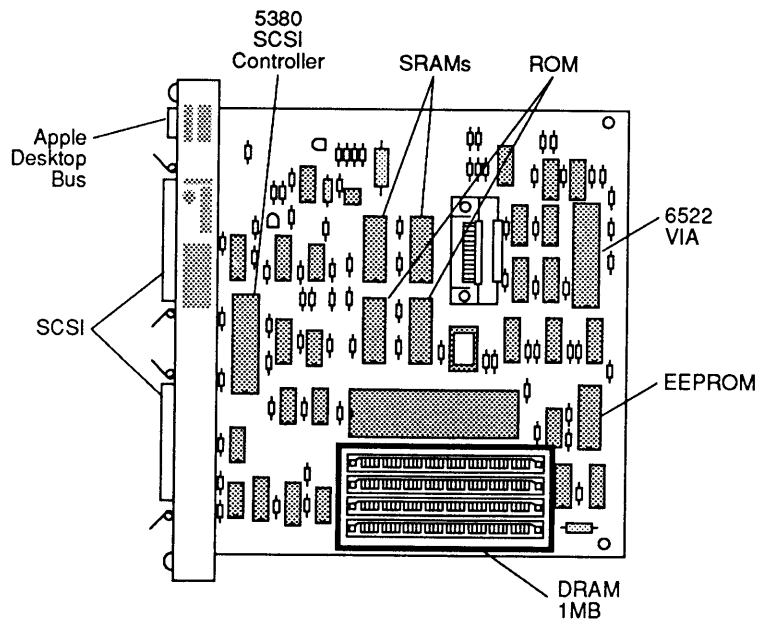

Figure 1-15 SC Controller-I/O Board

The SC controller-I/O board controls the printing process as follows: QuickDraw creates a bit-mapped image of the page in the Macintosh. The Printing Manager uses the SC driver to send portions of the bit-mapped page image over the SCSI bus to the SC RAM. The data stops when the SC controller-I/O board has reconstructed the entire bit-mapped image of the page in RAM. At that point, the print signal goes to the DC controller PCA and the printing cycle starts.

The SC controller-I/O board receives the bit-mapped images over the SCSI bus by means of SCSI commands from the host. The controller-I/O board uses high-speed circuitry to load data blocks of up to 512 bytes each into a First-In, First-Out (FIFO) register.

The controller-I/O board's 68000 CPU takes this data out of the FIFO register and puts it into the frame buffer RAM at the location specified by the SCSI command. The SCSI command also specifies whether the data should be OR'd, XOR'd, COPY'd, or CLEAR'd into the frame buffer, depending on the combination of text and graphics that makes up the page image.

This process continues until the entire bit-mapped image of the page arrives in the frame buffer. When the page image is finished, the 68000 CPU takes the first scan line out of RAM and puts it back into the FIFO register (approximately 300 bytes for each 8-inch scan line). When the controller-I/O board receives notification that the print engine is ready, the video control circuit loads the scan line, one byte at a time, into the shift register and sends the line to the print engine. When the last byte of the scan line arrives at the print engine, the CPU loads the FIFO register with the next scan line.

CPU

The CPU is an MC68000 32-bit microprocessor running at 7 MHz. It provides the necessary processing functions for the SC controller-I/O board.

ROM

16 KB of ROM contains the SCSI control routines, printer diagnostics, error-reporting routines, and laser print engine control routines.

SRAM

A static random-access memory (SRAM) provides for a reconfigurable ROM vector table. The CPU copies the low-memory vector table from ROM into SRAM. This low-memory vector table points to the fixed-print control routines present in ROM.

DRAM

One megabyte of dynamic random-access memory (DRAM) is installed. The DRAM acts as a frame buffer for constructing the bit-mapped page image during the print process.

VIA

The Versatile Interface Adapter (VIA) provides parallel I/O for the handshaking signals, status panel LEDs, miscellaneous functions, and Apple Desktop Bus™ (ADB) interface.

53C80 SCSI Controller

The SC controller-I/O board communicates with the host computer over the SCSI bus. The SCSI IC controls the bus signals and their timing, according to the SCSI ANSI standard. The SCSI IC, in conjunction with the CPU and ROM firmware, implements the SC SCSI command set that drives the print engine.

To achieve peak data transfer rates of up to 558 KB per second, the SC controller-I/O board uses high-speed transfers from the SCSI I/O controller directly to the FIFO register. The high-speed circuit loads the number of bytes to be moved. The circuit then automatically transfers that number of bytes from the SCSI chip to the FIFO register.

□ THEORY OF OPERATION—NT/NTX/NTX-J CONTROLLER-I/O BOARDS

Introduction

The controller-I/O boards for the LaserWriter II NT, NTX, and NTX-J slide into a card slot in the base of the print engine. The boards connect to the print engine's control electronics, specifically the DC controller PCA, through a 32-pin right-angle socket connector.

Overview

The NT, NTX, and NTX-J controller-I/O boards interface between the LaserWriter II print engine and computers over an AppleTalk network using the LocalTalk cabling system or through an RS-232/422 serial interface. Standard LocalTalk or serial interface cables attach the controller-I/O board to the host computer or a LocalTalk network.

The printing manager uses the LaserWriter driver to convert the image on the computer screen into a PostScript file that the NT/NTX/NTX-J controller-I/O board can process. The PostScript file travels from the Macintosh to the LaserWriter over the LocalTalk network. The serial connection can also be used.

The PostScript program data transmits until the LaserWriter PostScript interpreter in the printer ROM has reconstructed an entire page image in the printer RAM. The printer then sends the appropriate data and commands to the DC controller PCA and onto the print engine.

The LaserWriter, LaserWriter Plus, and the LaserWriter II NT/NTX/NTX-J controller-I/O boards interact with the print engine similarly. The controller-I/O board receives Postscript programs in the form of ASCII control data (when in emulation mode) from the host computer over the LocalTalk or RS-232 serial connection.

All of the serial data that the controller-I/O boards receive through the serial port is under the control of the Serial Communications Controller (SCC). When a data byte enters the SCC from a serial port, the SCC generates an interrupt to the controller-I/O board CPU. This interrupt causes the CPU to take the data out of the SCC internal buffer, and to place the data in a larger AppleTalk buffer.

After the program data is in the AppleTalk buffer, the CPU can begin to execute the PostScript program. The CPU then creates the page image in the controller RAM according to the commands in the PostScript program. This process continues until the entire bit-mapped image of the page appears in the frame buffer.

When the page image is constructed, the CPU takes the image data out of RAM and puts it into a first-in, first-out (FIFO) buffer. When the controller-I/O board Versatile Interface Adapter (VIA) receives notification from the DC controller PCA that the printer is ready, the Video Control circuit on the controller-I/O board loads the scan line data, one byte at a time, into the Shift Register and sends the data to the DC controller.

The DC controller receives the data as digital bits in the form of serial signals that correspond to black or white dots of the image. The DC controller then generates the print signals to start and control the printing cycle, as explained in the print engine section.

NT CONTROLLER-I/O BOARD

A block diagram of the NT controller-I/O board (Figure 1-16) follows.

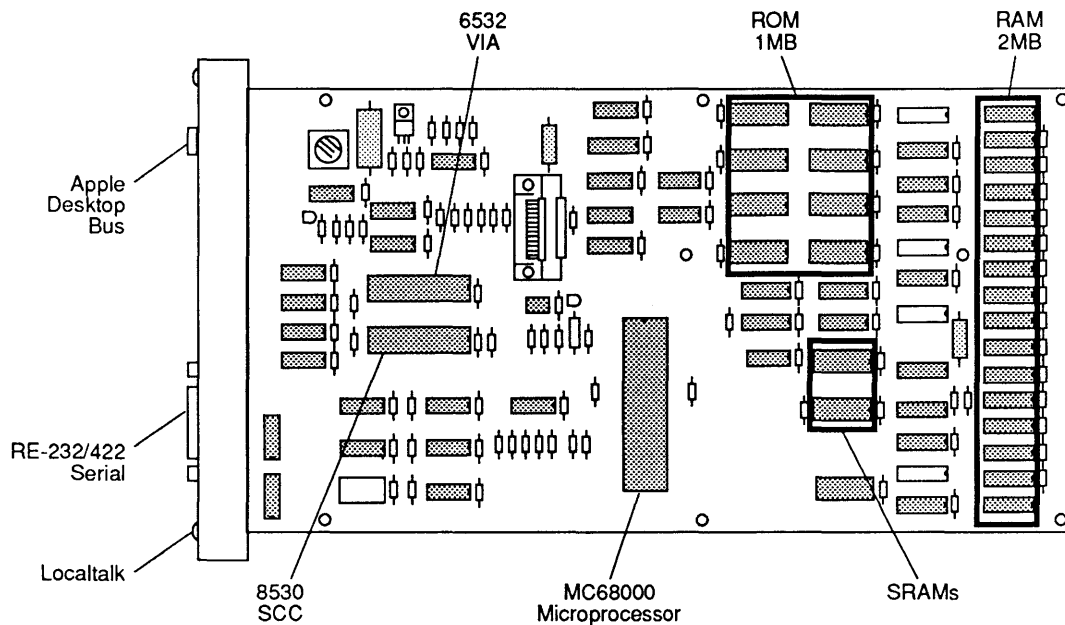

Figure 1-16 NT Controller-I/O Board

CPU

The CPU on the NT is a Motorola MC68000 32-bit microprocessor operating at 11.16 MHz. The CPU provides all the central processing functions for the NT controller-I/O board.

ROM

The NT has 1 MB of ROM. This firmware contains printer-control routines, the Adobe® Systems PostScript interpreter, printer diagnostic routines, printer emulator routines, AppleTalk routines, LaserWriter Plus fonts, and error-reporting routines.

DRAM

The NT controller-I/O board contains 2 MB of DRAM (dynamic random-access memory). This memory functions as an AppleTalk data buffer, a font-cache buffer for caching character bitmaps, a frame buffer for constructing the bitmapped page image, and a display-list buffer for storing compiled PostScript instructions.

SRAM

The controller-I/O board has two static RAMs (SRAMs) that are used for the operating system stack.

FIFO

The CPU loads video data in RAM into the FIFO register on a scan-line-by-scan-line basis. The video control logic then reads the FIFO register and unloads the video data into the shift register. The video control logic also provides the shift clock to the video shift register.

VIA

The 6532 Versatile Interface Adapter (VIA) provides parallel I/O for the handshaking signals between the controller-I/O board and the print engine. The VIA also supports the Apple Desktop Bus interface.

SERIAL I/O SCC

The Serial Communication Controller (SCC) controls all communication with the host over the serial bus. The SCC has two independently programmable channels. Each channel can be programmed for asynchronous, synchronous, or AppleTalk protocols.

The serial interface connects to a host computer through a subminiature DB-25 connector or an 8-pin mini DIN-8 connector.

**NTX/NTX-J
CONTROLLER-I/O
BOARD**

A block diagram of the NTX/NTX-J controller-I/O board (**Figure 1-17**) follows.

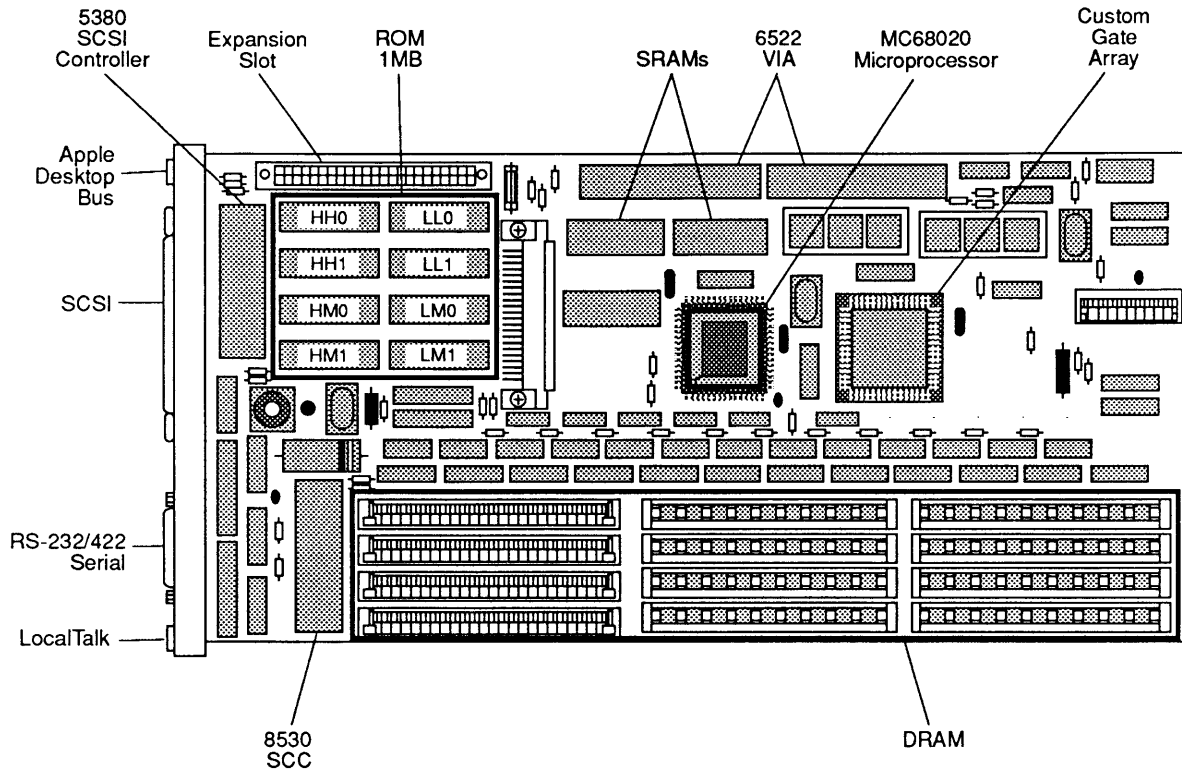

Figure 1-17 NTX/NTX-J Controller-I/O Board

CPU

The CPU is a 16 MHz Motorola MC68020 microprocessor that provides all the central processing functions for the NTX/NTX-J printer. The CPU also supports programs written for the original LaserWriter, LaserWriter Plus, and the LaserWriter II NT model. The CPU is a true 32-bit microprocessor, and it executes much faster than the CPUs in other LaserWriter or LaserWriter II models.

DRAM

The NTX controller-I/O board uses 256 KB and/or 1 MB SIMMs (single in-line memory modules) to support from 2 to 12 MB of dynamic RAM. Memory sizes of 2, 3, 4, 5, 8, 9, and 12 MB are possible. The DRAM is used as an AppleTalk data buffer, a font cache buffer for caching character bit maps, a frame buffer for constructing the bit-mapped page image, and a display-list buffer for storing compiled PostScript instructions.

FIFO

The CPU loads video data in RAM into the FIFO register on a scan-line-by-scan-line basis; the video controller unloads the data into the shift register.

The shift register converts the FIFO register output into a serial bit stream under the control of the video controller. The video controller reads the FIFO register and loads the shift register. The video controller also provides the shift clock to the shift register.

ROM

The NTX controller-I/O board uses 1 MB of ROM. This firmware contains printer-control routines, the Adobe Systems Postscript interpreter, printer diagnostic routines, printer emulator routines, AppleTalk routines, LaserWriter Plus fonts, and fixed-disk support and error-reporting routines.

Note: The NTX-J controller-I/O board does not support emulation mode.

Serial I/O (SCC)

The Serial Communications Controller (SCC) has two independent ports for serial communication. The 25-pin serial port is for non-LocalTalk serial connections. The LocalTalk port is for connecting to any computer in a LocalTalk cable system.

The serial interface connects to a host computer through a subminiature DB-25 RS-232 connector or an 8-pin MINI DIN-8 connector.

SCSI

The Small Computer System Interface (SCSI), together with extensions in NTX/NTX-J ROM for a disk-based file system, provide for connection of a SCSI hard disk. You can use this disk as additional virtual memory for expanding display-list buffers for printing complex pages and as nonvolatile storage for a cache of fonts.

The NTX/NTX-J SCSI interface consists of the NCR 53C80 SCSI controller and an external 50-pin SCSI connector. The SCSI controller connects directly to the 50-pin external connector. The NTX controller-I/O board does not provide termination of the SCSI signals or active power for external terminators. External terminator plugs are required. Another device connected to the SCSI bus (typically a hard disk) must provide power for those terminators.

Video Interface

The NTX/NTX-J controller-I/O board receives digital bits in the form of serial signals that correspond to black or white dots that make up an image. The printer modulates a laser beam to create an image based upon the signals received by the video interface. The controller-I/O board sends printer parameter commands to the DC controller, which returns a status update to the controller-I/O board.

While these signals are being exchanged, the controller-I/O board processes the bit-mapped image. After the image is complete, it transfers from the controller-I/O board RAM to the printer through the video interface. The NTX controller-I/O board sends video data to the DC controller PCA until the page image is complete or until a paper-out, paper jam, or printer error occurs.

VIA1/VIA2 Interface

The NTX/NTX-J Versatile Interface Adapters (VIA1 and VIA2) control a variety of controller processes by monitoring requests between the controller-I/O board and DC controller PCA. VIA1 controls data transmission through the video interface to the print engine and returns a status message (either Ready or Busy) to the controller-I/O board. VIA2 lights the printer status LEDs, monitors the settings of the communication mode configuration switches on the controller-I/O board, and reports the status of the printer power-up self-test.

Note: The controller-I/O board contains an unused ADB port.

ZPRAM

The serial-port configuration setting is stored in the battery-backed Zero-Power RAM (ZPRAM). When the printer is on, you can change the configuration information by sending PostScript control operators to the printer or by changing the mode configuration switch settings.

Whenever the mode configuration switch settings change, the configuration stored in the ZPRAM updates to match the new settings. If the switches change while the printer is powered off, VIA2 updates the ZPRAM configuration at power-on when it reads the switch settings. The configuration information stored in the ZPRAM remains after the power has been switched off and then on.

If you believe the controller-I/O board is incorrectly configured, toggle any switch, wait 30 seconds, and then toggle the switch back to its normal position. This procedure forces the ZPRAM configuration information to match the switches and overrides any conflicting software-downloaded configuration.

Expansion Slot

The NTX/NTX-J controller-I/O board contains a plug-in expansion slot for future use (e.g., for more memory or font storage).

□ THEORY OF OPERATION—IIf/g CONTROLLER-I/O BOARDS

Introduction

The controller-I/O boards for the LaserWriter IIf and IIg printers slide into a card slot in the base of the print engine. The boards connect to the print engine's control electronics, specifically the DC controller PCA, through a 32-pin right-angle socket connector.

Overview

The IIf and IIg controller-I/O boards interface between the LaserWriter II print engine and compatible computers through an RS-232/422 serial or AppleTalk interface using the LocalTalk cabling system. The IIg controller-I/O board also provides an additional port for connecting to Ethernet networks using the Apple Ethernet Cable system. Both the IIf and IIg controller-I/O boards allow for simultaneous communication through all ports.

Before the printing process begins, the computer sends a page description to the printer over the network (i.e., LocalTalk or Ethernet). The printer rasterizes the page description, turning it into a bitmap image that the controller-I/O board can process. The printer then sends the appropriate data and commands to the DC controller PCA and onto the print engine.

The LaserWriter IIf and IIg controller-I/O boards receive Postscript (or HP LaserJet when in emulation mode) page descriptions in the form of ASCII control data from the host computer over the LocalTalk, RS-232 serial, or (in the case of the IIg) Ethernet network.

All of the serial data that the controller-I/O boards receive through the serial port is under the control of the serial communications controller (SCC). When a data byte enters the SCC from a serial port, the SCC generates an interrupt to the peripheral interface controller (PIC). This interrupt causes the PIC to take the data out of the SCC internal buffer and to place the data in an SRAM.

Note: When a complete packet of data arrives, the PIC interrupts the CPU and requests transfer of the packet from the controller-I/O board's SRAM to its DRAM.

As packets of a PostScript page description arrive, the CPU executes the page description until it has created the page image in the controller-I/O board RAM according to the PostScript commands. When the page image is complete, a direct memory access (DMA) process takes the image data out of RAM and sends it to the printer's DC controller.

The DC controller PCA receives the data as digital bits in the form of serial signals that correspond to black or white dots of the image. The DC controller PCA then generates the print signals to start and control the printing cycle, as explained in the print engine section.

CPU

The CPU provides all the central processing functions for the printer. The CPUs in the LaserWriter Iif and Iig printers continue to support programs written for the original LaserWriter, LaserWriter Plus, and NT/NTX/NTX-J printers.

Iif: The CPU in the Iif printer is a 20 MHz Motorola 68030 microprocessor (**Figure 1-18**). The CPU is a true 32-bit microprocessor that enables the Iif to process PostScript jobs up to 1.5 times faster than does the LaserWriter II/NTX.

Iig: The CPU in the Iig printer is a 25 MHz Motorola 68030 microprocessor (**Figure 1-19**). The CPU is a true 32-bit microprocessor that enables the Iig to process PostScript jobs up to 2.0 times faster than the LaserWriter II/NTX.

ROM

The LaserWriter Iif and Iig controller-I/O boards use 2 MB of ROM (installed as four 512K ROM chips). This firmware contains: printer-control routines; the Adobe Systems Postscript Level 2 interpreter; printer diagnostic routines; PCL 4 printer emulator routines; AppleTalk routines; fonts; PhotoGrade and FinePrint capabilities; and fixed-disk support and error-reporting routines.

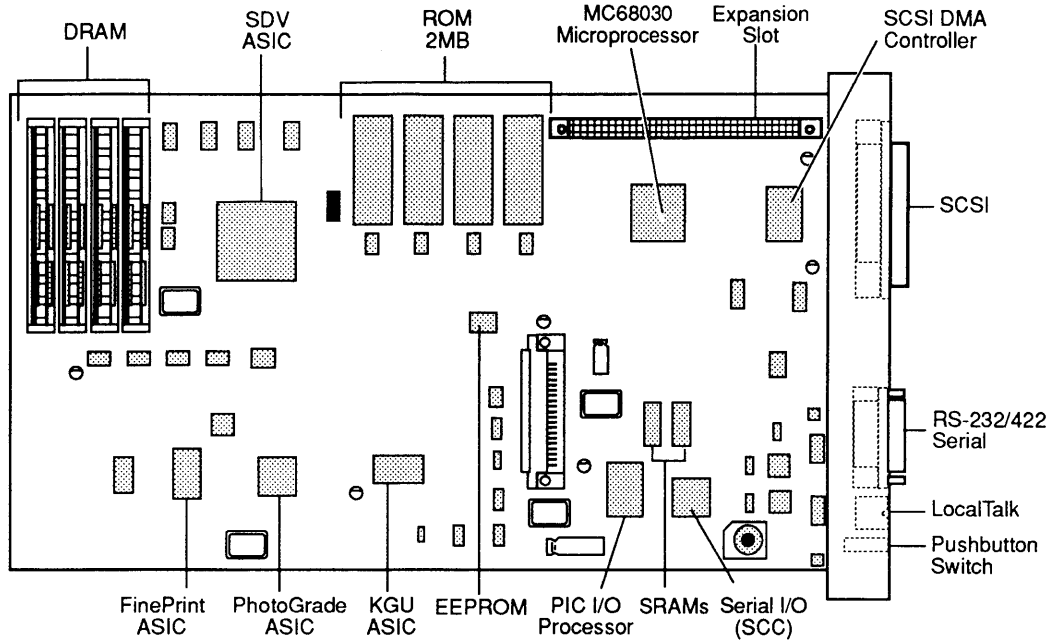

Figure 1-18 IIf Controller-I/O Board

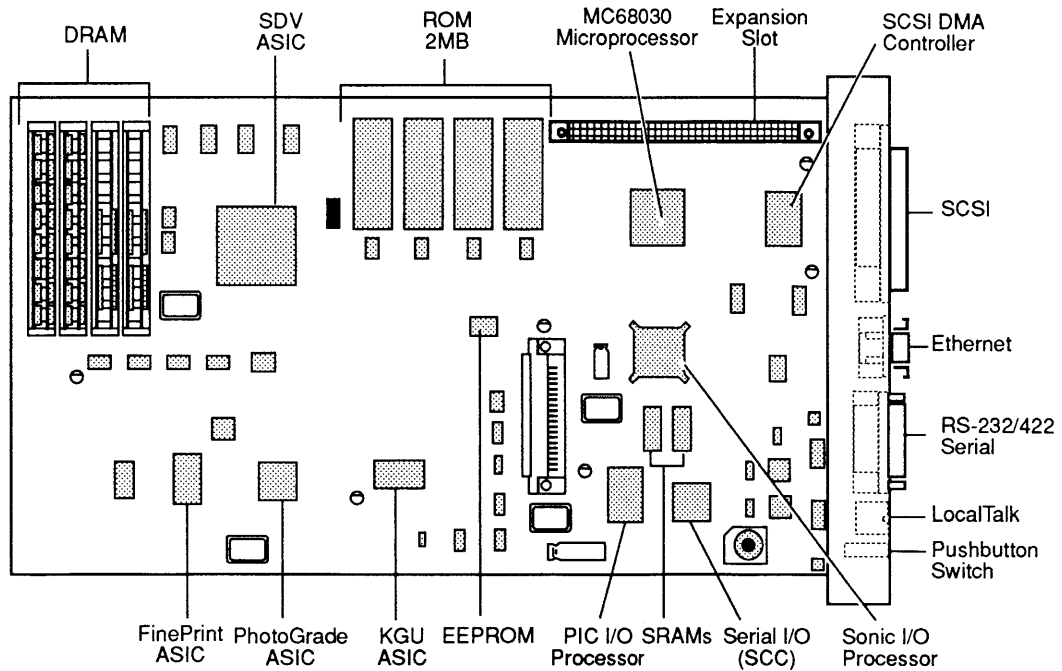



Figure 1-19 IIG Controller-I/O Board

DRAM

The controller-I/O boards in the LaserWriter IIf and IIg can use 256K, 1 MB, or (when available) 4 MB SIMMs to support up to 32 MB of dynamic RAM. The minimum memory configuration for the IIf is 4 MB of DRAM; the minimum configuration for the IIg is 8 MB of DRAM.

The DRAM provides an AppleTalk data buffer, a font-cache buffer for caching character bitmaps, a frame buffer for constructing the bitmapped page image, and a display-list buffer for storing compiled PostScript instructions.

Note: The LaserWriter IIf and IIg printers use 30-pin, 80 ns DRAM SIMMs, which are **not** compatible with the RAM in the LaserWriter II SC, NT, NTX, or NTX-J printers. The SIMMs in the IIf and IIg are the same as those in the Macintosh IIfx and IIfx computers.

IMPORTANT: Refer to the  Quick Reference: SIMM Compatibility chart for a comprehensive list of all compatible SIMMs.

Serial I/O (SCC)

The serial communications controller (SCC) has two independent ports for serial communication. The 25-pin RS-232 serial port is for non-LocalTalk serial connections. The DIN-8 RS422 LocalTalk port is for connecting to a LocalTalk cable system.

The serial interface connects to a host computer through a subminiature DB-25 RS-232 connector or an 8-pin MINI DIN-8 connector.

PIC I/O Processor ASIC

The PIC is the interface between the SCC and the 68030 microprocessor. The PIC interrupts the 68030 upon receipt of an entire packet of data instead of the SCC interrupting the CPU after every character. The PIC manages the I/O ports and reduces the need for the main processor to respond to AppleTalk and EtherTalk transmissions, serial connections, and other I/O tasks.

SRAMs

The IIf and IIg printers each have three SRAMs: the PIC uses one SRAM to download its own program; another is for inbound and outbound packets of data; and the FinePrint ASIC uses the remaining SRAM.

SCSI

The small computer system interface (SCSI), together with extensions in the LaserWriter IIf and IIg ROM for a disk-based file system, provide for connection of a SCSI hard disk. You can use this disk as nonvolatile storage for a cache of fonts or files.

The LaserWriter IIf and IIg SCSI consists of a SCSI DMA (direct memory access) ASIC and an external 50-pin SCSI connector. The SCSI DMA ASIC is connected directly to the 50-pin external connector. The IIf and IIg controller-I/O boards provide termination of the SCSI signals, but do not provide termination power.

An external hard disk provides the termination power. This disk must have a "black" SCSI terminator on one of its SCSI connectors. You may add other disks between the printer and the terminated disk.

Because the LaserWriter IIf and IIg use a different disk file system than the NTX printer, you must reinitialize NTX hard disks (using the LaserWriter Utility) before they can be used with the IIf or IIg printers. **As this procedure erases all data on the disk, be sure to back up all printer fonts and other important information before reinitializing the hard disk.**

SCSI DMA I/O ASIC

The SCSI DMA I/O ASIC is based on the NCR 53C80 controller. This ASIC allows access to a SCSI font disk without requiring the attention of the main processor.

Video Interface

The IIf and IIg controller-I/O boards send digital bits in the form of serial signals that represent black or white dots. The printer modulates a laser beam to create an image based upon the signals received by the video interface. The controller-I/O board sends printer-parameter commands to the DC controller and monitors the status information that the DC controller returns.

When the image is complete, it transfers from the controller-I/O board RAM to the printer through the video interface. The controller-I/O board sends video data to the DC controller PCA until the page image is complete or until a paper-out, paper jam, or printer error occurs.

<i>EEROM</i>	The serial-port configuration, printer name, number of pages printed, and many other parameters are stored in the electrically erasable read-only memory (EEROM).
<i>Expansion Slot</i>	The LaserWriter IIf and IIg controller-I/O boards contain a plug-in expansion slot for future use (e.g., for more memory or font storage).
<i>Sonic I/O Processor</i>	The Sonic I/O processor, which is found only in the LaserWriter IIg, supports Ethernet communications.
<i>SDV ASIC</i>	The SDV (single-channel DMA video) ASIC is responsible for transferring the fully imaged page buffer directly from RAM to the SX engine, thereby improving performance by relieving the main processor of this task.
<i>KGU ASIC</i>	The KGU (Kirin glue unit) ASIC reduces the workload of the main processor by coordinating access to ROM, the PIC and SCSI DMA I/O ASICs, LEDs, and other devices.
<i>FinePrint ASIC</i>	The FinePrint anti-aliasing ASIC improves print quality by smoothing jagged text and curves, without requiring time from the main processor. For each line or curve, the FinePrint ASIC calculates the best possible edge to a very high degree of accuracy and then renders the edge for a noticeably smoother printed result.
<i>PhotoGrade ASIC</i>	The PhotoGrade ASIC controls gray imaging, enabling the LaserWriter IIg (or the IIf with 5 MB of RAM or more) to print images of near-photographic quality. The PhotoGrade ASIC gives the LaserWriter IIg more control in the size and pattern of dots printed, allowing for many more shades of gray than previously possible on a 300 dpi printer.

□ STATUS LEADS

The status LEDs on the front panel of the printer (**Figure 1-20**) provide the following information:

1. The green Ready/In-Use light flashes during warmup and when the printer is operating. The light is steady when the printer is warmed up and ready to print. The light is off when the printer is not ready, an error condition exists, or the top cover is open.
2. The orange Low-Toner light is on and steady when the toner cartridge needs replacement. It flashes when the cartridge is installed incorrectly. Otherwise the light is off.
3. The red Paper-Out light is on and steady when the printer is out of paper or the paper tray is missing. The light flashes when the printer is ready to accept manually fed paper.
4. The red Paper Jam light comes on and stays lit when paper jams. The light will stay on until the jam is cleared.
5. When both the red Paper-Out and Paper Jam lights flash, the controller-I/O board or the LaserWriter print engine has an error condition.

Note: Refer to Section 4, Troubleshooting for status LED diagnostic information.

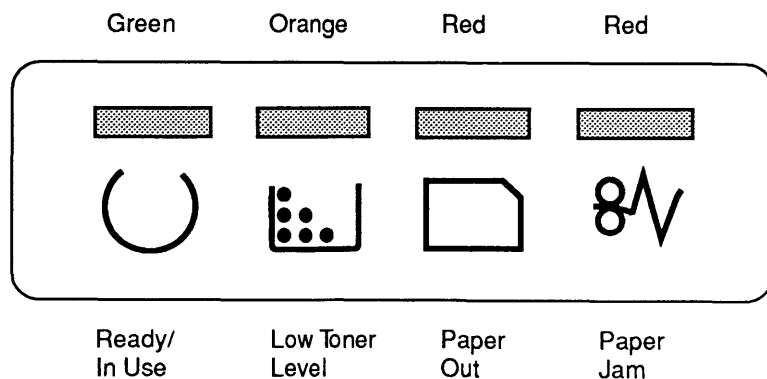

Figure 1-20 Status LEDs

□ TONER CARTRIDGE

The toner cartridge includes a photosensitive drum, primary corona assembly, developing unit, and drum-cleaning unit. During printing, the drum rotates as an electrostatic image forms on its surface. The printer toner adheres to the electrostatic image and then transfers to paper to make the print. The toner cartridge cannot be disassembled (**Figure 1-21**).

The printing life of a cartridge is approximately 4000 copies. To help maintain high-quality printing, the printer will periodically start, as though about to print. This action will rotate the photosensitive drum and redistribute the toner.

Refilled toner cartridges may produce prints of inferior quality. Use only newly supplied Apple toner cartridges.

Note: The toner cartridge used in the LaserWriter II printer is **not** interchangeable with the toner cartridges for the LaserWriter or LaserWriter Plus printers. For optimum print quality, use Apple-supplied toner cartridges.

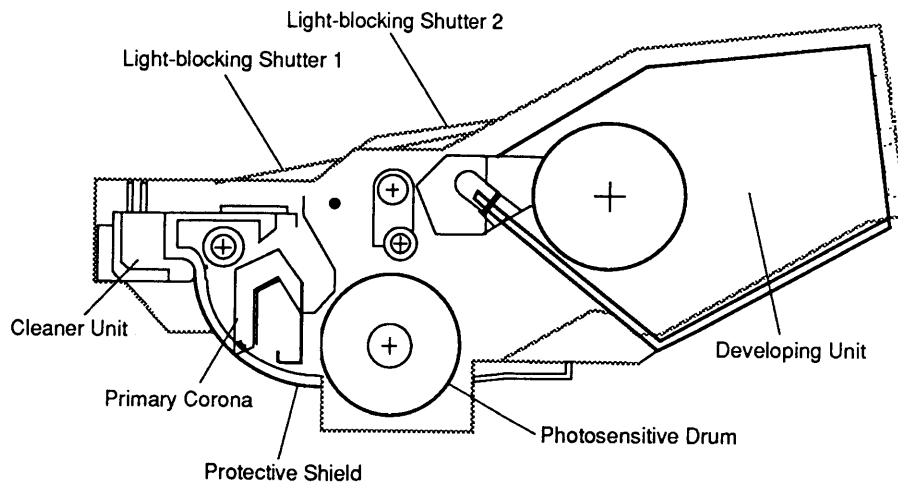

Figure 1-21 Toner Cartridge

Protective Shield

A shield protects the photosensitive drum from exposure to strong light when the cartridge is out of the printer. If the drum is exposed to strong light for a long period, blank areas or black streaks may appear on prints (see Section 4, Troubleshooting).

The shield automatically opens when you insert the toner cartridge and close the printer. Do not open the protective shield.

Light-Blocking Shutters

Light-blocking shutters 1 and 2 also protect the photosensitive drum. These shutters prevent light from entering the drum when you remove the toner cartridge. If the shutters fail to close when you remove the cartridge, close them manually. The shutters open automatically when you insert the cartridge into the printer.

Storage

Storage requirements are as follows:

- The toner cartridge should be stored at a temperature between 32°F and 95°F (0°C and 35°C) and at a relative humidity of 35% to 85%. Higher or lower temperature or humidity may reduce the storage life of the cartridge.

Note: The toner cartridge has a useful life of 2.5 years from the date of manufacture (printed on the cartridge). The limit of life (date of manufacture plus 2.5 years) is on the toner cartridge box.

- Do not store in direct sunlight or inside a vehicle for an extended time.
- Do not store where temperature and humidity are subject to abrupt changes.
- Do not store near corrosive gases (ammonia, etc.) or salt air.
- Do not store near devices that generate a magnetic field (such as TVs, microwave ovens, and motors).

Handling Procedure

Service technicians and end users should be aware of the following handling procedure:

- While installing a cartridge, hold the cartridge horizontal and slowly rock it about the axis of the drum 45 degrees five times in each direction (**Figure 1-22**). This movement will distribute the toner evenly. Don't stand the cartridge on end or turn it upside down. The caution label should always face up.

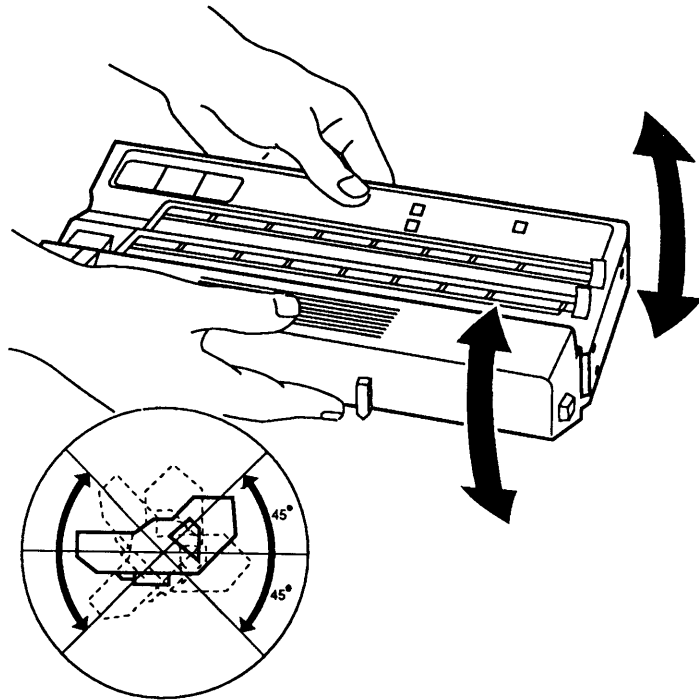

Figure 1-22 Distributing the Toner

□ SETUP AND OPERATION

Setup and operation instructions for the LaserWriter II SC, NT, NTX, f, and g are in the respective user manuals. The manuals cover the following topics:

1. **Setting Up the LaserWriter II:** includes procedures for installing the toner cartridge, installing the cleaning pad, loading the paper cassette, installing the manual feed guide, and installing the paper cassette.
2. **Connecting the LaserWriter II:** depending on the model type, includes instructions for connecting the printer directly to the Macintosh, to a LocalTalk network, or to an Ethernet network.
3. **Software Installation:** includes information on installing printer drivers, installing fonts, and managing disk space. Depending on the model type, the manual may also include procedures for installing additional fonts, creating application disks, naming the printer, downloading PostScript files, and using printer features (e.g., FinePrint and PhotoGrade).
4. **Using the LaserWriter II:** provides instructions for using the Chooser, automatic-feed printing, manual feed printing, and adding and removing fonts and desk accessories. The manual may also include information on print options, page setup, printing from the Finder, and printing color or grayscale documents.
5. **All About Fonts:** if included, this section covers various aspects of the fonts used with the printer.
6. **Designing with the LaserWriter II:** if included, this section covers font selection, page organization, presentations, forms, reports, mailings, and suggestions for further reading.
7. **End-User Maintenance and Troubleshooting:** covers routine cleaning and maintenance procedures, safety precautions, and troubleshooting guidelines.

□ TEST PAGES

The LaserWriter II produces several kinds of test pages. The controller-I/O board generates the startup test page whenever the printer is switched on. Technicians can generate the engine self-test page when performing maintenance or repair procedures. The calibration test page, which only the II_f and II_g printers produce, is used to fine-tune the PhotoGrade setting.

Engine Self-Test Page

To print an engine self-test page (**Figure 1-23**), press the engine self-test switch at the lower rear of the printer, behind the access cover. The DC controller PCA generates this test page exclusively. It is useful in service situations where you need to isolate print engine failures from controller-I/O board failures. The print consists of vertical black stripes on a white background. The stripes cover the entire printable area of the page.

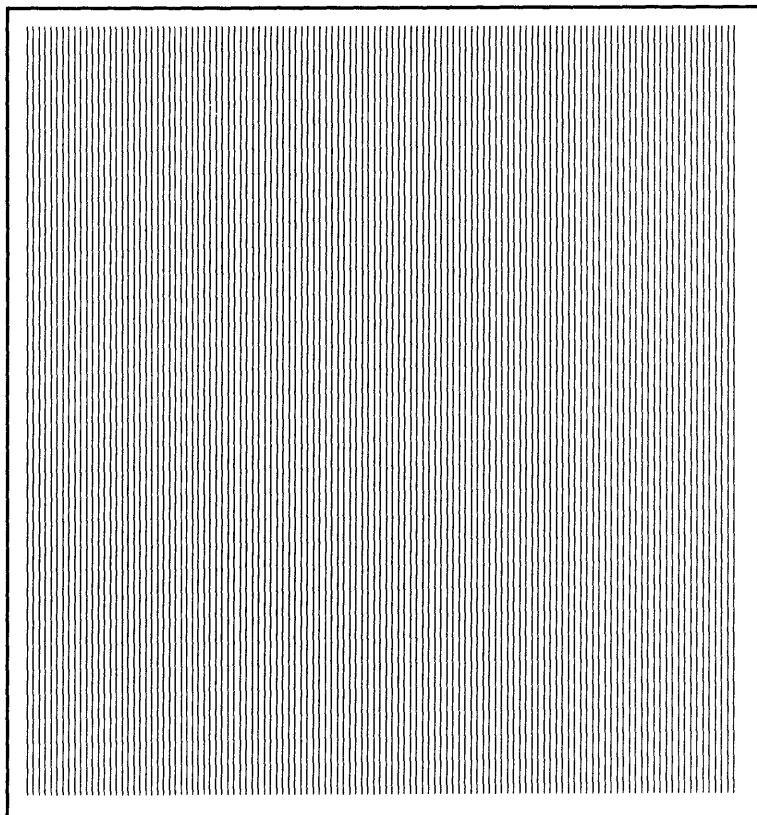

Figure 1-23 Engine Self-Test Page

SC Startup Test Page

The LaserWriter II SC generates a startup test page (**Figure 1-24**) whenever the SCSI ID number is set to 7. The SC startup test page confirms the operation of the SC controller-I/O board.

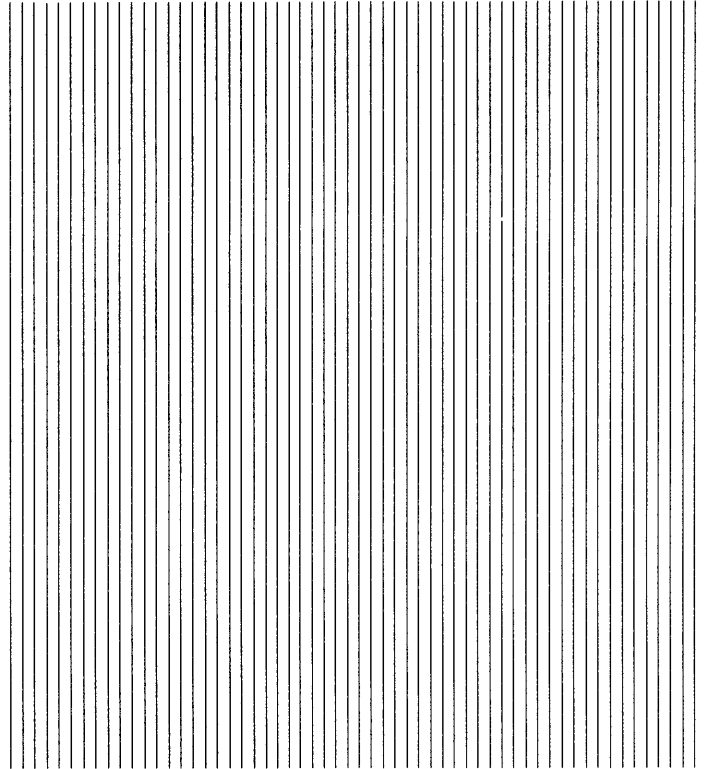

Figure 1-24 SC Startup Test Page

NT/NTX Startup Test Page

The LaserWriter II NT and NTX generate a startup test page (**Figure 1-25**) each time they are switched on (unless PostScript software or the LaserWriter II utility turns the function off). The startup test page confirms the operation of the NT or NTX controller-I/O board and provides the following information about the configuration and status of the printer:

1. The name of the printer. This is the name of the printer selected by using the Chooser.
2. The type of controller-I/O board—either NT or NTX.

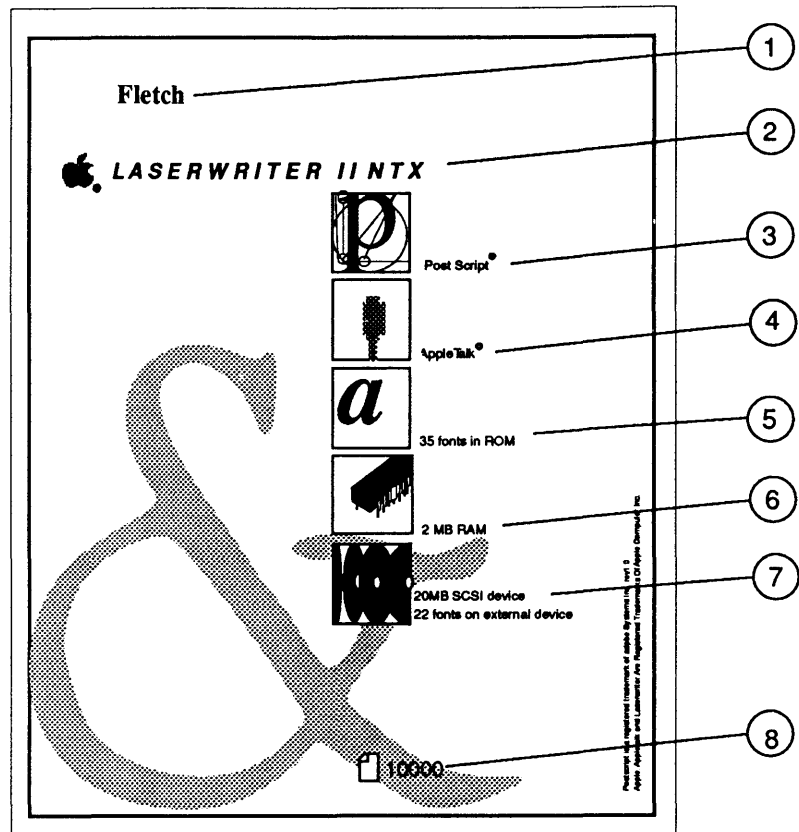

Figure 1-25 NT/NTX Startup Test Page

3. Whether the controller-I/O board is configured for PostScript, Diablo 630, or Hewlett-Packard LaserJet Plus™ emulation (NTX only).
4. Whether RS-232 serial or AppleTalk communication is selected.
5. How many built-in fonts are in ROM.
6. The amount of RAM installed. The NTX can be configured for between 2 MB and 12 MB. The NT has 2 MB.
7. An icon appears when an initialized hard disk is connected to the SCSI port. The size of the drive and the number of fonts it contains also appear (NTX only).
8. The number of pages the controller-I/O board has produced.

IIf and IIg Startup Test Pages

The LaserWriter IIf and IIg generate a startup test page (Figure 1-26) each time they are switched on (unless the user switches the function off via PostScript software or the LaserWriter II utility application). The startup test page confirms the operation of the controller-I/O board and provides the following information about the configuration and status of the printer:

1. The name of the printer, which is selected via the Chooser.
2. The type of controller-I/O board (either IIf or IIg).

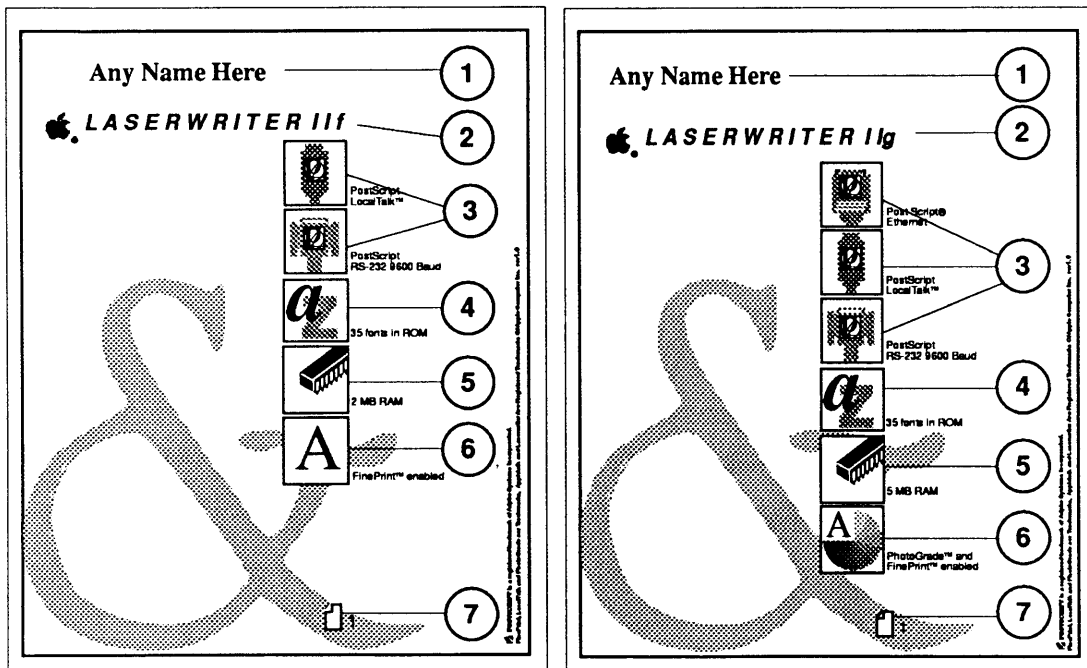

Figure 1-26 IIf and I Ig Startup Test Pages

3. The communication parameters and printer control language (PCL) selected for an individual printer port.
4. How many built-in fonts are in ROM.
5. The amount of RAM installed. The Iif can have 2 MB to 32 MB of RAM; the IIg can have 5 MB to 32 MB of RAM.
6. Whether the FinePrint and/or PhotoGrade features are enabled.
7. The number of pages the controller-I/O board has produced.

□ ELECTROSTATIC DISCHARGE (ESD) PRECAUTIONS

Why Prevent ESD?

Electrostatic Discharge (ESD) can cause severe damage to sensitive microcircuits. Touching a chip or brushing it with a nylon sleeve can degrade a circuit so that it never again performs to specification. Some microcircuits are sensitive to as little as 500 volts, or about one-sixth as much static electricity as you can feel.

ESD Rules

You must take preventive measures to avoid ESD damage. When you unwrap, install, or replace microcircuits, observe the following precautions:

Grounds

Before working on any device containing a printed circuit, ground yourself and your equipment to an earth or building ground.

Use a grounded conductive workbench mat and a grounding wriststrap, and ground your equipment to the mat.

WARNING: *Make sure you are not grounded when working on "live" (plugged-in) equipment or when discharging a cathode-ray tube (CRT).*

Bodies

Don't touch anybody who is working on integrated circuits.

If that person is properly grounded, your "zap" may not cause any damage, but to be on the safe side, keep your own body charge away from other technicians.

Bags

Use static-shielding bags for boards and chips during storage, transportation, and handling.

Before you leave your bench to take a board to a storage place, put the board in a static-shielding bag. Leave all Apple service exchange components in their ESD-safe packaging until needed.

Leads

Handle all ICs by their bodies, not their leads.

Also, do not touch PCA edge connectors, exposed circuitry, or printed circuits. Handle ICs and PCAs by the corners, or use extractors.

Synthetics

Do not wear polyester clothing or bring plastic, vinyl, or Styrofoam into the work environment.

The electrostatic field around these nonconductors cannot be removed.

Metals

Never place components on a metal surface.

Use antistatic or conductive mats or foam.

Atmosphere

If possible, keep the humidity in the service area between 70% and 90%, and use an ion generator.

Charge levels are reduced (but not eliminated) in high-humidity environments and in areas where an ion generator is used routinely.





LaserWriter II

Section 2 – Take-Apart

□ CONTENTS

	2.3	Introduction
	2.3	Materials Required
	2.3	Before Beginning
	2.3	Safety Precautions
	2.4	Orientation
	2.4	Screw Types
	2.4	Plastic Assemblies
	2.4	Electrostatic Discharge Precautions
Covers and Panels	2.5	Covers and Panels
	2.5	Cover Set
	2.6	Front Panel
	2.7	Lower Right Panel
	2.7	Rear Panel
	2.7	Upper Right Panel
	2.8	Release Button
	2.8	Bottom Panel
	2.9	Lower Cover
Print Engine	2.10	Status Panel
	2.11	Fuser Assembly
	2.12	Heater Bulb
	2.19	Fuser Delivery Assembly
	2.20	Delivery Roller
	2.22	Delivery Sensing Lever
	2.23	Power Supply Block
	2.24	Upper Fan
	2.26	Fan Bushing/Bearing
	2.27	Ozone Filter
	2.29	Laser/Scanner Assembly
	2.31	High-Voltage Power Supply Assembly
	2.34	DC Power Supply
	2.37	Distribution PCA
	2.38	Main Motor Assembly
	2.39	Drive Gear Assembly

- 2.40 Transfer Guide Assembly
- 2.41 Separation Pad
- 2.42 Transfer Corona Assembly
- 2.43 Restraining Corona Wire
- 2.45 Paper Feed Assembly
- 2.46 Pickup Roller
- 2.48 Paper Feed Drive Assembly
- 2.50 Feeder Assembly
- 2.52 Feeder Guide Gear (24 Tooth)
- 2.53 Pressure Assembly
- 2.55 Paper Pickup Gear (19 Tooth)
- 2.57 Paper Pickup Gear (57 Tooth)
- 2.58 Left Hook
- 2.59 Left Lifter
- 2.60 Left Hook Guide
- 2.61 Right Hook
- 2.62 Right Lifter
- 2.63 Right Hook Guide
- 2.64 Paper Sensing Arm
- 2.65 Auxiliary Guide

Lower Print Engine

- 2.66 Controller-I/O Board
- 2.68 DC Controller PCA
- 2.71 Connector PCA
- 2.72 Lower Fan

Upper Print Engine

- 2.73 Top Cover
- 2.75 Main Tray
- 2.76 Heater Cover
- 2.77 Shutter Assembly
- 2.78 Shutter Arm
- 2.79 Mirror Assembly
- 2.82 Delivery Assembly
- 2.84 Delivery Coupler Assembly
- 2.85 Static Charge Eliminator
- 2.86 Preconditioning Exposure Assembly
- 2.88 Copy Tray
- 2.89 Paper Deflector

□ INTRODUCTION

Materials Required

Disassembling and assembling the LaserWriter II requires only a small number of common hand tools. You will need:

- #1 Phillips screwdriver, medium shank
- #2 Phillips screwdriver, medium shank
- #2 Phillips screwdriver, short shank
- Small flatblade screwdriver, short shank
- Needlenose pliers
- Grip-ring pliers
- Diagonal cutters

Before Beginning

Before you begin servicing the LaserWriter II, be sure to do the following:

- Power off and unplug the printer.
- Prepare your workstation for electrostatic discharge (ESD) prevention.
- Remove the paper cassette.
- Remove the toner cartridge.

Safety Precautions

1. **Always** unplug the printer before taking it apart.
2. **Never** disconnect the optical fiber from the DC controller PCA or remove it from the laser/scanner assembly when the printer is turned on. The fiber carries infrared laser radiation, which you cannot see but which can permanently damage your eyes or someone else's. Even if you don't look directly at the fiber, the light can enter the eye by bouncing off reflective surfaces.
3. Whenever the printer is plugged in and the covers are removed, be careful where you put your hands. There are dangerous voltages in and around the Power Supply Block, DC Power Supply, and High Voltage Power Supply.
4. Warning labels appear in locations on the printer wherever special attention is needed. **Obey the instructions on the labels.**

Orientation

All references to position assume the printer is sitting with the paper cassette slot on your right and the power switch at the left rear.

Screw Types

All screws used in the LaserWriter II are Phillips screws. When removing screws, pay attention to the type of screw removed and replace the same type in the same position. The following chart describes each of the main types of screws used in the LaserWriter II:

Type	Use
Binding head, nickel	Fastening metal to metal
Binding head, black	Fastening metal or plastic to plastic
Washer head, nickel	Fastening metal to metal when a washer is required
Washer head, black	Fastening plastic to metal or metal to metal when no electrical contact is needed
Self-tapping, black	Fastening plastic parts to plastic casting when self-tapping required

Plastic Assemblies

Screws are used in a variety of places to hold plastic assemblies together. **Do not** overtighten these screws. Doing so can cause permanent damage to the assembly.

Electrostatic Discharge Precautions

Be sure to follow the ESD prevention information located in Section 1, Basics to avoid damage to any LaserWriter II electronics.

□ COVERS AND PANELS

Materials Required

#2 Phillips screwdriver

Cover Set

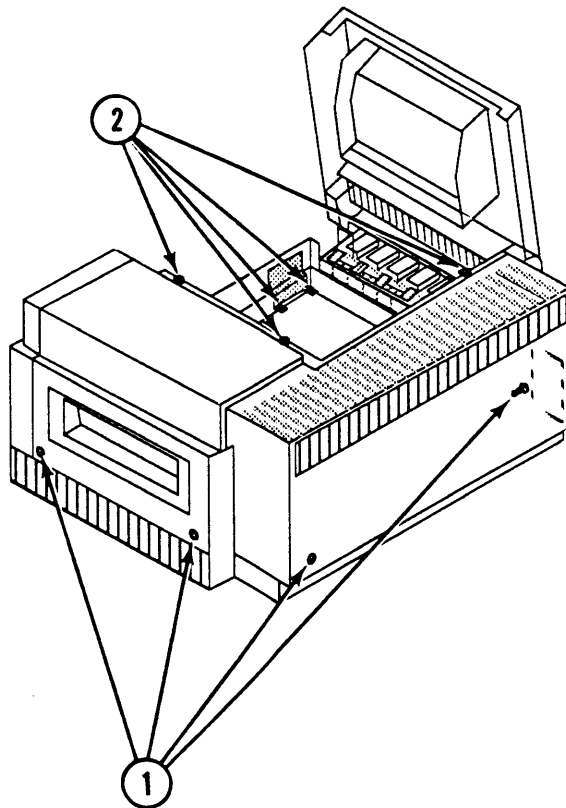

FIGURE 1

1. Remove the four exterior Phillips screws (Figure 1, #1) that secure the cover set to the printer.
2. Depress the release button and open the top cover of the printer.
3. Remove the five interior Phillips screws (Figure 1, #2).

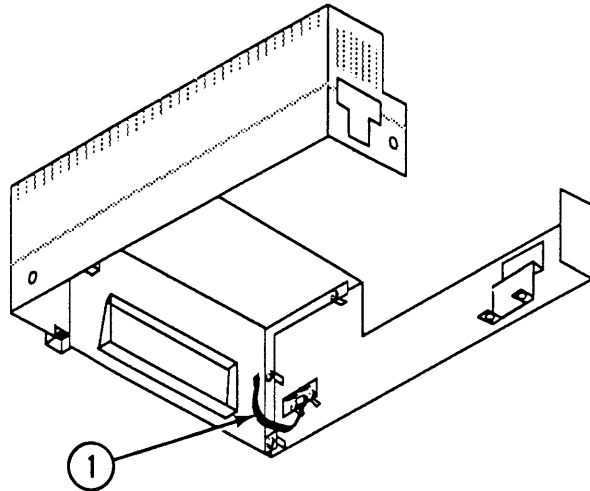

FIGURE 2

4. Lift the cover set straight up and remove it from the printer far enough to disconnect the cable (Figure 2, #1) from the status panel.

Front Panel

1. Remove the cover set.

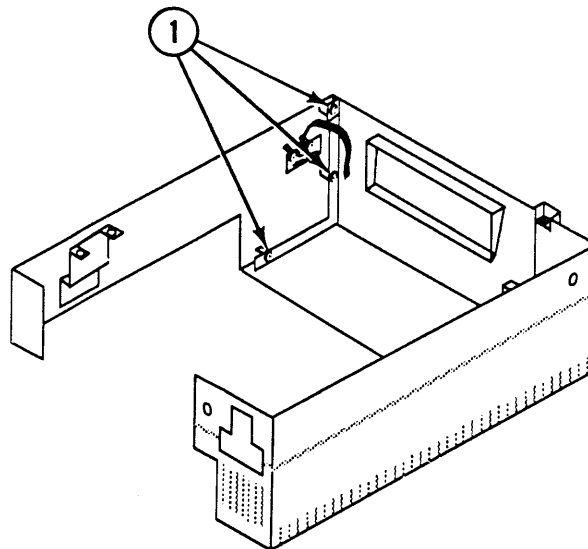

FIGURE 3

2. Remove the three Phillips screws (Figure 3, #1) that secure the front panel to the upper right panel.

**Lower Right
Panel**

1. Remove the cover set.

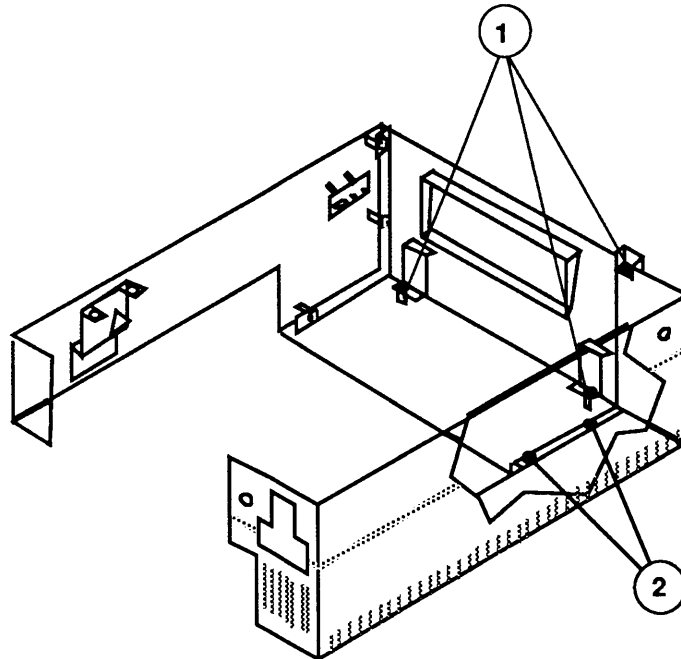

FIGURE 4

2. Remove the three Phillips screws (Figure 4, #1) that secure the lower right panel to the upper right panel.
3. Lift the edge of the rear panel away from the lower right panel and remove the lower right panel.

Rear Panel

1. Remove the cover set.
2. Remove the three Phillips screws (Figure 4, #2) that secure the rear panel to the upper and lower right panels.

**Upper Right
Panel**

Remove the front, lower right, and rear panels.

Release Button

1. Remove the cover set.
2. Press the arms of the release button inward and remove the release button.

Bottom Panel

1. Remove the controller-I/O board.
2. Carefully place the printer on its back on a padded work surface.

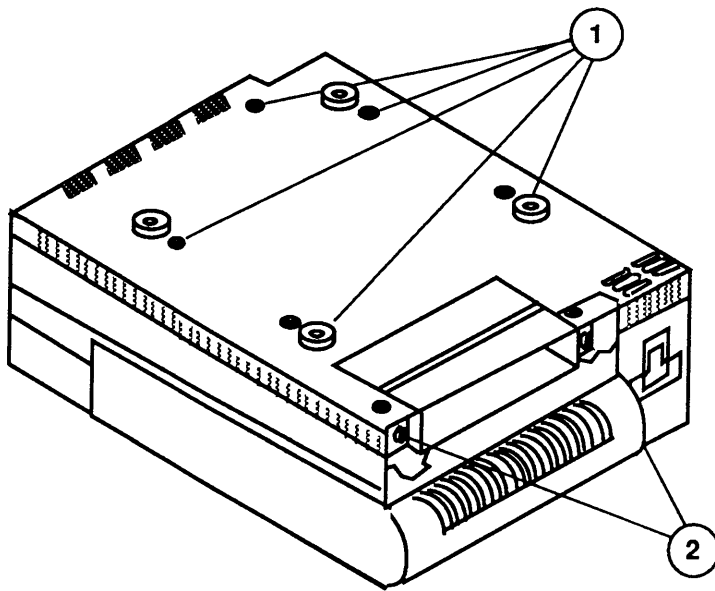

FIGURE 5

3. Remove the seven Phillips screws (Figure 5, #1) that secure the bottom panel to the lower cover. Remove the bottom panel.

Lower Cover

1. Remove the bottom panel.
2. Remove the two Phillips screws (Figure 5, #2) that secure the shield plate to the lower cover, and remove the shield.

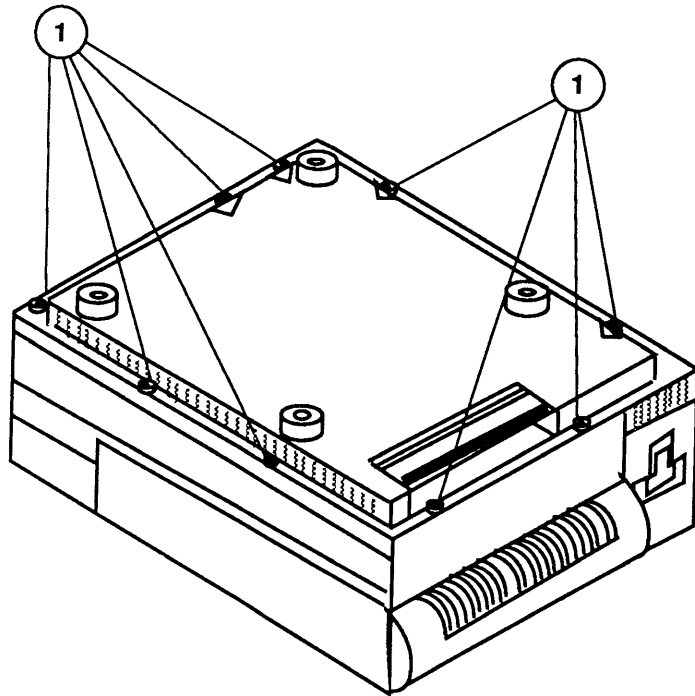

FIGURE 6

3. Remove the nine Phillips screws (Figure 6, #1) that secure the lower cover to the chassis of the printer.
4. Pull the right side of the lower cover away from the chassis and slide the cover to the left to clear the controller-I/O board guide rails. Remove the lower cover.

□ STATUS PANEL

Materials Required

#2 Phillips screwdriver

Remove

1. Remove the cover set.

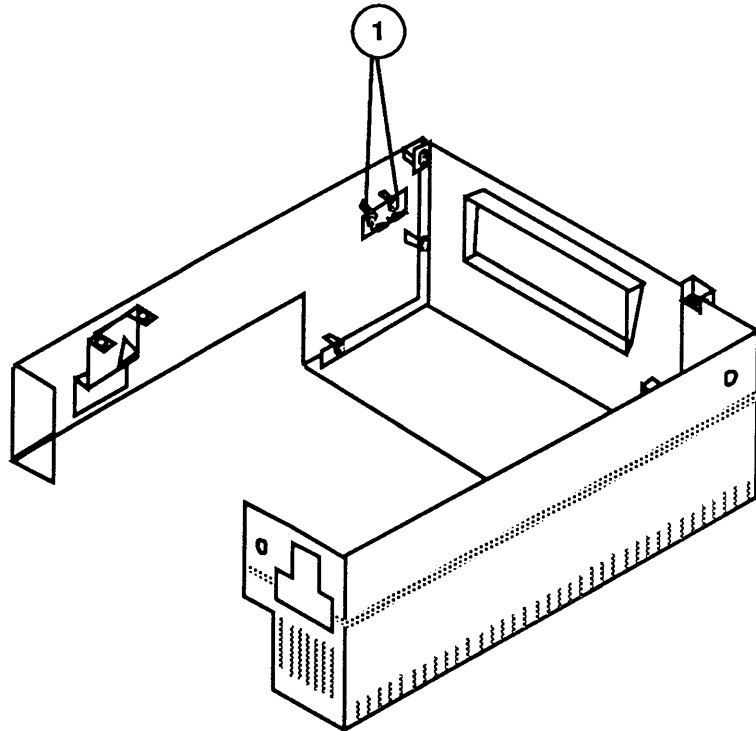

FIGURE 7

2. Remove the two Phillips screws that secure the status panel to the front panel (Figure 7, #1).

Replace

1. Place the status panel in position on the front panel. The connector should be toward the bottom of the front panel.
2. Replace the two Phillips screws that secure the status panel to the front panel.
3. Replace the cover set.

□ FUSER ASSEMBLY

Materials Required

#2 Phillips screwdriver

Remove

1. Depress the release button and open the top cover.

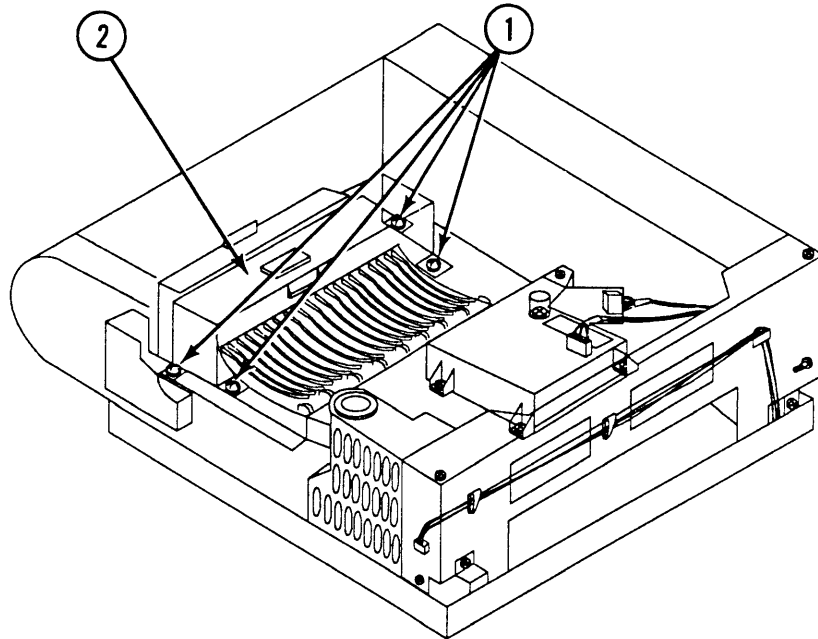

FIGURE 8

2. Remove the four Phillips screws (Figure 8, #1) that secure the fuser assembly (Figure 8, #2) to the chassis.
3. Lift the fuser assembly straight up and remove it from the printer.

Replace

1. Place the fuser assembly in position and align the connector pins at each end of the fuser with the mating connectors in the printer.

Note: Make sure the 7-pin connector at the front of the printer mates properly with its receptacle.

2. Replace the four fuser assembly screws (Figure 8, #1).

□ HEATER BULB

Materials Required

#2 Phillips screwdriver
Small, flatblade screwdriver or grip-ring pliers

Remove

1. Remove the fuser assembly.

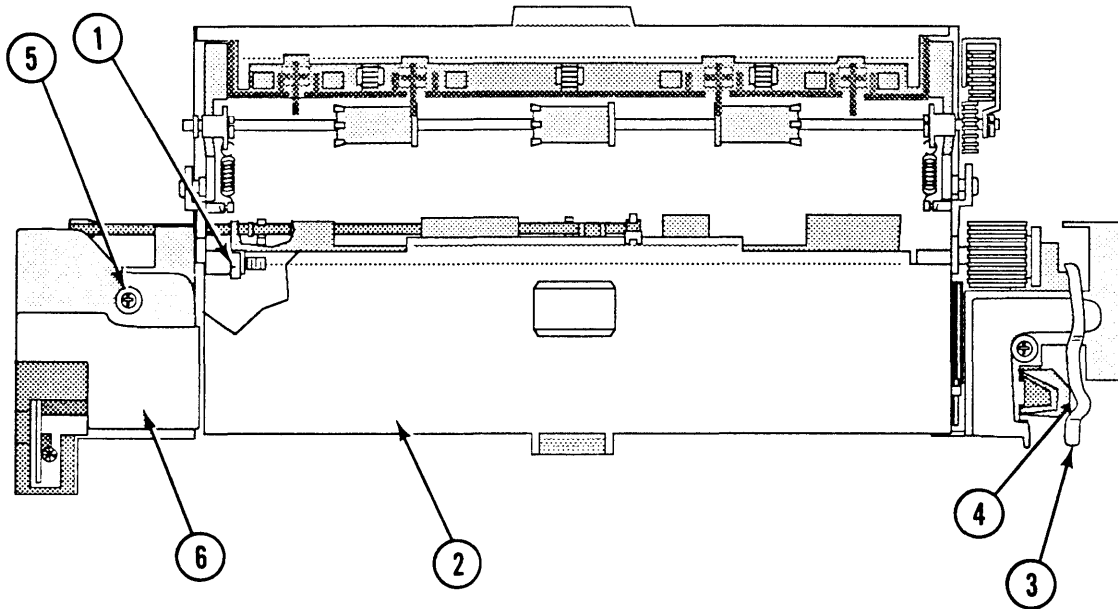

FIGURE 9

2. Loosen the Phillips screw (Figure 9, #1) that secures the fuser cover (Figure 9, #2) to the fuser assembly. Remove the fuser cover.
3. Remove the fuser cleaning felt.
4. Using the screwdriver or grip-ring pliers, remove the E-ring (Figure 9, #3) that secures the drive release cam to the fuser assembly.
5. Remove the drive release cam (Figure 9, #4) and the spring.
6. Remove the Phillips screw (Figure 9, #5) that secures the left contact cap (Figure 9, #6) to the fuser assembly. Remove the cap.

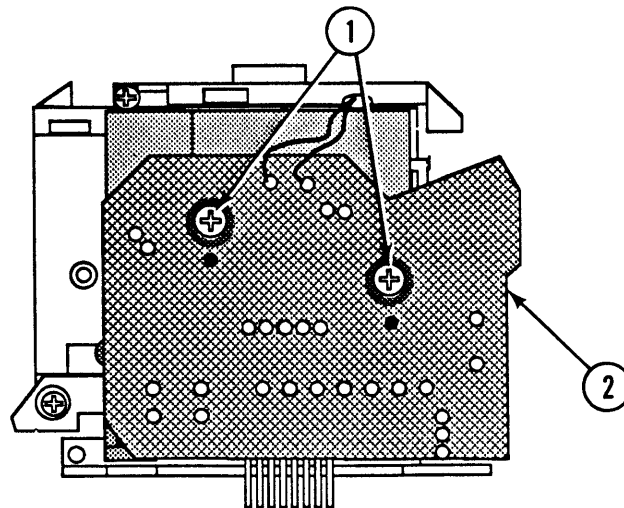

FIGURE 10

7. Remove the two Phillips screws (Figure 10, #1) that secure the fuser PCA (Figure 10, #2) to the fuser assembly. Remove the fuser PCA.

Note: The fuser PCA will still be attached to the fuser assembly after removal. Be careful when handling either part.

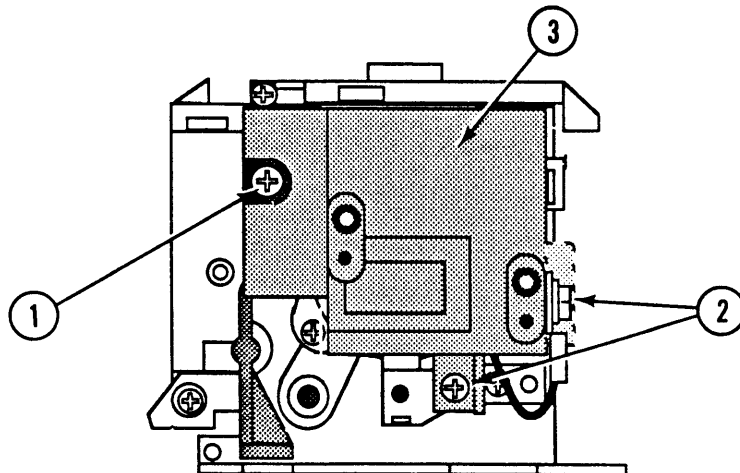

FIGURE 11

8. Remove the three Phillips screws (Figure 11, #1 and #2) that secure the left terminal mount (Figure 11, #3) to the fuser assembly. Remove the terminal mount.

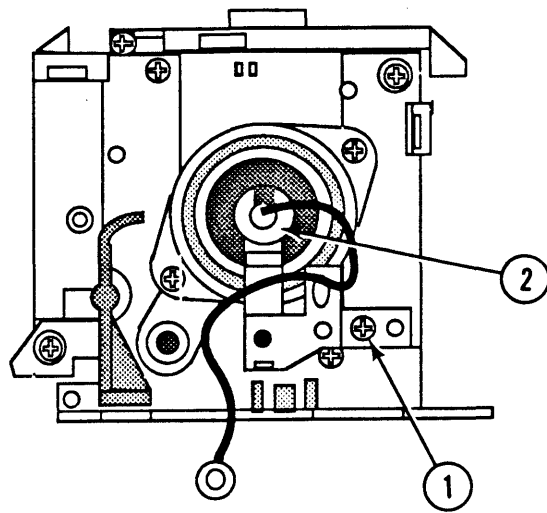

FIGURE 12

9. Remove the Phillips screw (Figure 12, #1) that secures the left heater support (Figure 12, #2) to the fuser assembly. Remove the support.

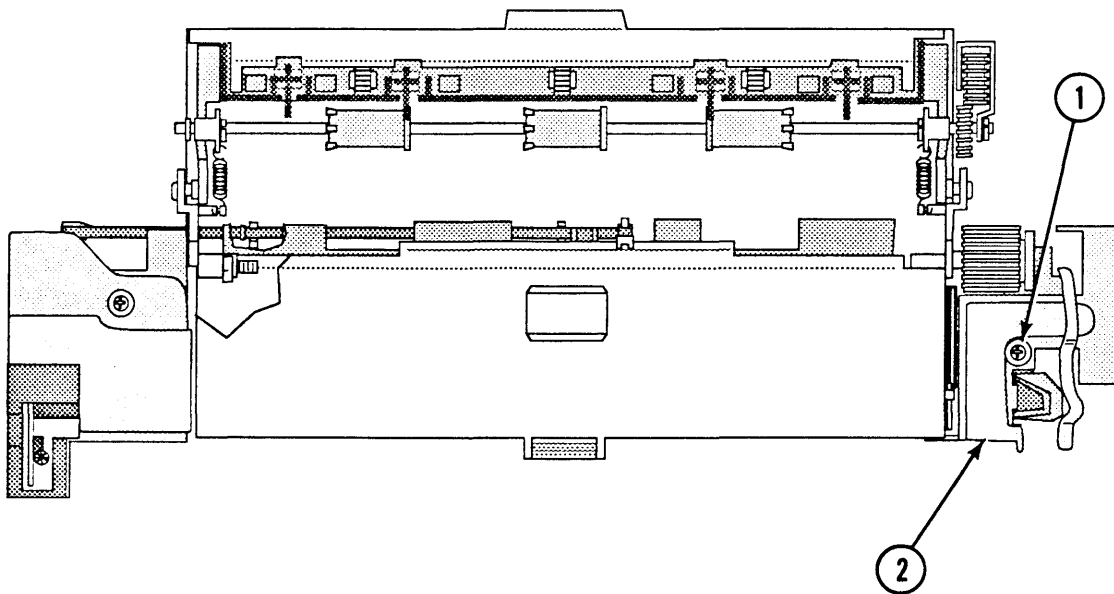

FIGURE 13

10. Remove the Phillips screw (Figure 13, #1) that secures the right contact cap (Figure 13, #2) to the fuser assembly. Remove the cap.

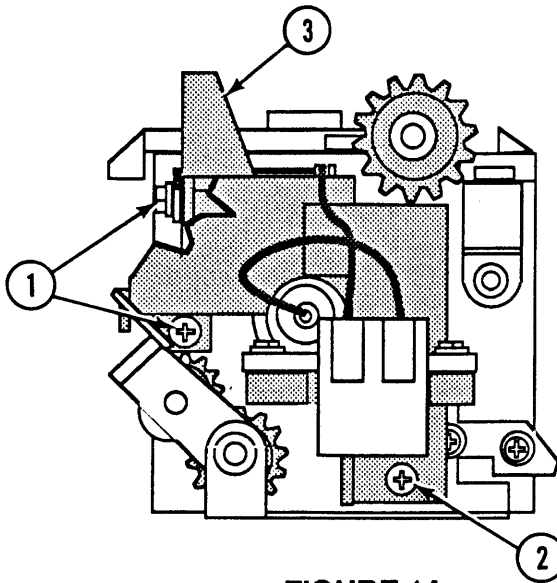

FIGURE 14

11. Remove the three Phillips screws (Figure 14, #1 and #2) that secure the right terminal mount (Figure 14, #3) to the fuser assembly. Remove the terminal mount.

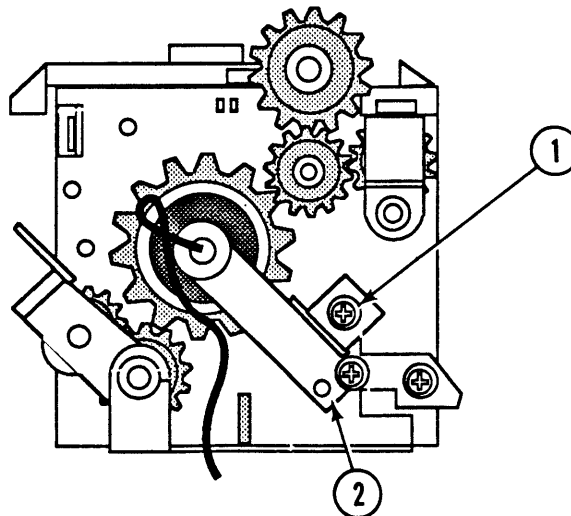

FIGURE 15

12. Remove the Phillips screw (Figure 15, #1) that secures the right heater support (Figure 15, #2) to the fuser assembly.
13. Remove the heater bulb. Be **careful** not to break the bulb as you remove it.

Replace

1. Place the heater bulb in position by sliding the bulb into the fuser assembly from the end where the drive release cam is.

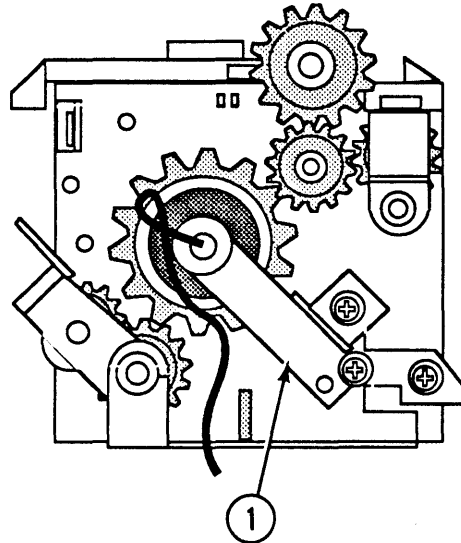

FIGURE 16

2. Place the right heater support (Figure 16, #1) in position and replace the Phillips screw.

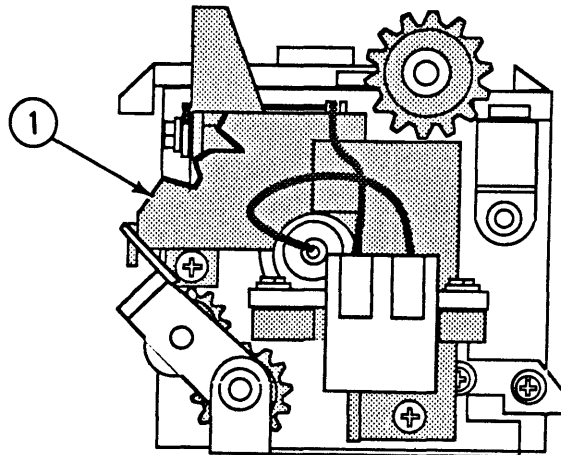

FIGURE 17

3. Place the right terminal mount (Figure 17, #1) in position and replace the three Phillips screws.
4. Place the right contact cap in position and replace the Phillips screw.

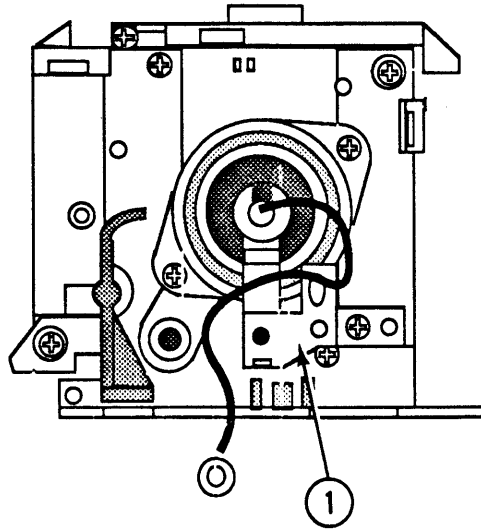

FIGURE 18

5. Place the left heater support (Figure 18, #1) in position and replace the Phillips screw.

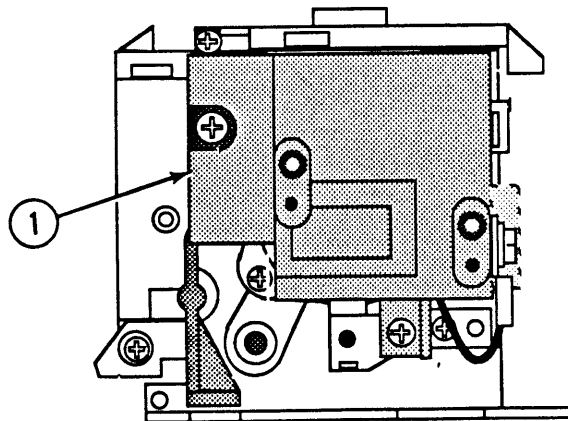

FIGURE 19

6. Place the left terminal mount (Figure 19, #1) in position and replace the three Phillips screws.
7. Place the fuser PCA in position and replace the two Phillips screws.
8. Place the left contact cover in place and replace the Phillips screw.

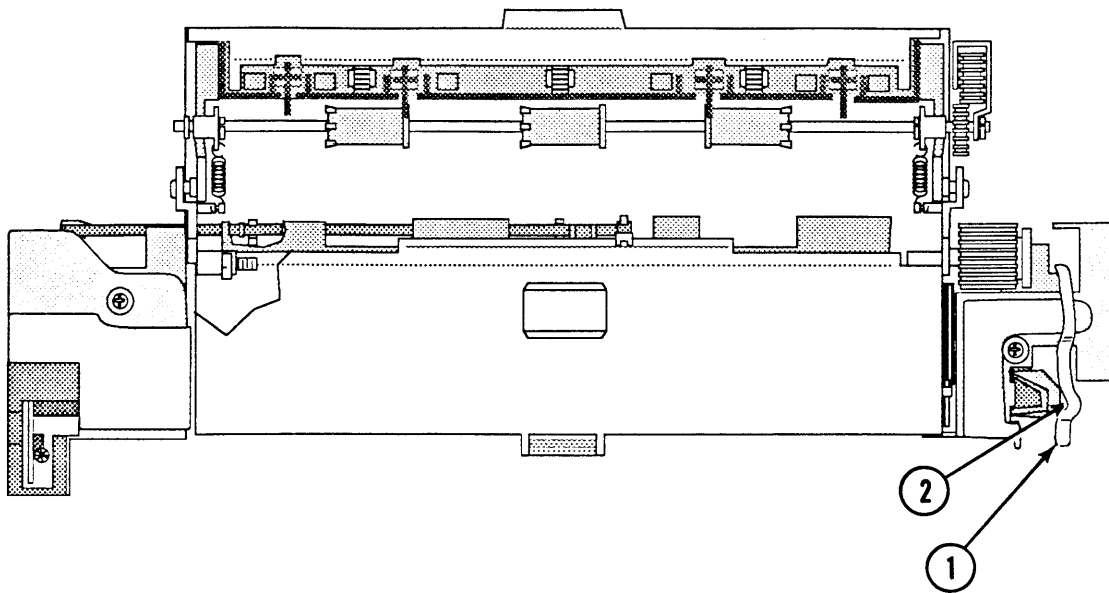

FIGURE 20

9. Replace the drive release cam (Figure 20, #1) and spring.
10. Replace the drive release cam E-ring (Figure 20, #2).
11. Replace the fuser cleaning felt.
12. Place the fuser cover in position and tighten the Phillips screws.
13. Replace the fuser assembly.

□ FUSER DELIVERY ASSEMBLY

Materials Required #2 Phillips screwdriver

Remove 1. Remove the fuser assembly.

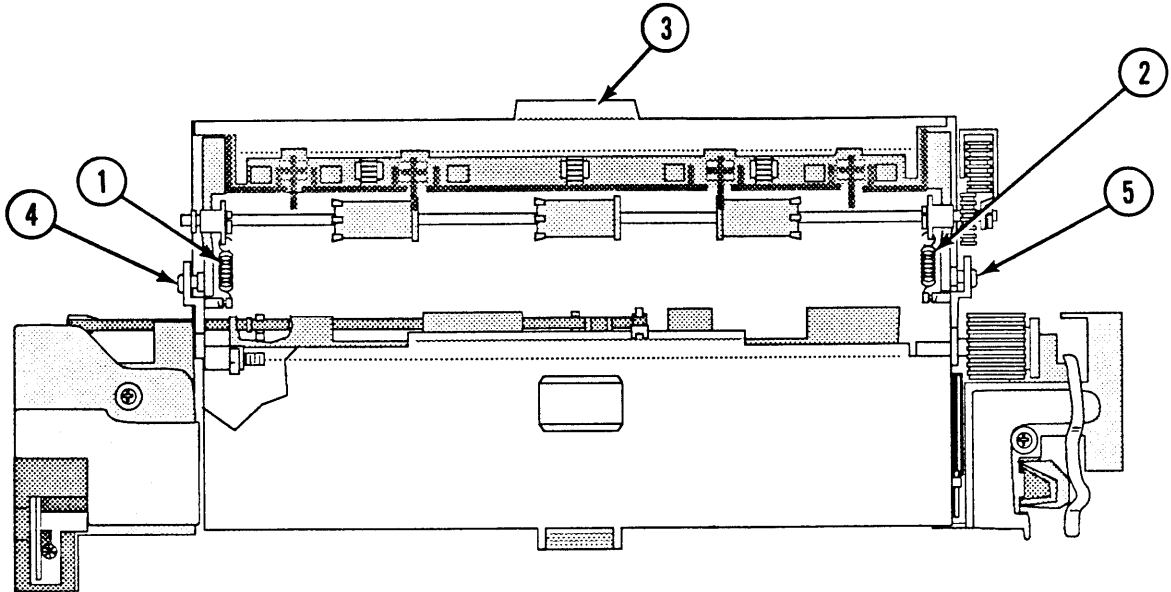

FIGURE 21

2. Unhook the two tension springs (Figure 21, #1 and #2) between the fuser delivery assembly (Figure 21, #3) and the bottom of the fuser assembly.
3. Remove the two Phillips screws (Figure 21, #4 and #5) that secure the fuser delivery assembly to the fuser assembly. Remove the fuser delivery assembly.

Replace

1. Place the fixing delivery assembly in position and engage the "arms" in their respective openings in the base of the fuser assembly.
2. Replace the two fixing delivery assembly screws.
3. Reinstall the two tension springs.
4. Replace the fuser assembly.

□ DELIVERY ROLLER

Materials Required

Small, flatblade screwdriver

Remove

1. Remove the fuser delivery assembly.

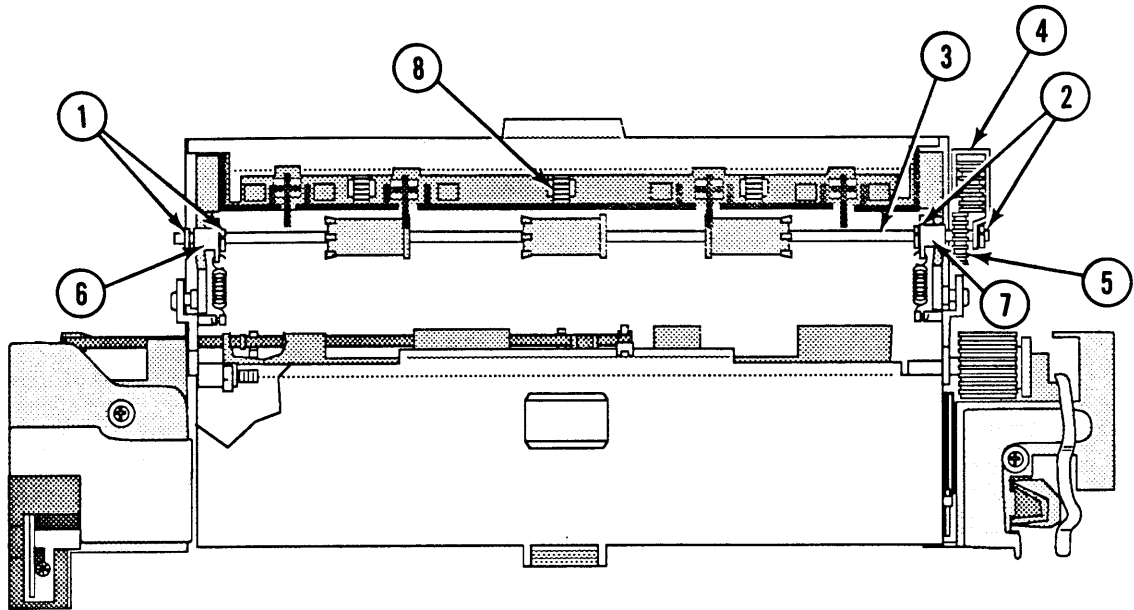

FIGURE 22

2. Using the screwdriver, remove the four C-rings (Figure 22, #1 and #2) that secure the delivery roller to the fuser delivery assembly.
3. Slide the delivery roller shaft (Figure 22, #3) away from the gear arm (Figure 22, #4) and lift the gear arm off the shaft.
4. Remove the delivery roller gear (Figure 22, #5) from the delivery roller shaft.

Note: Be careful not to lose the delivery roller gear pin.

5. Push the bushings (Figure 22, #6 and #7) toward the center of the delivery roller shaft.
6. Remove the delivery roller from the fuser delivery assembly.

Replace

1. Place the three upper delivery rollers (Figure 22, #8) into the openings in the fuser delivery assembly.
2. Place a bushing (Figure 22, #6 and #7) on each end of the delivery roller shaft so that the flat surface is toward the center of the shaft.
3. Place the delivery roller shaft in position in the delivery assembly. Push the bushings outward until they stop.
4. Slide the delivery roller gear pin into the hole in the delivery roller shaft. Hold the pin in position.
5. Slide the delivery roller gear into position.
6. Slide the delivery roller shaft away from the gear arm until it stops.
7. Place the gear arm over the delivery roller shaft.
8. Replace the C-ring on the delivery roller shaft at the gear arm.
9. Replace the remaining three C-rings on the delivery roller shaft.
10. Replace the fuser delivery assembly.

□ DELIVERY SENSING LEVER

The delivery sensing lever is a sensor located within the fuser assembly that detects whether paper is feeding normally. If paper fails to reach and clear the delivery sensing lever within a predetermined time, the DC controller powers off the main motor and turns on the paper jam status LED.

There are two versions of the delivery sensing lever. In the new version, the shape of the weight (Figure 23, #4) has been changed to correct an intermittent paper jam problem.

Remove

1. Remove the fuser assembly, and open the fuser delivery assembly.

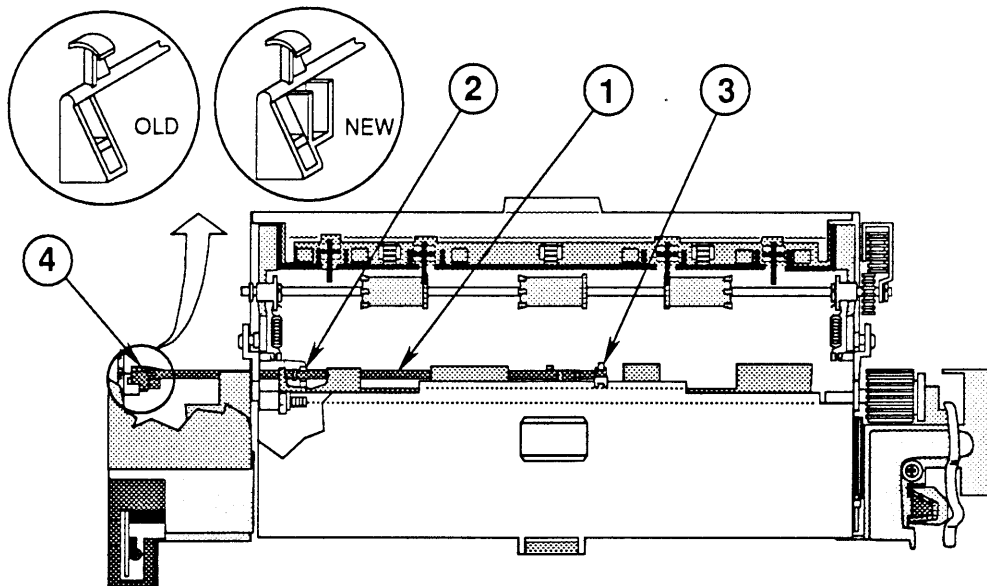

FIGURE 23

2. Carefully pull the delivery sensing lever (Figure 23, #1) out of the fuser assembly.

Replace

1. Place the delivery sensing lever in position (Figure 23, #2). Note that the end of the arm fits into the center holding tab (Figure 23, #3).
2. Replace the fuser assembly.

□ POWER SUPPLY BLOCK

Materials Required

#2 Phillips screwdriver

Remove

1. Remove the cover set and fuser assembly.

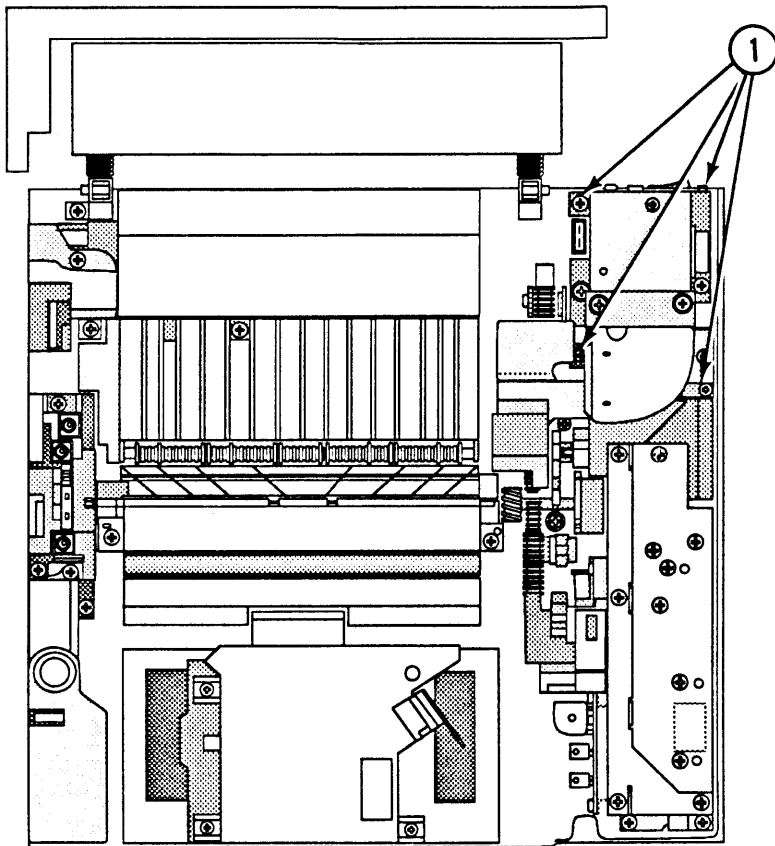

FIGURE 24

2. Remove the four Phillips screws (Figure 24, #1) that secure the power supply block to the chassis.
3. Lift the power supply straight up and remove it from the printer.

Note: If you are returning the power supply assembly to Apple, be sure to first remove the upper fan and fan duct.

Replace

1. Place the power supply in position and replace the four Phillips screws.
2. Replace the fuser assembly and cover set.

□ UPPER FAN

Materials Required

#2 Phillips screwdriver

Remove

1. Remove the cover set.

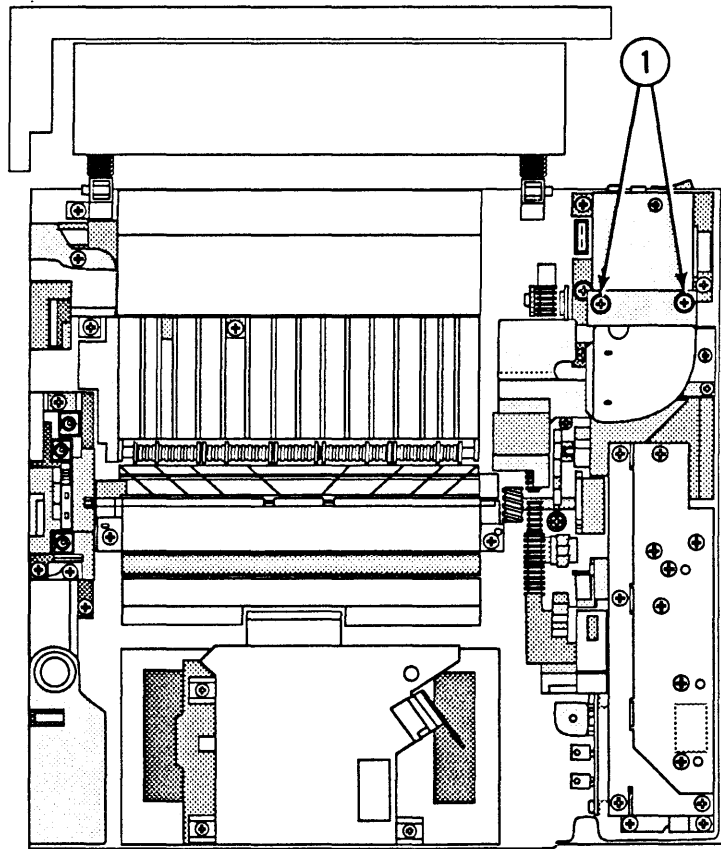

FIGURE 25

2. Remove the two Phillips screws (Figure 25, #1) that secure the filter case and fan duct to the power supply block. Remove the filter case and fan duct by pulling straight up.

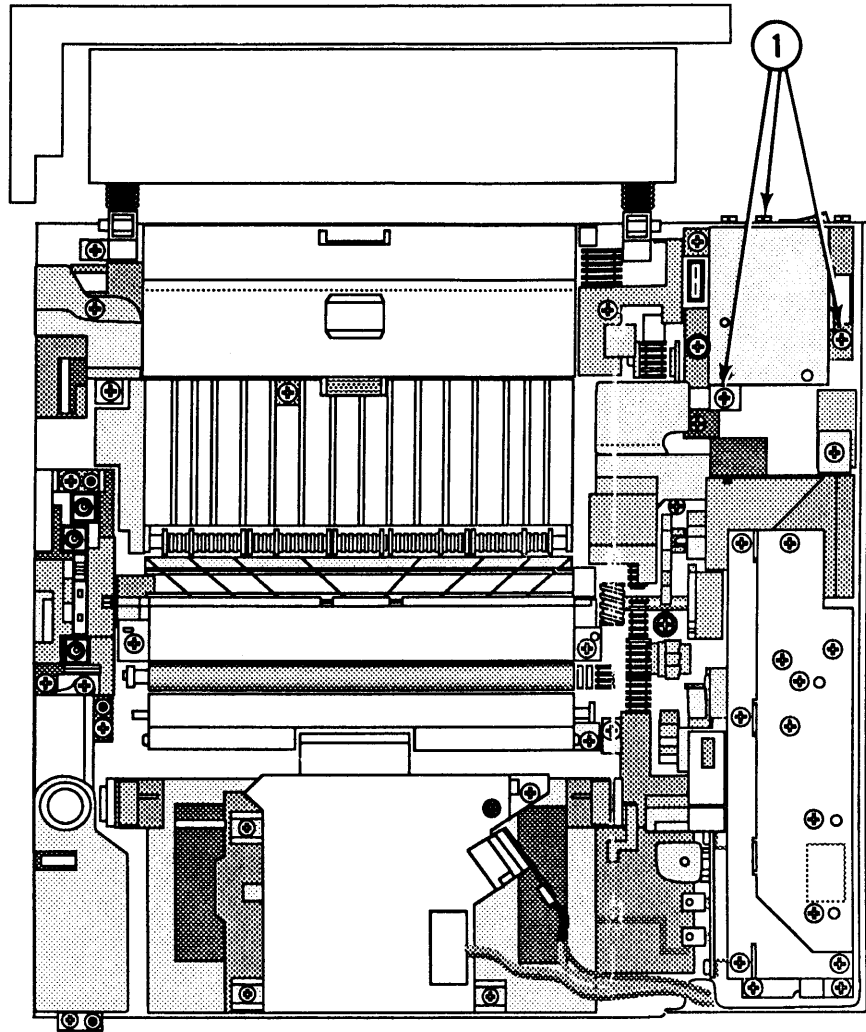

FIGURE 26

3. Remove the three Phillips screws (Figure 26, #1) that secure the fan to the power supply block, and remove the fan.

□ FAN BUSHING/BEARING

Two versions of the upper fan, supplied by two different vendors, are available for the LaserWriter II. The two fan versions differ in the design of the bushing/bearing installed on the fan and the size of the bushing/bearing opening. The Type "JP" bushing/bearing (Figure 27, #2) is 5/8 inches in diameter and rests flat against the side of the fan when installed. The Type "T" bushing/bearing (Figure 27, #1) is 7/8 inches in diameter with a knob that protrudes from the side of the fan when installed. The Type "T" and Type "JP" bushing/bearings are not interchangeable and must be replaced like-for-like.

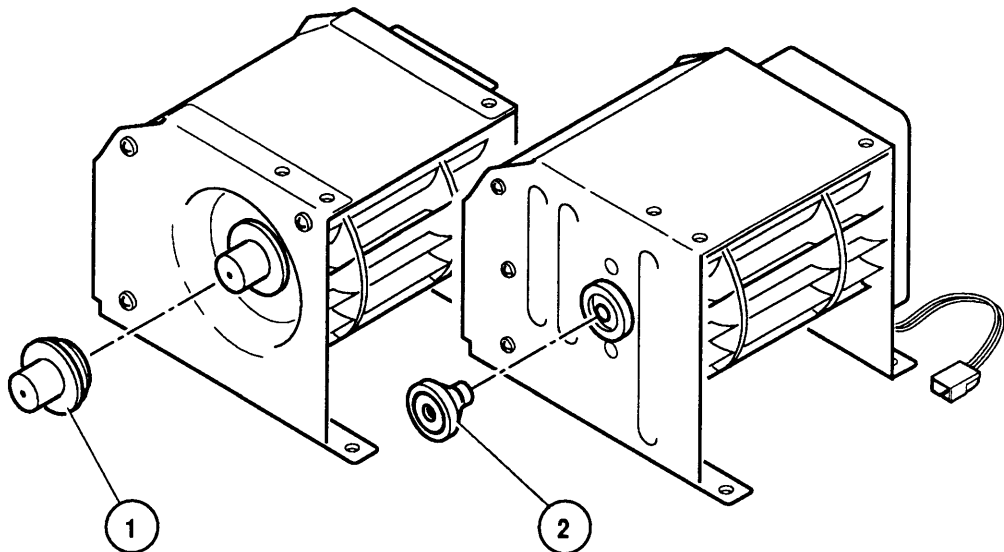

FIGURE 27

Materials Required

Jeweler's screwdriver
Needlenose pliers

Remove

1. Remove the cover set.
2. Using a jeweler's screwdriver or your fingers, carefully pry the edges of the rubber bushing away from the side of the fan.
3. When the rubber bushing is loose, pull the bushing/bearing off the fan motor shaft.

4. If the metal bearing was not removed with the rubber bushing, remove the metal bearing with needlenose pliers.

Replace

1. Place the new bushing/bearing on the fan motor shaft.
2. Using your fingertips, carefully push around the edges of the rubber bushing until the groove of the bushing completely fits the fan case.

WARNING: Do not push on the end of the protruding rubber knob when installing the Type "T" bushing/bearing. The metal bearing may pop out of the rubber bushing, resulting in incorrect installation.

3. Close the upper cover of the printer.
4. Switch on the power and confirm that the upper fan rotates properly:
 - a) Make sure that the fan doesn't squeak.
 - b) Make sure that air exists from the fan louver above the power switch at the back of the printer.

OZONE FILTER

Materials Required #2 Phillips screwdriver

- Remove**
1. Remove the cover set.

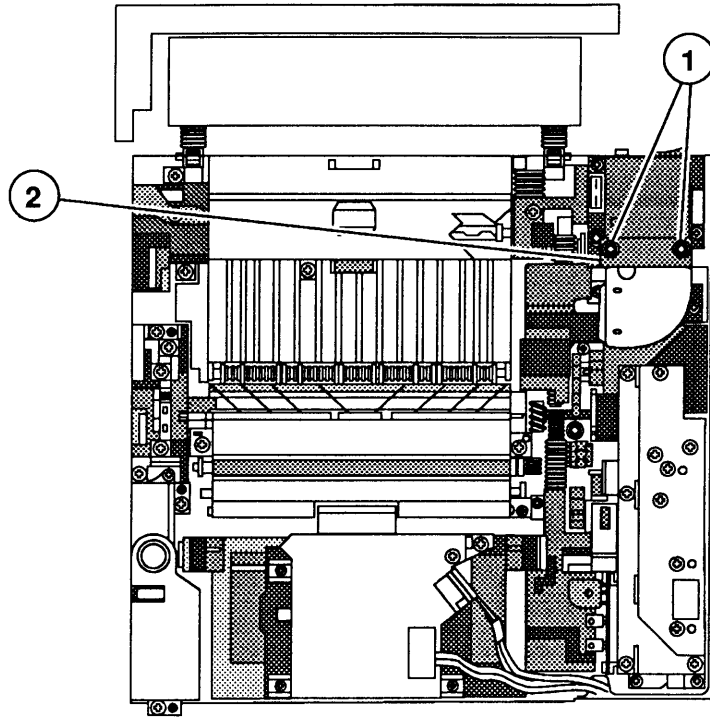

FIGURE 28

2. If the ozone filter case has an access door (Figure 28, #2), open the access door and pull on the ozone filter tab to slide the filter out of the case.
3. If the filter case does not have an access door, remove the two Phillips screws (Figure 28, #1) that secure the filter case to the power supply block, and remove the filter case.
4. Slide the ozone filter down and out of the filter case.

Replace

1. Slide the ozone filter into the filter case.

CAUTION: *Be careful when handling the ozone filter. It is brittle and can break if handled roughly.*

2. Place the filter case in position, and replace the two Phillips screws.
3. Replace the cover set.

□ LASER/SCANNER ASSEMBLY

Remove

1. Remove the cover set.

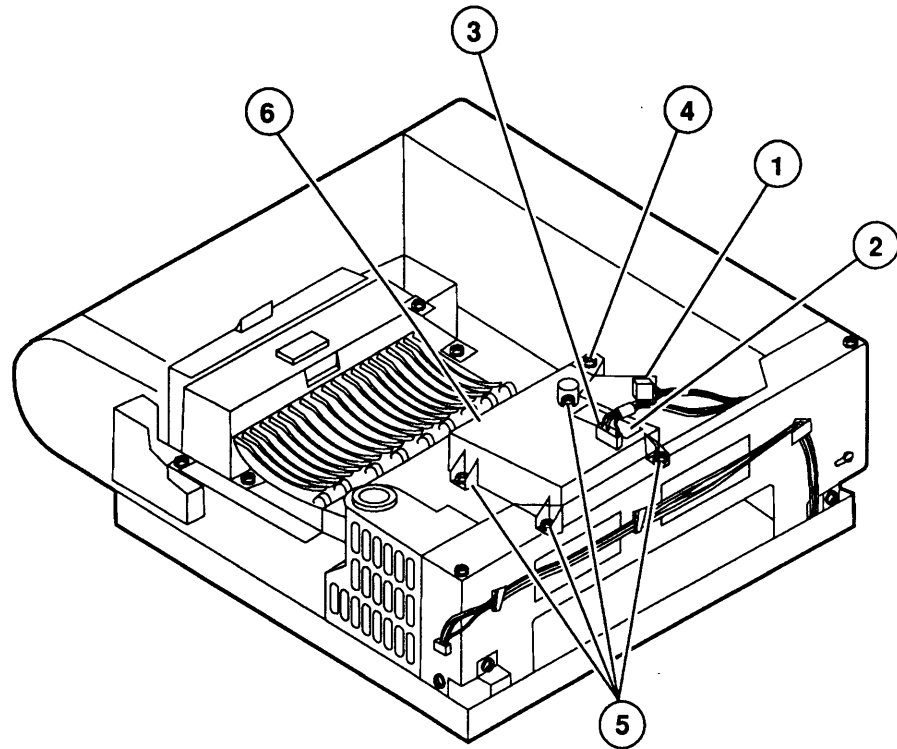

FIGURE 29

2. Disconnect the laser diode cable (Figure 29, #1) from laser diode PCA connector J451.
3. Open the scanning motor PCA cover (Figure 29, #2) and disconnect the scanning motor cable (Figure 29, #3) from scanning motor PCA connector J401.
4. Remove the Phillips screw (Figure 29, #4) on the optical fiber cover and open the cover.
5. **Carefully** slide the optical fiber up and out of the laser/scanner assembly.
6. Remove the four Phillips screws (Figure 29, #5) securing the laser/scanner assembly (Figure 29, #6) to the cassette holder. Remove the scanner unit.

Replace

1. Place the laser/scanner assembly in position and replace the four Phillips screws.
2. Connect the 4-pin laser diode cable to laser diode PCA connector J451.
3. Connect the 5-pin scanning motor cable to scanning motor PCA connector J401. Close the scanning motor PCA cover.

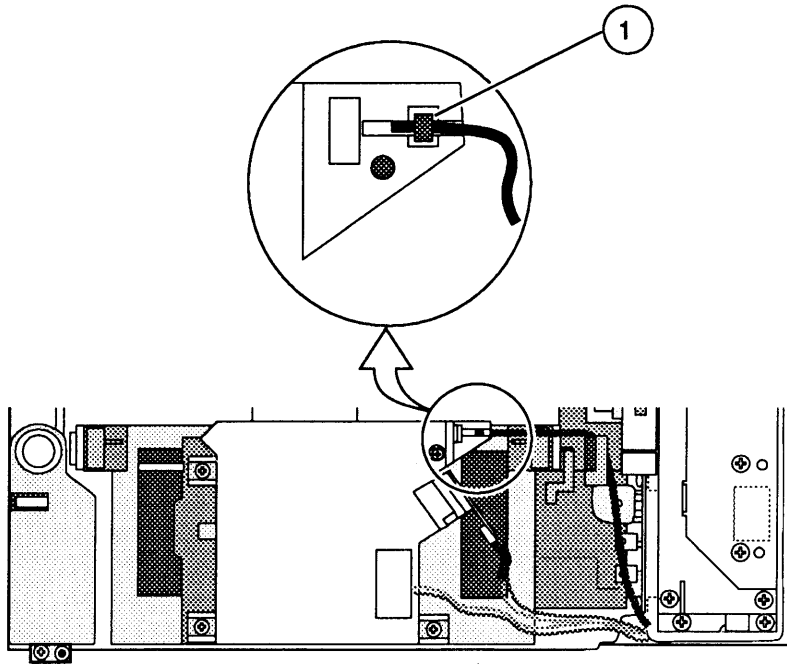

FIGURE 30

4. Place the metal "doughnut" (Figure 30, #1) on the optical fiber in its slot in the laser/scanner assembly.
5. Close the optical fiber cover and replace the Phillips screw.
6. Replace the cover set.

□ HIGH-VOLTAGE POWER SUPPLY ASSEMBLY

Materials Required

Small, flat-blade screwdriver
#2 Phillips screwdriver

Remove

1. Remove the cover set.

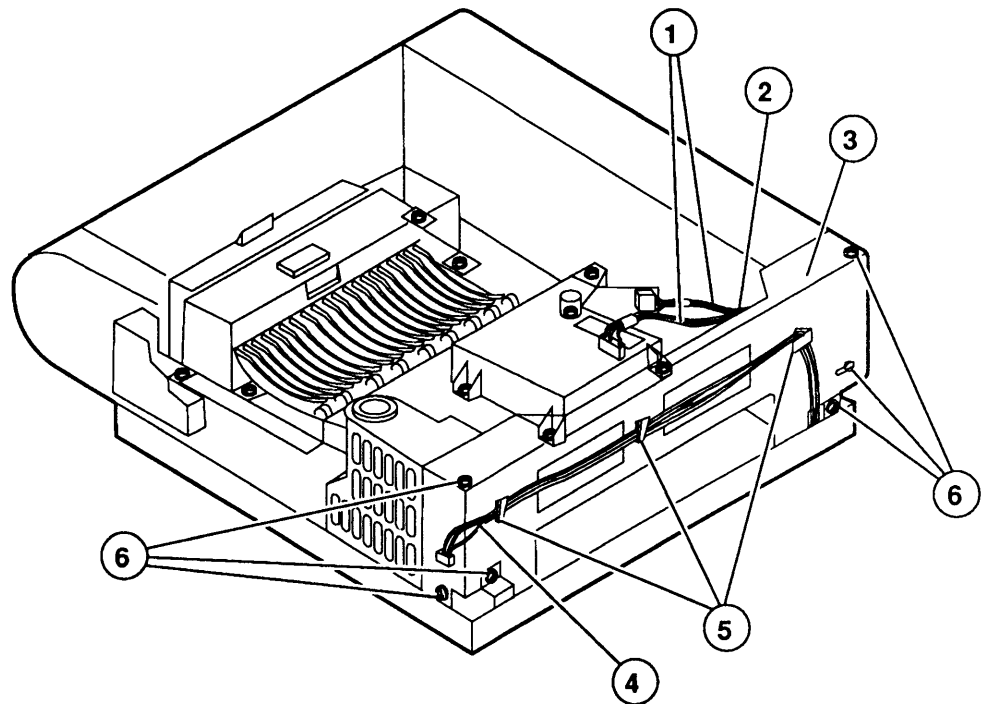

FIGURE 31

2. Remove the laser/scanner cables (Figure 31, #1) from the cable clip (Figure 31, #2) behind the right support plate (Figure 31, #3).
3. Remove the status panel cables (Figure 31, #4) from the three cable clips (Figure 31, #5) on the right support plate (Figure 31, 3).
4. Remove the six Phillips screws (Figure 31, #6) that secure the right support plate to the chassis, and rest the plate on the work surface next to the printer.

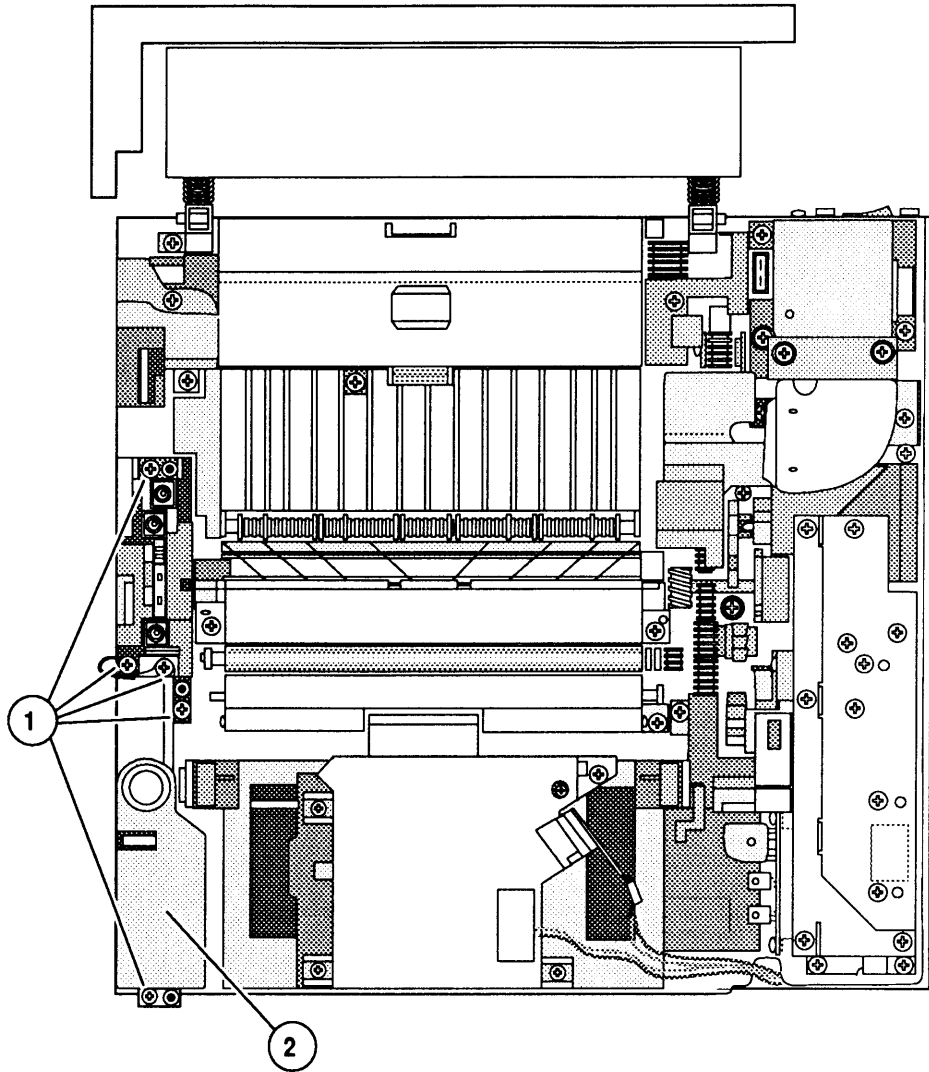

FIGURE 32

5. Remove the four Phillips screws (Figure 32, #1) that secure the high-voltage power supply assembly (Figure 32, #2) to the cassette holder.
6. Lift the high-voltage power supply straight up and remove it from the printer.

Replace

Note: Before testing the printer after replacing the high-voltage power supply, be sure to install the four Phillips screws (step 2). Failure to do so could cause erratic results due to poor electrical connections.

1. Place the high-voltage power supply in position, making sure to align the positioning pins as you do.

Note: Be sure the 8-pin connector on the bottom of the high-voltage power supply mates properly with its receptacle.

2. Replace the high-voltage power supply screws. Use the silver-colored Phillips screw at the left side of the high-voltage connector assembly. Refer to Figure 32 if necessary.
3. Place the right support plate in position and replace the six Phillips screws. Refer to Figure 31 if necessary.
4. Replace the laser/scanner cables in the cable clip behind the right support plate. Refer to Figure 31 if necessary.
5. Replace the status panel cables in the three cable clips on the right support plate. Refer to Figure 31 if necessary.
6. Replace the cover set.

□ DC POWER SUPPLY

Materials Required

#2 Phillips screwdriver

Remove

1. Remove the cover set.

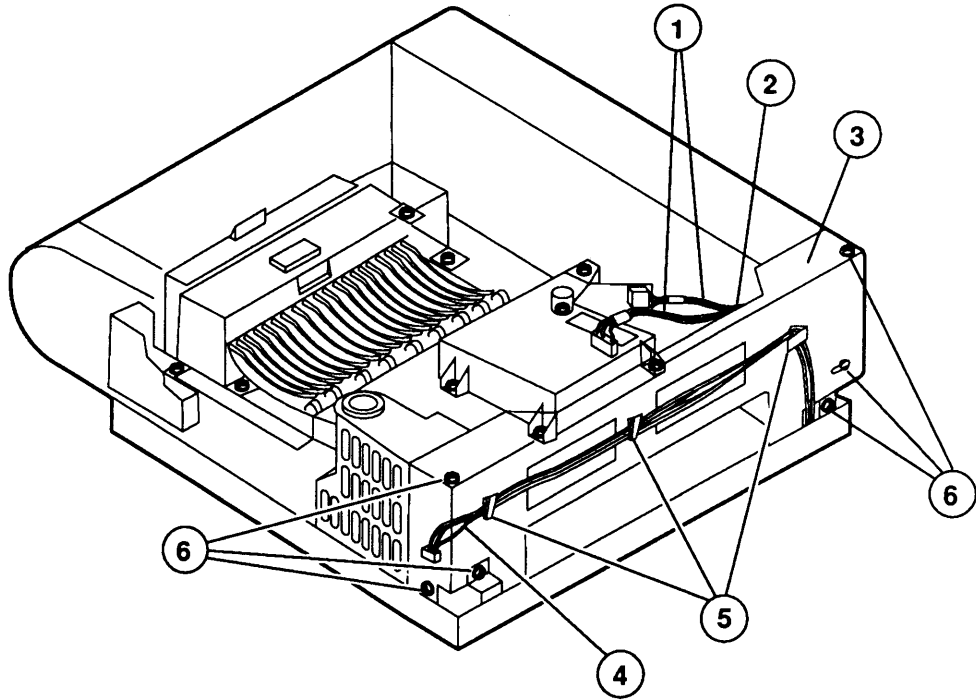

FIGURE 33

2. Remove the laser/scanner cables (Figure 33, #1) from the cable clip (Figure 33, #2) behind the right support plate (Figure 33, #3).
3. Remove the status panel cables (Figure 33, #4) from the three cable clips (Figure 33, #5) on the right support plate (Figure 33, #3).
4. Remove the six Phillips screws (Figure 33, #6) that secure the right support plate to the chassis, and rest the plate on the work surface next to the printer.
5. Disconnect the main motor cable (Figure 34, #1) from DC power supply connector J3.

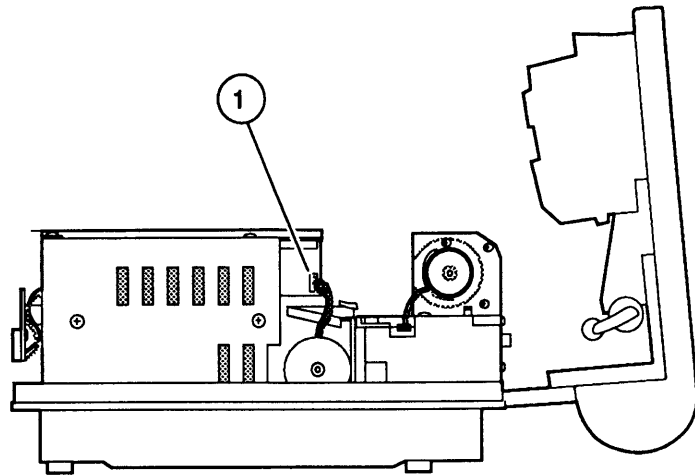

FIGURE 34

6. Remove the three Phillips screws (Figure 35, #1) that secure the DC power supply (Figure 35, #2) to the chassis.
7. Remove the optical fiber (Figure 35, #3) from its holder (Figure 35, #4) on the distribution cover.

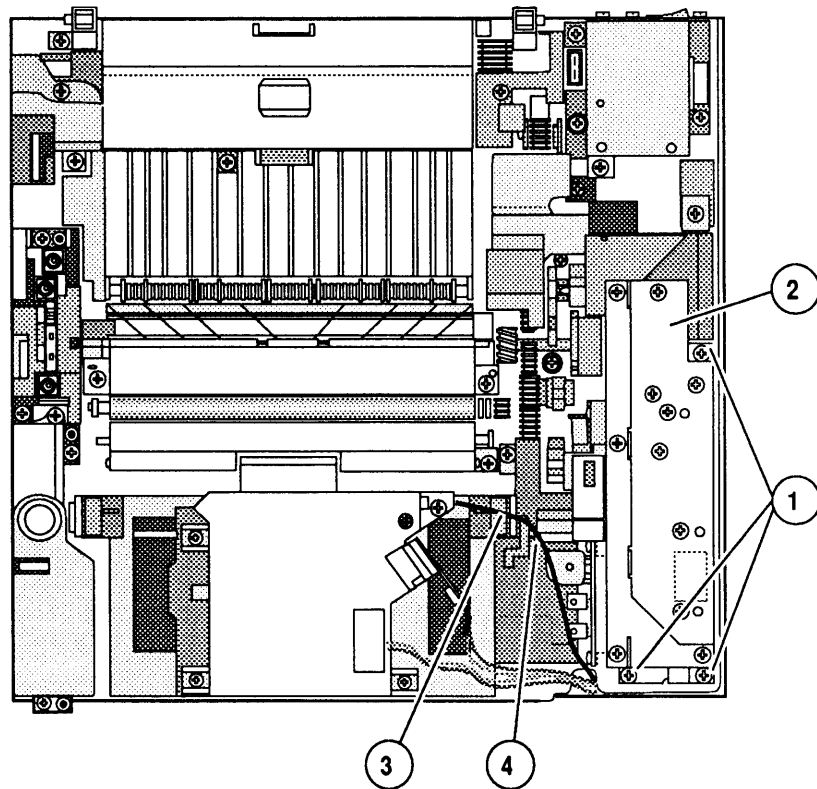

FIGURE 35

8. Lift the DC power supply straight up and remove it from the printer.

Note: Removing the power supply may require quite a bit of force, but don't worry: you won't damage anything.

9. If you are returning the DC power supply to Apple, be sure to first remove the distribution PCA and cover.

Replace

Note: Before testing the printer after installing the DC Power Supply, be sure to install the three power supply screws (step 2). Failure to do so could result in erratic results due to poor electrical connections.

1. Place the DC power supply in position and make sure to align the positioning pins and the connector pins as you do.
2. Replace the three DC power supply screws. The screw with the star washer should be used at the left side of the power supply. Refer to Figure 35 if necessary.
3. Place the optical fiber in its holder. Refer to Figure 35.
4. Connect the main motor cable to DC power supply connector J3. Refer to Figure 34.
5. Place the right support plate in position and replace the six Phillips screws. Refer to Figure 33.
6. Replace the laser/scanner cables in the cable clip behind the right support plate. Refer to Figure 33.
7. Replace the status panel cables in the three cable clips on the right support plate. Refer to Figure 33.
8. Replace the cover set.

□ DISTRIBUTION PCA

Remove

1. Remove the cover set and DC power supply.

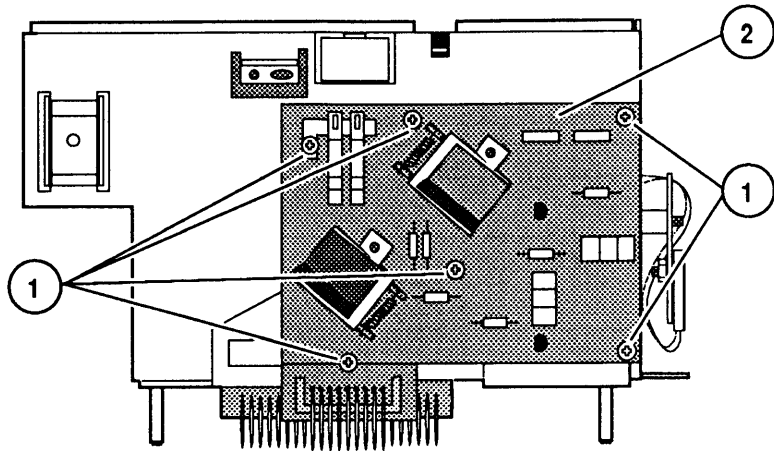

FIGURE 36

2. Remove the Phillips screw (Figure 36, #1) that secures the distribution cover (Figure 36, #2) to the DC power supply. Remove the cover.

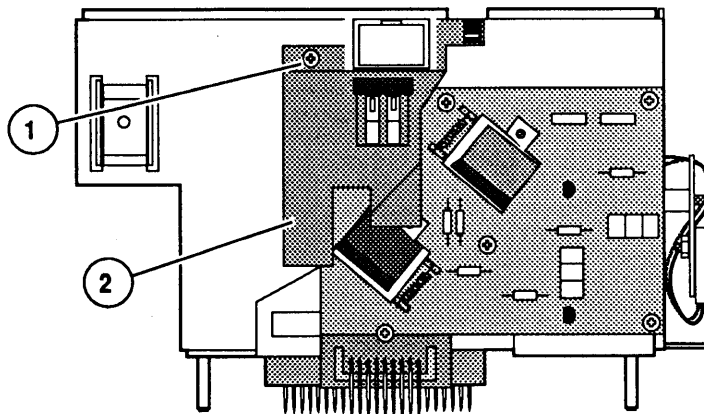

FIGURE 37

3. Remove the six Phillips screws (Figure 37, #1) that secure the distribution PCA (Figure 37, #2) to the DC power supply. Remove the distribution PCA.

Replace

1. Place the distribution PCA into position on the DC power supply and replace the six distribution PCA screws.

2. Place the distribution cover in position and replace the Phillips screw. Be sure the tab at the bottom of the distribution cover goes behind the distribution PCA.
3. Replace the DC power supply and cover set.

□ MAIN MOTOR ASSEMBLY

Remove

1. Remove the cover set, fuser assembly, DC power supply, and power supply block.

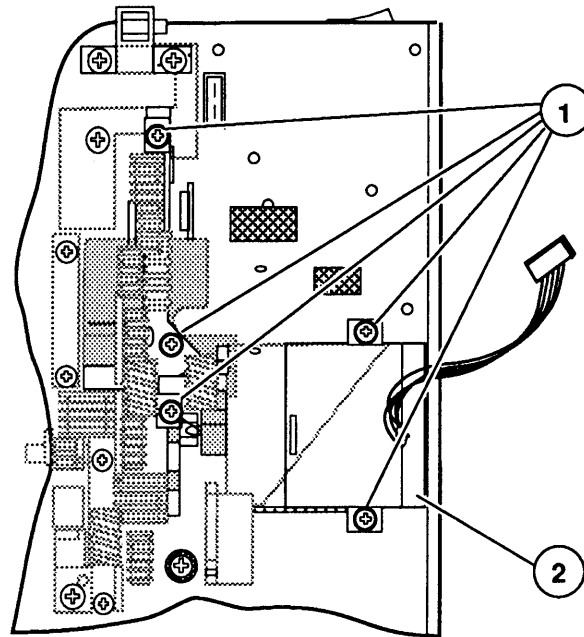

FIGURE 38

2. Remove the five screws (Figure 38, #1) securing the main motor assembly (Figure 38, 2) to the chassis.
3. Lift the main motor assembly straight up and remove it from the printer.

Replace

1. Place the main motor assembly in position. Make sure the positioning pins sticking up from the chassis engage in their corresponding holes in the motor bracket.
2. Replace the five main motor assembly screws.
3. Replace the power supply block, DC power supply, fuser assembly, and the cover set.

□ DRIVE GEAR ASSEMBLY

Remove

1. Remove the cover set, fuser assembly, DC power supply, and main motor assembly.

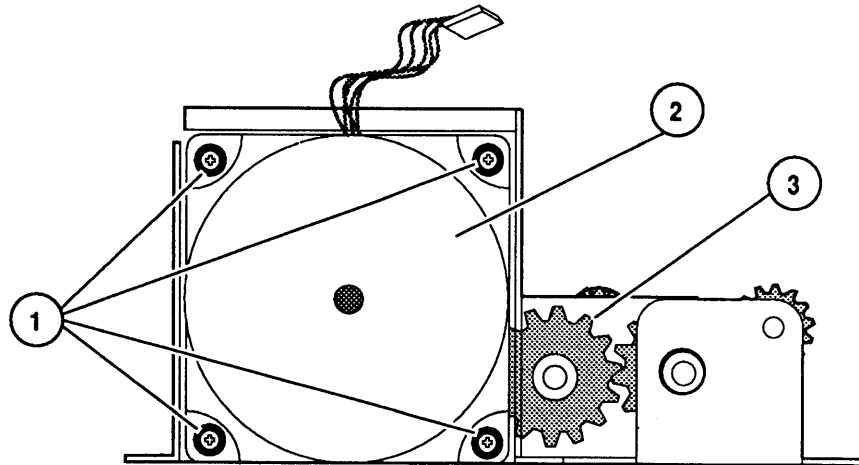

FIGURE 39

2. Remove the four Phillips screws (Figure 39, #1) that secure the main motor (Figure 39, #2) to the drive gear assembly (Figure 39, #3). Remove the main motor.

Replace

1. Place the main motor in position on the drive gear assembly and replace the four Phillips screws.
2. Replace the main motor assembly, DC power supply, fuser assembly, and cover set.

□ TRANSFER GUIDE ASSEMBLY

Materials Required

#2 Phillips screwdriver

Remove

1. Depress the release button and open the top cover.

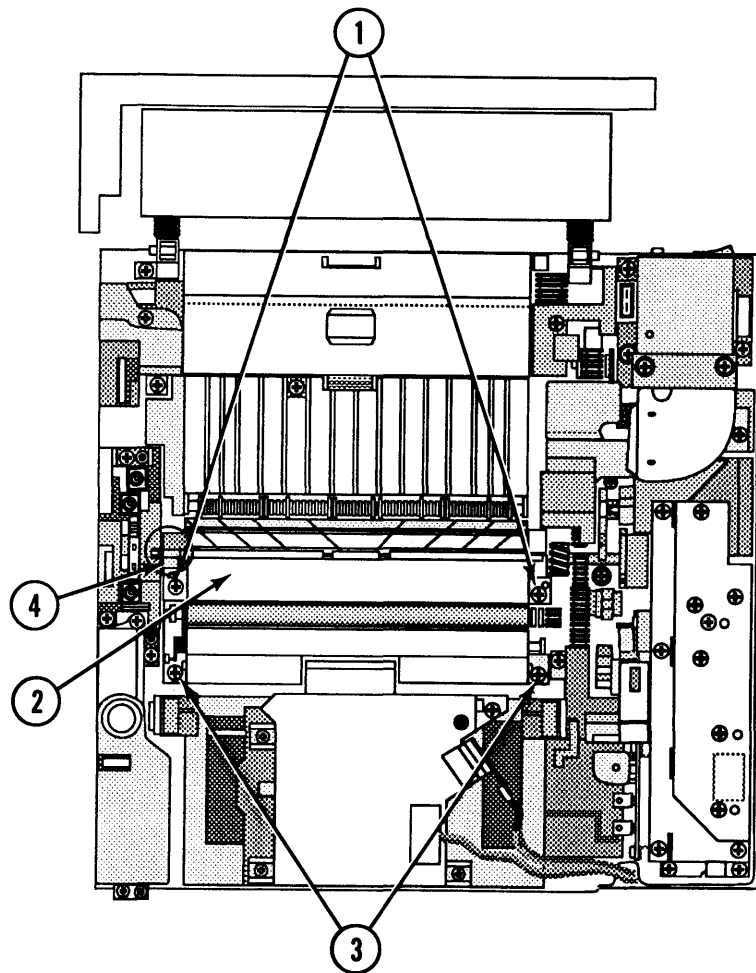

FIGURE 40

2. Remove the two Phillips screws (Figure 40, #1) that secure the upper transfer guide (Figure 40, #2) to the transfer guide assembly.
3. Remove the two Phillips screws (Figure 40, #3) that secure the transfer guide assembly to the cassette holder.
4. Lift the transfer guide assembly from the printer.

Replace

1. Make sure the collar at the end of the roller shaft is positioned as shown in Figure 40, #4. Place the transfer guide assembly in position.
2. Replace the two transfer guide assembly screws.
3. Place the upper transfer guide in position and replace the two screws.

□ SEPARATION PAD

Materials Required

#2 Phillips screwdriver

Remove

1. Remove the transfer guide assembly.

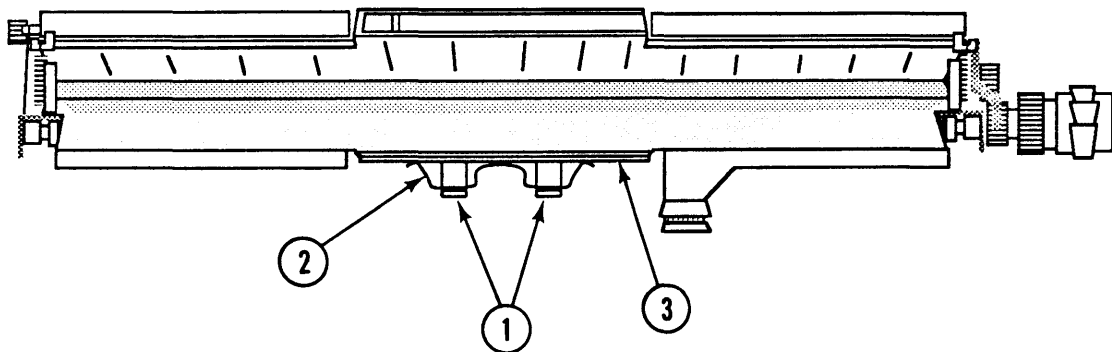

FIGURE 41

2. Remove the two Phillips screws (Figure 41, #1) that secure the leaf spring (Figure 41, #2) and separation pad (Figure 41, #3) to the lower paper guide.

Replace

1. Place the separation pad in place on the lower paper guide. The positioning pins will allow the pad to be placed only one way.
2. Place the leaf spring in position and replace the two Phillips screws.
3. Replace the transfer guide assembly.

□ TRANSFER CORONA ASSEMBLY

Remove

1. Remove the cover set, transfer guide assembly, and high voltage power supply.

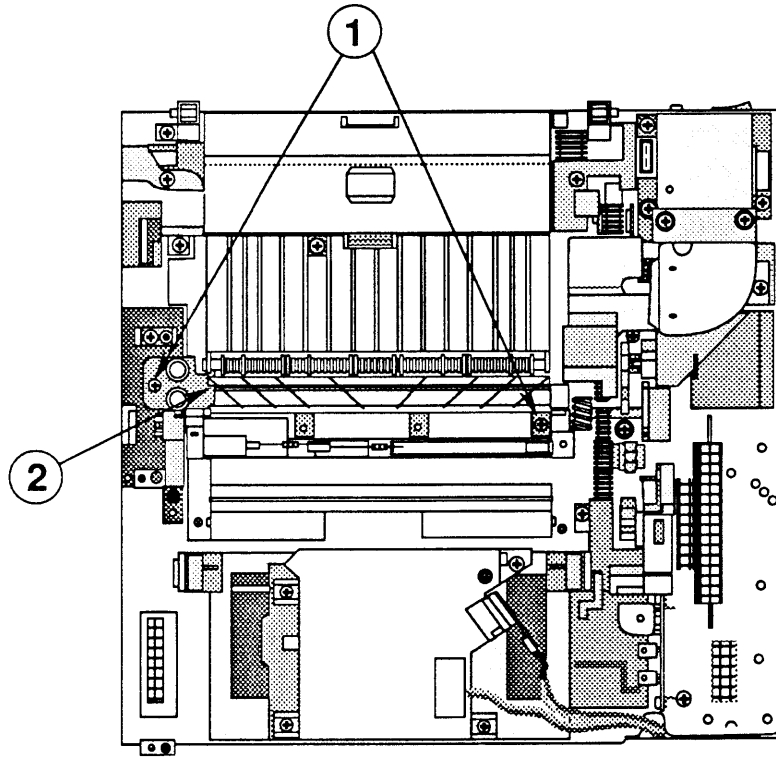

FIGURE 42

2. Remove the two Phillips screws (Figure 42, #1) that secure the transfer corona assembly (Figure 42, #2) to the chassis. Remove the transfer corona assembly.

Note: To shorten this procedure, remove the transfer guide assembly, remove three of the screws that secure the high voltage power supply (refer to Figure 32), and lift the power supply up and to the side. Then remove the two screws holding the transfer corona assembly in place.

Replace

1. Place the transfer corona assembly in position and replace the two Phillips screws.
2. Replace the high voltage power supply, transfer guide assembly, and cover set.

□ RESTRING CORONA WIRE

Materials Required

#2 Phillips screwdriver
Corona wire
Nylon guide wire
Spring hook (if the present one is damaged or broken)
Needlenose pliers
Diagonal cutters

Remove

1. Remove the cover set, transfer guide assembly, high voltage power supply, and transfer corona assembly.
2. Place the corona assembly in front of you so that the corona terminal is on the right side.

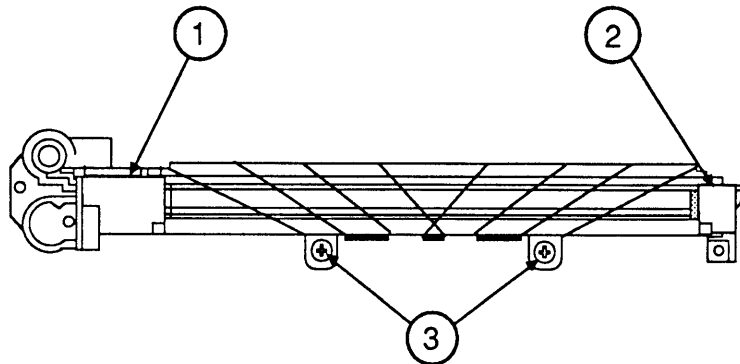

FIGURE 43

3. Remove both the corona wire termination covers (Figure 43, #1 and #2) by unsnapping them and lifting them clear of the assembly.
4. Remove the tension spring from the end of the corona wire and set it aside.
5. Remove the nylon guide wire by loosening the screws (Figure 43, #3) that hold it to the corona assembly.
6. Remove the corona wire.

Replace

1. Take the new corona wire, fold back approximately a 1/4" length, and make six to eight half-turns to form a loop at the end of the wire.

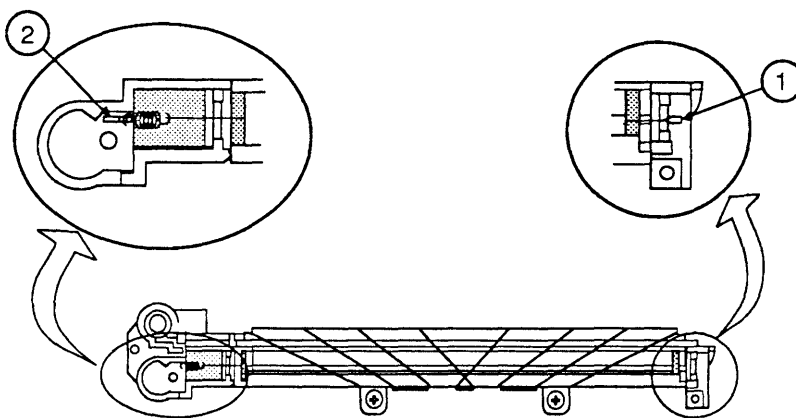

FIGURE 44

2. Hook the loop over the plastic retaining pin (Figure 44, #1) at the right end of the assembly.
3. Stretch the wire across the length of the corona assembly until it reaches the corona wire terminal (Figure 44, #2).
4. Using the same procedure as in step 1 above, form a loop at the end of the corona wire.
5. Hook one end of the tension spring onto the loop and the other end onto the corona wire terminal. The wire should be clean, have no kinks, and be taut enough to remain straight.
6. Replace the corona wire termination covers.
7. Restring the guide wire as shown in Figure 45:
 - a) Fasten one end of the guide wire with screw A.
 - b) Wind the wire tightly around the corona assembly as shown in Figure 45, and fasten the other end of the wire with screw B.

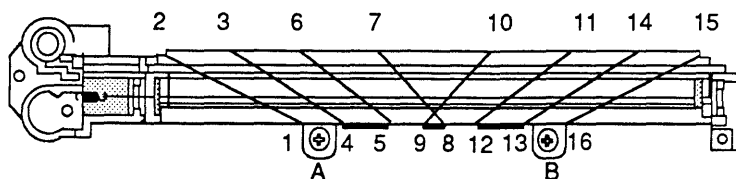

FIGURE 45

8. Replace the transfer corona assembly, high voltage power supply, transfer guide assembly, and cover set.

□ PAPER FEED ASSEMBLY

Materials Required

#2 Phillips screwdriver

Remove

1. Remove the cover set and DC power supply.

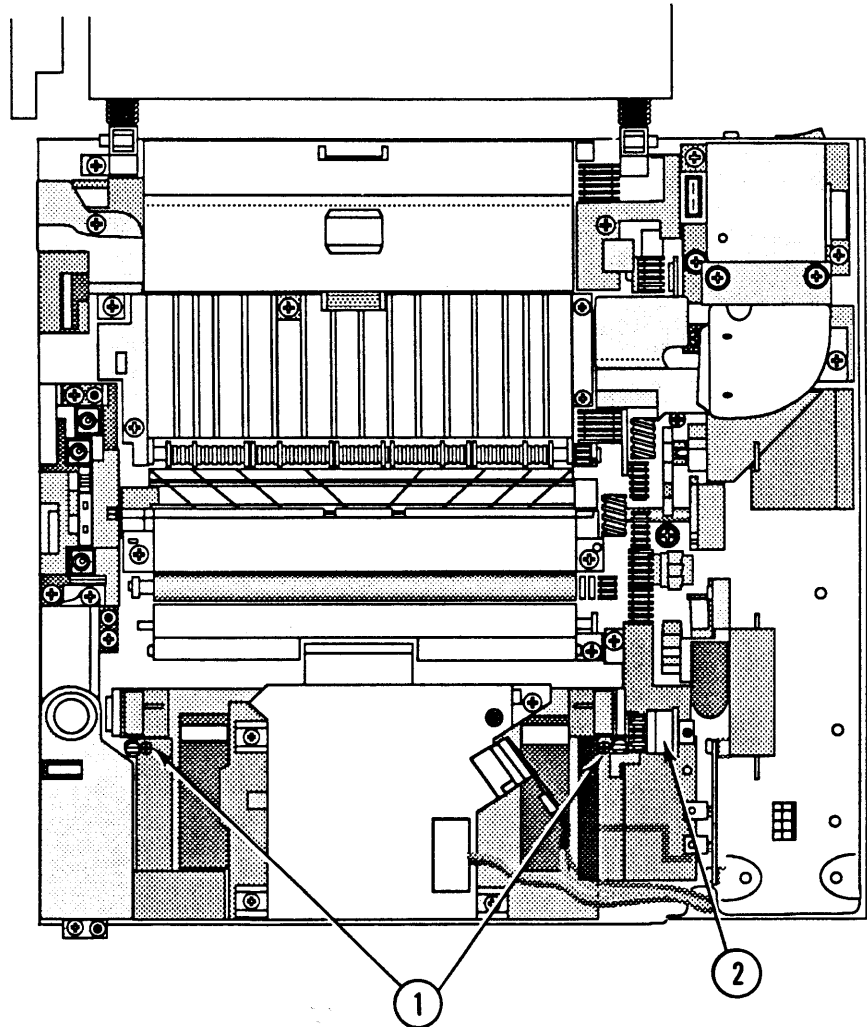

FIGURE 46

2. Remove the two Phillips screws (Figure 46, #1) that secure the paper feed assembly (Figure 46, #2) to the main body block.
3. Remove the paper feed assembly by moving it out of the main body block. Move the assembly toward the rear of the printer, where the DC power supply was.

Replace

1. Place the paper feed assembly in position in the main body block.
2. Replace the two paper feed assembly screws.
3. Replace the DC power supply and cover set.

□ PICKUP ROLLER

Materials Required

Small flatblade screwdriver

Remove

1. Remove the cover set, DC power supply, and paper feed assembly.

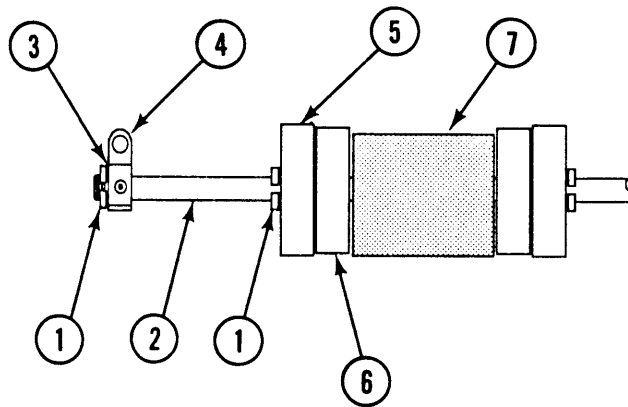

FIGURE 47

2. Using the small screwdriver, remove the two pickup roller C-rings (Figure 47, #1).
3. Remove the following items from the paper feed roller shaft (Figure 47, #2):
 - washer (Figure 47, #3)
 - bearing (Figure 47, #4)
 - roller (Figure 47, #5)
 - cam (Figure 47, #6)
 - pickup roller (Figure 47, #7)

Replace

Be sure to clean the pickup roller, two rollers, and the two cams **prior** to replacing the paper feed assembly. Failure to do so could cause stains on printed pages.

1. Place the following items, in order, on the paper feed roller shaft:

Note: When installing the pickup roller and cam, be sure to align the flat portions of each part on the same side.

- pickup roller (Figure 47, #7)
 - cam (Figure 47, #6)
 - roller (Figure 47, #5)
 - bearing (Figure 47, #4)
 - washer (Figure 47, #3)
2. Replace the two pickup roller C-rings (Figure 47, #1).
 3. Replace the paper feed assembly, DC power supply, and cover set.

□ PAPER FEED DRIVE ASSEMBLY

Materials Required

#2 Phillips screwdriver
Small, flatblade screwdriver

Remove

1. Remove the cover set, DC power supply, transfer guide assembly, high voltage power supply, transfer corona assembly, fuser assembly, power supply block, and main motor assembly.

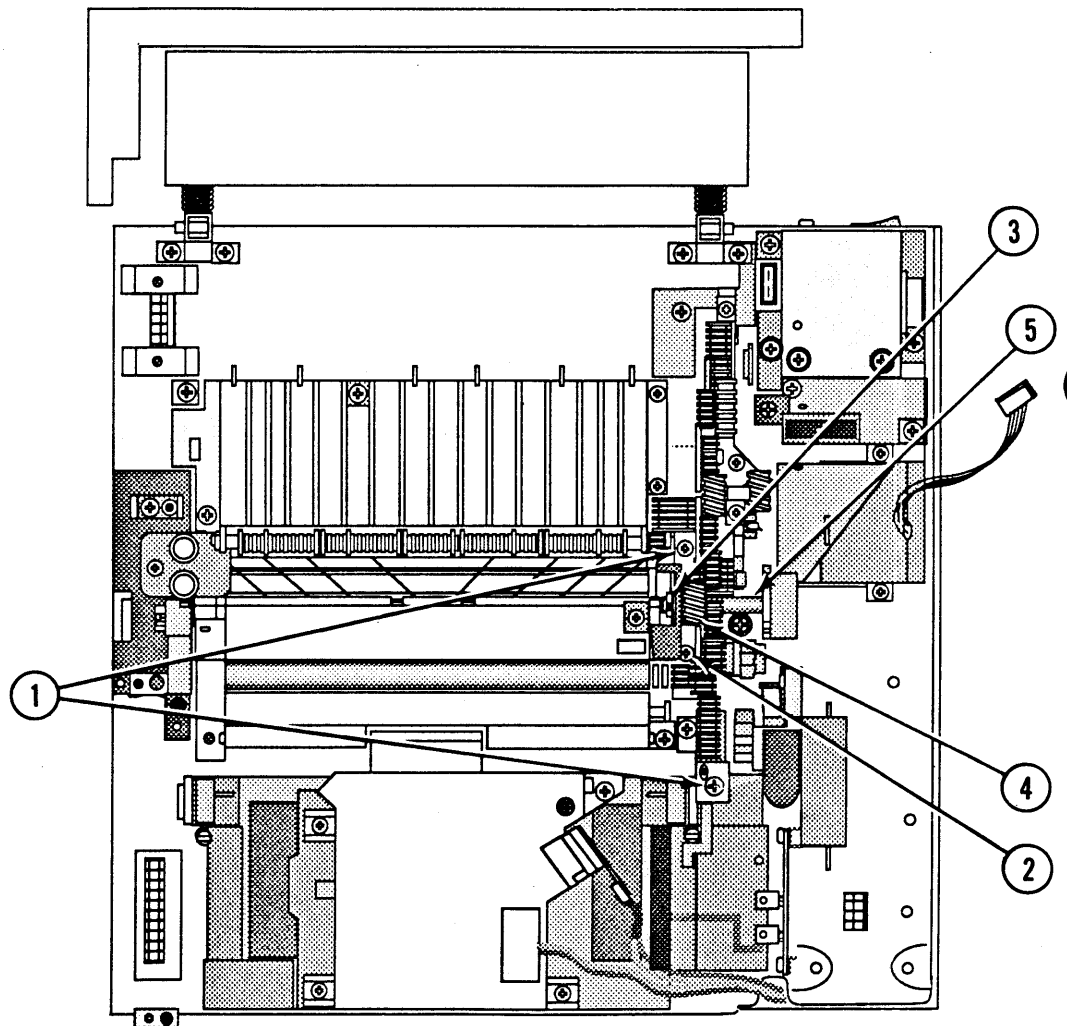

FIGURE 48

2. Remove the two Phillips self-tapping screws (Figure 48, #1) and the one Phillips machine screw (Figure 48, #2) that secure the paper feed drive assembly to the main body block.
3. Using the flatblade screwdriver, remove the C-ring (Figure 48, #3) that keeps the drum drive shaft in place.
4. Slide the drum drive shaft toward the rear of the printer. You need to align the pins on the shaft with the openings in the main body block.
5. Remove the paper pickup gear (Figure 48, #4) from the printer.
6. Remove the paper feed drive assembly from the printer.

Replace

1. Place the paper feed drive assembly in position and replace the three Phillips screws.
2. Place the paper pickup gear in position and slide the drum drive shaft into it. Be sure to align the pin in the shaft with the groove in the drive gear.
3. Slide the drum drive shaft into the bearing (Figure 48, #5) and replace the C-ring at the end of the shaft.
4. Replace the main motor assembly, power supply block, fuser assembly, transfer corona assembly, high voltage power supply, transfer guide assembly, DC power supply, and cover set.

□ FEEDER ASSEMBLY

Materials Required #2 Phillips screwdriver

Remove 1. Remove the fuser assembly.

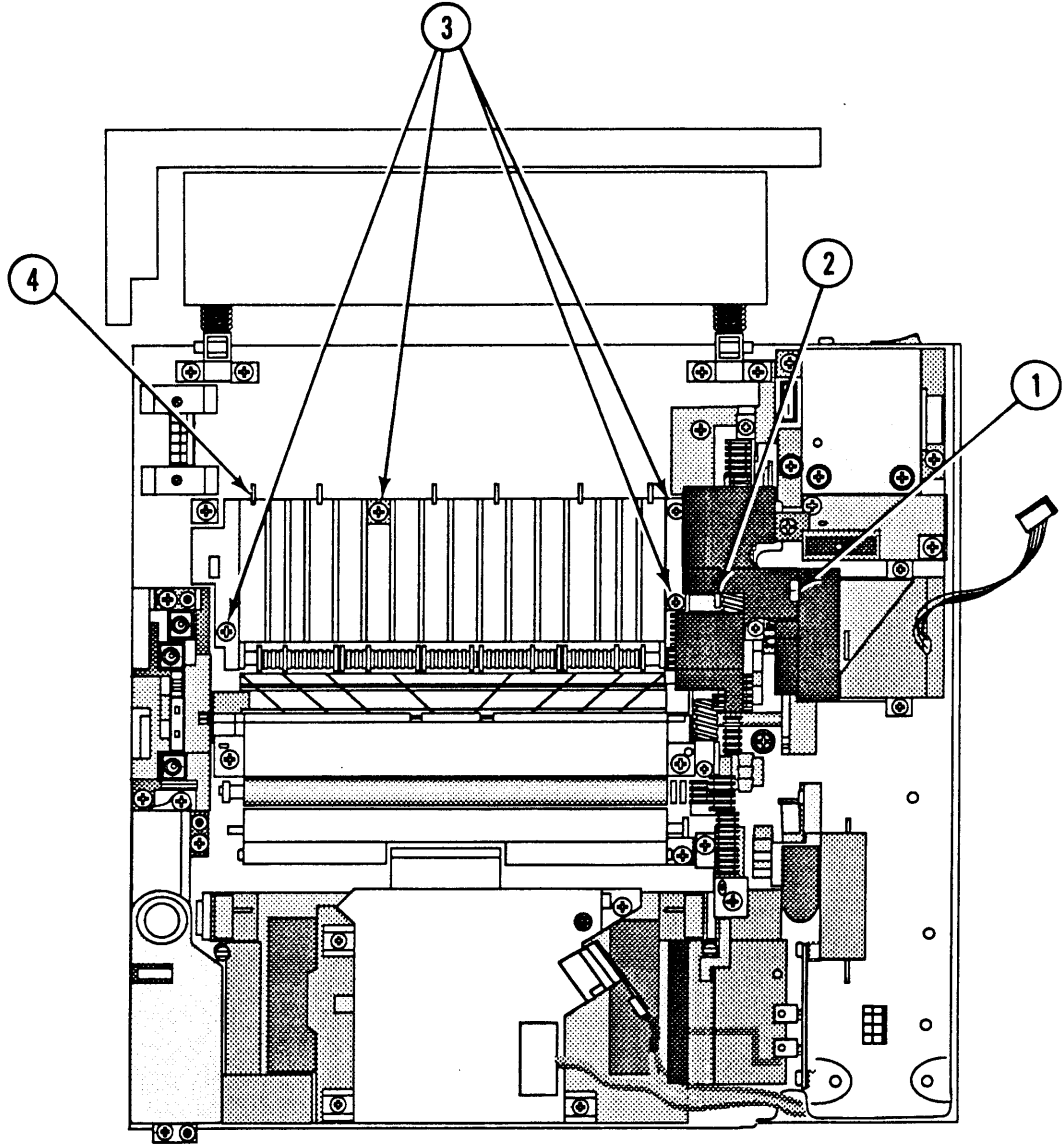

FIGURE 49

2. Remove the Phillips screw (Figure 49, #1) that secures the main motor drive assembly cover (Figure 49, #2) to the main motor mount. Remove the cover.
3. Remove the four Phillips screws (Figure 49, #3) that secure the feeder assembly (Figure 49, #4) to the chassis. Remove the feeder assembly.

Replace

1. Place the feeder assembly in position. Make sure to engage the tab at the front of the feeder in the slot in the main body block. The positioning pins should also be engaged in the corresponding holes in the feeder assembly.
2. Replace the four feeder assembly screws.
3. Place the main motor drive assembly cover in position and replace the Phillips screw.
4. Replace the fuser assembly.

□ FEEDER GUIDE GEAR (24 TOOTH)

Materials Required Small, flatblade screwdriver

Remove 1. Remove the cover set, fuser and feeder assemblies.

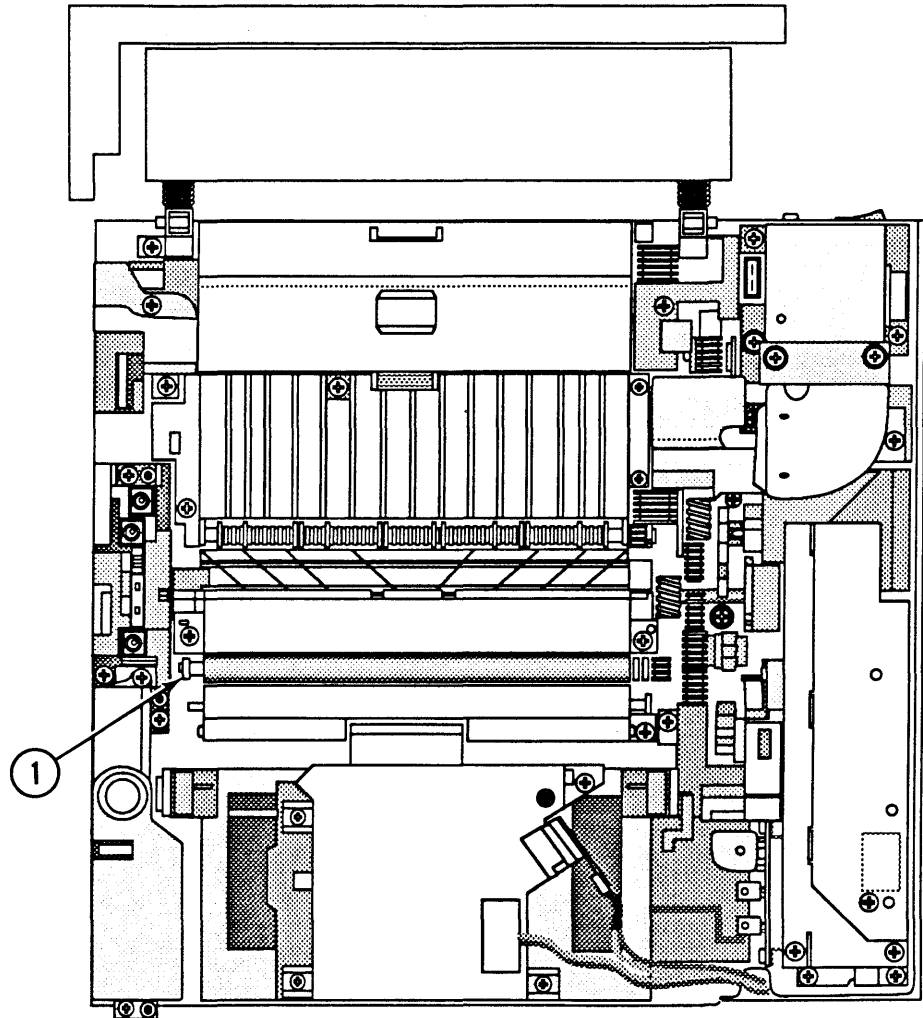

FIGURE 50

2. Using the screwdriver, remove the C-ring (Figure 50, #1) that secures the feeder guide gear to the separation roller shaft. Remove the feeder guide gear.

Replace

1. Place the feeder guide gear on the separation roller shaft.
2. Replace the feeder guide gear C-ring.
3. Replace the feeder and fuser assemblies and cover set.

□ PRESSURE ASSEMBLY

Materials Required

#2 Phillips screwdriver

Remove

1. Remove the cover set, fuser assembly, power supply block, DC power supply, main motor assembly, high voltage power supply assembly, and transfer guide assembly.

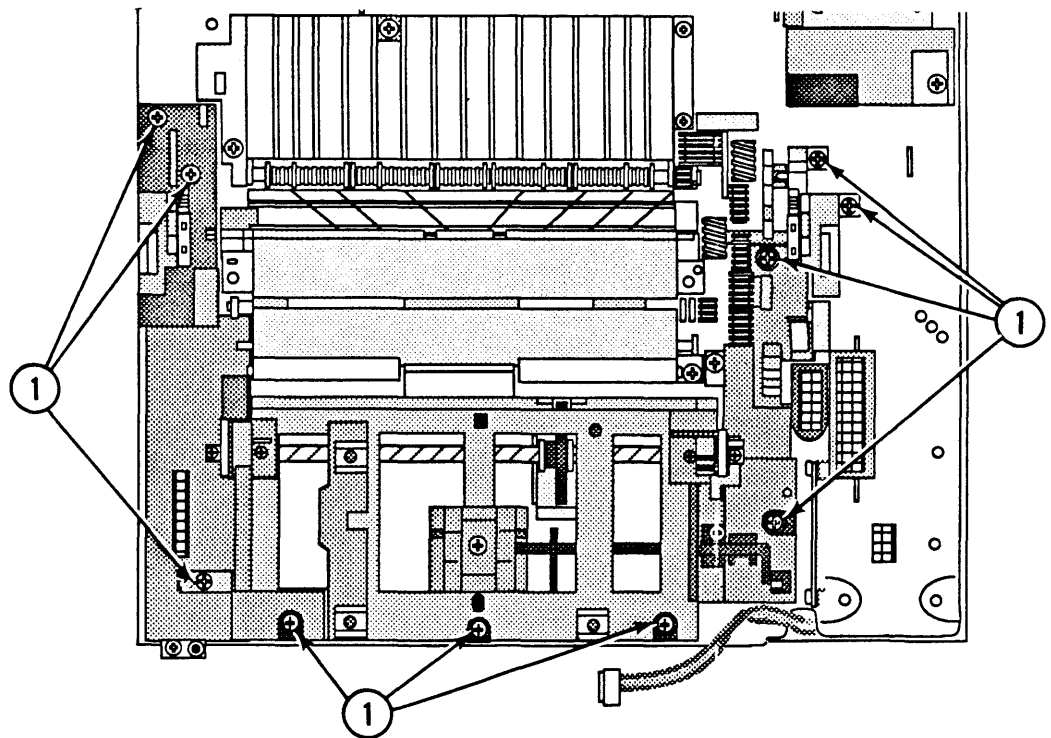

FIGURE 51

2. Remove the ten Phillips screws (Figure 51, #1) that secure the cassette holder to the chassis. Remove the cassette holder.

3. **Carefully** turn the cassette holder upside down.

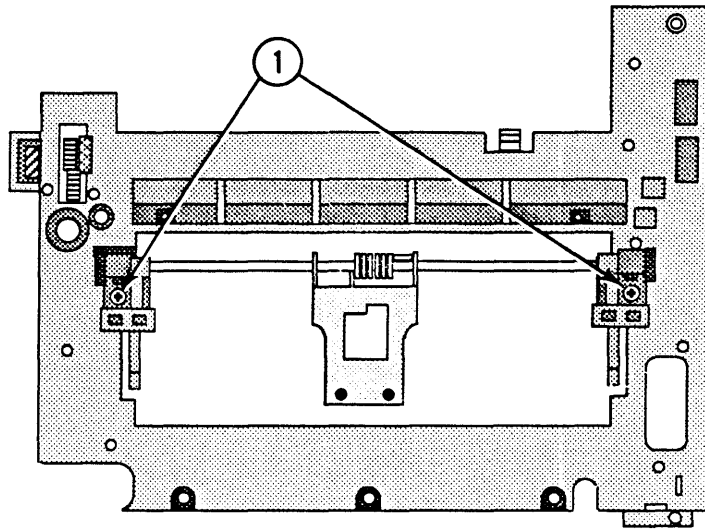

FIGURE 52

4. Remove the two Phillips screws (Figure 52, #1) that secure the pressure assembly to the cassette holder. Remove the pressure assembly.
5. Remove the left and right cassette stops from the pressure assembly.

Replace

1. Place the left and right cassette stops removed from the old pressure assembly on the new assembly.
2. Place the pressure assembly in position on the cassette holder. Replace the two Phillips screws.
3. Place the cassette holder in position on the chassis. Be sure the left and right cams and the cassette plate are pointing toward the outside of the printer.
4. Replace the nine cassette holder screws.
5. Replace the transfer guide assembly, high voltage power supply, main motor assembly, DC power supply, power supply block, fuser assembly, and cover set.

□ PAPER PICKUP GEAR (19 TOOTH)

Materials Required

Small, flatblade screwdriver

Remove

1. Open the top cover.

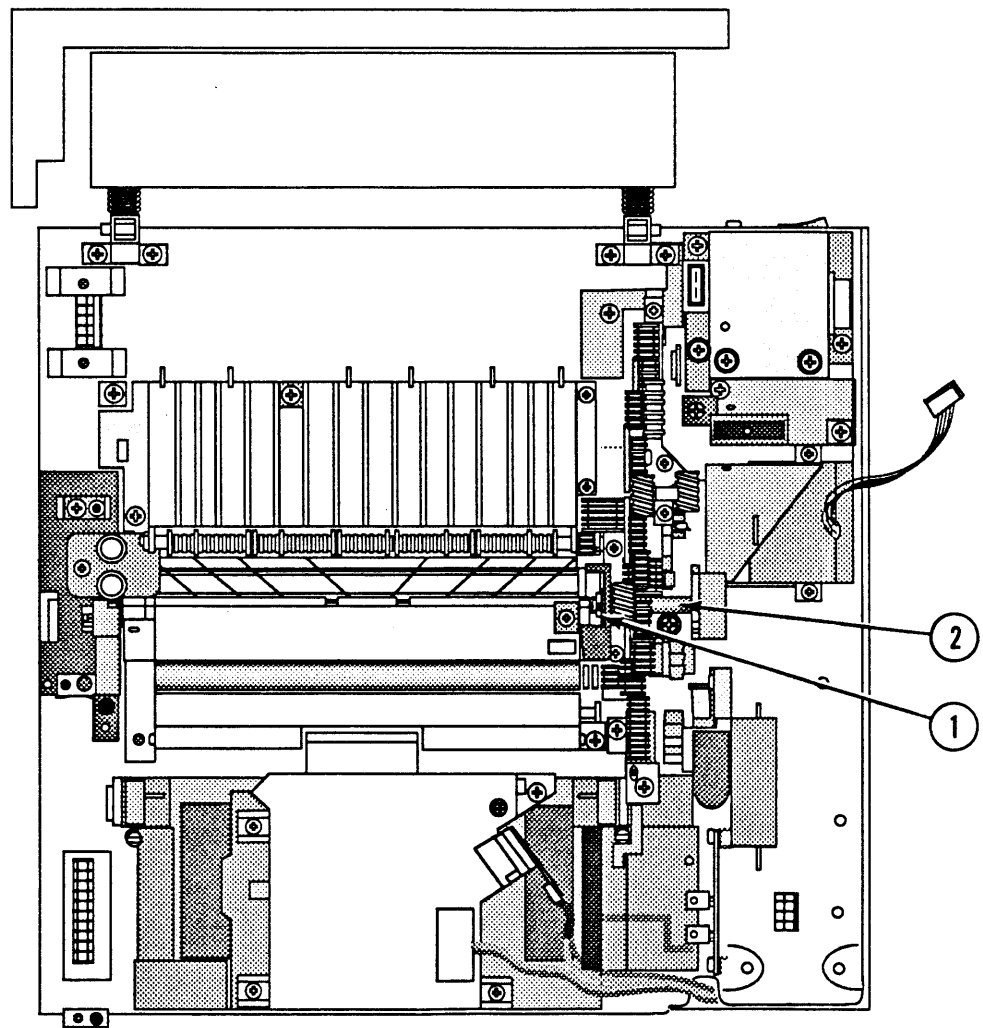

FIGURE 53

2. Using the flatblade screwdriver, remove the C-ring (Figure 53, #1) that keeps the drum drive shaft (Figure 53, #2) in place.

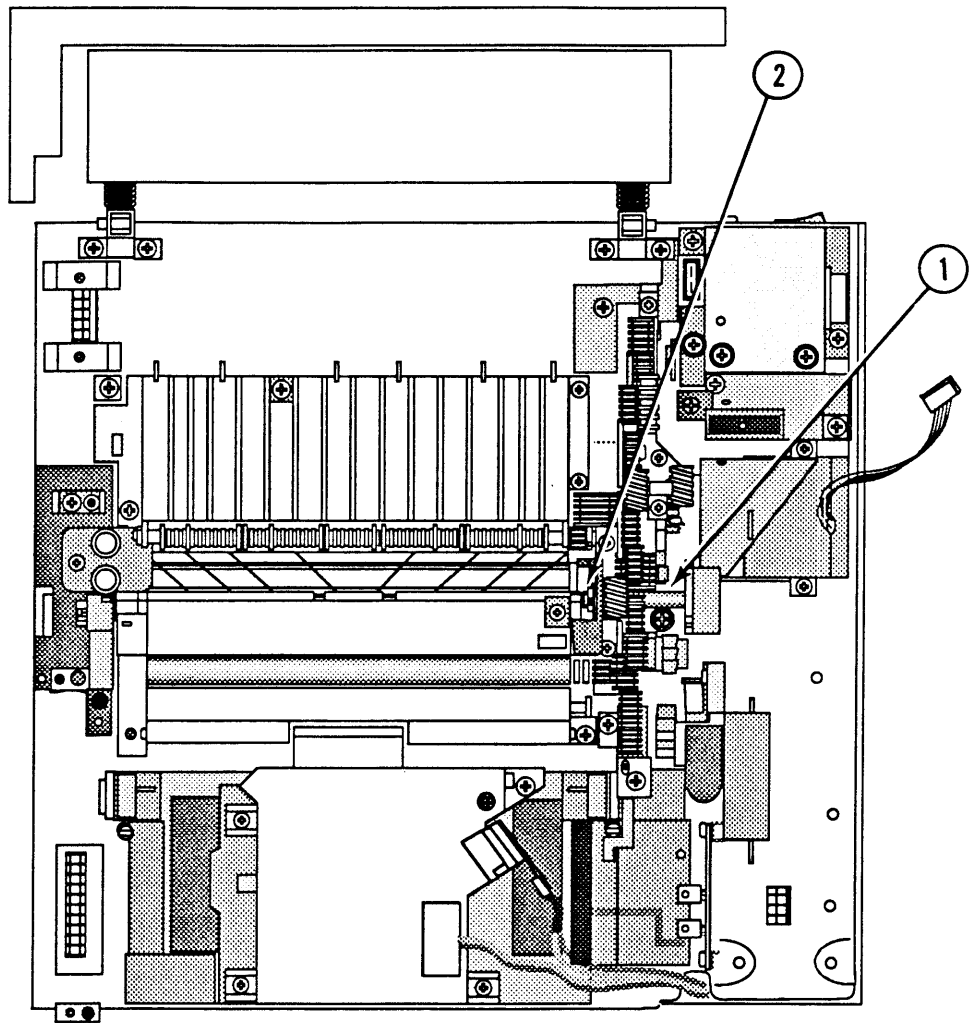

FIGURE 54

3. Slide the drum drive shaft (Figure 54, #1) toward the rear of the printer. You need to align the pins on the shaft with the openings in the cassette holder.
4. Remove the paper pickup gear.

Replace

1. Place the paper pickup gear in position and slide the drum drive shaft into it. Be sure to align the pin in the shaft with the groove in the gear.
2. Slide the drum drive shaft into the bearing (Figure 54, #2) and replace the C-ring at the end of the shaft.

□ PAPER PICKUP GEAR (57 TOOTH)

Materials Required

None

Remove

1. Remove the cover set, DC power supply, fuser assembly, power supply block, main motor assembly, and the 19-tooth paper pickup gear.
2. Remove the drum drive shaft out the rear of the cassette holder.
3. Remove the 57-tooth paper pickup gear.

Replace

1. Place the 57-tooth paper pickup gear in position in the cassette holder.
2. Slide the drum drive shaft first into its opening in the cassette holder and then into the pickup gear. Be sure to align the pin in the shaft with the groove in the gear.
3. Replace the 19-tooth paper pickup gear, main motor assembly, power supply block, fuser assembly, DC power supply, and cover set.

□ LEFT HOOK

Materials Required

#2 Phillips screwdriver

Remove

1. Remove the cover set and high voltage power supply assembly.

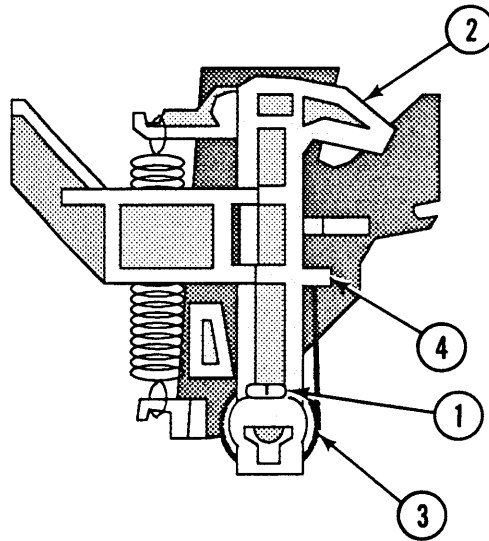

FIGURE 55

2. Remove the Phillips screw (Figure 55, #1) that secures the left hook (Figure 55, #2) to the hook shaft.
3. Slide the hook and torsion spring (Figure 55, #3) from the shaft to remove them.

Replace

1. Slide the hook onto the shaft and place the torsion spring behind the tab (Figure 55, #4) at the right side of the hook.
2. Replace the left hook screw.
3. Replace the high voltage power supply assembly and cover set.

□ LEFT LIFTER

Materials Required

None

Remove

1. Remove the cover set, high voltage power supply assembly, and left hook.

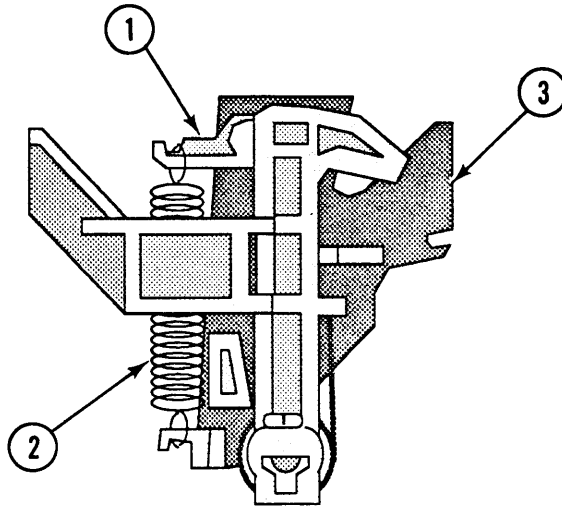

FIGURE 56

2. Remove the left lifter (Figure 56, #1) and tension spring (Figure 56, #2) from the left hook guide (Figure 56, #3).

Replace

1. Place the left lifter in position on the left hook guide.
2. Replace the tension spring between the lifter and guide.
3. Replace the left hook, high voltage power supply, and cover set.

□ LEFT HOOK GUIDE

Materials Required #2 Phillips screwdriver

Remove

1. Remove the cover set, high voltage power supply, left hook, and left lifter.

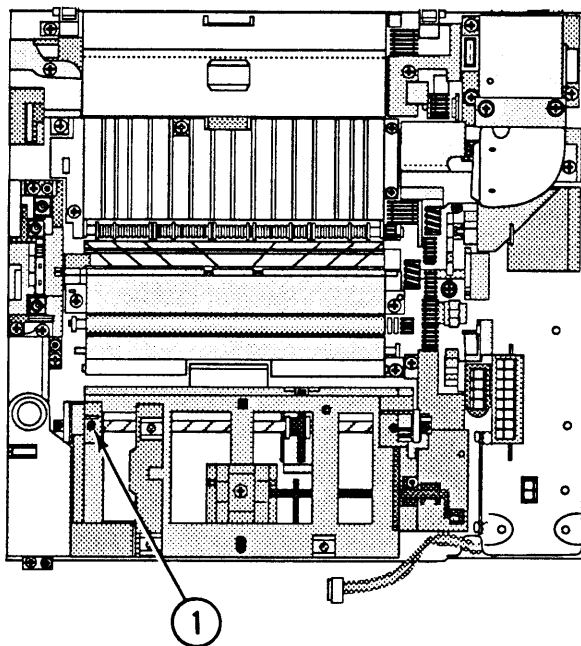

FIGURE 57

2. Remove the Phillips screw (Figure 57, #1) that secures the left hook guide to the main body block.
3. Slide the left hook guide off the hook shaft and remove the guide.

Replace

1. Slide the left hook guide onto the hook shaft and replace the Phillips screw. Be sure the guide is properly seated on its positioning pin.
2. Replace the left lifter, left hook, high voltage power supply, and cover set.

□ RIGHT HOOK

Materials Required

#2 Phillips screwdriver

Remove

1. Remove the cover set and DC power supply.

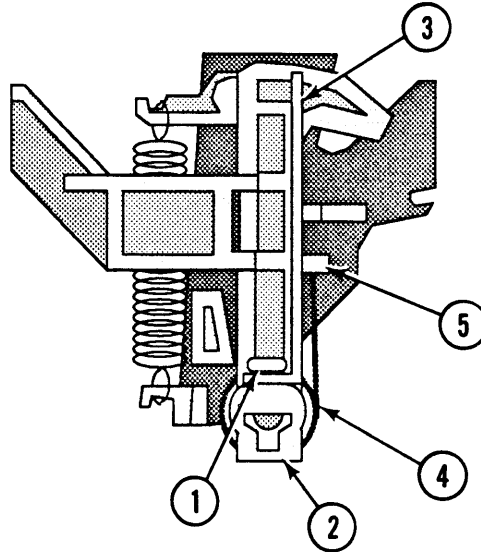

FIGURE 58

2. Remove the Phillips screw (Figure 58, #1) that secures the right hook (Figure 58, #2) and bracket (Figure 58, #3) to the hook shaft.
3. Slide the hook and torsion spring (Figure 58, #4) from the shaft to remove them.

Replace

1. Slide the hook onto the shaft and place the torsion spring behind the tab (Figure 58, #5) at the left side of the hook.
2. Replace the Phillips screw.
3. Replace the DC power supply and cover set.

□ RIGHT LIFTER

Materials Required None

Remove

1. Remove the cover set, DC power supply, and right hook.

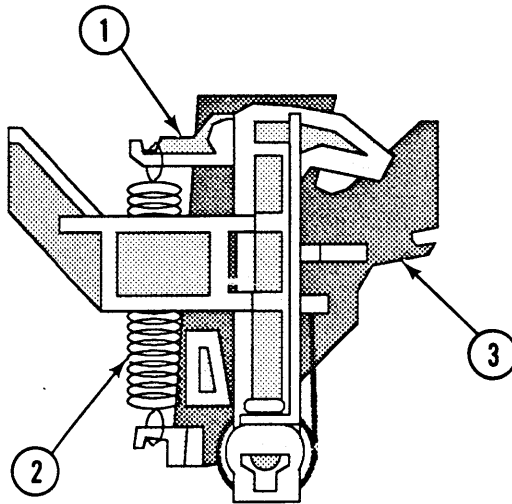

FIGURE 59

2. Remove the right lifter (Figure 59, #1) and tension spring (Figure 59, #2) from the right hook guide (Figure 59, #3).

Replace

1. Place the right lifter in position on the right hook guide.
2. Replace the tension spring between the lifter and guide.
3. Replace the right hook, DC power supply, and cover set.

□ RIGHT HOOK GUIDE

Materials Required

#2 Phillips screwdriver

Remove

1. Remove the cover set, DC power supply, right hook, and right lifter.

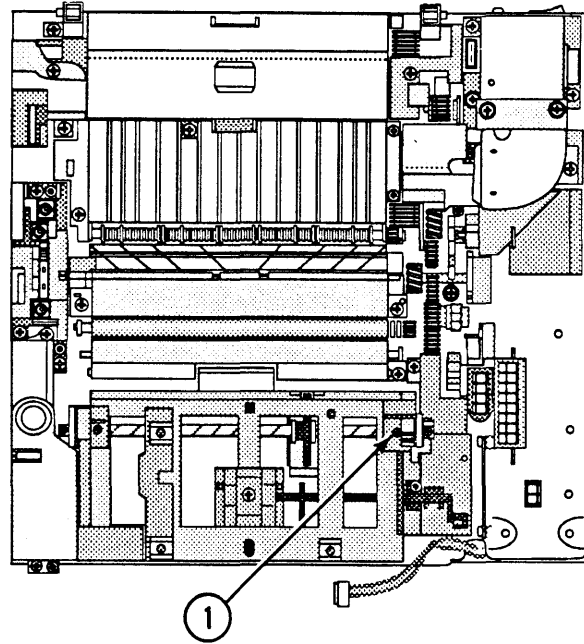

FIGURE 60

2. Remove the Phillips screw (Figure 60, #1) that secures the right hook guide to the main body block.
3. Slide the right hook guide off the hook shaft and remove the guide.

Replace

1. Slide the right hook guide onto the hook shaft and replace the Phillips screw. Be sure the guide is properly seated on its positioning pin.
2. Replace the right lifter, right hook, DC power supply, and cover set.

□ PAPER SENSING ARM

Materials Required None

Remove 1. Remove the cover set and DC power supply.

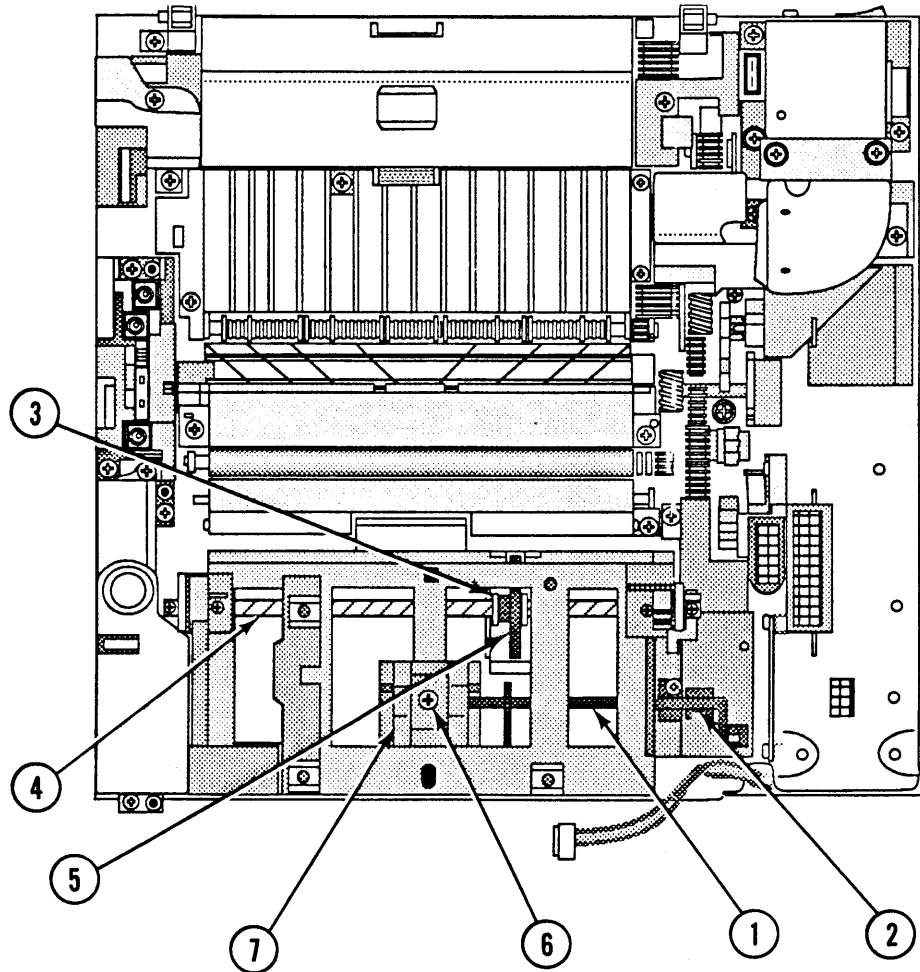

FIGURE 61

2. Carefully pull the paper sensing arm (Figure 61, #1) out of its clip on the cassette holder.
3. Slide the arm toward the rear of the printer and out of the cassette holder.

Replace

1. Slide the paper sensing arm into the cassette holder from the rear.
2. Place the arm in position. Note the position of the ends (Figure 61, #2) of the arm.
3. Replace the DC power supply and cover set.

□ AUXILIARY GUIDE

Materials Required

Small, flatblade screwdriver
#2 Phillips screwdriver

Remove

1. Remove the cover set, DC power supply, high voltage power supply, laser/scanner assembly, paper sensing arm, and left and right hooks, lifters, and hook guides.
2. Remove the shutter arm C-ring (Figure 61, #3) located toward the front of the printer.
3. Remove the hook shaft (Figure 61, #4) by sliding it out of the cassette holder toward the rear of the printer. Remove the shutter arm (Figure 61, #5).
4. Remove the Phillips screw (Figure 61, #6) that secures the auxiliary guide (Figure 61, #7) to the cassette holder. Remove the auxiliary guide.

Replace

1. Place the auxiliary guide in position and replace the Phillips screw.
2. Slide the hook shaft into position from the rear of the printer. The end of the shaft with the C-ring should be first into the printer.
3. Place the shutter arm in position and continue to slide the hook shaft through it and the cassette holder. Replace the shutter arm C-ring.
4. Replace the left and right hook guides, lifters, and hooks, paper sensing arm, laser/scanner assembly, high voltage power supply, DC power supply, and cover set.

□ CONTROLLER-I/O BOARD

Materials Required

#2 Phillips screwdriver

Remove

1. Loosen the two Phillips screws (Figure 62A) that secure the controller-I/O board to the chassis.

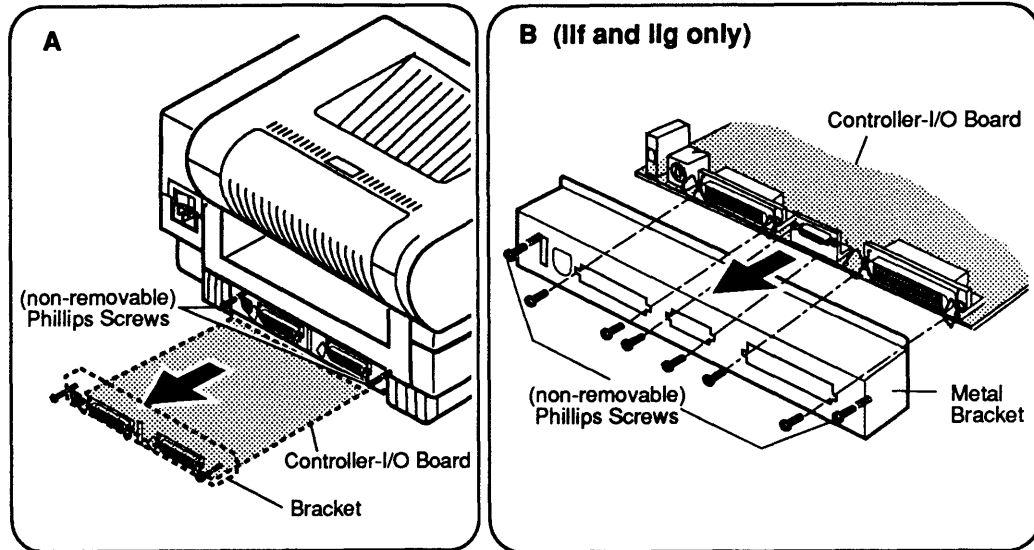

FIGURE 62

2. **Carefully** slide the controller-I/O board out of the printer. Handle the board by the metal bracket only.
3. SC/NT/NTX: Return the board to Apple computer with the metal I/O bracket attached.

IIf and IIg: Before returning the controller-I/O board to Apple, remove the screws that hold the metal I/O bracket to the controller board (Figure 62B). Remove the I/O bracket and keep it to install on the replacement controller board.

Replace

The controller-I/O board may require configuration prior to installation in the printer. Refer to Section 6, Additional Procedures, "Controller-I/O Board Installation" for configuration procedures.

1. If the printer does not have a Repair Log Label on the bottom panel, affix the label provided with the replacement controller-I/O board to the panel.

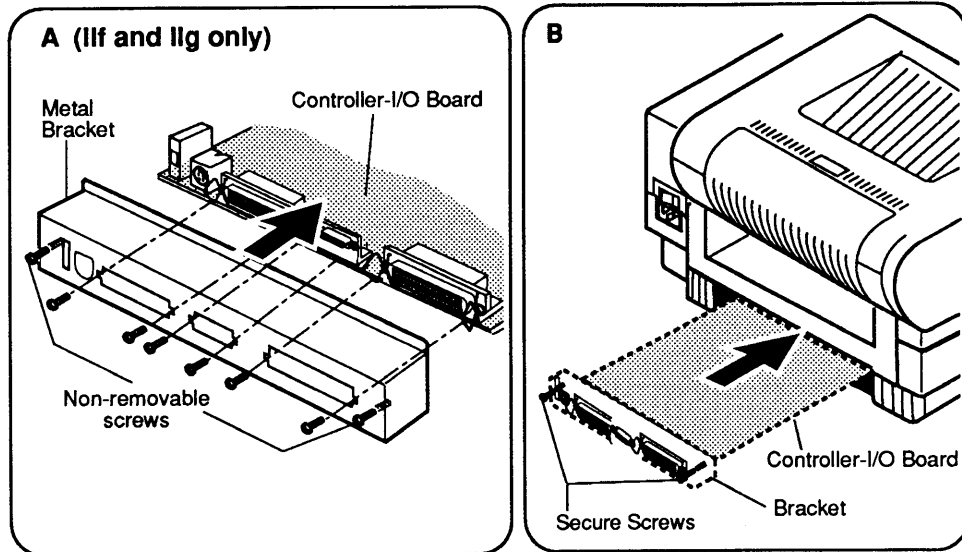

FIGURE 63

2. IIf and IIg only: Replace the metal I/O bracket and tighten the screws that hold the bracket to the controller-I/O board (Figure 63A).
3. Holding the controller-I/O board by the metal bracket at the back of the board and also at one side, slide the board into its compartment (Figure 63B) at the bottom of the printer. The opening is on the opposite side of the printer from the paper cassette.
4. Carefully push the controller-I/O board into the opening as far as it will go.
5. Tighten the two controller-I/O board screws.

□ DC CONTROLLER PCA

Materials Required

#2 Phillips screwdriver
Small needlenose pliers

Remove

1. Remove the controller-I/O board, bottom panel, and lower cover.
2. Disconnect the following cables from the DC controller PCA:
 - Fuser PCA cable, J206 (Figure 64, #1)
 - Lower fan cable, J207 (Figure 64, #2)
 - Power supply block cable, J208 (Figure 64, #3)
 - High-voltage power supply cable, J211 (Figure 64, #4)
 - Optical fiber cable, J201 (Figure 64, #5)

Note: If the optical fiber cable is difficult to disconnect, grasp the metal end with small needlenose pliers and carefully pull the cable out of the socket.
 - Scanning motor PCA cable, J203 (Figure 64, #6)
 - Laser diode PCA cable, J202 (Figure 64, #7)
3. Loosen the Phillips screw (Figure 64, #8) that secures the lower cover interlock switch to the chassis. Remove the interlock switch.
4. Locate the controller-I/O board guide rail closest to the DC controller PCA (Figure 64, #9). Remove the two Phillips screws (Figure 64, #10) that secure the guide rail to the chassis. Move the guide rail away from the DC controller PCA.
5. Remove the four Phillips screws (Figure 64, #11) that secure the DC controller PCA to the chassis.

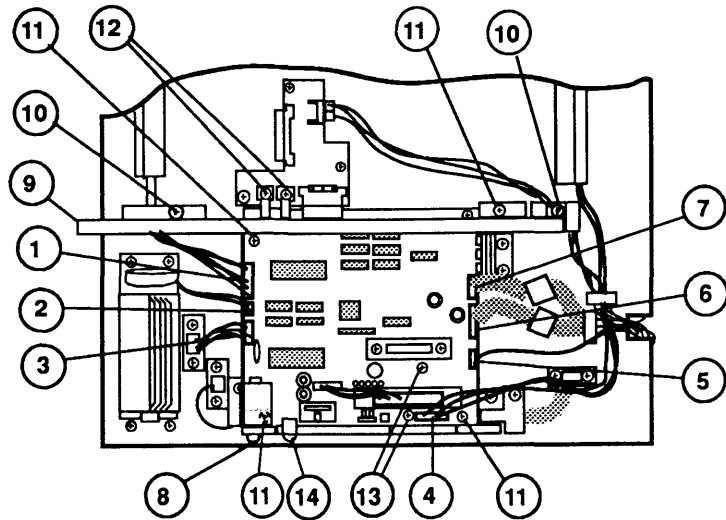

FIGURE 64

6. Remove the two Phillips screws (Figure 64, #12) that secure the power lugs to the connector PCA.
7. Remove the two Phillips screws (Figure 64, #13) that secure the two DC power supply connectors.
8. Carefully grasp the DC controller PCA by the edges, and pull the board firmly up and away from the connector PCA.
9. Remove the jumper at J209 (Figure 64, #14), if one is present.

Replace

1. If a jumper is not installed at J209 (Figure 64, #14) on the replacement DC controller PCA, install the jumper that you removed earlier. If you do not have a jumper, replace the DC controller PCA without one.
2. Place the DC controller PCA in position and replace the four screws (Figure 64, #11).
3. Replace the two DC power supply connector screws (Figure 64, #13).
4. Replace the two power lug screws (Figure 64, #12).

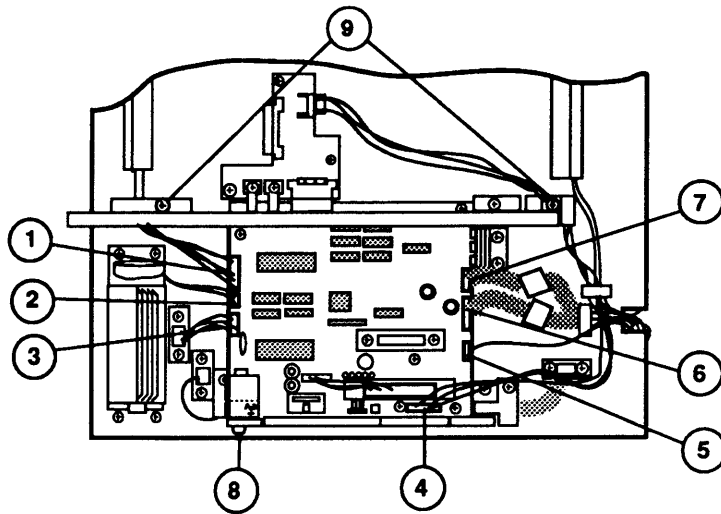

FIGURE 65

5. Place the controller-I/O board guide rail in position and replace the two screws (Figure 65, #9).
6. Place the cover interlock switch in position and replace the screw (Figure 65, #8).
7. Connect the following cables to the DC controller PCA:
 - Fuser PCA cable, J206 (Figure 65, #1)
 - Lower fan cable, J207 (Figure 65, #2)
 - Power supply block cable, J208 (Figure 65, #3)
 - High-voltage power supply cable, J211 (Figure 65, #4)
 - Optical fiber cable, J201 (Figure 65, #5)
 - Scanning motor PCA cable, J203 (Figure 65, #6)
 - Laser diode PCA cable, J202 (Figure 65, #7)
8. Replace the lower cover, bottom panel, and controller-I/O board.

□ CONNECTOR PCA

Materials Required

#2 Phillips screwdriver

Remove

1. Remove the controller-I/O board, bottom panel, and lower cover.

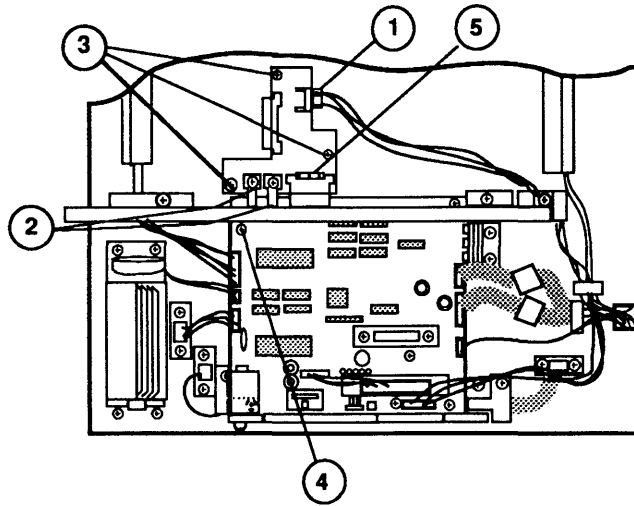

FIGURE 66

2. Disconnect the status panel cable from PCA connector J331 (Figure 66, #1).
3. Remove the two Phillips screws (Figure 66, #2) that secure the power lugs to the connector PCA.
4. Remove the three Phillips screws (Figure 66, #3) that secure the connector PCA to the chassis.
5. Remove the Phillips screw (Figure 66, #4) at the upper corner of the DC controller PCA.
6. **Carefully** lift the corner of the DC controller PCA and remove the connector PCA.

Replace

1. **Carefully** lift the corner of the DC controller PCA and mate the two halves of connector J205 (Figure 66, #5).

2. Lower the DC controller PCA and place the connector PCA on its positioning pins.
3. Replace the three connector PCA screws.
4. Replace the DC controller PCA screw.
5. Replace the two power connection screws.
6. Connect the status panel cable to connector PCA connector J331.
7. Replace the lower cover, bottom panel, and controller-I/O board.

□ LOWER FAN

Materials Required

#2 Phillips screwdriver

Remove

1. Remove the controller-I/O board, bottom panel, and lower cover.

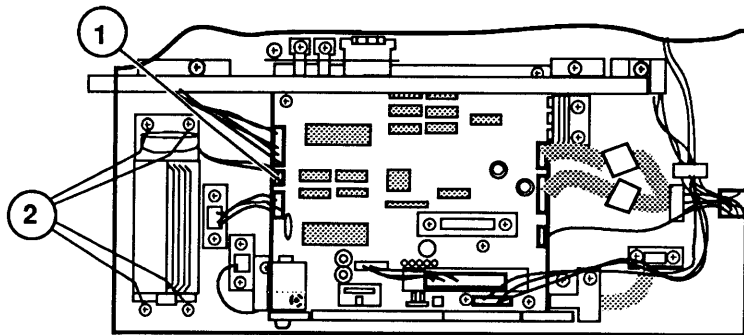

FIGURE 67

2. Disconnect the fan cable (Figure 67, #1) from DC controller PCA connector J207.
3. Remove the four Phillips screws (Figure 67, #2) that secure the fan to the chassis.
4. Remove the fan and the fan bracket.

Replace

1. Place the fan and the fan bracket in position and replace the four Phillips screws. The angled portion of the bracket should be positioned so that it angles toward the front of the printer.
2. Connect the fan cable to DC controller connector J207.
3. Replace the lower cover, bottom panel, and controller-I/O board.

□ TOP COVER

The top cover is not available from Apple as an assembly, but you may need to remove it in the course of removing other assemblies.

Materials Required

#2 Phillips screwdriver

Remove

1. Remove the cover set.

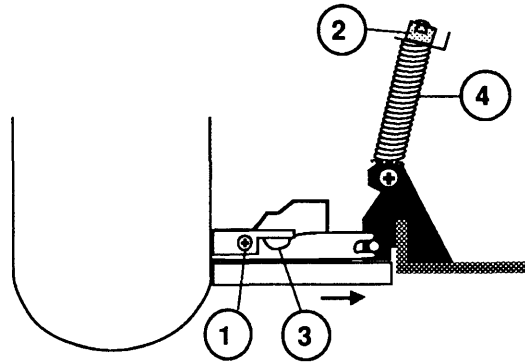

FIGURE 68

2. Remove the two Phillips screws (Figure 68, #1) that secure the left and right hinge guards to the hinges.
3. Lift the top cover assembly far enough to disengage the left and right slide blocks (Figure 68, #2) from their hinges. The tabs on the sliding block have to align with the slots (Figure 68, #3) in the hinge arm before you can slide the hinge mount and spring (Figure 68, #4) from the arm.

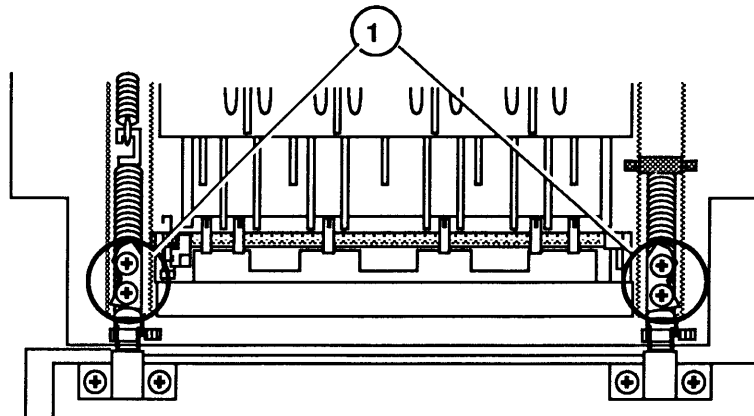

FIGURE 69

4. Remove the four Phillips screws (Figure 69, #1) that secure the hinge arms to the top cover.
5. Remove the top cover.

Replace

1. Place the top cover in position on the chassis. Be sure the hinges sit properly on the hinge shafts.
2. Replace the four hinge arm screws.
3. Lower the top cover far enough to engage the left and right slide blocks in their hinges.
4. Replace the hinge guards and their screws.
5. Replace the cover set.

MAIN TRAY

Materials Required

None

Remove

1. Remove the cover set and top cover.
2. Open the main tray.
3. Press either of the two arms of the main tray inward to release the catch. Remove the main tray.

Replace

1. Place the main tray in position on the top cover. Be sure to align the holes in the main tray arms with the pins in the top cover.
2. Replace the top cover and cover set.

☐ HEATER COVER

Materials Required

#2 Phillips screwdriver, stubby

Remove

1. Depress the release button and open the top cover.

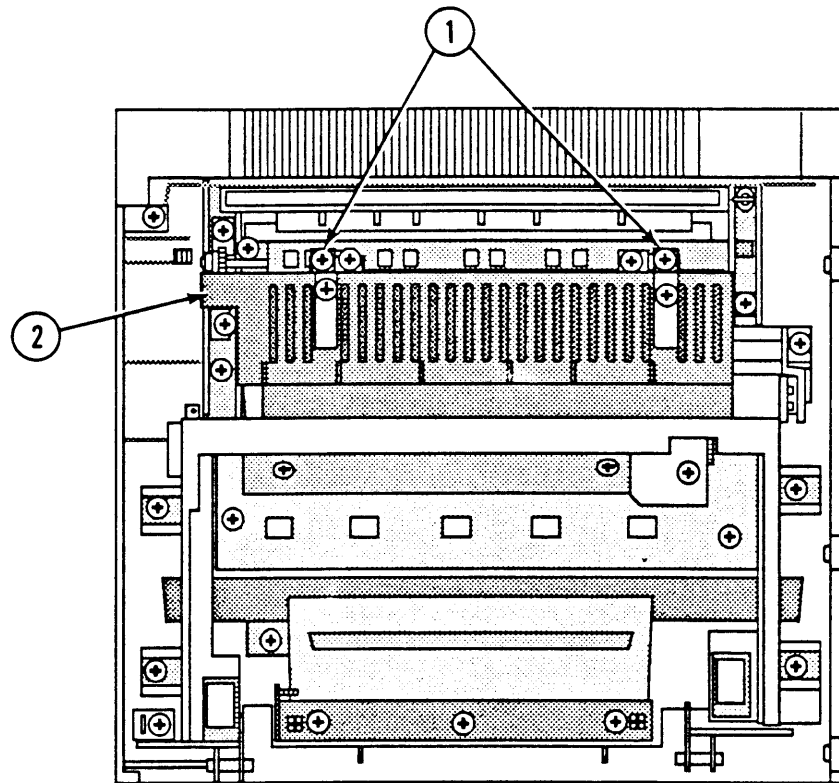

FIGURE 70

2. Remove the two Phillips screws (Figure 70, #1) that secure the heater cover (Figure 70, #2) to the top cover.
3. Pull on the heater cover to remove it from the top cover. A little bit of force may be required. Don't worry: you won't break anything.

Replace

1. Place the heater cover in position in the top cover.
2. Replace the two heater cover screws.

□ SHUTTER ASSEMBLY

Materials Required

#2 Phillips screwdriver

Remove

1. Depress the release button and open the top cover.

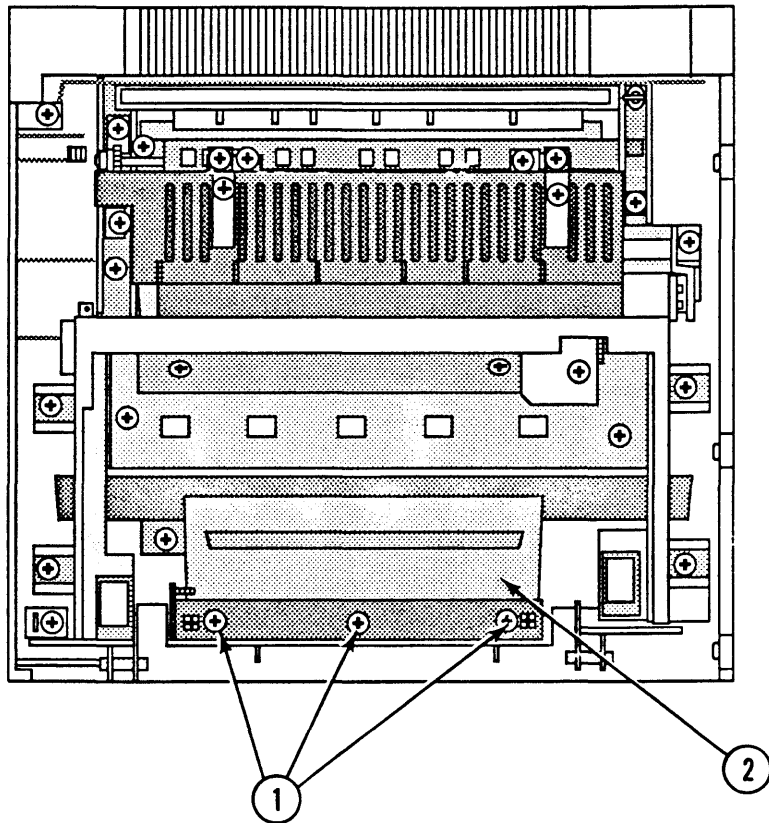

FIGURE 71

2. Remove the three Phillips screws (Figure 71, #1) that secure the shutter assembly (Figure 71, #2) to the top cover.

Replace

1. Use a clean, lint-free cloth to clean the mirror.
2. Place the shutter assembly in position in the top cover.
3. Replace the three shutter assembly screws.

□ SHUTTER ARM

Materials Required Small, flatblade screwdriver

Remove 1. Remove the shutter assembly.

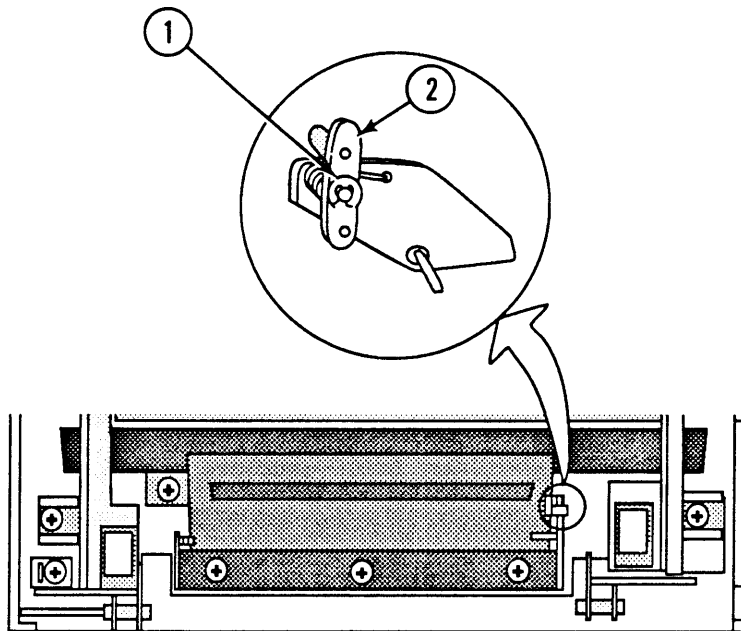

FIGURE 72

2. Using the screwdriver, remove the C-ring (Figure 72, #1) that secures the shutter arm (Figure 72, #2) to the mount.
3. Remove the shutter arm and the torsion spring.

Replace

1. Place the torsion spring and shutter arm in position on the mount. See Figure 72 for correct placement of the spring.
2. Replace the shutter arm C-ring.
3. Replace the shutter assembly.

□ MIRROR ASSEMBLY

Materials Required

#2 Phillips screwdriver

Remove

1. Remove the cover set, heater cover, and shutter assembly.

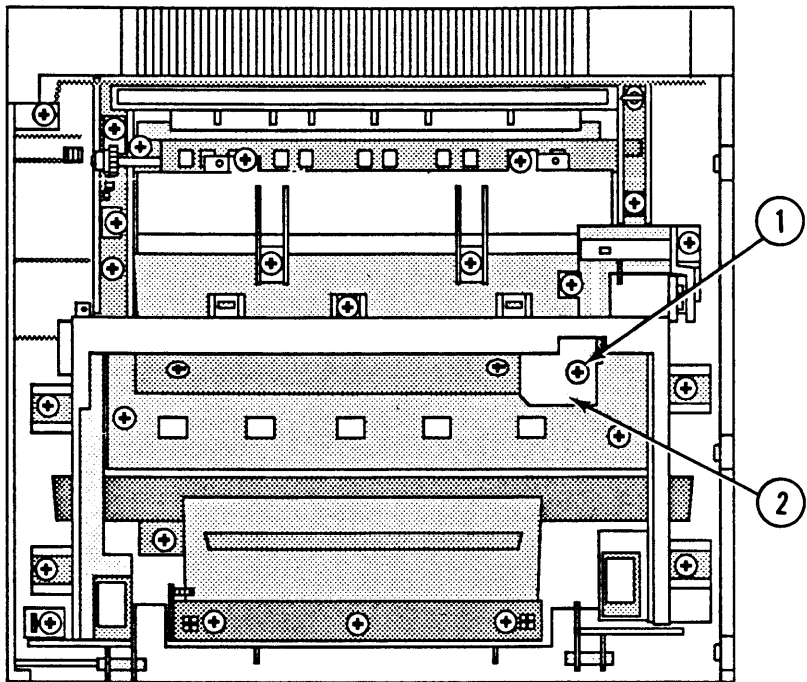

FIGURE 73

2. Remove the Phillips screw (Figure 73, #1) that secures the preconditioning exposure contact cover (Figure 73, #2) to the preconditioning exposure assembly. Remove the cover.

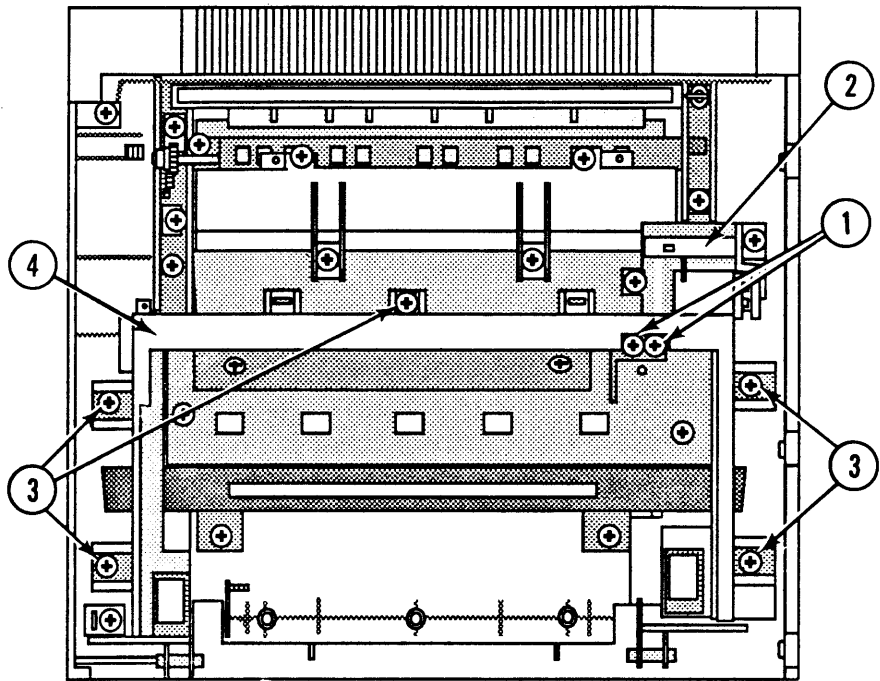

FIGURE 74

3. Remove the two Phillips screws (Figure 74, #1) that secure the preconditioning exposure assembly to the preconditioning exposure contact arm (Figure 74, #2).
4. Remove the five Phillips screws (Figure 74, #3) that secure the cartridge guide (Figure 74, #4) to the top cover. Remove the cartridge guide.
5. Remove the mirror assembly.

Replace

1. Place the mirror and cartridge guide together and in position in the top cover. Be sure the pins from the cartridge guide engage in their respective slots in the mirror assembly. **Do not touch the mirror.**

Note: The mirror can only be installed properly in the cartridge guide in one direction. If the mirror doesn't fully sit on the pins, flip it around and try again.

2. Replace the five cartridge guide screws.
3. Replace the two grounding spring arm screws.
4. Replace the preconditioning exposure contact cover on the preconditioning exposure assembly. Replace the cover screw.
5. Replace the shutter assembly, top cover, and cover set.

□ DELIVERY ASSEMBLY

Materials Required

#2 Phillips screwdriver

Remove

1. Remove the cover set and top cover

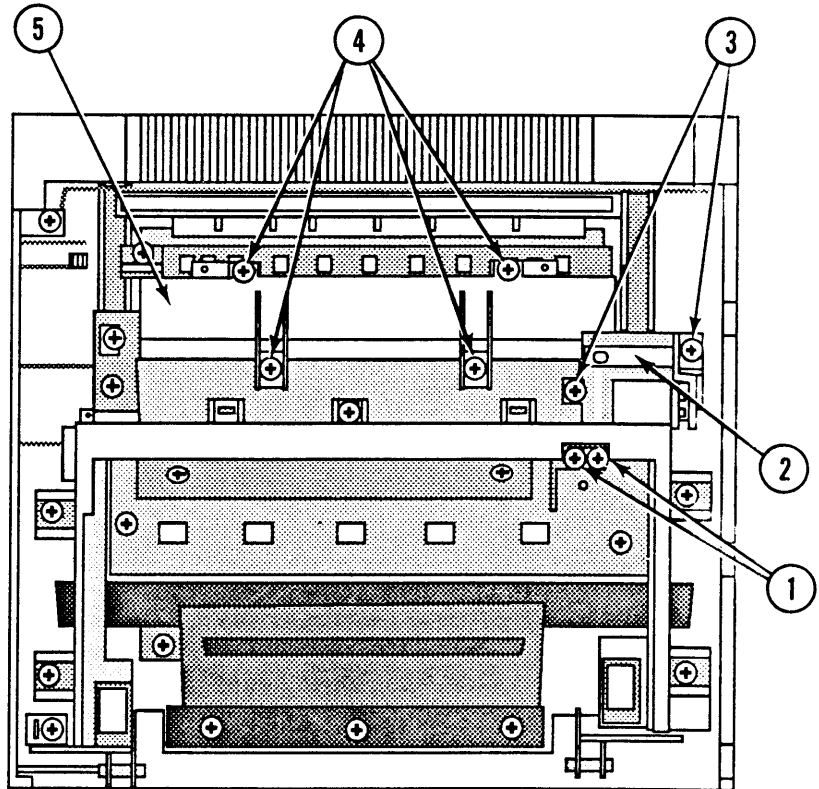

FIGURE 75

2. Remove the Phillips screw that secures the preconditioning exposure contact cover to the preconditioning exposure assembly. Remove the cover.
3. Remove the two Phillips screws (Figure 75, #1) that secure the preconditioning exposure assembly to the preconditioning exposure contact arm (Figure 75, #2)
4. Remove the two Phillips screws (Figure 75, #3) that secure the preconditioning exposure contact arm to the top cover. Remove the contact arm.

5. Remove the four Phillips screws (Figure 75, #4) that secure the lower delivery cover (Figure 75, #5) to the top cover and delivery assembly.

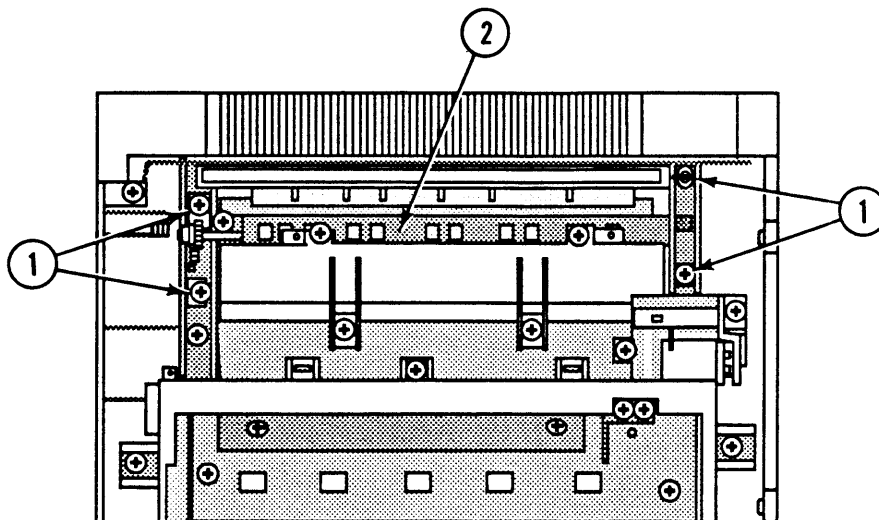

FIGURE 76

6. Remove the four Phillips screws (Figure 76, #1) that secure the delivery assembly (Figure 76, #2) to the top cover. Remove the delivery assembly and lower delivery cover.

Replace

1. Place the delivery assembly and lower delivery cover together and place them in position in the top cover.
2. Replace the four delivery assembly screws.
3. Replace the four lower delivery cover screws. The larger brass screws should be used in the **slotted** openings.
4. Place the contact arm in position. Replace the two mounting screws.
5. Replace the two contact arm screws.
6. Replace the preconditioning exposure contact cover and screw.
7. Replace the mirror assembly, shutter assembly, top cover, and cover set.

□ DELIVERY COUPLER ASSEMBLY

Materials Required #2 Phillips screwdriver

Remove

1. Remove the cover set, top cover, and delivery assembly.

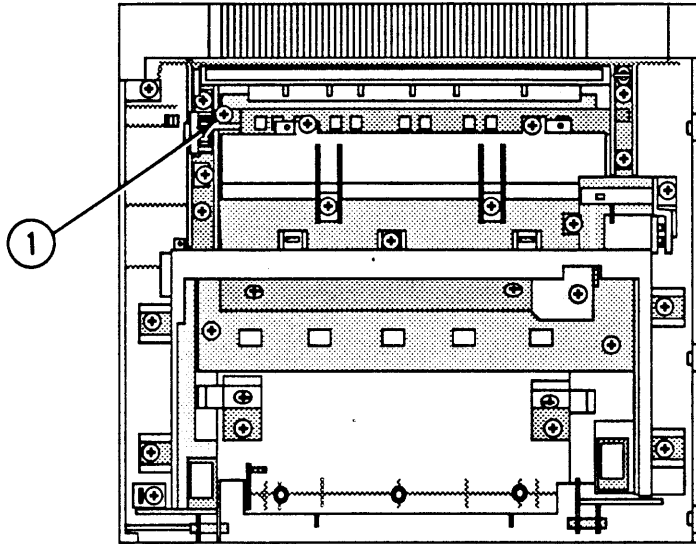

FIGURE 77

2. Remove the Phillips screw (Figure 77, #1) that secures the delivery coupler assembly to the delivery assembly. Remove the delivery coupler assembly.

Replace

1. Place the delivery coupler assembly in position on the delivery assembly. Replace the Phillips screw.
2. Replace the delivery assembly, top cover, and cover set.

□ STATIC CHARGE ELIMINATOR

Materials Required

#2 Phillips screwdriver

Remove

1. Remove the cover set, top cover, and delivery assembly.

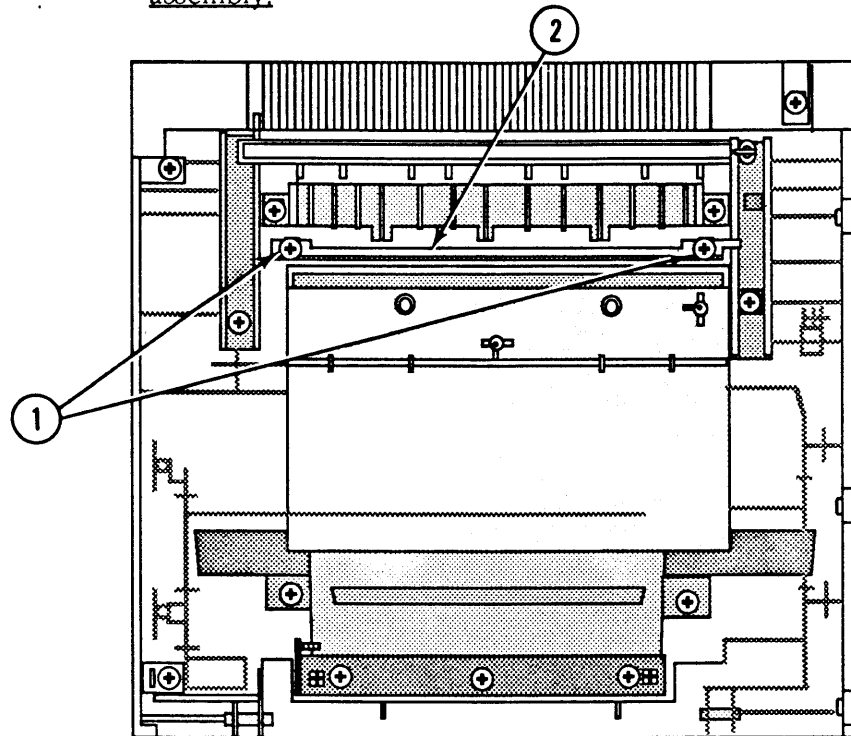

FIGURE 78

2. Remove the two Phillips screws (Figure 78, #1) that secure the static charge eliminator (Figure 78, #2) to the top cover. Remove the static charge eliminator.

Replace

1. Place the static charge eliminator in position in the top cover. The needles should be on the side **opposite** the main tray.
2. Replace the delivery assembly, top cover, and cover set.

□ PRECONDITIONING EXPOSURE ASSEMBLY

Materials Required #2 Phillips screwdriver

Remove 1. Open the top cover.

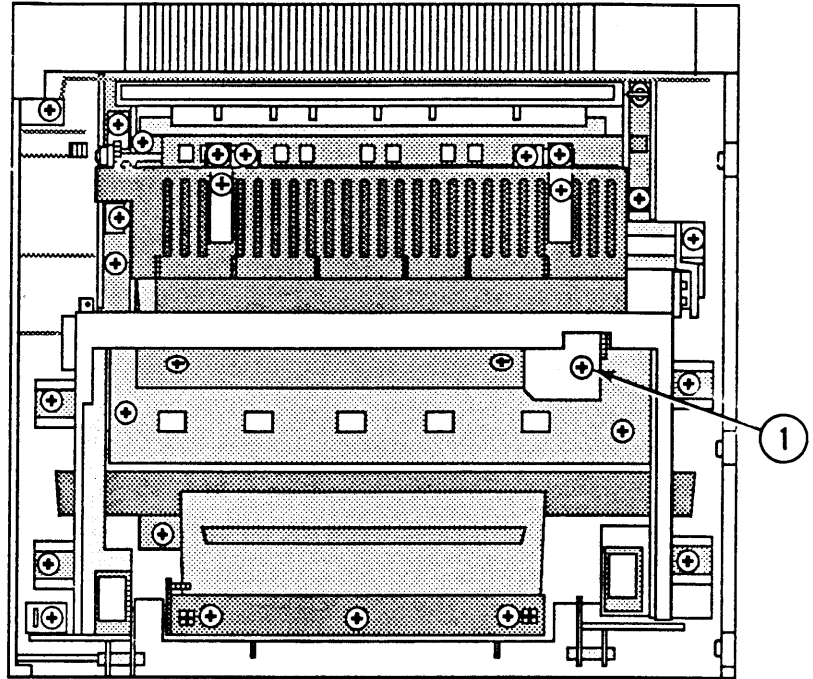

FIGURE 79

2. Remove the Phillips screw (Figure 79, #1) that secures the preconditioning exposure contact cover to the preconditioning exposure assembly.

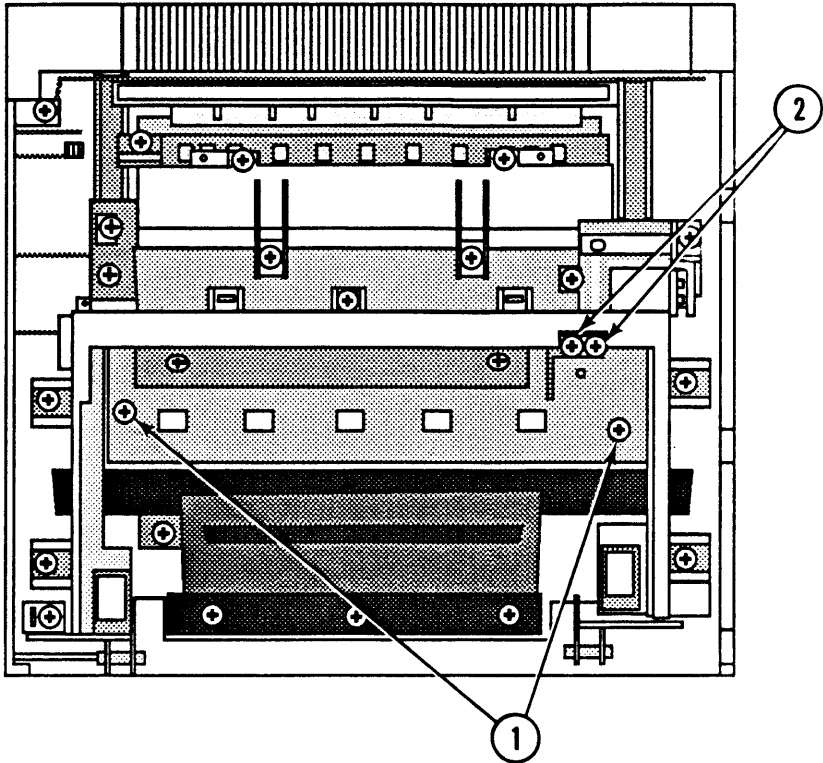

FIGURE 80

3. Remove the two Phillips screws (Figure 80, #1) that secure the preconditioning exposure assembly to the top cover.
4. Remove the two Phillips screws (Figure 80, #2) that secure the preconditioning exposure assembly to the contact arm.
5. Lift the preconditioning exposure assembly from the top cover.

Replace

1. Place the preconditioning exposure assembly in position in the top cover.
2. Replace the two preconditioning exposure assembly screws.
3. Replace the two grounding spring arm screws.
4. Place the small metal cover in place and install the Phillips screw.

□ COPY TRAY

Materials Required

#2 Phillips screwdriver

Remove

1. Remove the top cover, shutter assembly, mirror assembly and delivery assembly.

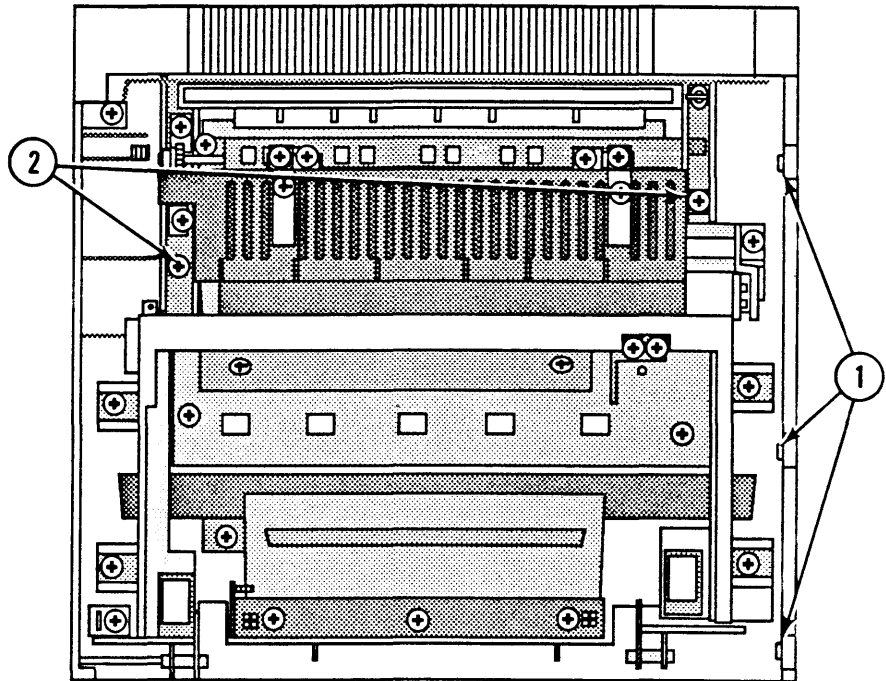

FIGURE 81

2. Remove the three Phillips screws (Figure 81, #1) that secure the upper front panel to the upper panel and copy tray. Remove the upper front panel.
3. Remove the two Phillips screws (Figure 81, #2) that secure the cover brackets to the copy tray.
4. Remove the two Phillips screws that secure the copy tray to the upper panel.
5. Pivot the bottom of the copy tray away from the top cover and remove the tray.

Replace

1. Place the copy tray in position against the top cover and replace the two screws.
2. Replace the two cover bracket screws.
3. Place the upper front panel in position and replace the three screws.
4. Replace the delivery assembly, mirror assembly, shutter assembly, and top cover.

□ PAPER DEFLECTOR

Materials Required

None

Remove

1. Open the top cover

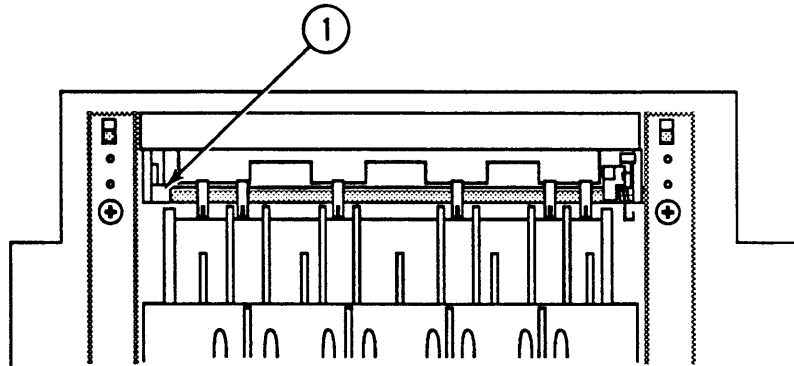

FIGURE 82

2. Release the left side (Figure 82, #1) of the paper deflector from the top cover by pressing downward on the deflector.
3. Slide the paper deflector to the left and remove it from the top cover.

Replace

1. Place the paper deflector in position. Refer to Figure 82 for correct placement of the spring.
2. Snap the left side of the paper deflector into its slot in the cover.



)

)

)



LaserWriter II

Section 4 – Troubleshooting

□ CONTENTS

4.3	Introduction
4.3	How to Use the Troubleshooting Section
4.3	Troubleshooting Procedure
4.3	Materials Required
4.4	Test Pages
4.5	Electronic Tests
4.7	Environmental Considerations
4.7	Print Engine Image Defects
4.7	Toner Cartridge Image Defects
4.8	Preliminary Checks
4.8	Setup Checklist
4.8	Iif and Iig RAM Requirements
4.9	Iif/g Diagnostic Chart
4.10	Flowchart 1 – LaserWriter II Functional Check
4.12	Flowchart 2 – LaserWriter II Print Engine Check
4.15	Flowchart 3 – LaserWriter II Print Engine Error
4.16	Table A—No Power
4.18	Table B—Delivery Rollers Do Not Rotate
4.20	Table C—Communication Problems
4.20	Table C1—SC Controller-I/O Board
4.21	Table C2—NT/NTX Controller-I/O Board: LocalTalk
4.22	Table C3—NT/NTX Controller-I/O Board: RS-232 Serial
4.23	Table C4—Iif/g Controller-I/O Board: LocalTalk
4.24	Table C5—Iif/g Controller-I/O Board: RS-232 Serial
4.25	Table C6—Iig Controller-I/O Board: Ethernet
4.27	Table D—Heater Bulb Does Not Operate
4.29	Table E—Cannot Feed Paper Manually
4.30	Table F—Jams Detected When There Are No Jams
4.31	Table G—Paper Jams Are Not Detected
4.32	Table H—Paper-Out LED Lights When There Is Paper
4.33	Table I—Paper-Out LED Doesn't Light with No Paper
4.34	Table J—Preconditioning Lamps Do Not Light
4.35	Table K—Laser/Scanner Malfunction

- 4.36 Table L—Erroneous Low-Toner Indicator
- 4.37 Table M—Print Quality Problems
 - 4.39 Table M1—Light Image: Whole Print
 - 4.42 Table M2—Dark Image: Whole Print
 - 4.43 Table M3—All-Blank Print
 - 4.45 Table M4—Black Image
 - 4.46 Table M5—Stained Print/Repetitive Defects
 - 4.47 Table M6—Black Image & Horizontal White Stripes
 - 4.47 Table M7—Stains on Back of Paper
 - 4.48 Table M8—Dark Vertical Lines
 - 4.48 Table M9—Sharp Horizontal Black Lines
 - 4.49 Table M10—Vertical Fogged Stripes
 - 4.50 Table M11—Horizontal Fogged Stripes
 - 4.51 Table M12—Blank Spots
 - 4.52 Table M13—Thin Vertical White Lines or Stripes
 - 4.53 Table M14—Faulty Registration
 - 4.54 Table M15—Poor Fusing: Image Smears Easily
 - 4.54 Table M16—Distortion
 - 4.55 Table M17—Waviness
 - 4.55 Table M18—Uneven Print Density
 - 4.56 Table M19—Foggy Print
 - 4.56 Table M20—Horizontal Banding
 - 4.57 Table M21—Wavy Print on Gray
 - 4.57 Table M22—Blotchy or Ghosting Printing
 - 4.57 Table M23—Image Does Not Print in Grayscale (LaserWriter IIf and IIg only)
- 4.58 Table N—Paper Transport Problems
 - 4.59 Table N1—No Paper Pickup
 - 4.60 Table N2—Jams in Pickup/Transfer Area
 - 4.61 Table N3—Jams in Separation/Feeder Guide Area
 - 4.62 Table N4—Jams in Fuser/Delivery Area
 - 4.63 Table N5—Sheets Stuck Together
 - 4.63 Table N6—Wrinkles
- 4.64 Table O—NT/NTX ROM and SIMM Test
- 4.65 Laser Power Output Check
- 4.68 DC Controller PCA Switches and Connectors
- 4.68 High-Voltage Power Supply Connector Contacts
- 4.69 Distribution PCA Sensors, Switches, and Solenoids
- Wiring Diagram (located in Section 8, Appendix)

Note: Detailed instructions for underlined steps are in Section 2, Take-Apart.

□ INTRODUCTION

How to Use the Troubleshooting Section

This troubleshooting section provides a logical and sequential method for isolating printer failures. If you are troubleshooting a LaserWriter IIf or IIG printer, start with the IIf/g Diagnostic Chart in this section. If you are troubleshooting a LaserWriter SC or NT/NTX printer, refer to Flowcharts 1–3.

Troubleshooting Procedure

To troubleshoot a LaserWriter II, follow these steps:

1. Check the printer setup and operating conditions by following the steps in "Setup Checklist."
2. To troubleshoot a LaserWriter II SC or NT/NTX, begin with Flowchart 1 and proceed sequentially, function by function, until you verify all the printer's main functions. To troubleshoot a LaserWriter IIf or IIG, begin with the IIf/g Diagnostic Chart and observe the printer's status LEDs.

In the event of a printer problem, the Flowcharts will refer you to the appropriate troubleshooting table for resolution of the failure. The IIf/g Diagnostic Chart will indicate the printer part that you must replace to correct the problem.

3. **If you replace a module or component and find that the problem remains**, reinstall the original module or component before proceeding.
4. When the printer is repaired, perform the appropriate preventive maintenance procedures described in Section 5, Preventive Maintenance.
5. **To clean a module**, refer to the cleaning procedures described in Section 5, Preventive Maintenance.

Materials Required

Multimeter
#1 Phillips screwdriver
#2 Phillips screwdriver
Small flat-blade screwdriver
Needlenose pliers
Grip-ring pliers
Diagonal cutters

Test Pages

The LaserWriter II printers produce a variety of test pages to facilitate setting up the equipment and diagnosing possible problems.

Engine Self-Test Page

The engine self-test page confirms the operation of the print engine. To produce this page, press the engine self-test switch (**Figure 4-1**), which is located on the side of the printer behind the access cover.

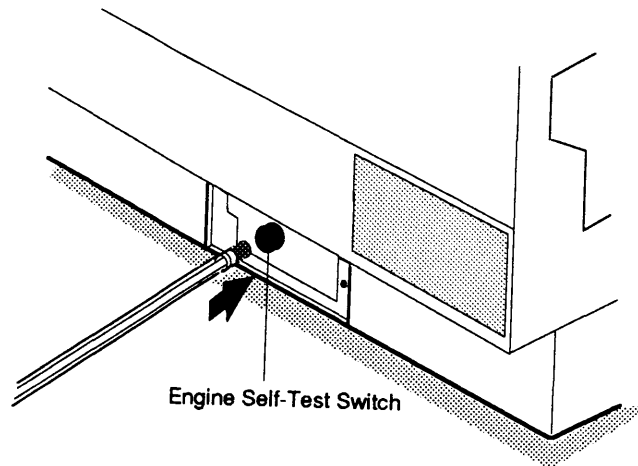

Figure 4-1 Engine Self-Test Switch

Startup Test Page

The startup test page confirms the operation of the printer. The LaserWriter II SC produces a startup test page only if the SCSI ID number is set to "7." The LaserWriter II NT, NTX, f, and g printers produce a startup test page each time they are switched on (unless the user switches the test page function off with PostScript software or the *LaserWriter Utility* program on the *LaserWriter II Installation* disk).

Electronic Tests

Many of the troubleshooting tables include electronic tests that you must perform to isolate a failed module or component. You need to know how to use the voltmeter and ohmmeter functions of the multimeter to perform these tests.

IMPORTANT: *If you do not have the required test equipment or do not wish to perform the electronic tests, you can skip the test and simply perform the action specified.*

Top-Cover Interlock Switch

In some troubleshooting steps, you must perform electronic tests with the top cover open. When the top cover of the printer is open, the electric current automatically switches off. To switch power on, depress the top-cover interlock switch (**Figure 4-2**). Use a nonmetallic object to depress the metal plate inside the housing.

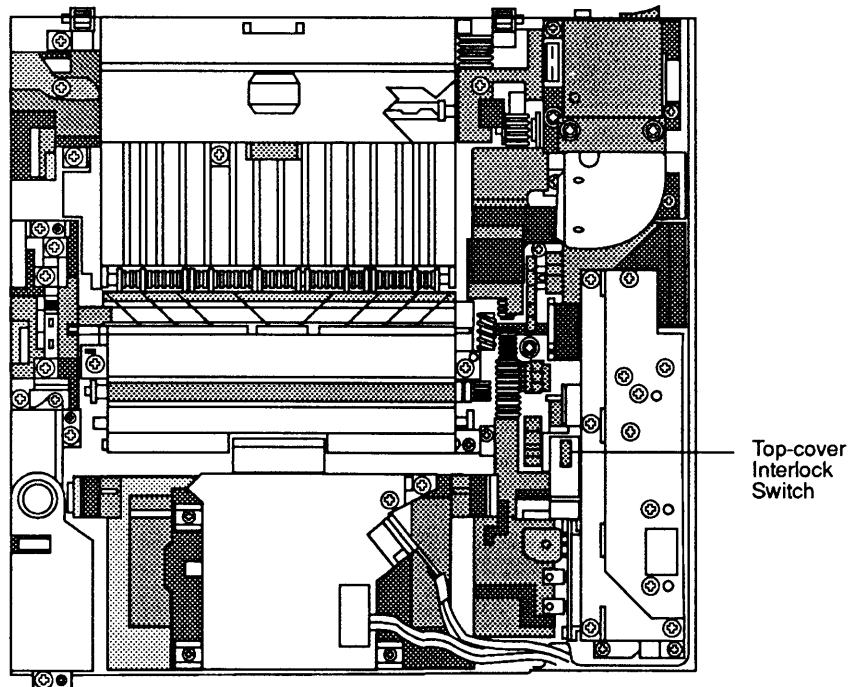

Figure 4-2 Top-Cover Interlock Switch

Drum-Sensitivity Switches

The drum-sensitivity switches SW301 and SW302 (Figure 4-3) are on the distribution PCA, just below the top-cover interlock switch. In some troubleshooting steps, you must depress the two switches simultaneously. This action causes the DC controller to behave as though a toner cartridge is installed.

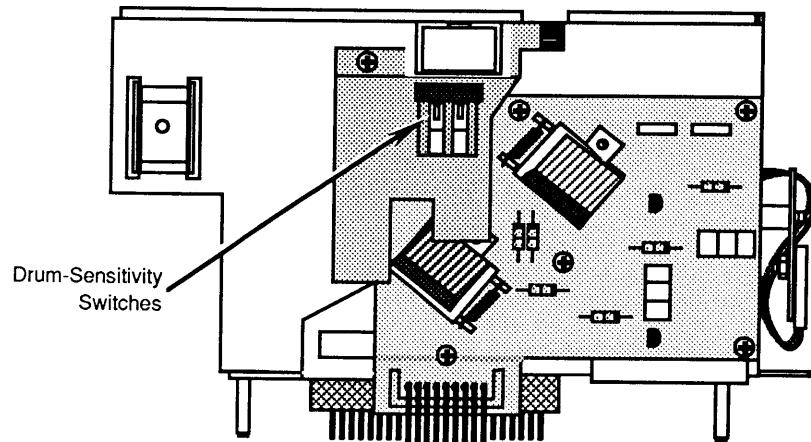

Figure 4-3 Drum-Sensitivity Switches

DC Controller PCA

To perform measurements on the DC controller PCA, place the printer on its back to remove the bottom panel and lower cover. Next, connect the multimeter leads to the indicated connector and pins. **Carefully** place the printer in normal operating position so that it rests on the controller-I/O board guide rails.

IMPORTANT: *The printer must be in its normal operating position when you perform measurements.*

□ ENVIRONMENTAL CONSIDERATIONS

Print Engine Image Defects

Moving the printer from a cold room to a warm room may cause condensation inside the printer. This temperature change may result in the following image defects:

- **Condensation** on optical surfaces—such as the **scanning mirror, lenses, or mirror assembly**—results in a **light print image**.
- **Condensation** on the **corona assemblies** causes corona leakage, resulting in **poor print quality**.
- **Condensation** on the **pickup guide and feed guide plate** results in **paper transport problems**.

To prevent condensation inside the printer, allow the printer to reach room temperature before printing. Acclimatization will take approximately two hours.

If condensation does occur, wipe only the *outside* of the printer and allow the printer to come to room temperature.

Toner Cartridge Image Defects

If the photosensitive drum in the toner cartridge is cold, the electrical resistance of the photosensitive layer will be high and may cause image contrast defects.

In addition, if you unseal the toner cartridge soon after taking it from a cold area to a warm one, condensation can occur inside the cartridge. This condensation can also cause image defects.

To prevent condensation from forming inside the toner cartridge, allow the cartridge to reach room temperature before you break the seal. Wait approximately two hours.

□ PRELIMINARY CHECKS

Setup Checklist

Before you begin troubleshooting, make sure the printer meets the following operating and setup conditions:

- The line voltage does not vary more than 10 percent from the voltage specified on the serial number plate.
- The LaserWriter II is on a solid and level surface.
- The room temperature is between 10 and 32.5 degrees C.
- The relative humidity is between 20 and 80 percent.
- The LaserWriter II is not near ammonia or other harmful gases.
- The LaserWriter II is not exposed to direct sunlight or open flame and is not in a dusty or dirty environment.
- The room is well ventilated.
- The print density adjustment dial is set correctly.
- The paper cassette is in the printer, has paper, and it not too full.
- All external cables and connectors are secure.
- The toner cartridge is in the printer and has toner.
- The fuser roller cleaner felt is installed and is clean.
- The DIP or rotary switches are set correctly.
- The printer paper is within specifications.
- The transfer corona wire is clean and unbroken.
- There is no visible damage to the inside or outside of the printer.

IIf and IIg RAM Requirements





Apple ships the LaserWriter IIf and IIg with sufficient RAM to print most types of documents. However, when printing complex pages (with complex graphics or multiple downloadable fonts) or attaching an external SCSI disk drive to the printer, make sure your IIf or IIg I/O controller-board has the following memory configuration:

- LaserWriter IIf: 4 MB of RAM
- LaserWriter IIg: 8 MB of RAM

□ IIf/g DIAGNOSTIC CHART

To use the LaserWriter IIf and IIg status LEDs for diagnostic purposes, set the rotary switch on the back of the printer to 4, and install a LaserWriter II Test Connector on the DB-25 serial port. Switch on the printer, observe the status LEDs, and compare them to the chart below. If an error condition exists, replace the printer component indicated.

Note: If you are unable to diagnose the printer problem after referring to the chart below, see Flowcharts 1-3 in this section.

STATUS LEDs				ERROR CONDITION	ACTION
					
flash	flash	flash	flash	No Error	—
on	on	flash	flash	Engine fuser assembly error	Refer to Table D
on	off	flash	flash	Engine laser assembly error	Refer to Table K or to the "Laser Power Output Check" section
off	on	flash	flash	Engine scanner assembly error	Refer to Table K
off	off	flash	flash	Controller-I/O board error	Refer to Table C
off	on	off	off	ROM #1 error	Replace ROM #1
off	on	off	on	ROM #2 error	Replace ROM #2
off	on	on	off	ROM #3 error	Replace ROM #3
off	on	on	on	ROM #4 error	Replace ROM #4
on	off	off	off	SIMM #1 error	Replace SIMM #1
on	off	off	on	SIMM #2 error	Replace SIMM #2
on	off	on	off	SIMM #3 error	Replace SIMM #3
on	off	on	on	SIMM #4 error	Replace SIMM #4
on	on	off	off	SIMM #5 error	Replace SIMM #5
on	on	off	on	SIMM #6 error	Replace SIMM #6
on	on	on	off	SIMM #7 error	Replace SIMM #7
on	on	on	on	SIMM #8 error	Replace SIMM #8

□ FLOWCHART 1 – LW II FUNCTIONAL CHECK (1 of 2)

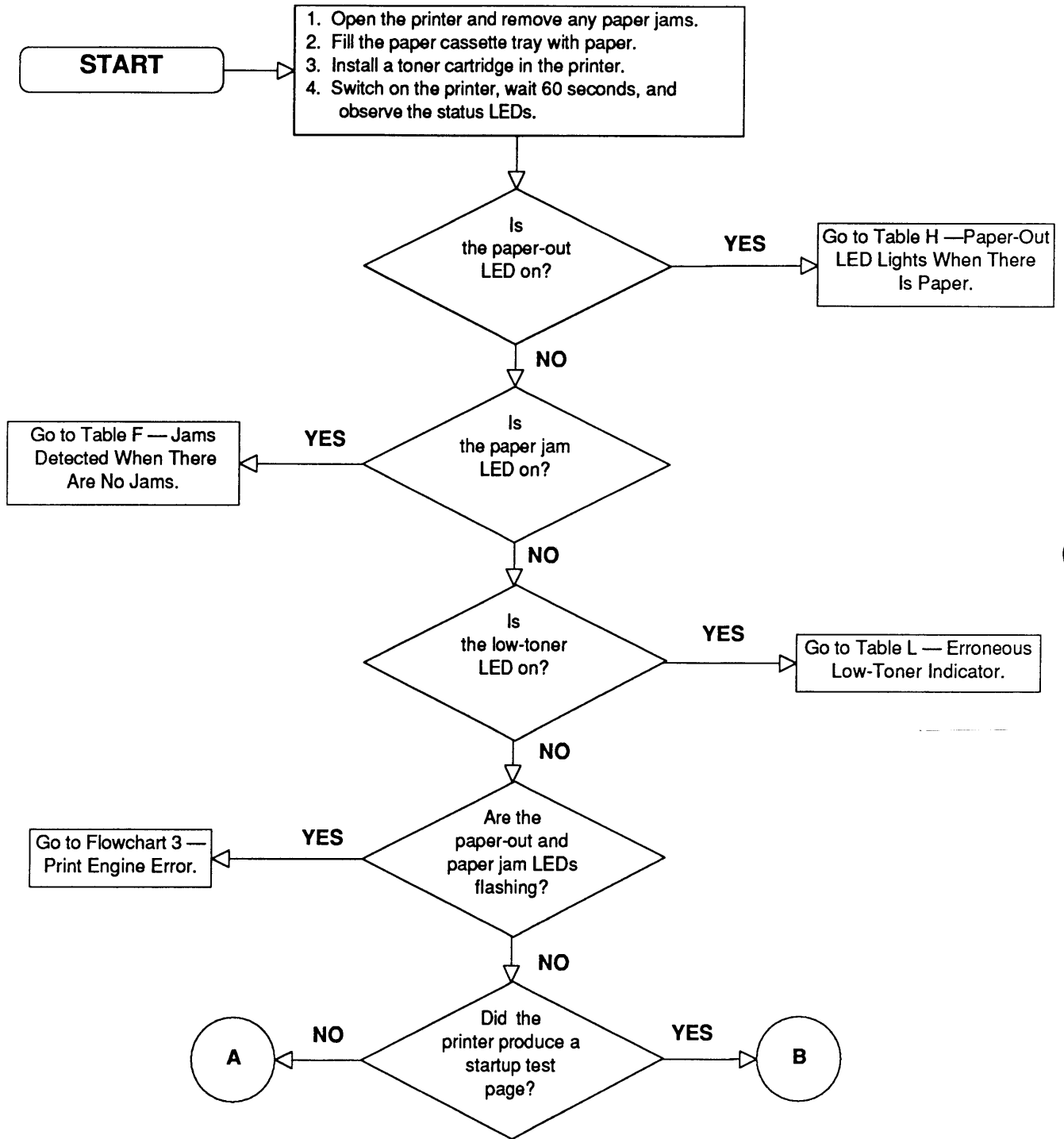

□ FLOWCHART 1 – LW II FUNCTIONAL CHECK (2 of 2)

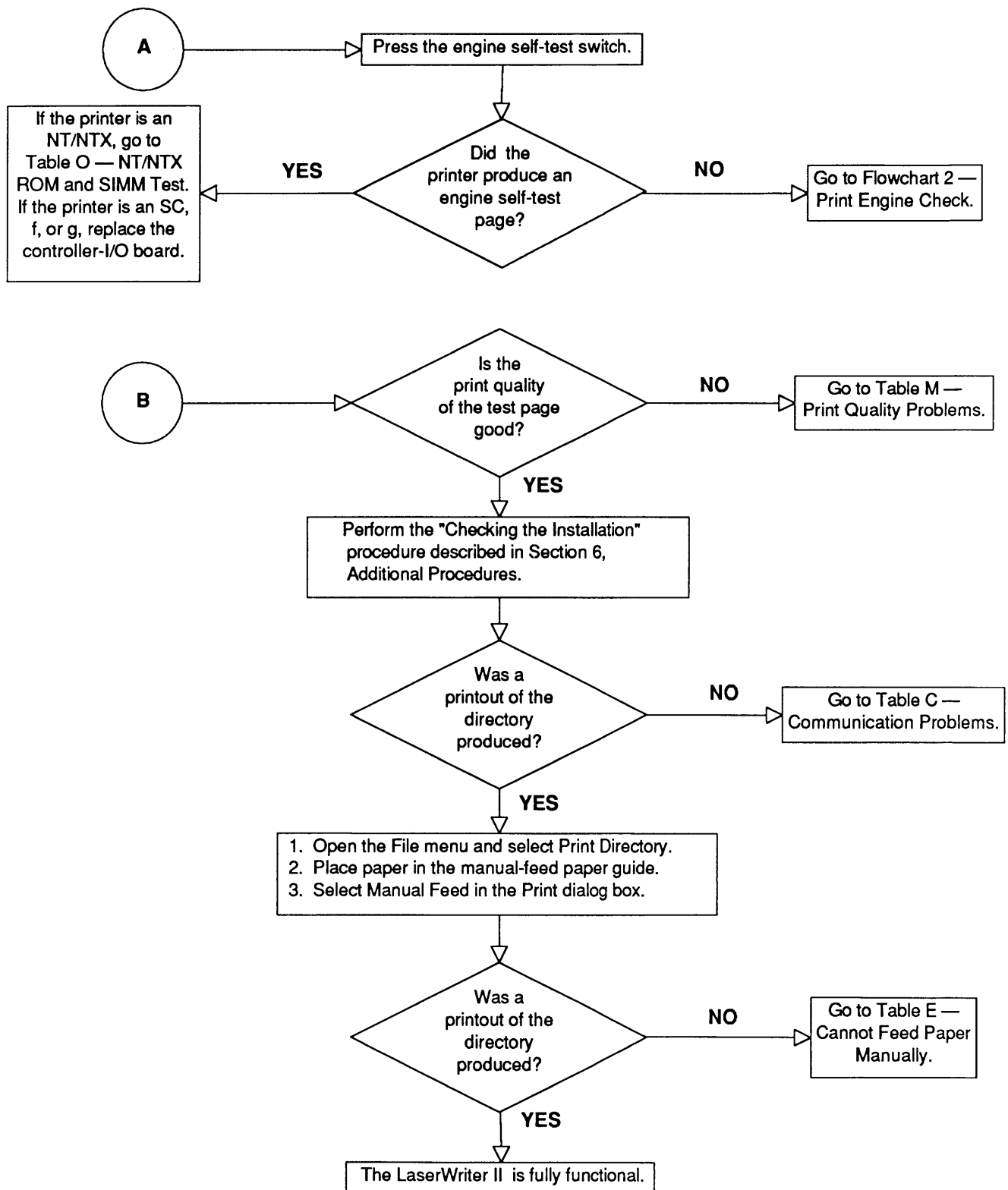

□ FLOWCHART 2 – LW II PRINT ENGINE CHECK (1 of 3)

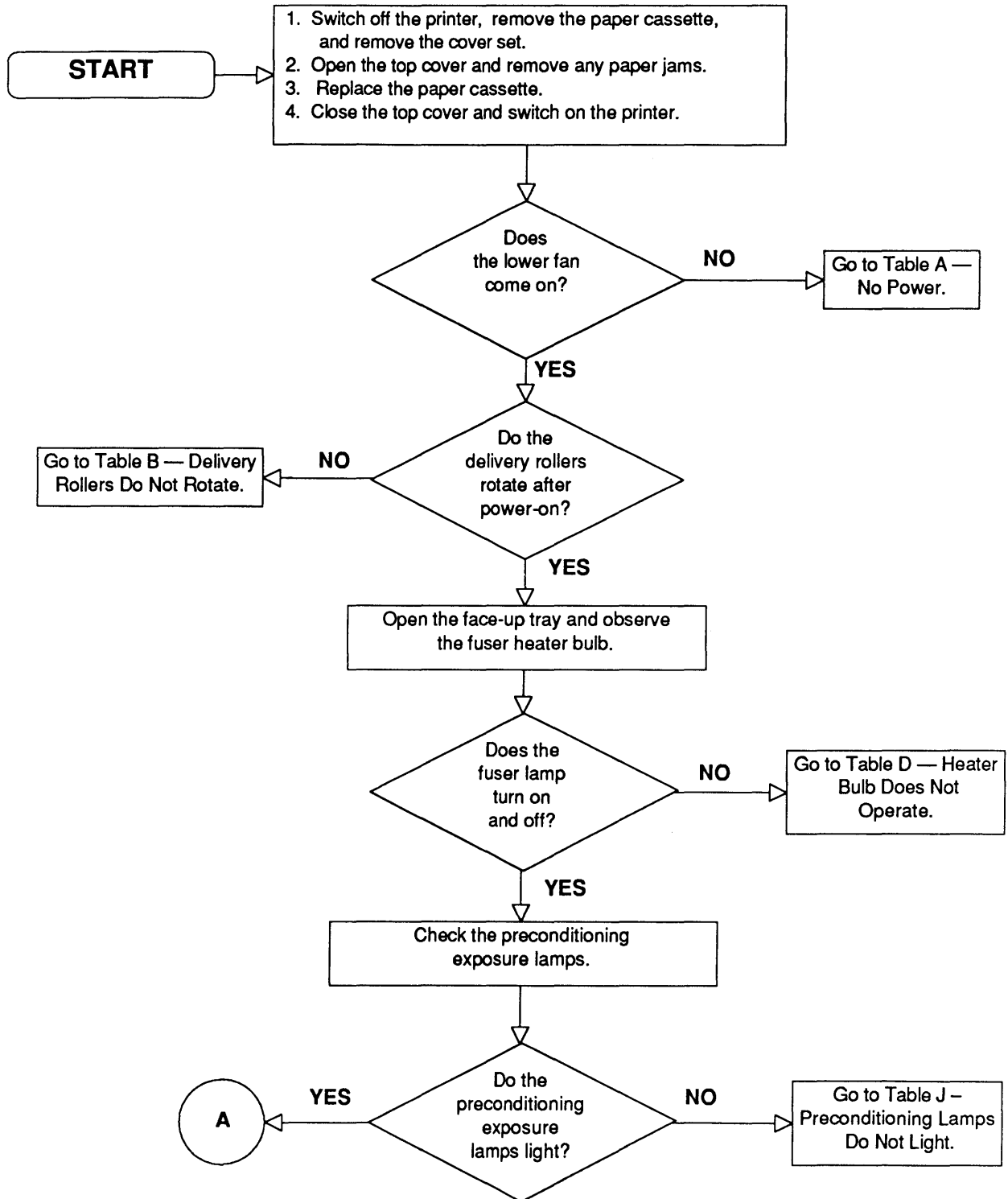

□ FLOWCHART 2 – LW II PRINT ENGINE CHECK (2 of 3)

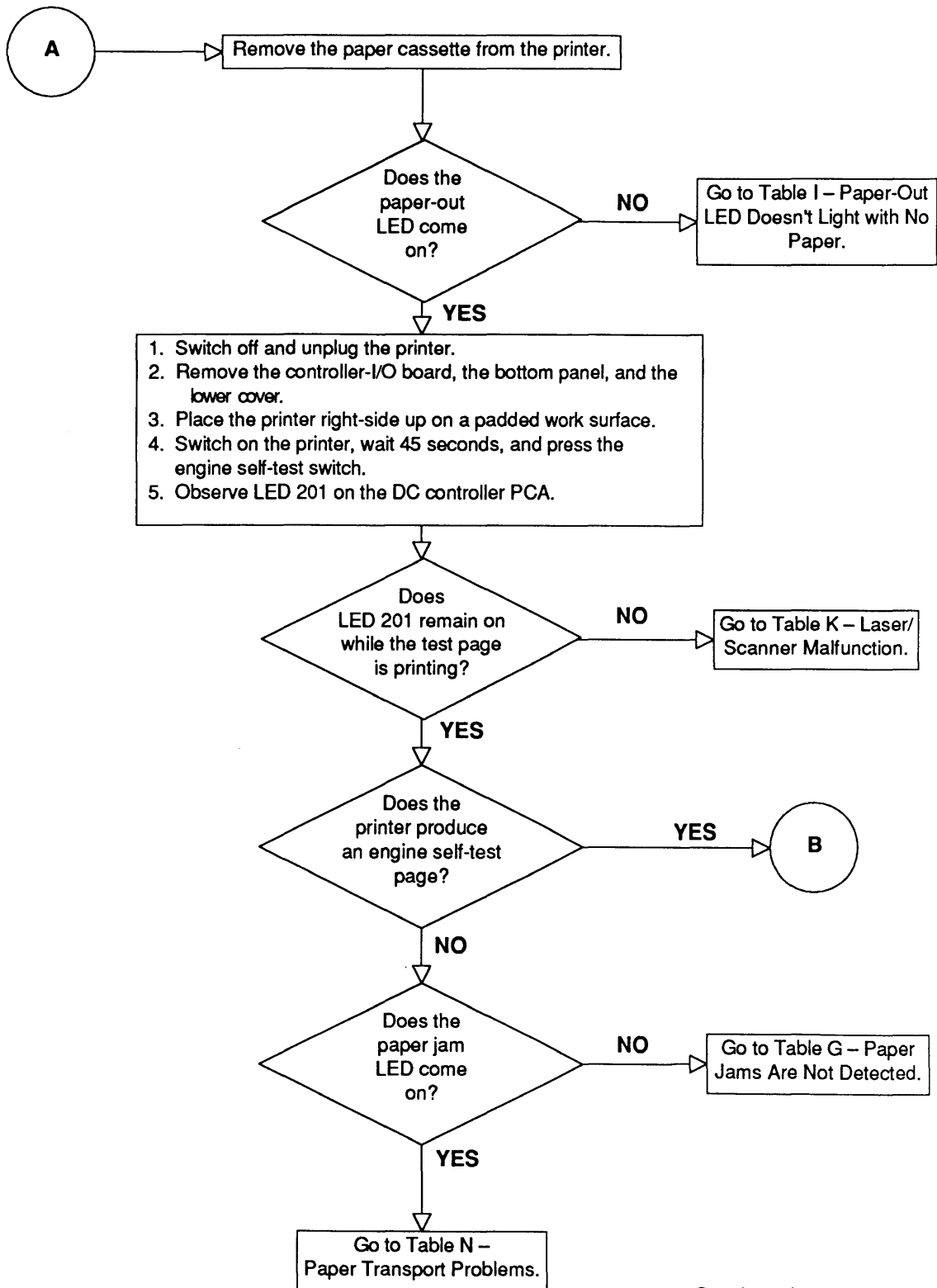

...Continued on next page

□ FLOWCHART 2 – LW II PRINT ENGINE CHECK (3 of 3)

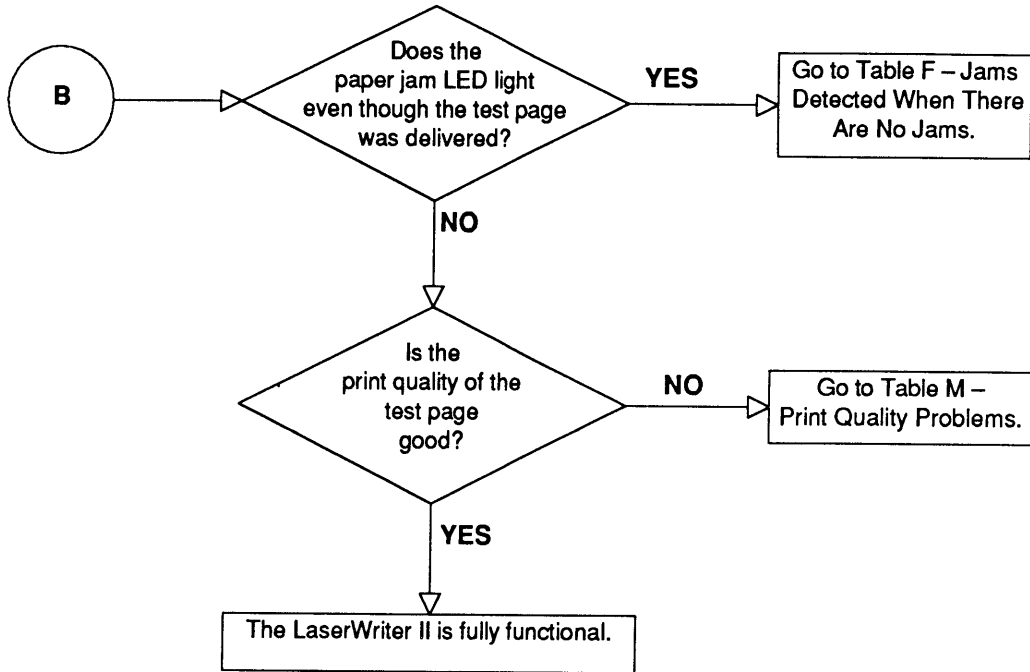

□ FLOWCHART 3 – LW II PRINT ENGINE ERROR

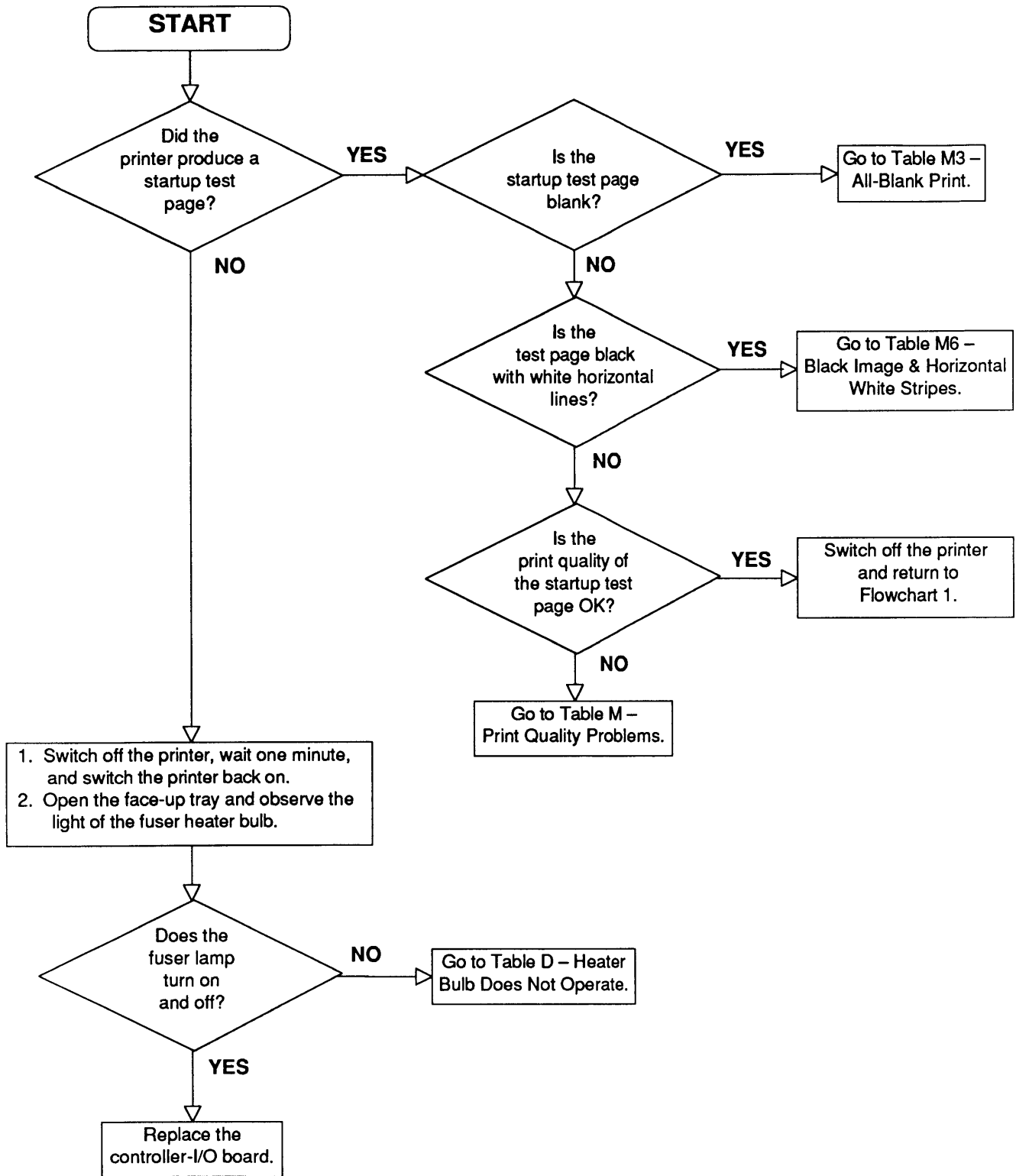

□ TABLE A—NO POWER (1 of 2)

<i>STEP</i>	<i>CHECK</i>	<i>RESULT</i>	<i>ACTION</i>
1	Is the printer plugged in?	No	Plug in the printer.
2	Is the printer switched on?	No	Switch on the printer.
3	Is the required voltage supplied at the AC outlet?	No	Try another AC outlet.
4	Is the top cover open?	Yes	Close the top cover.
5	Is the top-cover interlock lever damaged or broken?	Yes	Replace the top-cover interlock lever.
6	Is circuit breaker CB1 open?	Yes	Reset the circuit breaker. If the circuit breaker trips again after you switch the printer on, the printer has a short you must locate.
7	Is fuse F1 in the DC power supply open?	Yes	Replace the fuse. Use a 125-volt, 6.3-amp replacement.
8	Check whether AC power is reaching the DC power supply.		
	a) Unplug the printer and <u>remove the DC power supply.</u>		
	b) Plug in the printer, close the top cover, and switch on the printer.		
	c) Measure the voltage across the outer two pins of connector J502.		
	Is voltage present across the connector?	Yes	<u>Replace the DC power supply.</u>
		No	<u>Replace the power supply block.</u>
			<u>If the problem remains, replace the DC controller PCA.</u>

□ TABLE A—NO POWER (2 of 2)

<i>STEP</i>	<i>CHECK</i>	<i>RESULT</i>	<i>ACTION</i>
9	Measure the voltage across DC controller PCA connector pins J212-4 (+5 VDC) and J212-1 (GND).		
	Does the DC power supply generate +5 VDC?	No	<u>Replace the DC power supply.</u>
10	Measure the voltage across DC controller PCA connector pins J212-7 (REMOTE*) and J212-1.		
	Does the voltage change from approximately +4.5 VDC to 0 VDC when you switch power on?	Yes	<u>Replace the DC power supply.</u>
		No	<u>Replace the DC controller PCA.</u>

□ TABLE B—DELIVERY ROLLERS DO NOT ROTATE (1 of 2)

<i>STEP</i>	<i>CHECK</i>	<i>RESULT</i>	<i>ACTION</i>
1	Switch off the printer. Open the top cover, depress the top-cover interlock and drum-sensitivity switches, and switch the printer back on.		
	Does the main motor rotate to home position approximately one second after you switch the power on?	Yes	Check for obstructions in the delivery coupler assembly and delivery roller areas.
		No	Check for foreign objects in the drive gear or paper feed drive assemblies.
2	Is the main motor cable securely connected to DC power supply connector J3?	No	Connect the cable securely to connector J3. Return to step 1.
3	Switch off the printer. Disconnect the main motor cable from DC power supply connector J3. Measure the voltage between each of the following pairs of pins while printing an engine self-test page:		
	a) J3-5 (GND) & J3-1 (ø1)		
	b) J3-5 (GND) & J3-2 (ø1*)		
	c) J3-6 (GND) & J3-3 (ø2)		
	d) J3-6 (GND) & J3-4 (ø2*)		
	Does the voltage reach approximately +1.4 VDC one second after you switch power on?	Yes	<u>Replace the main motor.</u>

□ **TABLE B—DELIVERY ROLLERS DO NOT ROTATE (2 of 2)**

<i>STEP</i>	<i>CHECK</i>	<i>RESULT</i>	<i>ACTION</i>
4	<p>Switch off the printer and measure the voltage between each of the following pairs of pins on the DC controller PCA:</p> <ul style="list-style-type: none"> a) J212-8 (A) & J212-1 (GND) b) J212-9 (A*) & J212-1 (GND) c) J212-10 (B) & J212-1 (GND) d) J212-11 (B*) & J212-1 (GND) <p>Switch the printer off and then back on for each set of measurements.</p> <p>Does the voltage of each pair of pins reach approximately +1 VDC one second after you switch power on?</p>	Yes	<u>Replace the DC power supply.</u>
		No	<u>Replace the DC controller PCA.</u>

□ TABLE C—COMMUNICATION PROBLEMS

Use the table appropriate for the controller-I/O board and communication mode(s) being used.

□ TABLE C1—SC CONTROLLER-I/O BOARD

STEP	CHECK	RESULT	ACTION
1	Are the SCSI cable connections and terminators correct and secure?	No	Tighten the cable connections or refer to the <i>Owner's Guide</i> for proper cabling information.
2	Are the SCSI cables and terminators good? (Have you tried the cables elsewhere?)	No	Replace defective cable(s) and terminator(s).
3	Is the SCSI device address set to the same address as another device on the daisy chain?	Yes	Change the SCSI device address to a different address.
4	Is the LaserWriter SC device driver installed in the System Folder and the correct printer selected using the Chooser?	No	Copy the driver to the startup disk System Folder and select the printer using Chooser.
5	Have you tried a different computer?	No	Try a different computer.
6	Have you tried a different SC controller-I/O board?	No	Replace the SC controller-I/O board with a known-good board.
7	Can the computer now print?	Yes	Finished.
		No	Reseat the interconnect PCA and DC controller PCA. If the problem persists, first replace the interconnect PCA and then the DC controller PCA.

□ TABLE C2—NT/NTX CONTROLLER-I/O BOARD: LOCALTALK

STEP	CHECK	RESULT	ACTION
1	Are the LocalTalk cable connections correct and secure?	No	Tighten the cable connections or refer to the <i>Owner's Guide</i> for proper cabling information.
2	Are the DIP switches on the controller-I/O board set correctly?	No	Set the DIP switches as shown in the <i>Peripheral Interface Guide</i> .
3	Are the LocalTalk cables and connectors good? (Have you tried the cables elsewhere?)	No	Replace defective cables(s) and connectors.
4	Is the appropriate software installed on the application disk?	No	Install the correct software.
5	Have you tried a different computer?	No	Try a different computer.
6	Have you tried a different NT/NTX controller-I/O board?	No	Replace the NT/NTX controller-I/O board with a known-good board.
7	Can the computer now print?	Yes	Finished.
		No	Reseat the interconnect PCA and DC controller PCA. If the problem persists, first replace the interconnect PCA and then the DC controller PCA.

□ TABLE C3—NT/NTX CONTROLLER-I/O BOARD: RS-232 SERIAL

STEP	CHECK	RESULT	ACTION
1	Are the RS-232 serial cable connections correct and secure?	No	Tighten the cable connections or refer to the <i>Owner's Guide</i> for proper cabling information.
2	Are the DIP switches on the controller-I/O board set correctly?	No	Set the DIP switches as shown in the <i>Peripheral Interface Guide</i> .
3	Are the RS-232 serial cables and connectors good? (Have you tried the cables elsewhere?)	No	Replace defective cables(s) and connectors.
4	Have you tried a different computer?	No	Try a different computer.
5	Have you tried a different NT/NTX controller-I/O board?	No	Replace the NT/NTX controller-I/O board with a known-good board.
6	Can the computer now print?	Yes	Finished.
		No	Reseat the interconnect PCA and DC controller PCA. If the problem persists, first replace the interconnect PCA and then the DC controller PCA.

□ TABLE C4—IIf/g CONTROLLER-I/O BOARD: LOCALTALK

STEP	CHECK	RESULT	ACTION
1	Are the LocalTalk cable connections correct and secure?	No	Tighten the cable connections or refer to the <i>Owner's Guide</i> for proper cabling information.
2	Is a second cable plugged into the printer's LocalTalk connector box but not attached to a computer (i.e., a cable left dangling)?	Yes	Disconnect the second cable from the printer's LocalTalk connector box.
3	Are the switch settings correct on the controller-I/O board?	No	Select the correct switch settings as shown in the <i>Peripheral Interface Guide</i> .
4	Are the LocalTalk cables and connectors good? (Have you tried the cables elsewhere?)	No	Replace defective cables(s) and connectors.
5	Is the appropriate software installed on the application disk?	No	Install the correct software.
6	Have you tried a different computer?	No	Try a different computer.
7	Have you tried a different IIf or IIg controller-I/O board?	No	Replace the IIf or IIg controller-I/O board with a known-good board.
8	Can the computer now print?	Yes	Finished.
		No	Reseat the interconnect PCA and DC controller PCA. If the problem persists, first replace the interconnect PCA and then the DC controller PCA.

□ TABLE C5—IIf/g CONTROLLER-I/O BOARD: RS-232 SERIAL

STEP	CHECK	RESULT	ACTION
1	Are the RS-232 serial cable connections secure and correct?	No	Tighten the connections or refer to the <i>Owner's Guide</i> for proper cabling information.
2	Are the switch settings on the controller-I/O board correct?	No	Select the correct switch settings as shown in the <i>Peripheral Interface Guide</i> .
3	Are the RS-232 serial cables and connectors good? (Have you tried the cables elsewhere?)	No	Replace defective cables(s) and connectors.
4	Is the printer connected to a Macintosh computer via an RS-232 serial cable?	Yes	Try connecting the printer to the computer via a LocalTalk cable.
5	Have you tried a different computer?	No	Try a different computer.
6	Have you tried a different IIf or IIg controller-I/O board?	No	Replace the IIf or IIg controller-I/O board with a known-good board.
7	Can the computer now print?	Yes	Finished.
		No	Reseat the interconnect PCA and DC controller PCA. If the problem persists, first replace the interconnect PCA and then the DC controller PCA.

□ TABLE C6—IIg CONTROLLER-I/O BOARD: ETHERNET (1 of 2)

STEP	CHECK	RESULT	ACTION
1	Are the Ethernet cable connections correct and secure?	No	Tighten the cable connections or refer to the <i>Owner's Guide</i> for proper cabling information.
2	Is a second cable plugged into the printer's Ethernet connector but not attached to a computer (i.e., a cable left dangling)?	Yes	Disconnect the second cable from the printer's Ethernet connector.
3	Does the printer appear in the Chooser?	No	If you are using a third-party cabling system, make sure the cabling system is properly terminated.
4	Are the switch settings on the controller-I/O board correct?	No	Select the correct switch settings as shown in the <i>Peripheral Interface Guide</i> .
5	Are the Ethernet cables and connectors good? (Have you tried the cables elsewhere?)	No	Replace defective cables(s) and connectors.
6	Is the appropriate printer driver software installed?	No	Install the correct printer driver.
7	Is the correct network software installed?	No	If you connect the printer to an Ethernet network, the network software must support AppleTalk Phase 2.
8	Have you tried a different computer?	No	Try a different computer.

...Continued on next page

□ TABLE C6—IIg CONTROLLER-I/O BOARD: ETHERNET (2 of 2)

<i>STEP</i>	<i>CHECK</i>	<i>RESULT</i>	<i>ACTION</i>
9	Have you tried a different IIg controller-I/O board?	No	Replace the IIg controller-I/O board with a known-good board.
10	Can the computer now print?	Yes	Finished.
		No	Reseat the interconnect PCA and DC controller PCA. If the problem persists, first replace the interconnect PCA and then the DC controller PCA.

□ TABLE D—HEATER BULB DOES NOT OPERATE (1 of 2)

Note: Whenever the fusing system malfunctions, capacitor C211 on the DC controller PCA charges and puts the printer in an error state. The printer remains in the error state until C211 discharges (20 to 30 minutes). If the fusing system fails, switch the power off for 20 to 30 minutes, or replace the failed module and manually discharge C211.

Note: If interlock switch SW205 on the DC controller PCA is not properly installed, AC power to the fuser heater bulb may be cut off. If the lower cover is removed, make sure the interlock switch lever can depress SW205.

STEP	CHECK	RESULT	ACTION
1	Remove the fuser assembly and measure the resistance through the thermoprotector (TP1).		
	Is there continuity through the thermoprotector?	No	<u>Replace the fuser assembly.</u>
2	Measure the resistance across the thermistor by connecting the multimeter to fuser PCA connector pins J331-4 (FSRTH) and J331-5 (GND).		
	Is the resistance at room temperature between 1 and 1.6 megohms?	No	<u>Replace the fuser assembly.</u> If the problem persists, check the cable connections between the fuser PCA (J331) and the DC controller PCA (J206). If the connections are secure, replace the DC-controller-to-fuser cable.
3	Measure the resistance across fuser assembly connector J103.		
	Is there continuity through the heater bulb?	No	<u>Replace the heater bulb.</u>
<p><u>CAUTION:</u> <i>Dust and fingerprints can severely damage the bulb. Handle the bulb by its plastic handle only!</i></p>			

...Continued on next page

□ TABLE D—HEATER BULB DOES NOT OPERATE (2 of 2)

<i>STEP</i>	<i>CHECK</i>	<i>RESULT</i>	<i>ACTION</i>
	For the next step, you will need to <u>remove the controller-I/O board, cover set, bottom panel, and lower cover</u> . Install a toner cartridge.		
4	Reinstall the fuser assembly. Close the top cover. Connect the multimeter across DC controller connector pins J208-2 (FSRD) and J208-3 (GND).		
	Does the voltage change from approximately +5 VDC to 0 VDC when you switch the power on?	Yes	<u>Replace the power supply block</u> , and discharge capacitor C211 on the DC controller PCA. If the problem persists, check the cable connections between the power supply block (J101) and the DC controller PCA (J208). If the connections are secure, replace the cable that connects the DC controller to the power supply block.
		No	<u>Replace the DC controller PCA.</u>

□ TABLE E—CANNOT FEED PAPER MANUALLY

<i>STEP</i>	<i>CHECK</i>	<i>RESULT</i>	<i>ACTION</i>
	<p>– Connect the multimeter to DC controller PCA connector pins J213-9 (MFPS*) and J213-6 (GND). Place a sheet of paper on the top of the paper cassette and slide the paper far enough into the printer to trigger Manual Feed Paper Sensor PS302.</p>		
	Does the voltage change from approximately +5 VDC to 0 VDC as you insert the paper?	No	<u>Replace the distribution PCA.</u>
		Yes	<u>Replace the DC controller PCA.</u>

TABLE F—JAMS DETECTED WHEN THERE ARE NO JAMS

<i>STEP</i>	<i>CHECK</i>	<i>RESULT</i>	<i>ACTION</i>
1	Does the Paper Jam LED immediately light when you switch the printer on?	Yes	Check that no paper fragments or other obstructions are in the fuser assembly.
2	Is the paper-delivery-sensing lever in the fuser assembly damaged or broken?	Yes	<u>Replace the delivery-sensing lever.</u>
3	Is the new version of the delivery-sensing lever installed? (Refer to Take-Apart, Delivery-Sensing Lever.)	No	<u>Replace the delivery-sensing lever.</u>
4	Remove the left contact cap from the fuser assembly. Switch on the printer. Connect the multimeter across fuser PCA connector pins J331-6 and J331-7 (Figure 4-4). (The fuser PCA is the small circuit board attached to the fuser assembly. Connector J331 is the 7-pin connector on the board.)		
	Does the voltage change from +5 VDC to 0 VDC as you move the delivery sensor lever back and forth?	No	<u>Replace the fuser assembly.</u>
		Yes	Verify that the cabling is in tact. If it is, <u>replace the DC controller PCA.</u>

TABLE G—PAPER JAMS ARE NOT DETECTED

STEP	CHECK	RESULT	ACTION	
1	Is the delivery-sensing lever in the fuser assembly damaged or unable to move smoothly? (Due to wear, some delivery-sensing levers do not return to normal operating position after a page clears the fuser assembly.)	Yes	<u>Replace the delivery-sensing lever</u> or remove the obstruction.	
2	Remove the left contact cap from the fuser assembly and switch on the printer. Connect the multimeter across fuser PCA connector pins J331-6 and J331-7 (Figure 4-4). (The fuser PCA is the small circuit board attached to the fuser assembly. Connector J331 is the 7-pin connector on the board.)	Does the voltage change from +5 VDC to 0 VDC as you move the delivery sensor lever back and forth?	No Yes	<u>Replace the fuser assembly.</u> <u>Replace the cable that connects the DC controller to the fuser. If the problem persists, replace the DC controller PCA.</u>

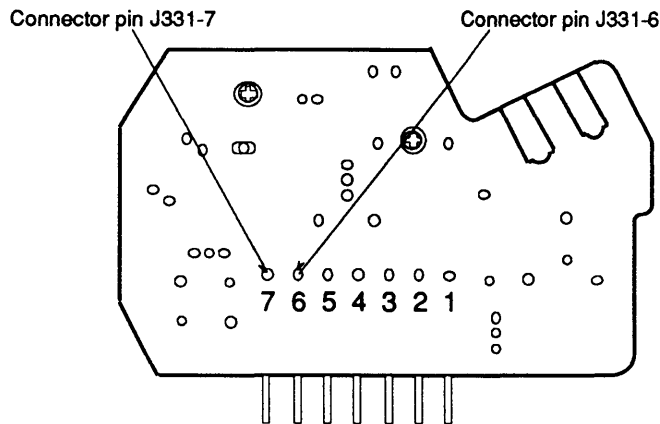

Figure 4-4 Fuser PCA Connector Pins

TABLE H—PAPER-OUT LED LIGHTS WHEN THERE IS PAPER

STEP	CHECK	RESULT	ACTION
1	Is the paper cassette installed?	No	Install the paper cassette.
2	Does it contain paper?	No	Load the cassette with paper.
3	Is the paper cassette seated properly?	No	Remove and reseat the paper cassette.
4	Is the paper cassette damaged?	Yes	Replace the paper cassette.
5	Does the paper-sensing arm move smoothly and fully travel? Is it undamaged?	No	Locate and correct the cause of the blockage or <u>replace the paper-sensing arm.</u>
6	Are the paper cassette microswitch actuator levers bent or broken?	Yes	Unbend the levers or replace them.
7	Are the paper cassette microswitches (SW202, SW202, or SW203) on the DC controller PCA damaged?	Yes	<u>Replace the DC controller PCA.</u>
8	When you remove and insert the paper cassette, does the voltage between DC controller connector J213-8 (PEMP*) and J213-6 (GND) toggle from +5 VDC (inserted) to 0 VDC (removed)?	No	<u>Replace the distribution PCA.</u>
		Yes	<u>Replace the DC controller PCA.</u>

□ TABLE I—PAPER-OUT LED DOESN'T LIGHT WITH NO PAPER

<i>STEP</i>	<i>CHECK</i>	<i>RESULT</i>	<i>ACTION</i>
1	Is the paper cassette seated properly?	No	Remove and reseal the paper cassette.
2	Is the paper cassette damaged?	Yes	Replace the paper cassette.
3	Does the paper-sensing arm move smoothly and fully travel? Is it undamaged?	No	Locate and correct the cause of the blockage or <u>replace the paper-sensing arm.</u>
4	Are the paper cassette microswitch actuator levers bent or broken?	Yes	Unbend the levers or replace them.
5	Are the paper cassette microswitches (SW202, SW202, or SW203) on the DC controller PCA damaged?	Yes	<u>Replace the DC controller PCA.</u>
6	When you remove and insert the paper cassette, does the voltage between DC controller connector J213-8 (PEMP*) and J213-6 (GND) toggle from +5 VDC (inserted) to 0 VDC (removed)?	No	<u>Replace the distribution PCA.</u>
		Yes	<u>Replace the DC controller PCA.</u>

□ TABLE J—PRECONDITIONING LAMPS DO NOT LIGHT

<i>STEP</i>	<i>CHECK</i>	<i>RESULT</i>	<i>ACTION</i>
1	Switch off the printer. Open the top cover and depress the top-cover interlock switch. Connect the multimeter to fuser PCA contacts J333 (+24 VDC) and J334 (GND). Switch on the printer.	Does the voltage rise from 0 to +24 VDC?	Yes <u>Replace the preconditioning exposure assembly.</u>
2	Switch off the printer and connect the multimeter to DC controller PCA connector pins J206-3 (PEXP) and J206-5 (GND). Switch on the printer.	Does the voltage change from 0 to +5 VDC?	Yes <u>Replace the fuser assembly.</u> No <u>Replace the DC controller PCA.</u>

□ TABLE K—LASER/SCANNER MALFUNCTION

<i>STEP</i>	<i>CHECK</i>	<i>RESULT</i>	<i>ACTION</i>
1	Are connectors J401 on the scanner motor PCA and J203 on the DC controller PCA properly seated?	No	Ensure that the connectors are properly seated.
2	Are connectors J451 on the laser driver PCA and J202 on the DC controller PCA properly seated?	No	Ensure that the connectors are properly seated.
3	Is the optical fiber cable between the laser/scanner assembly and J201 of the DC controller PCA correctly seated into each assembly?	No	Visually inspect the cable for damage and ensure that it is seated properly. Replace the cable if it is damaged.
4	Perform the "Laser Power Output Check" procedure in this section. Is the laser power output 17.6 mV (\pm 1.6 mV)?	No	<u>Replace the laser/scanner assembly.</u> If the problem remains, replace the laser harness cable.
		Yes	<u>Replace the DC controller PCA.</u>

□ TABLE L—ERRONEOUS LOW-TONER INDICATOR

Note: When you install a new toner cartridge in the LaserWriter II NT, the low-toner LED will remain on until the printer generates an engine self-test page or you switch the printer off and on.

STEP	CHECK	RESULT	ACTION
1	Does the toner cartridge have a drum-sensitivity cam?	No	Replace the toner cartridge.
2	Are the drum-sensitivity switches (SW301 and SW302) depressed when the toner cartridge is installed and the top cover is closed?	No	<u>Replace the distribution PCA.</u>
3	Connect the multimeter across DC controller pins J213-1 and J213-6. Open the top cover, depress the top cover interlock switch, and switch on the power. Does the voltage change from +5 VDC to 0 VDC when you depress switch SW301?	No	Verify that the distribution PCA is securely connected to DC controller PCA connector J213. If it is, <u>replace the distribution PCA.</u>
	Connect the multimeter across DC controller pins J213-2 and J213-6. Open the top cover, depress the top cover interlock switch, and switch on the power. Does the voltage change from +5 VDC to 0 VDC when you depress switch SW302?	No	Verify that the distribution PCA is securely connected to DC controller PCA connector J213. If it is, <u>replace the distribution PCA.</u>
4	Are the high-voltage power supply connector contacts clean?	No	Clean the high-voltage power supply contacts.
5	Are the high-voltage power supply contacts damaged?	Yes	<u>Replace the high-voltage power supply.</u>
		No	<u>Replace the DC controller PCA.</u>

□ **TABLE M—PRINT QUALITY PROBLEMS**

<i>STEP</i>	<i>CHECK</i>	<i>RESULT</i>	<i>ACTION</i>
1	Is the quality of the printout acceptable?	No	Compare the printout to the images shown in Figure 4-5 and then refer to the appropriate troubleshooting table.
2	Is the printout problem the result of a LaserWriter IIg (or LaserWriter IIx with 5 MB or more of RAM) that is unable to print in grayscale?	Yes	Refer to Table M23 in this section.



<p>Light Image</p>  <p>Go to Table M1</p>	<p>Faded Print</p>  <p>Go to Table M1</p>	<p>Dark Image</p>  <p>Go to Table M2</p>	<p>All-Blank Print</p>  <p>Go to Table M3</p>	<p>Black Image</p>  <p>Go to Table M4</p>
<p>Stained Print</p>  <p>Go to Table M5</p>	<p>Repetitive Defects</p>  <p>Go to Table M5</p>	<p>Black Image with Horizontal White Stripes</p>  <p>Go to Table M6</p>	<p>Stains on Back of Paper</p>  <p>Go to Table M7</p>	<p>Dark Vertical Lines</p>  <p>Go to Table M8</p>
<p>Sharp Horizontal Black Lines</p>  <p>Go to Table M9</p>	<p>Vertical Fogged Stripes</p>  <p>Go to Table M10</p>	<p>Horizontal Fogged Stripes</p>  <p>Go to Table M11</p>	<p>Blank Spots</p>  <p>Go to Table M12</p>	<p>Thin Vertical White Lines/Stripes</p>  <p>Go to Table M13</p>
<p>Faulty Registration</p>  <p>Go to Table M14</p>	<p>Poor Fusing</p>  <p>Go to Table M15</p>	<p>Distortion</p>  <p>Go to Table M16</p>	<p>Waviness</p>  <p>Go to Table M17</p>	<p>Uneven Print Density</p>  <p>Go to Table M18</p>
<p>Foggy Print</p>  <p>Go to Table M19</p>	<p>Horizontal Bonding</p>  <p>Go to Table M20</p>	<p>Wavy Print on Gray</p>  <p>Go to Table M21</p>	<p>Blotchy Printing</p>  <p>Go to Table M22</p>	<p>Ghosting</p>  <p>Go to Table M22</p>

Figure 4-5 Print Quality Problems

□ TABLE M1—LIGHT IMAGE/FADED PRINT: WHOLE PRINT (1 of 3)

STEP	CHECK	RESULT	ACTION
1	Turn the print density adjustment dial up one number. Does the print quality improve?	Yes	Finished.
2	Is the Low-Toner LED on the status panel on?	Yes	Install a new Apple toner cartridge.
3	Is the toner cartridge new?	Yes	Hold the toner cartridge lengthwise and rock it from side to side three or four times.
4	Has the installed toner cartridge been refilled?	Yes	Replace the toner cartridge with a new Apple toner cartridge.
5	Do prints improve when you use new paper?	Yes	Replace with the type of paper recommended for the particular print job. See Section 1, Basics, "Specifications," for recommended paper.
6	Is the transfer corona wire dirty or broken?	Yes	Clean or <u>replace the transfer corona wire</u> .

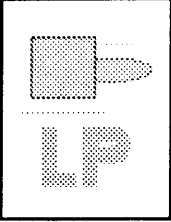
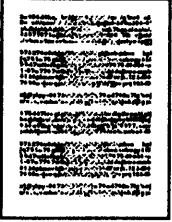
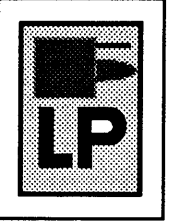
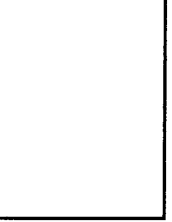
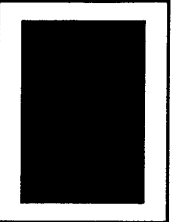
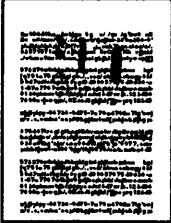
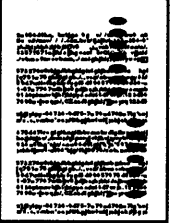
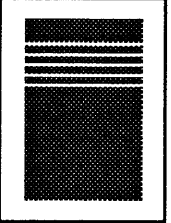
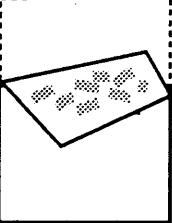
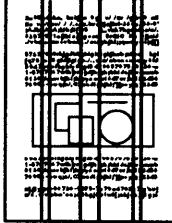
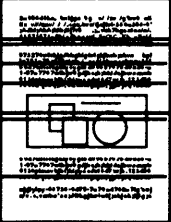
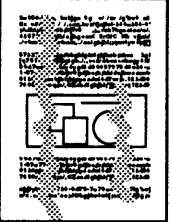
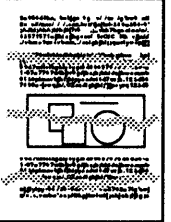
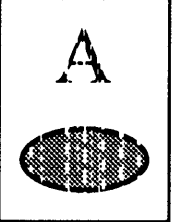
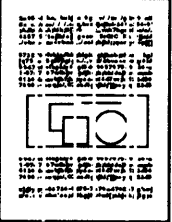
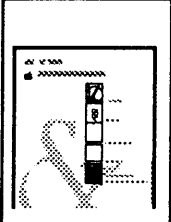
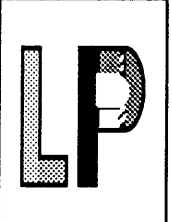
For steps 7 and 8, you must remove the controller-I/O board, cover set, bottom panel, and lower cover. Install a toner cartridge.

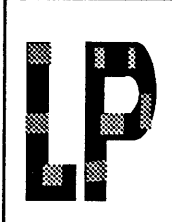
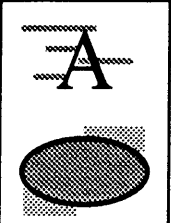
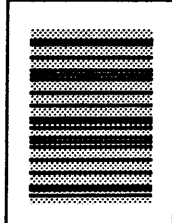
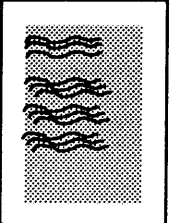
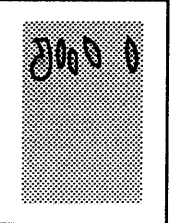
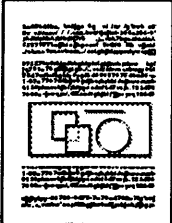
7	Perform the following tests to verify the operation of the drum-sensitivity switches: Connect the multimeter across DC controller pins J213-1 (CSENS1) and J213-6 (GND). Open the top cover, depress the top-cover interlock, and switch on the power. Does the voltage drop from +5 VDC to 0 VDC when you depress drum-sensitivity switch SW301?	No	Verify that the distribution PCA is securely connected to DC PCA connector J213. If it is, <u>replace the distribution PCA</u> .
---	--	----	--

...Continued on next page

□ TABLE M1—LIGHT IMAGE/FADED PRINT: WHOLE PRINT (2 of 3)

STEP	CHECK	RESULT	ACTION
	Connect the multimeter across DC controller pins J213-2 (CSENS2) and J213-6 (GND). Open the top cover, depress the top-cover interlock, and switch the power on. Does the voltage drop from +5 VDC to 0 VDC when you depress drum-sensitivity switch SW302?	No	Verify that the distribution PCA is securely connected to DC controller PCA connector J213. If it is, <u>replace the distribution PCA.</u>
8	Perform the following test to verify the operation of the high-voltage power supply and the DC controller PCA:		
	Connect the multimeter across high-voltage power supply pins J601-1 (HVTON) and J601-7 (GND). Press the engine self-test switch. Does the voltage drop from 20-24 VDC to 0 VDC one second after the print cycle begins?	No	Verify that the high-voltage power supply cable is securely attached to DC controller connector J211. If it is, <u>replace the DC controller PCA.</u>
	Connect the multimeter across high-voltage power supply pins J601-6 (DBDC) and J601-7 (GND). Press the engine self-test switch. Does the voltage drop from 16–20 VDC to 0 VDC one second after the print cycle begins?	No	Verify that the high-voltage power supply cable is securely attached to DC controller connector J211. If it is, <u>replace the DC controller PCA.</u>
	Connect the multimeter across high-voltage power supply pins J601-4 (DBAC) and J601-7 (GND) Press the engine self-test switch. Does the voltage drop from 16–20 VDC to 0 VDC one second after the print cycle begins?	No	Verify that the high-voltage power supply cable is securely attached to DC controller connector J211. If it is, <u>replace the DC controller PCA.</u>

□ TABLE M1—LIGHT IMAGE/FADED PRINT: WHOLE PRINT (3 of 3)

<i>STEP</i>	<i>CHECK</i>	<i>RESULT</i>	<i>ACTION</i>
9	Try printing again. Has the print quality improved?	Yes	Finished.
		No	<u>Replace the high-voltage power supply.</u>
10	Try printing again. Has the print quality improved?	Yes	Finished.
		No	<u>Replace the laser/scanner assembly.</u>

□ TABLE M2—DARK IMAGE: WHOLE PRINT

STEP	CHECK	RESULT	ACTION
1	Turn the print density adjustment dial down one number.		
	Does the print quality improve?	Yes	Finished.
2	Perform the following tests to verify the operation of the drum-sensitivity switches:		
	Connect the multimeter across DC controller connector pins J213-1 (CSENS1*) and J213-6 (GND). Open the top cover, depress the top-cover interlock switch, and switch the power on. Does the voltage drop from +5 VDC to 0 VDC when you depress drum-sensitivity switch SW301?	No	Verify that the distribution PCA is securely connected to DC controller PCA connector J213. If it is, <u>replace the distribution PCA.</u>
	Connect the multimeter across DC controller connector pins J213-2 (CSENS2*) and J213-6 (GND). Open the top cover, depress the top-cover interlock switch, and switch the power on. Does the voltage drop from +5 VDC to 0 VDC when you depress drum-sensitivity switch SW302?	No	Verify that the distribution PCA is securely connected to DC controller PCA connector J213. If it is, <u>replace the distribution PCA.</u>
3	Is the toner cartridge grounding spring TB602 on the high-voltage power supply making good contact with the toner cartridge, and is the spring clean?	No	If the grounding spring is dirty, clean it. If the spring is damaged, <u>replace the high-voltage power supply.</u>
4	<u>Replace the laser/scanner assembly.</u>		
	Does the print quality improve?	Yes	Finished.
		No	Replace the laser harness cable. If the problem remains, <u>replace the DC controller PCA.</u>

□ TABLE M3—ALL-BLANK PRINT (1 of 2)

STEP	CHECK	RESULT	ACTION
1	Is the Low-Toner LED on the status panel on?	Yes	Replace the toner cartridge.
2	Are the Paper-Out and Paper-Jam LEDs flashing?	Yes	<u>Replace the laser/scanner assembly.</u>
3	Have you removed the toner cartridge sealing tape?	No	Remove the sealing tape.
4	Do the toner cartridge protective shield and laser blocking shutters open and close smoothly? Are all the above parts undamaged?	No	Replace the toner cartridge.
5	<u>Temporarily remove the shutter assembly</u> that covers the mirror assembly and initiate a test print. Is the print quality good?	Yes	<u>Install a new shutter assembly.</u>
6	Is the transfer corona wire broken?	Yes	<u>Replace the transfer corona wire.</u>
7	Are connectors J401 on the scanner motor PCA and J203 on the DC controller PCA properly seated?	No	Ensure that the connectors are properly seated.
8	Are connectors J451 on the laser driver PCA and J202 on the DC controller PCA properly seated?	No	Ensure that the connectors are properly seated.
9	Perform the Laser Power Output Check procedure later in this section. Does the laser power output measure 17.6 ± 1.6 mV?	No	<u>Replace the laser/scanner assembly.</u> If the problem persists, replace the laser harness cable.
		Yes	<u>Replace the DC controller PCA.</u>

...Continued on next page

□ TABLE M3—ALL-BLANK PRINT (2 of 2)

STEP	CHECK	RESULT	ACTION
	<p>For steps 10 and 11, you must <u>remove the controller-I/O board, cover set, bottom panel, and lower cover</u>. Install a toner cartridge and close the top cover. Be sure to defeat the interlock switch (part of the DC controller) on the bottom of the printer.</p>		
10	<p>Connect the multimeter across high-voltage power supply connector pins J601-6 (DBDC*) and J601-7 (GND). Initiate an engine self-test page. Does the voltage change from +16 VDC to 0 VDC one second after the main motor starts to rotate?</p>	No	<p>Replace the cable from the DC controller to the high-voltage power supply. If the problem remains, <u>replace the DC controller PCA</u>.</p>
11	<p>Connect the multimeter across high-voltage power supply connector pins J601-4 (DBAC*) and J601-7 (GND). Initiate an engine self-test page. Does the voltage change from +16 VDC to 0 VDC one second after the print cycle begins?</p>	No	<p>Replace the cable from the DC controller to the high-voltage power supply. If the problem remains, <u>replace the DC controller PCA</u>.</p>
12	<p>Try printing again. Has the print quality improved?</p>	Yes	Finished.
		No	<u>Replace the high-voltage power supply.</u>
13	<p>Try printing again. Has the print quality improved?</p>	Yes	Finished.
		No	<u>Replace the laser/scanner assembly.</u>

□ TABLE M4—BLACK IMAGE

<i>STEP</i>	<i>CHECK</i>	<i>RESULT</i>	<i>ACTION</i>
1	Is the toner cartridge properly seated?	No	Reinstall the toner cartridge.
2	Is the primary corona wire inside the toner cartridge broken?	Yes	Replace the toner cartridge.
3	<u>Remove the high-voltage power supply</u> , install a toner cartridge, and close the top cover. Connect the multimeter across high-voltage power supply connector pins J601-3 (HV10N) and J601-7 (GND). Switch on the printer.		
	Does the voltage drop from +16 VDC to 0 VDC one second after the main motor starts to rotate?	Yes	Verify that high-voltage connector pin TB603-2 is making good contact with the toner cartridge primary corona. If it is, <u>replace the high-voltage power supply</u> .
		No	Verify that the high-voltage power supply cable is securely attached to DC controller PCA connector J211. If it is, <u>replace the DC controller PCA</u> .

□ TABLE M5—STAINED PRINT/REPETITIVE DEFECTS

<i>STEP</i>	<i>CHECK</i>	<i>RESULT</i>	<i>ACTION</i>
1	Do prints improve when you use new paper?	Yes	Replace with the type of paper recommended for the particular print job. See Section 1, Basics, "Specifications," for recommended paper.
2	Is the wrong side of the paper being used?	Yes	Turn the paper over in order to print on the correct side.
3	Is the fuser roller cleaner felt dirty?	Yes	Replace the cleaner felt.
4	Visually inspect the transfer guide assembly. Is the collar at the end of the roller shaft pointing away from the transfer corona?	No	Install the transfer guide so that the collar at the end of the roller shaft points away from the transfer corona.
	Does the print image improve?	Yes	Finished.
5	Are the pickup rollers dirty?	Yes	Clean the pickup rollers.
6	Is the toner cartridge damaged?	Yes	<u>Replace the toner cartridge.</u>
7	Is the high-voltage power supply connection to the discharging pins clean and undamaged?	No	Clean the contact or <u>replace the high-voltage power supply.</u>

□ TABLE M6—BLACK IMAGE & HORIZONTAL WHITE STRIPES

STEP	CHECK	RESULT	ACTION
1	Is the optical fiber cable damaged or broken?	Yes	Replace the optical fiber cable.
2	<u>Replace the laser/scanner assembly.</u>		
	Does the print quality improve?	Yes	Finished.
		No	Replace the laser harness cable. If the problem remains, <u>replace the DC controller PCA.</u>

□ TABLE M7—STAINS ON BACK OF PAPER

STEP	CHECK	RESULT	ACTION
1	Is the fuser roller cleaner felt dirty?	Yes	Replace the cleaner felt.
2	Are any of the following components dirty? a) Paper cassette or its cover b) Transfer guide assembly c) Transfer corona assembly d) Feeder assembly e) Fuser assembly	Yes	Clean with a damp cloth, then with a dry cloth.
3	Visually inspect the transfer guide assembly. Is the collar at the end of the roller shaft pointing away from the transfer corona?	No	Install the transfer guide so that the collar at the end of the roller shaft points away from the transfer corona.
	Does the print image improve?	Yes	Finished.

□ TABLE M8—DARK VERTICAL LINES

<i>STEP</i>	<i>CHECK</i>	<i>RESULT</i>	<i>ACTION</i>
1	Is the fuser roller cleaner felt dirty?	Yes	Replace the cleaner felt.
2	Clean the primary corona wire inside the toner cartridge.		
	Does the print image improve?	Yes	Finished.
3	Do the dark vertical lines appear on the print engine test page?	No	<u>Replace the controller-I/O board.</u>
4	Clean the transfer corona wire.		
	Does the print image improve?	Yes	Finished.
5	Replace the toner cartridge.		
	Does the print image improve?	Yes	Finished.

□ TABLE M9—SHARP HORIZONTAL BLACK LINES

<i>STEP</i>	<i>CHECK</i>	<i>RESULT</i>	<i>ACTION</i>
-	<u>Replace the laser/scanner assembly.</u>		
	Does the print image improve?	Yes	Finished.
		No	Replace the laser harness cable. If the problem remains, <u>replace the DC controller PCA.</u>

□ TABLE M10—VERTICAL FOGGED STRIPES

STEP	CHECK	RESULT	ACTION
1	<u>Remove the shutter assembly</u> and inspect the mirror located beneath the shutter assembly. Is the mirror dirty?	Yes	Clean the mirror assembly.
	Does the print image improve?	Yes	Finished.
2	Clean the primary corona wire inside the toner cartridge.		
	Does the print image improve?	Yes	Finished.
3	Replace the toner cartridge with a new Apple toner cartridge.		
	Does the print image improve?	Yes	Finished.
4	Visually inspect the high-voltage power supply. Are all four of the Phillips screws installed?	No	Install the four Phillips screws that secure the high-voltage power supply to the printer.
	Does the print image improve?	Yes	Finished.
5	Visually inspect the transfer guide assembly. Is the collar at the end of the roller shaft pointing away from the transfer corona?	No	Install the transfer guide so that the collar at the end of the roller shaft points away from the transfer corona.
	Does the print image improve?	Yes	Finished.

□ TABLE M11—HORIZONTAL FOGGED STRIPES

STEP	CHECK	RESULT	ACTION
1	<u>Replace the toner cartridge.</u>		
	Does the print image improve?	Yes	Finished.
2	Replace the fuser roller cleaner felt.		
	Does the print image improve?	Yes	Finished.
3	Do the horizontal fogged stripes appear on the bottom third of the page?	Yes	Replace the paper fuser guide.
	Does the print quality improve?	Yes	Finished.
		No	<u>Replace the fuser assembly.</u>

□ TABLE M12—BLANK SPOTS

STEP	CHECK	RESULT	ACTION
1	Are you using the type of paper recommended for the print job?	No	Replace with recommended paper. See Section 1, Basics, "Specifications," for recommendations.
2	Is the paper damp?	Yes	Replace the paper. Instruct the user to store paper in its package in a dry place and not to open the packages until necessary.
3	Is the wrong side of the paper being used?	Yes	Turn the paper over in order to print on the correct side.
4	Is the Low-Toner LED on the status panel on?	Yes	Install a new Apple toner cartridge.
5	Has the installed toner cartridge been refilled?	Yes	Install a new Apple toner cartridge.
6	Turn the print density adjustment dial up one number. Does the print quality improve?	Yes	Finished.

□ TABLE M13—THIN VERTICAL WHITE LINES OR STRIPES

<i>STEP</i>	<i>CHECK</i>	<i>RESULT</i>	<i>ACTION</i>
1	Hold the toner cartridge lengthwise and rock it from side to side three or four times.		
	Does the print image improve?	Yes	Finished.
2	<u>Remove the shutter assembly</u> and inspect the mirror assembly.		
	Is the mirror dirty?	Yes	Clean the mirror assembly.
3	Is the transfer corona wire or assembly dirty?	Yes	Clean the transfer corona wire and assembly.

□ TABLE M14—FAULTY REGISTRATION

STEP	CHECK	RESULT	ACTION
1	Does the paper cassette have too much paper (i.e., more than 200 sheets)?	Yes	Remove excess paper.
2	Do you have the recommended paper for the print job?	No	Replace with recommended paper. See Section 1, Basics, "Specifications," for recommendations.
3	Are the pickup rollers dirty, worn, or damaged?	Yes	Clean or <u>replace the pickup rollers</u> .
4	Is the registration roller clutch spring deformed or broken?	Yes	<u>Replace the transfer guide assembly</u> .
5	Are the paper cassette microswitches—SW201, SW202, and SW203—bent or damaged? (To locate the microswitches, you must remove the paper cassette.)	Yes	<u>Replace the DC controller PCA</u> . (The microswitches are wired to the DC controller PCA.)
6	For this step, you must <u>remove the controller-I/O board, cover set, bottom panel, and lower cover</u> . Install a toner cartridge and close the top cover. Connect the multimeter across DC controller PCA connector pins J213-3 (REGD) and J213-6 (GND). Initiate an engine self-test page.		
	Does the voltage across DC controller PCA connector pins J231-3 (REGD) and J213-6 (GND) rise from 0 VDC to +5 VDC three seconds after the main motor starts to rotate?	Yes	<u>Replace the distribution PCA</u> .
		No	<u>Replace the DC controller PCA</u> .

□ TABLE M15—POOR FUSING: IMAGE SMEARS EASILY

<i>STEP</i>	<i>CHECK</i>	<i>RESULT</i>	<i>ACTION</i>
1	Do you have the recommended paper for the print job?	No	Replace with recommended paper. See Section 1, Basics, "Specifications," for recommendations.
2	Are the upper or lower fuser rollers worn?	Yes	<u>Replace the fuser assembly.</u>
3	Is the fuser assembly warm?	No	Refer to Table D—Heater Bulb Does Not Operate.

□ TABLE M16—DISTORTION

<i>STEP</i>	<i>CHECK</i>	<i>RESULT</i>	<i>ACTION</i>
—	Perform an engine self-test and observe LED 201 on the DC controller.		
	Does LED 201 stay on steadily without flashing during the print process?	No	Perform each of the following actions. Initiate an engine self-test page after each step to see if the problem is solved: a) Inspect all parts of the paper transport system. b) <u>Replace the laser/ scanner assembly.</u> c) <u>Replace the DC controller PCA.</u>

□ TABLE M17—WAVINESS

<i>STEP</i>	<i>CHECK</i>	<i>RESULT</i>	<i>ACTION</i>
1	Perform an engine self-test and observe LED 201 on the DC controller PCA. Does LED 201 stay on steadily without flashing during the print process?	No	<u>Replace the laser/scanner assembly.</u>
2	Initiate another engine self-test page. Does the print quality improve?	Yes	Finished.
		No	Reinstall the original laser/scanner assembly and replace the laser harness cable. If the problem remains, <u>replace the DC controller PCA.</u>

□ TABLE M18—UNEVEN PRINT DENSITY

<i>STEP</i>	<i>CHECK</i>	<i>RESULT</i>	<i>ACTION</i>
1	Hold the toner cartridge lengthwise and rock it from side to side three or four times to distribute the toner evenly.		
		Does the print quality improve?	Yes
2	Is the upper transfer guide or transfer guide bent?	Yes	<u>Replace the upper transfer guide or transfer guide.</u>

□ TABLE M19—FOGGY PRINT

<i>STEP</i>	<i>CHECK</i>	<i>RESULT</i>	<i>ACTION</i>
1	Do prints improve when you use new paper?	Yes	Replace with the type of paper recommended for the particular print job. See Section 1, Basics, "Specifications," for recommendations.
2	Has the installed toner cartridge been refilled?	Yes	Install a new Apple toner cartridge.
3	Is the fuser roller cleaner felt dirty?	Yes	Replace the cleaner felt.
4	Are the pickup rollers dirty?	Yes	Clean the pickup rollers.
5	Adjust the print density slide.		
	Does the print quality improve?	Yes	Finished.

□ TABLE M20—HORIZONTAL BANDING

<i>STEP</i>	<i>CHECK</i>	<i>RESULT</i>	<i>ACTION</i>
1	Is the Low-Toner LED on the status panel on?	Yes	Install a new Apple toner cartridge.
2	Has the installed toner cartridge been refilled?	Yes	Install a new Apple toner cartridge.
3	Is the fuser roller cleaner felt dirty?	Yes	Replace the cleaner felt.
4	Are the pickup rollers dirty?	Yes	Clean the pickup rollers.
5	Adjust the print density slide.		
	Does the print quality improve?	Yes	Finished.

□ TABLE M21—WAVY PRINT ON GRAY

<i>STEP</i>	<i>CHECK</i>	<i>RESULT</i>	<i>ACTION</i>
1	Is the Low-Toner LED on the status panel on?	Yes	Install a new Apple toner cartridge.
2	Is the toner cartridge new?	Yes	Hold the toner cartridge lengthwise and rock it from side to side three or four times.
3	Has the installed toner cartridge been refilled?	Yes	Replace the toner cartridge with a new Apple toner cartridge.

□ TABLE M22—BLOTCHY OR GHOSTING PRINTING

<i>STEP</i>	<i>CHECK</i>	<i>RESULT</i>	<i>ACTION</i>
—	Did the problem occur on the first drum rotation of the photodrum?	Yes	Move your printed image below the 94 mm mark from the top of page and reprint the page.

**□ TABLE M23—IMAGE DOES NOT PRINT IN GRAYSCALE
(LaserWriter IIf and IIg only)**

<i>STEP</i>	<i>CHECK</i>	<i>RESULT</i>	<i>ACTION</i>
1	Have you selected the Color/Grayscale option in the Print dialog box?	No	Open the Print dialog box and select the Color/Grayscale option.
2	Does the printer have at least 5 MB of RAM on the controller-I/O board?	No	Install additional RAM on the controller-I/O board.
3	Was the toner cartridge refilled?	Yes	Install a new Apple toner cartridge.
4	Is the controller-I/O board defective?	Yes	<u>Replace the controller-I/O board.</u>

□ TABLE N—PAPER TRANSPORT PROBLEMS

STEP	CHECK	RESULT	ACTION
–	Perform an engine self-test. If the paper jams, open the printer and observe the location of the paper.		
1)	Did the printer take paper from the cassette?	No	Go to "Table N1—No Paper Pickup."
2)	Is the paper jam in the paper pickup or transfer guide area?	Yes	Go to "Table N2—Jams in Pickup/Transfer Area."
3)	Is the paper jam in the separation or feeder guide area?	Yes	Go to "Table N3—Jams in Separation/Feeder Guide Area."
4)	Is the paper jam in the fuser or delivery area?	Yes	Go to "Table N4—Jams in Fuser/Delivery Area."
5)	Are sheets of paper stuck together in the paper path?	Yes	Go to "Table N5—Sheets Stuck Together."
6)	Is the paper wrinkled?	Yes	Go to "Table N6—Wrinkles."

□ TABLE N1—NO PAPER PICKUP

STEP	CHECK	RESULT	ACTION
1	Open the top cover. Is a piece of paper stuck in the printer?	Yes	Remove the paper.
2	Switch on the printer and observe the delivery rollers in the top unit.		
	Do the rollers rotate for a few seconds as the main motor finds home position?	No	Go to "Table B—Delivery Rollers Do Not Rotate."
3	Connect the multimeter to DC controller PCA connector pins J213-4 (CPUD) and J213-6 (GND). Perform an engine self-test.		
	Does the voltage change from 0 VDC to approximately +5 VDC two seconds after the main motor starts to rotate?	Yes	<u>Replace the distribution PCA.</u>
		No	<u>Replace the DC controller PCA.</u>

□ TABLE N2—JAMS IN PICKUP/TRANSFER AREA (1 of 2)

STEP	CHECK	RESULT	ACTION
1	Are you using the type of paper recommended for the print job?	No	Replace with recommended paper. See Section 1, Basics, "Specifications," for recommendations.
2	Is the paper wrinkled or curled?	Yes	Use fresh paper.
3	Is the paper cassette loaded with too much paper (> 200 sheets)?	Yes	Remove excess paper.
4	Is the paper cassette installed properly in the printer?	No	Reinstall the paper cassette properly.
5	Are the paper cassette springs damaged?	Yes	Replace the paper cassette.
6	Is the pick-up roller dirty, worn, or damaged?	Yes	Clean the pickup roller with alcohol. If the roller is worn or damaged, replace the pickup roller.
7	Is the registration roller clutch spring deformed or broken?	Yes	<u>Replace the transfer guide assembly.</u>
8	Is the upper transfer guide bent?	Yes	<u>Replace the transfer guide assembly.</u>

□ TABLE N2—JAMS IN PICKUP/TRANSFER AREA (2 of 2)

<i>STEP</i>	<i>CHECK</i>	<i>RESULT</i>	<i>ACTION</i>
9	Connect the multimeter to DC controller PCA connector pins J213-4 (CPUD) and J213-6 (GND). Perform an engine self-test.		
	Does the voltage change from 0 VDC to approximately +5 VDC two seconds after the main motor starts to rotate?	Yes	<u>Replace the distribution PCA.</u>
10	Connect the multimeter to DC controller PCA connector pins J213-3 (REGD) and J213-6 (GND). Perform an engine self-test.	No	<u>Replace the DC controller PCA.</u>
	Does the voltage change from 0 VDC to approximately +5 VDC two seconds after the main motor starts to rotate?	Yes	<u>Replace the distribution PCA.</u>
		No	<u>Replace the DC controller PCA.</u>

□ TABLE N3—JAMS IN SEPARATION/FEEDER GUIDE AREA

<i>STEP</i>	<i>CHECK</i>	<i>RESULT</i>	<i>ACTION</i>
-	Clean the connection between the discharging pins and the high-voltage power supply.		
	Do the paper jams continue?	No	Finished.
		Yes	<u>Replace the high-voltage power supply.</u>

□ TABLE N4—JAMS IN FUSER/DELIVERY AREA

STEP	CHECK	RESULT	ACTION
1	Is the fuser roller cleaner felt dirty?	Yes	Replace the cleaner felt.
2	Are the upper or lower paper guides dirty?	Yes	Clean the guides as described in Section 5, Preventive Maintenance.
3	Are any of the separation claws dirty, worn, or damaged?	Yes	Clean the separation claws as described in Section 5, Preventive Maintenance, or <u>replace the claws as necessary.</u>
4	Is the paper delivery-sensing lever in the fuser assembly damaged or broken?	Yes	<u>Replace the delivery sensing lever.</u>
5	Is the new version of the delivery-sensing lever installed? (Refer to Take-Apart, Delivery Sensing Lever.)	No	<u>Replace the delivery sensing lever.</u>
6	Is the fuser assembly defective?	No	<u>Replace the fuser assembly.</u>
7	Are the delivery rollers worn or damaged?	Yes	<u>Replace the delivery rollers, or replace the fuser assembly.</u>

□ TABLE N5—SHEETS STUCK TOGETHER

STEP	CHECK	RESULT	ACTION
1	Are you using the type of paper recommended for the print job?	No	Replace with recommended paper. See Section 1, Basics, "Specifications," for recommendations.
2	Are the paper cassette springs damaged?	Yes	Replace the paper cassette.
		No	<u>Replace the separation pad.</u>

□ TABLE N6—WRINKLES

STEP	CHECK	RESULT	ACTION
1	Are you using the type of paper recommended for the print job?	No	Replace with recommended paper. See Section 1, Basics, "Specifications," for recommendations.
2	Install fresh paper in the paper cassette. Does the wrinkling stop?	Yes	Finished.
		No	Replace the cassette tray.
3	Perform an engine self-test and open the top cover while the paper passes over the feeder guide (about 5 seconds after paper pickup).		
	Is the paper wrinkled?	Yes	Check that the pickup and registration rollers are clean and undamaged. If the rollers cannot be cleaned or are damaged, <u>replace the pickup roller(s) or transfer guide assembly</u> , respectively.
		No	Clean the fuser assembly as described in Section 5, Preventive Maintenance.

□ TABLE O—NT/NTX ROM AND SIMM TEST

<i>STEP</i>	<i>CHECK</i>	<i>RESULT</i>	<i>ACTION</i>
1	Run the NT/NTX ROM and SIMM Test. (For information on setting up and running the test, refer to Section 7, Diagnostics.)		
2	Was the NT/NTX ROM and SIMM Test able to communicate with the LaserWriter II?	No	Verify that the serial port cable and test connector are installed, and rerun the test.
3	Did the test display the "All Tests Passed" message?	No	Replace the failed module and rerun the test.
		Yes	Finished.

□ LASER POWER OUTPUT CHECK

There is no adjustment available in the LaserWriter II laser power circuitry. However, when troubleshooting, you may have to verify the power output of the laser diode.

Equipment Required

Laser Power Checker
Digital Voltmeter

Procedure

1. Switch the printer power to OFF.
2. Remove the controller-I/O board and the cover set.
3. With the printer power off, open the laser access hatch on the laser/scanner assembly (**Figure 4-6**).

WARNING: Do not open the laser access hatch or disconnect the optical fiber cable when the printer is switched on. The reflected laser beam, though invisible, can permanently damage your eyes.

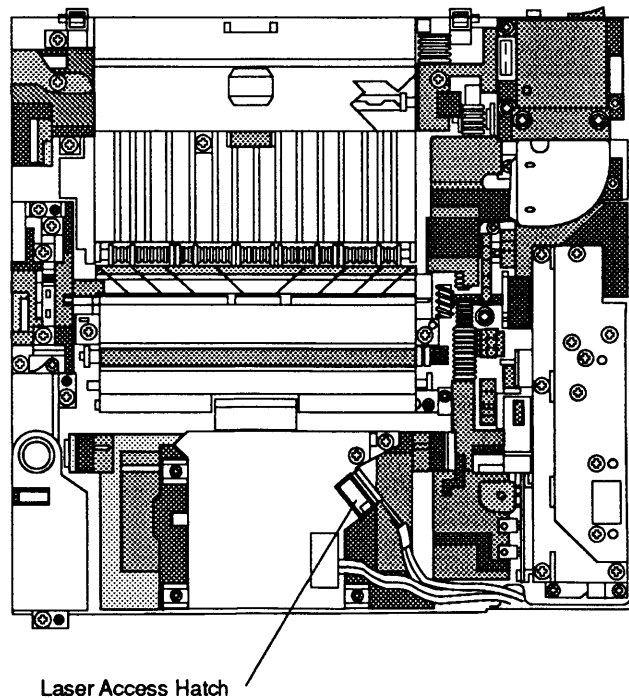

Figure 4-6 Laser Access Hatch

4. Insert the laser power checker into the laser access hatch with the detector facing the laser diode (**Figure 4-7**).

WARNING: Make sure the laser power checker is fully inserted so that none of the laser light can escape from the access hatch.

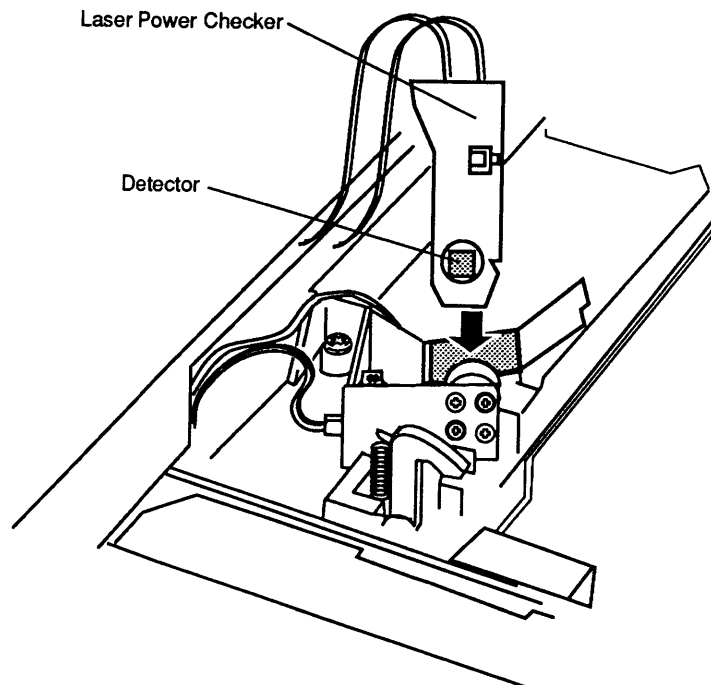

Figure 4-7 Inserting the Laser Power Checker

5. Connect the laser power checker to the digital voltmeter as follows:
 - a) Connect the black lead from the laser power checker to the multimeter socket labeled "Common."
 - b) Connect the red lead from the checker to the multimeter socket marked "Volts" or "V."
 - c) Set the multimeter to Volts, set the range to 200 mV, and switch the multimeter on.
6. Defeat the top-cover interlock switch by inserting a nonmetallic tool into the opening (**Figure 4-8**).

7. Switch the printer power to ON and wait one minute for the printer to warm up.
8. Depress drum-sensitivity microswitches SW301 and SW302 (**Figure 4-8**), which are just below the cover interlock switch. With switches SW301 and SW302 depressed, press the engine self-test switch.

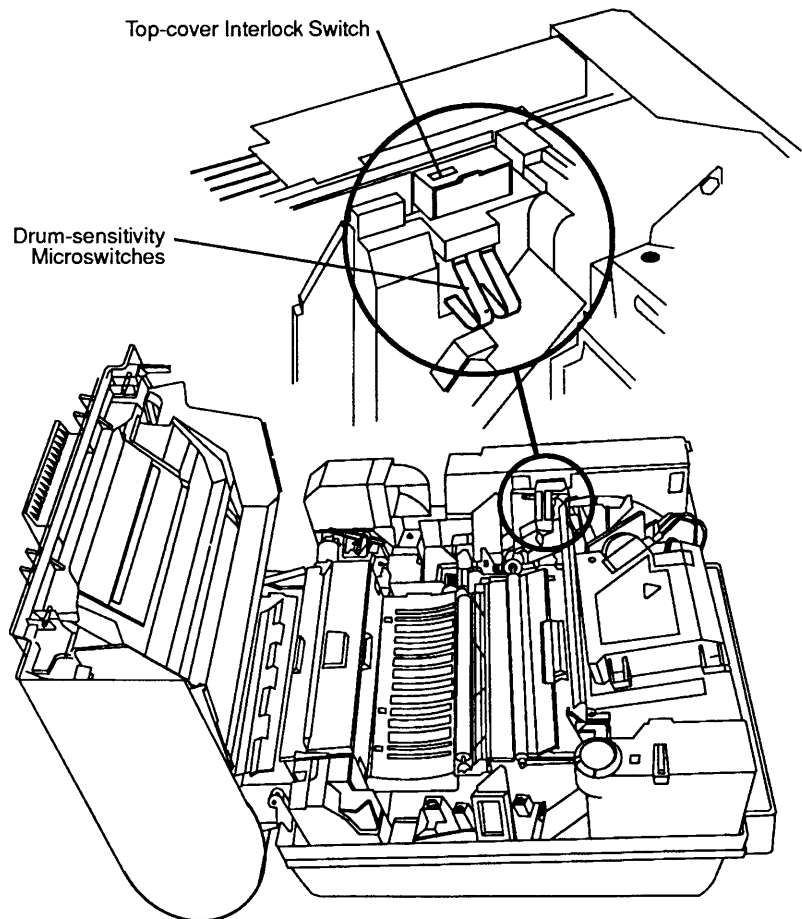

Figure 4-8 Bypassing Top-Cover Interlock Switch

9. Verify that the laser power output reading on the multimeter is 17.6 ± 1.6 mV.
 - a) If you cannot measure the laser power, replace the laser/scanner assembly and repeat steps 4 through 9.
 - b) If you still cannot measure the laser power, replace the DC controller PCA.

□ DC CONTROLLER PCA SWITCHES AND CONNECTORS

The following diagram (**Figure 4-9**) illustrates the DC controller PCA switches and connectors.

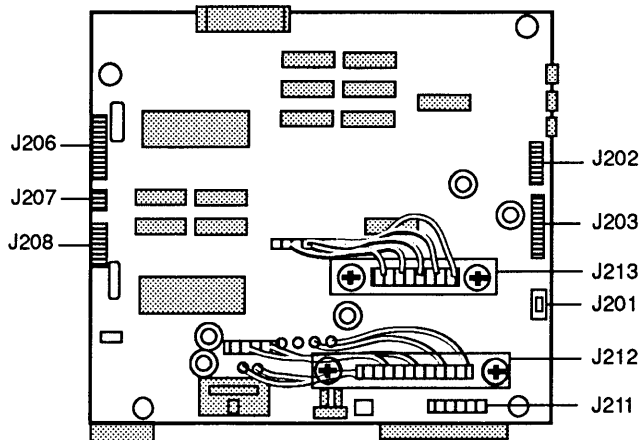

Figure 4-9 DC Controller PCA Switches and Connectors

□ HIGH-VOLTAGE POWER SUPPLY CONNECTOR CONTACTS

The following diagram (**Figure 4-10**) illustrates the high-voltage power supply connector contacts.

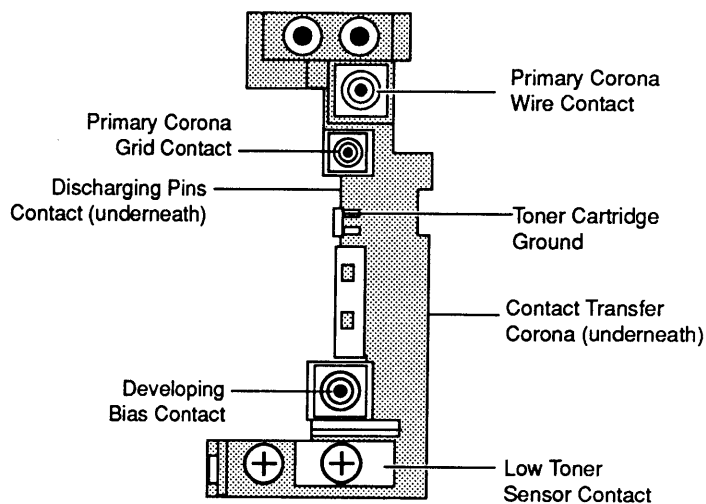

Figure 4-10 High-Voltage Power Supply Connector Contacts

□ DISTRIBUTION PCA SENSORS, SWITCHES, and SOLENOIDS

The following diagram (**Figure 4-11**) illustrates the distribution PCA sensors, switches, and solenoids.

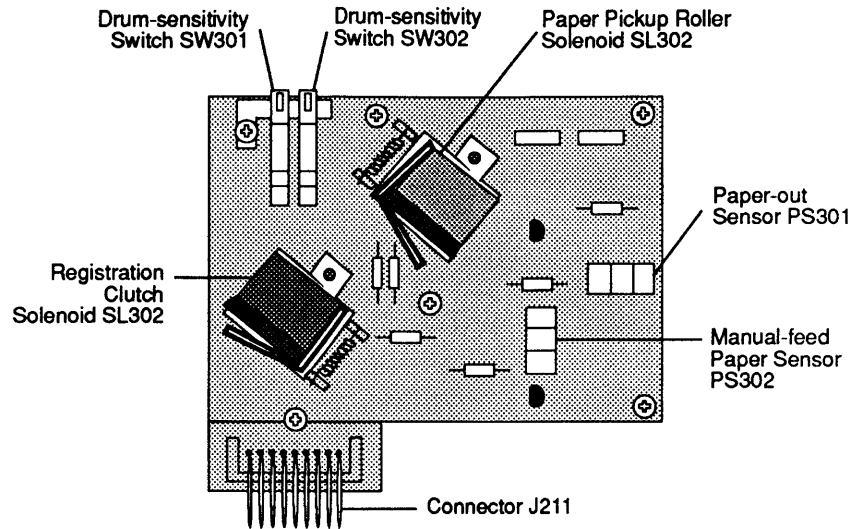

Figure 4-11 Distribution PCA Sensors, Switches, and Solenoids



)

)

)



LaserWriter II

Section 5 – Preventive Maintenance

□ CONTENTS

5.3	Introduction
5.3	Before Beginning
5.3	Safety
5.3	Electrostatic Discharge Precautions
5.4	Setup
5.5	Repair Log Label
5.6	Maintenance Schedule
5.6	Schedule
5.7	Checking the Print Count
5.8	End-User Maintenance
5.8	Cleaning Procedures
5.8	Case
5.8	Primary Corona Wire
5.9	Transfer Corona Wire
5.9	Transfer Guide Assembly
5.10	Discharging Pins
5.10	Fuser Rollers
5.11	Standard Maintenance
5.11	Cleaning Procedures
5.11	Separation Claws
5.12	Paper Guides
5.12	Lower Delivery Guide
5.13	Transfer Corona Assembly
5.13	Registration Rollers
5.14	Feeder Guide
5.14	Replacing the Ozone Filter
5.14	Update the Repair Log
5.15	100,000-Copy Maintenance
5.15	Procedure

Note: If a step is underlined, instructions for that step can be found in Section 2, Take-Apart.



□ INTRODUCTION

Before Beginning

Before you begin performing preventive maintenance on the LaserWriter II, be sure to do the following:

- Power off and unplug the printer.
- Prepare your workstation for electrostatic discharge (ESD) prevention.
- Remove the paper cassette.
- Remove the toner cartridge.

Safety

1. **Always** unplug the printer before taking it apart.
2. **Never** disconnect the optical fiber from the DC controller PCA or remove it from the laser/scanner assembly when the printer is turned on. The fiber carries infrared laser radiation, which you cannot see but which can permanently damage your eyes or someone else's. Even if you don't look directly at the fiber, the light can enter the eye by bouncing off reflective surfaces.
3. Whenever the printer is plugged in and the covers are removed, be careful where you put your hands. There are dangerous voltages in and around the Power Supply Block, DC Power Supply, and High Voltage Power Supply.
4. Warning labels appear in locations on the printer wherever special attention is needed. **Obey the instructions on the labels.**

Electrostatic Discharge Precautions

Be sure to follow the ESD prevention information located in Section 1, Basics, to avoid damage to any LaserWriter II electronics.

Setup

Before performing any LaserWriter II maintenance, set up the LaserWriter II and your work area as follows.

Materials Required

4' x 4' dropcloth
Electrostatic discharge prevention kit

Procedure

1. Prepare the LaserWriter II for service by removing the toner cartridge and paper cassette, disconnecting all cables, and unplugging the power cord.
2. Set the LaserWriter II on or next to your grounded workpad.
3. Put on your wriststrap and connect it to your grounded workpad. (While performing these procedures, place any removed electronic parts on the workpad.)
4. To protect the floor from grease and spilled toner, spread a drop cloth under your work area. Always hold the toner cartridge over the drop cloth to catch any toner that might spill. Place all tools and removed **nonelectronic** parts on the drop cloth to keep them and the area clean.

Repair Log Label

The Repair Log Label (Figure 1, #1) will help you perform preventive maintenance on the LaserWriter II printer. The label provides spaces for the following information:

- **Date**
The date of the repair or preventive maintenance
- **Repair Action**
The nature of the repair or type of preventive maintenance
- **Approximate Page Count**
The number of pages printed

Each Apple controller-I/O board comes with a label. You can also order the label separately from your regional Apple Support Center. Affix a label to the bottom panel of every LaserWriter II and LaserWriter/LaserWriter Plus.

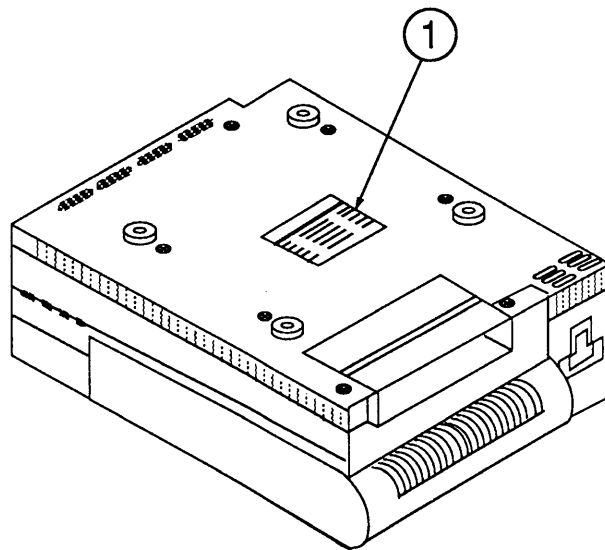

FIGURE 1

□ MAINTENANCE SCHEDULE

Schedule

Based on the length of time the printer has been in use, inspect, clean, and (if necessary) replace the items below.

- **End-User Maintenance**

The customer should clean the following items on an as-needed basis:

- Case
- Primary corona wire
- Transfer corona wire
- Transfer guide
- Discharging pins
- Fuser rollers

- **Dealer Service—Standard Maintenance**

The dealer should clean the following items every 12 months or during service:

- Items listed in "End-User Maintenance"
- Separation claws
- Paper guide
- Lower delivery guide
- Transfer corona assembly
- Registration rollers

The dealer should also replace the ozone filter and check the fan every 50,000 copies.

- **Dealer Service—100,000-Copy Refurbishment**

The dealer should replace the following items every 100,000 copies. (Refer to Checking the Print Count in this section to determine the number of copies printed.)

- Fuser Assembly
- Pick-up Rollers
- Transfer Guide Assembly
- Preconditioning Exposure Assembly
- Transfer Corona Assembly

Checking the Print Count

The LaserWriter II NT, NTX, f, and g printers keep track of the number of copies that have been printed using the installed controller and display this number (Figure 2, #1) at the bottom of each startup test page. **If the controller-I/O board has never been repaired or upgraded, that number will be accurate.**

If the controller-I/O board has been replaced or upgraded, or the print count is suspect, you will need to approximate the print count. Use the information on the Repair Log Label and consult with the customer to determine the number of copies printed.

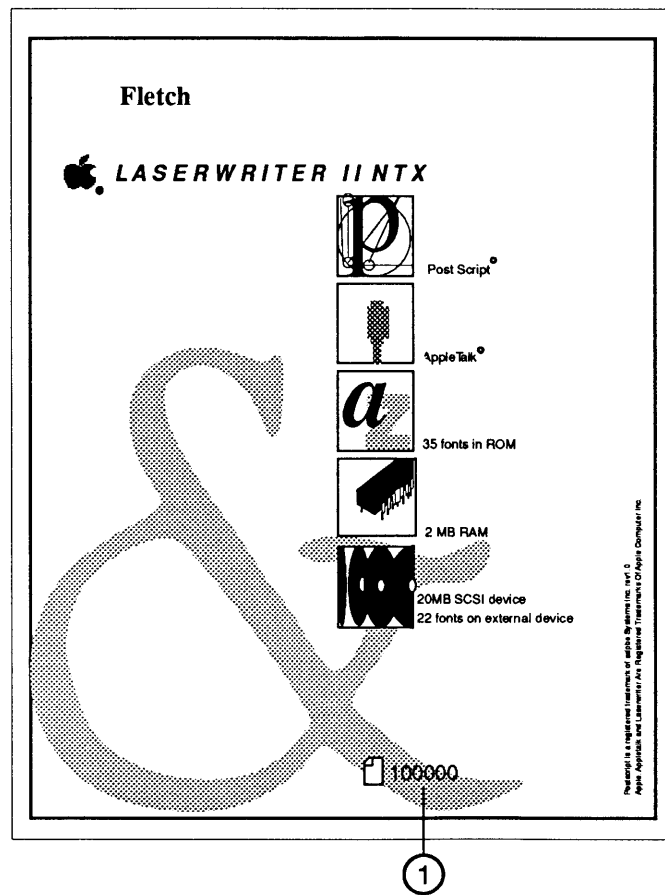

FIGURE 2

LaserWriter II SC

If an SC controller-I/O board is being used, the print count must be estimated by consulting with the customer and by using the Repair Log Label.

□ END-USER MAINTENANCE

Materials Required

Cleaning brush (located within the printer)
Cotton-tipped swabs
Soft, lint-free cloth (for cleaning)
New fuser roller cleaner pad

Cleaning Procedures

The following procedures should be performed on an as-needed basis by the customer. They should also be performed anytime the printer is being serviced.

Case

Clean the exterior of the printer with a clean, soft, damp cloth. Use a mild soap or detergent, if necessary.

CAUTION: *Never use an ammonia-based cleaner on the LaserWriter II. These cleaners can discolor the plastic.*

Primary Corona Wire

Clean the primary corona wire by inserting the cleaning brush (Figure 3, #1) into the long slot (Figure 3, #2) of the toner cartridge (between the two light-blocking shutters) and move it back and forth in the slot.

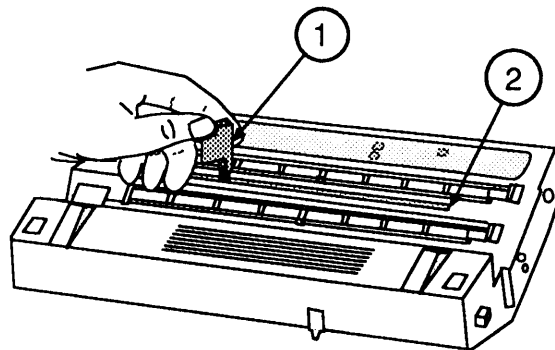

FIGURE 3

Transfer Corona Wire

Gently draw the cotton swab (provided with a new toner cartridge) up and down the corona wire (Figure 4, #1).

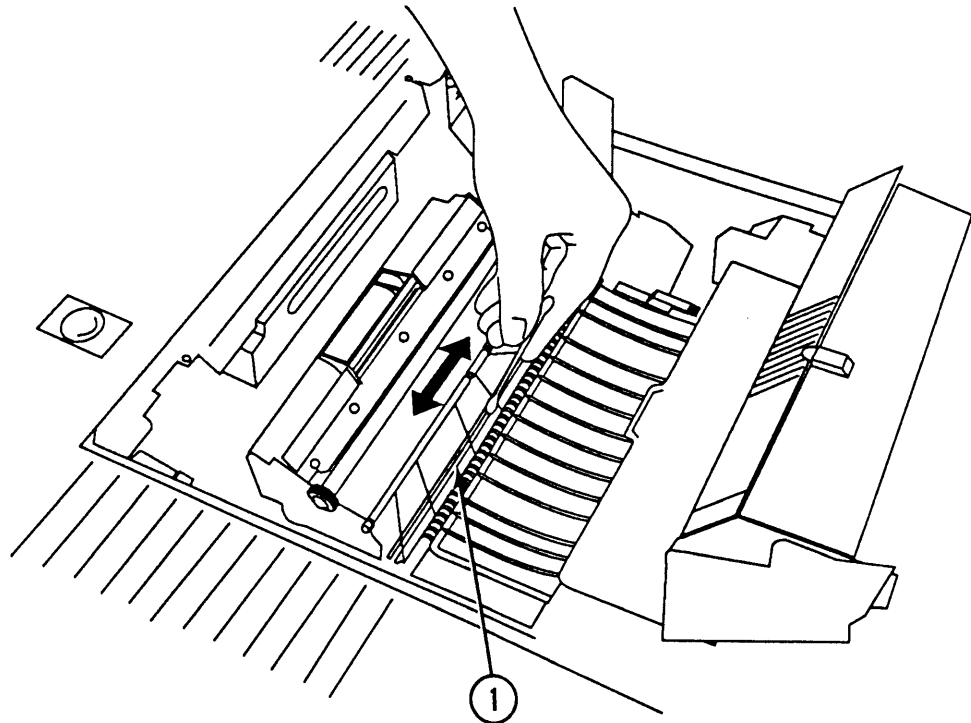

FIGURE 4

Transfer Guide Assembly

Clean the transfer guide assembly (Figure 5, #1) with a clean, soft, **slightly** damp cloth.

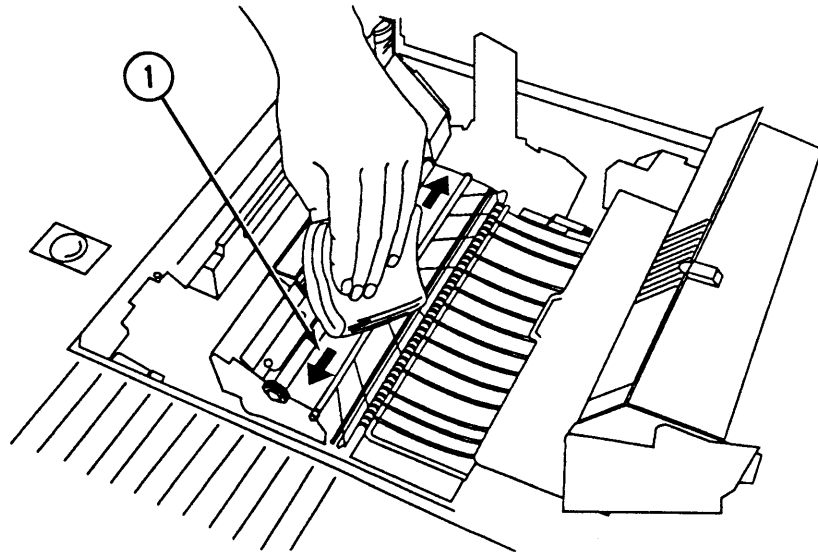

FIGURE 5

Discharging Pins

Use the cleaning brush to remove any dirt, dust, or toner from the discharging pins (Figure 6, #1).

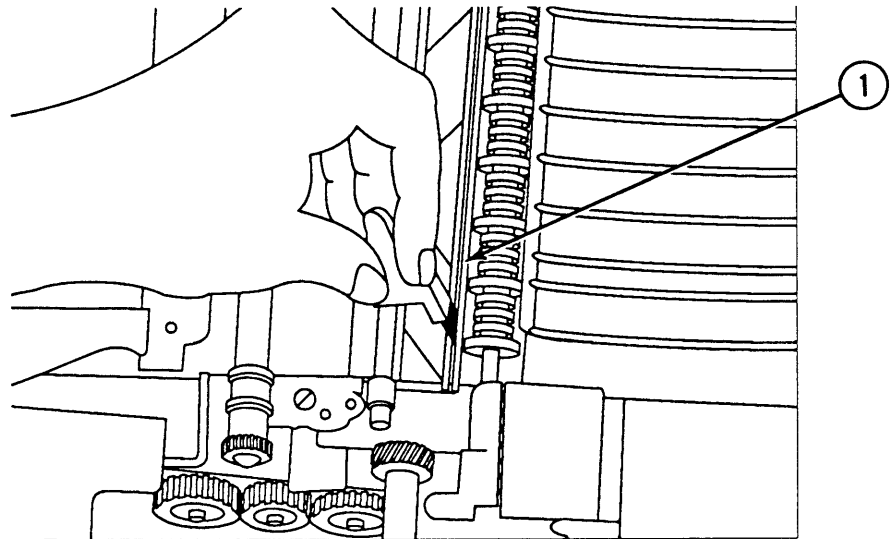

FIGURE 6

Fuser Rollers

Use the pad at the end of a new fuser roller cleaning pad to clean the fuser rollers. Clean the rollers by drawing the cleaning pad up and down the roller.

CAUTION: Before servicing the fuser rollers, make sure that the LaserWriter II has been off at least five minutes to allow the fuser assembly to cool.

□ STANDARD MAINTENANCE

Materials Required

4' x 4' dropcloth
2 Soft, lint-free cloths (for cleaning)
Cotton-tipped swabs
Small, medium-hardness bristle brush (for cleaning the separation claws)
Alcohol (ethyl or isopropyl; pure or denatured)

Cleaning Procedures

The following procedures should be performed every 12 months or when the printer is being serviced.

Separation Claws

The separation claws (Figure 7, #1) skim the paper from the fuser rollers after the toner has been fused onto the paper. It is important that the claw tips remain smooth and sharp to prevent paper jams.

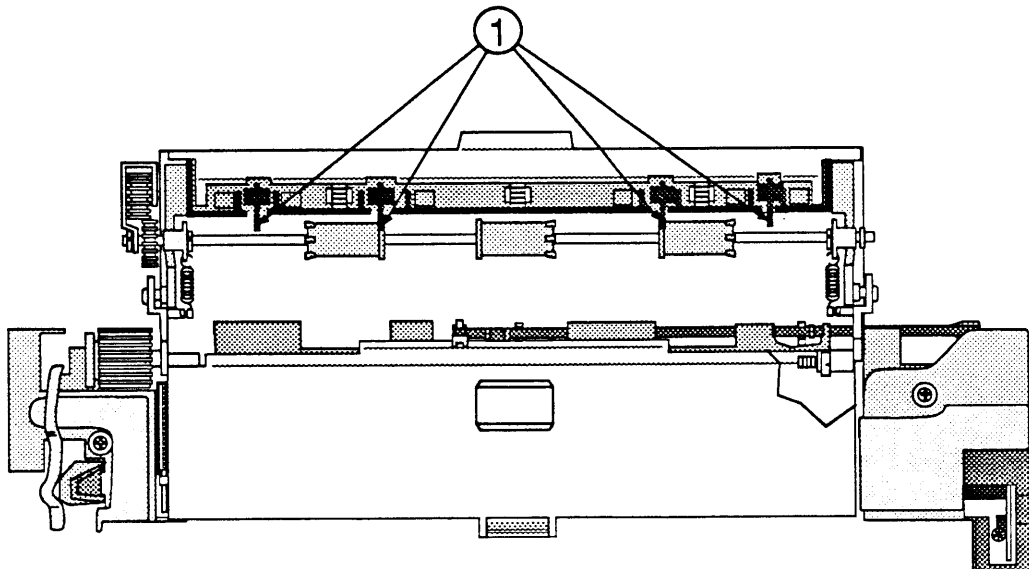

FIGURE 7

1. Clean the separation claws with a brush, being careful not to damage the leading edge.
2. Wipe the separation claws clean with a cloth dampened with alcohol.

Paper Guides

The upper and lower paper guides (Figure 8, #1) aid in the movement of the paper from the feeder guide into the fuser rollers. Over time the paper guides can collect dirt and toner from the paper and cause stains and paper jams.

Clean the paper guides with the cloth dampened with alcohol.

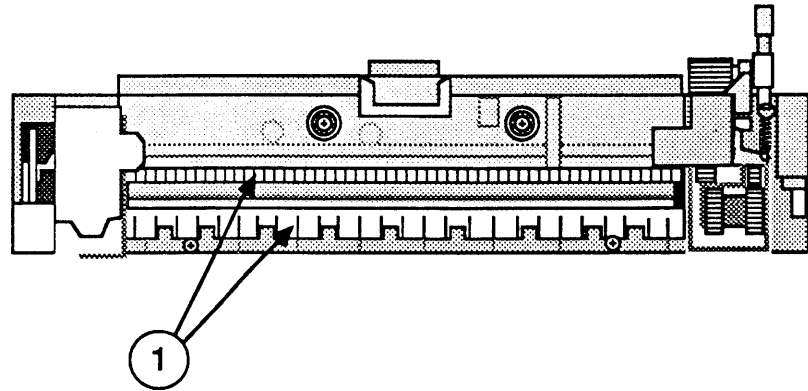

FIGURE 8

Lower Delivery Guide

The lower delivery guide (Figure 9, #1) assists the paper as it exits the fuser rollers. Over time it can collect dirt and toner from the paper and cause stains on the paper and paper jams.

Clean the lower delivery guide with the cloth dampened with alcohol.

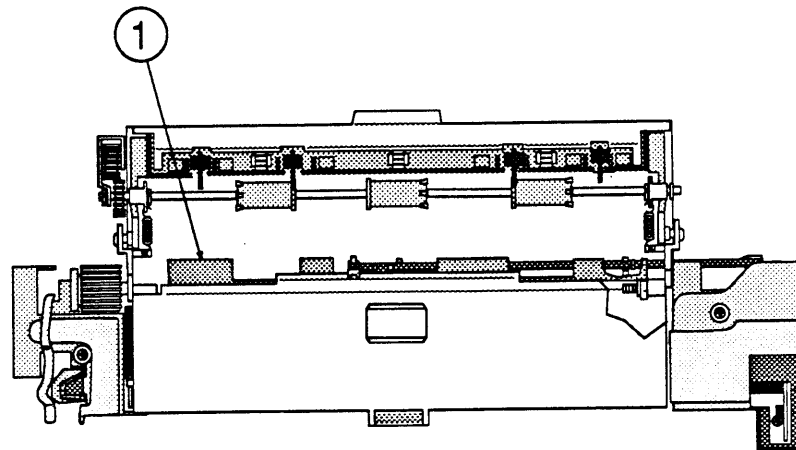

FIGURE 9

Transfer Corona Assembly

Clean the transfer corona assembly by using a small vacuum cleaner; take care not to damage the transfer corona wire.

If the vacuum cleaner does not clean the assembly thoroughly, proceed as follows:

1. Remove the transfer corona assembly.
2. Shake the excess toner from the assembly into a wastebasket.
3. Use cotton swabs moistened with alcohol to clean the inside of the assembly, being careful not to damage the corona wire.
4. Replace the transfer corona assembly.

Registration Rollers

The registration rollers (Figure 10, #1) align the leading edge of the paper with the leading edge of the image on the photosensitive drum. The rollers over time can become contaminated and cause faulty print registration.

Clean the registration rollers with the cloth dampened with water.

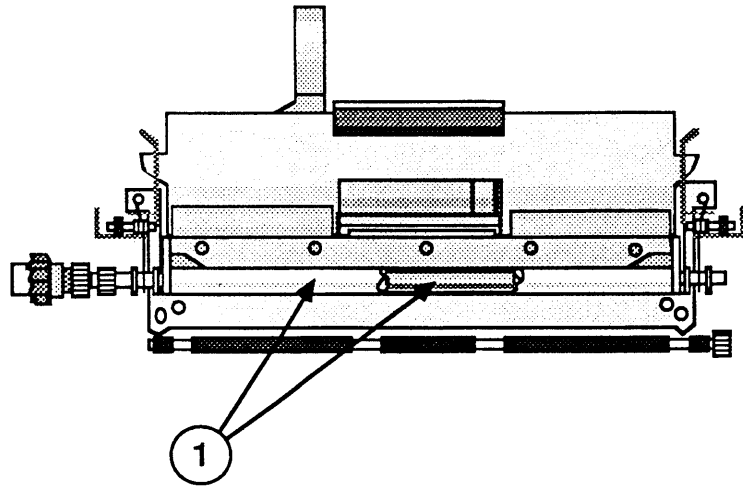

FIGURE 10

Feeder Guide

The feeder guide (Figure 11, #1) assists the paper as it moves beneath the toner cartridge. The guide can become dirty over time and cause stains on the paper.

Clean the feeder guide with the cloth dampened with water.

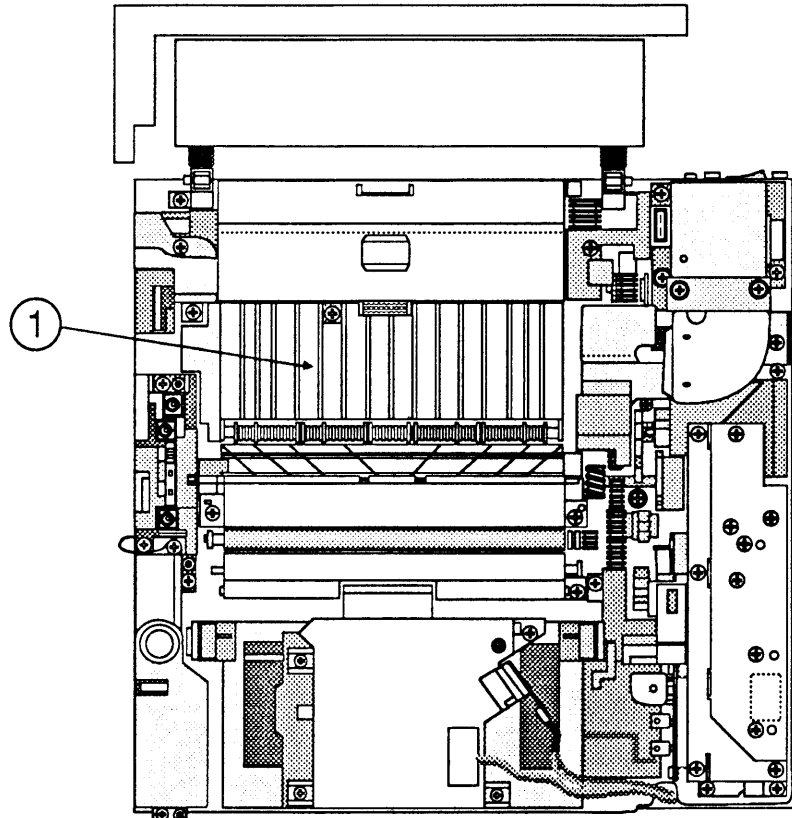

FIGURE 11

Replacing the Ozone Filter

Procedures for removing and replacing the ozone filter can be found in Section 2, Take-Apart.

Update the Repair Log

Record the date and type of preventive maintenance performed on the Repair Log Label on the bottom panel. **If a Repair Log Label is not affixed**, place one there at this time.

□ 100,000-COPY MAINTENANCE

Due to wear, certain modules within the LaserWriter II require cleaning or replacement after printing 100,000 copies. Follow the instructions that follow to inspect, clean, or replace these items.

Materials Required

LaserWriter II refurbishment kit
Small, medium-hardness bristle brush (for cleaning the upper and lower fans)
Cleaning brush (located within the printer)
Soft, lint-free cloth

The list of modules included in the refurbishment kit can be found under "Maintenance Schedule, Dealer Service—100,000-copy refurbishment."

Procedure

1. Remove the cover set.
2. Remove the DC power supply.
3. Remove the paper feed assembly.
4. Exchange the paper feed roller(s).
5. Replace the paper feed assembly.
6. Remove the transfer guide.
7. Remove the high voltage power supply.
8. Exchange the transfer corona assembly.
9. Replace the high voltage power supply.
10. Exchange the transfer guide assembly.
11. Replace the DC power supply.
12. Exchange the fuser assembly.
13. Check the Repair Log Label and see if one year has passed since the ozone filter was replaced. **If so,** replace the ozone filter.

14. Clean the upper and lower fans as follows:
 - a) Remove the upper fan.
 - b) Use the brush to clean the fan blades.
 - c) After brushing, remove the loose toner by vacuuming.
 - d) Replace the upper fan.
 - e) Repeat steps a) through d) for the lower fan.
15. Replace the cover set.
16. Exchange the preconditioning exposure assembly.
17. Clean the discharging pins using the cleaning brush to remove any dirt, dust, or toner (Figure 12, #1).

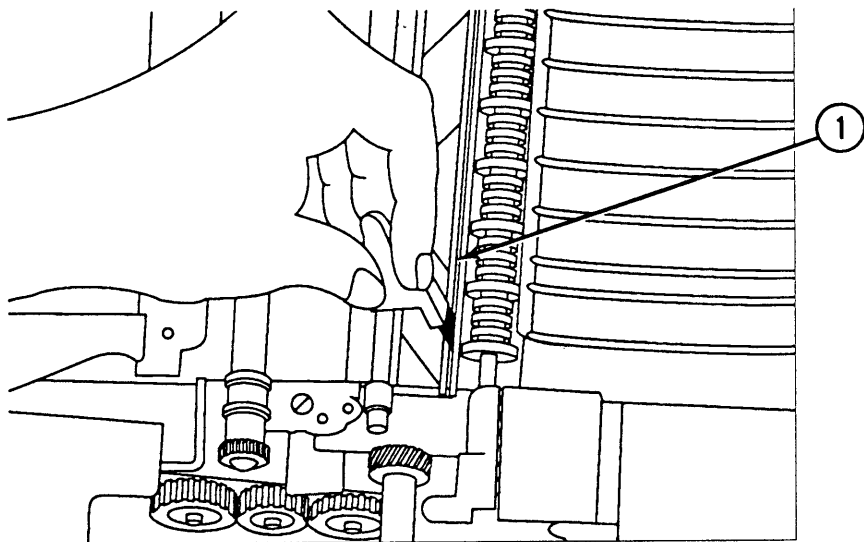

FIGURE 12

18. Clean the exterior of the printer with a clean, soft, damp cloth. Use a mild soap or detergent, if necessary.

CAUTION: *Never use an ammonia-based cleaner on the LaserWriter II. These cleaners can discolor the plastic.*

19. **If a new toner cartridge is not being installed at this time**, clean the primary corona wire by inserting the cleaner brush (Figure 13, #1) into the long slot (Figure 13, #2) of the toner cartridge (between the two light-blocking shutters) and moving it back and forth in the slot.

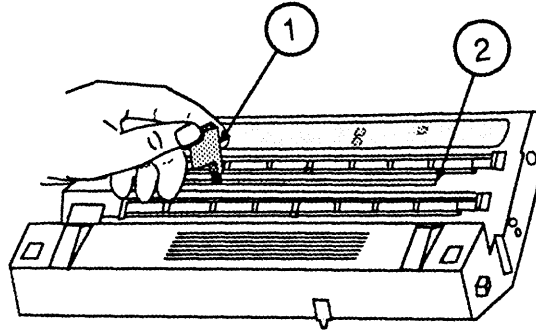

FIGURE 13

20. Record the date and type of service performed on the Repair Log Label on the bottom panel. **If a Repair Log Label is not affixed**, place one there at this time.







LaserWriter II

Section 6 – Additional Procedures

□ CONTENTS

6.3	Controller-I/O Board Installation
6.3	Introduction
6.3	Print Engine Check
6.4	Configuring the Controller-I/O Board
6.5	Installing the Controller-I/O Board
6.6	Checking the Installation
6.9	Repackaging Checklist
6.9	NTX Memory Upgrade
6.9	SIMM Identification
6.10	RAM Configurations
6.11	RAM Upgrades
6.13	IIf and IIG Memory Upgrade
6.13	SIMM Identification
6.14	RAM Configurations
6.15	RAM Upgrades
6.17	NTX ROM Upgrade
6.17	Introduction
6.17	Installing the ROM Upgrade
6.18	Checking the ROM Upgrade
6.20	220 V Repair and Conversion
6.20	110 V to 220 V Conversion
6.20	220 V to 110 V Conversion

Note: Instructions for underlined steps are in Section 2, Take-Apart.



□ CONTROLLER-I/O BOARD INSTALLATION

Introduction

Apple ships the LaserWriter II without the controller-I/O board installed. Prior to delivering the printer to the customer, test the print engine, configure and install the controller-I/O board, and verify the installation by printing from a Macintosh computer.

Print Engine Check

Before installing the controller-I/O board in the printer, verify that the print engine is operating properly.

Materials Required

LaserWriter II printer
Paper cassette
Paper
Power cord
Toner cartridge
Pencil

Procedure

1. Unpack the LaserWriter II by following the procedures in the *Owner's Guide*.

CAUTION: *Be careful when removing the antistatic bag from the printer. The bag can catch on the shield plate at the left side of the printer and damage the bracket.*

2. Depress the release button and open the top cover.
3. Install the toner cartridge.
4. Fill the paper cassette with paper and install the cassette in the printer.
5. Plug in the printer and switch on the power.

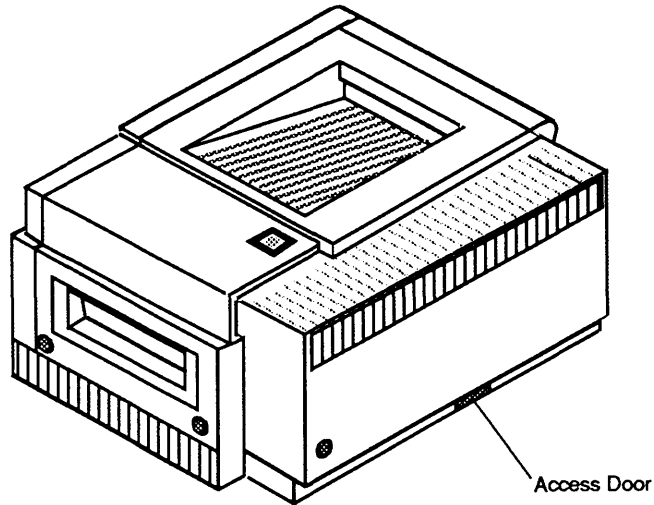

Figure 6-1 Printer Access Door

6. Open the access door (**Figure 6-1**) on the lower portion of the rear of the printer.
7. Insert the pencil into the opening and depress the engine self-test switch.
8. **If an engine self-test page appears**, proceed to "Configuring the Controller-I/O Board." **If an engine self-test page does not appear**, refer to Section 4, Troubleshooting.
9. Replace the access door.

Configuring the Controller-I/O Board

You should not need to reconfigure the controller-I/O boards, which ship as follows:

- The SC board ships with the SCSI priority set to 4.
- The NT/NTX boards are configured at the factory to communicate via AppleTalk. If you wish to communicate via the 25-pin serial port, refer to the *Owner's Guide* for the proper switch settings.
- The IIf and IIg boards provide a port arbitration feature that supports concurrent communication via all ports.

Installing the Controller-I/O Board

The controller-I/O board is extremely sensitive to electrostatic discharge (ESD). Be sure to read the information on electrostatic discharge prevention in Section 1, Basics, before you remove the controller-I/O board from its antistatic bag.

Materials Required

Properly configured controller-I/O board
(for the SC, NT, NTX, IIf, or IIg)
#2 Phillips screwdriver
ESD-safe workstation

Procedure

1. Make sure the printer is switched OFF.

CAUTION: Never change controller-I/O boards when the printer is on. You can cause permanent damage to both the LaserWriter II and the controller-I/O board.

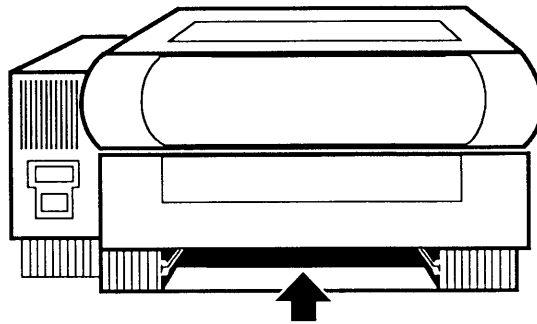

Figure 6-2 Controller-I/O Board Compartment

2. Hold the controller-I/O board by the metal I/O panel at the back of the board and by the side of the board. Carefully slide the board into its compartment (**Figure 6-2**) at the bottom of the printer. The opening is on the opposite side of the printer from the paper cassette tray.
3. Carefully push the controller-I/O board into the opening as far as the board will go.
4. Tighten the two retaining screws on the controller-I/O board.

Checking the Installation

Before delivering the printer to the customer, perform the following checks to verify your installation.

Materials Required

LaserWriter II printer (with controller-I/O board installed)
Paper cassette
Paper
Power cord
Toner cartridge

For the SC:

Macintosh Plus, SE, or II
SCSI system cable
SCSI terminator
SC Printer Installation disk

For the NT/NTX, IIf, IIg:

Any Macintosh computer
LocalTalk connector box for the Macintosh
LocalTalk connector box with a Mini DIN-8 connector (for the printer)
LocalTalk cable
Appropriate *Printer Installation* disk

Note: To fully test the IIf and IIg, you will need a computer capable of running System 7.0. If connecting the IIg via the Ethernet port, you will also need two Apple Ethernet connector boxes and an Apple Ethernet cable.

SC

When installing the SC controller-I/O board, follow this procedure:

1. Plug in the printer and switch on the power.
2. Switch on the printer and wait for the startup test page. (The time it takes for the test page to print will depend on the amount of RAM in the printer.)

If no startup test page appears within three minutes, refer to Section 4, Troubleshooting.

3. Place the *SC Installation Disk* in the internal disk drive and switch on the Macintosh.
4. Double-click on the *SC Printer Installation* disk icon.

5. Select **Chooser** from the  menu.
6. Select the SC as the device type.
7. Close **Chooser**.
8. Select **Print Catalog** from the File menu.

If the LaserWriter prints a catalog, the installation is complete. Proceed to the Repackaging Checklist at the end of this procedure.

If the LaserWriter does not print a catalog, refer to Section 4, Troubleshooting.

NT, NTX, IIf, IIg

When installing the NT, NTX, IIf, or IIg controller-I/O boards, follow the procedure below:

1. Switch on the printer and wait for the startup test page. (The time it takes for the test page to print will depend on the amount of RAM in the printer.)

If no startup test page appears within three minutes, refer to Section 4, Troubleshooting.

If the printer produces a startup test page, proceed to step 2.

2. Switch off the printer.
3. Connect the printer via the LocalTalk or Ethernet port as follows:

LocalTalk:

- Connect a LocalTalk connector box to the 8-pin Mini-DIN connector on the controller-I/O board.
- Connect a LocalTalk connector box to the printer port at the rear of the Macintosh.
- Connect a LocalTalk cable between the printer and Macintosh LocalTalk connector boxes.

Ethernet (IIg only):

- Connect the short cable that extends from one Apple Ethernet connector box to the Ethernet port on the IIg controller-I/O board.
 - Connect the short cable that extends from another Apple Ethernet connector box to the Ethernet port on the computer.
 - Connect the two Ethernet connector boxes with an Apple Ethernet cable.
4. Switch on the printer and wait for the startup test page.
 5. Place the *Printer Installation* disk in the internal disk drive and switch on the Macintosh.
 6. Double-click on the *Printer Installation* disk icon.
 7. Select **Chooser** from the  menu.
 8. Select the LaserWriter as the device type. When the LaserWriter name appears, select it.
 9. Close **Chooser**.
 10. Select **Print Catalog** from the File menu.

If the LaserWriter prints a catalog, the installation is complete. Proceed to the Repackaging Checklist at the end of this procedure.

If the LaserWriter does not print a catalog, refer to Section 4, Troubleshooting.

Repackaging Checklist

When you have finished testing your installation and before you transport the printer to its final destination, complete the following checklist:

- Remove the toner cartridge from the printer.
- If you have opened the Accessory Kit, make sure to repack the following items:
 - AC power cord
 - Disks
 - Manual
- Place the LaserWriter II in its antistatic bag, and repack it in the box with all the original shipping materials, including the antistatic bag for the controller-I/O board.

NTX MEMORY UPGRADE

RAM for the NTX controller-I/O board comes in packages known as SIMMs (single in-line memory modules). Each SIMM contains eight surface-mounted DRAM (dynamic RAM) chips on a small, narrow printed circuit board. Each SIMM board has contacts on one edge that fit into sockets on the NTX board.

The NTX controller-I/O board ships from Apple with 2 MB of RAM. You may increase the RAM by installing additional SIMMs.

SIMM Identification

The SIMMs are available in two sizes: 256K and 1 MB.

CAUTION: The SIMMs on the NTX controller-I/O board are different from those used in the Macintosh Plus, SE, and II. DO NOT use Macintosh Plus, SE, or II SIMMs on the NTX board.

256K SIMMs

The 256K SIMMs have eight ICs (integrated circuits). Each IC has five pins on each side.

CAUTION: You must use 120 ns 256K SIMMs on the NTX controller-I/O board. The 150 ns SIMMs will cause serious timing problems.

1 MB SIMMs

Like the 256K SIMMs, the 1 MB SIMMs have eight ICs; each IC on the 1 MB SIMMs, however, has a total of twenty pins. The ICs on the 1 MB SIMMs are also approximately 25 percent larger than those on the 256K SIMMs.

CAUTION: You must use 120 ns 1 MB SIMMs on the NTX controller-I/O board. The 150 ns SIMMs will cause serious timing problems.

RAM Configurations

Various RAM configurations are possible on the NTX controller-I/O board, depending upon the number and size of the SIMM modules you install. The following table summarizes the various configurations possible on the NTX board.

RAM	Bank 0	Bank 1	Bank 2
2 MB	Four 256K SIMMs	Four 256K SIMMs	None
3 MB	Four 256K SIMMs	Four 256K SIMMs	Four 256K SIMMs
4 MB	Four 1 MB SIMMs	None	None
5 MB	Four 1 MB SIMMs	Four 256K SIMMs	None
8 MB	Four 1 MB SIMMs	Four 1 MB SIMMs	None
9 MB	Four 1 MB SIMMs	Four 1 MB SIMMs	Four 256K SIMMs
12 MB	Four 1 MB SIMMs	Four 1 MB SIMMs	Four 1 MB SIMMs

Table 6-1 NTX RAM Configurations

RAM Upgrades

To upgrade the NTX controller-I/O board, use Table 6-1 to determine the number and size of SIMM modules to install. Note that the NTX does not support the 6 MB memory configuration.

The NTX board has three banks of SIMM sockets, which are labeled Bank 0, Bank 1, and Bank 2 (**Figure 6-3**). Each bank contains four slots. Fill all four slots of each bank with like-sized SIMMs, or leave all four slots of a bank empty. Fill Bank 0 first, then Banks 1 and 2.

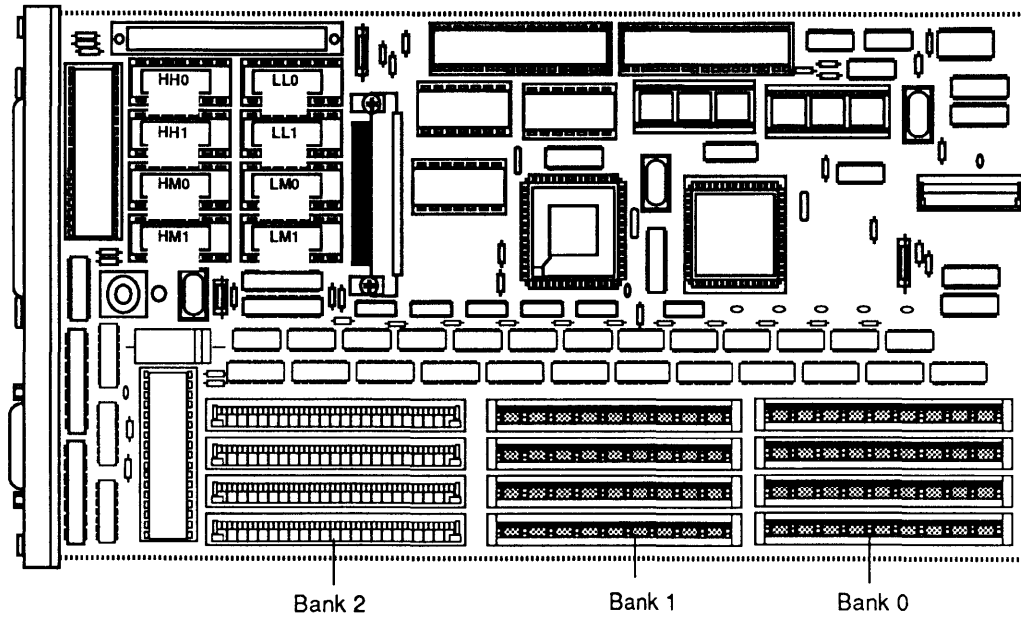

Figure 6-3 SIMM Banks on the NTX Board

Materials Required

Grounded workbench pad and wriststrap
SIMM modules to be installed

CAUTION: SIMMs are very susceptible to damage from ESD and skin acid. Handle only by the corners!

Remove

To remove a SIMM:

1. Remove the NTX controller-I/O board.
2. Place the NTX board on a grounded workbench pad and put on your grounding wriststrap.

3. Removing a SIMM involves releasing the metal tabs on the ends of the socket (**Figure 6-4**). Refer to the *You Oughta Know* tab for instructions on using the SIMM removal tool.

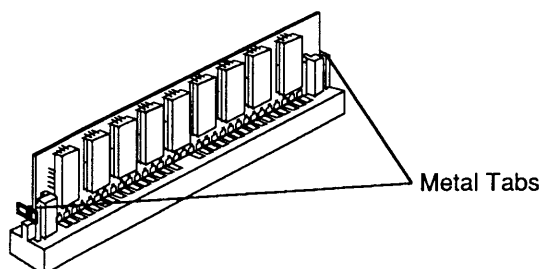

Figure 6-4 Metal Tabs on SIMM Socket

Replace

To replace or install a SIMM:

1. With the contacts on the SIMM pointing down (**Figure 6-5**), set the SIMM into the connector at an angle. Push back on the top corners of the SIMM. You will hear a click when the SIMM snaps into place.

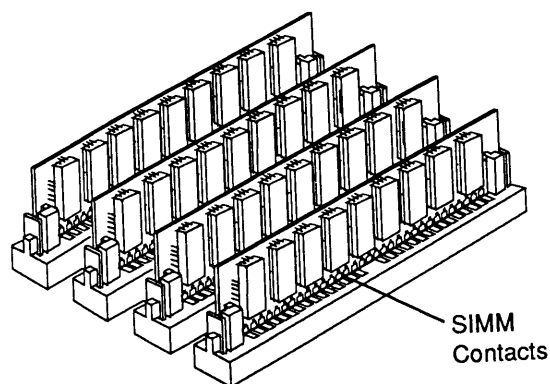

Figure 6-5 Installing SIMMs

2. Replace the NTX controller-I/O board.

□ IIf and IIg MEMORY UPGRADE

RAM for the IIf and IIg controller-I/O boards comes in SIMM packages. Each SIMM contains either two or eight surface-mounted DRAM chips on a small, narrow printed circuit board. Each SIMM board has contacts on one edge that fit into sockets on the IIf or IIg board.

Apple ships the IIf controller-I/O board with 4 MB of RAM and the IIg controller-I/O board with 8 MB of RAM. The LaserWriter IIf and IIg use the same RAM as the Macintosh IIsi and IIfci computers. You may increase the RAM by installing additional SIMMs.

SIMM Identification

Apple-manufactured SIMMs for the IIf and IIg come in two sizes: 256K and 1 MB.

CAUTION: *The SIMMs used on the IIf and IIg controller-I/O boards are different from those used in the LaserWriter SC or NTX printers. DO NOT attempt to use LaserWriter SC or NTX SIMMs on the IIf or IIg boards.*

IMPORTANT: *Refer to the  Quick Reference: SIMM Compatibility chart for a comprehensive list of all compatible SIMMs.*

256K SIMMs

The 256K SIMMs have two ICs.

CAUTION: *You must use 80 ns 256K SIMMs on the IIf and IIg controller-I/O boards. The 120 ns and 150 ns SIMMs will cause serious timing problems.*

1 MB SIMMs

The 1 MB SIMMs have either two or eight ICs.

CAUTION: *You must use 80 ns 1 MB SIMMs on the IIf and IIg controller-I/O boards. The 120 ns and 150 ns SIMMs will not function properly.*

RAM Configurations

Various RAM configurations are possible on the IIf and IIg controller-I/O boards, depending upon the number and size of the SIMM modules you install. The following table summarizes the various configurations possible on the IIf and IIg boards.

RAM	Bank 0	Bank 1
2 MB*	Four 256 K SIMMs	Four 256 K SIMMs
4 MB*	Four 1 MB SIMMs	None
5 MB	Four 1 MB SIMMs	Four 256 K SIMMs
8 MB	Four 1 MB SIMMs	Four 1 MB SIMMs
16 MB	Four 4 MB SIMMs	None
17 MB	Four 4 MB SIMMs	Four 256 K Simms
20 MB	Four 4 MB SIMMs	Four 1 MB SIMMs
32 MB	Four 4 MB SIMMs	Four 4 MB SIMMs

*LaserWriter IIf only.

Table 6-2 IIf and IIg RAM Configurations

RAM Upgrades

To upgrade the Iif or Iig controller-I/O board, use Table 6-2 to determine the number and size of SIMM modules to install. The Iif and Iig boards each have two banks of SIMM sockets, which are labeled Bank 0 and Bank 1 (**Figure 6-6**). Each bank contains four slots. Fill all four slots of a bank with like-sized SIMMs, or leave all four slots of the bank empty. Fill Bank 0 first, then Banks 1 and 2.

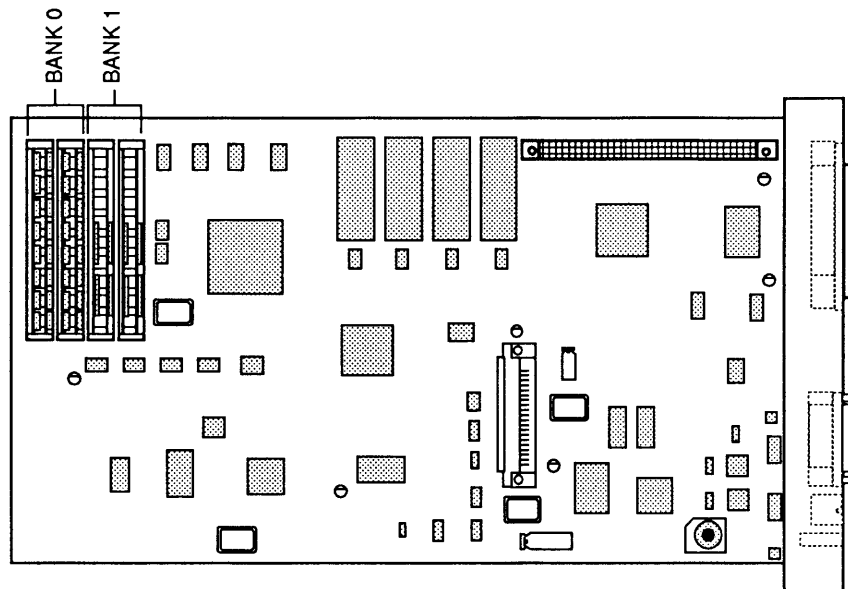

Figure 6-6 Location of RAM on Iif and Iig Boards

Materials Required

Grounded workbench pad and wriststrap
SIMM modules to be installed

CAUTION: SIMMs are very susceptible to damage from ESD and skin acid. Handle only by the corners!

Remove

To remove a SIMM:

1. Remove the Iif or Iig controller-I/O board.
2. Place the Iif or Iig board on a grounded workbench pad and put on your grounding wriststrap.

3. Removing a SIMM involves releasing the metal tabs on the ends of the socket (**Figure 6-7**). Refer to the *You Oughta Know* tab for instructions on using the SIMM removal tool.

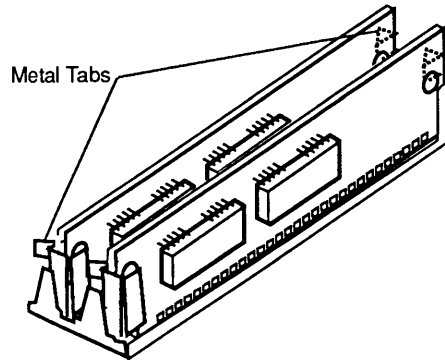

Figure 6-7 Removing a SIMM

Replace

To replace or install a SIMM:

1. With the SIMM contacts pointing down (**Figure 6-8**), place the SIMM into the connector at an angle. Push down on the top corners of the SIMM. You will hear a click when the SIMM snaps into place.

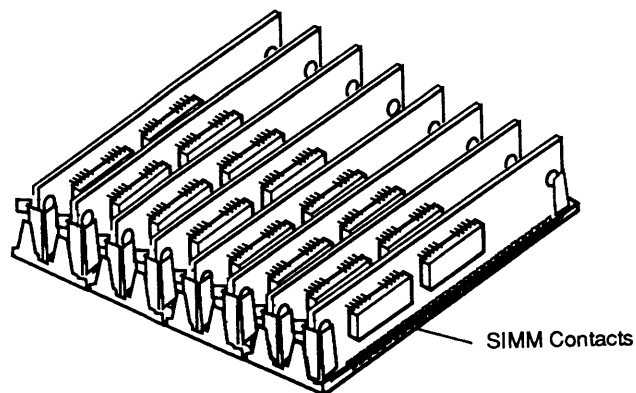

Figure 6-8 Replacing a SIMM

2. Replace the Iif or Iig controller-I/O board.

□ NTX ROM UPGRADE

Introduction

The LaserWriter II NTX ROM Upgrade provides the following enhancements for the LaserWriter II NTX printer:

- Software switching between PostScript and other emulation modes (D630 and HPLJ) on LocalTalk ports
- Support of multiple SCSI disks and SCSI disks larger than 40 MB
- Additional characters with HPLJ emulation mode

Materials Required

NTX controller-I/O board
NTX ROM Upgrade Kit
IC Extractor

Installing the ROM Upgrade

1. **Read the ESD precautions in the Basics section before you proceed!**
2. Switch off and unplug the printer.
3. Remove the controller-I/O board and place it on the grounded workbench pad.
4. Locate the eight ROM chips at locations **HH0, HH1, HM0, HM1, LL0, LL1, LM0, and LM1** on the controller-I/O board (**Figure 6-9**). Using an IC extractor, carefully remove the eight ROM chips from the board.
5. Remove the new ROM chips from their antistatic packaging. Handle the chips by their bodies, not their leads.
6. Look at the characters printed on each ROM chip. At the end of the first line of print you will find one of the following markings:

HH0, HH1, HM0, HM1, LL0, LL1, LM0, or LM1

These markings match the ROM socket locations on the controller-I/O board (**Figure 6-9**).

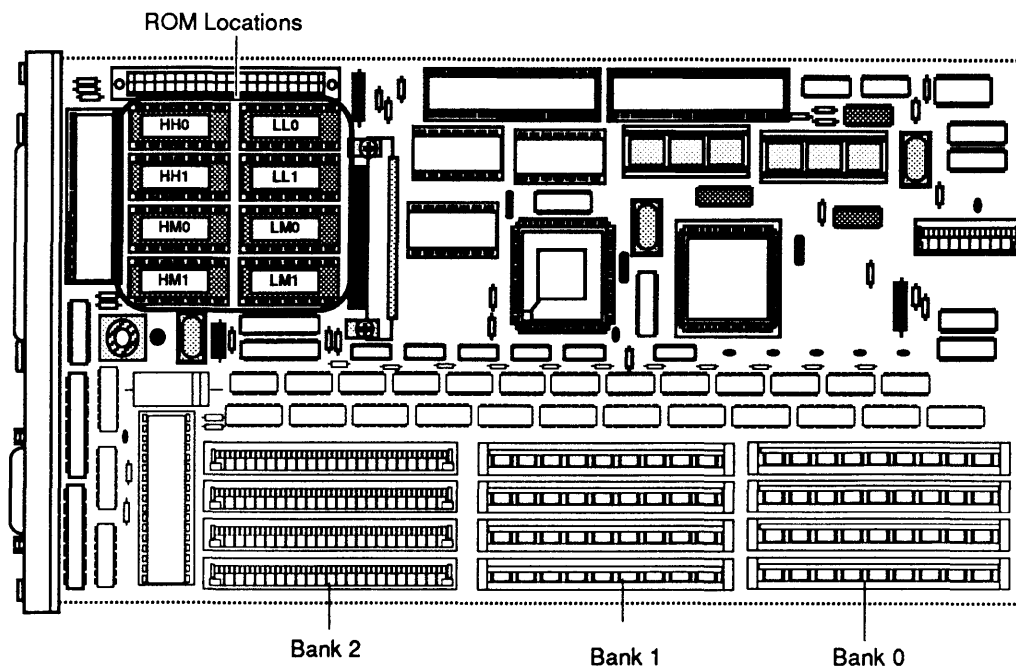

Figure 6-9 ROM Socket Locations

7. To install the new ROM, match the markings on each ROM chip with the corresponding socket on the controller-I/O board (**Figure 6-9**).

Note: The notch on each ROM chip should match the outline on the controller-I/O board.

8. Replace the controller-I/O board.

Checking the ROM Upgrade

1. Plug in the AC power cord and switch on the printer. The printer should produce a startup test page within two to three minutes.
2. **If the startup test page does not appear**, run the *NT/NTX ROM and SIMM Test* to identify any failing ROM chips. Replace any ROM chip that the test identifies as bad. Refer to Section 7, Diagnostics, for further information on setting up and running the *NT/NTX ROM and SIMM Test*.

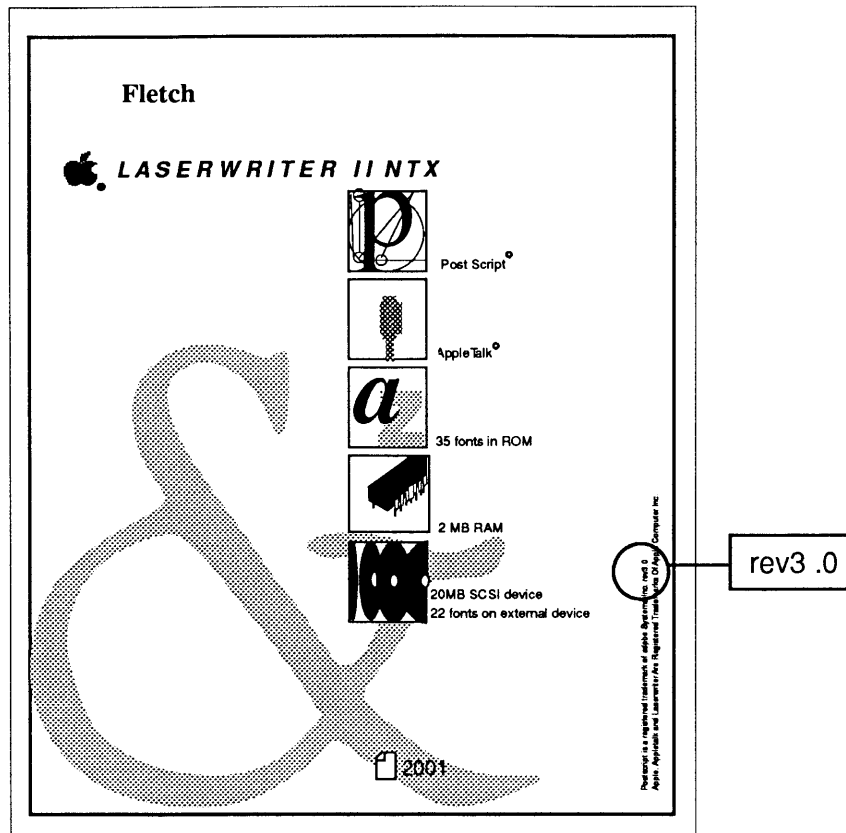

Figure 6-10 Verify ROM Version Number

3. **If the LaserWriter produces a startup test page,** locate the copy-right information on the bottom, right-hand side of the test page (**Figure 6-10**). At the end of the first line of print, you will find one of the following PostScript ROM version numbers:

- **Rev 1.0** - version number of the original PostScript ROMs
- **Rev 2.0** - version number of the Kanji PostScript ROMs installed on the LaserWriter II NTX-J
- **Rev 3.0** - version number of the enhanced PostScript ROMs

If the ROM upgrade procedure is successful, the startup test page will display the Rev 3.0 ROM version number.

□ 220 V REPAIR AND CONVERSION

LaserWriter II printers manufactured for the United States and Japan operate at line voltages of 110–115 volts; LaserWriter II printers manufactured for Europe and Australia operate at line voltages of 220–240 volts. To repair a 220–240 volt or 110–115 volt LaserWriter II, follow the procedures described in Section 2, Take-Apart.

To convert a 110–115 volt LaserWriter II to 220–240 volts, or a 220–240 volt LaserWriter II to 110–115 volts, follow the procedures below.

Materials Required

#2 Phillips screwdriver

110 V to 220 V Conversion

1. Depress the release button and open the top cover of the printer.
2. Remove the cover set.
3. Remove the 110 V fuser assembly and replace it with a 220 V fuser assembly.
4. Remove the 110 V power supply block and replace it with a 220 V power supply block.
5. Remove the 110 V DC power supply and replace it with a 220 V DC power supply.
6. Replace the cover set.

220 V to 110 V Conversion

1. Depress the release button and open the top cover of the printer.
2. Remove the cover set.
3. Remove the 220 V fuser assembly and replace it with a 110 V fuser assembly.

4. Remove the 220 V power supply block and replace it with a 110 V power supply block.
5. Remove the 220 V DC power supply and replace it with a 110 V DC power supply.
6. Replace the cover set.



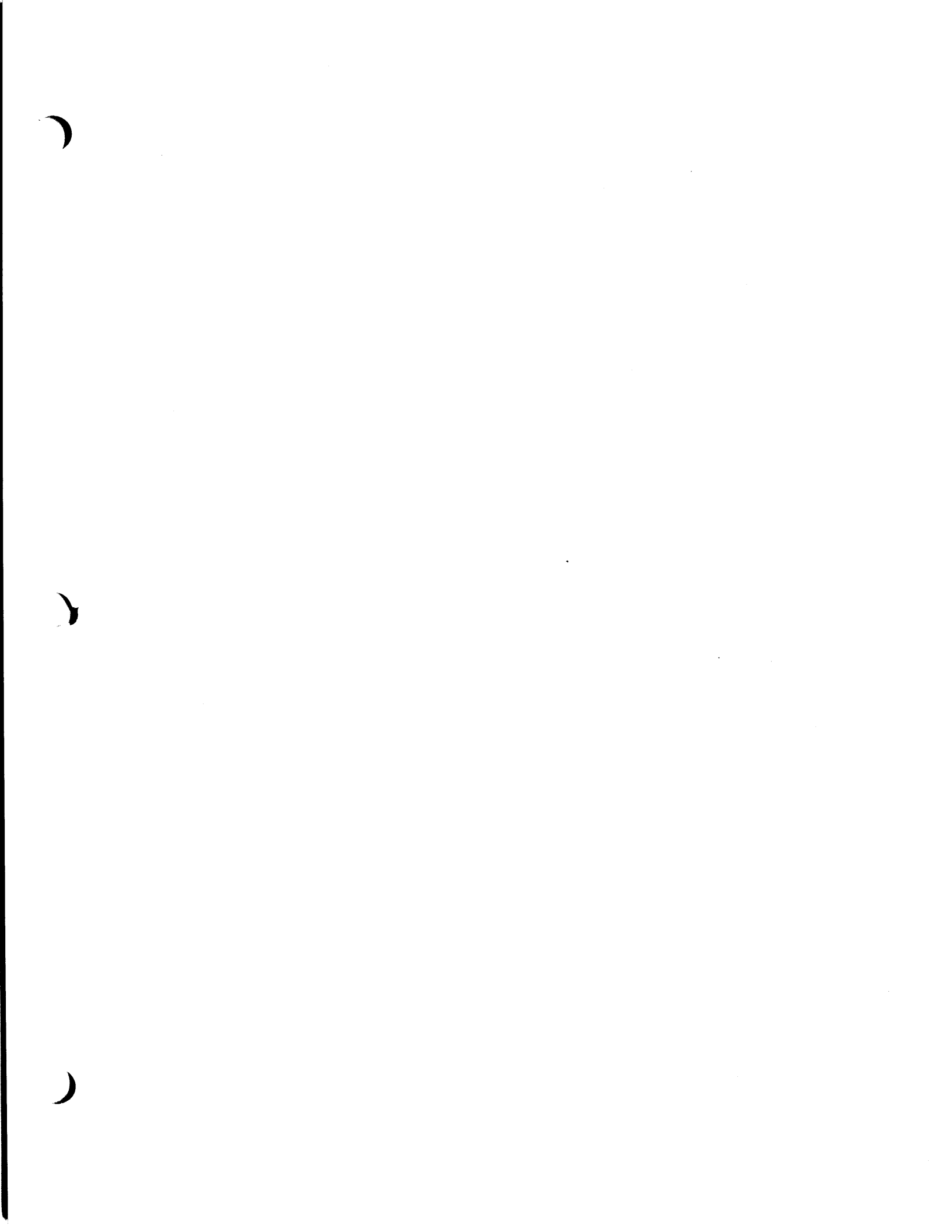



LaserWriter II

Section 7 – Diagnostics

□ CONTENTS

7.3	Introduction
7.3	LaserWriter II Test Connector
7.3	ESD Precautions
7.4	NT/NTX ROM and SIMM Test
7.4	Materials Required
7.4	Before You Start
7.4	Setting Up Test Station and UUT
7.5	Establishing Communication
7.6	Running the Test
7.7	ROM Identification
7.7	SIMM Identification



□ INTRODUCTION

The *NT/NTX ROM and SIMM Test* is a diagnostic tool that identifies defective ROM modules on the LaserWriter II NT I/O board, and defective ROM and SIMM modules on the LaserWriter II NTX I/O board. The *NT/NTX ROM and SIMM Test* runs on a Macintosh test station connected to the LaserWriter II communications port. The test performs the following functions:

- Communicates with and interprets the messages produced by the LaserWriter II's internal test manager
- Identifies defective ROM or SIMM modules
- Recommends a repair procedure

LaserWriter II Test Connector

To enable the Macintosh test station to communicate with the LaserWriter II test manager, the LaserWriter II Test Connector must be installed on the 25-pin serial port of the LaserWriter II I/O board. The test connector is covered with bright, yellow plastic to remind you to remove the connector when testing is completed. **If the test connector is not removed, the I/O board will remain in test manager mode and be unable to establish communication with the host computer(s) over an AppleTalk network.**

IMPORTANT: *Use of the test connector may alter the appearance of the Status LEDs.*

ESD Precautions

The LaserWriter II I/O board is the most expensive single module in the printer. It is therefore very important to protect the chips on the board from damage. To prevent ESD damage to the I/O board or any of its components, be sure to follow the ESD prevention information located in Section 1, Basics.

□ NT/NTX ROM AND SIMM TEST

Materials Required

LaserWriter II (unit under test or UUT)
Known-good Macintosh Plus, SE, SE/30, II, IIx, IIcx, or
IIfx (test station)
Macintosh Peripheral Test Volume 2 disk
APM/ImageWriter II to Apple IIGS /Macintosh Plus
cable (serial port cable)
LaserWriter II Test Connector
#2 Phillips screwdriver

Before You Start

The *NT/NTX ROM and SIMM Test* should be used only if the LaserWriter II print engine is operational. Before attempting to run the test, verify that the LaserWriter II print engine is functional by generating a service test print. (For information on how to produce a service test print, refer to "Test Prints" in Section 4, Troubleshooting.)

Setting Up Test Station and UUT

1. Connect the Macintosh test station to a wall socket with an AC power cord.
2. Place the LaserWriter II (UUT) next to the test station.
3. Connect the LaserWriter II (UUT) to a wall socket with an AC power cord.
4. Connect one end of the serial port cable (Figure 1, #1) to the LocalTalk port (Figure 1, #2) of the LaserWriter II (UUT).
5. Connect the other end of the serial port cable to the modem port (Figure 1, #3) of the Macintosh test station.
6. Install the yellow LaserWriter II Test Connector on the 25-pin serial port of the LaserWriter II (Figure 1, #4).

IMPORTANT: *The Macintosh may not be able to communicate with the LaserWriter II test manager unless the LaserWriter II Test Connector is installed.*

7. Connect a mouse (Figure 1, #5) (and keyboard, if desired) to the Macintosh test station.

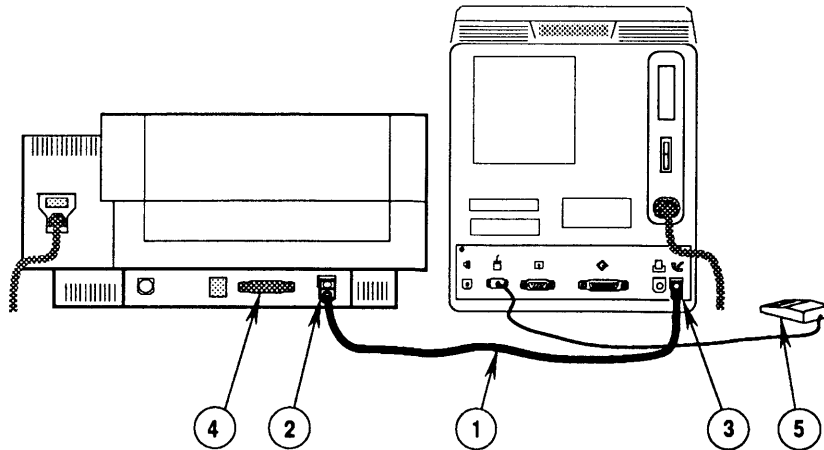

FIGURE 1

**Establishing
Communication**

1. Switch on the LaserWriter II (UUT).
2. Insert the *Macintosh Peripheral Test Volume 2* disk in the Macintosh test station, and switch on the Macintosh.
3. Open the disk icon and then the *NT/NTX ROM and SIMM Test* icon. The *NT/NTX ROM and SIMM Test* Start window (Figure 2) will appear on the test station screen.
4. To begin the test, click the Start button in the *NT/NTX ROM and SIMM Test* Start window.

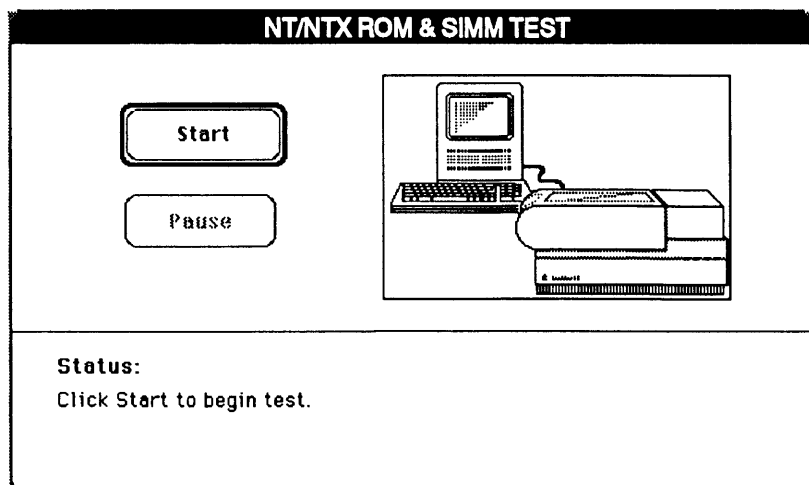

FIGURE 2

Running the Test

The *NT/NTX ROM and SIMM Test* will interact with you throughout the testing. When the test detects a failed ROM or SIMM module, the test stops, and a window indicates which module you should replace. While the test is running, please note the following:

- If the No Communication window is displayed, the I/O board may not detect the LaserWriter II Test Connector. Check the status LEDs on the side of the printer. If the green "ready" LED flashes briefly and then glows steady, all tests have passed and the I/O board is good.

Note: When the I/O board ROM tests are run, a signal is sent through the serial chip to the serial port. If the LaserWriter II Test Connector is installed, this signal is sent back to the ROM for detection. Detection of this signal by the ROM places the printer in test manager mode and allows communication with the diagnostic test. Some I/O boards have serial chip timing problems that prevent the correct timing of the signal sent from the ROM to the serial port and back. These I/O boards cannot detect the LaserWriter II Test Connector.

- If you have just replaced a ROM or SIMM module, and the test again identifies the same module as defective, the problem probably has a different cause. Reinstall the original module and replace the I/O board.
- If the Unknown Problem window is displayed, you may have answered one of the setup questions incorrectly. Check the I/O board type and the number of SIMM banks (if the board is an NTX), and run the test a second time before replacing the I/O board.
- Choose **Stop** to halt the testing and to return to the *NT/NTX ROM and SIMM Test* Start window. Choose **Start** when you wish to begin the test again.
- After selecting a response, click the Done button to continue.

IMPORTANT: *Do not select the Done button until you've completed every instruction given on the screen. Failure to complete the instructions may misdirect the test.*

- If all tests pass, the message **All tests passed** appears on the Status line at the bottom of the *NT/NTX ROM and SIMM Test Start* window.

IMPORTANT: *Do not forget to remove the LaserWriter II Test Connector from the back of the NT or NTX I/O board when you have completed testing. If the test connector is not removed, the I/O board will be unable to resume normal operation.*

ROM Identification

The NT and NTX I/O boards have eight ROMs installed. When replacing a failed ROM on the I/O board, verify that the new ROM has the same part number as the failed ROM. Only install ROMs with the same part numbers in the same ROM sockets. For additional information on ROM part numbers, refer to the Illustrated Parts section.

SIMM Identification

The SIMMs used on the NTX I/O board are available in two sizes, 256K and 1 MB.

256K SIMMs

The 256K SIMMs have eight ICs. Each IC has five pins on all four sides of the chip.

1 MB SIMMs

The 1 MB SIMMs also have eight ICs, but each IC has ten pins on only two sides of the chip.

WARNING: *You must use 120 ns 256K and 1 MB SIMMs on the NTX I/O board. The 150 ns SIMMs will cause serious timing problems.*



)

)

)



LaserWriter II

Section 8 – Appendix

□ CONTENTS

Photo #1:	Print Engine with Top Cover Removed
Photo #2:	Print Engine with Top Cover Removed
Photo #3:	Print Engine with Top Cover Open
Photo #4:	Lower Print Engine
LaserWriter II Wiring Diagram	



□ PRINT ENGINE WITH TOP COVER REMOVED – PHOTO #1

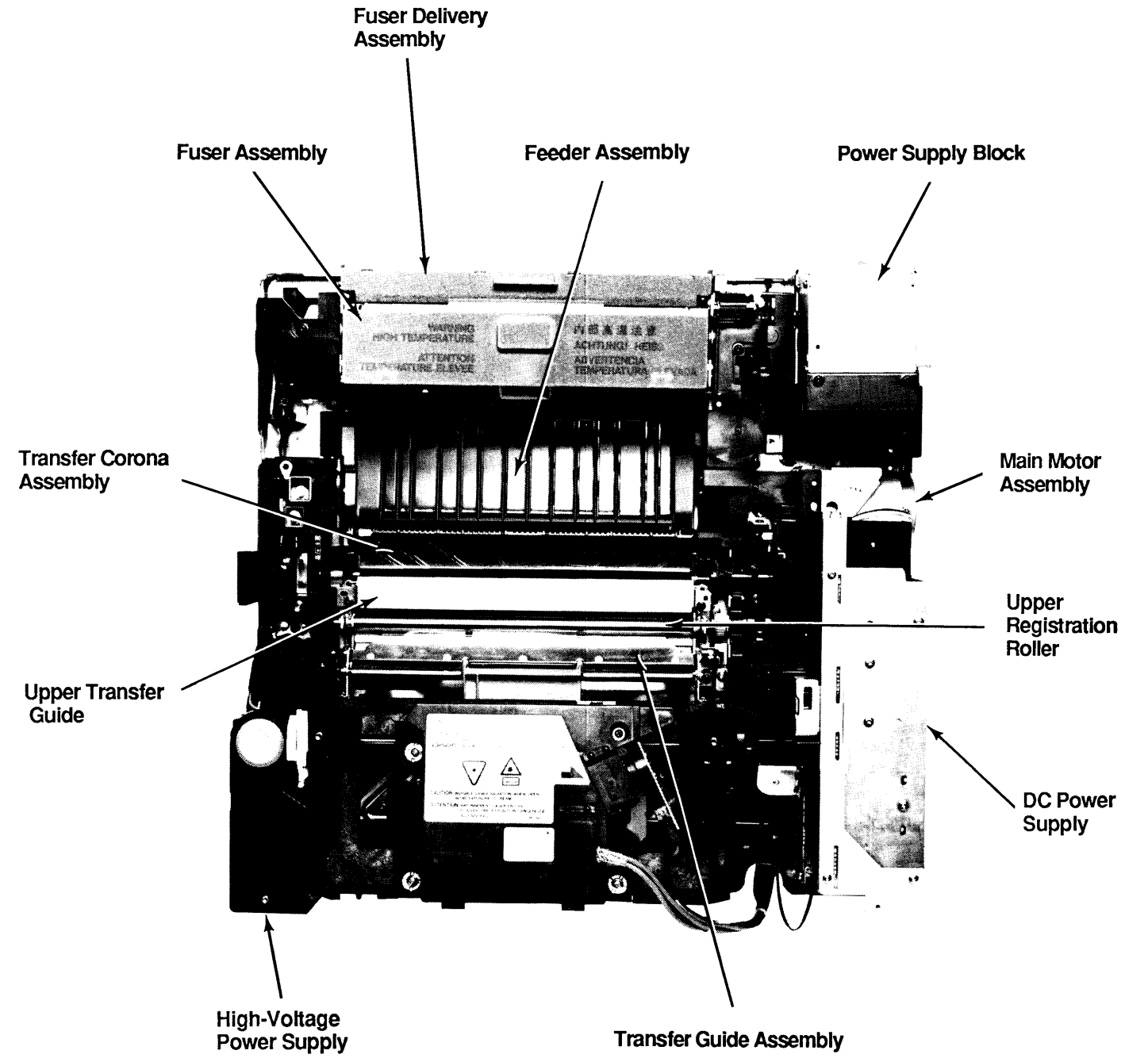

Print Engine with Top Cover Removed

□ PRINT ENGINE WITH TOP COVER REMOVED – PHOTO #2

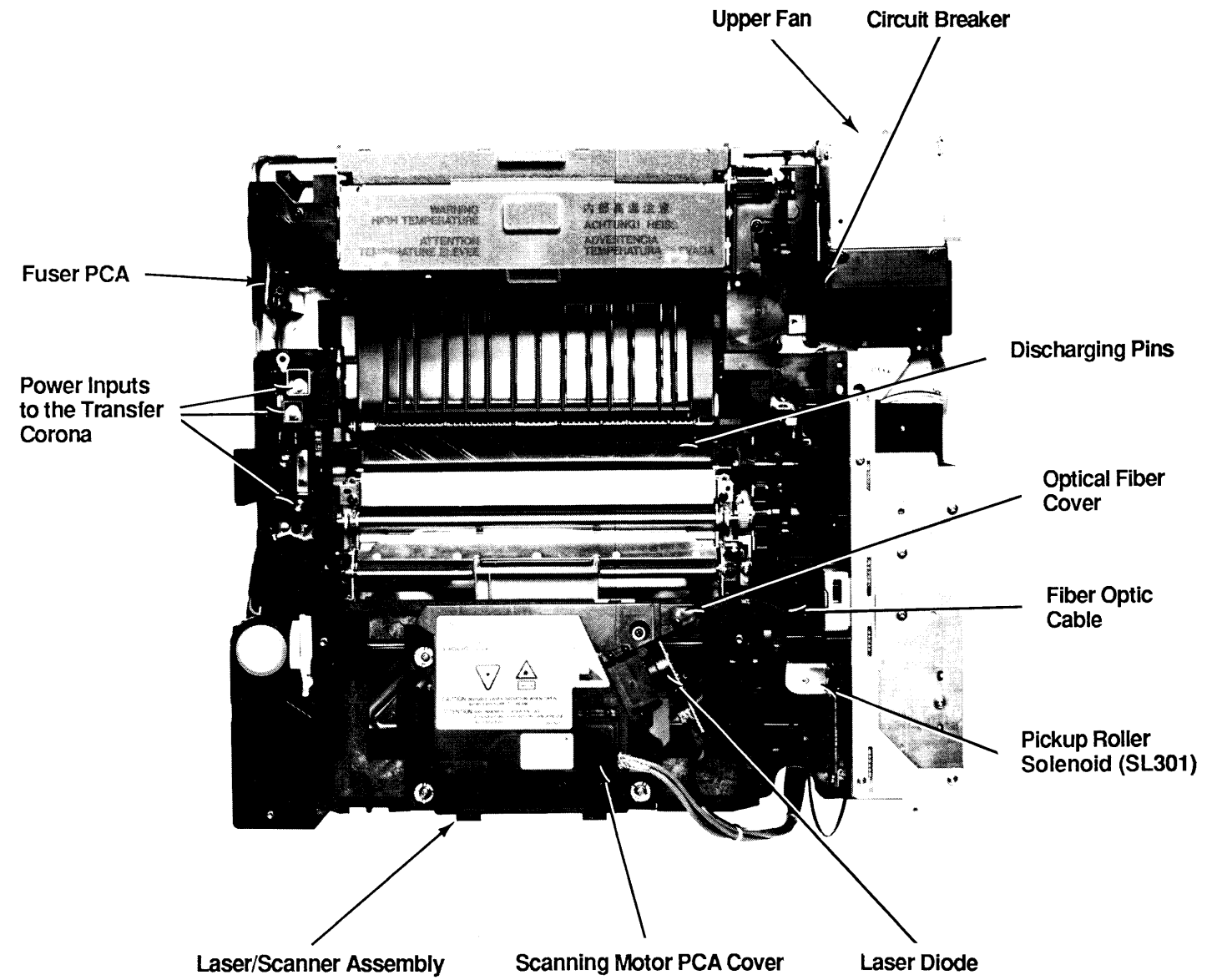

Print Engine with Top Cover Removed

□ PRINT ENGINE WITH TOP COVER OPEN – PHOTO #3

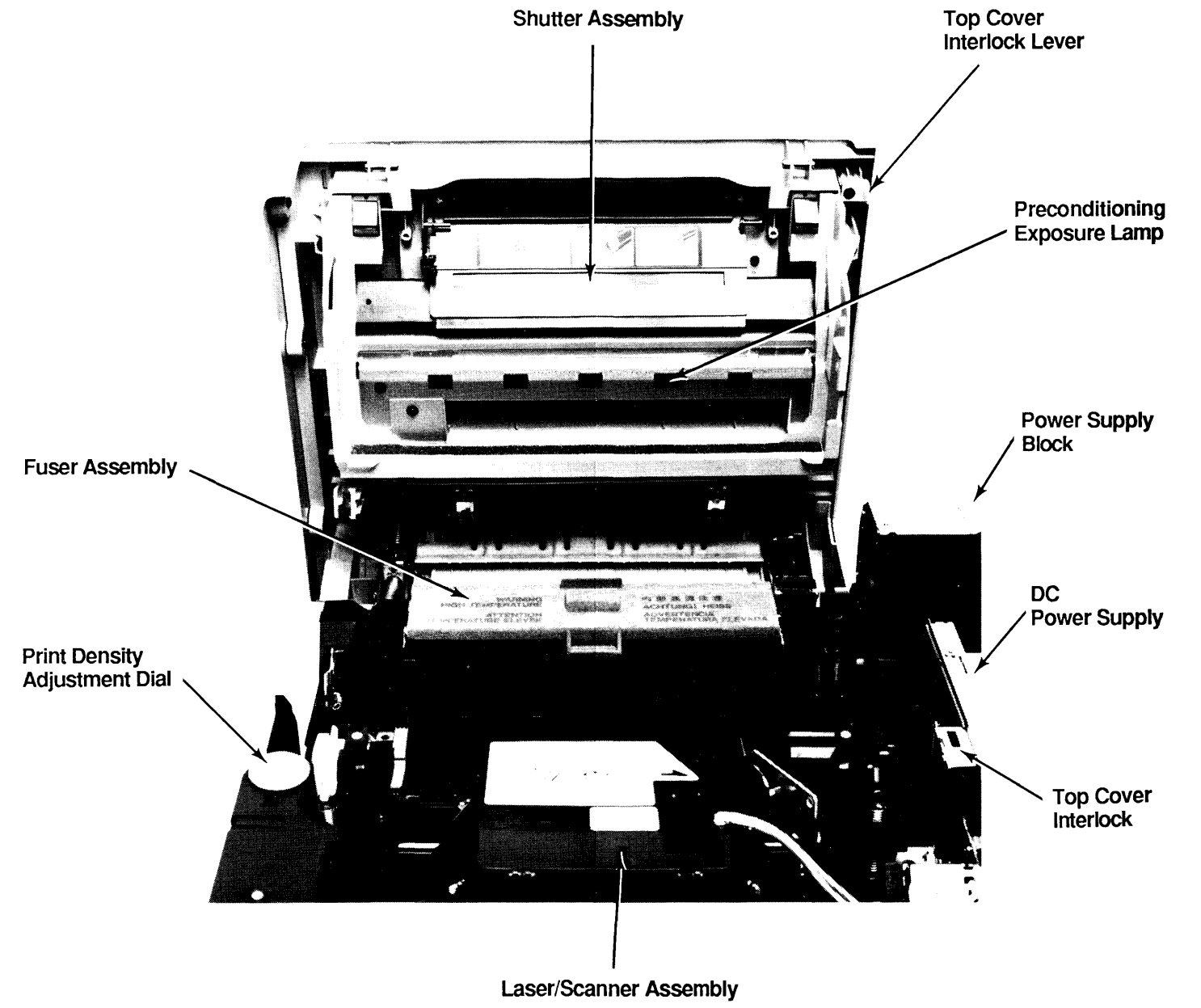

Print Engine with Top Cover Open

□ LOWER PRINT ENGINE – PHOTO #4

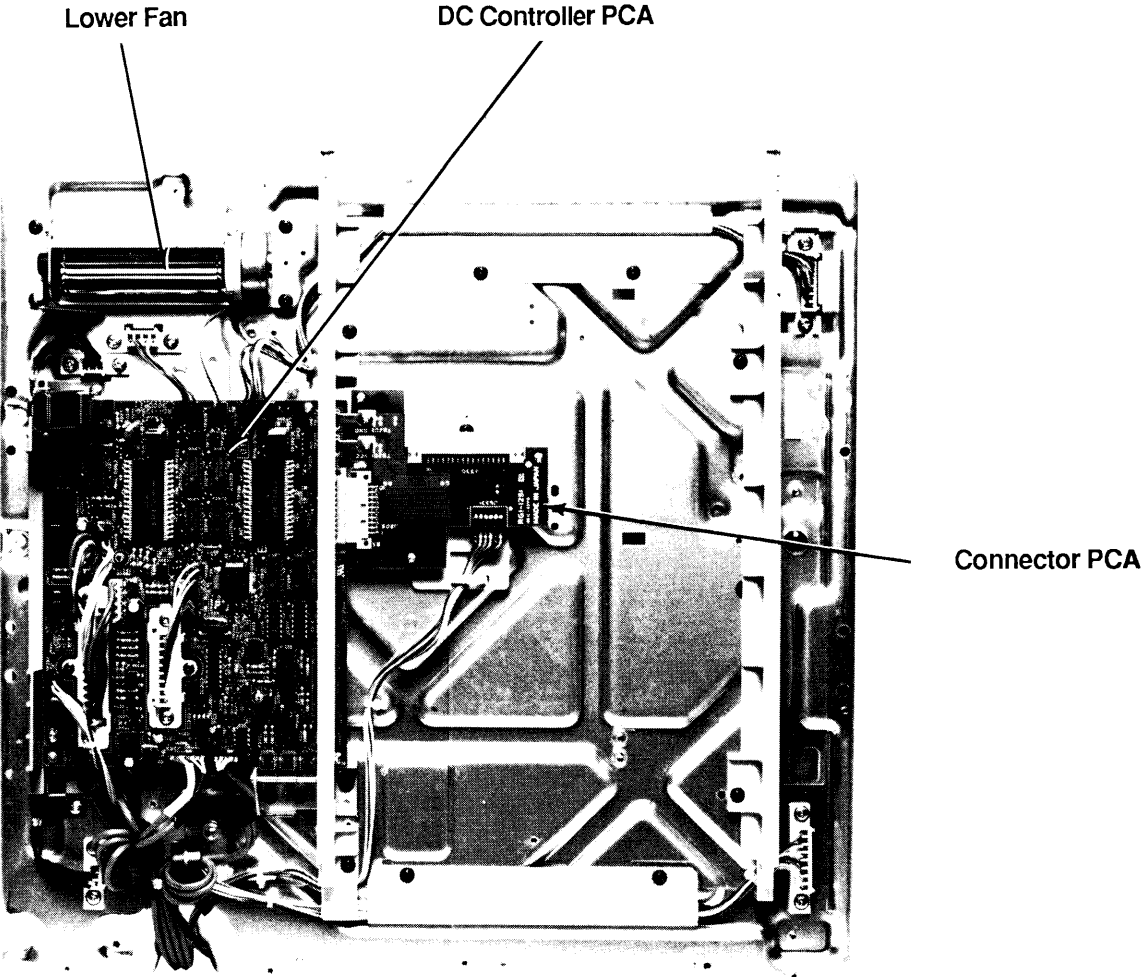

Lower Print Engine

□ LASERWRITER II WIRING DIAGRAM

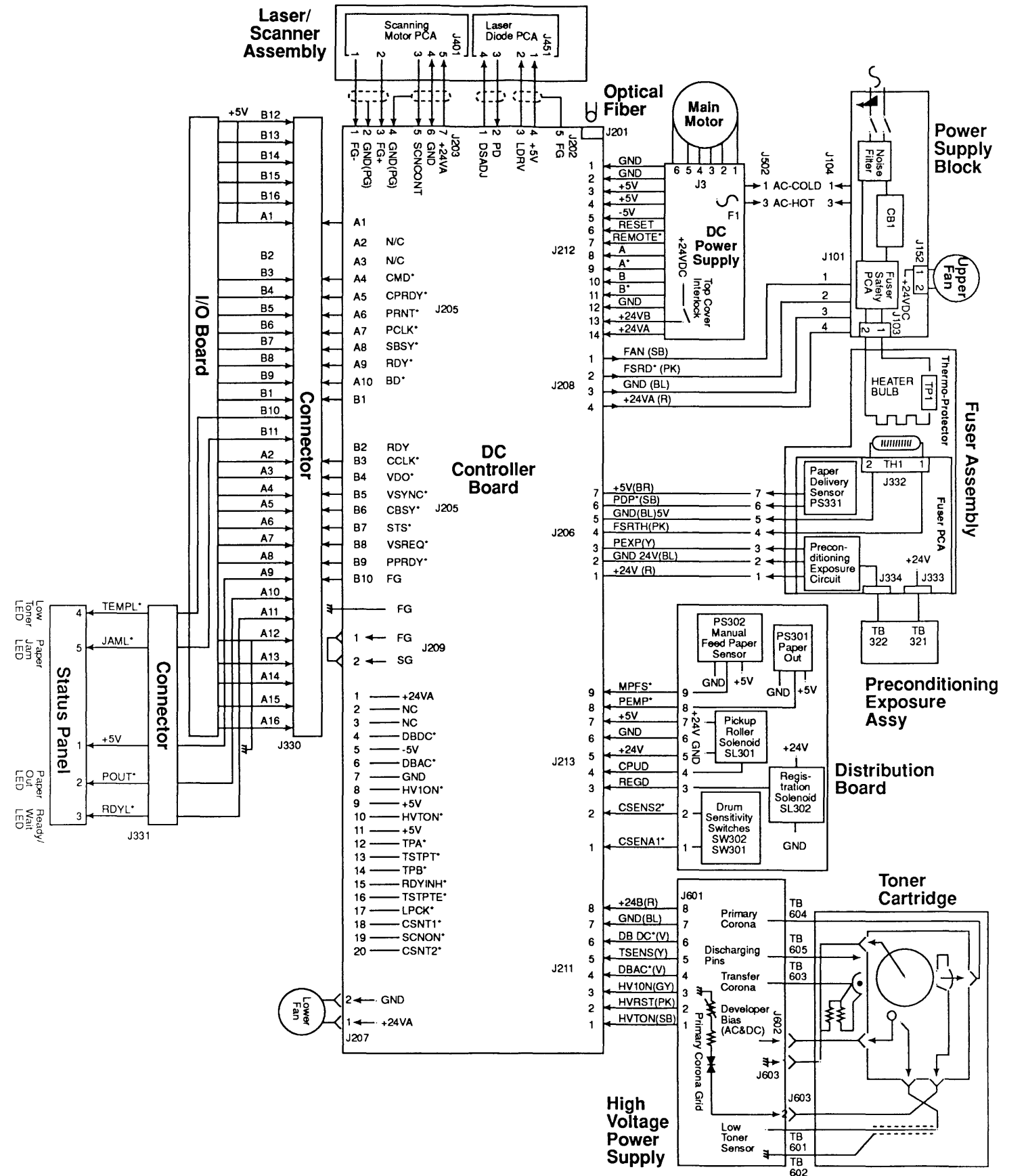

)

)

)



LaserWriter II

Illustrated Parts List

□ CONTENTS

- IPL.3 External Panels (Figure 1)
- IPL.5 Main Body (Figure 2)
- IPL.7 Upper Main Body (Figure 3)
- IPL.9 Bottom Case, #1 (Figure 4)
- IPL.11 Bottom Case, #2 (Figure 5)
- IPL.13 Power Cord Terminal Assembly (Figure 6)
- IPL.15 Pressure Assembly (Figure 7)
- IPL.17 Hinge Assembly (Figure 8)
- IPL.17 Gear Drive Assembly (Figure 9)
- IPL.19 Paper Feed Drive Assembly (Figure 10)
- IPL.19 Main Motor Assembly (Figure 11)
- IPL.21 Shutter Assembly (Figure 12)
- IPL.23 Cassette Holder Assembly (Figure 13)
- IPL.25 Paper Feed Roller Assembly (Figure 14)
- IPL.25 Feeder Assembly (Figure 15)
- IPL.27 Transfer Guide Assembly (Figure 16)
- IPL.29 Fixing Delivery Assembly (Figure 17)
- IPL.29 Delivery Coupler Assembly (Figure 18)
- IPL.31 Transfer Corona Assembly (Figure 19)
- IPL.33 Fuser Assembly, Top View (Figure 20)
- IPL.35 Fuser Assembly, Exploded View #1 (Figure 21)
- IPL.37 Fuser Assembly, Exploded View #2 (Figure 22)
- IPL.39 Electrical Components Assembly (Figure 23)
- IPL.41 High-Voltage Power Supply (Figure 24)
- IPL.42 Refurbishment Kit
- IPL.43 Spring Kit
- IPL.45 LW II NTX Controller-I/O Board (Figure 25)
- IPL.45 LW II NTX Controller-I/O Board (rev. 3) (Figure 25)
- IPL.47 LW II NT Controller-I/O Board (Figure 26)
- IPL.49 Cables (Figure 27)
- IPL.49 Screw Kit
- IPL.51 LW Iif Controller-I/O Board (Figure 28)
- IPL.51 LW IIg Controller-I/O Board (Figure 29)

The figures and lists in this section include all piece parts available from Apple for the LaserWriter II, along with their part numbers. These are the only parts available from Apple. Refer to your *Apple Service Programs* manual for prices.

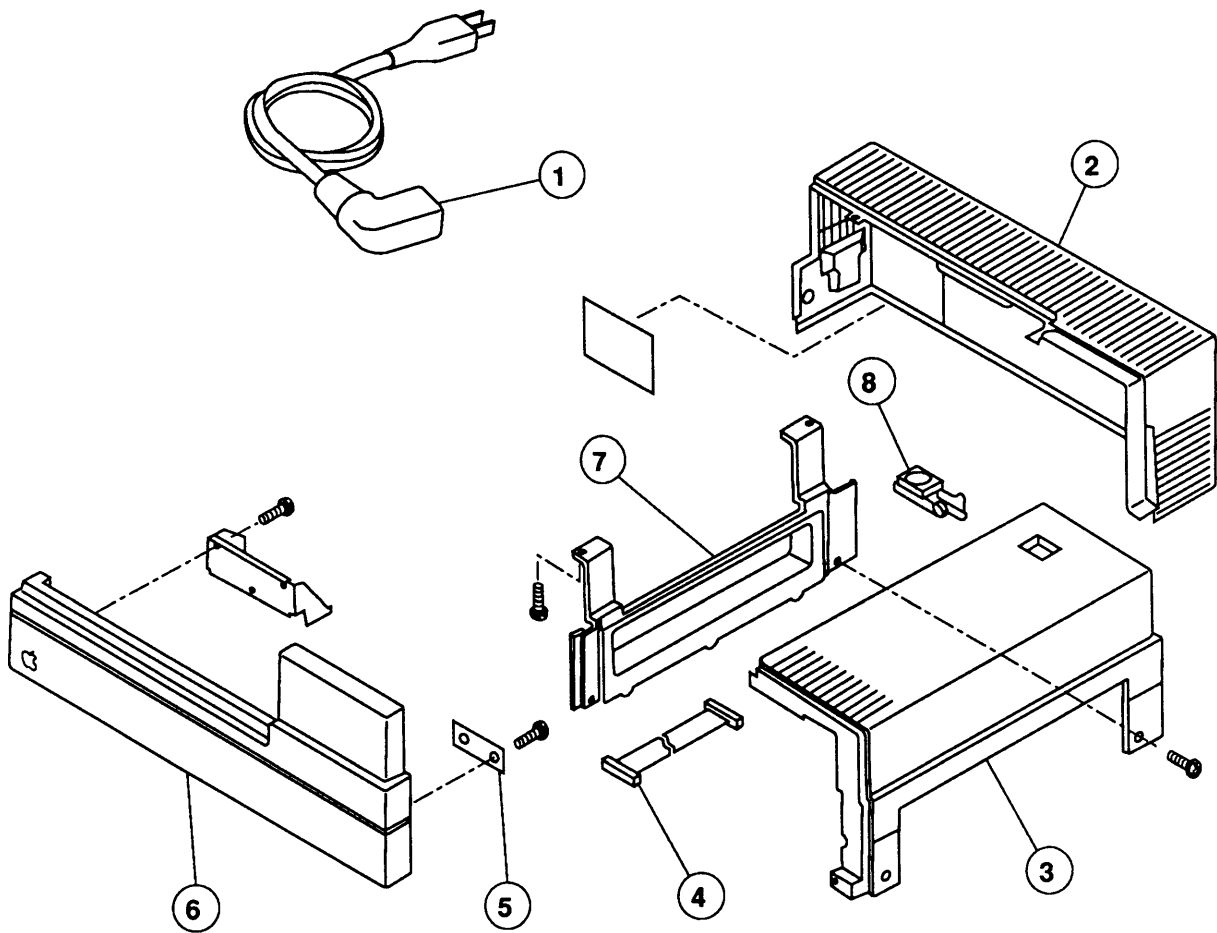

FIGURE 1

□ EXTERNAL PANELS (Figure 1)

<u>Item</u>	<u>Part No.</u>	<u>Description</u>
1	590-0380	AC Power Cable
2	949-0218	Rear Panel
3	949-0004	Upper Right Panel
4	936-0041	Status Panel Cable
5	971-0005	Status Panel
6	949-0219	Front Panel
7	949-0003	Lower Right Panel
8	949-0142	Release Button

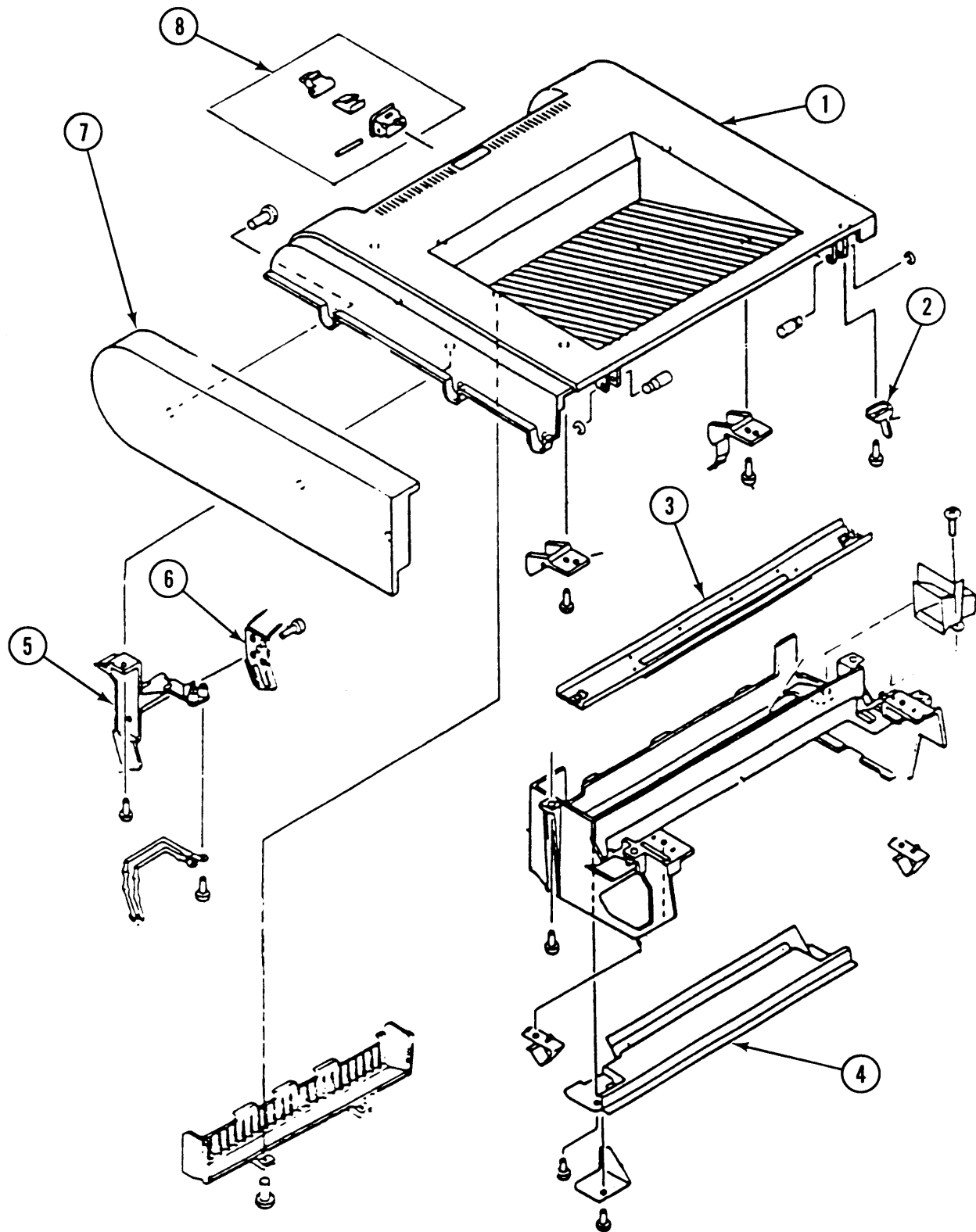

FIGURE 2

□ MAIN BODY (Figure 2)

<u>Item</u>	<u>Part No.</u>	<u>Description</u>
1	949-0144	Panel, Upper
2	949-0182	Lever, Top Cover InterLock
3	971-0007	Mirror Assembly
4	971-0025	Pre-Cond. Exp. Lamp Assembly
5	949-0184	Arm, Preconditioning Assembly
6	949-0183	Cover, Grounding
7	949-0148	Panel, Upper Front
8	983-0012	Latch, Magnetic Holder

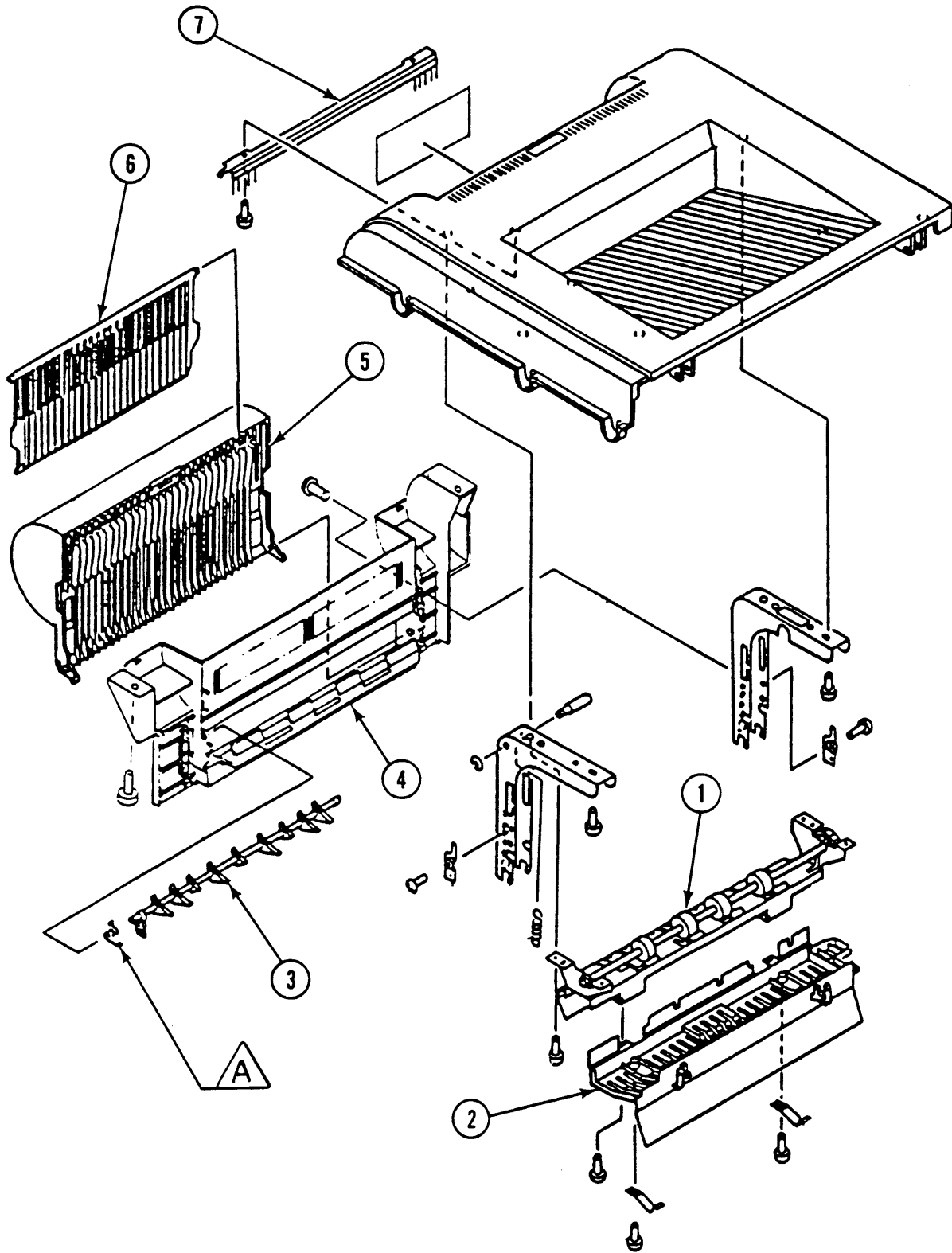

FIGURE 3

□ UPPER MAIN BODY (Figure 3)

<u>Item</u>	<u>Part No.</u>	<u>Description</u>
1	971-0023	Delivery Assembly
2	949-0143	Heater Cover
3	971-0006	Paper Deflector
4	949-0147	Copy Tray
5	949-0145	Main Tray
6	949-0146	Auxiliary Tray
7	970-0046	Static Charge Eliminator

Note: The following part shown in this diagram is available as part of the Spring Kit:

A Paper Deflector Spring (5/pk)

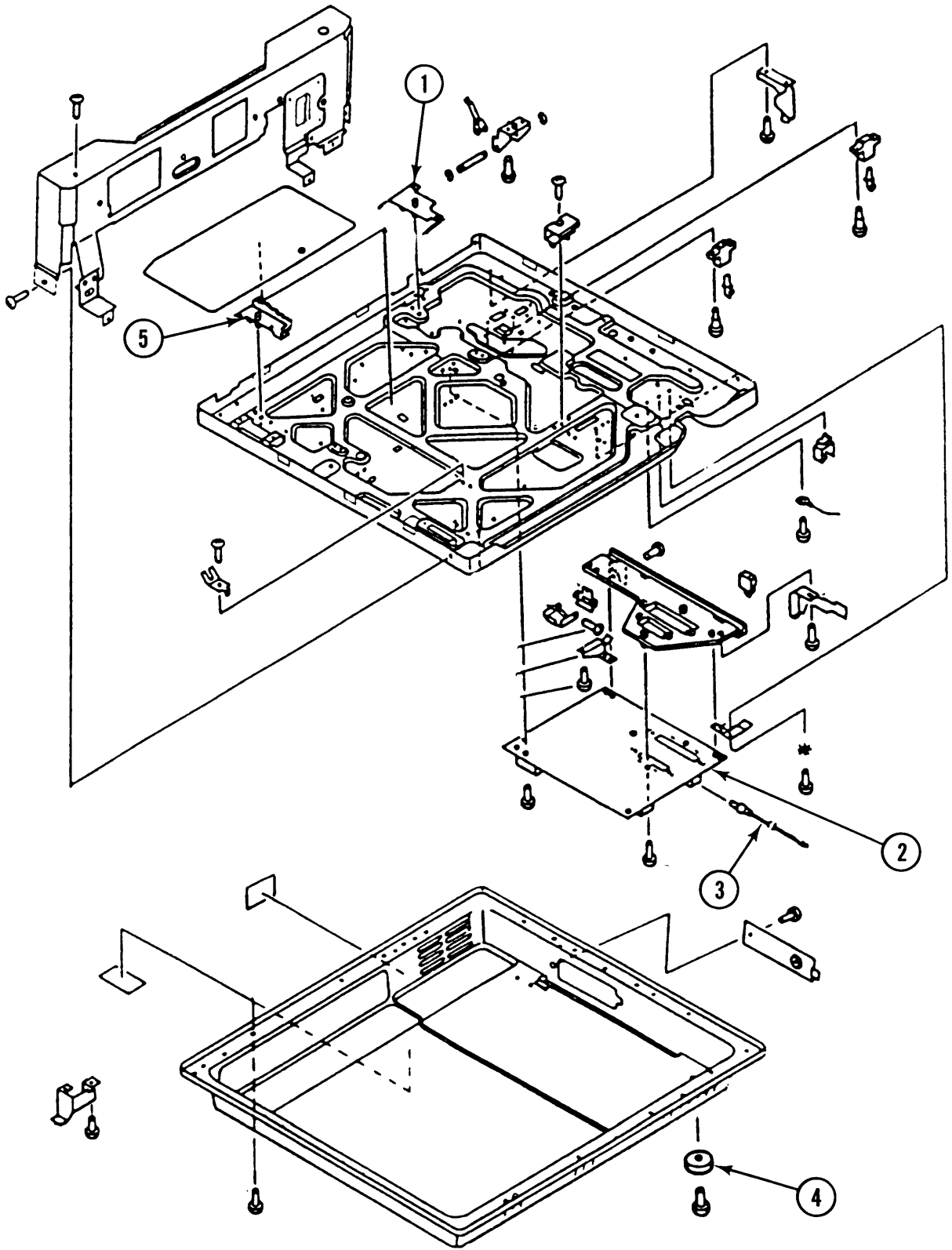

FIGURE 4

□ BOTTOM CASE, #1 (Figure 4)

<u>Item</u>	<u>Part No.</u>	<u>Description</u>
1	949-0150	Plate Pin, Right, Fusing Assembly
2	661-0426	DC Controller PCA
3	936-0042	Cable, Optical Fiber
4	956-0010	Foot, Rubber
5	949-0149	Plate Pin, Left, Fusing Assembly

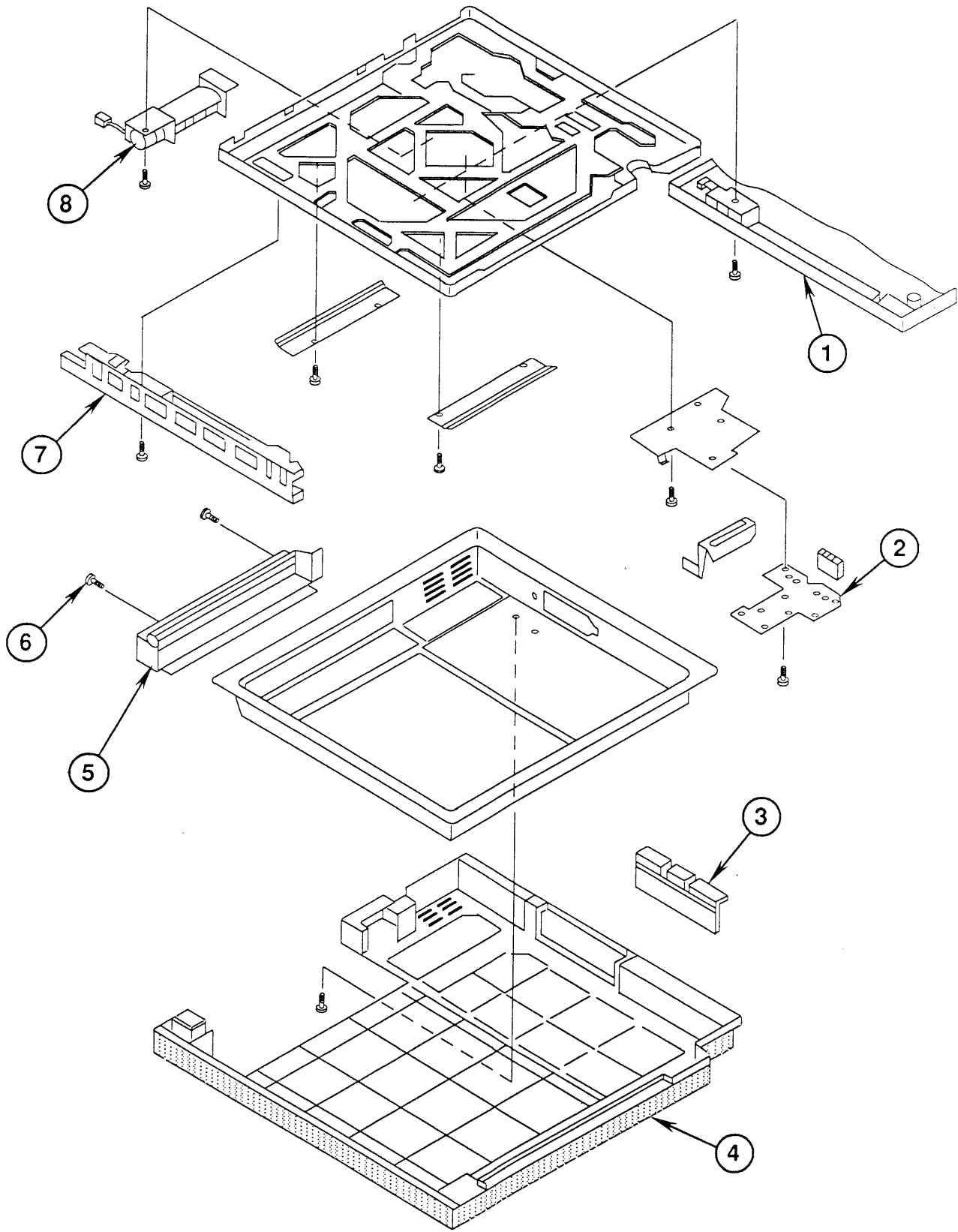

FIGURE 5

□ BOTTOM CASE, #2 (Figure 5)

<u>Item</u>	<u>Part No.</u>	<u>Description</u>
1	949-0153	Left Guide Rail
2	971-0008	Connector PCA
3	949-0154	Bottom Panel Cap
4	949-0152	Bottom Panel
5	948-0132	Grounding Bracket
6	931-0030	Screw, Capt. Shoulder, 3 x 0.5 mm (10/pk)
7	949-0151	Right Guide Rail
8	959-0021	Lower Fan

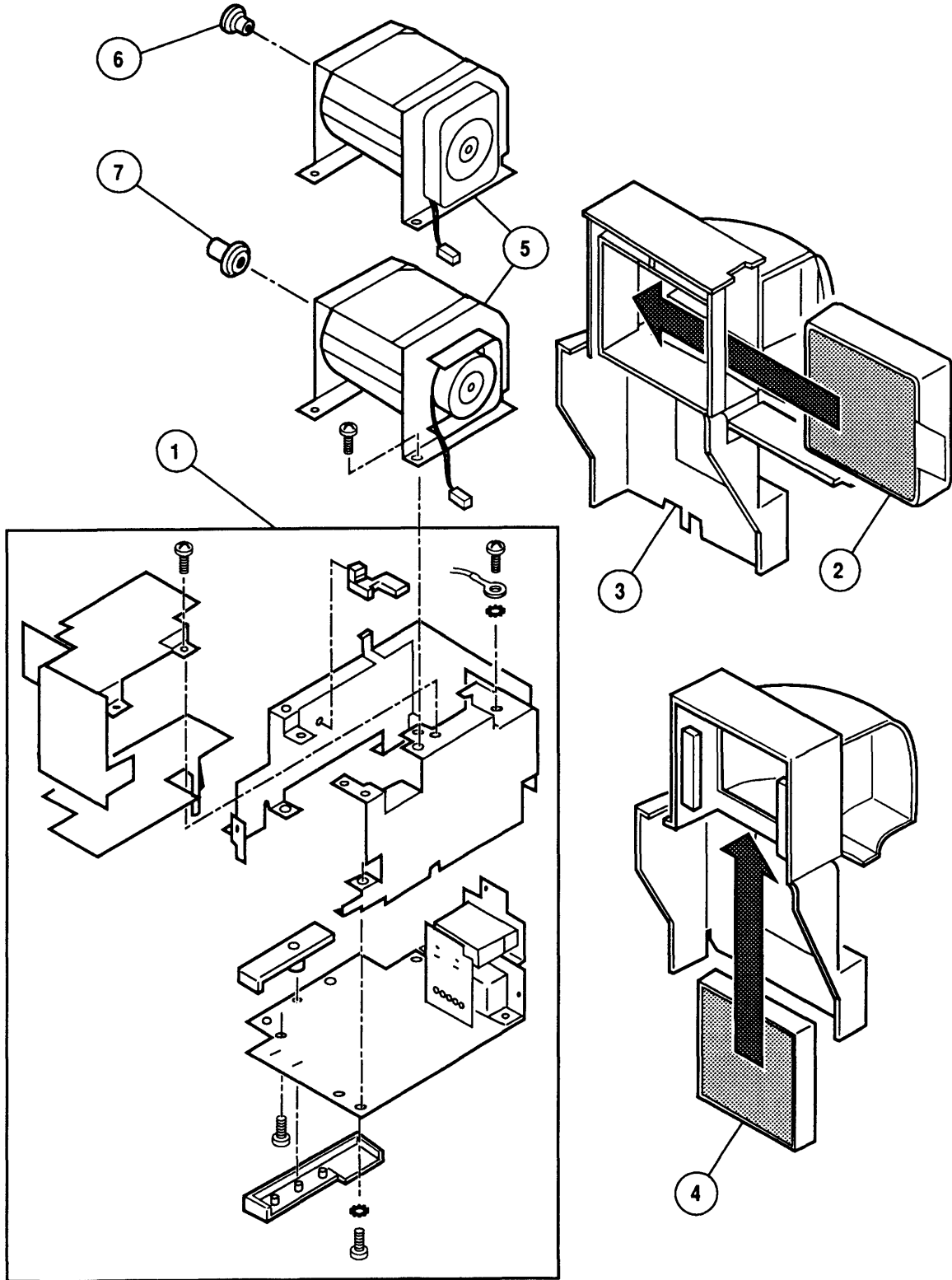

FIGURE 6

□ POWER CORD TERMINAL ASSEMBLY (Figure 6)

<u>Item</u>	<u>Part No.</u>	<u>Description</u>
1	661-0427	Power Supply Block, 110 V
	661-0443	Power Supply Block, 220/240 V
2	961-0007	Ozone Filter (for case with door)
3	971-0038	Ozone Filter Case with Door
4	961-0003	Ozone Filter
5	959-0022	Upper Fan
6	076-8130	Bushing/bearing, Type JP, 10/pk
7	076-8131	Bushing/bearing, Type T, 10/pk

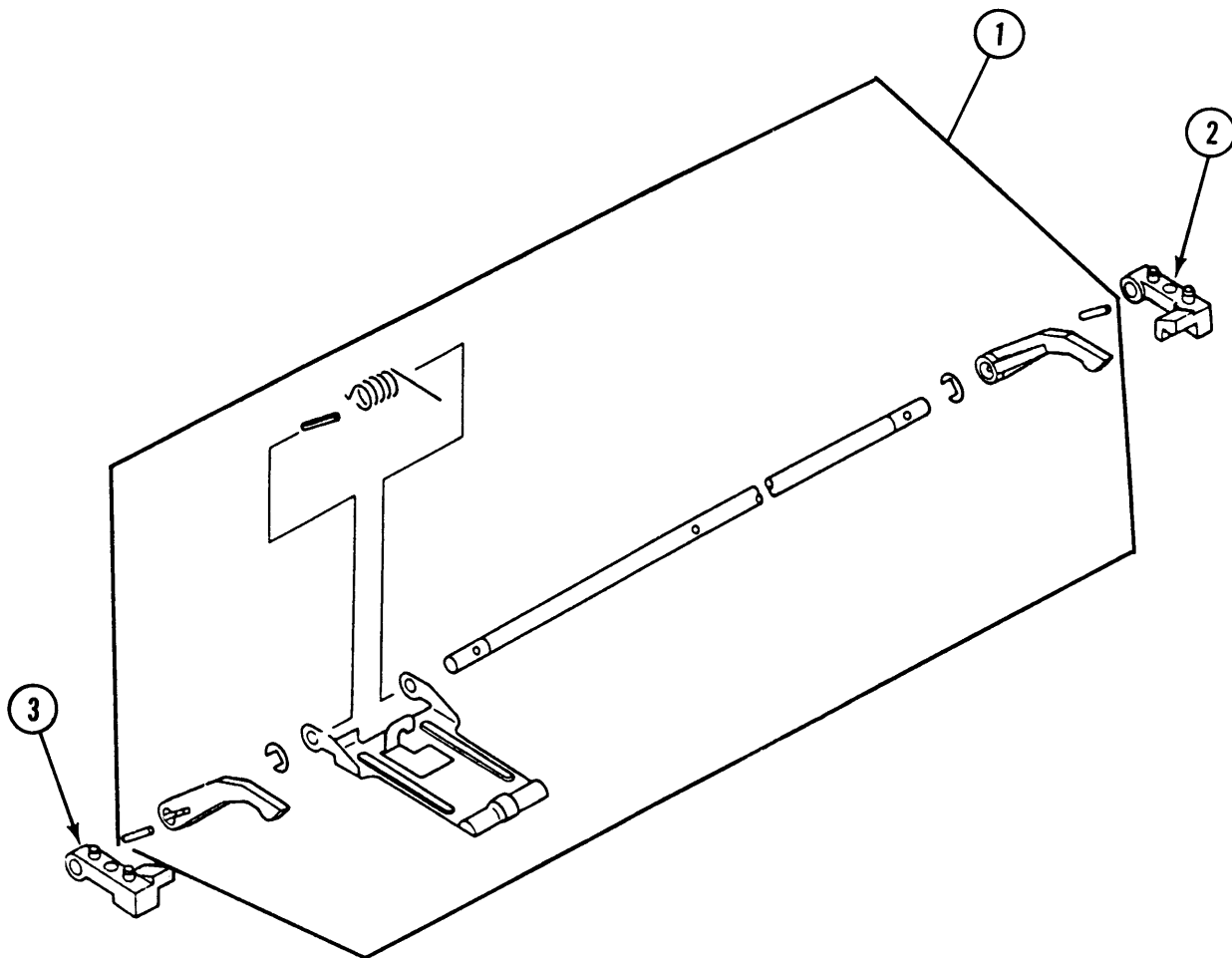

FIGURE 7

□ **PRESSURE ASSEMBLY (Figure 7)**

<u>Item</u>	<u>Part No.</u>	<u>Description</u>
1	971-0010	Pressure Assembly
2	949-0231	Cassette Stop, Right
3	949-0232	Cassette Stop, Left

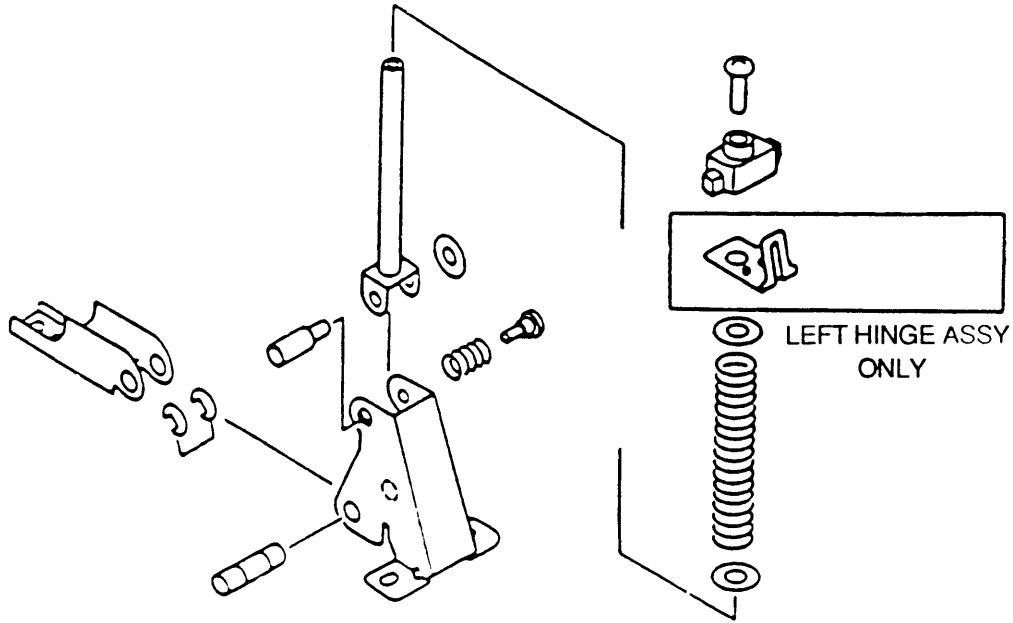

FIGURE 8

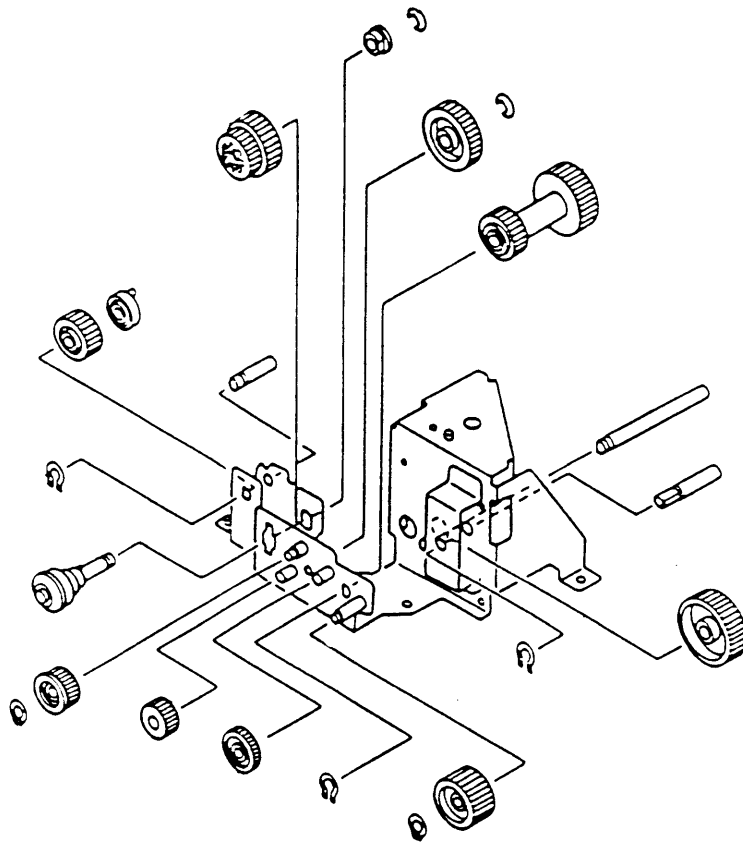

FIGURE 9

□ HINGE ASSEMBLY (Figure 8)

<u>Item</u>	<u>Part No.</u>	<u>Description</u>
-	971-0011	Hinge Assembly, Right
-	971-0012	Hinge Assembly, Left

□ DRIVE GEAR ASSEMBLY (Figure 9)

<u>Item</u>	<u>Part No.</u>	<u>Description</u>
-	971-0013	Drive Gear Assembly

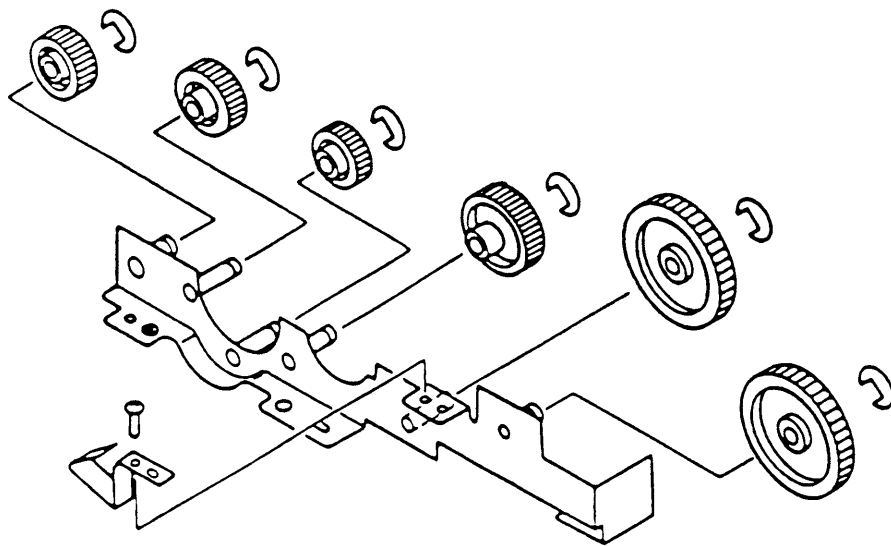

FIGURE 10

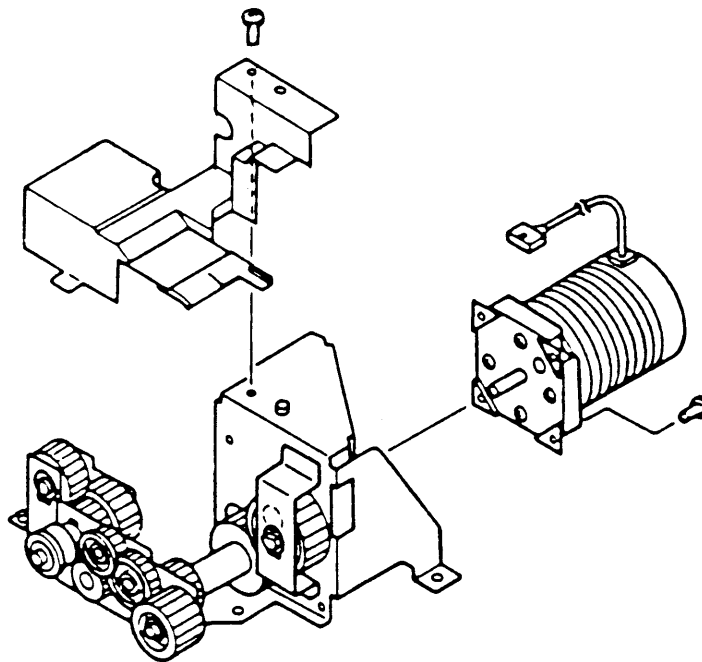

FIGURE 11

PAPER FEED DRIVE ASSEMBLY (Figure 10)

<u>Item</u>	<u>Part No.</u>	<u>Description</u>
-	971-0015	Paper Feed Drive Assembly

MAIN MOTOR ASSEMBLY (Figure 11)

<u>Item</u>	<u>Part No.</u>	<u>Description</u>
-	971-0014	Main Motor Assembly

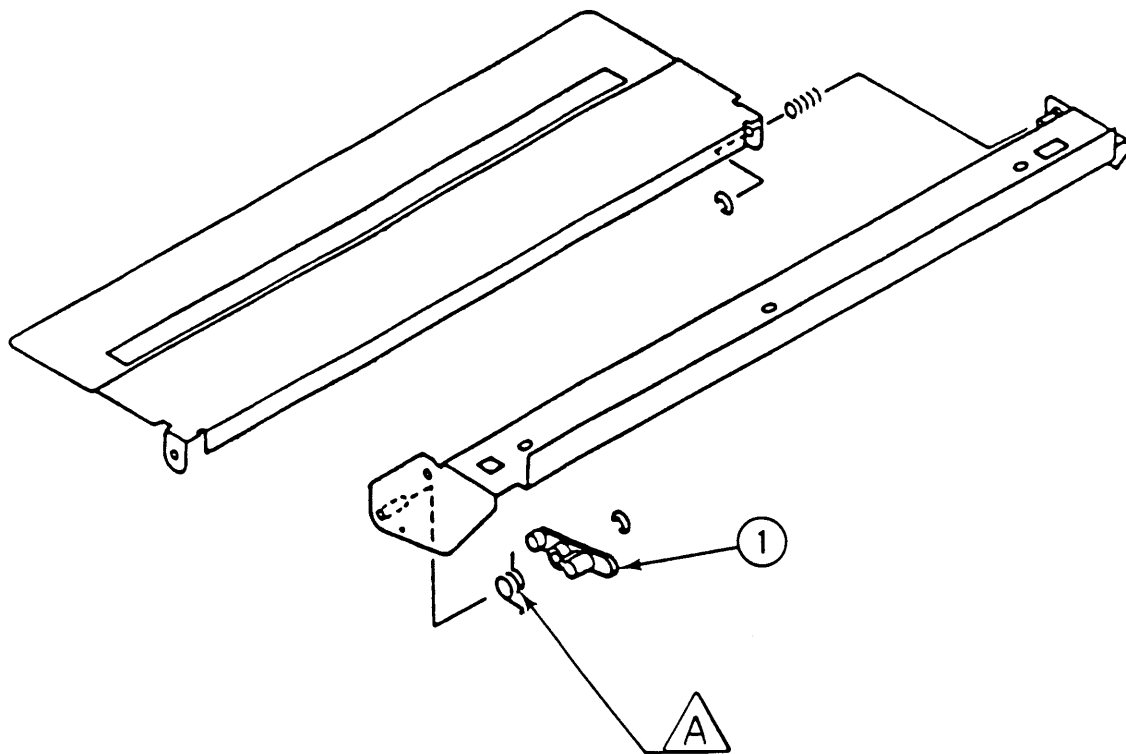

FIGURE 12

□ SHUTTER ASSEMBLY (Figure 12)

<u>Item</u>	<u>Part No.</u>	<u>Description</u>
-	971-0016	Shutter Assembly
1	949-0158	Arm

Note: Some of the parts shown in this diagram are available as part of the Spring Kit.

A Shutter Spring (5/pk)

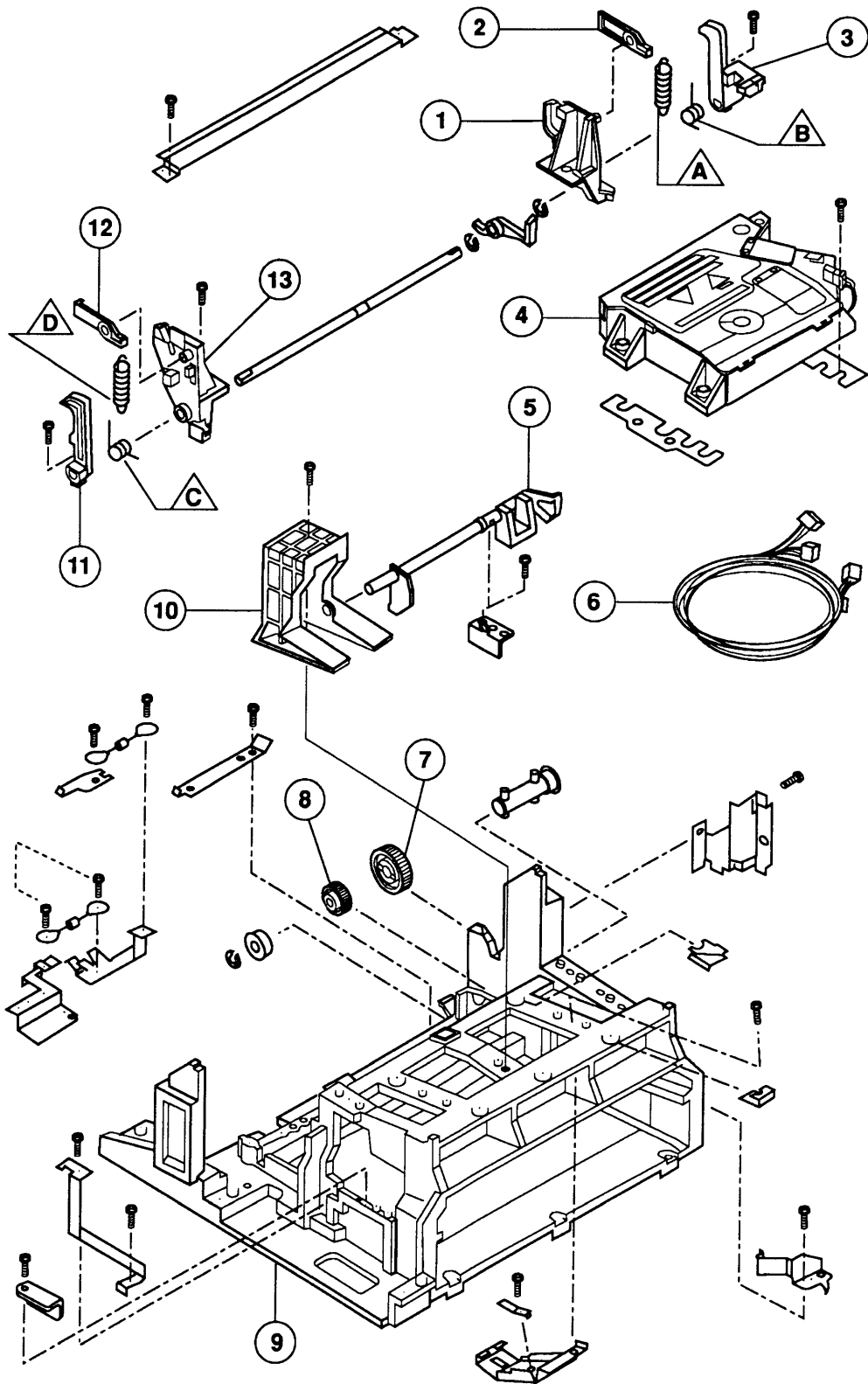

FIGURE 13

□ CASSETTE HOLDER ASSEMBLY (Figure 13)

<u>Item</u>	<u>Part No.</u>	<u>Description</u>
1	949-0162	Right Hook Guide
2	949-0164	Right Lifter
3	949-0160	Right Hook
4	661-0423	Laser/Scanner Assembly
5	949-0166	Paper Sensing Arm
6	936-0048	Laser Harness Cable
7	939-0024	Gear, 57T, Paper Pickup
8	939-0023	Gear, 19T, Paper Pickup
9	949-0247	Main Body Block
10	949-0165	Auxiliary Guide
11	949-0159	Left Hook
12	949-0163	Left Lifter
13	949-0161	Left Hook Guide

Note: Some of the parts shown in this diagram are available as part of the Spring Kit.

- A Right Lifter Spring (5/pk)
- B Right Hook Spring (5/pk)
- C Left Hook Spring (5/pk)
- D Left Lifter Spring (5/pk)

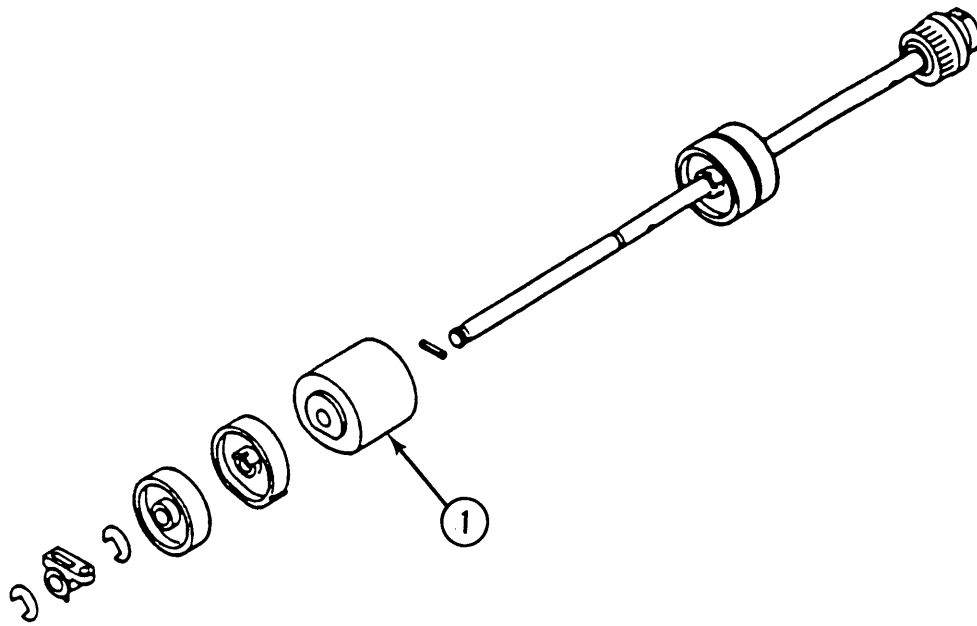

FIGURE 14

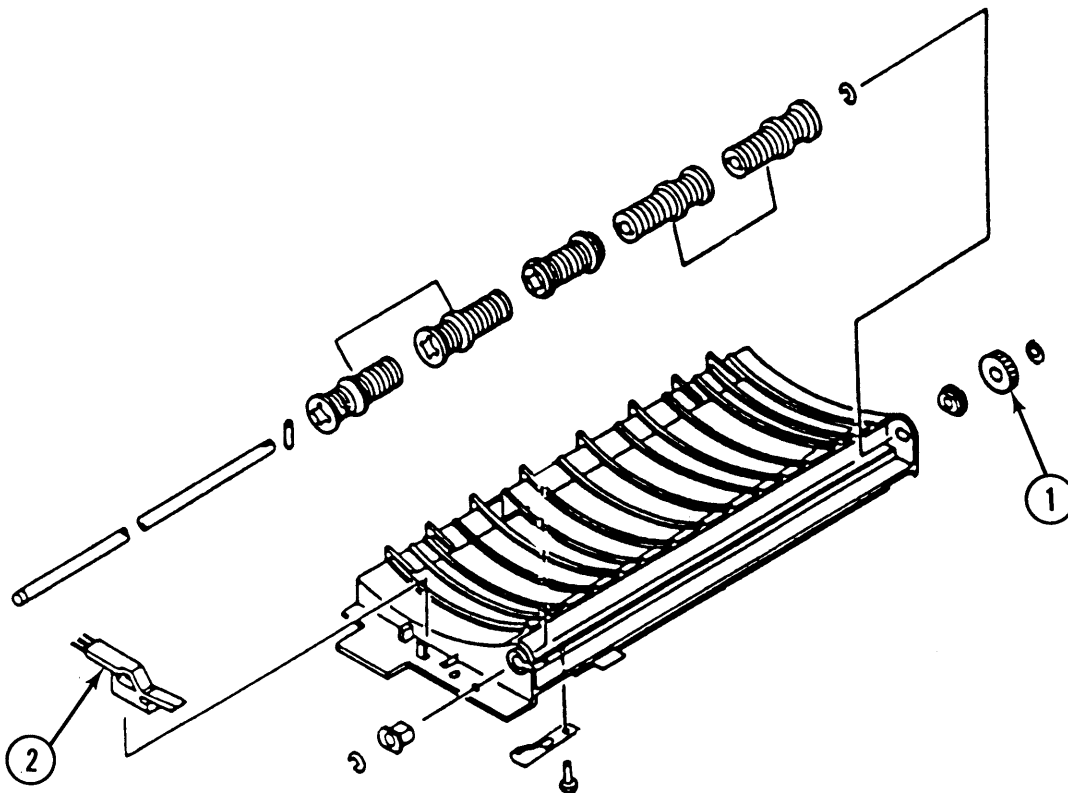

FIGURE 15

PAPER FEED ROLLER ASSEMBLY (Figure 14)

<u>Item</u>	<u>Part No.</u>	<u>Description</u>
-	971-0017	Paper Feed Assembly
1	959-0023	Roller, Pickup

FEEDER ASSEMBLY (Figure 15)

<u>Item</u>	<u>Part No.</u>	<u>Description</u>
-	971-0018	Feeder Assembly
1	939-0025	Gear, 24T, Feeder Guide
2	970-0047	Cleaner Brush

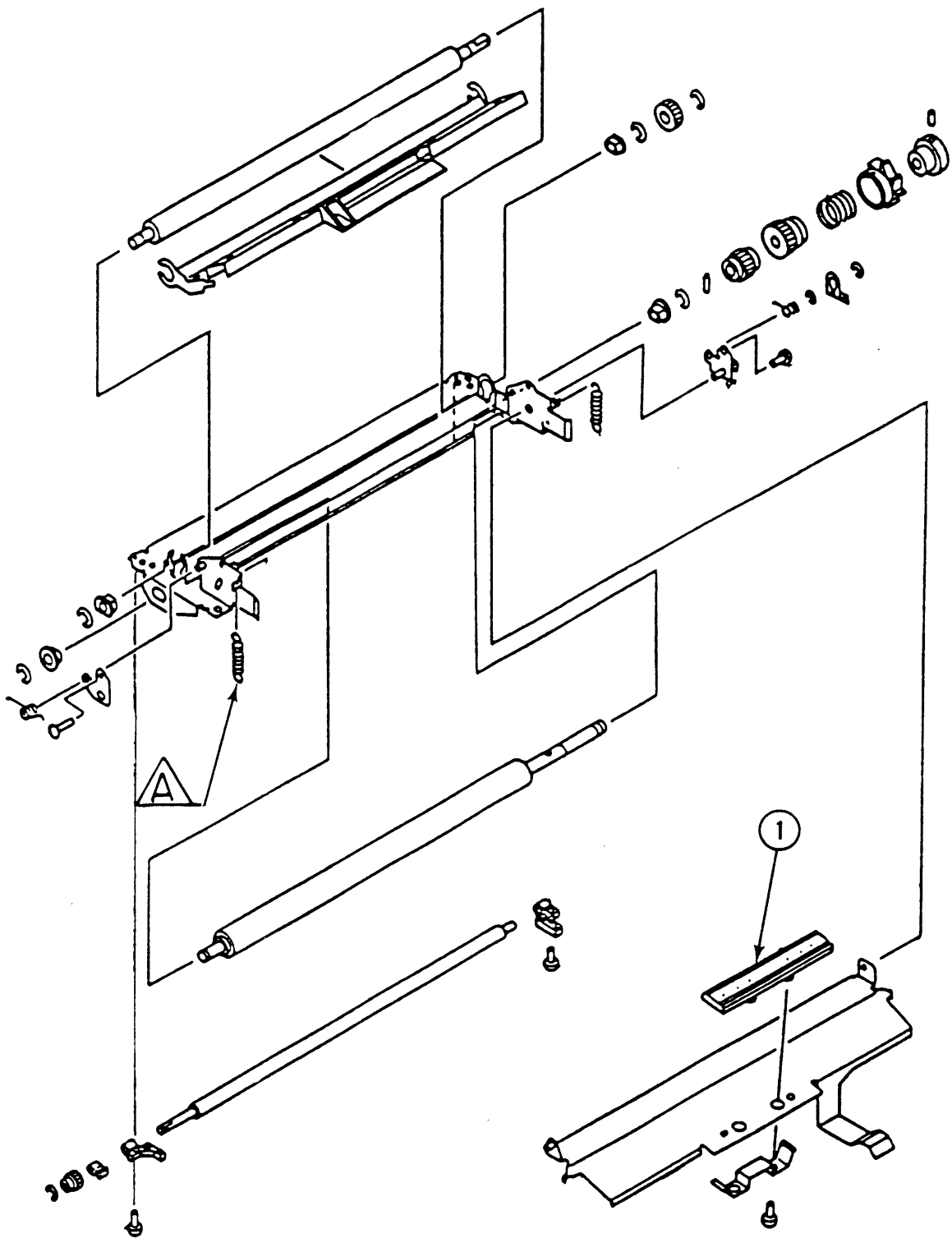

FIGURE 16

□ **TRANSFER GUIDE ASSEMBLY (Figure 16)**

<u>Item</u>	<u>Part No.</u>	<u>Description</u>
-	971-0019	Transfer Guide Assembly
1	970-0048	Separation Pad

Note: Some of the parts shown in this diagram are available as part of the Spring Kit.

A Transfer Guide Spring (5/pk)

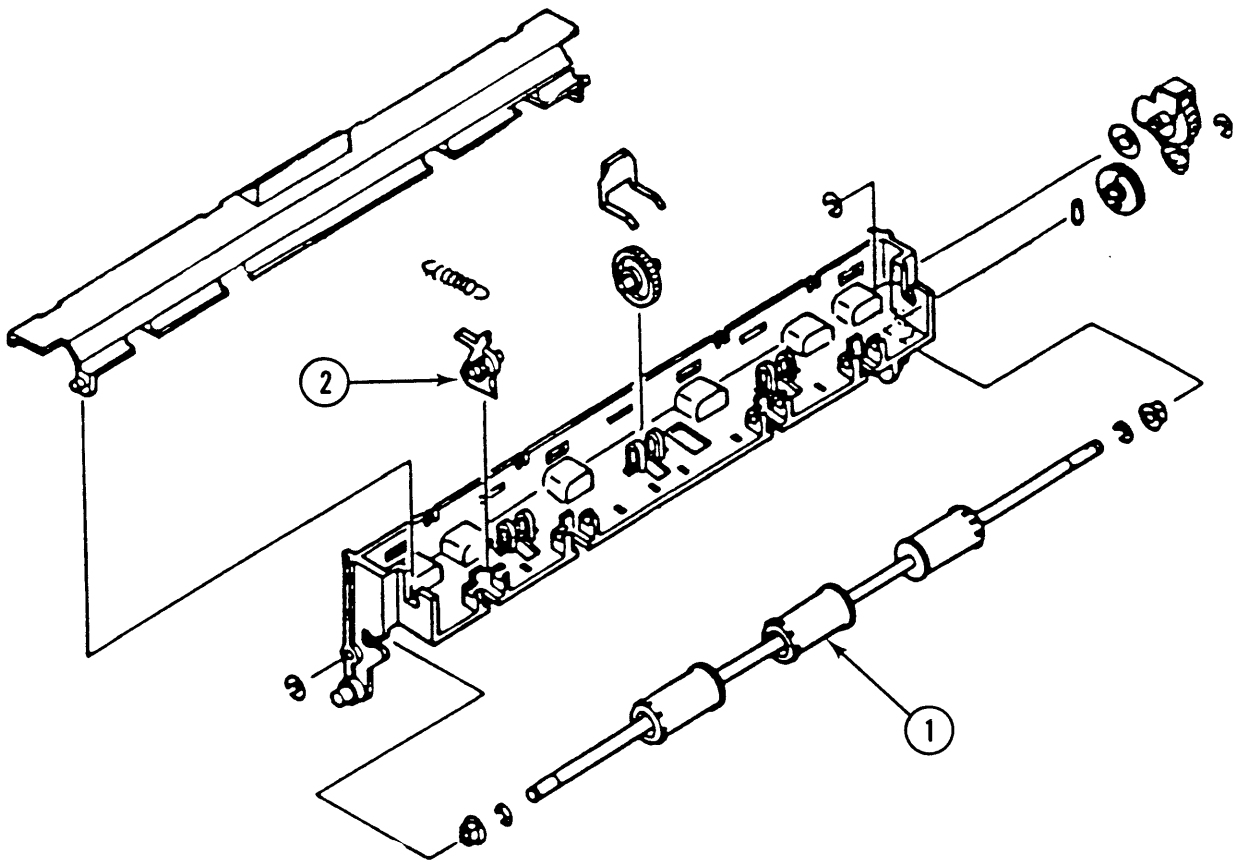

FIGURE 17

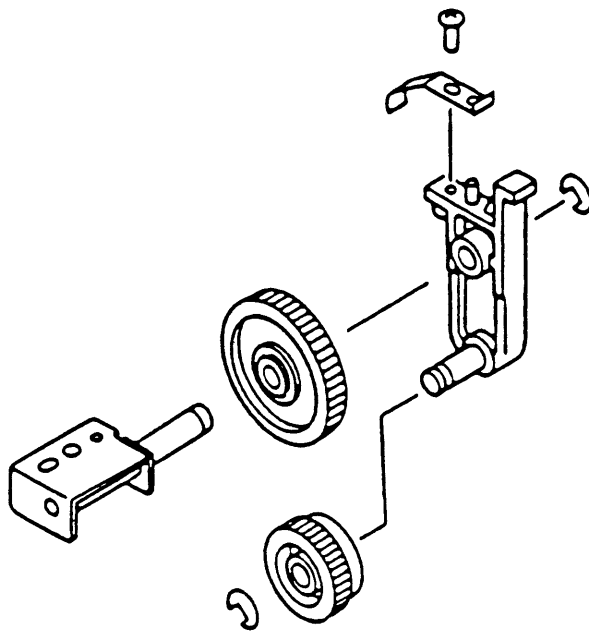

FIGURE 18

FIXING DELIVERY ASSEMBLY (Figure 17)

<u>Item</u>	<u>Part No.</u>	<u>Description</u>
-	971-0020	Fixing Delivery Assembly
1	971-0021	Delivery Roller
2	076-8414	Claw, Separation, Fuser Assembly (10/pk)

DELIVERY COUPLER ASSEMBLY (Figure 18)

<u>Item</u>	<u>Part No.</u>	<u>Description</u>
-	971-0022	Delivery Coupler Assembly

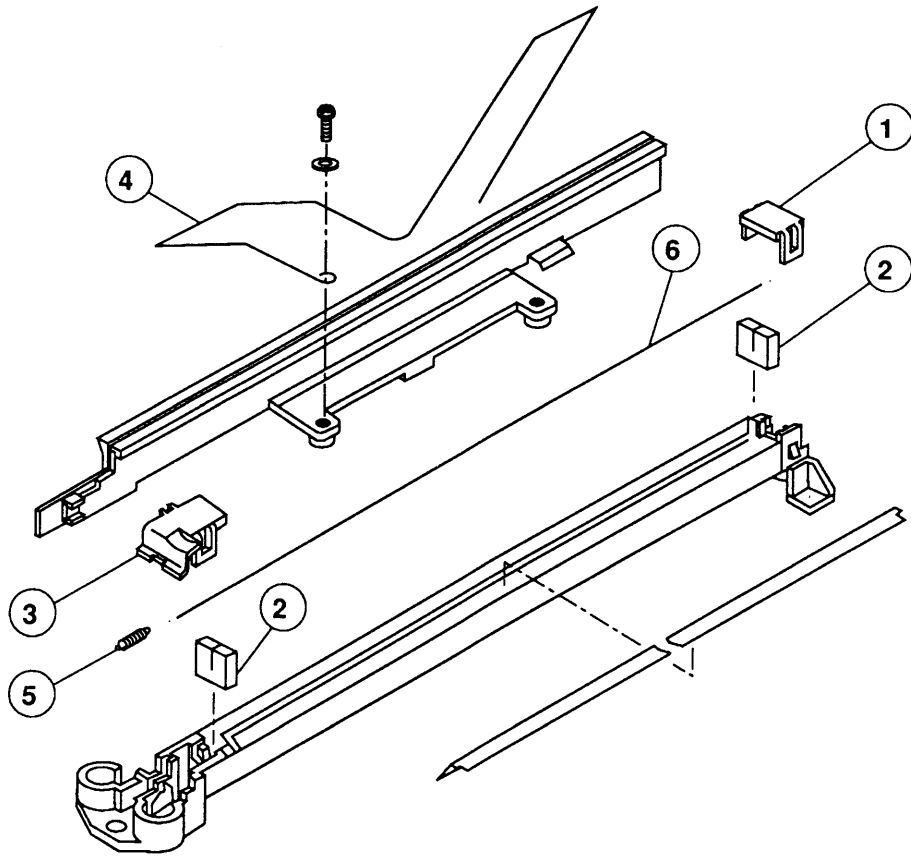

FIGURE 19

□ **TRANSFER CORONA ASSEMBLY (Figure 19)**

<u>Item</u>	<u>Part No.</u>	<u>Description</u>
-	971-0026	Transfer Corona Assembly
1	949-0167	Cover, Right
2	958-0007	Pad
3	949-0168	Cover, Left
4	935-0004	Lope, Guide
5	970-1036	Tension Spring, Corona Wire
6	076-8126	Corona Wire Set, 2 each

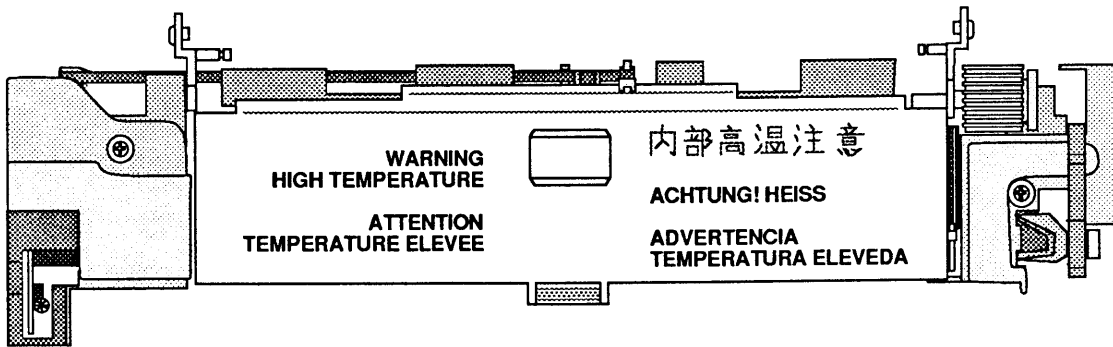

FIGURE 20

□ FUSER ASSEMBLY, TOP VIEW (Figure 20)

<u>Item</u>	<u>Part No.</u>	<u>Description</u>
-	661-0440	Fuser Assembly, 110 V
-	661-0444	Fuser Assembly, 220/240 V

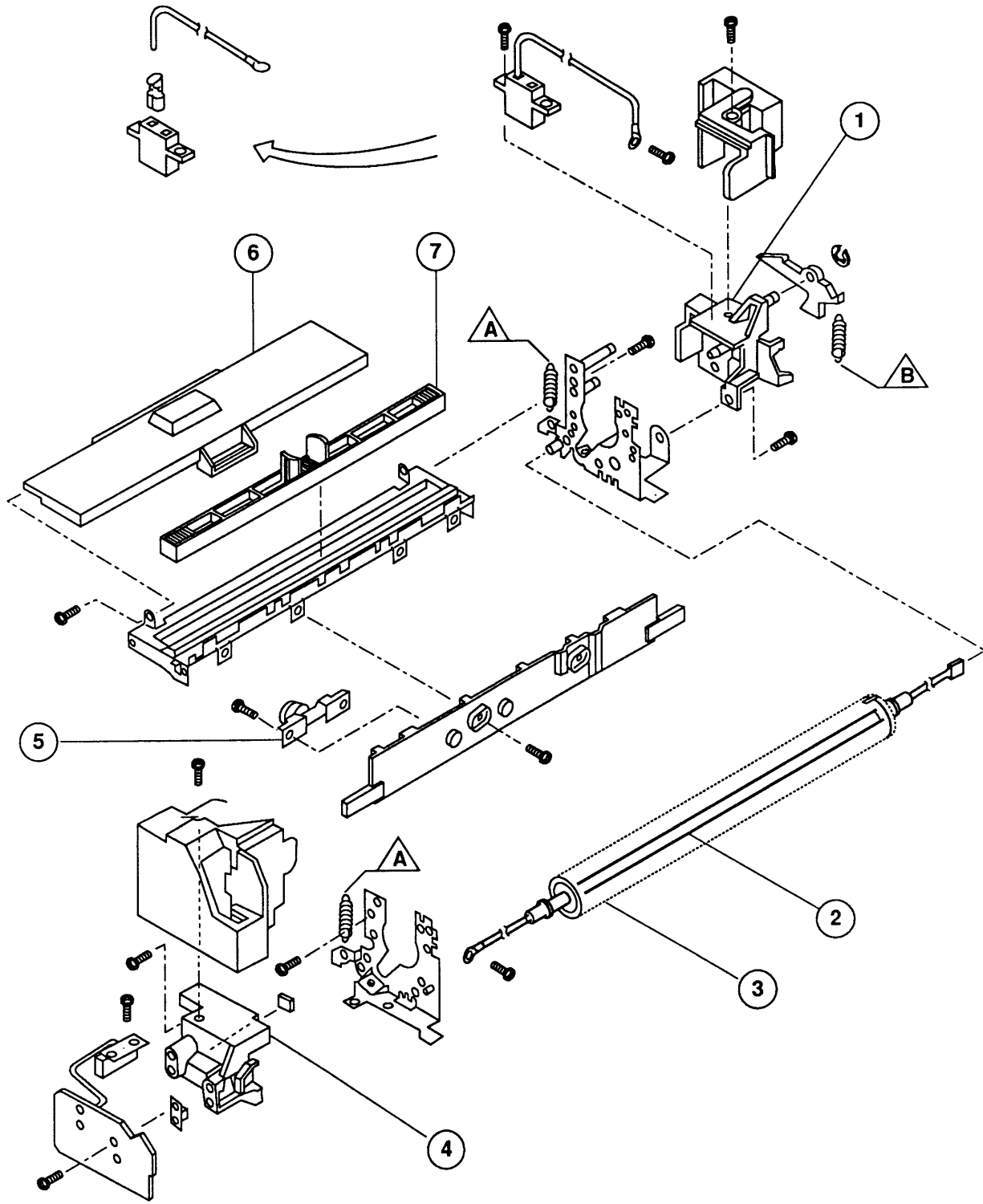

FIGURE 21

□ FUSER ASSEMBLY, EXPLODED VIEW #1 (Figure 21)

<u>Item</u>	<u>Part No.</u>	<u>Description</u>
1	949-0204	Holder, Right Heater Term
2	938-0003	Heater Bulb, 115 V, 620 W
	938-0004	Heater Bulb, 220 V, 570 W
3	947-0007	Roller, Upper, Fuser Assy, LaserWriter II
4	949-0203	Holder, Left Heater Term
5	925-0009	Thermosensor, 210° C, Fuser Assembly
6	970-1314	Fuser Lid
7	970-0049	Fuser Roller Cleaner

Note: Some of the parts shown in this diagram are available as part of the Spring Kit.

- A Fuser Spring (5/pk)
- B Fuser Cam Spring (5/pk)

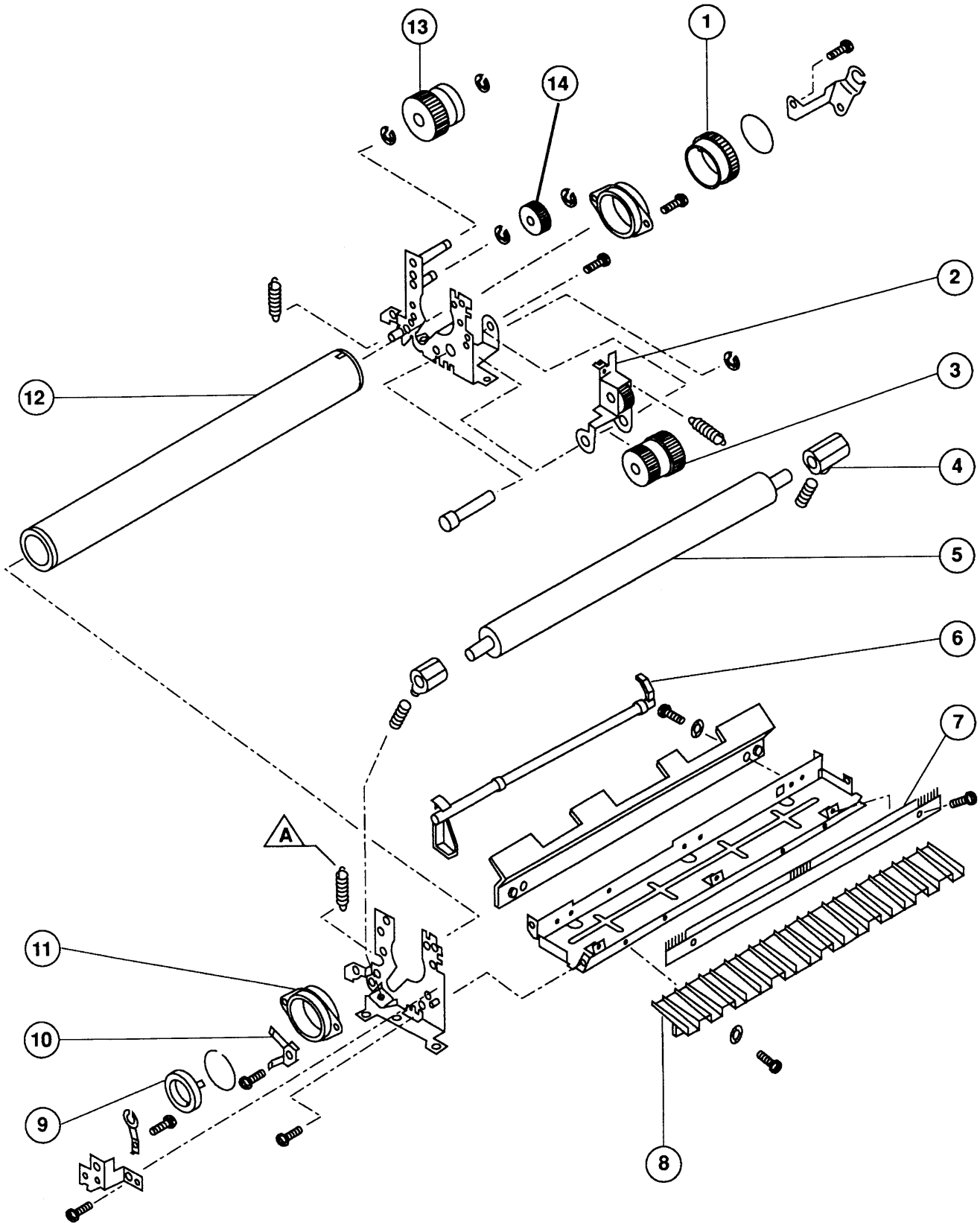

FIGURE 22

□ FUSER ASSEMBLY, PARTIAL EXPLODED VIEW #2 (Figure 22)

<u>Item</u>	<u>Part No.</u>	<u>Description</u>
1	939-0032	Gear, 32-Tooth, Fuser Assembly
2	939-0033	Gear/Arm Assembly, Fuser Idler
3	939-0034	Gear, 27-Tooth/18-Tooth, Fuser Assembly
4	959-0033	Bearing, Lower Fuser Assembly Roller
5	984-0005	Roller, Lower Fuser Assembly
6	949-0186	Delivery Sensing Lever
7	948-0035	Static Eliminator
8	949-0240	Paper Fuser Guide
9	948-0034	Cap, Roller, Fuser Assembly
10	957-0038	Spring, Fuser Roller Grounding
11	959-0034	Bearing, Upper Fuser Roller
12	947-0007	Roller, Upper Fuser Assembly
13	939-0035	Gear, 20-Tooth, Fuser Assembly
14	939-0042	Gear, 14-Tooth, Fuser Assembly

Note: The following part shown in this diagram is available as part of the Spring Kit.

A Fuser Spring (5/pk)

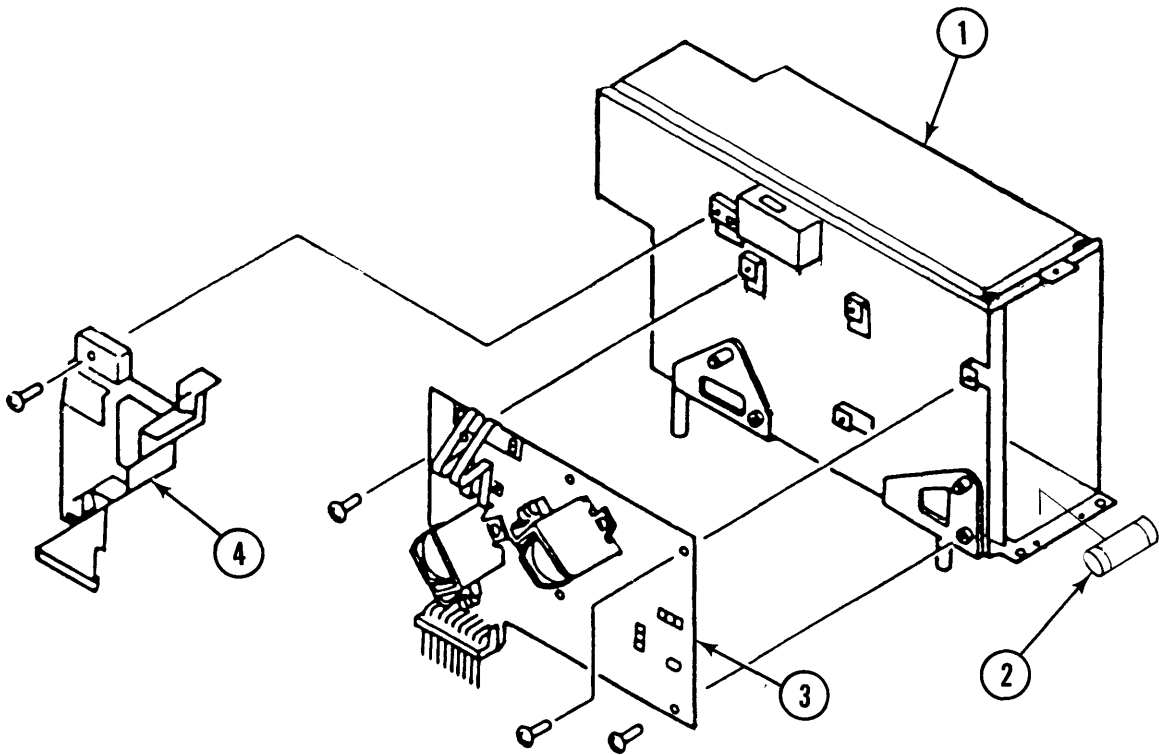

FIGURE 23

□ ELECTRICAL COMPONENTS ASSEMBLY (Figure 23)

<u>Item</u>	<u>Part No.</u>	<u>Description</u>
1	661-0424	DC Power Supply, 110V
	661-0442	DC Power Supply, 220/240V
2	941-0005	Fuse, 125V 6.3
	740-0061	Fuse, Medium Time Lag 3.15A, 250V
3	971-0028	Distribution PCA
4	949-0187	Distribution PCA Cover

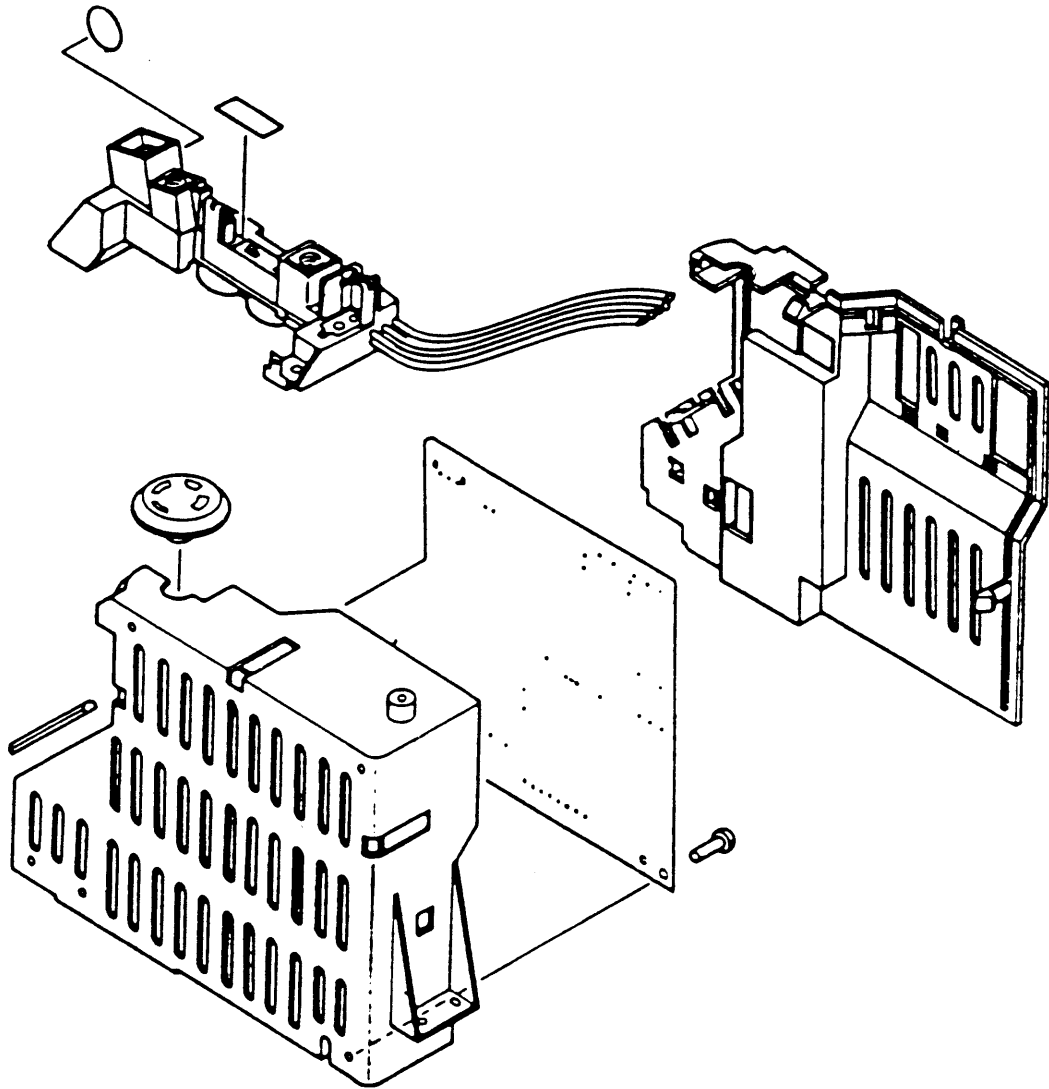

FIGURE 24

□ HIGH-VOLTAGE POWER SUPPLY (Figure 24)

<u>Item</u>	<u>Part No.</u>	<u>Description</u>
-	661-0425	High-Voltage Power Supply

REFURBISHMENT KIT

<u>Part No.</u>	<u>Description</u>
652-0597	Refurbishment Kit

The parts included in this Refurbishment Kit are listed below. Refer to the figures listed to find the illustrations for these parts.

<u>Part No.</u>	<u>Description</u>	<u>See Figure #</u>
661-0440	Fuser Assembly	20
971-0017	Paper Feed Assembly	14
971-0019	Transfer Guide Assembly	16
971-0025	Pre-Cond. Exp. Lamp Assembly	2
971-0026	Transfer Corona Assembly	19

□ SPRING KIT

<u>Part No.</u>	<u>Description</u>
076-0269	Spring Kit

The parts included in the Spring Kit are listed below. Refer to the figures listed to find the illustrations for these parts.

<u>Description</u>	<u>See Figure #</u>
Paper Deflector Spring, (5/pk)	3
Shutter Spring, (5/pk)	12
Left Hook Spring, (5/pk)	13
Right Hook Spring, (5/pk)	13
Right Lifter Spring, (5/pk)	13
Left Lifter Spring, (5/pk)	13
Transfer Guide Spring, (5/pk)	16
Fuser Cam Spring, (5/pk)	21
Fuser Spring, (5/pk)	22

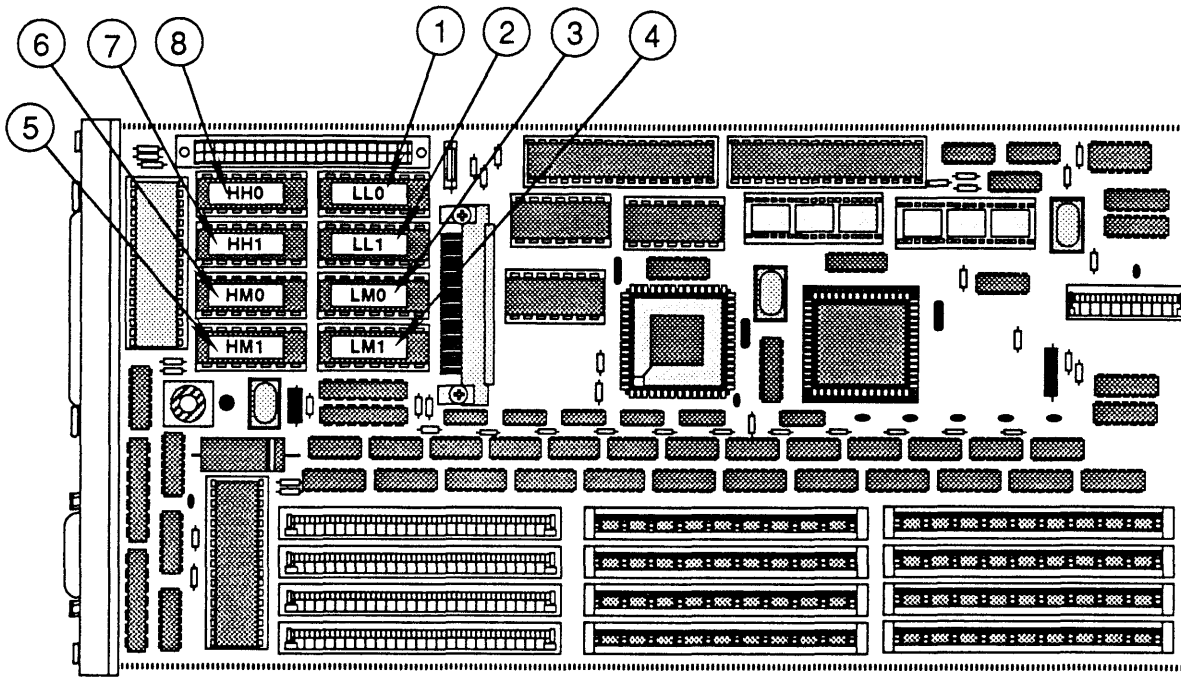

FIGURE 25

□ LW II NTX CONTROLLER-I/O BOARD (Figure 25)

<u>Item</u>	<u>Part No.</u>	<u>Description</u>
–	661-0429	LaserWriter II NTX Controller-I/O Board
1	342-0560	IC, ROM, LL0, LaserWriter II NTX
2	342-0562	IC, ROM, LL1, LaserWriter II NTX
3	342-0564	IC, ROM, LM0, LaserWriter II NTX
4	342-0566	IC, ROM, LM1, LaserWriter II NTX
5	342-0567	IC, ROM, HM1, LaserWriter II NTX
6	342-0565	IC, ROM, HM0, LaserWriter II NTX
7	342-0563	IC, ROM, HH1, LaserWriter II NTX
8	342-0561	IC, ROM, HH0, LaserWriter II NTX

□ LW II NTX CONTROLLER-I/O BOARD (rev. 3) (Figure 25)

<u>Item</u>	<u>Part No.</u>	<u>Description</u>
–	661-1605	LaserWriter II NTX Controller-I/O Board (rev. 3)
1	342-0711	IC, ROM, LL0, LaserWriter II NTX
2	342-0713	IC, ROM, LL1, LaserWriter II NTX
3	342-0715	IC, ROM, LM0, LaserWriter II NTX
4	342-0717	IC, ROM, LM1, LaserWriter II NTX
5	342-0718	IC, ROM, HM1, LaserWriter II NTX
6	342-0716	IC, ROM, HM0, LaserWriter II NTX
7	342-0714	IC, ROM, HH1, LaserWriter II NTX
8	342-0712	IC, ROM, HH0, LaserWriter II NTX

Note: Figure 25 illustrates both the LaserWriter II NTX controller-I/O board and the LaserWriter II NTX controller-I/O board (rev. 3).

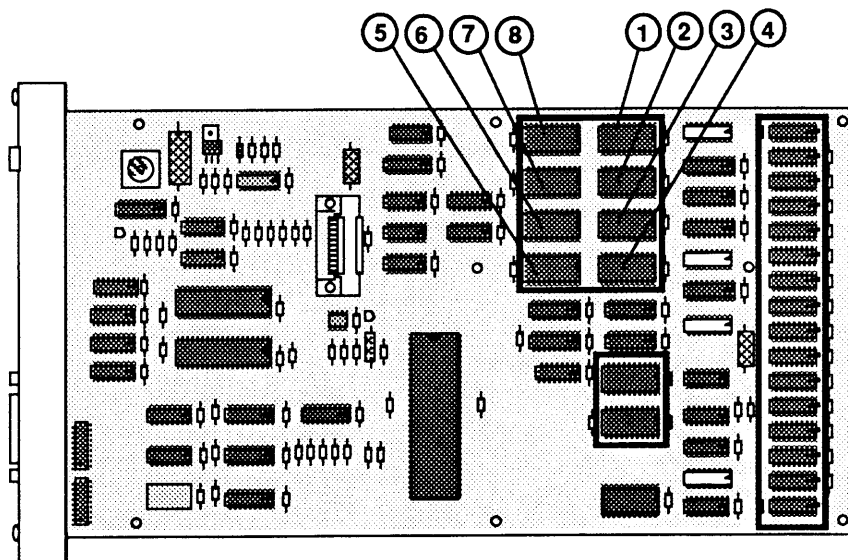

FIGURE 26

□ LW II NT CONTROLLER-I/O BOARD (Figure 26)

<u>Item</u>	<u>Part No.</u>	<u>Description</u>
–	661-0438	LaserWriter II NT Controller-I/O Board
1	342-0546	IC, ROM, H0, LaserWriter II NT
2	342-0548	IC, ROM, H1, LaserWriter II NT
3	342-0550	IC, ROM, H2, LaserWriter II NT
4	342-0552	IC, ROM, H3, LaserWriter II NT
5	342-0551	IC, ROM, L3, LaserWriter II NT
6	342-0549	IC, ROM, L2, LaserWriter II NT
7	342-0547	IC, ROM, L1, LaserWriter II NT
8	342-0545	IC, ROM, L0, LaserWriter II NT

||

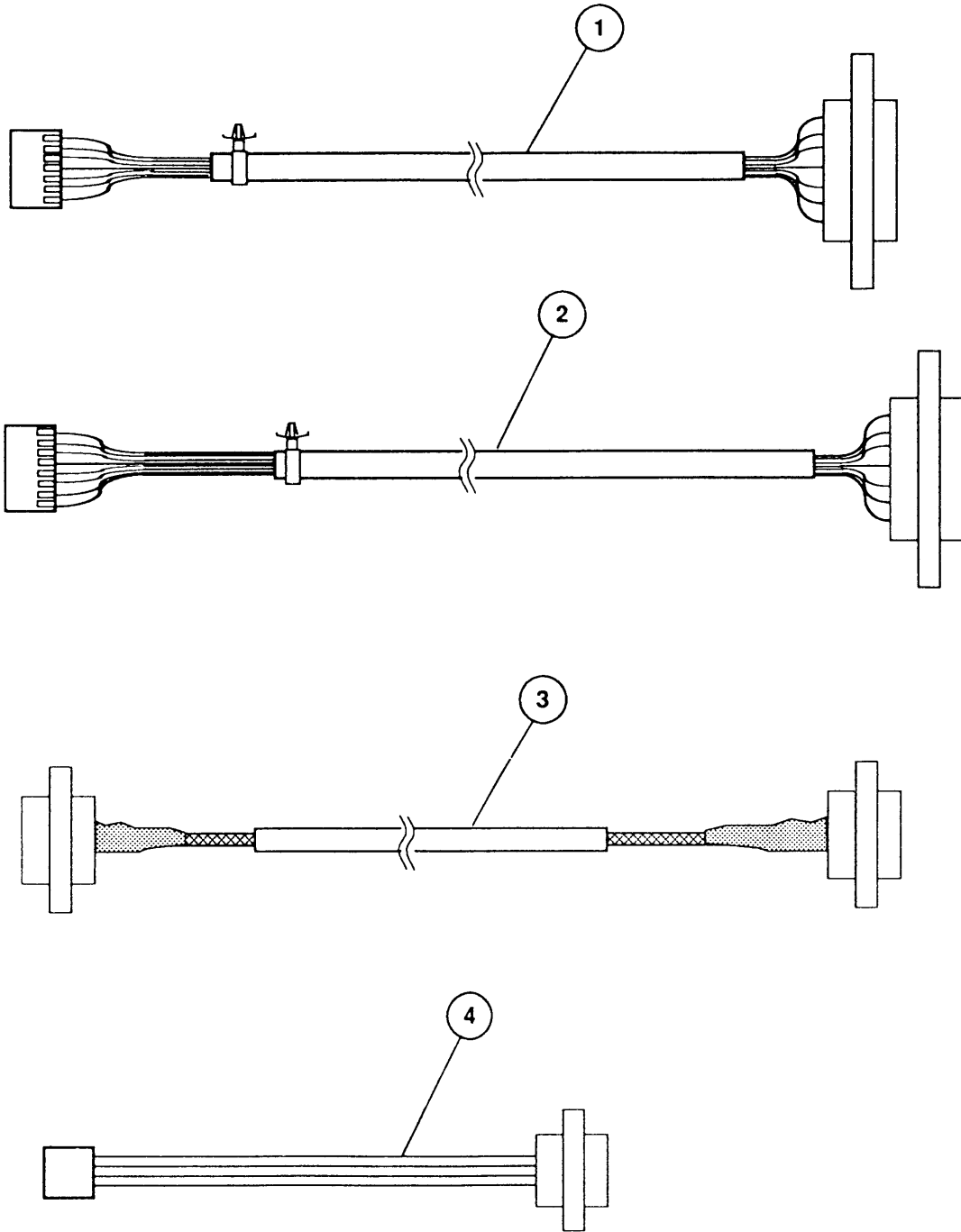

FIGURE 27

□ CABLES (Figure 27)

<u>Item</u>	<u>Part No.</u>	<u>Description</u>
1	936-0103	Cable, DC Controller to Fuser, LaserWriter II
2	936-0101	Cable, DC Controller to High-Voltage Power Supply, LaserWriter II
3	936-0100	Cable, Power Supply Block to DC Power Supply, LaserWriter II
4	936-0102	Cable, DC Controller to Power Supply Block, LaserWriter II

□ SCREW KIT

<u>Part No.</u>	<u>Description</u>
076-0355	Screw Kit

The parts listed below are included in the LaserWriter II Screw Kit. The quantities listed are included in the kit. These parts are not sold separately.

Screw, Binding Head, 3 x 6mm, Nickel (10/pk)
Screw, Binding Head, 4 x 8mm, Nickel (10/pk)
Screw, Binding Head, 3 x 6mm, Black Zinc
(10/pk)
Screw, Washer Head, 3 x 10mm, Nickel (10/pk)
Screw, Washer Head, 3 x 6mm, Black Zinc
(10/pk)
Screw, Washer Head, 3 x 12mm, Black Zinc
(10/pk)
Screw, Washer Head, 3 x 10mm, Black Zinc
(10/pk)
Screw, Self-Tapping, 3 x 6mm, Black Zinc
(10/pk)
Screw, Self-Tapping, 3 x 8mm, Black Zinc
(10/pk)

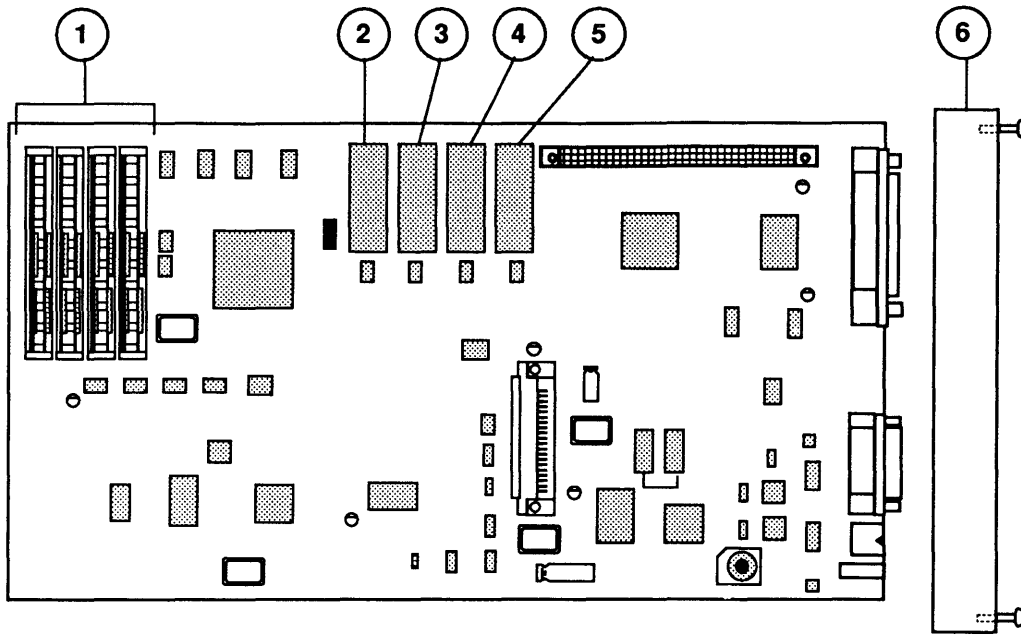

FIGURE 28

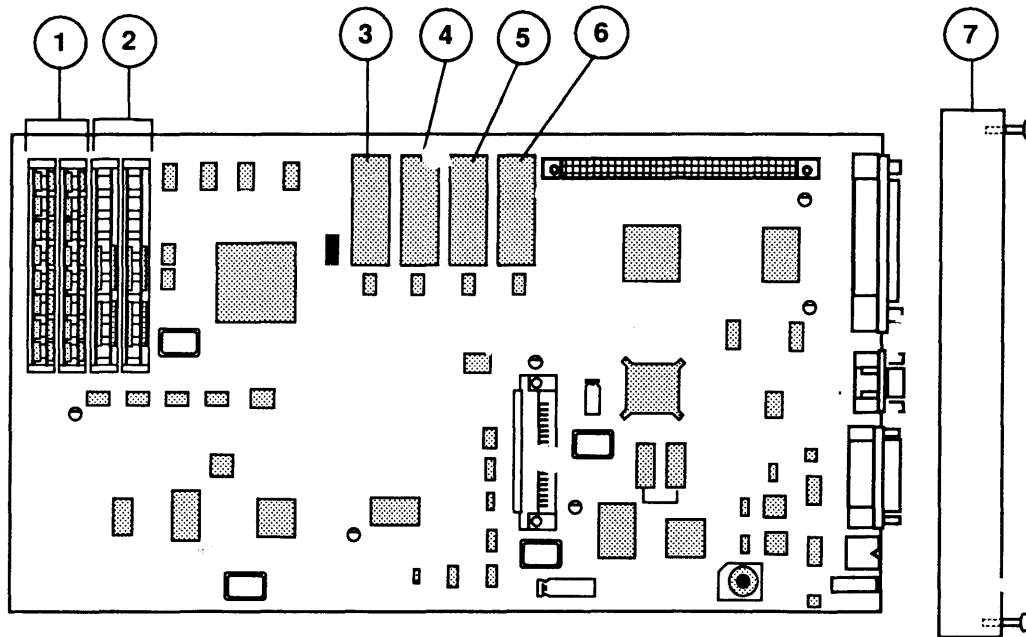

FIGURE 29

□ LASERWRITER IIf CONTROLLER-I/O BOARD (Figure 28)

<u>Item</u>	<u>Part No.</u>	<u>Description</u>
–	661-0770	LaserWriter IIf Controller-I/O Board
1	661-0520	SIMM, 1 MB, 80 ns
	661-0519	SIMM, 256K, 80 ns
2	076-0863	IC, ROM, UU (341-0863), LaserWriter IIf and IIfg
3	076-0862	IC, ROM, UM (341-0862), LaserWriter IIf and IIfg
4	076-0861	IC, ROM, LM (341-0861), LaserWriter IIf and IIfg
5	076-0860	IC, ROM, LL (341-0860), LaserWriter IIf and IIfg
6	076-0418	Assy, LaserWriter IIf Controller-I/O Board Bracket

□ LASERWRITER IIfg CONTROLLER-I/O BOARD (Figure 29)

<u>Item</u>	<u>Part No.</u>	<u>Description</u>
–	661-0769	LaserWriter IIfg Controller-I/O Board
1	661-0520	SIMM, 1 MB, 80 ns
2	661-0519	SIMM, 256K, 80 ns
3	076-0863	IC, ROM, UU (341-0863), LaserWriter IIf and IIfg
4	076-0862	IC, ROM, UM (341-0862), LaserWriter IIf and IIfg
5	076-0861	IC, ROM, LM (341-0861), LaserWriter IIf and IIfg
6	076-0860	IC, ROM, LL (341-0860), LaserWriter IIf and IIfg
7	076-0417	Assy, LaserWriter IIfg Controller-I/O Board Bracket

