

OPERATING AND SERVICE MANUAL

# 7970B/7970C

## DIGITAL MAGNETIC TAPE UNITS

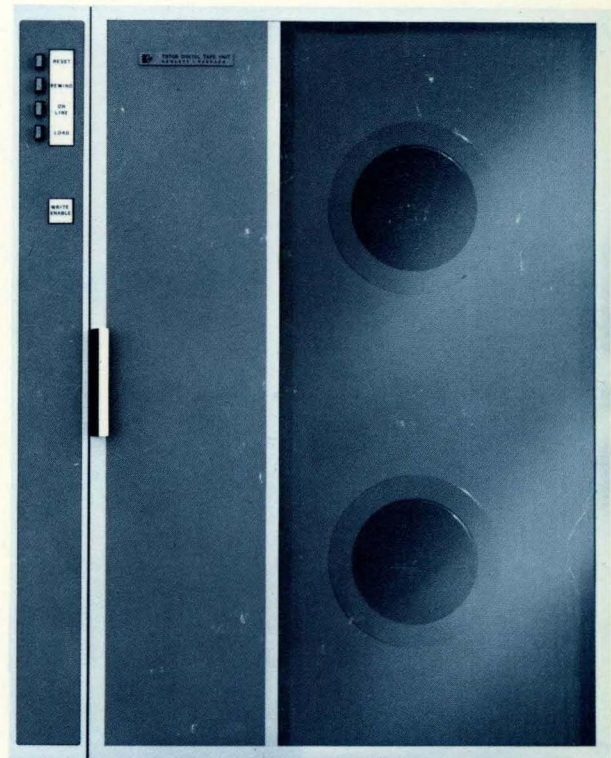

HEWLETT  PACKARD

## OPERATING AND SERVICE MANUAL

# 7970B/7970C

### DIGITAL MAGNETIC TAPE UNITS

#### Serial Numbers Covered

This manual applies directly to HP 7970B/7970C Digital Magnetic Tape Units having serial numbers prefixed 1329. Units with higher serial number prefixes will be covered by updating supplements. Units with serial numbers prefixed 1323 and below are covered by a backdating appendix located at the back of this manual.

#### Options Covered

This manual covers options 006, 007, 012, 013, 014, 015, 016, 017, and 023 as well as the standard HP 7970B/7970C Digital Magnetic Tape Units.



# CONTENTS

## PART 1 — OPERATION AND GENERAL INFORMATION

Section	Page	Section	Page
<b>I DESCRIPTION</b>		3-8. Selection and Care of Tape . . . . .	3-1
1-1. Manual Scope . . . . .	1-1	3-9. Tape Selection . . . . .	3-1
1-4. Identification . . . . .	1-1	3-11. Care of Magnetic Tape . . . . .	3-1
1-9. Description . . . . .	1-2	3-13. Tape Storage . . . . .	3-1
1-11. Transport . . . . .	1-2	3-15. Installation/Removal of Write Enable Ring . . . . .	3-1
1-13. Tape Unit Housing . . . . .	1-2	3-17. Installation of BOT and EOT Photosense Tabs . . . . .	3-1
1-15. Head Assembly . . . . .	1-2	3-19. Tape Reel Installation . . . . .	3-1
1-19. Write Enable Assembly . . . . .	1-2	3-21. Tape Threading Procedure . . . . .	3-6
1-21. Density Select . . . . .	1-2	3-23. Operation . . . . .	3-6
1-23. Unit Address Select . . . . .	1-2	3-25. On-Line Read-Only Operation . . . . .	3-6
1-25. Specifications . . . . .	1-2	3-27. On-Line Write-Read Operation . . . . .	3-6
1-27. Options . . . . .	1-2	3-29. Rewind . . . . .	3-6
1-29. Accessories Furnished . . . . .	1-5	3-31. Restart after Power Failure . . . . .	3-6
1-31. Accessories Available . . . . .	1-5	3-33. REV, FWD, and +160 Capstan Servo Toggle Switches . . . . .	3-8
<b>II INSTALLATION</b>		3-35. Checkout Procedures . . . . .	3-8
2-1. Introduction . . . . .	2-1	3-37. Off-Line Performance Checks . . . . .	3-8
2-3. Unpacking and Inspection . . . . .	2-1	3-39. Mechanical Check . . . . .	3-8
2-6. Site Selection . . . . .	2-1	3-41. Motion Control Checkout Procedure . . . . .	3-8
2-8. Installation . . . . .	2-1	3-43. On-Line Performance Checks . . . . .	3-9
2-10. Cables and Connectors . . . . .	2-2	3-45. Transport Performance Checks (Simulated On-Line) . . . . .	3-10
2-14. Multiple Unit Installation . . . . .	2-2	3-47. Read Data Performance Check (Simulated On-Line) . . . . .	3-10
2-17. Input/Output Line Transmitters and Receivers . . . . .	2-2	3-49. Write Data Performance Check (Simulated On-Line) . . . . .	3-11
2-19. Waveform and Event Timing . . . . .	2-2	3-51. Operator Maintenance . . . . .	3-11
2-21. Checkout Procedures . . . . .	2-2	3-56. Fuse Replacement . . . . .	3-13
2-23. Reshipment . . . . .	2-2	3-57. AC Line Fuses . . . . .	3-13
<b>III OPERATION</b>		3-59. Secondary Voltage Fuses . . . . .	3-13
3-1. Introduction . . . . .	3-1		
3-6. Operating Controls and Indicators . . . . .	3-1		

## PART 2 — TAPE TRANSPORT

Section	Page	Section	Page
<b>I DESCRIPTION</b>		<b>II THEORY OF OPERATION</b>	
1-1. Introduction . . . . .	1-1	2-1. Introduction . . . . .	2-1
1-3. Physical Description . . . . .	1-1	2-3. Overall Functional Description . . . . .	2-1
1-6. Speed Critical Assemblies . . . . .	1-1	2-11. Circuit Descriptions . . . . .	2-1
1-8. Reel Motors . . . . .	1-1	2-13. Power Supply and Power Distribution Circuits . . . . .	2-1
1-10. Capstan Motor Assembly . . . . .	1-1	2-18. Power Regulator Circuits . . . . .	2-2
1-12. Capstan Servo Printed-Circuit Assembly . . . . .	1-1	2-23. Control and Status Circuits . . . . .	2-3
1-14. Magnetic Tape Head Assembly . . . . .	1-1	2-36. Capstan Servo Circuits . . . . .	2-7
1-16. Read Modules . . . . .	1-1	2-50. Reel Servo Circuits . . . . .	2-8
1-18. Write Modules . . . . .	1-1		
1-20. Basic and Optional Assemblies . . . . .	1-2		

## CONTENTS (Continued)

### PART 2 — TAPE TRANSPORT (Continued)

Section	Page	Section	Page
<b>III PERFORMANCE CHECKOUT</b>		5-6. Mechanical Adjustments . . . . .	5-1
3-1. Introduction . . . . .	3-1	5-8. Tape Roller . . . . .	5-1
3-3. Test Equipment Required . . . . .	3-1	5-11. Tension Arm . . . . .	5-1
3-7. Checkout Procedures . . . . .	3-1	5-15. Write Enable Switch . . . . .	5-2
3-9. Preliminary Power-Off Checks . . . . .	3-1	5-17. Reel Retaining Knob . . . . .	5-2
3-11. Operator Control Checks . . . . .	3-2	5-19. Electrical Adjustments . . . . .	5-3
3-17. Service Switches and Accessory Checks . . . . .	3-2	5-21. Power Supply Adjustments . . . . .	5-3
3-20. Tape Path Evaluation . . . . .	3-2	5-23. Capstan Motor Offset Current Adjustment . . . . .	5-4
3-22. Power Supply Voltage Checks . . . . .	3-2	5-27. Capstan Servo Forward and Reverse Drive Speed Adjustments . . . . .	5-4
3-26. Tape Speed and Capstan Servo Checks . . . . .	3-3	5-30. Capstan Servo High-Speed Forward Adjustment . . . . .	5-5
3-29. Transport Function, Motion, and Status Checks . . . . .	3-5	5-32. Capstan Servo High-Speed Reverse Adjustment . . . . .	5-5
<b>IV REPAIR AND REPLACEMENT</b>		5-34. Capstan Servo Ramp Slope Adjustment . . . . .	5-5
4-1. Introduction . . . . .	4-1	5-36. Reel Servo Adjustments . . . . .	5-6
4-3. Repair . . . . .	4-1		
4-6. Replacement . . . . .	4-2	<b>VI REPLACEABLE PARTS</b>	
4-8. Tape Roller and Bearing Assembly . . . . .	4-2	6-1. Introduction . . . . .	6-1
4-10. Capstan (10 - 37.5 ips Units Only) . . . . .	4-2	6-4. Assembly Parts List . . . . .	6-1
4-12. Capstan (37.6 - 45 ips Units Only) . . . . .	4-2	6-6. Figure and Index Number . . . . .	6-1
4-14. Reel Holddown Assembly . . . . .	4-2	6-8. Part Number . . . . .	6-1
4-16. Tension Arm Assembly . . . . .	4-2	6-10. Description . . . . .	6-1
4-18. Photosense Assembly . . . . .	4-3	6-13. Units Per Assembly . . . . .	6-1
4-20. Magnetic Head Assembly . . . . .	4-3	6-15. Ordering Information . . . . .	6-1
4-22. Reel Servo Printed-Circuit Assembly . . . . .	4-3	6-17. Part Number Cross Reference . . . . .	6-1
4-24. Capstan Servo Printed-Circuit Assembly . . . . .	4-3		
<b>V ADJUSTMENT PROCEDURES</b>		<b>VII MAINTENANCE DIAGRAMS</b>	
5-1. Introduction . . . . .	5-1		
5-3. Test Equipment Required . . . . .	5-1		

### PART 3 — READ MODULES

Section	Page	Section	Page
<b>I DESCRIPTION</b>		2-5. Performance Test Procedures . . . . .	2-1
1-1. Introduction . . . . .	1-1	2-7. Read Preamplifier Gain Test . . . . .	2-1
1-3. Physical Description . . . . .	1-1	2-9. Read Threshold Level Test. . . . .	2-1
1-8. Functional Description . . . . .	1-1	2-11. Read Head Static Skew Test . . . . .	2-1
1-12. Circuit Description . . . . .	1-1	2-13. Compensated Static Read Skew Test . . . . .	2-2
1-15. Read Control Circuits . . . . .	1-1	2-15. Read Character Gate, Strobe, and Read Clock Test . . . . .	2-3
1-24. Read Data Circuits . . . . .	1-2	2-18. Adjustment Procedures . . . . .	2-3
<b>II MAINTENANCE</b>		2-20. Preamplifier Gain Adjustments . . . . .	2-3
2-1. Introduction . . . . .	2-1	2-22. Forward Static Skew Compensation Adjustments . . . . .	2-4
2-3. Test Equipment Required . . . . .	2-1		

**CONTENTS (Continued)****PART 3 — READ MODULES (Continued)**

Section	Page	Section	Page
2-24. Reverse Static Skew Compensation Adjustments . . . . .	2-4	3-8. Part Number . . . . .	3-1
2-27. Read Character Gate Adjustments . . . . .	2-4	3-10. Description . . . . .	3-1
<b>III REPLACEABLE PARTS</b>		3-13. Units Per Assembly . . . . .	3-1
3-1. Introduction . . . . .	3-1	3-15. Ordering Information . . . . .	3-1
3-4. Assembly Parts Lists . . . . .	3-1	3-17. Part Number Cross Reference . . . . .	3-1
3-6. Figure and Index Number . . . . .	3-1	<b>IV MAINTENANCE DIAGRAMS</b>	

**PART 4 — WRITE MODULES**

Section	Page	Section	Page
<b>I DESCRIPTION</b>		2-19. Write Crosstalk Test . . . . .	2-3
1-1. Introduction . . . . .	1-1	2-21. Internal Write Clock Delay and Pulse Width Test . . . . .	2-3
1-3. Physical Description . . . . .	1-1	2-23. Data Transfer Characteristics Test . . . . .	2-3
1-8. Functional Description . . . . .	1-1	2-29. Adjustment Procedures . . . . .	2-4
1-13. Circuit Description . . . . .	1-1	<b>III REPLACEABLE PARTS</b>	
1-15. Write Control Circuits . . . . .	1-1	3-1. Introduction . . . . .	3-1
1-25. Write Data Circuits . . . . .	1-3	3-4. Assembly Parts Lists . . . . .	3-1
<b>II MAINTENANCE</b>		3-6. Figure and Index Number . . . . .	3-1
2-1. Introduction . . . . .	2-1	3-8. Part Number . . . . .	3-1
2-3. Test Equipment Required . . . . .	2-1	3-10. Description . . . . .	3-1
2-5. Performance Test Procedures . . . . .	2-1	3-13. Units Per Assembly . . . . .	3-1
2-7. Status and Function Command Test . . . . .	2-1	3-15. Ordering Information . . . . .	3-1
2-11. Write Time Asymmetry Test . . . . .	2-1	3-17. Part Number Cross Reference . . . . .	3-1
2-13. Write/Read Skew Test . . . . .	2-2	<b>IV MAINTENANCE DIAGRAMS</b>	
2-15. Write/Read Phasing and Write Reset Test . . . . .	2-2		
2-17. Erase/Write Phasing Test . . . . .	2-2		

**PART 5 — READ/READ MODULES**

Section	Page	Section	Page
<b>I DESCRIPTION</b>		<b>II MAINTENANCE</b>	
1-1. Introduction . . . . .	1-1	2-1. Introduction . . . . .	2-1
1-3. Physical Description . . . . .	1-1	2-3. Test Equipment Required . . . . .	2-1
1-8. Functional Description . . . . .	1-1	2-5. Performance Test Procedures . . . . .	2-1
1-12. Circuit Description . . . . .	1-1	2-7. Read/Read Pre-amplifier Gain Test . . . . .	2-1
1-14. Read/Read Pre-amplifier . . . . .	1-1	2-9. Read Threshold Level Test . . . . .	2-1
1-17. Read/Read Control Circuits . . . . .	1-2	2-11. Read Head Static Skew Test . . . . .	2-1
1-26. Read Data Circuits . . . . .	1-3	2-13. Compensated Static Read Skew Test . . . . .	2-2

## CONTENTS (Continued)

### PART 5 — READ/READ MODULES (Continued)

Section	Page	Section	Page
2-15. Read Character Gate, Strobe, and Read Clock Test . . . . .	2-2	III REPLACEABLE PARTS	
2-18. Adjustment Procedures . . . . .	2-3	3-1. Introduction . . . . .	3-1
2-20. Preamplifier Gain Adjustments . . . . .	2-3	3-4. Assembly Parts List . . . . .	3-1
2-22. Nine-Track Static Skew Compensation Adjustments . . . . .	2-3	3-6. Figure and Index Number . . . . .	3-1
2-24. Seven-Track Static Skew Compensation Adjustments . . . . .	2-5	3-8. Part Number . . . . .	3-1
2-27. Read Character Gate Adjustments . . . . .	2-5	3-10. Description . . . . .	3-1
		3-13. Units Per Assembly . . . . .	3-1
		3-15. Ordering Information . . . . .	3-1
		3-17. Part Number Cross Reference . . . . .	3-1
		IV MAINTENANCE DIAGRAMS	

### APPENDIX A — BACKDATING INFORMATION

## ILLUSTRATIONS

### PART 1 — OPERATION AND GENERAL INFORMATION

Figure	Title	Page	Figure	Title	Page
1-1.	Hewlett-Packard 7970B/7970C Digital Magnetic Tape Units . . . . .	1-0	2-3.	Multiple Unit Installation . . . . .	2-10
1-2.	Tape Unit Assemblies, Main Casting (Rear View) . . . . .	1-3	2-4.	Electrical Parameters of the I/O Line Transmitters and Receivers . . . . .	2-11
1-3.	Tape Unit Housing Assemblies . . . . .	1-4	2-5.	Write Waveforms . . . . .	2-11
1-4.	Magnetic Tape Head Assembly . . . . .	1-5	2-6.	Read Waveforms . . . . .	2-12
2-1.	Tape Unit Interface Connectors . . . . .	2-3	3-1.	Tape Unit Controls and Indicators . . . . .	3-2
2-2.	Interconnection Cable Fabrication . . . . .	2-9	3-2.	Installation of Photosense Tabs . . . . .	3-5
			3-3.	Tape Threading . . . . .	3-7

### PART 2 — TAPE TRANSPORT

Figure	Title	Page	Figure	Title	Page
2-1.	Tape Transport Functional Block Diagram . . . . .	2-2	5-1.	Tape Roller and Bearing Assembly, Exploded View . . . . .	5-2
2-2.	Power Supply Voltage Regulators, Simplified Diagram . . . . .	2-3	5-2.	Write Enable Assembly . . . . .	5-3
2-3.	Load Function, Simplified Diagram . . . . .	2-5	5-3.	Capstan Servo PC Assembly, Test Points and Adjustments . . . . .	5-4
2-4.	Capstan Servo, Block Diagram . . . . .	2-7	5-4.	Start/Stop Ramp Time . . . . .	5-5
2-5.	Reel Servo, Block Diagram . . . . .	2-9	6-1.	7970B/7970C Digital Magnetic Tape Unit. . . . .	6-2
4-1.	Capstan Position . . . . .	4-2			

## ILLUSTRATIONS (Continued)

### PART 2 — TAPE TRANSPORT (Continued)

Figure	Title	Page	Figure	Title	Page
6-2.	Tape Roller and Bearing Assembly . . . . .	6-9	7-2.	Power Supply and Distribution Assemblies A19, A20, and A21, Schematic Diagrams . . . . .	7-3
6-3.	Capstan Motor Assembly MG1, 10 - 37.5 ips . . . . .	6-10	7-3.	Unit Address Switch Assembly A13, Photosense Assembly A2, and Control Switch Assembly A11, Parts Location Diagrams . . . . .	7-5
6-4.	Capstan Motor Assembly MG1, 37.6 - 45 ips . . . . .	6-11	7-4.	Unit Address Switch Assembly A13, Photosense Assembly A2, and Control Switch Assembly A11, Schematic Diagrams . . . . .	7-5
6-5.	Reel Motor Assembly B1/B2 . . . . .	6-13	7-5.	Control and Status PC Assembly A16, Parts Location Diagram . . . . .	7-7
6-6.	Tension Arm Assembly A3/A4 . . . . .	6-14	7-6.	Control and Status PC Assembly A16, Schematic Diagram . . . . .	7-7
6-7.	Control Switch Assembly A11 . . . . .	6-17	7-7.	Reel Servo Assemblies A3/A4 and A7, Parts Location Diagram . . . . .	7-9
6-8.	Photosense Head Assembly A2 . . . . .	6-21	7-8.	Reel Servo Assemblies A3/A4 and A7, Schematic Diagram . . . . .	7-9
6-9.	Magnetic Head Assembly A1 . . . . .	6-22	7-9.	Capstan Servo PC Assembly A6, Parts Location Diagram . . . . .	7-11
6-10.	Unit Address Switch Assembly A13 . . . . .	6-24	7-10.	Capstan Servo PC Assembly A6, Schematic Diagram . . . . .	7-11
6-11.	Transport Harness Assembly W2 . . . . .	6-27	7-11.	Cable Assembly W2, Wiring Diagram . . . . .	7-13
6-12.	Capstan Servo PC Assembly A9 . . . . .	6-32			
6-13.	Reel Servo PC Assembly A7 . . . . .	6-35			
6-14.	Power Regulator PC Assembly A21 . . . . .	6-39			
6-15.	Power Distribution Assembly A20 . . . . .	6-42			
6-16.	Power Distribution PC Assembly . . . . .	6-44			
6-17.	Transformer Assembly A19 . . . . .	6-46			
6-18.	Control and Status PC Assembly A16 . . . . .	6-49			
7-1.	Power Distribution PC Assembly A20 and Power Regulator PC Assembly A21, Parts Location Diagrams . . . . .	7-3			

### PART 3 — READ MODULES

Figure	Title	Page	Figure	Title	Page
1-1.	Read Data Circuits Timing Diagram . . . . .	1-2	4-4.	Read Preamplifier PC Assembly A15, Schematic Diagram . . . . .	4-5
1-2.	Read Control Circuits, Simplified Logic Diagram . . . . .	1-3	4-5.	Read Assembly A18 (Motherboard), Schematic Diagram . . . . .	4-7
1-3.	Read Data Circuit, Simplified Logic Diagram . . . . .	1-3	4-6.	Read Control PC Assembly A18A1, Parts Location Diagram . . . . .	4-9
2-1.	Skew Alignment Waveforms . . . . .	2-5	4-7.	Read Control PC Assembly A18A1, Schematic Diagram . . . . .	4-9
3-1.	Density Select Switch Assembly A12 . . . . .	3-3	4-8.	Single-Channel Read Data PC Assembly (10-20.9 ips) Parts Location Diagram . . . . .	4-11
3-2.	Read Preamplifier PC Assembly A15 . . . . .	3-4	4-9.	Single-Channel Read Data PC Assembly (10-20.9 ips) Schematic Diagram . . . . .	4-11
3-3.	Read Assembly A18 . . . . .	3-6	4-10.	Single-Channel Read Data PC Assembly (21-45 ips) Parts Location Diagram . . . . .	4-13
3-4.	Read Control PC Assembly . . . . .	3-9	4-11.	Single-Channel Read Data PC Assembly (21-45 ips) Schematic Diagram . . . . .	4-13
3-5.	Single-Channel Read Data PC Assembly (10-20.9 ips) . . . . .	3-12	4-12.	Dual-Channel Read Data PC Assembly (10-20.9 ips) Parts Location Diagram . . . . .	4-15
3-6.	Single-Channel Read Data PC Assembly (21-45 ips) . . . . .	3-14	4-13.	Dual-Channel Read Data PC Assembly (10-20.9 ips) Schematic Diagram . . . . .	4-15
3-7.	Dual-Channel Read Data PC Assembly (10-20.9 ips) . . . . .	3-17	4-14.	Dual-Channel Read Data PC Assembly (21-45 ips) Parts Location Diagram . . . . .	4-16
3-8.	Dual-Channel Read Data PC Assembly (21-45 ips) . . . . .	3-21	4-15.	Dual-Channel Read Data PC Assembly (21-45 ips) Schematic Diagram . . . . .	4-17
4-1.	Density Select Switch Assembly A12, Parts Location Diagram . . . . .	4-3			
4-2.	Density Select Switch Assembly A12, Schematic Diagram . . . . .	4-3			
4-3.	Read Preamplifier PC Assembly A15, Parts Location Diagram . . . . .	4-4			



## ILLUSTRATIONS (Continued)

### PART 4 — WRITE MODULES

Figure	Title	Page	Figure	Title	Page
1-1.	Write Control Circuits Block Diagram . . . . .	1-2	4-3.	Write Assembly A17 (Motherboard) and Write Interconnect PC Assembly A14, Schematic Diagram . . . . .	4-5
1-2.	Forward Sampling Pulse Generation. . . . .	1-2	4-4.	Write Control PC Assembly, Parts Location Diagram . . . . .	4-7
1-3.	Write Permit and Clamp Timing Diagram . . . . .	1-3	4-5.	Write Control PC Assembly, Schematic Diagram . . . . .	4-7
1-4.	Typical Write Data Channel, Block Diagram . . . . .	1-4	4-6.	Single-Channel Write Data PC Assembly, Parts Location Diagram . . . . .	4-9
3-1.	Write Enable Assembly A10 . . . . .	3-2	4-7.	Single-Channel Write Data PC Assembly, Schematic Diagram . . . . .	4-9
3-2.	Write Interconnect PC Assembly A14 . . . . .	3-5	4-8.	Dual-Channel Write Data PC Assembly, Parts Location Diagram . . . . .	4-11
3-3.	Write Assembly A17 . . . . .	3-6	4-9.	Dual-Channel Write Data PC Assembly, Schematic Diagram . . . . .	4-11
3-4.	Write Control PC Assembly . . . . .	3-9			
3-5.	Single-Channel Write Data PC Assembly . . . . .	3-12			
3-6.	Dual-Channel Write Data PC Assembly . . . . .	3-14			
4-1.	Write Enable Assembly A10, Schematic Diagram . . . . .	4-3			
4-2.	Write Interconnect PC Assembly A14, Parts Location Diagram . . . . .	4-5			

### PART 5 — READ/READ MODULES

Figure	Title	Page	Figure	Title	Page
1-1.	Typical Read/Read Preamplicifier Circuit, Block Diagram . . . . .	1-1	4-3.	Read/Read Preamplicifier PC Assembly A15, Parts Location Diagram . . . . .	4-5
1-2.	Read Control Circuits, Simplified Block Diagram . . . . .	1-2	4-4.	Read/Read Preamplicifier PC Assembly A15, Schematic Diagram . . . . .	4-5
1-3.	Read Data Circuits, Timing Diagram . . . . .	1-3	4-5.	Read/Read Assembly A18, Schematic Diagram . . . . .	4-7
1-4.	Read Data Circuits, Block Diagram . . . . .	1-4	4-6.	Read/Read Control PC Assembly A18A1, Parts Location Diagram . . . . .	4-9
2-1.	Skew Alignment Waveforms . . . . .	2-4	4-7.	Read/Read Control PC Assembly A18A1, Schematic Diagram . . . . .	4-9
3-1.	Read/Read Density Select Switch Assembly A12 . . . . .	3-2	4-8.	Single-Channel Read Data PC Assembly (10-20.9 ips) Parts Location Diagram . . . . .	4-11
3-2.	Read/Read Preamplicifier PC Assembly A15 . . . . .	3-3	4-9.	Single-Channel Read Data PC Assembly (10-20.9 ips) Schematic Diagram . . . . .	4-11
3-3.	Read/Read Assembly A18 . . . . .	3-6	4-10.	Single-Channel Read Data PC Assembly (21-45 ips) Component Location Diagram. . . . .	4-13
3-4.	Read/Read Control PC Assembly A18A1 . . . . .	3-9	4-11.	Single-Channel Read Data PC Assembly (21-45 ips) Schematic Diagram . . . . .	4-13
3-5.	Single-Channel Read Data PC Assembly (10-20.9 ips) . . . . .	3-12	4-12.	Dual-Channel Read Data PC Assembly (10-20.9 ips) Parts Location Diagram . . . . .	4-14
3-6.	Single-Channel Read Data PC Assembly (21-45 ips) . . . . .	3-14	4-13.	Dual-Channel Read Data PC Assembly (10-20.9 ips) Schematic Diagram . . . . .	4-15
3-7.	Dual-Channel Read Data PC Assembly (10-20.9 ips) . . . . .	3-17	4-14.	Dual-Channel Read Data PC Assembly (21-45 ips) Component Location Diagram. . . . .	4-17
3-8.	Dual-Channel Read Data PC Assembly (21-45 ips) . . . . .	3-21	4-15.	Dual-Channel Read Data PC Assembly (21-45 ips) Schematic Diagram . . . . .	4-17
4-1.	Read/Read Density Select Switch Assembly A12, Parts Location Diagram . . . . .	4-3			
4-2.	Read/Read Density Select Switch Assembly A12, Schematic Diagram . . . . .	4-3			

## TABLES

### PART 1 — OPERATION AND GENERAL INFORMATION

Table	Title	Page	Table	Title	Page
1-1.	Standard Configuration Option Numbers . . .	1-1	2-5.	Detailed Description of I/O Lines, Write Data Connector . . . . .	2-8
1-2.	Elective Option Numbers . . . . .	1-1	2-6.	Detailed Description of I/O Lines, Read Data Connector	
1-3.	Specifications . . . . .	1-6	3-1.	Tape Unit Controls and Indicators . . . . .	3-3
2-1.	Control and Status Connector . . . . .	2-3	3-2.	Operator Preventive Maintenance Schedule . . .	3-12
2-2.	Write Data Connector . . . . .	2-4	3-3.	Service Preventive Maintenance Schedule . . .	3-12
2-3.	Read Data Connector . . . . .	2-5	3-4.	Reference Designations and Abbreviations . . .	3-14
2-4.	Detailed Description of I/O Lines, Status, and Motion Control Connector . . . . .	2-6			

### PART 2 — TAPE TRANSPORT

Table	Title	Page
4-1.	Printed-Circuit Assembly Repair Equipment . . .	4-1
5-1.	Capstan Servo Start/Stop Time . . . . .	5-6
6-1.	Part Number Cross Reference . . . . .	6-52

### PART 3 — READ MODULES

Table	Title	Page
3-1.	Part Number Cross Reference . . . . .	3-24

### PART 4 — WRITE MODULES

Table	Title	Page
3-1.	Part Number Cross Reference . . . . .	3-16

### PART 5 — READ/READ MODULES

Table	Title	Page
3-1.	Part Number Cross Reference . . . . .	3-24

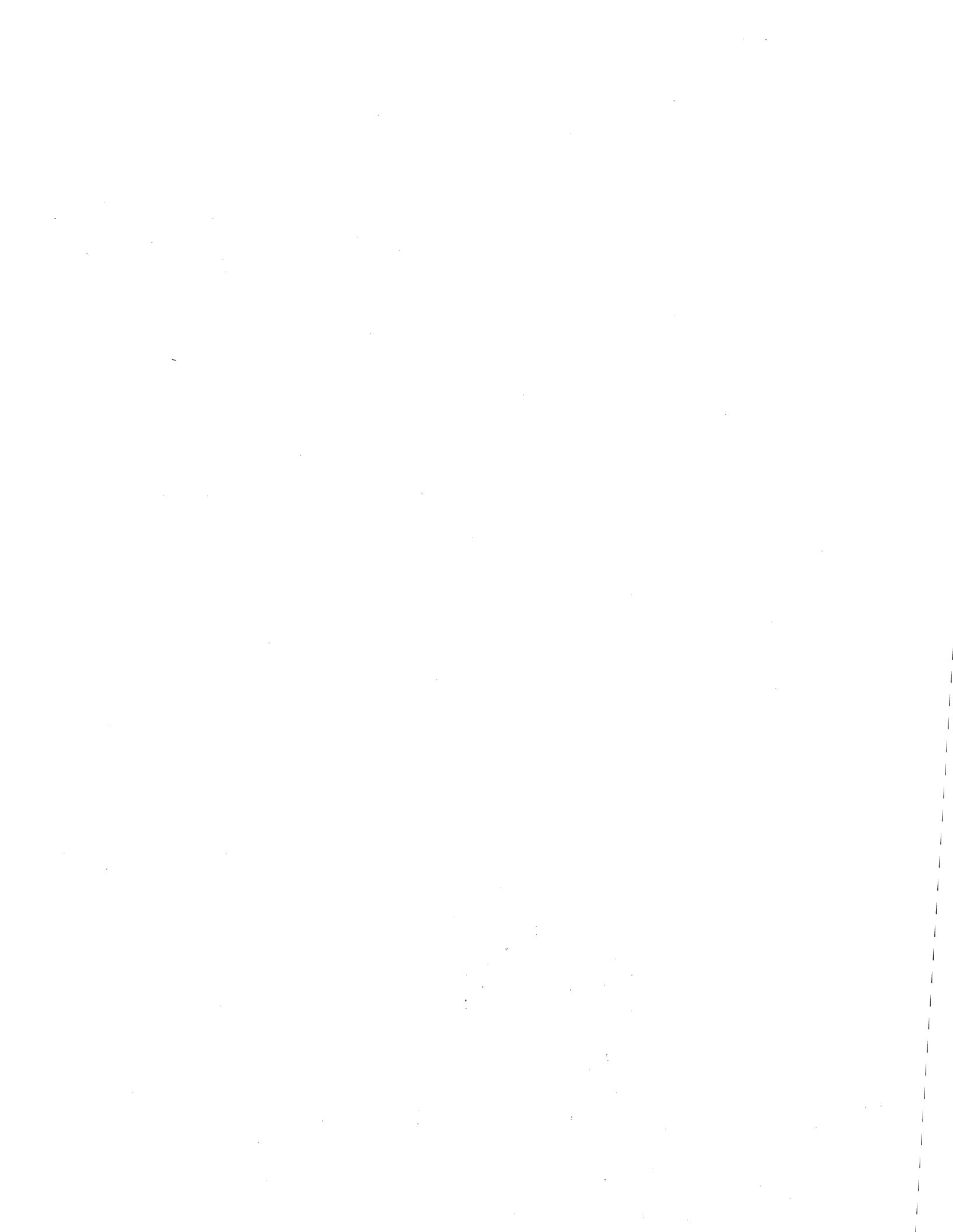

CHANGE TO:

HP 7970B/C Digital Magnetic Tape Unit  
Operating and Service Manual

---

CHANGE DESCRIPTION: This change replaces components on the listed assemblies with more readily available components having the same characteristics.

The following assembly series numbers change:

07970-60240 from 1134 to 1446,  
07970-60530 from 1025 to 1446,  
07970-60570 from 1025 to 1446,  
07970-62004 from 1045 to 1446,  
07970-62005 from 1045 to 1446,  
07970-62170 from 1218 to 1446,  
07970-62171 from 1218 to 1446.

CHANGE INSTRUCTIONS:

- 1 On the parts list tables listed below, note that "for assemblies having series numbers 1446 and above, transistor part number 1854-0270 (2N4265) is replaced by part number 1854-0215 (2N3904). For all series assemblies, either transistor is a suitable field replacement."

*not  
changed*

Part 3, page 3-11, index number 27.  
Part 3, page 3-15, index number 9.  
Part 4, page 3-11, index number 26.  
Part 5, page 3-11, index number 26.  
Part 5, page 3-15, index number 9.  
Part 5, page 3-23, index number 25.

- 2 Change the respective schematic diagrams to indicate coverage of series 1446 assemblies in addition to the current series.

CHANGE TO:

HP 7970B/C Digital Magnetic Tape Units  
Operating and Service Manual

---

CHANGE DESCRIPTION: This change allows use of the 07970-62062 Control and Status PCA in 7970B/C units. This PCA is fully compatible with the previous 07970-61080 Control and Status PCA.

The Magnetic Tape Unit serial number prefix changes from 1443 to 1514.

CHANGE INSTRUCTIONS:

- 1 Replace page 7-7, part 2 with the page provided by this change notice.
- 2 On page 6-51, part 2. Note that the parts breakdown applies to both 07970-61080 and 07970-62062 PCA's.
- 3 Add assembly 07970-62062 series 1348 to the list of printed-circuit assemblies on the title page for part 2.

*not  
changed*



### CHANGE TO:

HP 7970B/C Digital Magnetic Tape Units  
Operating and Service Manual

**CHANGE DESCRIPTION:** Under certain conditions the Write Enable circuitry can fail and still provide an active WRITE STATUS signal to the controller. This change to the Write Control PCA corrects this problem.

The following assembly series number changes:

07970-60240 from 1446 to 1510.

The Tape Unit serial number prefix changes from 1443 to 1524.

### CHANGE INSTRUCTIONS:

1 Part 4, page 4-7, figure 4-5. Change the logic diagram as shown below. Change the series code from 1446 to 1510.

2 Part 4, page 4-7, figure 4-4. On the parts location diagram add reference designator R35 between R5 and R12. Add R34 just above R4. Add Q7 between R34 and R15. Change the PCA series code to 1510.

3 Part 4, page 3-11. Add the following items to the parts list:

33	0683-4725	RESISTOR, fxd, 4.7K, 5%, 1/2W, (R34)	1
34	0683-6225	RESISTOR, fxd, 6.2K, 5%, 1/2W, (R35)	1
35	1854-0215	TRANSISTOR (Q7)	1

4 Part 4, page 3-9 and 3-10, figure 3-4. Add parts and index numbers as shown on the back of this supplement.

*not changed*

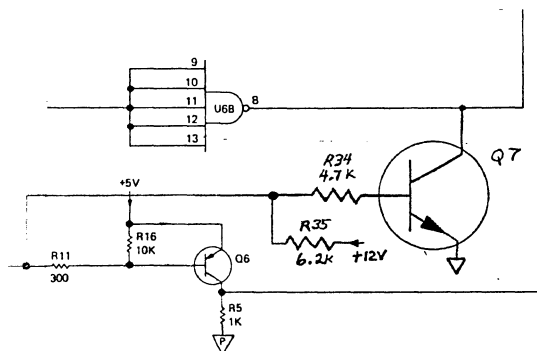

Change 3  
MAY 1975

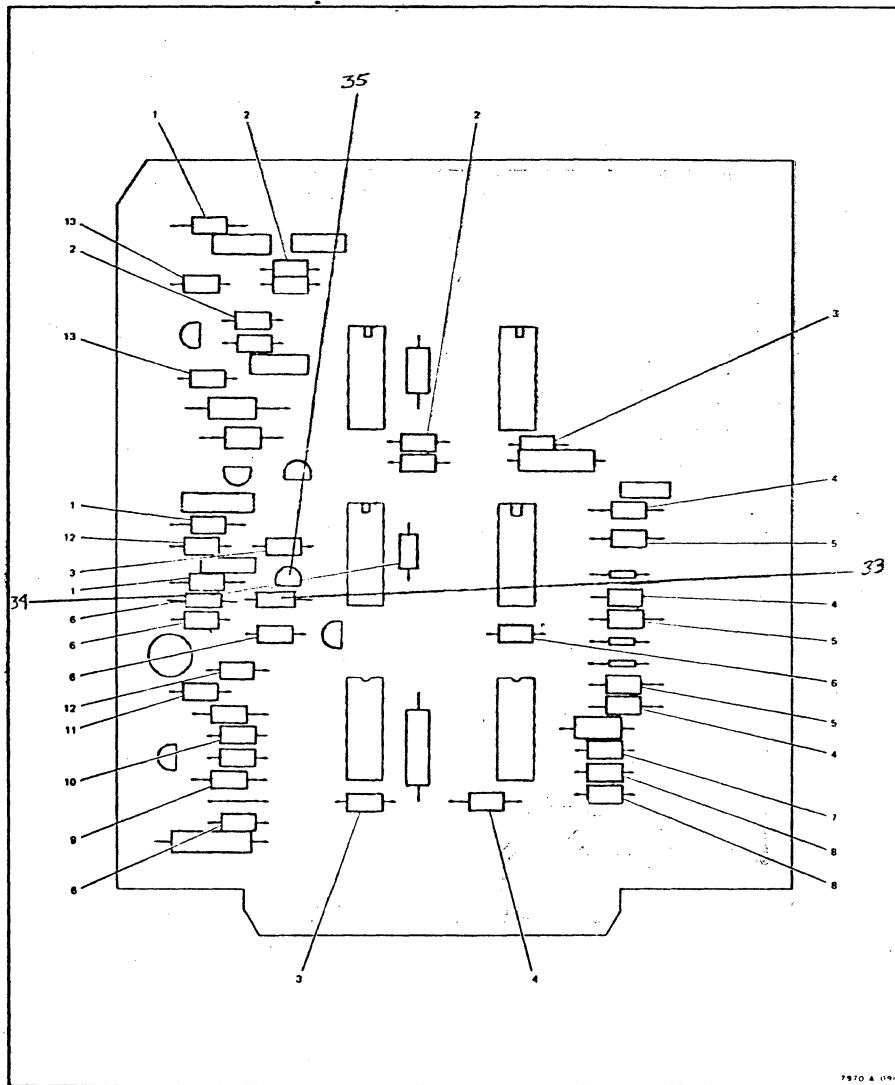

CHANGE TO:

HP 7970B/C Digital Magnetic Tape Units  
Operating and Service Manual

---

CHANGE DESCRIPTION:

Effective 1 AUG, 1975, the configurations and options of the HP 7970 Digital Magnetic Tape Units have changed. Units ordered using the previous configurations will be identified as they were ordered and the configuration information given in Section I of the manual will still apply.

The following information describes the new system of configurations and options and should be used to replace the corresponding information in Section I for units ordered under the new system.

There are two standared configurations of 7970B Digital Magnetic Tape Units as follows:

7970B-127 45ips, 800cpi, 9-track, read after write.

7970B-136 45ips, 200/556/800cpi, 7-track, read after write

Elective options are as follows:

- 001 Changes speed to 37.5 ips.
- 002 Changes speed to 25.0 ips.
- 004 Adds service extender boards.
- 005 Adds 3 I/O connectors.
- 007 Adds unit select switch.
- 011 Deletes HP logo.

*Not  
Changed*





CHANGE TO:

HP 7970B/C Digital Magnetic Tape Unit  
Operating and Service Manual

---

**CHANGE DESCRIPTION:** This change to the manual reflects a component change made on the 07970-62000 Read Preamplifier printed circuit assembly.

The following assembly series code changes:

07970-62000 from 1201 to 1536

The Tape Unit serial number prefix changes from 1524 to 1536

**CHANGE INSTRUCTIONS:**

- 1 Part 3, title page. Change series of 07970-62000 PCA from 1201 to 1536.
- 2 Part 3, page 3-5. Change the part number for index number 12 from 1826-0044 to 1826-0318.
- 3 Part 3, page 4-5/4-6, figure 4-4. In the upper-left corner of the schematic, change the entry for 07970-62000 to read, "07970-62000, SERIES 1201, 1536".

*Not  
changed*

CHANGE TO:

HP 7970B/C Digital Magnetic Tape Unit  
Operating and Service Manual

**CHANGE DESCRIPTION:** This change to the manual reflects the addition of components to eliminate noise spikes generated on the WRITE CLOCK line when the 07970-60240 write control PCA is used with certain interfaces.

The following assembly series number changes:

07970-60240 from 1510 to 1606

The Tape Unit serial number prefix changes from 1536 to 1606

**CHANGE INSTRUCTIONS:**

- 1 Part 4, title page. Change series of 07970-60240 PCA to 1606.
- 2 Part 4, page 3-11. Add the following entry:  
36 1901-0539 DIODE, Schottky (CR10, CR11, CR12) 3
- 3 Part 4, page 3-9 and 3-10, figure 3-4. Add parts and index numbers (#36) as shown in figure 1.
- 4 Part 4, page 4-7, figure 4-5. Add diodes CR10, CR11, and CR12 as indicated in figure 2 of this change notice. Add series 1606 to the title block of this schematic.
- 5 Part 4, page 4-7, figure 4-4. Add diodes CR10, CR11, and CR12 to the parts location diagram as shown in figure 3 of this change notice.

*not changed*

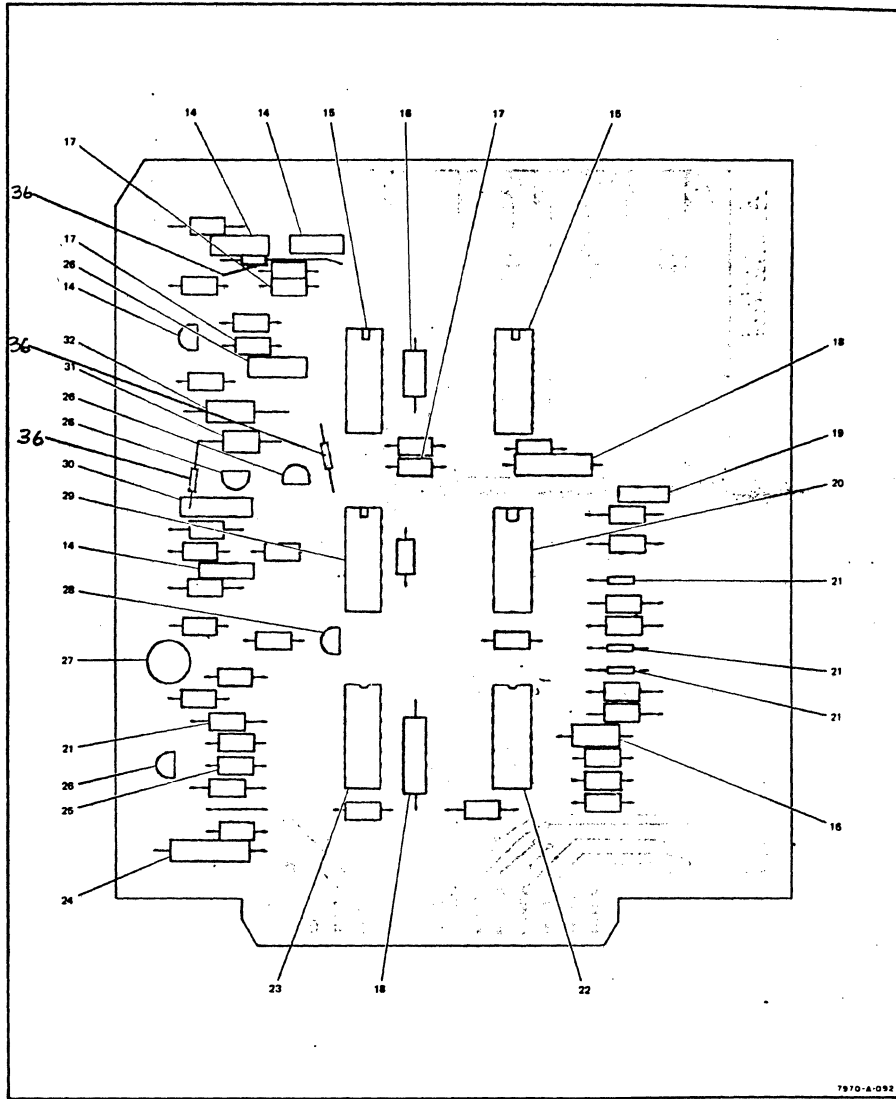

Figure 1.

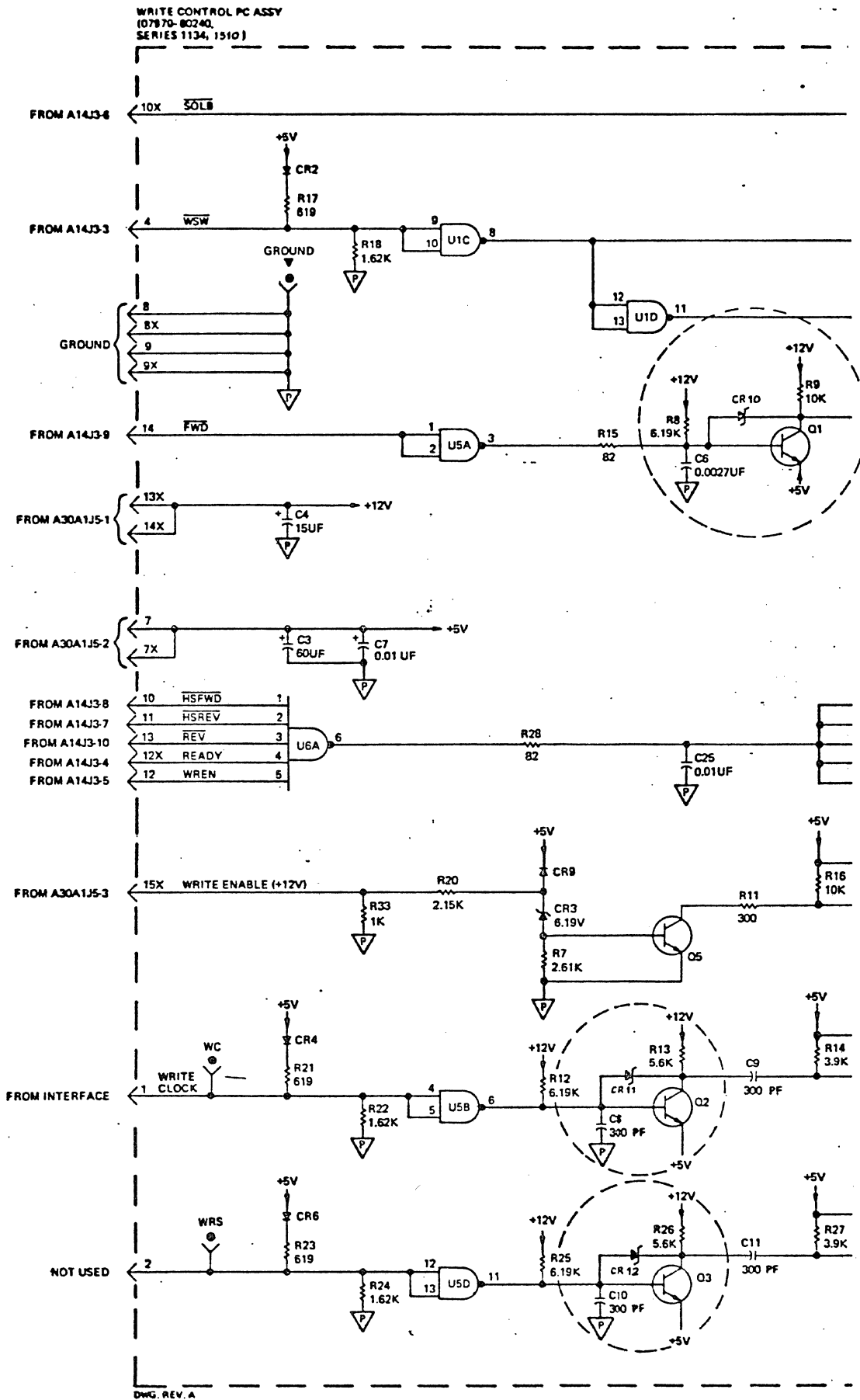

Figure 2.



CHANGE TO:

HP 7970B/C Digital Magnetic Tape Unit  
Operating and Service Manual

**CHANGE DESCRIPTION:** This change to the manual reflects a component change made on the 07970-62000 Read Preamplifier printed-circuit assembly.

The following assembly series number changes:

07970-62000 from 1536 to 1607

The Tape Unit serial number prefix changes from 1606 to 1607

CHANGE INSTRUCTIONS

- 1 Part 3, title page. Change series of 07970-62000 PCA from 1536 to 1607.
  - 2 Part 3, page 3-5. Add the following entry below item 13.
- |    |           |   |   |
|----|-----------|---|---|
| 13 | 2100-3352 | RESISTOR, var, 500 ohms, 1/2W (R3,R7,R11,R15, R19,R23,R27,R31,R35) (used in 07970-62000, SERIES 1607) | 9 |
|----|-----------|---|---|
- 3 Part 3, page 4-5, figure 4-4. In the schematic title block, change the entry for 07970-62000 to read, "07970-62000, SERIES 1201,1536,1607".

*not changed*

# UPDATING SUPPLEMENT

1 NOV 1974

**MANUAL IDENTIFICATION**

 Manual Serial No. Prefix: 1329  
 Manual Printed: AUG 1973  
 Manual Part No.: 07970-90383  
 Microfiche Part No.: 07970-90820

**SUPPLEMENT DESCRIPTION**

The purpose of this supplement is to adapt the manual to equipment containing production improvements made subsequent to the printing of the manual and to correct manual errors. Enter the new information (or the Change Number, if more convenient) into the appropriate places in the manual, identified at left. For any given instrument serial number prefix, all change steps noted for prior serial number prefixes must be incorporated in addition to those for the given prefix.

MANUAL ERRATA CHANGES: 1 thru 8, 9 thru 15, 20 thru 22, 27 thru 34, 41 thru 47, 54, 55, 60, 66 thru 70, 75				
ASSEMBLY AND INSTRUMENT CHANGES:				
ASSEMBLY PART NO.	DESCRIPTION	SERIES	SERIAL PREFIX	CHANGES
07970-60471	Transformer Assembly	1343	1343	16
07970-61010	Power Regulator PCA	1344	1344	17 thru 19
07970-61080	Control and Status PCA	1348	1348	23 thru 26
07970-62297	Read Preamp PCA	1350	1350*	35 thru 40
07970-60500	Read Preamp PCA	1350	1350*	35 thru 40
07970-62087	Density Select PCA	1330	NC	48 thru 50
07970-62088	Density Select PCA	1330	NC	51 thru 53
07970-61080	Control and Status PCA	1348	1408	23 thru 26
07970-62172	Capstan Servo PCA	1410	1410	56 thru 59
07970-60471	Transformer Assembly	1411	1411	61 thru 65
07970-61150	Photosense Head Assembly	1426	1426	76 thru 78
07970-62200 thru 07970-62204 07970-62206 thru 07970-62208 07970-62211 07970-62199	Head Assembly	1432	NC	71 and 72
07970-62089	Control Switch Assembly	NC	NC	73 and 74
07970-62299	Read/Read Density Select Switch	1350	NC	79 thru 82
07970-62035	Read Preamplifier PCA	1439	1439	83 and 84
* Instrument serial prefix 1350 applies to low speed units only.				

ASSEMBLY PART NO.	DESCRIPTION	SERIES	SERIAL PREFIX	CHANGES
07970-60471	Transformer Assy	1443	1443	85,86



CHANGEDESCRIPTION

- 1 Part 5, page 3-5. Delete reference to 07970-62012 PC assembly for 21-45 ips tape units and substitute the 07970-62035 PC assembly parts list attached at the back of this supplement.
- 2 Part 5, page 3-7. Change item 1 part no. from 07970-62003 to 07970-62060.
- 3 Part 5, page 3-11. Delete reference to 07970-62005 PC assembly for 21-45 ips tape units and substitute the 07970-62061 PC assembly parts list attached at the back of this supplement.
- 4 Part 5, page 4-5, figures 4-3 and 4-4. Delete reference to 07970-62012 PCA for 21-45 ips tape units and substitute the 07970-62035 PCA component location and schematic diagrams attached at the back of this supplement.
- 5 Part 5, page 4-7. Replace page 4-7 with page 4-7 attached at the back of this supplement.
- 6 Part 5, page 4-9, figure 4-6 and 4-7. Delete reference to 07970-62005 PCA for 21-45 ips tape units and substitute the 07970-62061 component location and schematic diagrams attached at the back of this supplement.
- ~~7~~ ~~Part 3, page 3-5. Change the description for item 6 (10-209 ips entry) to 4.64K. Change the description for item 6 (21-45 ips entry) to 17.1K. SUPERCEDED~~
- ~~8~~ ~~Part 3, page 4-5, figure 4-4. Change the value of the following resistors to 4.64K: R1, R5, R9, R13, R17, R21, R25, R29, and R33. SUPERCEDED~~
- 9 Part 3, page 2-1, paragraph 2-10. Change threshold level specification for high-speed read mode to 1.0 volt  $\pm$ 1%.
- 10 Part 1, page 1-5, paragraph 1-32. After item c, add the following note:  
The 5080-4525 test tape is applicable for both 7-track and 9-track tape units. Refer to part 2, page 3-3 for test operating instructions.
- 11 Part 3. On pages 3-13, 3-15, 3-19, and 3-23, change the part no. for C12 (and C112) from 0160-3449 to 0160-3457.
- 12 Part 5. On pages 3-13, 3-15, 3-19, and 3-23, change the part no. for C12 (and C112) from 0160-3449 to 0160-3457.
- 13 Part 2, page 6-36, figure 6-13. Add identification for C21 to the right of K1.
- 14 Part 2, page 6-37. Make the following changes to the replaceable parts list.
- a. Delete CR10, Q21, R64, and R107.
  - b. Change R16 and R35 value to 1K; change mfr. part no. to 0757-0280.
  - c. Change R39 and R41 value to 464K.
  - d. Change R65 to R53.
  - ~~e. Change R108 to part no. 0757-0280, 1K. DELETED~~
  - f. Add R109, part no. 0757-0280, 1K.
  - g. Add note to parts list indicating that Q3 and Q7 are 1853-0328 for PCA series 1321; Q4 and Q8 are 1853-0282 for PCA series 1321.

2  
p

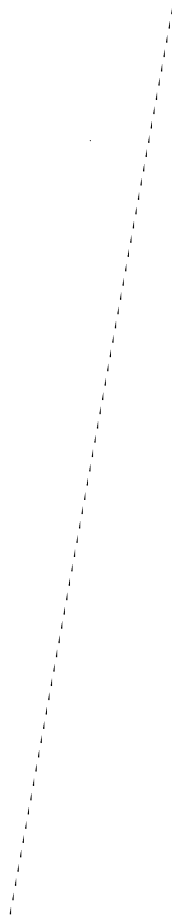



CHANGEDESCRIPTION

- 22 Change 15, this supplement (change dated 9 October 1973), should read "Part 2, page 7-11, figure 7-10. Change connector J6 position diagram to show the dummy plug in the lower right corner position for 10-18 ips operation with 07970-60140 capstan assembly."
- 23 Part 2, page 6-49, figure 6-18.
- Add resistor with index no. 6 between Q1 and Q2.
  - Delete resistor index no. 9 and replace with resistor index no. 10.
- 24 Part 2, page 6-51.
- Index no. 6, change units per assembly from 1 to 2.
  - Delete entire entry for index no. 9.
  - Index no. 10, change units per assembly from 1 to 2.
- 25 Part 2, page 7-7/7-8, figure 7-5.
- Add resistor R113 above R110.
  - Change PCA series code to 1348.
- 26 Part 2, page 7-7/7-8, figure 7-6.
- Change resistor R22 from 38.3K to 46.4K.
  - Add resistor R113, 21.5K between the base of Q2 and U21D, pin 11.
  - Change series code to 1348.
- 27 Part 2, page 6-47/6-48. Change part number of index no. 2 to 0362-0394.
- ~~28 Change 7 of this supplement, first sentence should read: "Part 3, page 3-5. Change the description for item 6 (10-20.9 ips entry) to 4.64K." SUPERCEDED~~
- 29 Change 14 of this supplement. Step "a" should read: "Delete CR10, Q21, R64, R107, and R108." Delete step "e".
- 30 Part 3, page 3-11. Add R43 reference designation to description for index no. 18.
- 31 Part 3, page 4-9/4-10, figure 4-6. Change PCA part no. from 07970-60550 to 07970-62171. Change PCA series code to 1218.
- 32 Part 3, page 4-9/4-10, figure 4-7. Change PCA series code from 1128 to 1218 for PCA part no. 07970-62171.
- 33 Page US-3, change 19 of this supplement, errata. Delete connection between common and R16.
- 34 Part 2, page 7-3/7-4, figure 7-1, 07970-61020 PCA. Add "NOTE 1" to the right of F5 and at the bottom of the PCA diagram, add the following:
- NOTE 1: CONNECTION LABELED 25 IPS A AND B IS APPLICABLE ONLY TO THE HP 7970A AND THEN ONLY WHEN USING A 07970-60020 POWER REGULATOR PCA.
- 35 Part 1, page 1-6, table 1-3. Change WRITE HEAD to READ HEAD CROSSTALK to read: <5% (of read signal) for 12.6 ips to 45 ips and <8% (of read signal) for 12.5 ips and under.

CHANGE

DESCRIPTION

36

Part 3, Title page. Add part number 07970-62297, Series 1350 to the Printed-Circuit Assemblies list and change the series code of PCA 07970-60500 from 1318 to 1350.

37

Part 3, page 3-5. Make the following corrections to the parts list.

a. First three entries should read as follows:

3-2	07970-60500	READ PREAMPLIFIER PC ASSEMBLY A15,10-20.9 ips	
3-2	07970-62297	READ PREAMPLIFIER PC ASSEMBLY A15,10-20.9 ips	
3-2	07970-62000	READ PREAMPLIFIER PC ASSEMBLY A15,21-45 ips	

b. Entries for figure 3-2, index numbers -5 and -6 should read as follows:

-5	0140-0210	CAPACITOR, fxd, 270 pF (C1,C7,C11,C17,C21,C27, C31, C37, C41) (21-45 ips)	9
-5	0160-0363	CAPACITOR, fxd, 620 pF (C1, C7,C11,C17,C21,C27, C31,C37,C41) (10-20.9 ips) (07970-60500 PCA)	9
-5	0160-0911	CAPACITOR, fxd, 4700 pF (C1,C7,C11,C17,C21,C27 C31,C37,C41) (10-20.9) (07970-62297 PCA) . . . . .	9
-6	0698-3136	RESISTOR, fxd, 17.8k, 1%, 1/8W (R1,R5,R9,R13,R17, R21,R25,R29,R33) (21-45 ips)	9
-6	0698-3155	RESISTOR, fxd, 4.64k, 1%, 1/8W (R1,R5,R9,R13,R17, R21,R25,R29,R33) (10-20.9 ips) (07970-62297 PCA)	9
-6	0757-0439	RESISTOR, fxd, 6.81k, 1%, 1/8W (R1,R5,R9,R13,R17, R21,R25,R29,R33) (10-20.9 ips) (07970-60500 PCA)	9

c. Entry for figure 3-2, index number 10 for part no. 0757-0399 should read as follows:

-10	0757-0399	RESISTOR, fxd, 82.5 ohms, 1/8W (R2,R6,R10,R14, R18,R22,R26,R30,R34) (10-20.9) (07970-62297 and 07970-60500 PCA's)	9
-----	-----------	---	---

**CHANGE**

**DESCRIPTION**

38

Part 3, page 4-4, figure 4-3 (sheet 1 of 2). Delete this figure. It is incorrect.

Part 3, page 4-5/4-6, figure 4-3 (sheet 2 of 2). Delete this figure (it is incorrect) and replace it with the figure shown below:

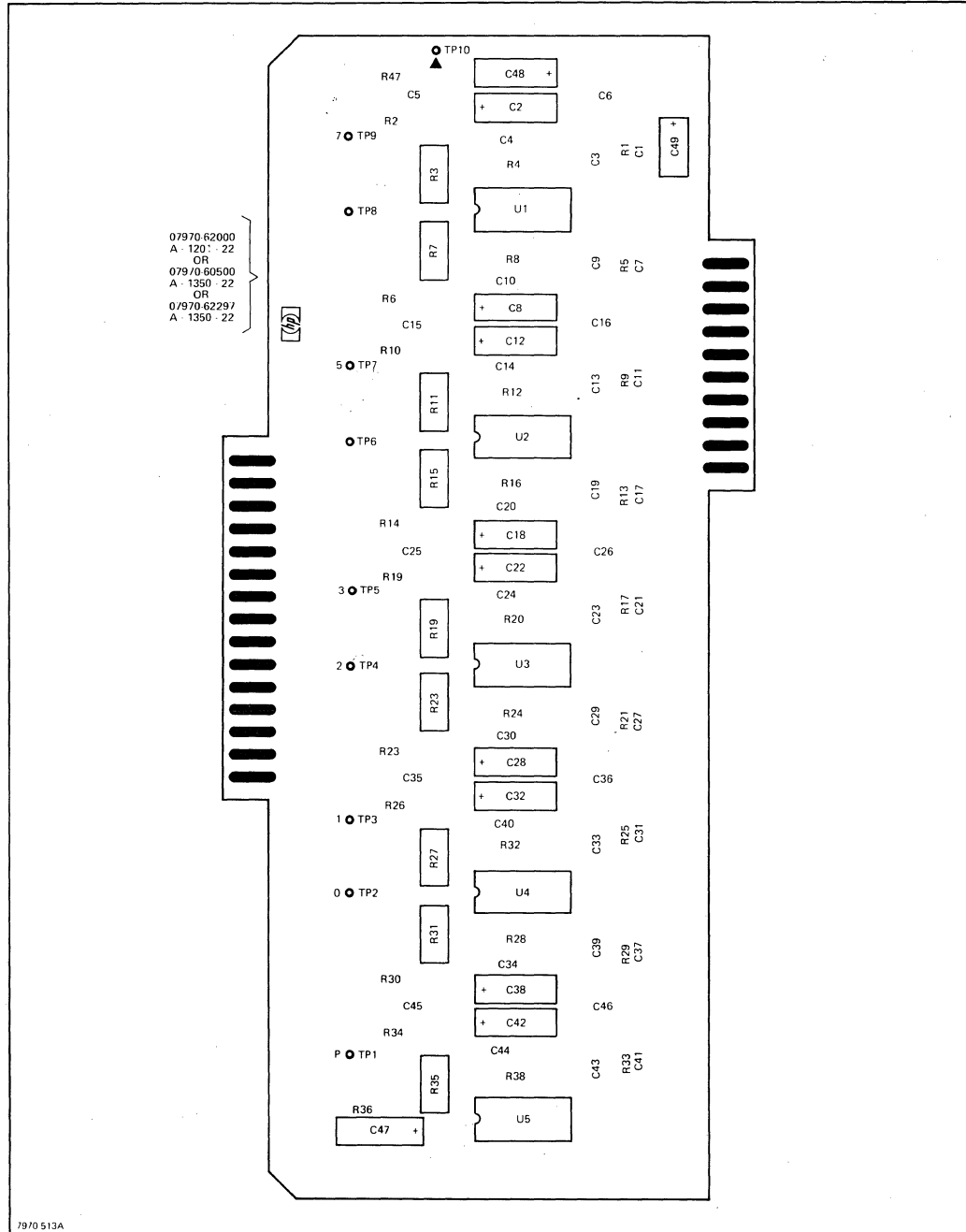

**CHANGE**

**DESCRIPTION**

39

Part 3, page 4-5/4-6, figure 4-4.

a. At the top left of the schematic, the part number/series code block should read as follows:

READ PREAMPLIFIER PC ASSEMBLY A15  
07970-62000, SERIES 1201  
07970-60500, SERIES 1350  
07970-62297, SERIES 1350

b. The note 1, SPEED CRITICAL COMPONENTS table should read as follows:

SPEED (ips)	C1,C7,C11,C17,C21, C27,C31,C37,C41	R1,R5,R9,R13,R17, R21,R25,R29,R33	R2,R6,R10,R14,R18, R22,R26,R30,R34	ASSEMBLY
10-20.9	4700 PF	4.64K	82.5 OHMS	07970-62297
10-20.9	620 PF	6.81K	82.5 OHMS	07970-60500
21-45	270 PF	17.8K	100 OHMS	07970-62000

40

Changes 7, 8, and 28 of this supplement are superceded by changes 35 through 39.

41

Read Modules. Part 3, page 2-3, paragraph 2-16, third sentence. Change "40 percent" to "46 percent". In paragraph 2-16c, first sentence, change range figures from "35 and 45 percent" to "40 and 46 percent".

42

Read Modules. Part 3, page 2-4, paragraph 2-28, first sentence. Change "40 percent" to "46 percent". In paragraph 2-28d, first sentence, change "40 percent" to "46 percent".

43

Read/Read Modules. Part 5, page 2-2, paragraph 2-16, third sentence. Change "40 percent" to "46 percent". In paragraph 2-16c, change range figures from "35 and 45 percent" to "40 and 46 percent".

44

Read/Read Modules. Part 5, page 2-5/2-6, paragraph 2-28, first sentence. Change "40 percent" to "46 percent". In paragraph 2-28d, first sentence, change "40%" to "46 percent".

45

On the face of this supplement, page US-1, under "Instrument Changes", the entry for serial prefix 1343 (change 16) has been deleted. Under "Assembly Changes", the entry for A19, series code 1343, change 16 has been deleted. Disregard change 16 of this supplement. Administrative change.

46

Change 35, this supplement, errata. First sentence was corrected to read: "Part 1, page 1-6, table 1-3."

47

Change 14, this supplement, errata. Step e is marked to avoid misinterpretation when the change is incorporated. Page US-1 has also been altered to avoid misinterpretation as have changes 7, 8, 16, and 28.

48

Density Select Switch, (Read Module). Part 3, page 3-3, figure 3-1. Change PCA A12A1 series code from B-1013A-42 to 1330. In the table on page 3-3 the DESCRIPTION for index number 3-1-4 should read: "DENSITY SELECT PC ASSEMBLY A12A1."

49

Density Select Switch, (Read Module). Part 3, page 4-3, figure 4-1. Change the series code of Density Select PC Assembly A12A1 (part no. 07970-60090) from 1040-42 to 1330.

CHANGE

DESCRIPTION

- 50                    Density Select Switch, (Read Module). Part 3, page 4-3, figure 4-2. The information at the upper left of the schematic should read:  

DENSITY SELECT ASSEMBLY A12 (A12A1)  
07970-60090  
SERIES 1330.

Break the connection from A9P1 pin 7 to ground "P" and enter the notation "N/C."  
On the Control Switch Assembly A11 break the connection shown from A9P1 pin 7 to ground "P" on that assembly.
  
- 51                    Density Select Switch, (Read/Read Module). Part 5, page 3-2, figure 3-1. Change PCA A12A1 series code from A-1039-42 to 1330. In the table on page 3-2 the DESCRIPTION for index number 3-1-4 should read:  

"DENSITY SELECT PC ASSEMBLY, read/read A12A1."
  
- 52                    Density Select Switch, (Read/Read Module). Part 5, page 4-3/4-4, figure 4-1. The HP logo block illustrated in the parts location drawing should read:  

07970-62006  
1330-42
  
- 53                    Density Select Switch, (Read/Read Module). Part 5, page 4-3/4-4, figure 4-2. The information in the lower left of the schematic should read:  

DENSITY SELECT ASSEMBLY A12 (A12A1)  
07970-62006  
SERIES 1330.

Break the connection from A9P1 pin 7 to ground "P" and enter the notation "N/C."  
On the Control Switch Assembly A11 break the connection shown from A9P1 pin 7 to ground "P" on that assembly.
  
- 54                    Page US-1, Instrument serial prefix 1408 is added which incorporates A16 Control and Status PCA series code 1348 changes. Administrative change.
  
- 55                    Pages US-1, US-7, and US-8 this supplement. Instrument serial number prefix 1348 deleted. Administrative change. Changes numbered 46, 47, 54 wording corrected.
  
- 56                    Capstan Servo. Part 2, page 6-32, figure 6-12. Change PCA series code on the figure from 1322 to 1410.
  
- 57                    Capstan Servo. Part 2, page 6-33, table 6-3.
  - a. Change PCA series code, under Reference Designation A9, from 1322 to 1410.
  - b. Change the part numbers for Q5 and Q6 from 1854-0576 to 1854-0490. Change the Mfr Code from 80131 to 04713 (Motorola). Mfr. Part Number is to be SJ2376 (2N3773).
  
- 58                    Capstan Servo. Part 2, page 6-53. Add the following in numerical sequence in the table:  

1854-0490	04713	2N3773
-----------	-------	--------
  
- 59                    Capstan Servo. Part 2, page 7-11/7-12, figure 7-10. Change series code block from 1322 to 1410.
  
- 60                    Part 2, page 6-8, index number 6-1-122, errata. The DESCRIPTION column figure reference should read: (see figure 6-17 for details).
  
- 61                    Transformer Assembly. Part 2, page 6-47/6-48. Change figure index number 6-17-28 part number from 3101-0003 to 3101-0646. (Power switch change.)



CHANGE

DESCRIPTION

- 62 Transformer Assembly. Part 2, page 6-47/6-48. Change item 6-17-18 part number from 2110-0303 to 2110-0380. Change the description rating from 2A to 2.5A.
- 63 Transformer Assembly. Part 2, page 6-54, table 6-1. Delete part number 2110-0303 from the table and add:  
2110-0380 | 71400 | MDA 2-1/2
- 64 Transformer Assembly. Part 2, page 7-3/7-4, figure 7-2. Change F2 rating in assembly A19 from 2ATT to 2-1/2ATT.
- 65 Transformer Assembly. Part 2, page 6-4, figure 6-1. Nomenclature on F2 in lower left of figure now to read 2-1/2 AMPS. All figures showing this view now to have F2 at 2-1/2 AMPS.
- 66 Capstan Servo. Part 2, page 1-1, paragraph 1-13, last sentence. Capstan Servo PCA should read A6, not A9.
- 67 Capstan Servo. Part 2, page 3-3, make the following correctibns.  
a. Paragraph 3-27, last part of the first sentence should read:  
. . . and measuring fast forward, reverse, start and stop characteristics.  
b. Paragraph 3-28, last part of the first sentence should read:  
. . . across the 1.5 ohm 1 percent resistance (comprised of R21 and R22 in parallel).  
c. Paragraph 3-29, fourth sentence should read:  
For the following tests reference frequencies are based on using the signal that will be available from the . . . .
- 68 Capstan Servo. Part 2, page 3-3, replace paragraphs 3-30 through 3-33 with the following paragraphs.  
3-30. **START MEASUREMENT.** Capstan start (and stop) measurements are made for both forward and reverse tape motion. To make these measurements it is necessary to apply rapidly alternating active and inactive conditions (squarewave signal) of the FWD (or REV) signal to the capstan servo PCA. This produces repetitious start (and stop) ramps for oscilloscope display. Time duration of the active and inactive levels of the FWD (or REV) signal must be greater than the 100 percent time of the start ramp to be measured. (The start ramp time is variable, depending on tape speed.) Start ramp delay time is measured observing the tachometer output. The capstan tachometer voltage will reverse polarity when direction (forward/reverse) is changed. The oscilloscope is synchronized for these measurements on the forward (or reverse) command to start the sweep. The start ramp 90 percent time measurement is made by observing the bi-polar ramp generator slope output (refer to the adjustment procedure) or by observing the output from a preamplifier channel while reading a tape (forward only). (There will be no observable difference in the preamplifier output waveforms if forward and reverse are used but forward only should be used.) The tape to be read may be any previously recorded tape, preferably at 800 cpi, as this provides the best resolution where measurements from preamplifier outputs are required. Wavelength accuracy is not a factor in this test. Do not make measurements during the read-after-write operation. The stop-ramp time measurement is described in paragraph 3-32. Start and stop

CHANGE

DESCRIPTION

68  
(cont.)

distance calculation steps are described in paragraphs 3-31 and 3-33 respectively. Proceed as follows:

- a. Start ramp delay time, the time (following a forward or reverse command) required for the capstan tachometer voltage to reach a value that is greater than 0 Vdc but less than 3 percent of the value reached at normal drive speed, is measured as described below.
  - (1) Connect the oscilloscope probe to the TACH test point on the capstan servo PCA.
  - (2) Synchronize the oscilloscope sweep on the negative edge of the  $\overline{\text{FWD}}$  signal at TP9 on the control and status PCA (for start ramp delay time in forward tape motion) or at TP5 ( $\overline{\text{REV}}$  signal) of the control and status PCA (for reverse).
  - (3) See tape speeds and times listed in step 3-30, b, (3). Adjust oscilloscope sweep speed and vertical deflection then measure start ramp delay time for forward, then reverse tape motion. It is the time interval between the start of the oscilloscope sweep and the time the ramp waveform reaches 3 percent of its steady-state value. (About 0.25 divisions up if the full 8 vertical division of the oscilloscope face were used.) Start ramp delay time, for both forward and reverse tape motion, should be  $0.5 \pm 0.5$  ms.
  
- b. Start ramp 90 percent time may be measured as outlined in steps (1) through (3) below (similar to the adjustment procedure) or by the method outlined in step (4) below.
  - (1) Connect the oscilloscope probe to the FWD/REV test point on the capstan servo PCA.
  - (2) Synchronize the oscilloscope sweep on the negative edge of the  $\overline{\text{FWD}}$  signal at TP9 on the control and status PCA.
  - (3) With alternate active/inactive forward (synchronous speed forward) commands applied adjust sweep speed and vertical deflection to measure the start ramp 90 percent time. Also, measure the start ramp 90 percent time for synchronous speed reverse tape motion. The start ramp 90 percent time is the time interval on the start ramp, from 0 volts to 90 percent of the steady-state value. (See the adjustment procedure.) This time is dependent on tape speed. Values for some common tape speeds are listed below. Tolerances are  $\pm 0.2$  ms for forward tape motion and  $\pm 0.3$  ms for reverse tape motion. For any unlisted speeds, use the following equation to derive start ramp 90 percent time:

$$T \text{ (in ms)} = \left( \frac{0.375}{\text{TAPE SPEED (in ips)}} - 0.001 \right)$$

CHANGE

DESCRIPTION

68  
(cont.)

(Stop-ramp time should be within  $\pm 0.5$  ms of the start ramp time.)

TAPE SPEED (in ips)	T (in ms)
12.5	26.1
18.75	17.1
22.5	14.1
25.0	12.6
37.5	8.1
45.0	6.6

- (4) The start/stop envelope may also be observed (probe on preamplifier channel 3 output) to measure start-ramp 90 percent time. The time measured is the time (following a  $\overline{\text{FWD}}$  command) required for the analog output of any preamplifier track (usually preamplifier channel 3) to reach 90 percent of the peak-to-peak (or 0-to-peak) value established while reading an all "1's" tape under steady-state drive conditions. The time is a function of tape speed. Time limits in step (3) above also apply. The measurement should be made for forward tape motion only. The oscilloscope is synchronized on  $\overline{\text{FWD}}$  command test point TP9 on the control and status PCA.

3-31. **START DISTANCE.** Start distance is calculated as follows:

- a. Determine start ramp time. This is the time required to accelerate the tape from zero ips to the drive speed. It is determined by subtracting the measured start ramp delay time (paragraph 3-30, a.) from the start ramp 90 percent time (paragraph 3-30, b.).
- b. Determine start balance time. This is the time difference between the start ramp 90 percent time measured and the specified start time for the tape speed involved. This period of time is allowed to provide a balance in tape distance as it offsets the time delay at full drive speed represented by the stop-ramp delay time.
- c. One-half of the start-ramp time plus the start balance time (both in milliseconds) multiplied by the tape speed in inches per second equals the start distance (in inches  $\times 10^{-3}$ ). Specification is  $0.187 \pm 0.020$  inch.

3-32. **STOP MEASUREMENT.** Stop measurements (for both forward and reverse) are made as follows.

- a. To measure stop ramp delay time, the setup is made as for the start ramp 90 percent time (envelope measurement, paragraph 3-30, b, (4)). The stop ramp delay time is the time (following removal of a forward command) required for the analog output of any preamplifier to fall to a peak-to-peak (or 0-to-peak) value that is less than 100 percent but greater than 97 percent of the value

CHANGE

DESCRIPTION

68  
(cont.)

established under steady-state drive conditions while reading an all "1's" tape. Specification is  $0.5 \pm 0.5$  ms.

- b. To measure the stop ramp 90 percent time, the setup is made as for the start ramp delay time (paragraph 3-30,a). The stop ramp 90 percent time (following removal of the forward or reverse command) is the time required for the capstan tachometer voltage to reach a level between 3 percent of normal drive speed value and 0 Vdc. The specification is a function of tape speed. (See speeds and times in paragraph 3-30, b, (3)). The stop ramp time should be within  $\pm 0.5$  ms of the start ramp time.

3-33. STOP DISTANCE. Stop distance is calculated as follows.

- a. Determine stop ramp delay time (paragraph 3-32, a).
- b. Determine stop ramp time. This is the time required to decelerate the tape to zero ips from the drive speed. It is determined by subtracting the measured stop ramp delay time (paragraph 3-32, a) from the measured stop ramp 90 percent time (paragraph 3-32, b).
- c. The stop-ramp delay time plus one-half the stop ramp time (both in milliseconds) multiplied by the tape speed in inches per second equals the stop distance (in inches  $\times 10^{-3}$ ). Specifications is  $0.187 \pm 0.020$  inch.

69

Capstan Servo. Part 2, page 5-6, paragraph 5-35 c. Replace the note after step c with the following note.

Note: On HP 180 Oscilloscopes, the full vertical spacing is 8-divisions. If the full vertical face is used there is a scale mark at 7.2 divisions up from the bottom which may be used to measure the time at the 90 percent level.

70

Capstan Servo. Part 2, page 5-6, table 5-1. Add the following note at the bottom of the table.

Note: Tolerance for 90% time using the forward command is  $\pm 0.2$  ms. Stop ramp time should be within  $\pm 0.5$  ms of the applicable start ramp time.

CHANGE

DESCRIPTION

71

Part 2, page 6-7. Change magnetic tape head assembly A1 entries to be as shown below:

6-1-77	07970-60580 or 07970-62206	. MAGNETIC TAPE HEAD ASSEMBLY A1, 9-track, write/read, 21 - 45 ips (see figure 6-9 for details)	. 1
	07970-60581 or 07970-62204	. MAGNETIC TAPE HEAD ASSEMBLY A1, 7-track, write/read, 21 - 45 ips (see figure 6-9 for details)	. 1
	07970-60582 or 07970-62202	. MAGNETIC TAPE HEAD ASSEMBLY A1, 9-track, read, 21 - 45 ips (see figure 6-9 for details)	. 1
	07970-60583 or 07970-62200	. MAGNETIC TAPE HEAD ASSEMBLY A1, 7-track, read, 21 - 45 ips (see figure 6-9 for details)	. 1
	07970-60584 or 07970-62203	. MAGNETIC TAPE HEAD ASSEMBLY A1, 7-track, write/read, 10 - 20.9 ips (see figure 6-9 for details)	. 1
	07970-62031 or 07970-62211	. MAGNETIC TAPE HEAD ASSEMBLY A1, 9-track, write/read, 10 - 20.9 ips (see figure 6-9 for details)	. 1
	07970-60586 or 07970-62199	. MAGNETIC TAPE HEAD ASSEMBLY A1, 7-track, read, 10 - 20.9 ips (see figure 6-9 for details)	. 1
	07970-60587 or 07970-62201	. MAGNETIC TAPE HEAD ASSEMBLY A1, 9-track, read, 10 - 20.9 ips (see figure 6-9 for details)	. 1
	07970-60588 or 07970-62207	. MAGNETIC TAPE HEAD ASSEMBLY A1, 7/9-track, read/read, 10 - 20.9 ips (see figure 6-9 for details)	. 1
	07970-60589 or 07970-62208	. MAGNETIC TAPE HEAD ASSEMBLY A1, 7/9-track, read/read, 21 - 45 ips (see figure 6-9 for details)	. 1

NOTE: The two head assemblies listed for each tape unit configuration are interchangeable; either may be used.

72

Part 2, page 6-23. Replace page 6-23 with page 6-23 accompanying this supplement.

**CHANGE**

**DESCRIPTION**

73

Part 2, page 6-17, figure 6-7. Add item 27 as shown below.

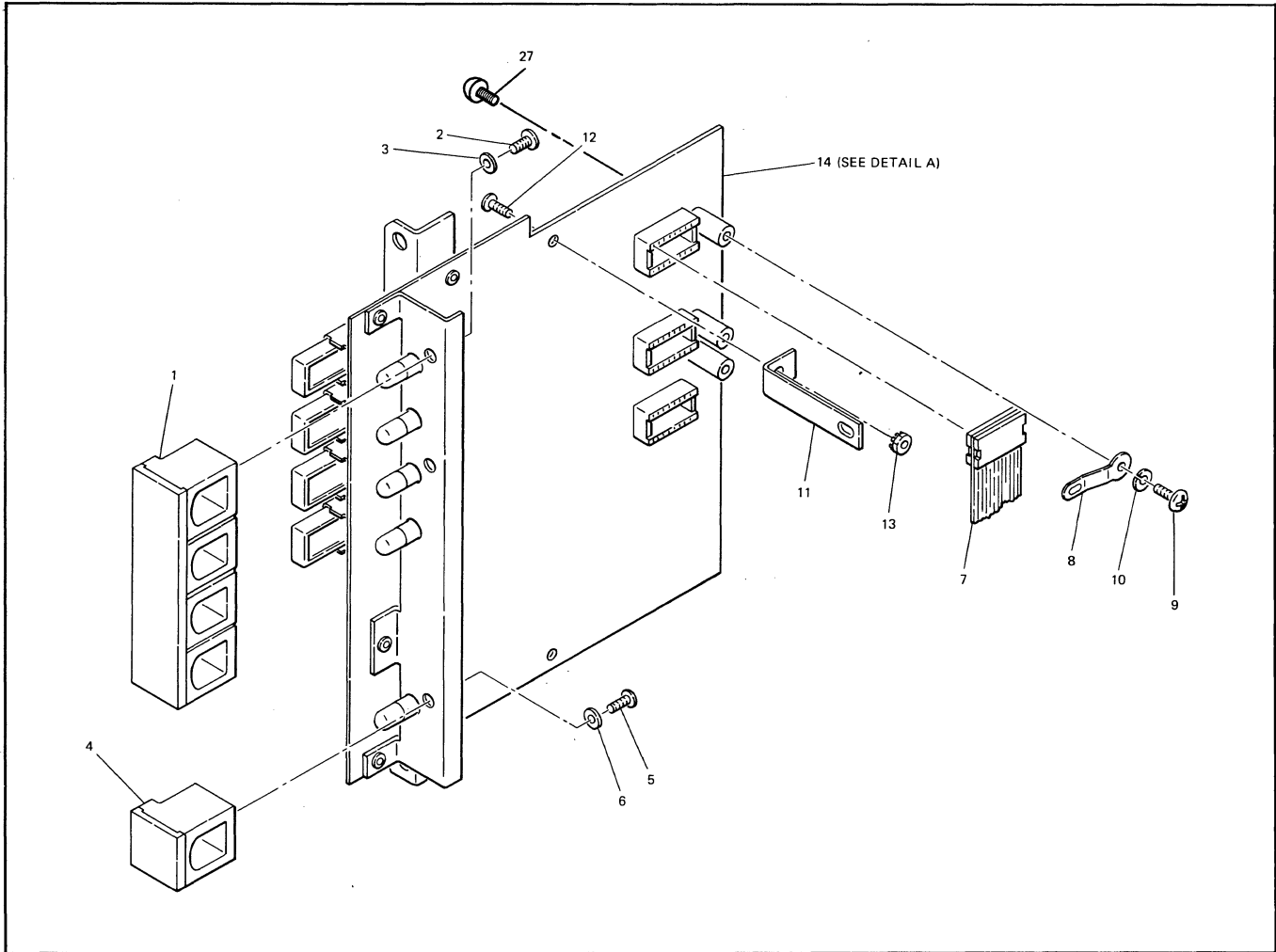

7970-A-050A

74

Part 2, page 6-19/6-20. Add item 27 as follows:

[ 27 ] Coml [ . . . BUMPER, rubber, 0.5 in OD, 6-32 . . . ] 1 ]  
shank

75

Part 1, page 2-9. Replace page 2-9 with part 1, page 2-9 accompanying this supplement.

76

Part 2, title page. Add series 1426 to part number 07970-61150.

CHANGE

DESCRIPTION

- 77 Part 2, page 6-21, table with figure 6-8. At the bottom of the table for part number 07970-61150, add the following note.
- ALL PHOTONSENSE HEAD ASSEMBLIES, A2, WITH SERIES CODE 1426 AND ON (AND ALL A2 ASSEMBLIES NEEDING REPAIR) SHOULD HAVE THE ENTIRE ASSEMBLY (PART NO. 07970-61150) REPLACED IF A MALFUNCTION OCCURS. FACTORY MATCHED PHOTOTRANSISTOR/RESISTOR COMPONENTS Q1, Q2, R2, R4 FROM DATE 1426 ON MAKE THIS PROCEDURE MANDATORY.
- 78 Part 2, page 7-5/7-6, figures 7-3 and 7-4. Make the following changes and additions to the parts location and schematic diagrams:
- a. Beside assembly A2 (the photosense head assembly part number 07970-61150) add the same note as shown in step 77 of this supplement.
  - b. Add series code 1426 to assembly A2.
  - c. On the schematic for 07970-61150 pin 5 should be shown tied to common, pin 6 should be shown connected to +5V. (Reverse the designations for pins 5 and 6 at A2.)
- 79 Part 5, title page. Add 07970-62299, Series 1350 to the assemblies covered information.
- 80 Part 5, page 3-2, figure 3-1 and the associated parts list. Make the following changes and additions:
- a. Add a resistor labeled index number 7 immediately above the existing index number 5 that is uppermost in the location drawing. Place an asterisk beside this index number.
  - b. Place a note in the diagram as follows:  
  
\*RESISTOR USED ON ASSEMBLIES WITH PART NUMBER 07970-62299, SERIES CODE 1430 AND ON.
  - c. In the parts list add part number 07970-62299 in parentheses immediately after the present part number 07970-62088.
  - d. Place an asterisk after part no. 07970-62006 and 07970-60620 with the following note at the bottom of the table.  
  
\*APPLICABLE FOR ASSEMBLIES PART NO. 07970-62088 ONLY.
  - e. In the description for part no. 0757-0428 add R7\*\* (with a double asterisk) and change the UNITS PER ASSY number to 4\*\* (add the double asterisk). Also add part no. (07970-62079)\*\* in parentheses after part no. 07970-60620. Put the following note at the bottom of the table:  
  
\*\*APPLICABLE FOR ASSEMBLIES PART NO. 07970-62299 AND ON.
- 81 Part 5, page 4-3/4-4, figure 4-1. To the parts location add (07970-62299, 1350-22) in parentheses under the present part no. and series code. Add R7\* immediately above R2. Put a note in the diagram as follows:  
  
\*R7 USED ON PART NO. 07970-62299 SERIES CODE 1430 AND ON.
- 82 Part 5, page 4-3/4-4, figure 4-2. Make the following additions and changes in the schematic:
- a. Add part no. 07970-62299, series code 1350 in parentheses after the present entry.

CHANGEDESCRIPTION

82  
(cont)

- b. Show R7\* connected from +5V to a new eyelet "C" with an asterisk shown.
- c. Add new eyelet "D" connected by a dashed line to eyelet "B" with an asterisk shown.
- d. Show connector A9P2 with eyelets A, B, C, D connected to A9P2-1, 3, 2, 4 respectively for part number 07970-62299. Designate wiring as shown, for old boards. Put a note in the diagram as follows:

\*USED ON PART NO. 07970-62299 SERIES CODE 1350 AND ON.

83

Part 5, pages 3-5B, 3-5C, and 3-5D. Resistors R1, R14, R27, R40, R53, R66, R79, R92, and R105; change value to 100K ohms. Change HP and MFR part numbers to 0757-0465.

84

Part 5, page 4-5A, schematic diagram. Change value of resistors R1, R14, R27, R40, R53, R66, R79, R92, and R105 to 100K ohms.

85

Part 2, page 6-34. Make the following changes to the parts list:

- a. Index no. 23. Change the description to "LUG, solder, no. 4."
- b. Index no. 24. Change the part no. to "2360-0123," description to "SCREW, 6-32, pozi."
- c. Index no. 25. Change part no. to "0362-0321," description to "LUG, crimp, no.6."
- d. Add index no. "36," part no. "2420-0002," description "NUT, no. 6," units per assy "2."
- e. Add index no. "37," part no. "2420-0001," description "NUT, lock, no. 6," units per assy "1."

86

Replace part 2, page 6-46 with the changed page provided by this supplement.