

Manual 325-068
February 1982



integrated
SYNCHRONOUS
dataspeed[®] **40**

RECEIVE-ONLY PRINTER STATIONS

SERVICE MANUAL

SERVICE MANUAL
FOR
INTEGRATED SYNCHRONOUS "DATASPEED*" 40 (40C303AC) RECEIVE-ONLY PRINTER
STATION ARRANGEMENTS

Contents	Section	Issue
Installation	582-202-200	2
Wiring	582-202-400	2
Testing and Troubleshooting	582-202-500	2
Disassembly/Reassembly and Parts	582-202-700	2
Routine Maintenance	582-202-750	2
Station and Component Removal	582-200-290	2

For DATASPEED 40 components refer to Service Manual 325-073.

*Registered Trademark of AT&TCo.

INTEGRATED SYNCHRONOUS "DATASPEED*" 40
RECEIVE-ONLY PRINTER (ROP) STATION
INSTALLATION

CONTENTS	PAGE	1. GENERAL
1. GENERAL	1	1.01 This section contains information for installing the Integrated Synchronous DATASPEED 40 Receive-Only Printer (ROP) Station. The Integrated Synchronous ROP is used in the following services: (2) Switched-Network using Data Set 201C, 208B or 212A, (2) Multipoint Private Line using Data Set 201C, 208A or 209A; and (3) Two-Point Nonselective Private Line (point-to-point private line) using Data Set 201C, 208A or 209A.
2. TECHNICAL DATA	3	
3. UNPACKING	6	
PEDESTAL	6	
TRACTOR FEED PRINTER CABINET	6	
FORMS ACCESS PRINTER CABINET	7	1.02 This section is reissued to include Option 179 (WACK/BUFFER Control) and information pertaining to Data Set 212 and forms access arrangements. Since this is a general revision, no revision arrows have been used to denote significant changes.
4. PREOPTIONING DISASSEMBLY ...	8	
5. FIELD OPTIONS AND DESCRIPTIONS	10	<i>Note:</i> When ordering tools or replaceable components, unless otherwise specified, prefix each part number with the letters "TP" (ie, TP406173).
PRINTER OPTIONS	10	
CONTROLLER OPTIONS	13	
GROUND OPTION	21	1.03 Circuit Card Handling Procedures:
6. OPTION ACTIVATION	22	<i>Warning:</i> To avoid possible internal damage to the MOS devices, or card with MOS devices, due to electrical static discharge by service personnel, the following should be observed. All personnel handling MOS devices, or circuit cards with MOS devices, must wear a 346392 static discharge strap adjusted to make firm contact with the skin at all times † (Fig. 1).
TRANSMITTING CODES	29	
ACTIVATING PRINTER OPTIONS	33	
ACTIVATING CONTROLLER OPTIONS	48	† Service personnel are <u>never</u> to be connected directly to ground but rather through a high resistance discharge path of a minimum of one megohm where 115 V ac is present. This resistance is built into the 346392 static discharge strap.
ACTIVATING DATA SET OPTIONS	59	
7. FINAL ASSEMBLY	64	

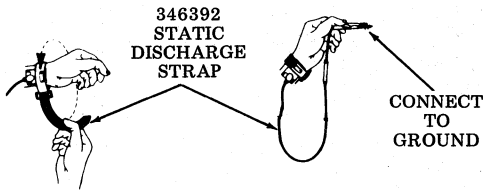

Fig. 1—346392 Static Discharge Strap

1.04 Data set options are given in this section but other information on data set installation (such as connections) must be obtained by reference to the appropriate BSP section, which is referenced for each data set.

1.05 The printer used in the integrated controller station may be an 80- or 132-column printer.

1.06 Tools and Supplies: The following tools and supplies may be required for installation or servicing of DATASPEED 40 ROP with integrated synchronous controller.

(a) Tools

*Wrench	3/16" socket	125752
Wrench, open end	3/8"	125765
Wrench, open end	3/16" and 1/4"	129534
Wrench, open end	5/16" and 3/8"	152835
Wrench, open end	3/4"	129537
Nut driver handle		135676
Nut driver bit	1/4"	135677
Nut driver bit	5/16"	135678
*Screwdriver	1/8", 2" blade	95368
Screwdriver	1/4", 6" blade	100982
Screwdriver	(Blade less than 5/32")	94647
*Wrench, Allen	0.062	124682
*Tweezers		151392
*Spring hook (pull)		142554
*Spring hook (pull)		75765
*Spring hook (push)		75503
*Scale	6"	95960
*Scale, spring	8 oz	110443
*Scale, spring	32 oz	110444
Pliers, long nose		108285
Pliers, retaining ring		160396
Extractor, keyswitch		346257
Extractor, keytop		346260
Extractor, terminal		182697
Extractor, terminal		341983
Extractor, terminal		402840
Gauge adjusting — 80-column printer		402617
Gauge, left — 132-column printer		402716
Gauge, right — 132-column printer		402717
Gauge, backup bar — 80- and 132-column printers		402868
Gauge, type pallet depth — 80- and 132-column printers		402878
Pliers, sidecutters w/insulated handles		408071 (Klein D219-4C or equivalent)
Test Cord — 132-column printer		402779
Printer Test Assembly		408646
Test Cable		408648
Test Cable		408650

*Part of 113778 universal tool kit.

(a) Tools (Cont)

Interlock Strapping Plug — 80-column printer	402782
Static Ground Strap	346392
Cleaning brush, type face	151394
Power Test Cord	402871
Soldering Iron, Weller Model W-MCP-750 with MP2C Tip or equivalent	
Desoldering Tool EDSYN Model MMS005 Soldapult® or equivalent	
Bag, Anti-Static (Printer Circuit Card)	406260

(b) Supplies

- Grease: 143484 (Mobil No. 2, 1 lb can)
- 145867 (Mobil No. 2, 4 oz tube)
- TKS 103 (Beacon 325, 5 lb can)

- Oil: KS-7470

- Degreaser: Freon (TF) 337449 (6 oz can)

- Ribbon: 402444 or approved equivalent

2. TECHNICAL DATA

2.01 Power Source Requirements: 115 V ac ± 10% ac at 60 Hz ±0.5 Hz or 50 Hz ±0.5 Hz from an unswitched standard 3-wire grounding type receptacle located within 8 feet of the ROP set location. One additional receptacle is required for data set except when terminal includes pedestal equipped with 7-receptacle convenience strip.

2.02 Maximum In Rush Current: 20 Amp not exceeding 3 cycles at nominal 115 V ac input.

2.03 Operating Power Consumption and Heat Generation at nominal 115 V ac input.

<u>Component</u>	<u>Current</u>	<u>Power</u>	<u>Heat</u>
Integrated Synchronous ROP Set (motor OFF)	1.0 Amp	115 VA	392 BTU
Integrated Synchronous ROP Set (motor ON)	2.0 Amps	230 VA	784 BTU

Note: The ROP power supply was designed to supply power for the set configurations described in this section. Power should not be used for any other purpose without first considering the limitations of the power supply.

2.04 Environmental Restrictions (operating):

Ambient Temperature +40°F to +110°F
 Relative Humidity . . . 2% to 95% (noncondensing)
 Altitude Sea level to 10,000 feet

2.05 Weight (approximate) Unpacked:

80-Column Tractor Feed Printer Unit	41 lbs
80-Column Tractor Feed Printer Cabinet	43 lbs
132-Column Tractor Feed Printer Unit	56 lbs
132-Column Tractor Feed Printer Cabinet	53 lbs
Forms Access Printer Cabinet	111 lbs
Pedestal	approximately 56 lbs
Data Set	Up to 14 lbs (dependent on type)

2. TECHNICAL DATA (Cont)

2.06 Dimensions

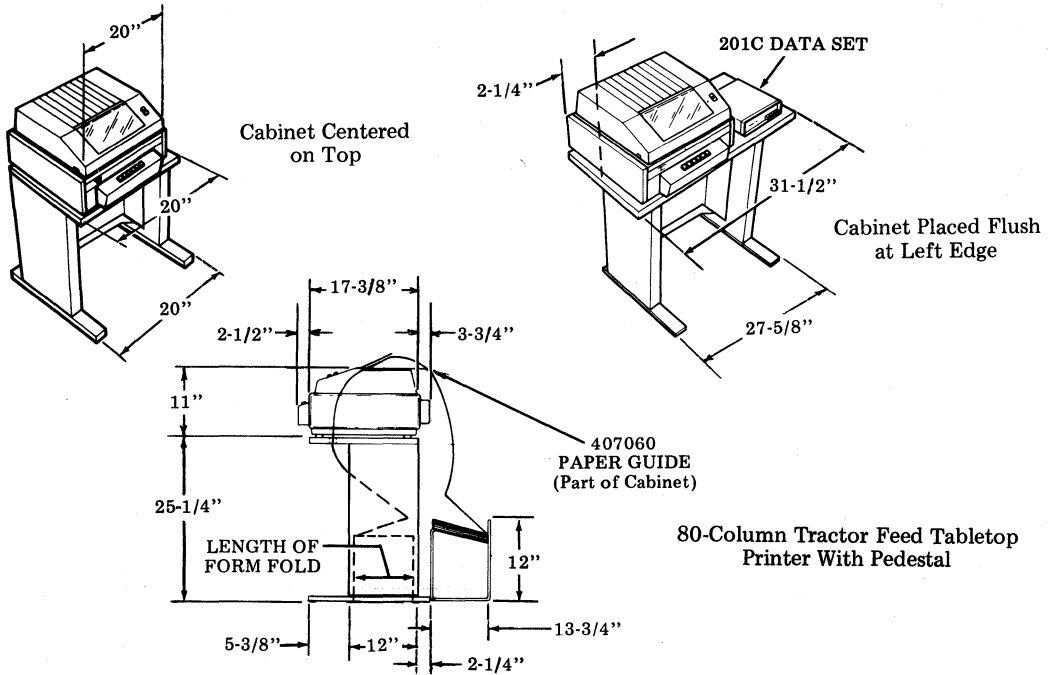

Note: The 132-column tractor feed printer dimensions are similar to those for the 80-column tractor feed printer except that the width is 27-5/8 inches instead of 20 inches. A 407061 paper guide is furnished with each cabinet. The pedestals shown are typical. They are not part of the set USOC. Three widths of pedestals are available: 20 inch without door, 27-5/8 inch without door and 24-1/2 inch with door. Tops for the pedestals come in a variety of widths except that the 20 inch pedestal comes with a 20 inch wide top (with 11 inch slot) only.

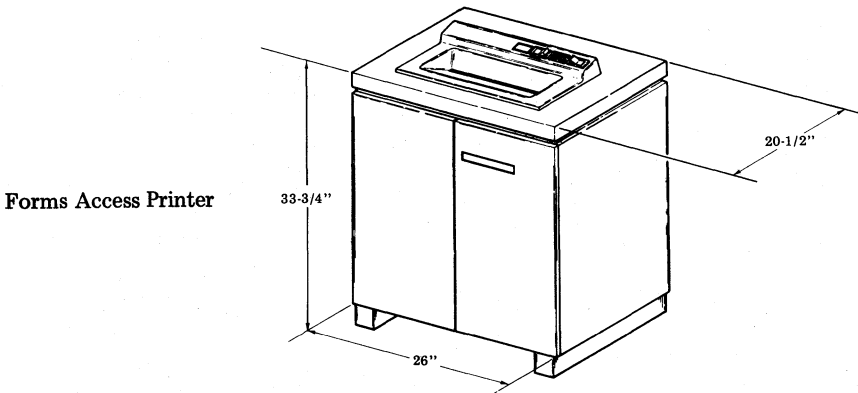
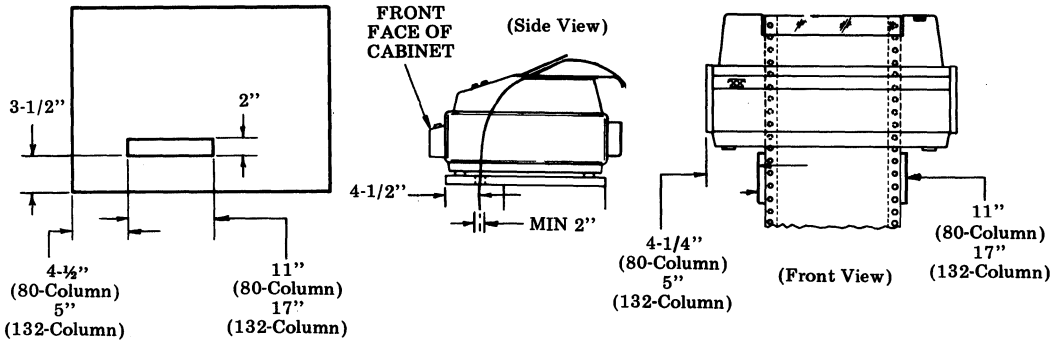

Fig. 2—Integrated ROP Station Dimensions

2.07 Customer Provided Tables: When a pedestal with a slotted top is not specified for use with the tabletop tractor feed printer, the following provisions must be observed to allow for paper handling:

- (a) An opening in the printer cabinet mounting surface sufficient to allow the paper to pass up through the printer in the location shown in Fig. 3.



Typical Cutout Location in Table Top

Note: Printer cabinet assumed mounted flush with front and left edge of table top.

Fig. 3—Paper Opening Requirements for Customer-Provided Tables

- (b) Sufficient height of mounting to allow paper insertion and accumulation (Fig. 4).

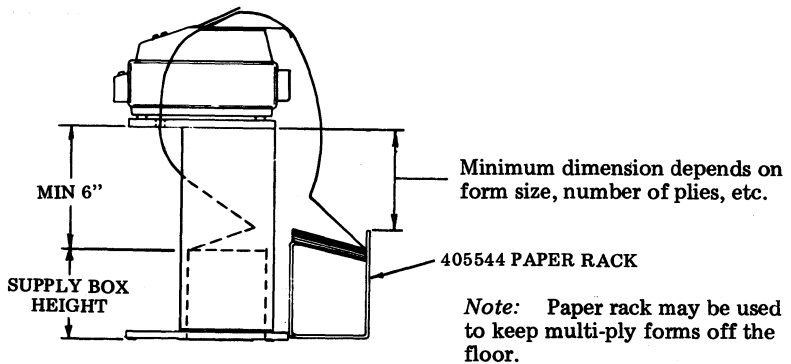

Fig. 4—Height Requirements for Customer-Provided Tables

3. UNPACKING

3.01 Before unpacking the cartons, confirm the customer order with the unit codes marked on the cartons.

3.02 Be sure to observe all safety precautions in lifting the cartons, etc. Safety glasses should be worn during installation. Read all unpacking instructions marked on the cartons.

3.03 For field installation, the integrated ROP may be shipped from the Service Center in the original shipping cartons. Units without pedestals are shipped in two cartons, one for the printer and the other for the cabinet (including the controller). For units with pedestals, two additional cartons are shipped, one for the pedestal base and the other for the pedestal top.

3.04 The cabinet should be unpacked before the printer so that the printer can be placed on it.

PEDESTAL

3.05 Carefully trim carton containing pedestal upside down and cut tape. Fold carton flaps out (Fig. 5).

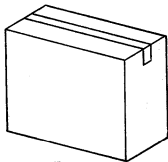

Fig. 5—Pedestal Carton

3.06 Turn carton and its contents upright. Lift carton up and off of pedestal (Fig. 6).

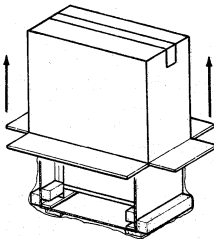

Fig. 6—Pedestal Carton Lifted Up

3.07 Remove tape and packing details (Fig. 7). Place pedestal in position where it is to be located.

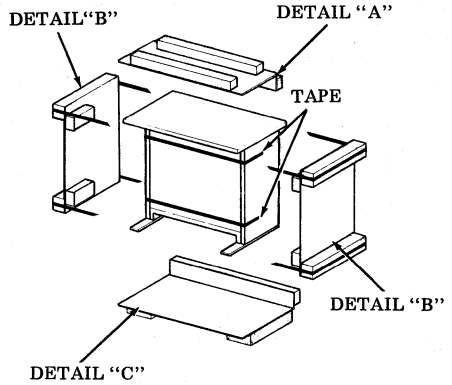

Fig. 7—Typical Packing Details and Pedestal

TRACTOR FEED PRINTER CABINET
(With Opcon)

3.08 Turn carton bottom upside down. Cut tape and open bottom flaps outward. Return box and contents to upright position, keeping bottom flaps folded out (Fig. 8).

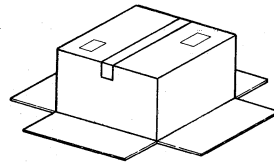
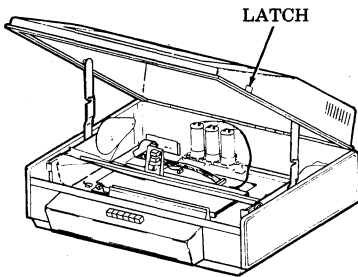

Fig. 8—Printer Carton

3.09 Lift carton off and remove plastic details from around cabinet. Remove bag covering cabinet. Remove bag containing keytops and set aside for possible later use.

- 3.10 Open printer cabinet by depressing latches on both sides of cover and lifting up (Fig. 9). Remove paper guide stored inside of cabinet.



Note: The integrated synchronous controller mounting hardware and the controller will come assembled in the cabinet.

Fig. 9—Printer Cabinet

- 3.11 Close cover and snap paper guide into position (Fig. 10).

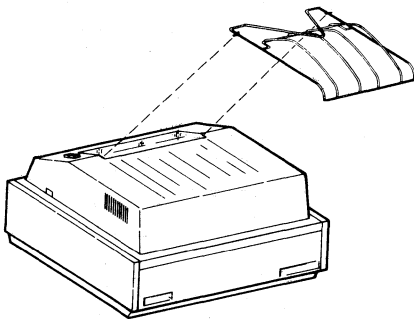

Fig. 10—Paper Guide

FORMS ACCESS PRINTER CABINET

- 3.12 Remove steel strap from bottom of carton. Fold carton flaps outward (Fig. 11).

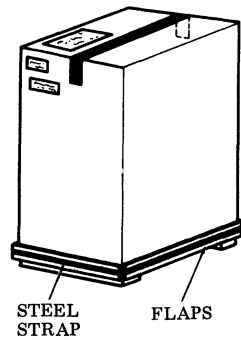

Fig. 11—Forms Access Printer Cabinet Carton

- 3.13 Lift carton up and off of forms access printer cabinet. Remove plastic bag covering cabinet. Remove tape, packing details A, B, C and D and plastic bag from bottom of cabinet (Fig. 12).

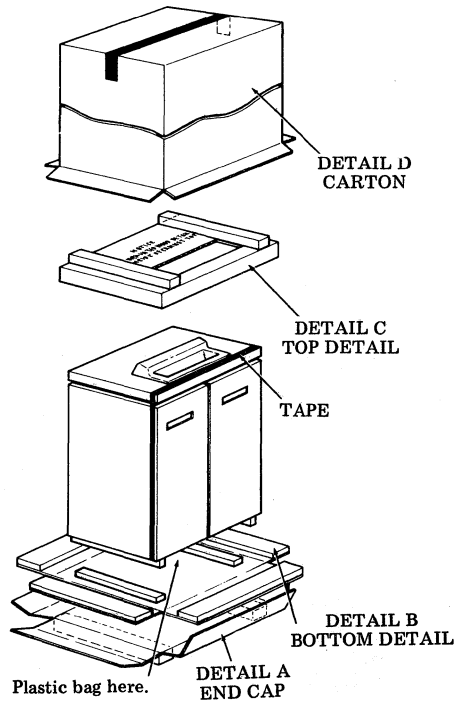

Fig. 12—Forms Access Printer Cabinet Carton Lifted Up

3.14 Open front doors (left first) and depress latch button, open cabinet top and remove two screws and wood detail. (Fig. 13).

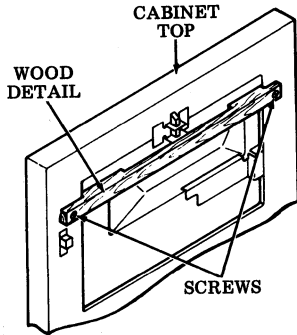

Fig. 13—Forms Access Printer Cabinet Top

PRINTER

3.15 Refer to Section 582-210-200 for unpacking instructions.

4. PREOPTIONING DISASSEMBLY

4.01 The integrated synchronous ROP should be optioned per the customer order at the Service Center. However, it may be necessary to change options per customer request or because of option incompatibility, at the time of installation.

4.02 The controller is shipped in the printer cabinet and must be removed from the cabinet in order to do any optioning of it.

4.03 To remove controller:

Note: Refer to 1.03 for controller handling procedures.

Tabletop Arrangement

(a) Loosen nut at each end of paper guide (Fig. 4).

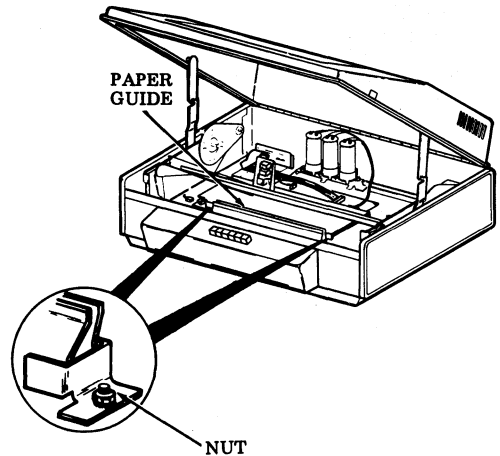

Fig. 14—Controller Removal

- (b) Slide paper guide to left, raising right end to clear the nut; slide paper guide to right and remove.
- (c) Unplug P3, P5, P6 and P21 connectors from the circuit card (Fig. 15).
- (d) Slide controller circuit card forward, tilt up and remove. Use care to avoid snagging circuit components or option switches on the rear edge of the printer cradle.

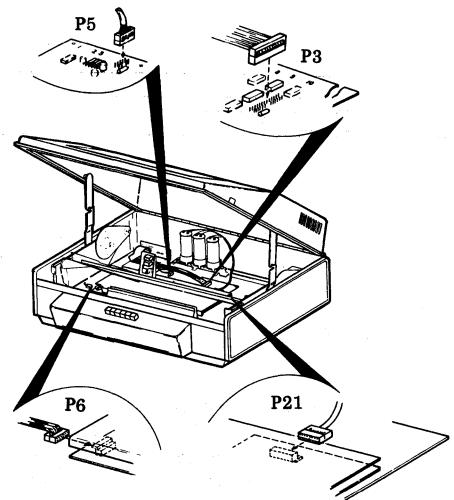

Fig. 15—P3, P5, P6 and P21 Connectors

Forms Access Printer

- (a) Loosen four screws securing controller cover to inside of forms access printer cabinet approximately two turns (Fig. 16).

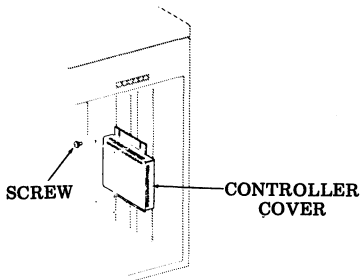

Fig. 16—Controller Removal

- (b) Slide controller cover up to limits of upper controller cover slots. Disengage controller cover from lower screws, slide cover down to disengage from upper screws.
- (c) Unplug connectors P3, P5, P6 and P21 (Fig. 17).

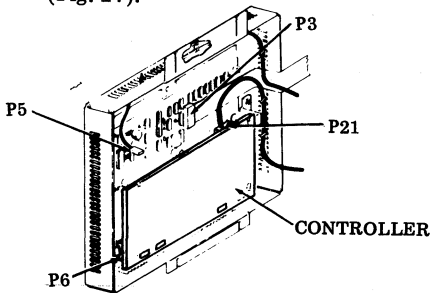

Fig. 17—Controller Connectors

- (d) Remove four screws securing the two brackets that hold the controller in place (Fig. 18).

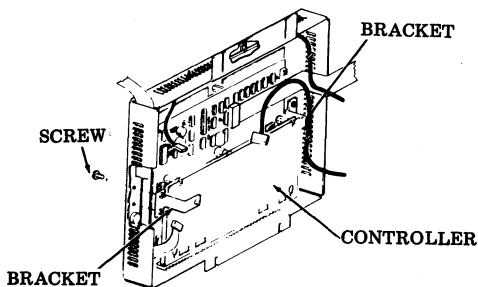

Fig. 18—Removal of Controller

- (e) Remove controller from controller cover.

4.04 To option the 410734 diode matrix circuit card (Fig. 20), the card must be separated from the 410733 controller card assembly.

4.05 To remove 410734 diode matrix circuit card:

Reminder: Ground yourself before handling the controller assembly, as discussed in 1.03.

- (a) Remove cover plate by loosening four screws (Fig. 19) and sliding cover to clear screws then lift off.

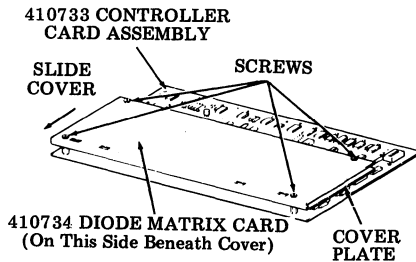

Fig. 19—40C303AC/003 Controller

(b) Remove two screws (loosened in (a)) securing the 410734 diode matrix card (see Fig. 19). Slide card outward until free of center posts. Fold card outward using connecting cable as hinge.

(c) Unplug connector from 410734 diode matrix card (Fig. 20).

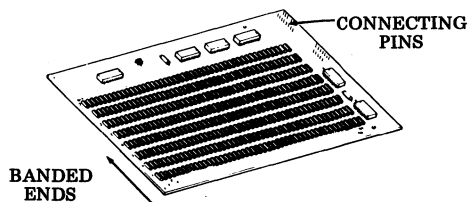

Fig. 20—410734 Diode Matrix Circuit Card

4.06 Printer option switches are accessible through cutouts in the bottom cover of the unit.

5. FIELD OPTIONS AND DESCRIPTIONS

5.01 Certain options are selected by setting miniature rocker/toggle switches on the 410071 or 410072 printer circuit card or on the 410733 circuit card of the 40C303AC/003 controller. Other options are implemented by cutting and removing diodes from the 410734 diode matrix circuit card of the controller.

5.02 Controller options are listed and briefly described on Pages 13 through 21. Options marked with an asterisk (*) are installed at the factory. Data set options are provided on Pages 59 through 63.

5.03 Options other than those shown as factory installed (*) may be specified for a particular installation. The Station Features and Option Record on the W-Plan should accurately reflect Service Center or field selection of options. Instructions for selecting and recording options are contained on Pages 22 through 58.

5.04 Numbers assigned to field options are used consistently in all field publications. Options should always be referred to by these numbers.

PRINTER OPTIONS

<u>OPTION NO.</u>	<u>DESCRIPTION</u>	<u>ACTION</u>
-------------------	--------------------	---------------

1 through 16 not present.

17. Printer Margin and Form Width

- | | |
|--------|----------------------------------|
| a.* | First Printed Column — Column 1 |
| b.2. | First Printed Column — Column 2 |
| b.3. | First Printed Column — Column 3 |
| b.4. | First Printed Column — Column 4 |
| b.5. | First Printed Column — Column 5 |
| b.6. | First Printed Column — Column 6 |
| b.7. | First Printed Column — Column 7 |
| b.8. | First Printed Column — Column 8 |
| b.9. | First Printed Column — Column 9 |
| b.10. | First Printed Column — Column 10 |
| b.11. | First Printed Column — Column 11 |
| b.12. | First Printed Column — Column 12 |
| b.13. | First Printed Column — Column 13 |
| c.* | Last Character on 80th Column |
| d.79. | Last Character on 79th Column |
| d.78. | Last Character on 78th Column |
| d.77. | Last Character on 77th Column |
| | etc. |
| d.25. | Last Character on 25th Column |
| e.* | Last Character on 132nd Column |
| f.131. | Last Character on 131st Column |
| f.130. | Last Character on 130th Column |
| f.129. | Last Character on 129th Column |
| | etc. |
| f.73. | Last Character on 73rd Column |

Choose a.

Choose c or e appropriate to printer ordered (80- or 132-column).

Note: Options c and d79 through d25 apply to 80-column printers only. Options e and f131 through f73 apply to 132-column printers only.

<u>OPTION NO.</u>	<u>DESCRIPTION</u>	<u>ACTION</u>
18.	<u>Printer Paper Feedout</u>	
a.	No Paper Feedout	} Choose a or b.
b.	Paper Feedout on Data Set Ready (CC) Loss — Up to 16 Lines or Form Feed	
c.*	Paper Feedout on Both Data Set Ready (CC) Loss and ETX — Up to 16 Lines or Form Feed	
<p><i>Note:</i> "Data Set Ready (CC) Loss" assumes that data set operation is used; the actual controlling SSI signal is loss of Receive Message. The feedout will be up to 16 lines only if Option 39.b.(Forms Switch off) is selected;if Option 39.a.(Forms Switch on) is selected, the printer will feed out paper to the next form feed position. Tractor feed printers using Option 39.b. should normally use Option 18.a. since the 16-line feedout will be shortened whenever end of form occurs before the 16 lines are up.</p>		
19.	<u>Printer Errored Character Symbol</u>	
a.*	Printed on Even Parity Error	} Choose a or c, Note 1.
b.	Printed on Odd Parity Error	
c.	Not Printed on Parity Error	} Choose one to match type carrier ordered.
d.	Printers With 96-Character Set	
e.	Printers With 64-Character Set	
f.	Printers With Extended ASCII Character Set	
g.	Printers With Longest Character Set Having Less Than 64 Characters	
<p><i>Note 1:</i> The integrated controller transmits even parity characters to the printer.</p> <p><i>Note 2:</i> Option switches for Options d, e and g must be set to reflect longest character set (f is for future use).</p>		
20.	<u>Line Feed on Printer</u>	
a.*	Single	} Choose one.
b.	Double	
<p><i>Note:</i> This option is operator-selectable.</p>		
21.	<u>Foldover on Up-Low Printer</u>	
a.*	Lower Case and Upper Case Print	} } Choose one to match type carrier ordered.
b.	Lower Case Prints as Upper Case	
22.	<u>Foldover on Monocase Printer</u>	
a.	Lower Case Prints as Error Symbol	} } Choose one to match type carrier ordered.
b.*	Lower Case Prints as Upper Case	

<u>OPTION NO.</u>	<u>DESCRIPTION</u>	<u>ACTION</u>
23.	<u>Extended ASCII on Printer (Extended ASCII)</u>	
a.	Prints Extended ASCII Characters (No Parity Checks)	} Choose b.
b.*	Does Not Print Extended ASCII Characters	
24. – 38.	Not Present	
39.	<u>Forms</u>	
a.	On	} Choose one.
b.*	Off	
<i>Note:</i> This option is operator-selectable.		
40. – 47.	Not Present	
48.	<u>Incomplete Form Suppresses Paper Alarm</u>	
a.	No (Paper-Out Not Gated With Form-Out)	} Choose one.
b.*	Yes (Paper-Out Gated With Form-Out)	
49. – 53.	Not Present	
54.	<u>Printing of Escape Sequences Suppressed</u>	
a.*	Character after ESC Printed as Received	} See Note.
b.	Printing of Character After ESC Suppressed	
<i>Note:</i> This option does not apply to the Integrated Synchronous ROP Terminal. Either option may be chosen without affecting operation.		
55.	<u>Shift-In/Shift-Out (SI/SO) Detection</u>	
a.*	SI/SO Detection Not Used	} See Note.
b.	SI/SO Detection Enables Printing Additional Characters	
<i>Note:</i> This option does not apply to the Integrated Synchronous ROP Terminal. Either option may be chosen without affecting operation.		
56.	Not Present	
57.	<u>SSI/OEM Interface</u>	
a.*	SSI	} Choose a.
b.	OEM	

<u>OPTION NO.</u>	<u>DESCRIPTION</u>	<u>ACTION</u>
58.	<u>Idle Line Motor Control</u>	
a.*	Disabled — Motor Held On Indefinitely During Idle Line	} Choose a.
b.	Enabled — Motor Turned Off After 40-Second Idle Line	
59.	Does not apply. This option does not affect the operations of the Integrated Synchronous ROP when Option 57.a. is chosen.	
60.	<u>Auxiliary Alarm</u>	
a.	Enable	} Choose b.
b.*	Disable	
<i>Note:</i> Future alarm mechanism. Select Option 60.b. when alarm mechanism is not present.		
61.	Regulator Grounding (Circuit Ground to Frame Ground)	
a.	SSI	} Choose c.
b.*	(OEM) at Printer	
c.	(OEM) External to Printer	

CONTROLLER OPTIONS

101.	Not applicable — see Options 189.a. and 190.a.	
102.—120.	Not Present	
121.	Left Margin Setting	Choose one; if b, specify left margin setting required by column number.
a.*	Left Margin at Column 1	} Choose one; if b, specify tab settings required by column numbers.
b.	Left Margin Begins at Any Column from 2 Up	
122.	Horizontal Tabulation Settings	
a.*	No Horizontal Tab Settings	} Choose one; if b, specify tab settings required by column numbers.
b.	Preprogrammed Tab Settings in Any Column From 1-80 (80-column printer) or 1-132 (132-column printer)	

Note: If compatibility with on-line tabs is required, the last setting on the line (column 80 or 132, depending on the printer selected) must be specified. This assures that a tab beyond the last enabled tab stop will cause the next character to be printed in the last column position and the character following that to be printed in the first character position of the next line (as selected by the left margin option, if used). (If the last setting on the line is not specified and a tab is received after the last tab stop, the next character received will be printed on the first character position of the next line).

<u>OPTION NO.</u>	<u>DESCRIPTION</u>	<u>ACTION</u>
123.	<u>Vertical Tabulation Settings</u>	
a.	No Vertical Tab Settings	} Choose one.
b.	Not Present	
c.	1st Vertical Tab Line (ESC A)	
d.	2nd Vertical Tab Line (ESC B)	
e.	3rd Vertical Tab Line (ESC C)	
f.	4th Vertical Tab Line (ESC D)	
g.	5th Vertical Tab Line (ESC E)	
h.	6th Vertical Tab Line (ESC F)	
i.	7th Vertical Tab Line (ESC G)	
j.	8th Vertical Tab Line (ESC H)	
k.	9th Vertical Tab Line (ESC I)	
l.	10th Vertical Tab Line (ESC J)	
m.	11th Vertical Tab Line (ESC K)	
n.	12th Vertical Tab Line (ESC L)	
	<i>Note:</i> Care must be taken not to select vertical tab settings which carry the printer beyond the form feed position. Option 20.b.(double line feed), if selected, will cause all vertical tab settings to be double those shown.	
124.	Not Present	
125.	<u>Type of Printer Used</u>	
a.*	80-Column Printer	} Choose one to match printer ordered.
b.	132-Column Printer	
126.—130.	Not Present	
131.	<u>Left Margin</u>	
a.*	Left Margin Begins at Column 1, Regardless of Programming of Options 121 and 122.	} Choose one.
b.	Left Margin Begins as Programmed in Option 121.	
	<i>Note:</i> b requires Option 17.c. or .e.	
132.—147.	Not Present	
148.	<u>Motor Turn Off Delay</u>	
a.*	Minimum Delay — Motor turns off approximately 30 seconds after buffer empties.	} Choose one.
b.	Maximum Delay — Motor turns off approximately 3 minutes after buffer empties.	
149.—158.	Not Present	

<u>OPTION NO.</u>	<u>DESCRIPTION</u>	<u>ACTION</u>
159.	<u>Variable Characters for System Operation</u>	
a.	Programmable Character 1 (Notes 1, 3, 4)	} Choose a character for each position except as noted (Notes 4, 5, 6, 7, 8 and 9).
b.	Programmable Character 2 (Notes 1, 2, 5)	
c.	Programmable Character 3 (Notes 2, 5, 6, 10)	
d.	Programmable Character 4 (Notes 2, 6, 10)	
e.	Programmable Character 5 (Note 7)	
f.	Programmable Character 6 (Notes 2, 8)	
g.	Programmable Character 7 (Notes 2, 9, 10)	
h.	DLE Character	
i.	ZERO Character	
j.	ONE Character	
k.	EOT Character	
l.	NAK Character	
m.	ENQ Character	
n.	Future Use	

Note 1: The characters encoded for Options 159.a. and .b. to represent the α characters (selections and replies) in Options 171.d. and .g. must be programmed using upper case letters. The equivalent letters when received in lower case will be recognized as part of the selection sequence. When used as upper case they will result in an EOT reply. Use of upper case characters is reserved for future use.

Note 2: Characters encoded for Options 159.b., .c., .d., .f., and g to represent the # or DC_n characters in Options 171.a., .c., .e., .g. and .h. must be programmed exactly as they will be received. Numeric characters may be used in addition to letters for device selection only.

Note 3: The character encoded for Option 159.a. to represent the α character in Option 171.c. must be programmed exactly as it will be received.

Note 4: Option 159.a. must be encoded if Option 171.c., .d., .e., .f., .g., or .h. and should be left uncoded if Option 171.a. or .b. is enabled.

Note 5: Option 159.b. must be encoded if Option 171.c., .d., .e., .f., .g., or .h. is enabled. Option 159.b. should be left uncoded if Option 171.a. or .b. is enabled. Option 159.b. is normally coded the same as Option 159.a. when Option 171.d., .e., .f., .g. or .h. is enabled.

Note 6: Options 159.c. and .d. may be left uncoded if Option 171.c. is enabled and must be left uncoded if 171.a., .b., .d., .e., .f. or .g. is enabled. They must be encoded if Option 171.h. is enabled.

Note 7: Option 159.e. must be encoded if Option 171.h. is enabled and uncoded if Option 171.a., .b., .c., .d., .e., .f. or .g. is enabled.

Note 8: Option 159.f. must be encoded for Option 171.a., .e., .g. and .h.. It must be uncoded when Option 171.b., .c., .d. or .f. is enabled.

Note 9: Option 159.g. is for future use. It may be encoded for Option 171.a., .e., .g. and .h. It must be uncoded when Option 171.b., .c., .e. or .f. is enabled.

Note 10: If characters that may be left uncoded are encoded, per Notes 6 and 9, a character must be chosen that is not used in other selection control functions of the system.

Note 11: Commonly used characters:

	ASCII	EBCDIC
159.h.	DLE (Hex 10)	DLE (Hex 10)
159.i.	0 (Hex 30)	0 (Hex 70)
159.j.	1 (Hex 31)	/ (Hex 61)
159.k.	EOT (Hex 04)	EOT (Hex 37)
159.l.	NAK (Hex 15)	NAK (Hex 3D)
159.m.	ENQ (Hex 05)	ENQ (Hex 2D)

Note 12: Application table for characters 159.a. through 159.g.

The table shows the application of each of the programmable characters of Opt. 159a-g to the related Option 171a-h. Note that some characters may be optionally coded. For these, choose a character which is **not used** in any other poll/select/control functions of the system.

Option 171 – SELECTION FORMATS								
	a	b	c	d	e	f	g	h
159a- Programmable Character 1 (PC1)			PC1=A _{U/L} =α ₁	PC1=A _U =α ₁	PC1=A _{U/L} =α ₁	PC=A _{U/L} =α ₁	PC1=A _U =α ₁	PC1=A _{U/L} =α ₁
159b- Programmable Character 2 (PC2)			PC2=DC1=#	PC2=A _U =α ₂	PC2=A _{U/L} =α ₂	PC2=A _{U/L} =α ₂	PC2=A _U =α ₂	PC2=A _{U/L} =α ₂
159c- Programmable Character 3 (PC3)			PC3=# NOTE 14					PC3=A _{U/L} =A ₂
159d- Programmable Character 4 (PC4)			PC4=# NOTE 14					PC4=A _{U/L} =B ₂
159e- Programmable Character 5 (PC5)								PC5=A _{U/L} =C ₂
159f- Programmable Character 6 (PC6)	PC6=DC1=DC _n NOTE 16				PC6=DC1=DC _n NOTE 16		PC6=DC1=#	PC6=DC1=DC _n NOTE 16
159g Programmable Character 7 (PC7)	PC7=A _{U/L} NOTE 15				PC7=A _{U/L} NOTE 15		PC7=A _{U/L} NOTE 13	PC7=A _{U/L} NOTE 15

LEGEND



Must be left uncoded.



Normally left uncoded or may be optionally encoded as indicated.

PC (N) Programmable character (number), e.g. PC1.

A_U Upper Case Alphabetic Character Only

A_{U/L} Upper or Lower case Alphabetic Character

DC₁ Most host systems use DC₁ for printer selection. Other characters may be assigned.

- Note 13: Option 159.g. is intended for future use. A code sequence corresponding to 159.g. will result in a NAK response.
- Note 14: If sequences corresponding to 159.c. or 159.d. are received a NAK or EOT reply will be generated respectively.
- Note 15: Option 159.g. is intended for future use. An EOT reply will be generated for a 159.g. sequence.
- Note 16: If DC_n is not transmitted the terminal will assume that selection of the printer was intended.

<u>OPTION NO.</u>	<u>DESCRIPTION</u>	<u>ACTION</u>
160.	<u>Communication Code — Line Operation</u>	
a.*	ASCII	} Choose one.
b.	EBCDIC	
161.	<u>Future Use</u>	
a.*	All Present Applications	} Choose a.
b.	Possible Future Use	
162.	<u>Type Font Length</u>	
a.*	Normal (64 or 96 Characters)	} Choose one.
b.	Short (48 Characters)	
163.	<u>Future Use</u>	
a.*	All Present Applications	} Choose a.
b.	Possible Future Use	
164.	<u>Block Size</u>	
a.	128 Characters	} Choose one.
b.	256 Characters	
c.*	512 Characters	
165.	<u>Future Use</u>	
a.*	All Present Applications	} Choose a.
b.	Possible Future Use	
166.	<u>Data Carrier Disconnect</u>	
a.*	Terminal will disconnect if data carrier is lost for 30 seconds or if there is no carrier within 30 seconds after a call connection.	} Choose one.
b.	There is no disconnect due to absence of carrier.	
167.	<u>Permanent Request-to-Send</u>	
a.*	RTS On Only when Required for Transmission	} Choose one.
b.	RTS On at All Times that Data Terminal Ready is On	
<i>Note:</i> Data Terminal Ready is Off when in the TEST mode or there is a Terminal Alarm condition.		
168.	<u>Future Use</u>	
a.*	All Present Applications	} Choose a.
b.	Possible Future Use	
169.	<u>Future Use</u>	
a.*	All Present Applications	} Choose a.
b.	Possible Future Use	

OPTION NO.	DESCRIPTION	ACTION
170.	<u>Space Extension</u>	
a.*	Space Character Results in Single Space on Printer	} Choose one.
b.	Space Character Results in Three Spaces on Printer	
171.	<u>Selection Formats (PAD and SYN Characters Omitted)</u>	
a.	Point-to-Point Private Line/Switched-Network Without Terminal Identification Providing Device Selection	} Choose one. (Also see next page)
	$ \begin{array}{l} E \begin{bmatrix} A \\ C \emptyset \\ K \end{bmatrix} \begin{array}{l} S \\ T \\ X \end{array} \begin{array}{l} D \\ C \\ n \end{array} \\ N \\ Q \end{array} $ Notes: 1, 2, 3, 4 and 5	
b.	Point-to-Point Private Line/Switched-Network Without Terminal Identification or Device Selection	
	$ \begin{array}{l} E \begin{bmatrix} A \\ C \emptyset \\ K \end{bmatrix} \begin{array}{l} S \\ T \\ X \end{array} \\ N \\ Q \end{array} $ Notes: 2, 3 and 4	
c.	Multipoint Private Line Providing Device Selection	
$\alpha \#$	$ \begin{array}{l} E \begin{bmatrix} A \\ C \emptyset \\ K \end{bmatrix} \begin{array}{l} S \\ T \\ X \end{array} \\ N \\ Q \end{array} $ Notes: 1, 2, 3, 4 and 7	
d.	Multipoint Private Line Without Device Selection	
$\alpha 1 \alpha 2$	$ \begin{array}{l} E \begin{bmatrix} \alpha_1 \alpha_2 A \\ C \emptyset \\ K \end{bmatrix} \begin{array}{l} S \\ T \\ X \end{array} \\ N \\ Q \end{array} $ Notes: 2, 3, 4, 6 and 11	
e.	Switched-Network With Terminal Identification Providing Device Selection	
$\alpha A \alpha B$	$ \begin{array}{l} E \begin{bmatrix} \alpha_1 \alpha_2 A \\ C \emptyset \\ K \end{bmatrix} \begin{array}{l} S \\ T \\ X \end{array} \begin{array}{l} D \\ C \\ n \end{array} \\ N \\ Q \end{array} $ Notes: 1, 2, 3, 4, 5, and 10	
f.	Switched-Network With Terminal Identification Without Device Selection	
$\alpha A \alpha B$	$ \begin{array}{l} E \begin{bmatrix} \alpha_1 \alpha_2 A \\ C \emptyset \\ K \end{bmatrix} \begin{array}{l} S \\ T \\ X \end{array} \\ N \\ Q \end{array} $ Notes: 2, 3, 4 and 10	
g.	Multipoint Private Line With Device Selection	
$\alpha 1 \alpha 2 \#$	$ \begin{array}{l} E \begin{bmatrix} A \\ C \emptyset \\ K \end{bmatrix} \begin{array}{l} S \\ T \\ X \end{array} \\ N \\ Q \end{array} $ Notes: 1, 2, 3, 4, 6, and 8	

OPTION NO.	DESCRIPTION	ACTION
h.	Switched Network Providing Device Selection and Security Identification	Continued from previous page.
	$\alpha_A \alpha_B A_1 B_1 C_1 \overset{E}{N} \left[\alpha_1 \alpha_2 A_2 B_2 C_2 \overset{A}{C} \overset{\emptyset}{K} \right] \overset{S}{T} \overset{D}{C} \overset{X}{n}$	Notes: 1, 2, 3, 4, 5, and 9

Note 1: Device selection is restricted to the printer only at this time.

Note 2: The character code for ENQ is programmable. See Option 159.m.

Note 3: The [] represents Ready to Receive (ACK \emptyset)/Not Ready to Receive (NAK) replies from the ROP terminal. An ACK \emptyset reply is required for the sequence to continue. ACK \emptyset is preceded by $\alpha_1 \alpha_2$ in Options 171.d., e., f. and h..

Note 4: The sequence starting with STX (optionally SOH) is sent as the initial characters of the first block of a message. In Formats 171.a., e., and h. STX (optionally SOH) is also part of the selection sequence.

Note 5: DC_n must be coded using Option 159.f. The use of Option 159.g. to code DC_n is reserved for future applications and may be left uncoded; however, if Option 159.g. is coded (due to system compatibility) the terminal on receiving a selection sequence containing the character coded by Option 159.g. will respond with an EOT. If the selection sequence fails to include DC_n the terminal will assume that the printer is being addressed. Normally the characters encoded for DC_n are chosen from the DC₁ through DC₄ category.

Note 6: The $\alpha_1 \alpha_2$ are coded using Options 159.a. and 159.b. They represent the station identity. Normally Option 159.b. is coded identically to Option 159.a.

Note 7: The α in Option 171.c. is the station identity and is coded using Option 159.a. The # is the device select character and is coded using Option 159.b. The use of Options 159.c. or 159.d. is reserved for future applications and may be left uncoded; however, if Option 159.c. or 159.d. are coded (due to system compatibility) the terminal on receiving a selection sequence containing the characters coded by Options 159.c. or 159.d. will respond with a NAK (for 159.c.) or an EOT (for 159.d.).

Note 8: # must be coded using Option 159.f. The use of Option 159.g. to code # is reserved for future applications and it may be left uncoded; however, if Option 159.g. is coded for system compatibility, the terminal on receiving a selection sequence containing the character coded by Option 159.g. will respond with a NAK.

Note 9: $\alpha_A \alpha_B A_1 B_1 C_1$ are the LCU station identification characters and are not checked. The reply is $\alpha_1 \alpha_2 A_2 B_2 C_2$ followed by ACK \emptyset or NAK. $\alpha_1 \alpha_2 A_2 B_2 C_2$ are part of []. (See Note 3.) $\alpha_1 \alpha_2$ in the reply identifies the ROP terminal. $A_2 B_2 C_2$ represents a security identification sequence encoded by Options 159.c., 159.d., and 159.e. See Note 6 for coding of $\alpha_1 \alpha_2$.

Note 10: $\alpha_A \alpha_B$ are the LCU station identification characters and are not checked. The reply is $\alpha_1 \alpha_2$ followed by the terminal status. $\alpha_1 \alpha_2$ are part of []. (See Note 3.) See Note 6 for coding of $\alpha_1 \alpha_2$.

Note 11: ACK \emptyset reply is preceded by $\alpha_1 \alpha_2$. $\alpha_1 \alpha_2$ are part of []. (See Note 3.) The $\alpha_1 \alpha_2$ in the reply identifies the ROP terminal. See Note 6 for coding of $\alpha_1 \alpha_2$.

<u>OPTION NO.</u>	<u>DESCRIPTION</u>	<u>ACTION</u>
172.	<u>Future Use</u>	
a.*	All Present Applications	} Choose a.
b.	Possible Future Use	
173.	<u>ETB</u>	
a.*	Block terminator	} Choose one.
b.	Block terminator, executes printing a line, executes vertical tab ESC sequence (or NEW LINE if none) or terminates horizontal tab setting sequence.	
174.	<u>ETX</u>	
a.*	Block terminator or terminates horizontal tab setting sequence	} Choose one.
b.	Block terminator, terminates horizontal tab setting sequence, executes printing a line or executes vertical tab ESC sequence (or NEW LINE if none).	
175.	<u>ITB</u>	
a.*	Intermediate block terminator	} Choose one.
b.	Block terminator, executes printing a line, executes vertical tab ESC sequence (or NEW LINE if none) or terminates horizontal tab setting sequence.	
176.	<u>LINE FEED/NEW LINE</u>	
a.*	Executes printing a line, executes vertical tab ESC sequence (or NEW LINE if none) or terminates horizontal tab setting sequence.	} Choose one.
b.	SPACE only	
177.	<u>RS or IRS (EBCDIC)</u>	
a.*	Executes printing a line and executes vertical tab ESC sequence (or NEW LINE if none)	} Choose one.
b.	SPACE only	
178.	<u>Immediate WACK</u>	
a.*	Disabled	} Choose one.
b.	Enabled	
179.	<u>WACK/BUFFER Control</u>	
a.*	WACK response enabled, multiple block buffer.	} Choose one.
b.	WACK response disabled, single block buffer.	

<u>OPTION NO.</u>	<u>DESCRIPTION</u>	<u>ACTION</u>
180.--188.	<u>Future Use</u>	
a.*	All Present Applications	} Choose a.
b.	Possible Future Use	
189.	<u>Receiver Clock Control</u>	
a.*	Receiver Clock Obtained From Associated Data Set	} Choose a.
b.	Receiver Clock Generated Internally	
190.	<u>Transmitter Clock Control</u>	
a.*	Transmitter Clock Obtained From Associated Data Set	} Choose a.
b.	Transmitter Clock Generated Internally	

GROUND OPTION

<u>OPTION NO.</u>	<u>DESCRIPTION</u>	<u>ACTION</u>
	<u>Ground Connection</u>	
a.*	Frame Ground Connected to Signal Ground	} Choose one.
b.	Frame Ground Not Connected to Signal Ground	

Note: A connection between frame ground and signal ground is required for proper operation of the internal test message. Most data sets make this connection either permanently or as an option, but a few do not. If a cable longer than the standard (408065) is used to connect the data set to the ROP, it may be necessary to break this connection at either the controller or the data set (but not both) to avoid electrical noise problems (caused by a ground loop).

6. OPTION ACTIVATION

6.01 Connect the static discharge strap to wrist as described in 1.03 before activating the options on 410071 or 410072 printer card.

6.02 The format for showing options (except data set options) is illustrated in Fig. 21.

OPTION NO.	OPTION CONDITIONS	OPTION DEFINITION	SWITCH DESIGNATION ON CIRCUIT CARD					
			TOGGLE, SLIDE, OR ROCKER SWITCH NUMBERS					
			A-10					
5.			1	2	3	4	5	
a.			●	-	-	-	-	*
b.			○	-	-	-	-	
c.			-	●	-	-	-	*
d.			-	○	-	-	-	
e.			-	-	○	-	-	*
f.			-	-	●	-	-	

- Indicates dot end of rocker switch depressed, toggle or slide positioned to ON.
- Indicates blank end of rocker switch depressed, toggle or slide positioned to OFF.
- Switch position does not affect option.
- * Factory installed.

Fig. 21—Option Information Format

6.03 Several styles of option selecting switches may be present on the printer and/or controller circuit cards (Fig. 22). The option selecting switches are of various sizes, having between four and ten toggles, slides or rockers, numbered accordingly. On toggle or slide type switches, options are activated by positioning the toggle or slide toward the ON designation. On rocker type switches, the dotted rocker end or the rocker end adjacent to a dot are positioned down (depressed) to activate an option. Conversely, to deactivate or switch OFF an option, position the toggle or slide away from ON or depress the blank end of the rocker switch.

Note: Switch covers are supplied in a bag for rocker type option switches only. Install covers after implementing options to prevent accidental change of switch position. Part numbers are as follows:

- | | |
|--------------------------|--------------------------|
| four positions — 341844 | eight positions — 341848 |
| five positions — 341845 | nine positions — 341849 |
| six positions — 341846 | ten positions — 341850 |
| seven positions — 341847 | |

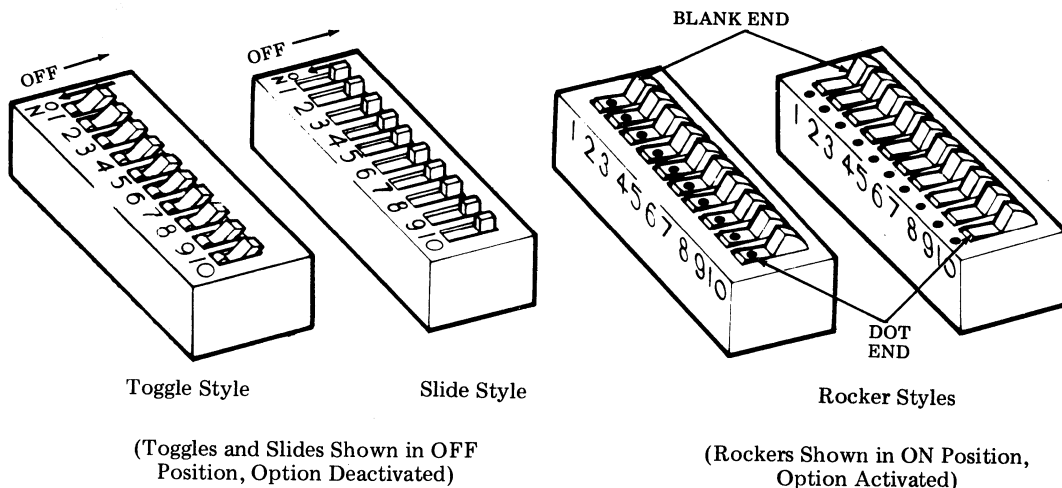
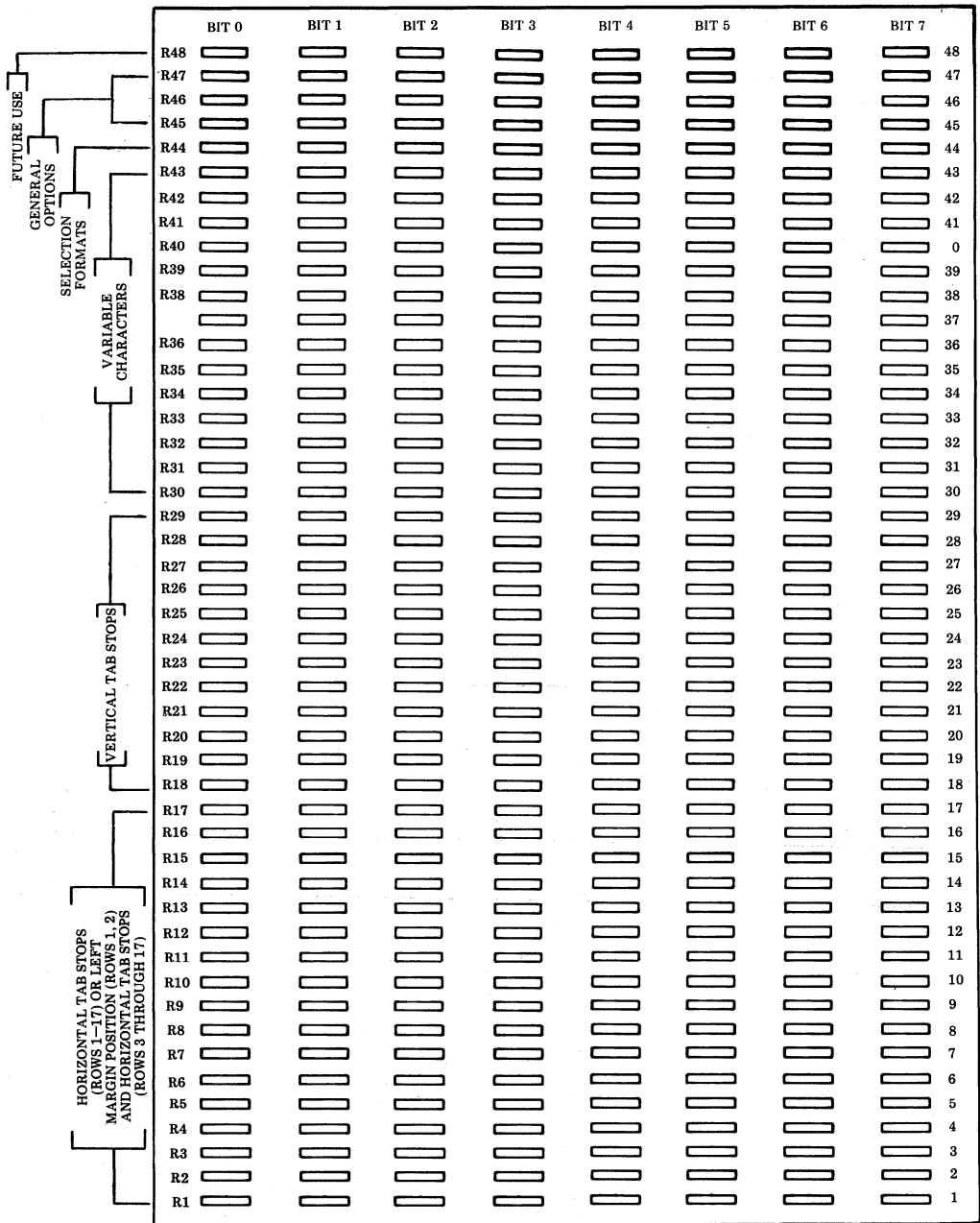

Fig. 22—Option Switches

6.04 The 410734 diode matrix circuit card is composed of several integrated circuit (IC) packs and 384 407336 diodes arranged in eight columns (bit 0 through bit 7) of 48 diodes each (see Fig. 22). The horizontal rows are designated R1 through R48 and the vertical columns are designated b0 through b7 in all subsequent optioning instructions of this section. Optioning consists of referring to the Station Feature and Option Record on W-Plan W-4RPXA and the service order and cutting and removing those diodes marked X.

Warning: Diodes should be marked (felt tip pen) before cutting to guard against mistakes. Diodes cut in error CANNOT be resoldered in place - the diode must be replaced, using care not to overheat when soldering. Make certain diode is oriented correctly, the same as the other diodes on the card (banded end toward IC packs --- Fig. 20). RECHECK BEFORE CUTTING!



⎓ Diode left in.

Fig. 23—410734 Diode Matrix Circuit Card Layout

6.05 Examples of Option Selecting on 410734 Diode Matrix Circuit Card

Example 1: Rows R1 through R17 (Fig. 24):

Note: Diodes at R17, b4, b5, b6 and b7 are not used.

(a) Each diode represents one horizontal space or column on the printer, ranging from columns 1, 2 and 3 for R1, b0, b1, b2 in order to columns 130, 131 and 132 for R17, b1, b2 and b3. With all diodes in place the printer left margin is at column 1 and no preset horizontal tab stops are provided. Cutting the appropriate

diode(s) establishes a printer left margin in other than column 1 and provides tab stops for wherever desired on a line, PROVIDED Option 131 is also activated. In addition, the diode representing the right-hand margin as selected by Option 17.c. or 17.e., must be removed. Obviously tab stop settings to the left of the left margin, or to the right of the right margin will not be optioned.

(b) The example (Fig. 24) represents diode optioning to have a 132-column tractor printer left margin at column 3, with tab stops at columns 20, 40, 60, 80, 100 and 120. See Options 17. and 131.

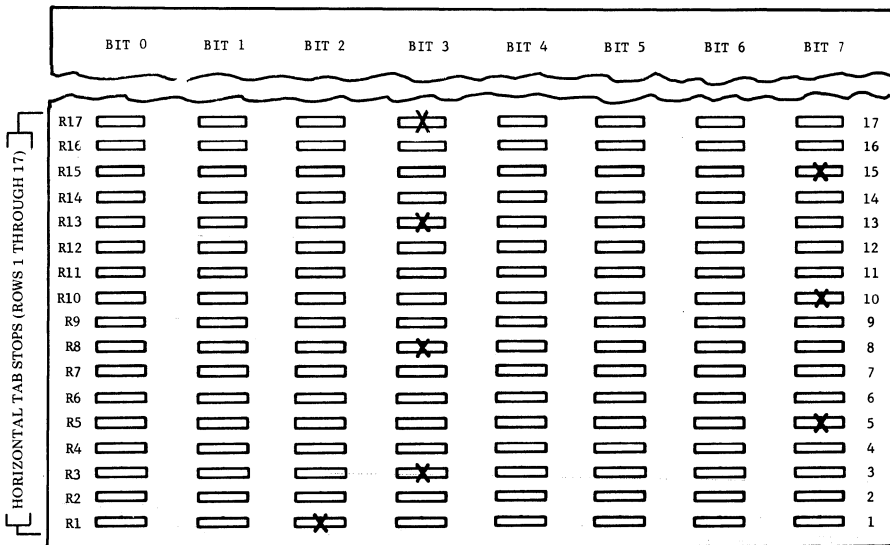

□ Diode left in.
 ✗ Diode cut and removed.

Fig. 24—Example 1: 410734 Diode Matrix Circuit Card Optioning

Example 2: Rows R18 through R29 (Fig. 25):

(a) Each row of diodes represents one vertical tab stop in increasing number from Row 18 for the first tab stop to R29 for the twelfth tab stop. Selections must be made in increasing number. When less than 12 tab stops are used the unused positions (starting with the twelfth tab stop position) must have all diodes left in.

Bit 1 = 2, Bit 2 = 4, Bit 3 = 8, Bit 4 = 16, Bit 5 = 32, Bit 6 = 64 and Bit 7 = 128) to get the line count as indicated below:

For a tab stop at line 5 diodes at the Bit 0 and Bit 2 positions are removed; for a tab stop at line 26 diodes the Bit 1, Bit 3 and Bit 4 positions are removed.

(b) The line number desired is encoded by removing diodes. The binary count of the removed diodes is added together (Bit 0 = 1,

(c) The example (Fig. 25) represents diode optioning for vertical tab stops at 5, 10, 30, 40, 55 and 70 lines from the start of form.

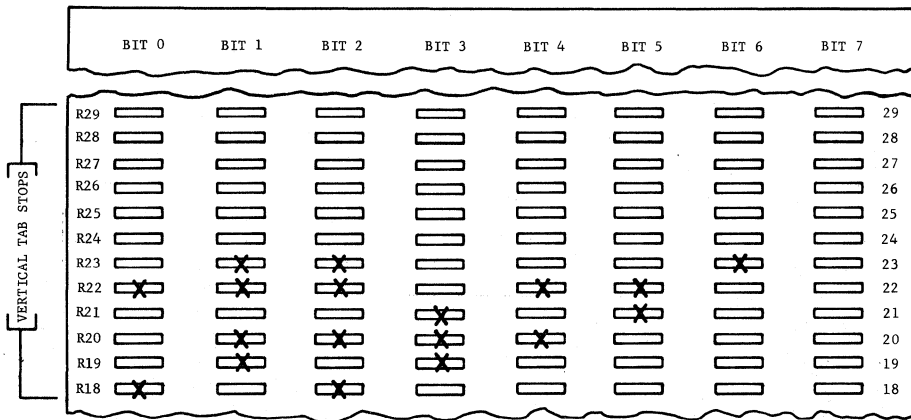

□ Diode left in.
 ⊗ Diode cut and removed.

Fig. 25—Example 2: 410734 Diode Matrix Circuit Card

Example 3: Rows R30 through R43 (Fig. 26):

Each row of R30 through R43 is used to represent a variable character for system operation (Option 159). Diodes left in place (◻) represent spacing bits; diodes removed (✕) represent marking bits. If ASCII characters are used, information bits 1 through 7 are encoded by diodes Bit 0 through Bit 6. The diode in location Bit 7 must be used to provide odd parity for the character. If EBCDIC characters are used, information bits 7 through 0 are encoded by diodes Bit 0 through Bit 7.

In the example, selection format 171.a, (Point-to-Point Private Line) is assumed.

- Rows 39 through 43 — Variable characters 159. a. through e. are uncoded.
- Row 38 — Variable character 159.f. is coded for DCn: ASCII character DC₁; EBCDIC character DC1
- Row 37 — Variable character 159.g. is uncoded.
- Row 36 — Variable character 159.h. is coded for DLE: ASCII character DLE; EBCDIC character DLE
- Row 35 — Variable character 159.i. is coded for ZERO: ASCII character ZERO; EBCDIC character Hex 70
- Row 34 — Variable character 159.j. is coded for ONE: ASCII character ONE; EBCDIC character /
- Row 33 — Variable character 159.k. is coded for EOT: ASCII character EOT; EBCDIC character EOT
- Row 32 — Variable character 159.l. is coded for NAK: ASCII character NAK; EBCDIC character NAK
- Row 31 — Variable character 159.m. is coded for ENQ: ASCII character ENQ; EBCDIC character ENQ
- Row 30 — Variable character 159.n. is uncoded.

ASCII Version

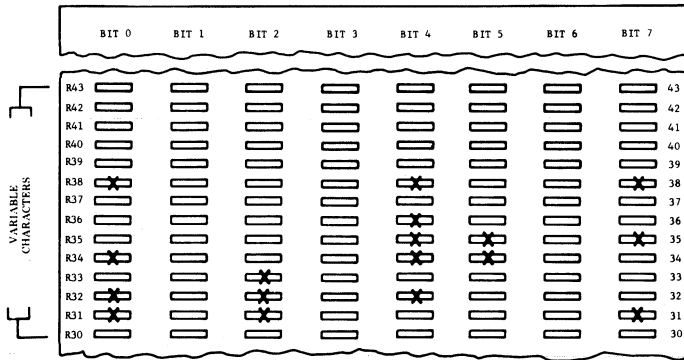

EBCDIC Version

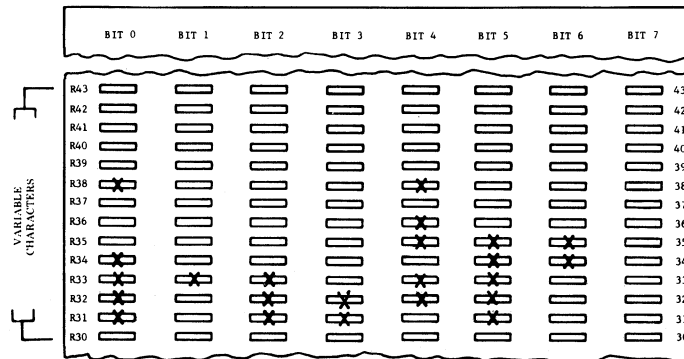

Fig. 26—Example 3: 410734 Diode Matrix Circuit Card Optioning

- ◻ Diode left in.
- ✕ Diode cut and removed.

Example 4: Rows R44 through R48 (Fig. 27):

- (a) Row 44 diodes Bit 0 through Bit 7 relate to system protocol and format selections (Option 171). Option 171a (Point-to-Point Private Line) format is illustrated in Fig. 26.
- (b) Each diode in Rows 45, 46, and 47 represents a specific selectable feature or is reserved for future use:

<u>OPTION NUMBER</u>	<u>RELATED DIODE LOCATION</u>	<u>OPTION NUMBER</u>	<u>RELATED DIODE LOCATION</u>
125.	R46, BIT 6	170.	R45, BIT 7
131.	R46, BIT 4	173.	R47, BIT 0
148.	R46, BIT 5	174.	R47, BIT 1
160.	R46, BIT 0	175.	R47, BIT 2
162.	R46, BIT 2	176.	R47, BIT 3
164.	R45, BIT 0, BIT 1	177.	R47, BIT 4
166.	R45, BIT 3	178.	R47, BIT 5
167.	R45, BIT 4	179.	R47, BIT 6

The following option numbers and diode locations are reserved for future applications:

<u>OPTION NUMBER</u>	<u>RELATED DIODE LOCATION</u>	<u>OPTION NUMBER</u>	<u>RELATED DIODE LOCATION</u>
161.	R46, BIT 1	168.	R45, BIT 5
163.	R46, BIT 3	169.	R45, BIT 6
165.	R45, BIT 2	172.	R46, BIT 7
		180.	R47, BIT 7

For option titles and descriptions refer to Part 5. FIELD OPTIONS AND DESCRIPTIONS. Refer to ACTIVATING CONTROLLER OPTIONS for activation of specific options.

- (c) Diodes in Row 48 reserved for future applications.

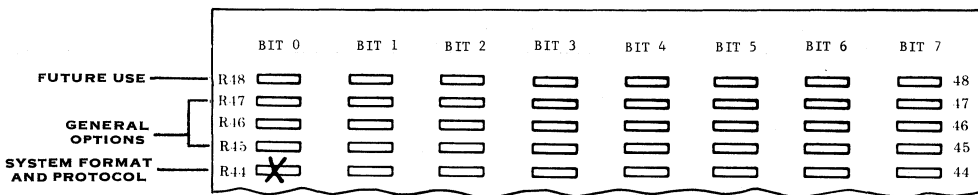

Diode left in.
 Diode cut and removed.

Fig. 27—410734 Diode Matrix Circuit Card

TABLE A
ASCII CODE SET

TRANSMITTING CODES

		0				1				Bits 7		
		0		1		0		1		Bits 6		
Bits	Hex 1	0	1	0	1	0	1	0	1	Bits 5		
4	3	2	1	0	1	2	3	4	5	6	7	Hex 0
0	0	0	0	NUL	DLE	SP	0	@	P	`	p	
		1	1	SOH	DC1	!	1	A	Q	a	q	
		0	2	STX	DC2	"	2	B	R	b	r	
		1	3	ETX	DC3	*	3	C	S	c	s	
	1	0	4	EOT	DC4	\$	4	D	T	d	t	
		1	5	ENQ	NAK	%	5	E	U	e	u	
		0	6	ACK	SYN	&	6	F	V	f	v	
		1	7	BEL	ETB	'	7	G	W	g	w	
1	0	0	8	BS	CAN	(8	H	X	h	x	
		1	9	HT	EM)	9	I	Y	i	y	
		0	A	NL	SUB	*	:	J	Z	j	z	
		1	B	VT	ESC	+	;	K	[k	{	
	1	0	C	FF	FS	,	<	L	\	l	!	
		1	D	CR	GS	-	=	M]	m	}	
		0	E	SO	RS	.	>	N	^	n	~	
		1	F	SI	US	/	?	O	_	o	DEL	

Note: 1 = Mark 0 = Space
Example: Bits 1 through 7 of the bit permutation for the character M are 1011001, respectively.

- | | |
|---------------------------|---------------------------------|
| NUL — Null | DC1 — Device Control 1 |
| SOH — Start of Heading | DC2 — Device Control 2 |
| STX — Start of Text | DC3 — Device Control 3 |
| ETX — End of Text | DC4 — Device Control 4 |
| EOT — End of Transmission | NAK — Negative Acknowledge |
| ENQ — Enquiry | SYN — Synchronous |
| ACK — Acknowledge | ETB — End of Transmission Block |
| BEL — Bell | CAN — Cancel |
| BS — Back Space | EM — End of Media |
| HT — Horizontal Tab | SUB — Substitute |
| NL — New Line | ESC — Escape |
| VT — Vertical Tab | FS — Field Separator |
| FF — Form Feed | GS — Group Separator |
| CR — Carriage Return | RS — Record Separator |
| SO — Shift-Out | US — Unit Separator |
| SI — Shift-In | SP — Space |
| DLE — Data Link Escape | DEL — Delete |

TABLE B
EBCDIC CODE SET

Bits 4567	Hex 1	00				01				10				11				Bits 01
		00	01	10	11	00	01	10	11	00	01	10	11	00	01	10	11	Bits 23
		0	1	2	3	4	5	6	7	8	9	A	B	C	D	E	F	Hex 0
0000	0	NUL	DLE	DS		SP	&	-							[]	\	0
0001	1	SOH	DC1	SOS			/			a	j	~			A	J		1
0010	2	STX	DC2	FS	SYN					b	k	s			B	K	S	2
0011	3	ETX	DC3							c	l	t			C	L	T	3
0100	4	PF	RES	BYP	PN					d	m	u			D	M	U	4
0101	5	HT	NL	LF	RS					e	n	v			E	N	V	5
0110	6	LC	BS	ETB	UC					f	o	w			F	O	W	6
0111	7	DEL	IL	ESC	EOT					g	p	x			G	P	X	7
1000	8	GE	CAN							h	q	y			H	Q	Y	8
1001	9	RLF	EM							i	r	z			I	R	Z	9
1010	A	SMM	CC	SM		¢	!		:									LVM
1011	B	VT	CUI	CU2	CU3	.	\$,	#									
1100	C	FF	IFS		DC4	<	*	%	@									
1101	D	CR	IGS	ENQ	NAK	()	_	'									
1110	E	SO	IRS	ACK		+	;	>	=									
1111	F	SI	IUS	BEL	SUB		¬	?	”									EO

Note 1: All blanks will be printed with an error symbol.

Note 2: Hex 0 represents bits 0, 1, 2, 3; Hex 1 represents bit 4, 5, 6, 7. Example: Hex D4 is the character “M”.

Note 3: 1 = Mark 0 = Space

Example: Bits 7 through 0 of the bit permutation for the character M are 00101011, respectively.

- | | | |
|-------------------------------|------------------------------------|----------------------------|
| NUL — NULL | DC3 — Device Control 3 | ESC — Escape |
| SOH — Start of Heading | RES — Restore | SM — Set Mode |
| STX — Start of Text | NL — New Line | CU2 — Customer User 2 |
| ETX — End of Text | BS — Back Space | ENQ — Enquire |
| PF — Punch Off | IL — Idle | ACK — Acknowledge |
| HT — Horizontal Tab | CAN — Cancel | BEL — Bell |
| LC — Lower Case | EM — End of Media | SYN — Synchronous |
| DEL — Delete | CC — Cursor Control | PN — Punch On |
| GE — Graphics Escape | CUI — Customer User 1 | RS — Reader Stop |
| RLF — Reverse Line Feed | IFS — Interchange Field Separator | UC — Upper Case |
| SMM — Start of Manual Message | IGS — Interchange Group Separator | EOT — End of Transmission |
| VT — Vertical Tab | IRS — Interchange Record Separator | CU3 — Customer User 3 |
| FF — Form Feed | IUS — Interchange Unit Separator | DC4 — Device Control 4 |
| CR — Carriage Return | DS — Digit Select | NAK — Negative Acknowledge |
| SO — Shift-Out | SOS — Start of Significance | SUB — Substitute |
| SI — Shift-In | FS — Field Separator | SP — Space |
| DLE — Data Link Escape | BYP — By Pass | LVM — Long Vertical Mark |
| DC1 — Device Control 1 | LF — Line Feed | EO — Eight Ones |
| DC2 — Device Control 2 | ETB — End of Transmission Block | |

TABLE C
48-CHARACTER ASCII CODE SET

		0				1				Bits 7			
		0		1		0		1		Bits 6			
Bits	Hex 1	0	1	0	1	0	1	0	1	Bits 5			
4	3	2	1	0	1	2	3	4	5	6	7	Hex 0	
0	0	0	0	NUL	DLE	SP	0	@	P	@	P		
		1	1	SOH	DC1		1	A	Q	A	Q		
		0	2	STX	DC2		2	B	R	B	R		
		1	3	ETX	DC3	*	3	C	S	C	S		
	1	0	0	4	EOT	DC4	\$	4	D	T	D	T	
		1	5	ENQ	NAK	%	5	E	U	E	U		
		0	6	ACK	SYN	&	6	F	V	F	V		
		1	7	BEL	ETB		7	G	W	G	W		
	1	0	0	8	BS	CAN		8	H	X	H	X	
			1	9	HT	EM		9	I	Y	I	Y	
			0	A	NL	SUB	*		J	Z	J	Z	
			1	B	VT	ESC			K		K		
1		0	C	FF	FS	,	☐	L		L			
		1	D	CR	GS	-		M		M			
		0	E	SO	RS	.		N		N			
		1	F	SI	US	/		O		O			

Note 1: All blanks will be printed with an error symbol.

Note 2: 1 = Mark 0 = Space

Example: Bits 1 through 7 of the bit permutation for the character M are 1011001, respectively.

NUL — Null	DLE — Data Link Escape
SOH — Start of Heading	DC1 — Device Control 1
STX — Start of Text	DC2 — Device Control 2
ETX — End of Text	DC3 — Device Control 3
EOT — End of Transmission	DC4 — Device Control 4
ENQ — Enquiry	NAK — Negative Acknowledge
ACK — Acknowledge	SYN — Synchronous
BEL — Bell	ETB — End of Transmission Block
BS — Back Space	CAN — Cancel
HT — Horizontal Tab	EM — End of Media
NL — New Line	SUB — Substitute
VT — Vertical Tab	ESC — Escape
FF — Form Feed	FS — Field Separator
CR — Carriage Return	GS — Group Separator
SO — Shift-Out	RS — Record Separator
SI — Shift-In	US — Unit Separator

TABLE D

48-CHARACTER EBCDIC CODE SET

Bits 4567	Hex 1	00				01				10				11				Bits 01
		00	01	10	11	00	01	10	11	00	01	10	11	00	01	10	11	Bits 23
		0	1	2	3	4	5	6	7	8	9	A	B	C	D	E	F	Hex 0
0000	0	NUL	DLE	DS		SP	&	-									0	
0001	1	SOH	DC1	SOS			/			A	J			A	J		1	
0010	2	STX	DC2	FS	SYN					B	K	S		B	K	S	2	
0011	3	ETX	DC3							C	L	T		C	L	T	3	
0100	4	PF	RES	BYP	PN					D	M	U		D	M	U	4	
0101	5	HT	NL	LF	RS					E	N	V		E	N	V	5	
0110	6	LC	BS	ETB	UC					F	O	W		F	O	W	6	
0111	7	DEL	IL	ESC	EOT					G	P	X		G	P	X	7	
1000	8	GE	CAN							H	Q	Y		H	Q	Y	8	
1001	9	RLF	EM							I	R	Z		I	R	Z	9	
1010	A	SMM	CC	SM													LVM	
1011	B	VT	CU1	CU2	CU3	.	\$.	*									
1100	C	FF	IFS		DC4	≡	*	%	@									
1101	D	CR	IGS	ENQ	NAK													
1110	E	SO	IRS	ACK														
1111	F	SI	IUS	BEL	SUB												EO	

Note 1: All blanks will be printed with an error symbol.

Note 2: Hex 0 represents bits 0, 1, 2, 3; Hex 1 represents bit 4, 5, 6, 7. Example: Hex D4 is the character "M".

Note 3: 1 = Mark 0 = Space

Example: Bits 7 through 0 of the bit permutation for the character M are 00101011, respectively.

NUL	— NULL	DC3	— Device Control 3	ESC	— Escape
SOH	— Start of Heading	RES	— Restore	SM	— Set Mode
STX	— Start of Text	NL	— New Line	CU2	— Customer User 2
ETX	— End of Text	BS	— Back Space	ENQ	— Enquire
PF	— Punch Off	IL	— Idle	ACK	— Acknowledge
HT	— Horizontal Tab	CAN	— Cancel	BEL	— Bell
LC	— Lower Case	EM	— End of Media	SYN	— Synchronous
DEL	— Delete	CC	— Cursor Control	PN	— Punch On
GE	— Graphics Escape	CUI	— Customer User 1	RS	— Reader Stop
RLF	— Reverse Line Feed	IFS	— Interchange Field Separator	UC	— Upper Case
SMM	— Start of Manual Message	IGS	— Interchange Group Separator	EOT	— End of Transmission
VT	— Vertical Tab	IRS	— Interchange Record Separator	CU3	— Customer User 3
FF	— Form Feed	IUS	— Interchange Unit Separator	DC4	— Device Control 4
CR	— Carriage Return	DS	— Digit Select	NAK	— Negative Acknowledge
SO	— Shift-Out	SOS	— Start of Significance	SUB	— Substitute
SI	— Shift-In	FS	— Field Separator	SP	— Space
DLE	— Data Link Escape	BYP	— By Pass	LVM	— Long Vertical Mark
DC1	— Device Control 1	LF	— Line Feed	EO	— Eight Ones
DC2	— Device Control 2	ETB	— End of Transmission Block		

ACTIVATING PRINTER OPTIONS

Note: Selection of 50 Hz or 60 Hz sprocket for the motor: The printer is shipped with a 60 Hz sprocket; a 50 Hz sprocket is also shipped with the motor and is mounted on a plate at the left side of the unit. If the sprocket is changed for 50 Hz, perform the Impeller Shaft Drive Belt Tension adjustment. Also check the Clutch Drive Belt Tension adjustment. Refer to Section 582-210-700.

80- or 132-Column Tractor Printer

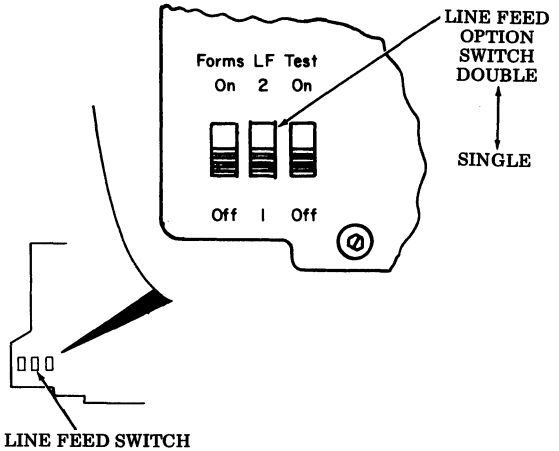

20. Line Feed on Printer		LF Switch
a.	Single	1
b.	Double	2

*

80- or 132-Column Tractor Printer

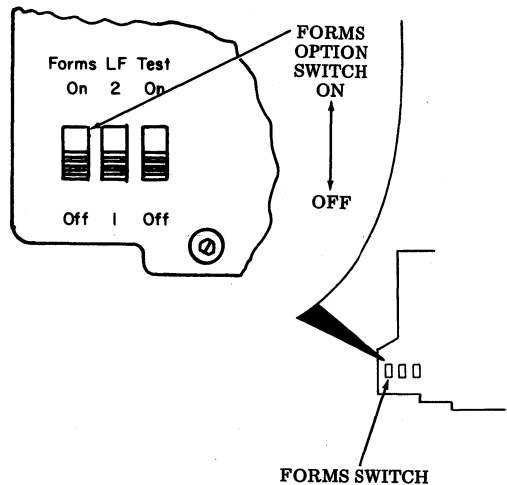

39. Forms	
a.	On
b.	Off

*

*Factory installed.

410071 Printer Logic Circuit Card (80-Column Tractor Feed)

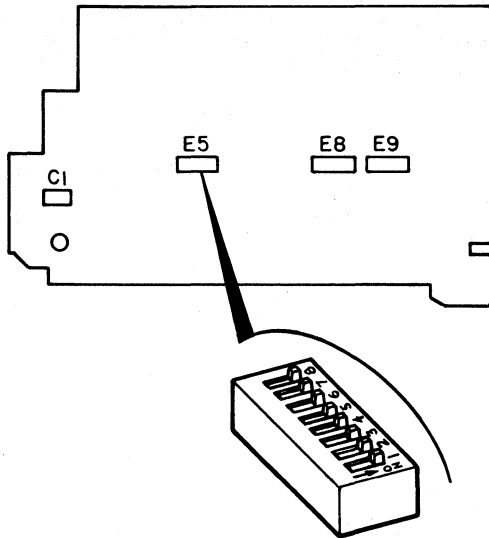

(Printer Circuit Card Viewed From Beneath Printer — Access to Switches is Through a Cutout in Bottom Pan of Printer.)

17. Printer Left Margin and Form Width		E5								
		1	2	3	4	5	6	7	8	
a.	First Printed Column — Column 1	—	—	●	●	●	●	—	—	*
	First Printed Column — Column 2	—	—	●	●	○	●	—	—	
	First Printed Column — Column 3	—	—	●	●	○	○	—	—	
	First Printed Column — Column 4	—	—	●	○	○	○	—	—	
	First Printed Column — Column 5	—	—	○	○	●	○	—	—	
	First Printed Column — Column 6	—	—	○	○	○	●	—	—	
b.(X)	First Printed Column — Column 7	—	—	○	●	○	○	—	—	
(Note)	First Printed Column — Column 8	—	—	●	○	●	○	—	—	
	First Printed Column — Column 9	—	—	○	○	●	●	—	—	
	First Printed Column — Column 10	—	—	○	●	○	●	—	—	
	First Printed Column — Column 11	—	—	●	●	○	○	—	—	
	First Printed Column — Column 12	—	—	●	○	○	●	—	—	
	First Printed Column — Column 13	—	—	○	●	●	○	—	—	

Note 1: (X) indicates desired column number.

Note 2: Choose Option 17.a.

Legend:

- Indicates dot end of rocker switch depressed, toggle or slide positioned to ON.
- Indicates blank end of rocker switch depressed, toggle or slide positioned to OFF.
- Position of switch does not affect option.
- * Factory installed.

410071 Printer Logic Circuit Card (80-Column Tractor Feed) (Cont)

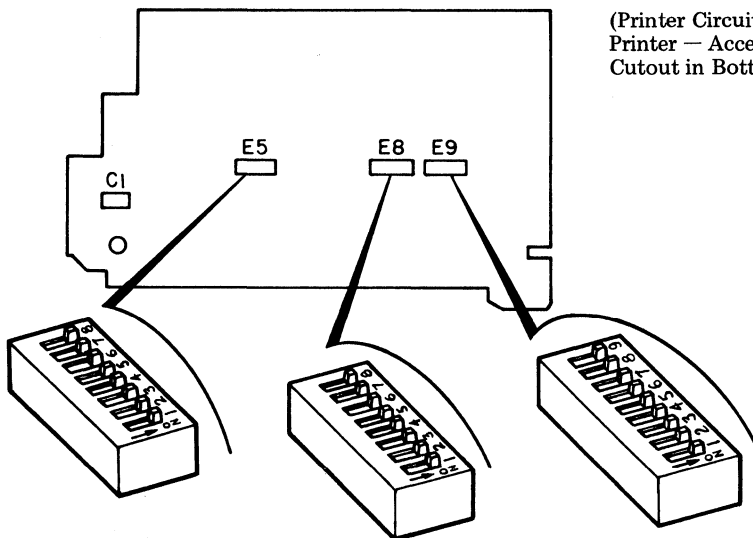

(Printer Circuit Card Viewed From Beneath Printer — Access to Switches is Through a Cutout in Bottom Pan of Printer.)

17. Printer Right Margin and Form Width		E9									E5								E8									
(Note 1)	Last Char Printed Column Number	1	2	3	4	5	6	7	8	9	1	2	3	4	5	6	7	8	1	2	3	4	5	6	7	8		
c.	80	○	●	—	●	○	—	—	—	—	●	—	—	—	—	—	—	—	●	●	—	—	—	—	—	—	●	*
d. (X)	73 61 49 37 25	●	●	—	●	●	—	—	—	—	●	—	—	—	—	—	—	—	●	●	—	—	—	—	—	—	—	—
(Note 2)	74 62 50 38 26	○	●	—	●	●	—	—	—	—	●	—	—	—	—	—	—	—	●	●	—	—	—	—	—	—	—	—
	75 63 51 39 27	●	○	—	●	●	—	—	—	—	●	—	—	—	—	—	—	—	●	●	—	—	—	—	—	—	—	—
	76 64 52 40 28	●	●	—	○	●	—	—	—	—	●	—	—	—	—	—	—	—	●	●	—	—	—	—	—	—	—	—
	77 65 53 41 29	○	●	—	○	●	—	—	—	—	●	—	—	—	—	—	—	—	●	●	—	—	—	—	—	—	—	—
	78 66 54 42 30	●	○	—	○	●	—	—	—	—	●	—	—	—	—	—	—	—	●	●	—	—	—	—	—	—	—	—
	79 67 55 43 31	●	●	—	●	○	—	—	—	—	●	—	—	—	—	—	—	—	●	●	—	—	—	—	—	—	—	—
	68 56 44 32	○	●	—	●	○	—	—	—	—	●	—	—	—	—	—	—	—	●	●	—	—	—	—	—	—	—	—
	69 57 45 33	●	○	—	●	○	—	—	—	—	●	—	—	—	—	—	—	—	●	●	—	—	—	—	—	—	—	—
	70 58 46 34	●	●	—	○	○	—	—	—	—	●	—	—	—	—	—	—	—	●	●	—	—	—	—	—	—	—	—
	71 59 47 35	○	●	—	○	○	—	—	—	—	●	—	—	—	—	—	—	—	●	●	—	—	—	—	—	—	—	—
	72 60 48 36	●	○	—	○	○	—	—	—	—	●	—	—	—	—	—	—	—	●	●	—	—	—	—	—	—	—	—

To obtain counts:

73 through 80 program as shown.

61 through 72 program as shown, then operate E8 position 8 to OFF.

49 through 60 program as shown, then operate E5 position 1 to OFF.

37 through 48 program as shown, then operate E5 position 7 to OFF.

25 through 36 program as shown, then operate E5 position 8 to OFF.

Note 1: For Integrated Synchronous ROP, choose c. The diode representing the last printing column must be removed in Option 122.

Note 2: (X) indicates desired column number; d does not apply to Integrated Synchronous ROP.

(See Legend for ●, ○, —, and * under Option 17, Page 34.

410071 Printer Logic Circuit Card (80-Column Tractor Feed) (Cont)

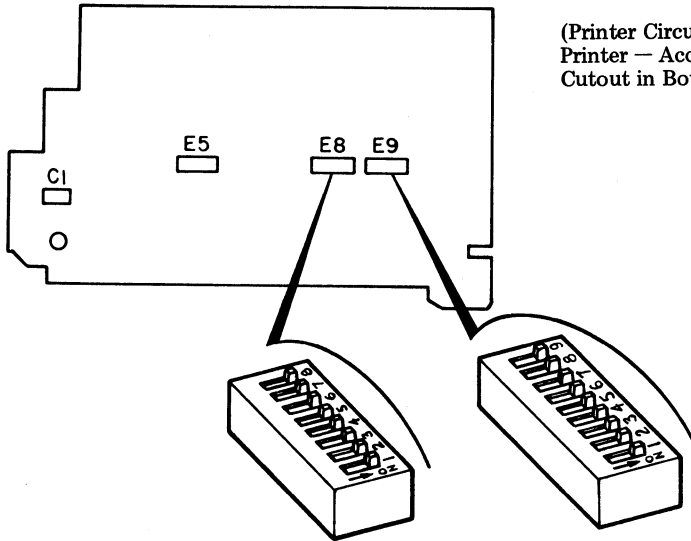

(Printer Circuit Card Viewed From Beneath Printer — Access to Switches is Through a Cutout in Bottom Pan of Printer.)

18. Printer Paper Feedout		E8							
		1	2	3	4	5	6	7	8
a.	No Paper Feedout	—	—	●	—	—	—	—	—
b.	Paper Feedout on DSR or RM Loss — 16 Lines or One Form	—	○	○	—	—	—	—	—
c.	Paper Feedout on DSR or RM Loss or ETX — 16 Lines or One Form	—	●	○	—	—	—	—	*

19. Printer Errored Character Symbol (See Note)		E9								
		1	2	3	4	5	6	7	8	9
a.	Printed on Even Parity Error	—	—	—	—	—	○	●	—	*
b.	Printed on Odd Parity Error	—	—	—	—	—	●	○	—	—
c.	Not Printed on Parity Error	—	—	—	—	—	●	●	—	—

Note : Choose 19.a. or .c.

19. Character Set (See Note)		E8							
		1	2	3	4	5	6	7	8
d.	Printers With 96-Character Set	—	—	—	—	●	○	—	—
e.	Printers With 64-Character Set	—	—	—	—	○	●	—	*
f.	Printers With Extended ASCII Character Set	—	—	—	—	○	○	—	—
g.	Printers With Longest Character Set Having Less Than 64 Characters	—	—	—	—	○	○	—	—

Note: Choose d, e or g to match type carrier.

(See Legend for ●, ○, —, and * under Option 17, Page 34.)

410071 Printer Logic Circuit Card (80-Column Tractor Feed) (Cont)

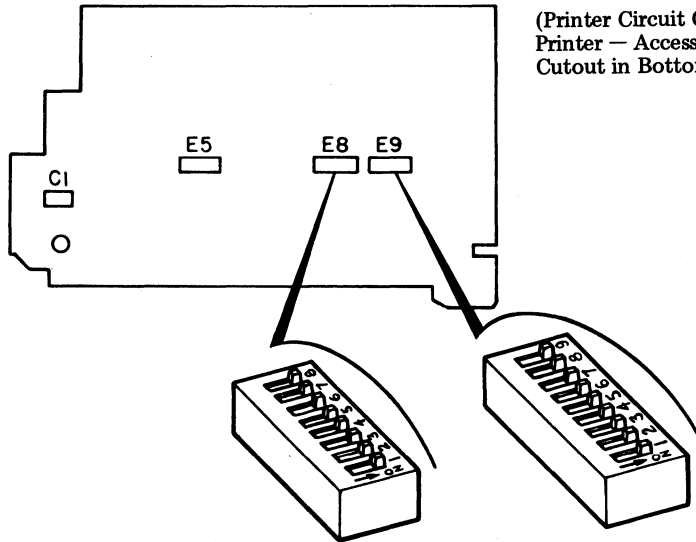

(Printer Circuit Card Viewed From Beneath Printer — Access to Switches is Through a Cutout in Bottom Pan of Printer.)

21. Foldover on Printers With 96-Character Set		E8								
		1	2	3	4	5	6	7	8	
a.	Lower Case and Upper Case Print	○	—	—	—	—	—	—	—	*
b.	Lower Case Prints as Upper Case	●	—	—	—	—	—	—	—	

22. Foldover on Printers With 64-Character Set		E8								
		1	2	3	4	5	6	7	8	
a.	Lower Case Prints as Error Symbol	○	—	—	—	—	—	—	—	*
b.	Lower Case Prints as Upper Case	●	—	—	—	—	—	—	—	

23. Extended ASCII on Printer (Extended ASCII)		E9									
		1	2	3	4	5	6	7	8	9	
a.	Prints Extended ASCII Characters (No Parity Check)	—	—	—	—	—	○	○	—	—	
b.	Does Not Print Extended ASCII (See Option 19a, b, or c.)	—	—	(As in Option 19.)			—	—	—	—	*

Note: Option 23.a. requires local engineering.

(See Legend for ●, ○, —, and * under Option 17, Page 34.)

410071 Printer Logic Circuit Card (80-Column Tractor Feed) (Cont)

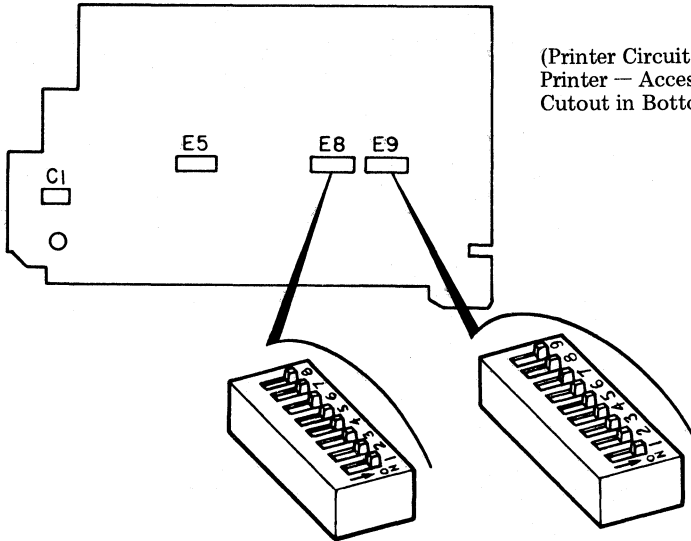

(Printer Circuit Card Viewed From Beneath Printer — Access to Switches is Through a Cutout in Bottom Pan of Printer.)

48. Incomplete Form Suppresses Paper Alarm		E9								
		1	2	3	4	5	6	7	8	9
a.	No (Paper-Out Not Gated With Form-Out)	—	—	—	—	—	—	—	—	●
b.	Yes (Paper-Out Gated With Form-Out)	—	—	—	—	—	—	—	—	○

54. Printing of Escape Sequences Suppressed (See Note)		E9								
		1	2	3	4	5	6	7	8	9
a.	Character After ESC Printed as Received	—	—	—	—	—	—	○	—	—
b.	Printing of Character After ESC Suppressed	—	—	—	—	—	—	—	●	—

Note: This option does not apply to Integrated Synchronous ROP. Either option may be chosen without affecting operation.

55. SI/SO Detection (See Note)		E9								
		1	2	3	4	5	6	7	8	9
a.	SI/SO Detection Not Used	—	—	○	—	—	—	—	—	—
b.	SI/SO Detection Enables Printing Additional Characters	—	—	●	—	—	—	—	—	—

Note: This option does not apply to Integrated Synchronous ROP. Either option may be chosen without affecting operation.

57. SSI/OEM Interface (See Note.)		E8							
		1	2	3	4	5	6	7	8
a.	SSI	—	—	—	—	—	—	●	—
b.	OEM	—	—	—	—	—	—	—	—

Note: Choose Option 57.a.

(See Legend for ●, ○, —, and * under Option 17, Page 34.)

410071 Printer Logic Circuit Card (80-Column Tractor Feed) (Cont)

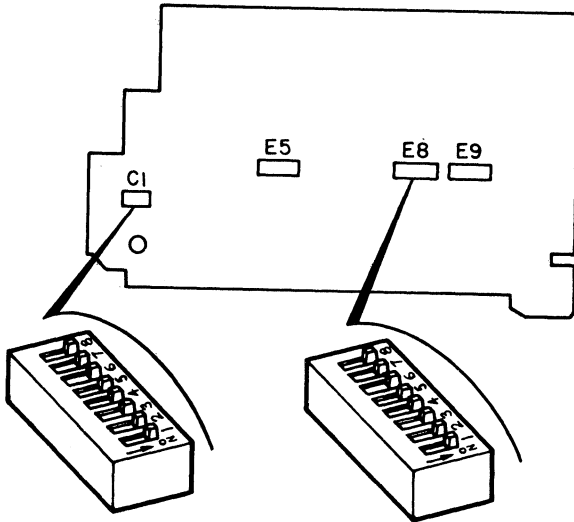

(Printer Circuit Card Viewed From Beneath Printer — Access to Switches is Through a Cutout in Bottom Pan of Printer.)

58. Idle Line Motor Control (See Note)		E8								
		1	2	3	4	5	6	7	8	
a.	Disabled — Motor Held on Indefinitely During Idle Line	—	—	—	○	—	—	—	—	*
b.	Enabled — Motor Turned Off After 40-Second Idle Line	—	—	—	●	—	—	—	—	

Note: Choose Option 58.a.

59. Speed Selection (Applies only if Option 57b is selected) (See Note)		C1								
		1	2	3	4	5	6	7	8	
a.	75 Baud	●	○	○	○	○	○	○	○	
b.	150 Baud	○	●	○	○	○	○	○	○	
c.	300 Baud	○	○	○	○	○	○	○	●	
d.	600 Baud	○	○	●	○	○	○	○	○	
e.	1200 Baud	○	○	○	○	○	●	○	○	
f.	2400 Baud	○	○	○	●	○	○	○	○	*
g.	4800 Baud	○	○	○	○	●	○	○	○	
h.	9600 Baud	○	○	○	○	○	○	●	○	

Note: This option does not apply to Integrated Synchronous ROP. Any option may be chosen without affecting operation.

(See Legend for ●, ○, —, and * under Option 17, Page 34.)

410071 Printer Logic Circuit Card (80-Column Tractor Feed) (Cont)

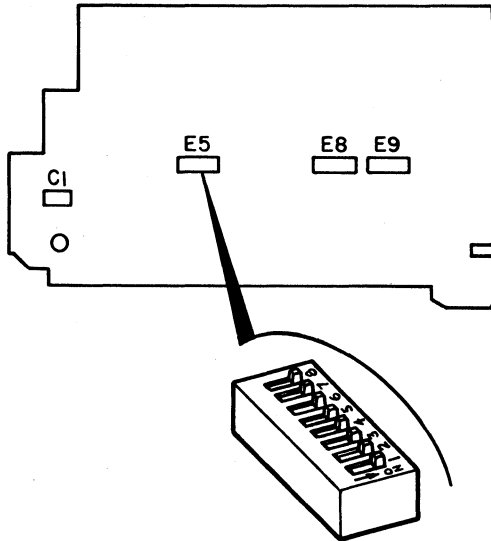

(Printer Circuit Card Viewed From Beneath Printer — Access to Switches is Through a Cutout in Bottom Pan of Printer.)

60. Aux Alarm (See Note)		E5							
		1	2	3	4	5	6	7	8
a.	Enable	—	○	—	—	—	—	—	—
b.	Disable	—	●	—	—	—	—	—	—

*

Note 1: Future alarm mechanism. Switch must be closed when alarm mechanism is not present. Choose Option 60.b. for Integrated Synchronous ROP.

Note 2: Refer to Page 47 for Option 61.

(See Legend for ●, ○, —, and * under Option 17, Page 34.)

410072 Printer Logic Circuit Card (132-Column Tractor Feed)

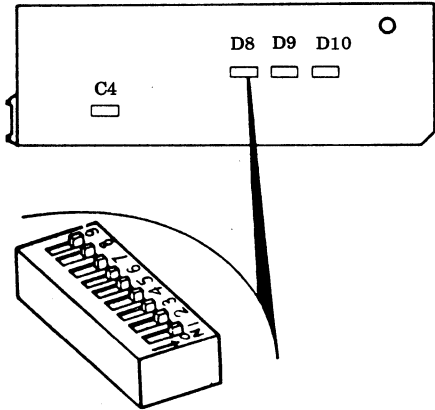

(Printer Circuit Card Viewed From Beneath Printer — Access to Switches is Through a Cutout in Bottom Pan of Printer.)

17. Printer Left Margin and Form Width		D8									
		1	2	3	4	5	6	7	8	9	
a.	First Printed Column — Column 1	—	—	●	●	●	●	—	—	—	*
	First Printed Column — Column 2	—	—	●	●	○	●	—	—	—	
	First Printed Column — Column 3	—	—	●	●	○	○	—	—	—	
	First Printed Column — Column 4	—	—	●	○	○	○	—	—	—	
b.(X)	First Printed Column — Column 5	—	—	○	○	●	○	—	—	—	
(Note)	First Printed Column — Column 6	—	—	○	○	○	●	—	—	—	
	First Printed Column — Column 7	—	—	○	●	○	○	—	—	—	
	First Printed Column — Column 8	—	—	●	○	●	○	—	—	—	
	First Printed Column — Column 9	—	—	○	○	●	●	—	—	—	
	First Printed Column — Column 10	—	—	○	●	○	○	—	—	—	
	First Printed Column — Column 11	—	—	●	●	○	○	—	—	—	
	First Printed Column — Column 12	—	—	●	○	○	●	—	—	—	
	First Printed Column — Column 13	—	—	○	●	●	○	—	—	—	

Note 1: (X) indicates desired column number.

Note 2: Choose Option 17.a.

(See Legend for ●, ○, —, and * under Option 17, Page 34.)

410072 Printer Logic Circuit Card (132-Column Tractor Feed) (Cont)

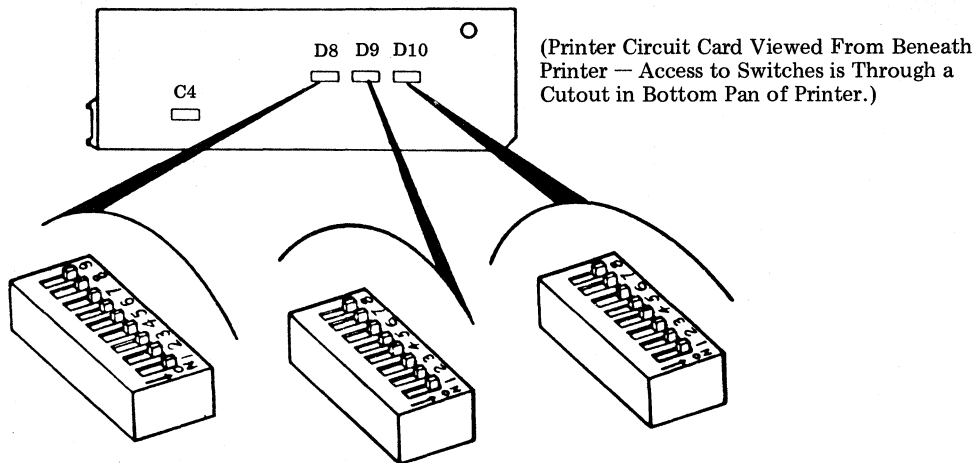

17. Printer Right Margin and Form Width		D8									D9								D10							
(Note 1)	Last Char Printed Column Number	1	2	3	4	5	6	7	8	9	1	2	3	4	5	6	7	8	1	2	3	4	5	6	7	8
e.	132	—	—	—	—	—	—	●	●	—	—	—	—	—	—	—	—	●	●	●	○	—	○	○	—	—
f.(X)	121 109 97 85 73	—	—	—	—	—	—	●	●	—	—	—	—	—	—	—	—	●	●	●	○	—	●	●	—	—
(Note 2)	122 110 98 86 74	—	—	—	—	—	—	●	●	—	—	—	—	—	—	—	—	●	●	○	●	—	●	●	—	—
	123 111 99 87 75	—	—	—	—	—	—	●	●	—	—	—	—	—	—	—	—	●	●	○	—	—	●	●	—	—
	124 112 100 88 76	—	—	—	—	—	—	●	●	—	—	—	—	—	—	—	—	●	●	●	—	—	○	—	—	—
	125 113 101 89 77	—	—	—	—	—	—	●	●	—	—	—	—	—	—	—	—	●	●	○	—	—	○	●	—	—
	126 114 102 90 78	—	—	—	—	—	—	●	●	—	—	—	—	—	—	—	—	●	●	○	—	—	○	—	—	—
	127 115 103 91 79	—	—	—	—	—	—	●	●	—	—	—	—	—	—	—	—	●	●	●	—	—	●	○	—	—
	128 116 104 92 80	—	—	—	—	—	—	●	●	—	—	—	—	—	—	—	—	●	●	○	—	—	●	○	—	—
	129 117 105 93 81	—	—	—	—	—	—	●	●	—	—	—	—	—	—	—	—	●	●	○	—	—	○	—	—	—
	130 118 106 94 82	—	—	—	—	—	—	●	●	—	—	—	—	—	—	—	—	●	●	●	—	—	○	○	—	—
	131 119 107 95 83	—	—	—	—	—	—	●	●	—	—	—	—	—	—	—	—	●	●	○	—	—	○	○	—	—
	120 108 96 84	—	—	—	—	—	—	●	●	—	—	—	—	—	—	—	—	●	●	●	○	—	○	○	—	—

To obtain counts:

- 121 through 132 program as shown.
- 109 through 120 program as shown, then operate D9 position 7 OFF.
- 97 through 108 program as shown, then operate D9 position 8 OFF.
- 85 through 96 program as shown, then operate D8 position 7 OFF.
- 73 through 84 program as shown, then operate D8 position 8 OFF.

Note 1: For Integrated Synchronous ROP, choose e. The diode representing the last printing column must be removed in Option 122.

Note 2: (X) indicates desired column number.

(See Legend for ●, ○, —, and * under Option 17, Page 34.)

410072 Printer Logic Circuit Card (132-Column Tractor Feed) (Cont)

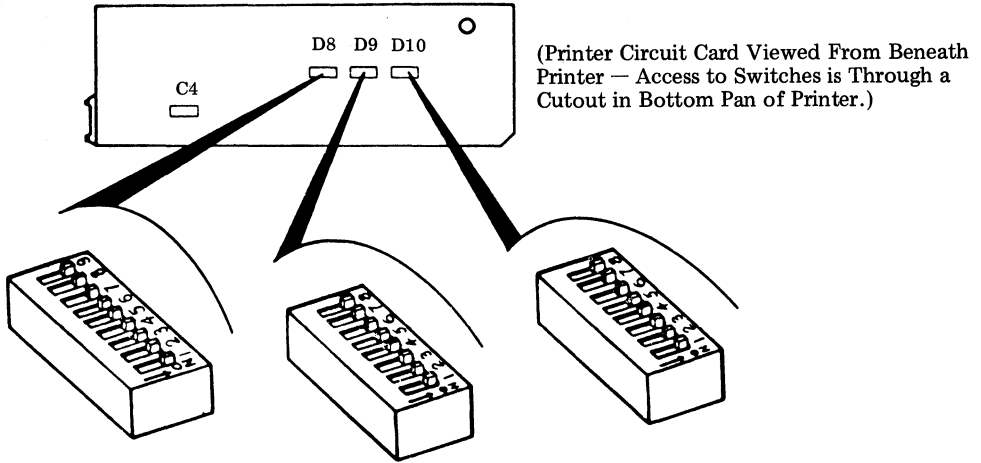

18. Printer Paper Feedout	D9							
	1	2	3	4	5	6	7	8
a. No Paper Feedout	—	—	●	—	—	—	—	—
b. Paper Feedout on DSR or RM Loss — 16 Lines or One Form	—	○	○	—	—	—	—	—
c. Paper Feedout on DSR or RM Loss or ETX — 16 Lines or One Form	—	●	○	—	—	—	—	—

19. Printer Errored Character Symbol (See Note)	D10							
	1	2	3	4	5	6	7	8
a. Printed on Even Parity Error	—	—	—	—	—	○	●	—
b. Printed on Odd Parity Error	—	—	—	—	—	●	○	—
c. Printed on Parity Error	—	—	—	—	—	●	●	—

Note: Choose 19.a. or .c.

19. Character Set (See Note)	D8								
	1	2	3	4	5	6	7	8	9
d. Printers With 96-Character Set (Up-Low)	●	○	—	—	—	—	—	—	—
e. Printers With 64-Character Set (Monocase)	○	●	—	—	—	—	—	—	—
f. Printers With Extended ASCII Character Set	○	○	—	—	—	—	—	—	—
g. Printers With Longest Character Set Having Less Than 64 Characters	○	○	—	—	—	—	—	—	—

Note: Choose d, e or g to match type carrier.

(See Legend for ●, ○, —, and * under Option 17, Page 34.)

410072 Printer Logic Circuit Card (132-Column Tractor Feed) (Cont)

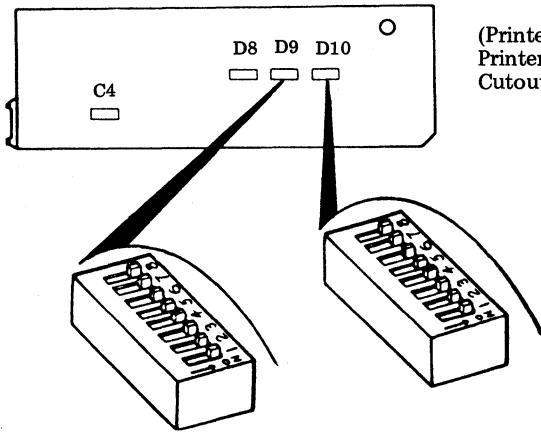

(Printer Circuit Card Viewed From Beneath Printer — Access to Switches is Through a Cutout in Bottom Pan of Printer.)

21. Foldover on Printers With 96-Character Set	D9							
	1	2	3	4	5	6	7	8
a. Lower Case and Upper Case Print	○	—	—	—	—	—	—	—
b. Lower Case Prints as Upper Case	●	—	—	—	—	—	—	—

22. Foldover on Printers With 64-Character Set	D9							
	1	2	3	4	5	6	7	8
a. Lower Case Prints as Error Symbol	○	—	—	—	—	—	—	—
b. Lower Case Prints as Upper Case	●	—	—	—	—	—	—	—

23. Extended ASCII on Printer (Extended ASCII)	E1							
	1	2	3	4	5	6	7	8
a. Prints Extended ASCII Characters (No Parity Check)	—	—	—	—	—	—	—	—
b. Does Not Print Extended ASCII (See Option 19a, b, or c.)	—	—	—	(As in Option 19)	—	—	—	—

Note: Option 23.a. requires local engineering.

(See Legend for ●, ○, —, and * under Option 17, Page 34.)

410072 Printer Logic Circuit Card (132-Column Tractor Feed) (Cont)

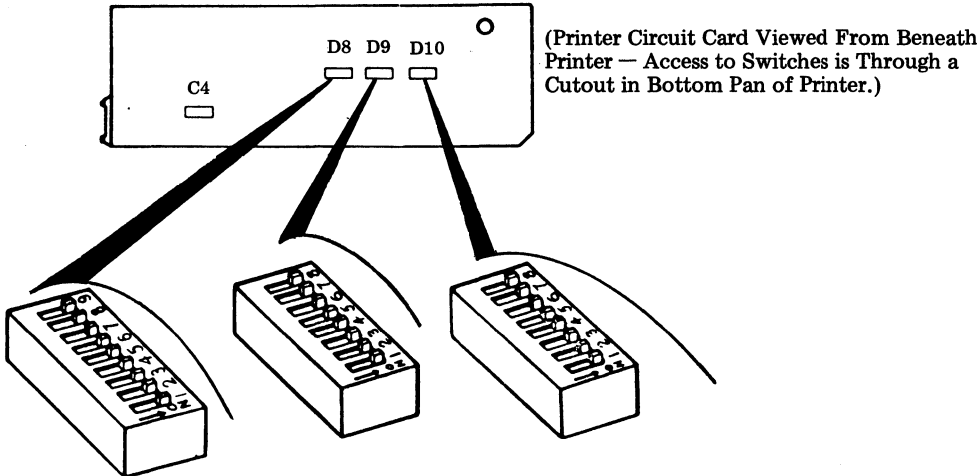

48. Incomplete Form Suppresses Paper Alarm	D9							
	1	2	3	4	5	6	7	8
a. No (Paper-Out Not Gated With Form-Out)	—	—	—	●	—	—	—	—
b. Yes (Paper-Out Gated With Form-Out)	—	—	—	○	—	—	—	—

54. Printing of Escape Sequences Suppressed (See Note)	D10							
	1	2	3	4	5	6	7	8
a. Character After ESC Printed as Received	—	—	—	—	—	—	—	○
b. Printing of Character After ESC Suppressed	—	—	—	—	—	—	—	●

Note: This option does not apply to Integrated Synchronous ROP. Either option may be chosen without affecting operation.

55. SI/SO Detection (See Note)	D10							
	1	2	3	4	5	6	7	8
a. SI/SO Detection Not Used	—	—	○	—	—	—	—	—
b. SI/SO Detection Enables Printing Additional Characters	—	—	●	—	—	—	—	—

Note: This option does not apply to Integrated Synchronous ROP. Either option may be chosen without affecting operation.

57. SSI/OEM Interface (See Note)	D8								
	1	2	3	4	5	6	7	8	9
a. SSI	—	—	—	—	—	—	—	—	●
b. OEM	—	—	—	—	—	—	—	—	○

Note: Choose Option 57.a.

(See Legend for ●, ○, —, and * under Option 17, Page 34.)

410072 Printer Logic Circuit Card (132-Column Tractor Feed) (Cont)

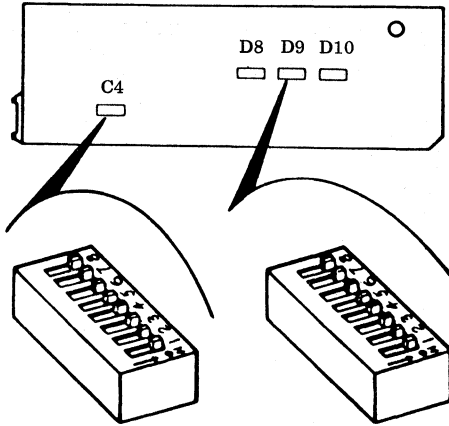

(Printer Circuit Card Viewed From Beneath Printer — Access to Switches is Through a Cutout in Bottom Pan of Printer.)

58. Idle Line Motor Control (See Note)		D9								
		1	2	3	4	5	6	7	8	
a.	Disabled — Motor Held On Indefinitely During Idle Line	—	—	—	—	—	○	—	—	*
b.	Enabled — Motor Turned Off After 40-Second Idle Line	—	—	—	—	—	●	—	—	

Note: Choose Option 58.a.

59. Speed Selection (Applies Only if Option 57.b. is Selected)		C4								
		1	2	3	4	5	6	7	8	
a.	75 Baud	●	○	○	○	○	○	○	○	
b.	150 Baud	○	●	○	○	○	○	○	○	
c.	300 Baud	○	○	○	●	○	○	○	○	
d.	600 Baud	○	○	●	○	○	○	○	○	
e.	1200 Baud	○	○	○	○	○	○	●	○	
f.	2400 Baud	○	○	○	○	●	○	○	○	*
g.	4800 Baud	○	○	○	○	○	●	○	○	
h.	9600 Baud	○	○	○	○	○	○	○	●	

Note: This option does not apply to Integrated Synchronous ROP. Any option may be chosen without affecting operation.

(See Legend for ●, ○, —, and * under Option 17, Page 34.)

410072 Printer Logic Circuit Card (132-Column Tractor Feed) (Cont)

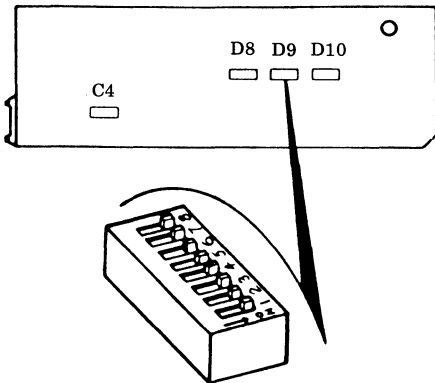

(Printer Circuit Card Viewed From Beneath Printer — Access to Switches is Through a Cutout in Bottom Pan of Printer.)

60. Aux Alarm		D9							
		1	2	3	4	5	6	7	8
a.	Enable	—	—	—	—	○	—	—	—
b.	Disable	—	—	—	—	●	—	—	—

Note: Future alarm mechanism. Switch must be closed when alarm mechanism is not present. Choose Option 60.b. for Integrated Synchronous ROP.

410151 Circuit Card (80- or 132-Column Tractor Feed)

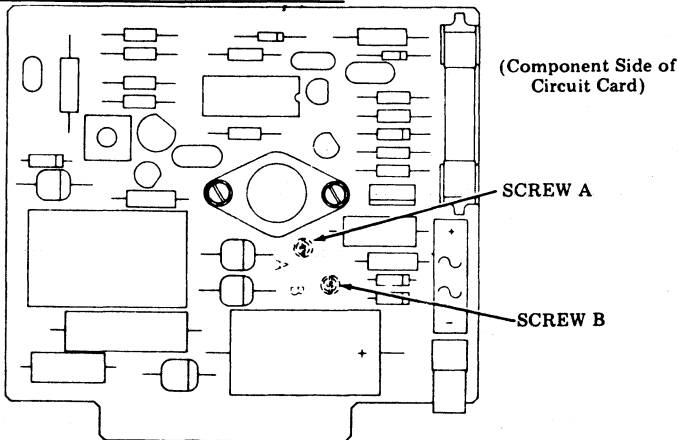

61. Regulator Grounding (Circuit Gnd to Frame Gnd) (See Note)		Screw A		Screw B	
		Component	Noncomponent	Component	Noncomponent
a.	SSI	In	—	—	In
b.	(OEM) At Printer	In	—	In	—
c.	(OEM) Ext to Printer	—	In	In	—

Note: Choose Option 61.c. for Integrated Synchronous ROP.

(See Legend for ●, ○, —, and * under Option 17, Page 34.)

ACTIVATING CONTROLLER OPTIONS

TABLE E

410734 Diode Matrix Circuit Card

LEFT MARGIN DIODE LOCATION

121.	Left Margin Setting	R1, b0 to R2, b7 *
a.	Left Margin at Column 1 (See Note)	<input type="checkbox"/> All
b.	Left Margin at Column 2 or Beyond	<input checked="" type="checkbox"/> Table E

COLUMN	DIODE	COLUMN	DIODE
		9	R2, b0
2	R1, b1	10	R2, b1
3	R1, b2	11	R2, b2
4	R1, b3	12	R2, b3
5	R1, b4	13	R2, b4
6	R1, b5	14	R2, b5
7	R1, b6	15	R2, b6
8	R1, b7	16	R2, b7

Note: Diode R1 b0 is NOT cut for Option 121a or b.

Cut and remove () only the diode corresponding to the desired left margin position (printer column) as listed in Table E. If the printer left margin is required to be at column 17 or beyond, refer to the table for Option 122 for the diode location. See Note above for exception.

Option 121.a. requires selection of Option 131.a.
 Option 121.b. requires selection of Option 131.b.

Example: Option 121.b. shown selected for printer left margin at printer column 4.

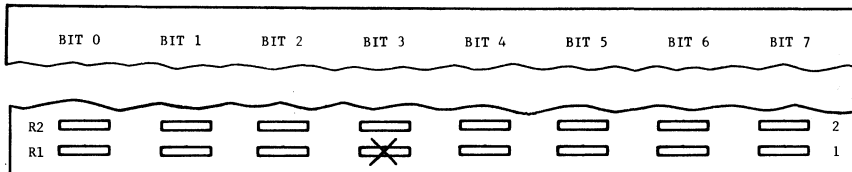

122.	Horizontal Tabulation Settings	R1, b0 to R17, b3 *
a.	No Horizontal Tab Settings (See Note)	<input type="checkbox"/> (ALL)
b.	Preselected Horizontal Tab Settings in Any Column Through 80 (80-Column Printer) or Through 132 (132-Column Printer) (See Note)	<input checked="" type="checkbox"/> Table F

Note: Diode R1, b0 is NOT cut for Option 122a or b.

When selecting horizontal tab settings for a particular customer application, remember that the printer spaces, prints and tabs at 10 character/columns per inch.

Horizontal tab settings to the left of, or the same as the left margin setting of Option 121b should, obviously, be avoided. Cutting and removing a lower numbered diode than chosen for the left margin setting will result in a new left margin at a lower numbered column and the left margin established by Option 121b will become a horizontal tab stop. Similiary, horizontal tab selecting beyond 80 columns must be avoided for 80-column printers.

Cut and remove () the diode(s) corresponding to the desired horizontal tab setting(s), as shown in Table F. Also cut and remove diode at R10, b7 for an 80-Column printer or diode at R17, b3 for a 132-Column printer.

- Diode left in.
- Diode cut and removed.

* Factory Installed

410734 Diode Matrix Circuit Card (Cont)

Diodes R17, b4 through b7 have no present application and should be left in place.

TABLE F
HORIZONTAL TAB SETTING DIODE

TAB COLUMN	TAB DIODE	TAB COLUMN	TAB DIODE	TAB COLUMN	TAB DIODE	TAB COLUMN	TAB DIODE
1	R1,b0	34	R5,b1	67	R9,b2	100	R13,b3
2	R1,b1	35	R5,b2	68	R9,b3	101	R13,b4
3	R1,b2	36	R5,b3	69	R9,b4	102	R13,b5
4	R1,b3	37	R5,b4	70	R9,b5	103	R13,b6
5	R1,b4	38	R5,b5	71	R9,b6	104	R13,b7
6	R1,b5	39	R5,b6	72	R9,b7	105	R14,b0
7	R1,b6	40	R5,b7	73	R10,b0	106	R14,b1
8	R1,b7	41	R6,b0	74	R10,b1	107	R14,b2
9	R2,b0	42	R6,b1	75	R10,b2	108	R14,b3
10	R2,b1	43	R6,b2	76	R10,b3	109	R14,b4
11	R2,b2	44	R6,b3	77	R10,b4	110	R14,b5
12	R2,b3	45	R6,b4	78	R10,b5	111	R14,b6
13	R2,b4	46	R6,b5	79	R10,b6	112	R14,b7
14	R2,b5	47	R6,b6	80	R10,b7	113	R15,b0
15	R2,b6	48	R6,b7	81	R11,b0	114	R15,b1
16	R2,b7	49	R7,b0	82	R11,b1	115	R15,b2
17	R3,b0	50	R7,b1	83	R11,b2	116	R15,b3
18	R3,b1	51	R7,b2	84	R11,b3	117	R15,b4
19	R3,b2	52	R7,b3	85	R11,b4	118	R15,b5
20	R3,b3	53	R7,b4	86	R11,b5	119	R15,b6
21	R3,b4	54	R7,b5	87	R11,b6	120	R15,b7
22	R3,b5	55	R7,b6	88	R11,b7	121	R16,b0
23	R3,b6	56	R7,b7	89	R12,b0	122	R16,b1
24	R3,b7	57	R8,b0	90	R12,b1	123	R16,b2
25	R4,b0	58	R8,b1	91	R12,b2	124	R16,b3
26	R4,b1	59	R8,b2	92	R12,b3	125	R16,b4
27	R4,b2	60	R8,b3	93	R12,b4	126	R16,b5
28	R4,b3	61	R8,b4	94	R12,b5	127	R16,b6
29	R4,b4	62	R8,b5	95	R12,b6	128	R16,b7
30	R4,b5	63	R8,b6	96	R12,b7	129	R17,b0
31	R4,b6	64	R8,b7	97	R13,b0	130	R17,b1
32	R4,b7	65	R9,b0	98	R13,b1	131	R17,b2
33	R5,b0	66	R9,b1	99	R13,b2	132	R17,b3

410734 Diode Matrix Circuit Card (Cont)

Example: Option 122b shown optioned for 80-column printer with tab stops at printer columns 10, 20, 30, 40, 50, 60, 70 and with diode representing 80th column (R10, b7) removed.

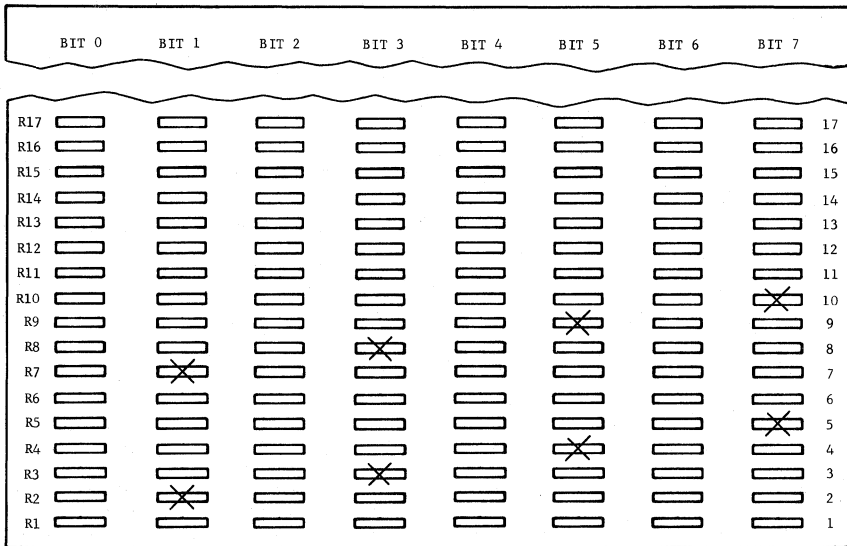

123. Vertical Tab Settings		R18, b0 to R29, b7
a.	No Vertical Tab Settings	<input type="checkbox"/> (ALL)
c.	1st Vertical Tab Line	<input checked="" type="checkbox"/> R18, TABLE G
d.	2nd Vertical Tab Line	<input checked="" type="checkbox"/> R19, TABLE G
e.	3rd Vertical Tab Line	<input checked="" type="checkbox"/> R20, TABLE G
f.	4th Vertical Tab Line	<input checked="" type="checkbox"/> R21, TABLE G
g.	5th Vertical Tab Line	<input checked="" type="checkbox"/> R22, TABLE G
h.	6th Vertical Tab Line	<input checked="" type="checkbox"/> R23, TABLE G
i.	7th Vertical Tab Line	<input checked="" type="checkbox"/> R24, TABLE G
j.	8th Vertical Tab Line	<input checked="" type="checkbox"/> R25, TABLE G
k.	9th Vertical Tab Line	<input checked="" type="checkbox"/> R26, TABLE G
l.	10th Vertical Tab Line	<input checked="" type="checkbox"/> R27, TABLE G
m.	11th Vertical Tab Line	<input checked="" type="checkbox"/> R28, TABLE G
n.	12th Vertical Tab Line	<input checked="" type="checkbox"/> R29, TABLE G

Diode left in.
 Diode cut and removed.

410734 Diode Matrix Circuit Card (Cont)

When selecting vertical tab settings for a particular customer application, remember that the printer line feeds and tabs vertically at 6 lines per inch. Also, Option 20b (double line feed) will, if selected, cause the vertical tab settings to be double the length shown in Table G.

Vertical tab settings that would tab the printer into the next form should obviously be avoided. For example, an 11-inch form would not have a tab setting optioned beyond line 65 of the form.

Selections must be made in increasing line number from 1st vertical tab through 12th vertical tab line. When less than 12 vertical tabs are required, the unused positions (starting with the "12th" vertical tab line) must have all diodes left in.

TABLE G
VERTICAL TAB SETTING DIODEs

TAB LINE	DIODE POSITION**	TAB LINE	DIODE POSITION**	TAB LINE	DIODE POSITION**	TAB LINE	DIODE POSITION**	TAB LINE	DIODE POSITION**
1	0	28	2,3,4	55	0,1,2,4,5	82	1,4,6	109	0,2,3,5,6
2	1	29	0,2,3,4	56	3,4,5	83	0,1,4,6	110	1,2,3,5,6
3	0,1	30	1,2,3,4	57	0,3,4,5	84	2,4,6	111	0,1,2,3,5,6
4	2	31	0,1,2,3,4	58	1,3,4,5	85	0,2,4,6	112	4,5,6
5	0,2	32	5	59	0,1,3,4,5	86	1,2,4,6	113	0,4,5,6
6	1,2	33	0,5	60	2,3,4,5	87	0,1,2,4,6	114	1,4,5,6
7	0,1,2	34	1,5	61	0,2,3,4,5	88	3,4,6	115	0,1,4,5,6
8	3	35	0,1,5	62	1,2,3,4,5	89	0,3,4,6	116	2,4,5,6
9	0,3	36	2,5	63	0,1,2,3,4,5	90	1,3,4,6	117	0,2,4,5,6
10	1,3	37	0,2,5	64	6	91	0,1,3,4,6	118	1,2,4,5,6
11	0,1,3	38	1,2,5	65	0,6	92	2,3,4,6	119	0,1,2,4,5,6
12	2,3	39	0,1,2,5	66	1,6	93	0,2,3,4,6	120	3,4,5,6
13	0,2,3	40	3,5	67	0,1,6	94	1,2,3,4,6	121	0,3,4,5,6
14	1,2,3	41	0,3,5	68	2,6	95	0,1,2,3,4,6	122	1,3,4,5,6
15	0,1,2,3	42	1,3,5	69	0,2,6	96	5,6	123	0,1,3,4,5,6
16	4	43	0,1,3,5	70	1,2,6	97	0,5,6	124	2,3,4,5,6
17	0,4	44	2,3,5	71	0,1,2,6	98	1,5,6	125	0,2,3,4,5,6
18	1,4	45	0,2,3,5	72	3,6	99	0,1,5,6	126	1,2,3,4,5,6
19	0,1,4	46	1,2,3,5	73	0,3,6	100	2,5,6	127	0,1,2,3,4,5,6
20	2,4	47	0,1,2,3,5	74	1,3,6	101	0,2,5,6	128	7
21	0,2,4	48	4,5	75	0,1,3,6	102	1,2,5,6	129	0,7
22	1,2,4	49	0,4,5	76	2,3,6	103	0,1,2,5,6	130	1,7
23	0,1,2,4	50	1,4,5	77	0,2,3,6	104	3,5,6	131	0,1,7
24	3,4	51	0,1,4,5	78	1,2,3,6	105	0,3,5,6	132	2,7
25	0,3,4	52	2,4,5	79	0,1,2,3,6	106	1,3,5,6		
26	1,3,4	53	0,2,4,5	80	4,6	107	0,1,3,5,6		
27	0,1,3,4	54	1,2,4,5	81	0,4,6	108	2,3,5,6		

** Diode position is preceded by "b".

Diodes indicated by diode position number must be cut and removed.

410734 Diode Matrix Circuit Card (Cont)

Example: Option 123. shown selected to accommodate an 11-inch form with vertical tab stop settings at 10, 20, 30, 45, and 60 lines.

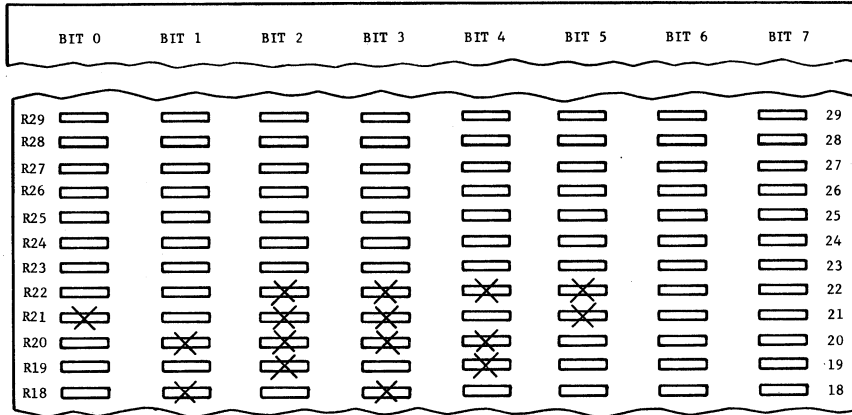

124. Not Present

125.	Type of Printer Used	R46, b6
a.	80-Column Printer	<input type="checkbox"/> *
b.	132-Column Printer	<input checked="" type="checkbox"/>

Note: Option 125 will be factory installed to match the printer used.

126.-130. Not Present

131.	Left Margin	R46, b4
a.	Left Margin Begins at Column 1 Regardless of Selection of Options 121. and 122.	<input type="checkbox"/> *
b.	Left Margin Begins as Selected in Option 121.	<input checked="" type="checkbox"/>

132.-147. Not Present

148.	Motor Turn-Off Delay	R46, b5
a.	Minimum Delay - Motor Turns Off Approximately 30 Seconds After Buffer Empties	<input type="checkbox"/> *
b.	Maximum Delay - Motor Turn Off Delayed Approximately 3 Minutes After Buffer Empties	<input checked="" type="checkbox"/>

149.-158. Not Present

- Diode left in.
- Diode cut and removed.
- *Factory installed.

410734 Diode Matrix Circuit Card (Cont)

159. Variable Characters for System Operation (Notes 1, 2, 3)		DIODE ASSIGNMENT		
		ROW	COLUMN	
			ASCII	EBCDIC
a.	Programmable Character 1	R43	b0-b6	b0-b7
b.	Programmable Character 2	R42	b0-b6	b0-b7
c.	Programmable Character 3	R41	b0-b6	b0-b7
d.	Programmable Character 4	R40	b0-b6	b0-b7
e.	Programmable Character 5	R39	b0-b6	b0-b7
f.	Programmable Character 6	R38	b0-b6	b0-b7
g.	Programmable Character 7	R37	b0-b6	b0-b7
h.	Programmable Character 8 (DLE)	R36	b0-b6	b0-b7
i.	Programmable Character 9 (ZERO)	R35	b0-b6	b0-b7
j.	Programmable Character 10 (ONE)	R34	b0-b6	b0-b7
k.	Programmable Character 11 (EOT)	R33	b0-b6	b0-b7
l.	Programmable Character 12 (NAK)	R32	b0-b6	b0-b7
m.	Programmable Character 13 (ENQ)	R31	b0-b6	b0-b7
n.	Programmable Character 14	R30	b0-b6	b0-b7

Note 1: Program a character for each position except as noted. Remove a diode to encode a mark, retain the diode to encode a space.

Note 2: If Option 160.a. (ASCII) is used (see Table A or C) data bits 1 through 7 are encoded by diodes b0 through b6 respectively, (ie, for marking bit 1 remove diode b0, for marking bit 2 remove diode b1, for marking bit 3 remove diode b2 etc). Diode b7 must be encoded to provide odd parity for the character.

Note 3: If Option 160.b. (EBCDIC) is used, data bits 7 through 0 are encoded by diodes b0 through b7 respectively, (ie, for marking bit 0 remove diode b7, for marking bit 1 remove diode b6, for marking bit 2 remove diode b5 etc).

Note 4: See Paragraph 5. FIELD OPTIONS AND DESCRIPTIONS, Pages 15 and 16 Option 159. for notes.

410734 Diode Matrix Circuit Card (Cont)

160.	Communication Code-Line Operation	R46, b0	
a.	ASCII	<input type="checkbox"/>	*
b.	EBCDIC	<input checked="" type="checkbox"/>	

161.	Future Use	R46, b1	
a.	All Present Applications	<input type="checkbox"/>	*
b.	Possible Future Use	<input checked="" type="checkbox"/>	

162.	Type Font Length	R46, b2	
a.	64 or 96 Characters	<input type="checkbox"/>	*
b.	48 Characters	<input checked="" type="checkbox"/>	

163.	Future Use	R46, b3	
a.	All Present Applications	<input type="checkbox"/>	*
b.	Possible Future Use	<input checked="" type="checkbox"/>	

164.	Block Size	R45, b0	R45, b1
a.	128 Characters	<input type="checkbox"/>	<input checked="" type="checkbox"/>
b.	256 Characters	<input checked="" type="checkbox"/>	<input type="checkbox"/>
c.	512 Characters	<input type="checkbox"/>	<input type="checkbox"/>

165.	Future Use	R45, b2	
a.	All Present Applications	<input type="checkbox"/>	*
b.	Possible Future Use	<input checked="" type="checkbox"/>	

166.	Data Carrier Disconnect	R45, b3	
a.	Disconnect if Carrier is Lost for 30 Seconds or No Carrier Within 30 Seconds After Call Connection	<input type="checkbox"/>	*
b.	No Disconnect on Absence of Carrier	<input checked="" type="checkbox"/>	

167.	Permanent Request-to-Send (RTS)	R45, b4	
a.	RTS ON Only When Required For Transmission	<input type="checkbox"/>	*
b.	RTS ON at All Times That DTR is ON	<input checked="" type="checkbox"/>	

Diode left in.

Diode cut and removed.

* Factory installed.

410734 Diode Matrix Circuit Card (Cont)

168.	Future Use	R45, b5
a.	All Present Applications	<input type="checkbox"/>
b.	Possible Future Use	<input checked="" type="checkbox"/>
169.	Future Use	R45, b6
a.	All Present Applications	<input type="checkbox"/>
b.	Possible Future Use	<input checked="" type="checkbox"/>
170.	Space Extension	R45, b7
a.	Single Space on Space Character	<input type="checkbox"/>
b.	Three Spaces on Space Characters	<input checked="" type="checkbox"/>

171.	Selection Formats (PAD and SYN Characters Omitted)	R44, b0-b7
a.	Point-to-Point Private Line/Switched-Network Without Terminal Identification Providing Device Selection — E A S D (Notes 1, 2, 3, 4, 5) N [C \emptyset] T C Q K X n	<input checked="" type="checkbox"/> b0
b.	Point-to-Point Private Line/Switched-Network Without Terminal Identification or E A S (Notes 2, 3, 4) Device Selection — N [C \emptyset] T Q K X	<input checked="" type="checkbox"/> b1
c.	Multipoint Private Line Providing Device Selection — α # E A S (Notes 1, 2, 3, 4, 7) N [C \emptyset] T Q K X	<input checked="" type="checkbox"/> b2
d.	Multipoint Private Line Without Device Selection — α 1 α 2 E A S (Notes 2, 3, 4, 6, 11) N [α 1 α 2 C \emptyset] T Q K X	<input checked="" type="checkbox"/> b3
e.	Switched-Network With Terminal Identification — Providing Device Selection — α A α B E A S D (Notes 1, 2, 3, 4, 5, 10) N [α 1 α 2 C \emptyset] T C Q K X n	<input checked="" type="checkbox"/> b4
f.	Switched-Network With Terminal Identification; Without Device Selection — α A α B E A S (Notes 2, 3, 4, 10) N [α 1 α 2 C \emptyset] T Q K X	<input checked="" type="checkbox"/> b5
g.	Multipoint Private Line With Device Selection — α 1 α 2 # E A S (Notes 1, 2, 3, 4, 6, 8) N [C \emptyset] T Q K X	<input checked="" type="checkbox"/> b6
h.	Switched-Network Providing Device Selection and Security Identification — α A α B A1 B1 C1 E A S D (Notes 1, 2, 3, 4, 5, 9) N [α 1 α 2 A2 B2 C2 C \emptyset] T C Q K X n	<input checked="" type="checkbox"/> b7

See Paragraph 5. FIELD OPTIONS AND DESCRIPTIONS, Pages 18 and 19, Option 171 for Notes.

Diode left in.

Diode cut and removed.

*Factory installed.

410734 Diode Matrix Circuit Card (Cont)

172.	Future Use	R46, b7
a.	All Present Applications	<input type="checkbox"/>
b.	Possible Future Use	<input checked="" type="checkbox"/>

*

173.	ETB	R47, b0
a.	Block Terminator	<input type="checkbox"/>
b.	Block Terminator, Executes Printing a Line, Executes Vertical Tab ESC Sequence (or NL if None) or Terminates a Horizontal Tab Setting Sequence.	<input checked="" type="checkbox"/>

*

174.	ETX	R47, b1
a.	Block Terminator or Terminates Horizontal Tab Setting Sequence	<input type="checkbox"/>
b.	Block Terminator, Terminates Horizontal Tab Sequence, Executes Printing a Line or Executes Vertical Tab ESC Sequence (or NL if None).	<input checked="" type="checkbox"/>

*

175.	ITB	R47, b2
a.	Intermediate Block Terminator	<input type="checkbox"/>
b.	Block Terminator, Executes Printing a Line, Executes Vertical Tab ESC Sequence (or NL if None) or Terminates Horizontal Tab Setting Sequence.	<input checked="" type="checkbox"/>

*

176.	LINE FEED/NEW LINE	R47, b3
a.	Executes Printing a Line, Executes Vertical Tab ESC Sequence (or NL if None) or Terminates Horizontal Tab Setting Sequence.	<input type="checkbox"/>
b.	SPACE Only	<input checked="" type="checkbox"/>

*

177.	RS or IRS (EBCDIC)	R47, b4
a.	Executes Printing a Line and Executes Vertical Tab ESC Sequence (or NL if None)	<input type="checkbox"/>
b.	SPACE Only	<input checked="" type="checkbox"/>

*

178.	Immediate WACK	R47, b5
a.	Disabled	<input type="checkbox"/>
b.	Enabled	<input checked="" type="checkbox"/>

*

179.	WACK/Buffer Control	R47, b6
a.	WACK Response Enabled, Multiple Block Buffer	<input type="checkbox"/>
b.	WACK Response Disabled, Single Block Buffer	<input checked="" type="checkbox"/>

*

 Diode left in. Diode cut and removed.

*Factory installed.

410734 Diode Matrix Circuit Card (Cont)

180.	Future Use	R47, b7
a.	All Present Applications	<input type="checkbox"/>
b.	Possible Future Use	<input checked="" type="checkbox"/>

*

181.	Future Use	R48, b0
a.	All Present Applications	<input type="checkbox"/>
b.	Possible Future Use	<input checked="" type="checkbox"/>

*

182.	Future Use	R48, b1
a.	All Present Applications	<input type="checkbox"/>
b.	Possible Future Use	<input checked="" type="checkbox"/>

*

183.	Future Use	R48, b2
a.	All Present Applications	<input type="checkbox"/>
b.	Possible Future Use	<input checked="" type="checkbox"/>

*

184.	Future Use	R48, b3
a.	All Present Applications	<input type="checkbox"/>
b.	Possible Future Use	<input checked="" type="checkbox"/>

*

185.	Future Use	R48, b4
a.	All Present Applications	<input type="checkbox"/>
b.	Possible Future Use	<input checked="" type="checkbox"/>

*

186.	Future Use	R48, b5
a.	All Present Applications	<input type="checkbox"/>
b.	Possible Future Use	<input checked="" type="checkbox"/>

*

187.	Future Use	R48, b6
a.	All Present Applications	<input type="checkbox"/>
b.	Possible Future Use	<input checked="" type="checkbox"/>

*

188.	Future Use	R48, b7
a.	All Present Applications	<input type="checkbox"/>
b.	Possible Future Use	<input checked="" type="checkbox"/>

*

Diode left in.

Diode cut and removed.

* Factory installed.

410733 Controller Circuit Card

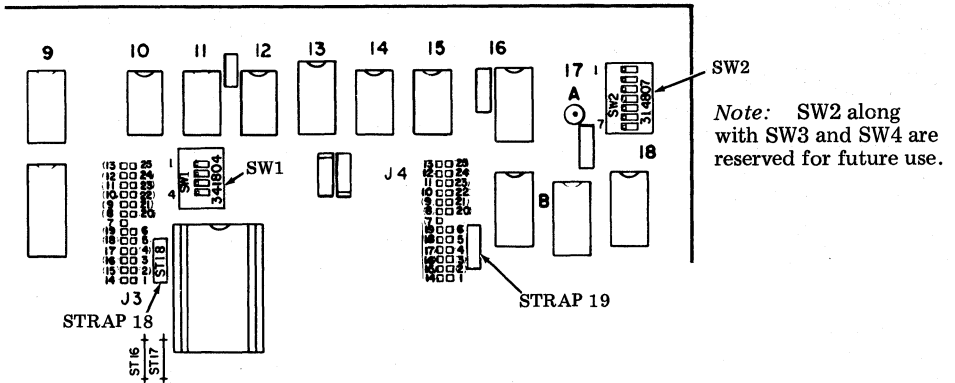

		SW1			
		1	2	3	4
189.	Receiver Clock Control				
a.	Rec. Clock from Associated Data Set	—	—	○	● *
b.	Rec. Clock Generated Internally	—	—	●	○

		SW1			
		1	2	3	4
190.	Transmitter Clock Control				
a.	Trans. Clock from Associated Data Set	○	●	—	— *
b.	Trans. Clock Generated Internally	●	○	—	—

		CUT STRAP	
		18	19
a.	Frame Ground Connected to Signal Ground	NO	NO *
b.	Frame Ground Not Connected to Signal Ground	YES	YES

Note: Where a longer than normal 408065 cable for connecting ROP and data set is used, and when electrical noise is a problem, the frame ground to signal ground connection may be broken at the ROP (Option b) and tied together at another point (as at the data set).

See Legend for ●, ○, —, and * under Option 17, Page 34.)

ACTIVATING DATA SET OPTIONS (Refer to the following tables for the applicable data set options.)



ASSOCIATED TELEPHONE
(When Required)

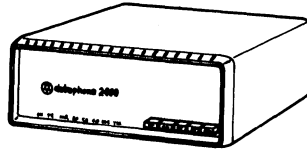

DATA SET 201C

TABLE H
DATA SET 201C OPTIONS*

FEATURE	OPTION	STRAPPING ON ANALOG BOARD (JB1 CP) INSTALL RED STRAPS	STRAPPING ON DIGITAL BOARD (JB2 CP) INSTALL RED STRAPS	REMOVE RED STRAPS FOR OPTION	PROVIDE	
Transmit Line Signal Level	0 dBm	ZA	27-28, 29-30, 31-32, 33-34		ZP	One Per Station
	- 1 dBm	ZB	19-20, 29-30, 31-32, 33-34		ZO	
	- 2 dBm	ZC	27-28, 21-22, 31-32, 33-34		ZN	
	- 3 dBm	ZD	19-20, 21-22, 31-32, 33-34		ZM	
	- 4 dBm	ZE	27-28, 29-30, 23-24, 33-34		ZL	
	- 5 dBm	ZF	19-20, 29-30, 23-24, 33-34		ZK	
	- 6 dBm	ZG	27-28, 21-22, 23-24, 33-34		ZJ	
	- 7 dBm	ZH	19-20, 21-22, 23-24, 33-34		ZI	
	- 8 dBm	ZI	27-28, 29-30, 31-32, 25-26		ZH	
	- 9 dBm	ZJ	19-20, 29-30, 31-32, 25-26		ZG	
	-10 dBm	ZK	27-28, 21-22, 31-32, 25-26		ZF	
	-11 dBm	ZL	19-20, 21-22, 31-32, 25-26		ZE	
	-12 dBm	ZM	27-28, 29-30, 23-24, 25-26		ZD	
	-13 dBm	ZN	19-20, 29-30, 23-24, 25-26		ZC	
	-14 dBm	ZO	27-28, 21-22, 23-24, 25-26		ZB	
-15 dBm	ZP	19-20, 21-22, 23-24, 25-26		ZA		
Line Impedance	600 Ω	ZQ	16-17		ZR	One Per Station
	900 Ω	ZR	17-18		ZQ	
Compromise † Equalizer	IN	ZS	8-9, 11-12		ZT	One Per Station
	OUT	ZT	9-10, 12-13		ZS	
Carrier ON Sensitivity	-24 for PL	ZU			ZV	One Per Station
	-44 for DDD	ZV	1-2			

TABLE H (Cont)
DATA SET 201C OPTIONS*

FEATURE		OPTION	STRAPPING ON ANALOG BOARD (JB1 CP) INSTALL RED STRAPS	STRAPPING ON DIGITAL BOARD (JB2 CP) INSTALL RED STRAPS	REMOVE RED STRAPS FOR OPTION	PROVIDE
New Sync	Not Used	YA		20-21	YB	One Per Station
	Customer- Controlled	YB		19-20	YA	
Transmitter Timing	INT	YC			YD	One Per Station
	EXT	YD		13-14		
Automatic Answer	RDY and DTR Control or Not Provided	YE			YF	One Per Station
	DTR Control Only	YF		17-18		
Ring Indication On Customer Interface	EIA	YG		22-24	YH	One Per Station
	Contact	YH		22-23	YG	
Use With DAS 828-Type	Yes	YI			YJ	One Per Station
	No	YJ		15-16		
Grounding Option	Common	YK		25-26		One Per Station
	Not Common	YL			YK	
Type of Operation and Clear- to-Send Delay	4-Wire PL	XA	35-36	1-3, 4-6, 28-29, 11-12	Note 1	One Per Station
		XB	35-36	1-3, 5-6, 28-29, 11-12	Note 2	
		XC	35-36	2-3, 5-6, 28-29, 11-12	Note 3	
	2-Wire DDD	XD	4-5	1-3, 4-6, 27-28	Note 4	
	2-Wire PL	XE	4-5, 35-36	1-3, 4-6, 133-134, 11-12	Note 5	

* DO NOT REMOVE ANY BLACK TEST STRAPS.

† Use option ZS for all installations.

Note 1: Remove red straps: 4-5 on JB1 CP; 2-3, 5-6, 27-28, 133-134 on JB2 CP

Note 2: Remove red straps: 4-5 on JB1 CP; 2-3, 4-6, 27-28, 133-134 on JB2 CP

Note 3: Remove red straps: 4-5 on JB1 CP; 1-3, 4-6, 27-28, 133-134 on JB2 CP

Note 4: Remove red straps: 35-36 on JB1 CP; 2-3, 5-6, 28-29, 11-12, 133, 134 on JB2 CP

Note 5: Remove red straps: 2-3, 5-6, 27-28, 28-29 on JB2 CP



ASSOCIATED TELEPHONE
(When Required)

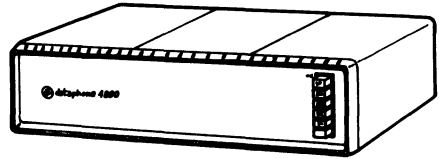

DATA SET 208A-L1A

TABLE I
DATA SET 208A-TYPE OPTIONS

FEATURE OR OPTION		SWITCH*	SWITCH POSITION	OPTION DESIG.
DSR ON in AL Mode		S1A	Up	YM
DSR OFF in AL Mode		(See Note)	Down	YN
No Comp Equalizer Test		S1B	Up	YQ
Comp Equalizer Test Enabled		(See Note)	Down	YR
Continuous Request-to-Send		S1C	Up	YS
Switched Request-to-Send			Down	YT
EQUALIZATION	No Equalization	S2A† S2B† S2C	Down	ZT
	Amp and Delay (Sym) ‡	S2A† S2B S2C	Up Up	ZS
	Amp and Delay (Hi End)	S2A S2B S2C	Up Down Up	ZU
	Amp and Delay (Sym + Hi End)	S2A S2B S2C	Down Down Up	ZV
Transmit Externally Timed		S3A	Up	YD
Transmit Internally Timed			Down	YC
Retrain Automatically §		S3B	Up	YU
Retrain Not Used			Down	YV
DAS is Used		S3C	Up	YI
DAS Not Used			Down	YJ
1-Sec Holdover Disable		S4A	Up	YW
1-Sec Holdover			Down	YX
Continuous Carrier		S4B	Up	XB
Switched Carrier			Down	XA
New Sync Used by Customer		S4C	Up	YB
New Sync Not Used by Customer			Down	YA

† Switch may be in either position.

‡ Always use when optioned for continuous carrier operation (S4B up).

§ This option must always be installed.

Note: This option is not available on DS 208A-L1.

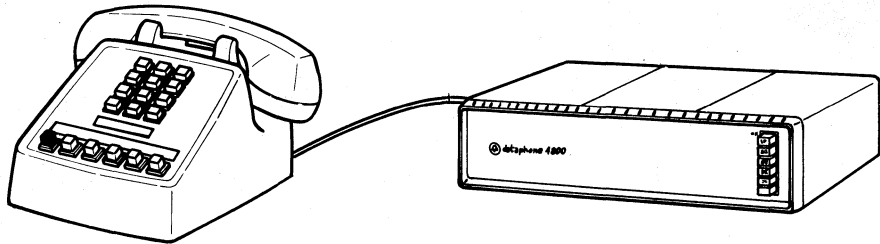

ASSOCIATED TELEPHONE

DATA SET 208B-L1

TABLE J

DATA SET 208B-TYPE OPTIONS

FEATURE	OPTION	SWITCH								"50" BUTTON
		S1A	S1B	S1C	S2A	S2C	S3A	S3B	S3C	
Transmit Line Signal Level	0 dBm ZA*	Down	Up	Down	Up	—	—	—	—	—
	-1 dBm ZB	Down	Up	Down	Down	—	—	—	—	—
	-2 dBm ZC	Down	Up	Up	Up	—	—	—	—	—
	-3 dBm ZD	Down	Up	Up	Down	—	—	—	—	—
	-4 dBm ZE	Down	Down	Down	Up	—	—	—	—	—
	-5 dBm ZF	Down	Down	Down	Down	—	—	—	—	—
	-6 dBm ZG	Down	Down	Down	Up	—	—	—	—	—
	-7 dBm ZH	Down	Down	Up	Down	—	—	—	—	—
	-8 dBm ZI	Up	Up	Down	Up	—	—	—	—	—
	-9 dBm ZJ	Up	Up	Down	Down	—	—	—	—	—
	-10 dBm ZK	Up	Up	Up	Up	—	—	—	—	—
	-11 dBm ZL	Up	Up	Up	Down	—	—	—	—	—
	-12 dBm ZM	Up	Down	Down	Up	—	—	—	—	—
	-13 dBm ZN	Up	Down	Down	Down	—	—	—	—	—
	-14 dBm ZO	Up	Down	Up	Up	—	—	—	—	—
-15 dBm ZP	Up	Down	Up	Down	—	—	—	—	—	
Compromise Equalizer †	IN ZS*	—	—	—	—	Up	—	—	—	—
	OUT ZT	—	—	—	—	Down	—	—	—	—
DSR in Analog Loop Mode	ON YM	—	—	—	—	—	Up	—	—	—
	OFF YN*	—	—	—	—	—	Down	—	—	—
Answer	MAN. YO	—	—	—	—	—	—	Up	—	—
	AUTO YP*	—	—	—	—	—	—	Down	—	—
Transmitter Timed	EXT. YD	—	—	—	—	—	—	—	Up	—
	INT. YC*	—	—	—	—	—	—	—	Down	—
RS-CS Interval++	50 MS	—	—	—	—	—	—	—	—	Depressed
	150 MS	—	—	—	—	—	—	—	—	Released

*Factory installed.

†Compromise Equalizer should always be in.

++ If not specified on service order; install 50 msec. interval.

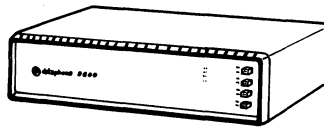

DATA SET 209A-L1

TABLE K

DATA SET 209A-L1 OPTIONS

OPTION†	REMOVE SWITCH	JACK POSITION	INSTALL SWITCH	JACK POSITION	FEATURE	PROVIDE
WA	S3	4	S2	1	Elastic Store Enable 1 IN	One Per Station
WB*	S2	1	S3	4	Elastic Store Enable 1 OUT	
WC	S3	6	S2	3	Elastic Store Enable 2 IN	One Per Station
WD*	S2	3	S3	6	Elastic Store Enable 2 OUT	
WE	S2	4	S2	5	Elastic Store Enable 3 IN	One Per Station
WF*	S2	5	S2	4	Elastic Store Enable 3 OUT	
WG	S2	8	S2	7	Elastic Store Enable 4 IN	One Per Station
WH	S2	7	S2	8	Elastic Store Enable 4 OUT	
VI	S6	4	S6	5	Slave IN	One Per Station
WJ*	S6	5	S6	4	Slave OUT	
WK*	S1	5	S1	4	Compromise Equalizer Receive Slope IN	One Per Station
WL	S1	4	S1	5	Compromise Equalizer Receive Slope OUT	
WM	S1	2 or 3	S1	1	Compromise Equalizer Receive Phase HI	One Per Station
WN*	S1	1 or 3	S1	2	Compromise Equalizer Receive Phase OUT	
WO	S1	1 or 2	S1	3	Compromise Equalizer Receive Phase LO	
WP*	S3	3	S3	1	Compromise Equalizer Trmtr Slope IN	One Per Station
WQ	S3	1	S3	3	Compromise Equalizer Trmtr Slope OUT	
WR	S1	7 or 8	S1	6	Compromise Equalizer Trmtr Phase HI	One Per Station
WS*	S1	6 or 8	S1	7	Compromise Equalizer Trmtr Phase OUT	
WT	S1	6 or 7	S1	8	Compromise Equalizer Trmtr Phase LO	
XF	S5	6 or 7 or 8	S5	3	4W Switched Carrier and Auto Retrain	One Per Station
XG*	S5	3 or 7 or 8	S5	6	4W Continuous Carrier and Auto Retrain	
XH	S5	3 or 6 or 8	S5	7	4W Switched Carrier and No Auto Retrain	
XI	S5	3 or 6 or 7	S5	8	4W Continuous RS and Auto Retrain	
YC*	S6	3	S6	2	Internal Timing	One Per Station
YD	S6	2	S6	3	External Timing	
YI*	S3	8	S6	6	DAS #28- or #29-type Used	One Per Station
YJ	S6	6	S3	8	DAS #28- or #29-type Not Used	
YM	S6	8	S5	1	DSR ON in Analog Loop Mode	One Per Station
YN*	S5	1	S6	8	DSR OFF in Analog Loop Mode	
YW	S5	5	S5	4	1-Second Holdover OUT	One Per Station
YX*	S5	4	S5	5	1-Second Holdover IN	

* Factory installed.

† If this data set is the first data set 209A-L1 to be installed in the system, options WK, WN, WP, and WS must be installed.

7. FINAL ASSEMBLY

7.01 Opcon Assembly for Tabletop Arrangements (Fig. 28):

- (a) Plug connector P40 (406192 cable assembly) into 40K003/AAB Opcon.
- (b) Push opcon ground strap terminal onto cabinet terminal tab.
- (c) Slide left or right latches down.
- (d) Engage left and right guides into slots.
- (e) Slide left and right latches upward into latched position.

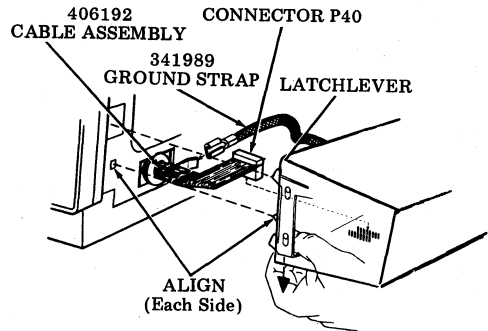

Fig. 28—Opcon Assembly

Warning: Check that opcon is firmly attached on both sides before releasing hold.

Note: The opcon for the forms access arrangements is mounted on the front panel of the cabinet.

7.02 Controller Assembly (Fig. 29) (if controller is removed for reoptioning):

Warning: Take the proper ground precautions when handling the integrated controller, as discussed in 1.03.

- (a) Remount the 410734 diode matrix circuit card.
- (b) Replace cover plate with four screws.

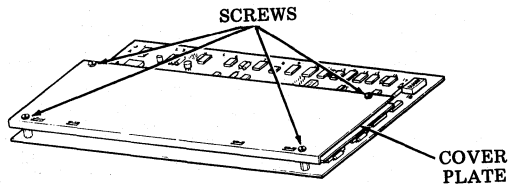

Fig. 29—40C303AC/003 Controller Assembly

7.03 Assembly of Controller Into Cabinet

Table Mounted Cabinet

- (a) Located controller in bottom of cabinet. Use EIA cable connector as a reference.
- (b) Plug in P3 (EIA), P5 (SSI), P21 (Power) and P6 (Opcon) connectors.

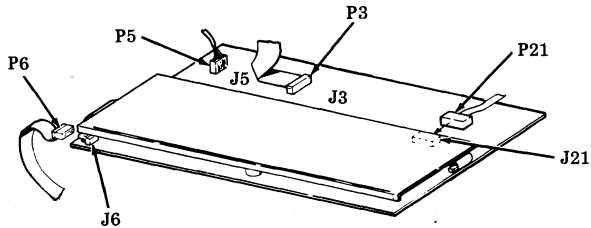

Fig. 30-40C303AC/003 Cable Connections

- (c) Push controller against capacitor bracket so that rubber isolators prevent controller from moving freely. Rubber isolators must not be pushed out of position and the metal around the isolators must not touch the circuit card.
- (d) Replace paper chute. Tighten two nuts securing paper chute.

Forms Access Cabinet

- (a) Locate 40C303AC/003 controller in controller cover. Remount two brackets; secure brackets with four screws (Fig. 31).

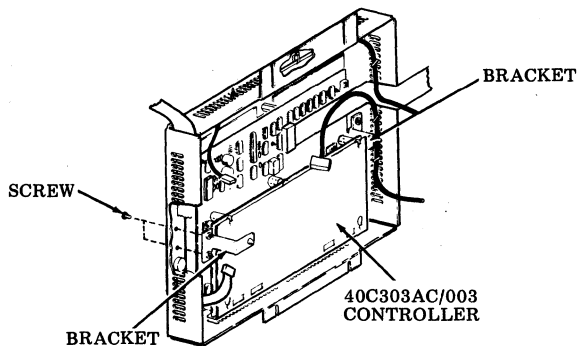

Fig. 31—Assembly of 40C303AC/003 Controller

- (b) Plug in P3 (EIA), P5 (SSI), P6 (Opcon) and P21 (Power) connectors (Fig. 32).

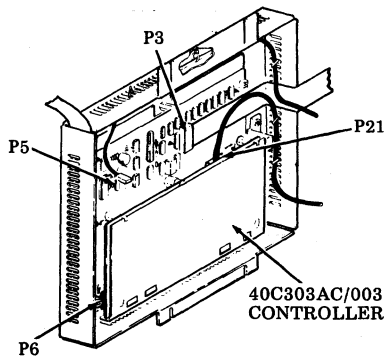

Fig. 32—Controller Connectors

(c) To assemble controller cover with controller to form access cabinet engage upper mounting screws of cabinet in upper (longer) slots of cover; slide cover up to limits of slots and engage lower slots with mounting screws, slide cover down. Tighten four screws (Fig. 33).

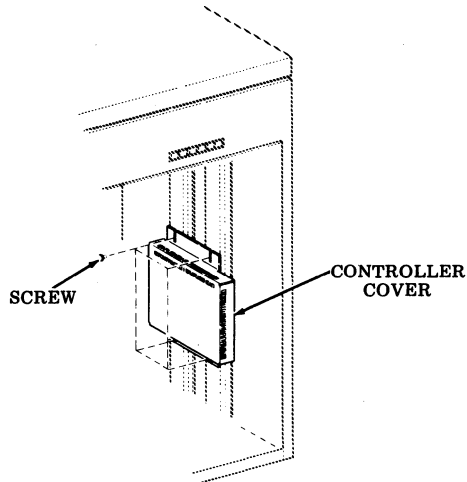

Fig. 33—Controller Assembly

- 7.04 For installation of printer into printer cabinet refer to Section 582-210-200, Issue 3, (plus addendum) or later.
- 7.05 Data Set Connection: After the data set has been optioned, connect to the Integrated ROP Set (Fig. 34, 35, 36).

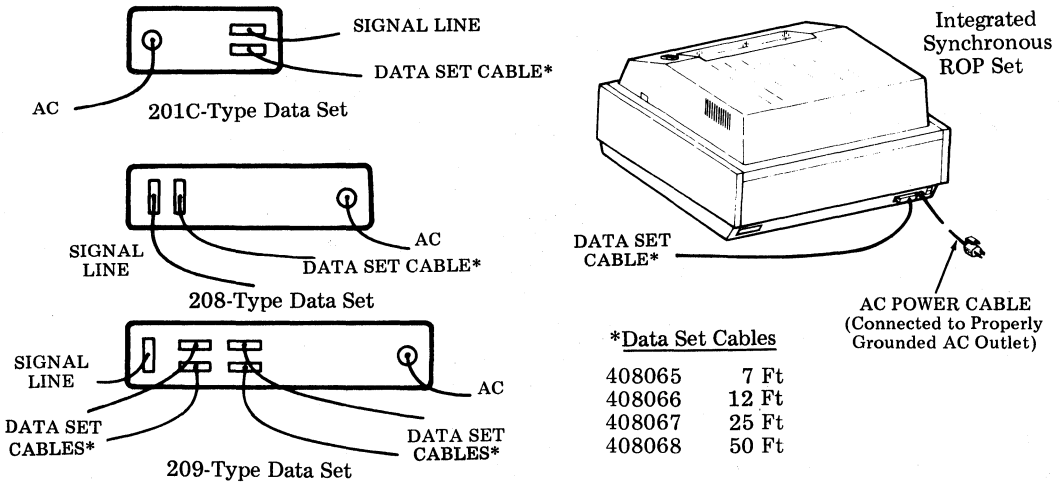

Fig. 34—Data Set Connection — Tabletop Cabinet

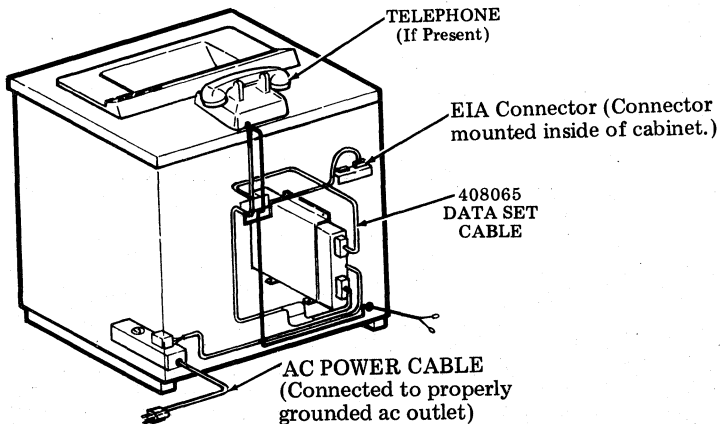

Fig. 35—Data Set Connection -- Forms Access Printer Cabinet (Data Set Internally Mounted)

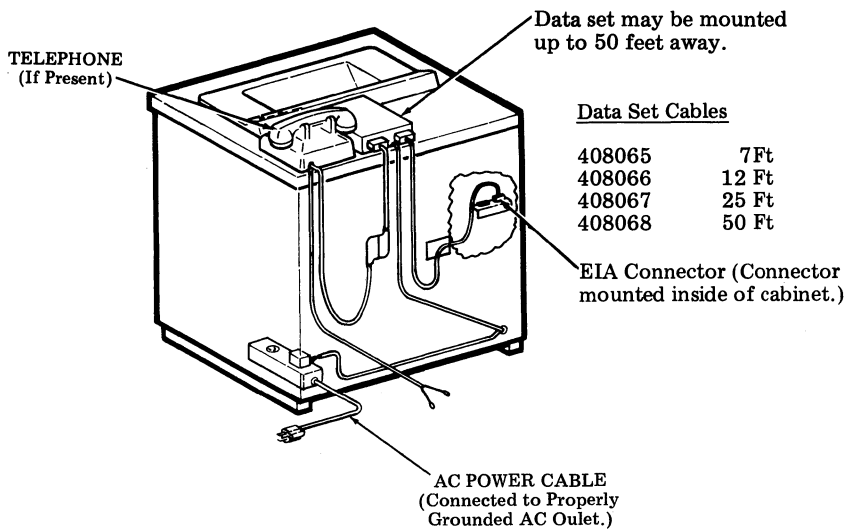

Fig. 36—Data Set Connections — Forms Access Printer Cabinet (Data Set Externally Mounted)

- 7.06 Station Feature and Option Record: A record should be made of all ROP station options installed on BSTSEA W-Plans, W-4OPTR and W-4RPXA. For recording data set options refer to the appropriate data set BSP section. The option record should be associated with the station. It may be placed inside the pedestal if one is present.
- 7.07 Install ribbon and paper following instructions in Section 582-210-200. Make any adjustments for number of plies of paper used, form out belt settings, etc. at this time.
- 7.08 Test the station off-line and on-line per Section 582-202-500.

INTEGRATED SYNCHRONOUS "DATASPEED*" 40 RECEIVE-ONLY PRINTER STATION

WIRING DIAGRAMS

CONTENTS	PAGE	
1. GENERAL	1	CABLE ROUTING FOR FORMS ACCESS CABINET EQUIPPED WITH MODIFICATION KIT 406372 (FOR 40C303AC/003 CONTROLLERS)..... 16
2. WIRING DIAGRAMS	2	408065-408068 DATA SET CABLE 17
INTERCONNECTING DIAGRAM FOR DATASPEED 40 ROP TABLE- TOP TERMINAL WITH INTEGRATED SYNCHRONOUS CONTROLLER ...	2	
INTERCONNECTING DIAGRAM FOR DATASPEED 40 FORMS ACCESS ROP WITH INTEGRATED SYNCHRONOUS CONTROLLER 40C303AC/003 (USOC 4EQS+)	6	1. GENERAL
40P154/ZZ AND 40P253/ZZ 80-COLUMN TRACTOR FEED PRINTER	10	1.01 This section provides simplified schematic wiring diagrams and cable drawings for Integrated Synchronous DATASPEED 40 Receive-Only Printer (ROP) Stations. It is intended to meet the needs of field maintenance personnel. Schematic wiring diagrams for associated data sets are contained in the appropriate BSP sections.
40P202 132-COLUMN TRACTOR FEED PRINTER	12	1.02 This section is reissued to include infor- mation pertaining to FORMS ACCESS arrangements. Since this reissue is a general revi- sion, no revision arrows have been used to denote significant changes.
CABLE ROUTING FOR TABLETOP TRACTOR FEED CABINETS EQUIPPED WITH MODIFICATION KIT 406190 (FOR 40C303AC/003 CONTROLLERS).....	14	<i>Note:</i> When ordering replaceable components, unless otherwise specified, prefix each part number with the letters "TP" (ie, TP410055).

*Registered Trademark of AT&TCo.

2. WIRING DIAGRAMS

INTERCONNECTING DIAGRAM FOR DATASPEED 40 ROP TABLETOP TERMINAL WITH INTEGRATED SYNCHRONOUS CONTROLLER 40C303AC/003 (USOC 4RPX+ (80 Column) OR USOC 4RRX+ (132 Column)) (Continued on Pages 3 and 4)

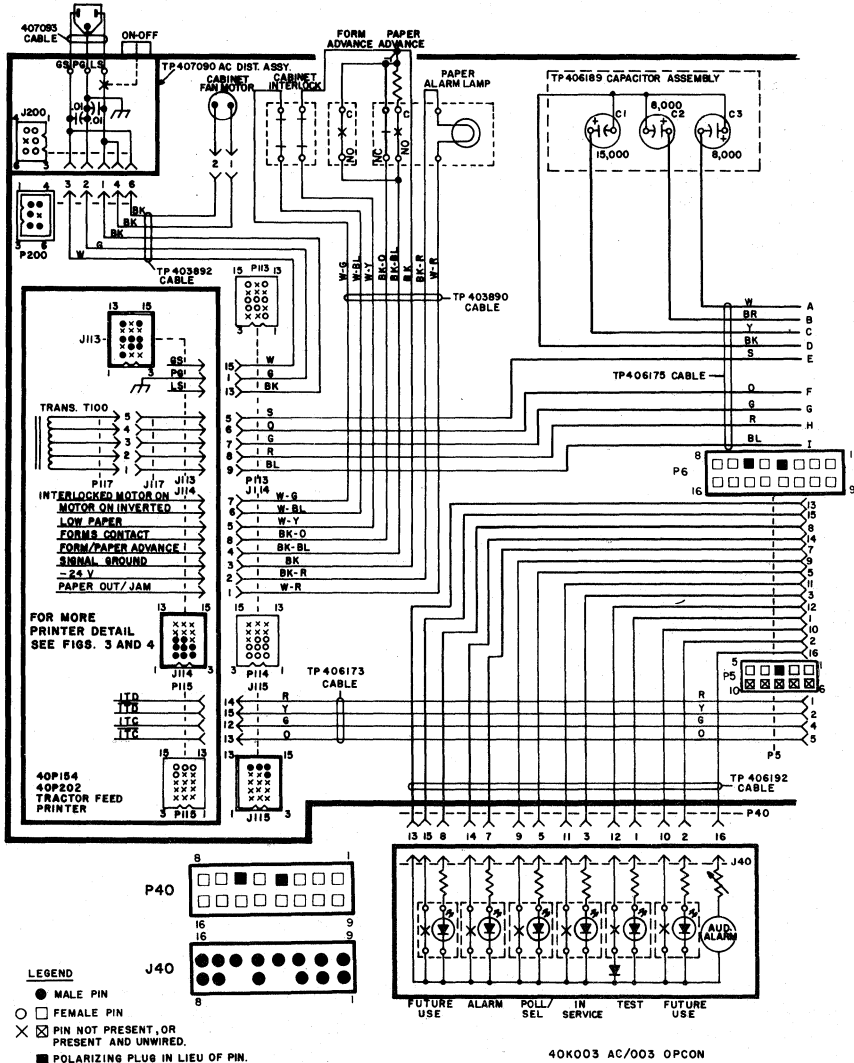

Fig. 1

INTERCONNECTING DIAGRAM FOR DATASPEED 40 ROP TABLETOP TERMINAL WITH INTEGRATED SYNCHRONOUS CONTROLLER 40C303AC/003 (USOC 4RPX+ (80 Column) OR USOC 4RRX+ (132 Column)) (Cont)

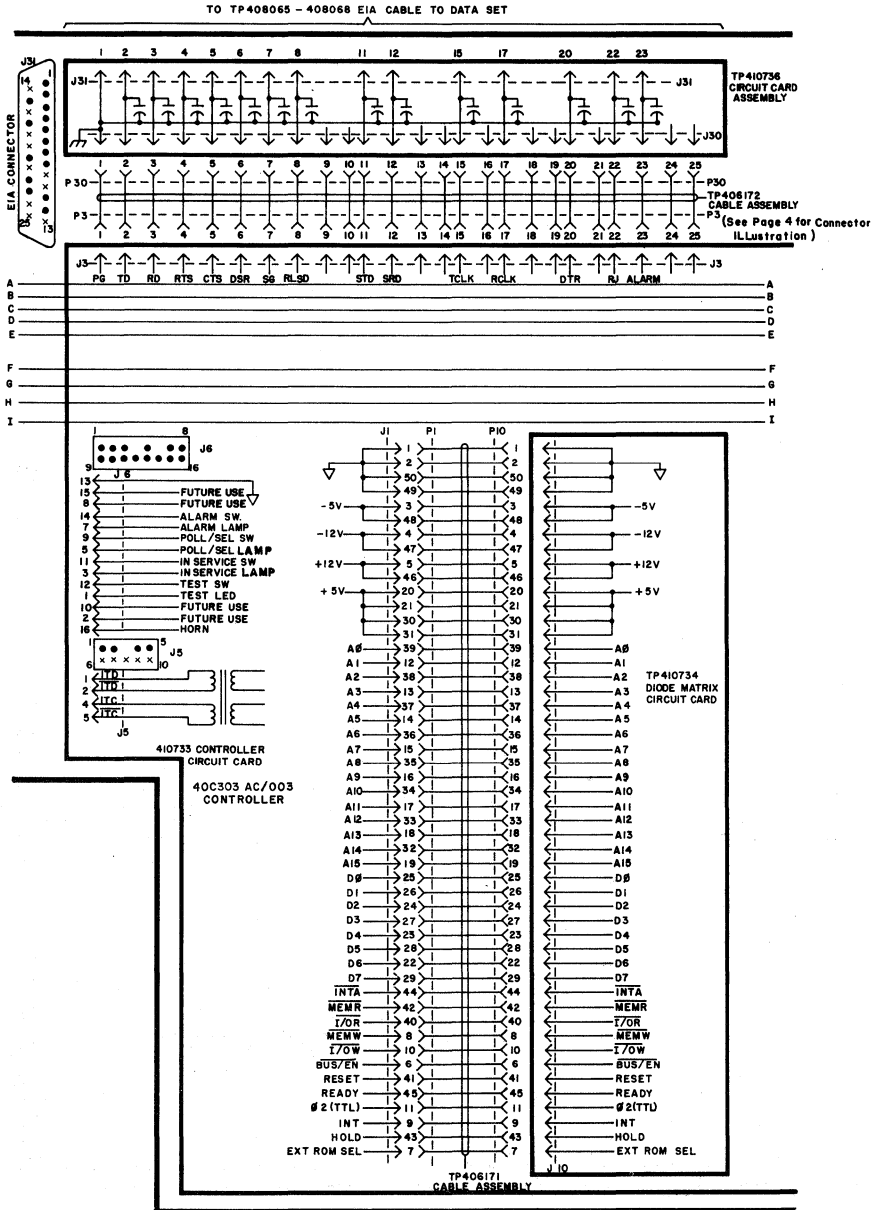

Fig. 1 (Cont)

INTERCONNECTING DIAGRAM FOR DATASPEED 40 ROP TABLETOP TERMINAL WITH INTEGRATED SYNCHRONOUS CONTROLLER 40C303AC/003 (USOC 4RPX+ (80 Column) OR USOC 4RRX+ (132 Column)) (Cont)

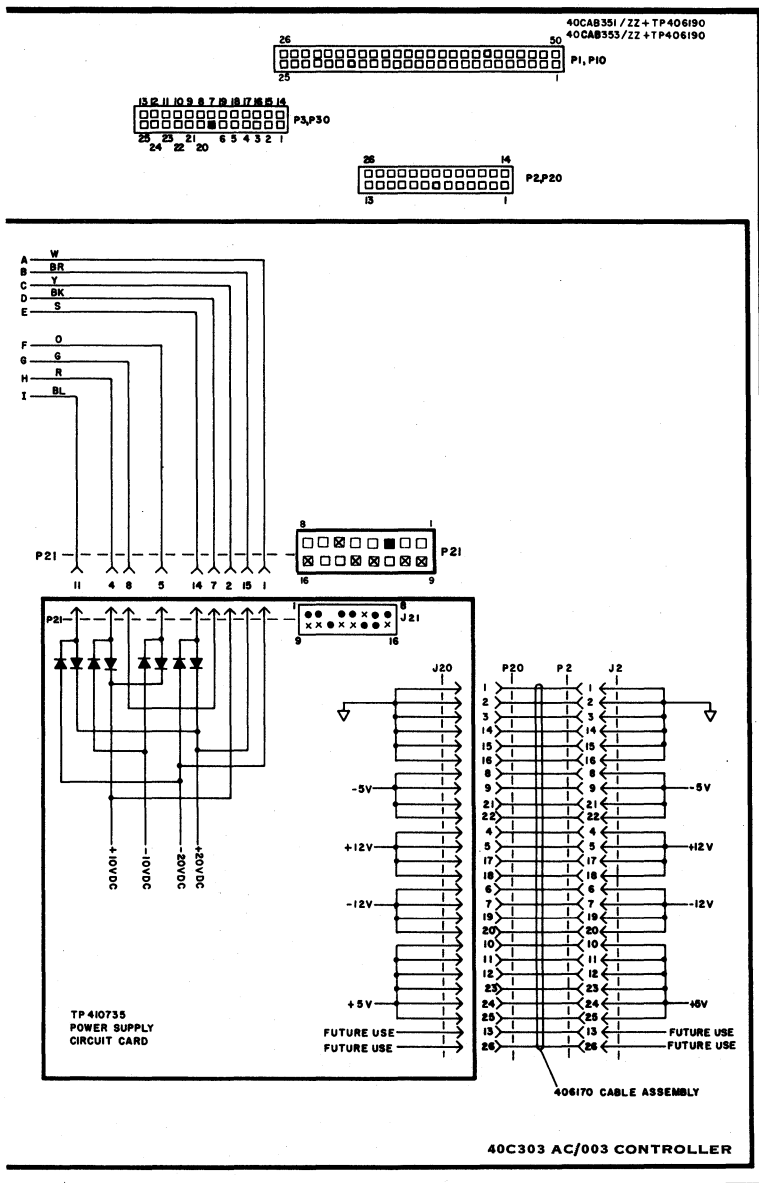

Fig. 1 (Cont)

INTERCONNECTING DIAGRAM FOR DATASPEED 40 FORMS ACCESS ROP WITH INTEGRATED SYNCHRONOUS CONTROLLER 40C303AC/003 (USOC 4EQS+) (Continued on Pages 7/8 and 9.)

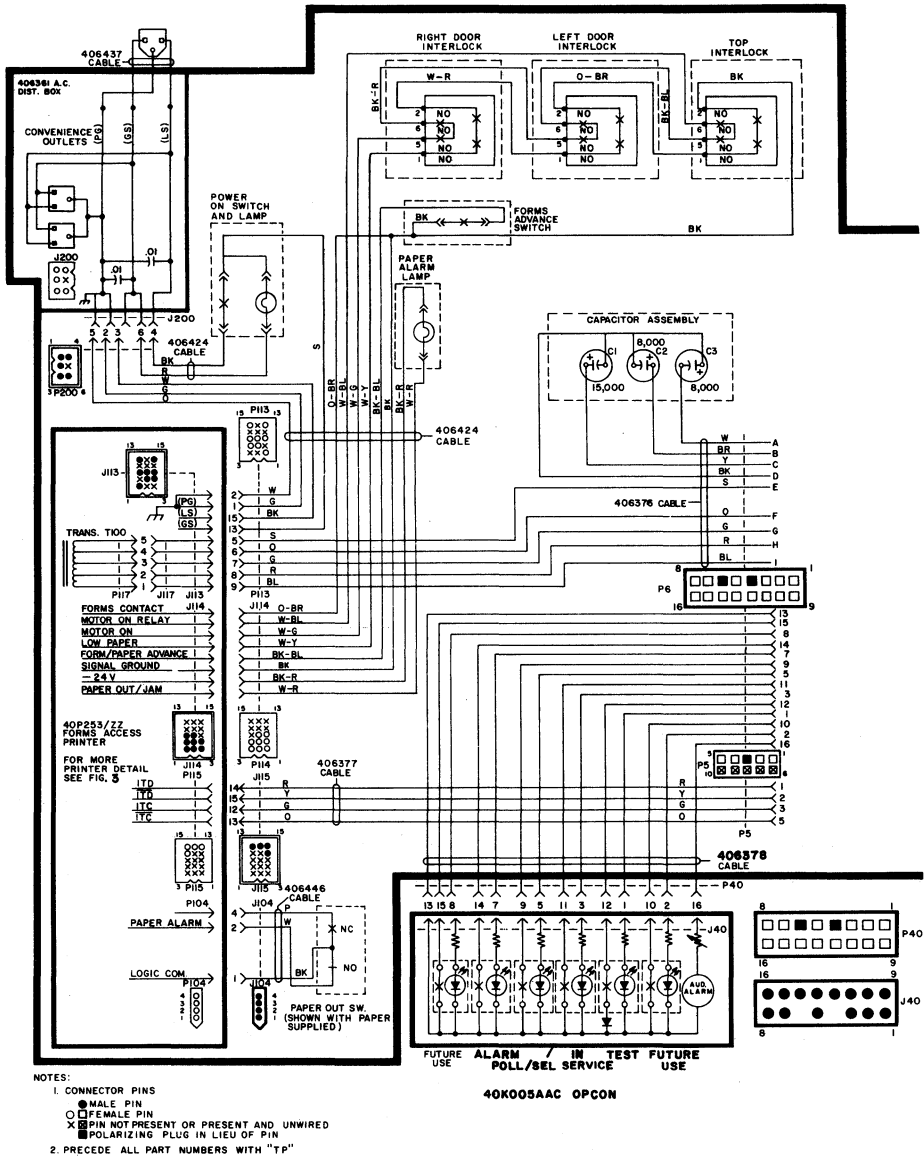

Fig. 2

INTERCONNECTING DIAGRAM FOR DATASPEED 40 FORMS ACCESS ROP WITH INTEGRATED SYNCHRONOUS CONTROLLER 40C303AC/003 (USOC 4EQS+) (Cont)

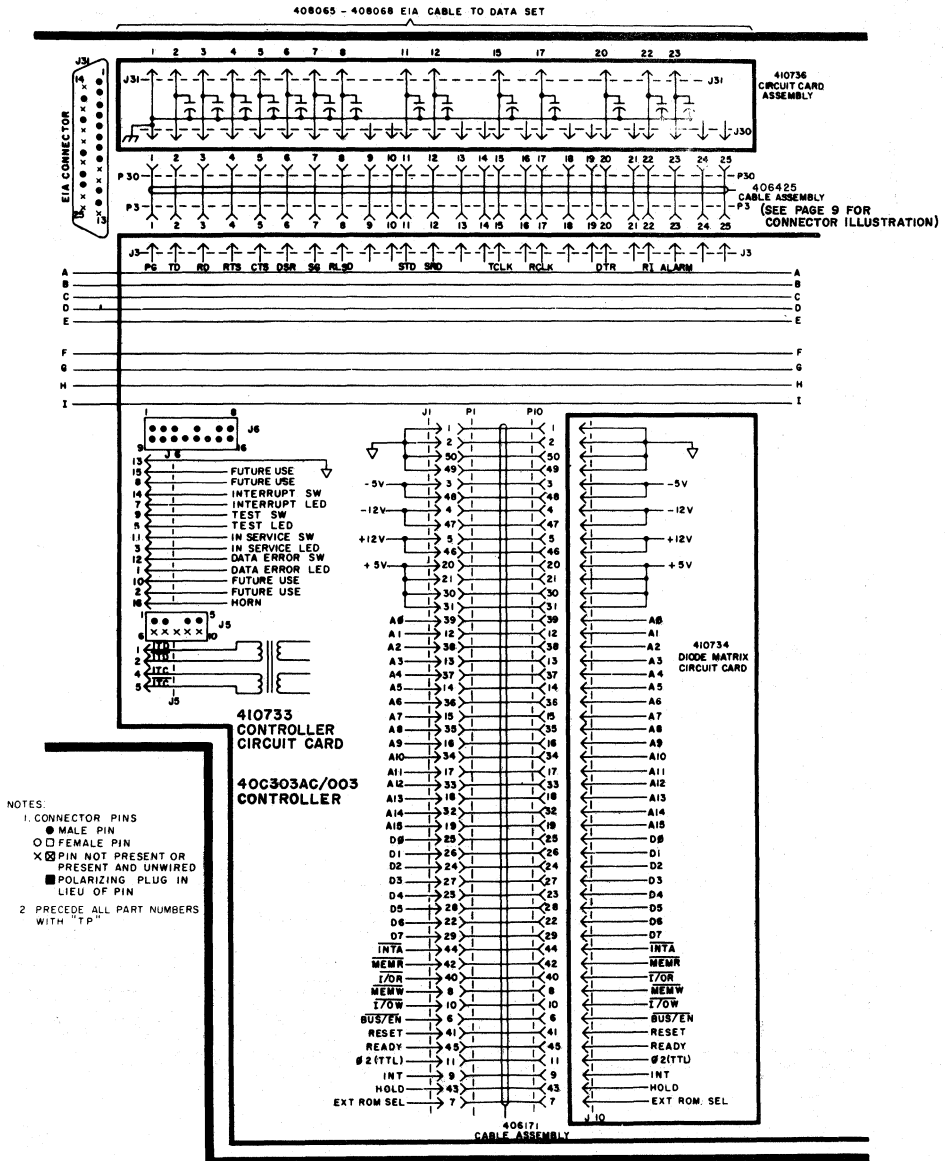

Fig. 2 (Cont)

INTERCONNECTING DIAGRAM FOR DATASPEED 40 FORMS ACCESS ROP WITH INTEGRATED SYNCHRONOUS CONTROLLER 40C303AC/003 (USOC 4EQS+) (Cont)

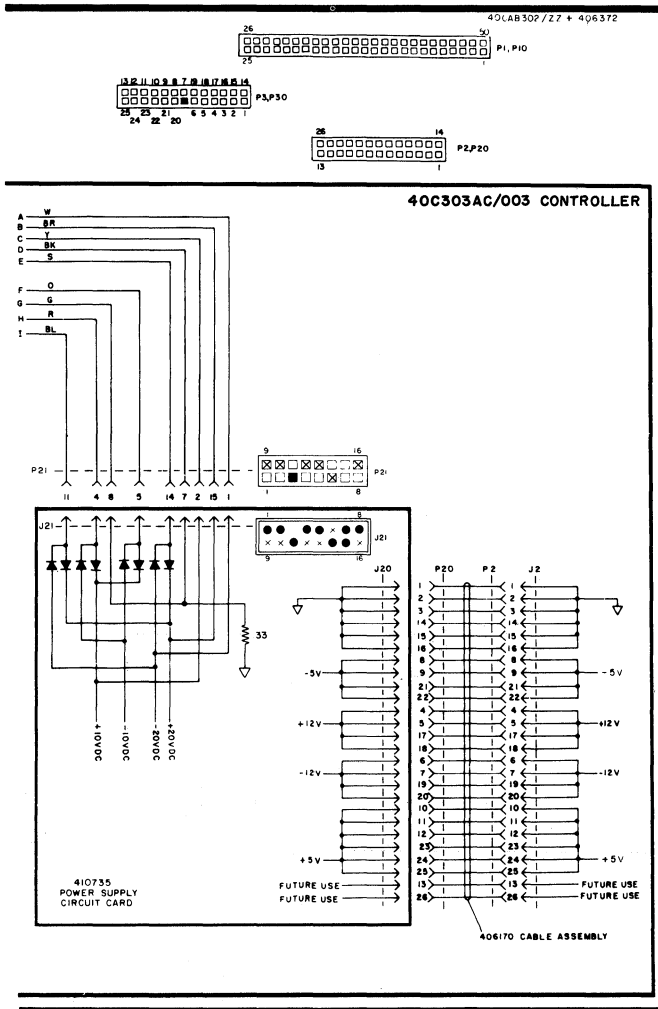
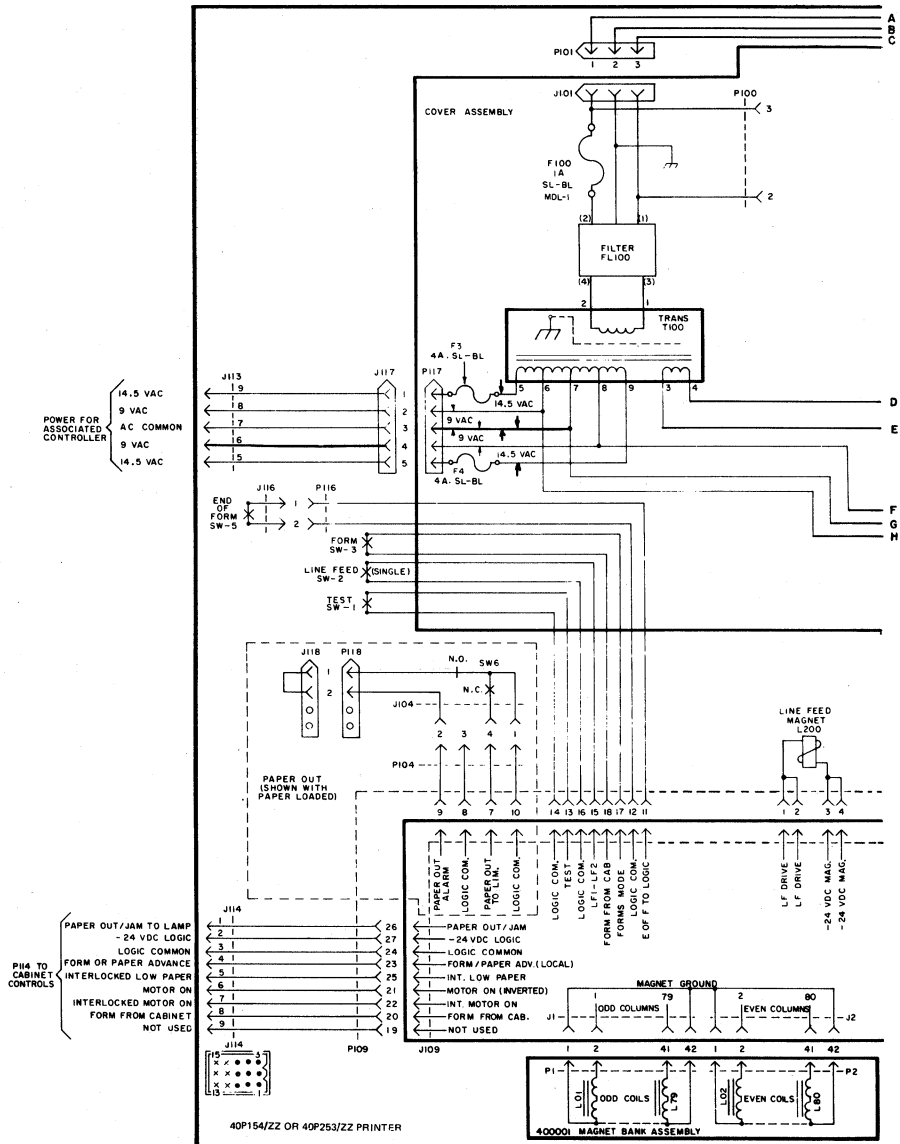

Fig. 2 (Cont)

40P154/ZZ AND 40P253/ZZ 80-COLUMN TRACTOR FEED PRINTER



Note: Grounding Option — Inserting Option Screw A on component side of 410151 circuit card connects -24 V dc circuit common to chassis. Inserting Option Screw B on component side of 410151 circuit card connects -24 V dc circuit common to +11.3 V dc circuit common. Inserting Option Screw A or B into noncomponent side of card leaves connection open. Refer to Option 61.

Fig. 3

40P154/ZZ AND 40P253/ZZ 80-COLUMN TRACTOR FEED PRINTER (Cont)

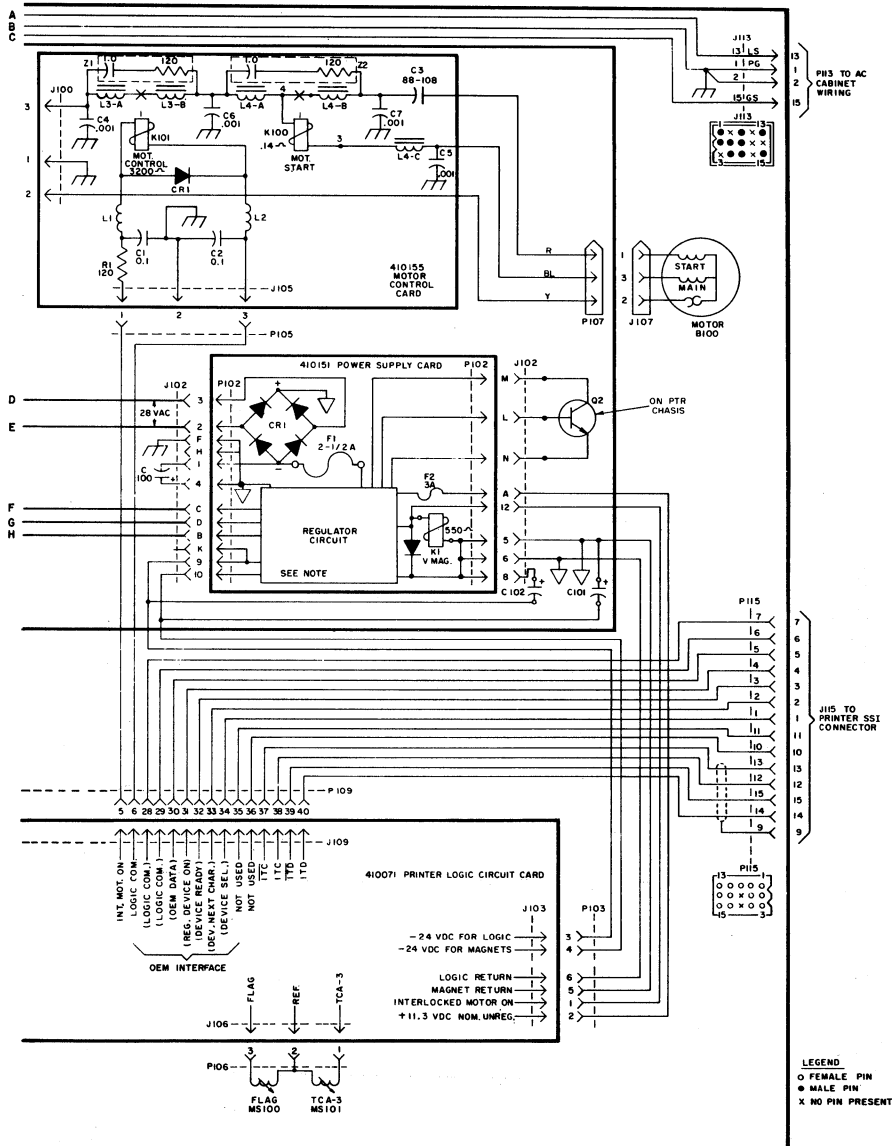
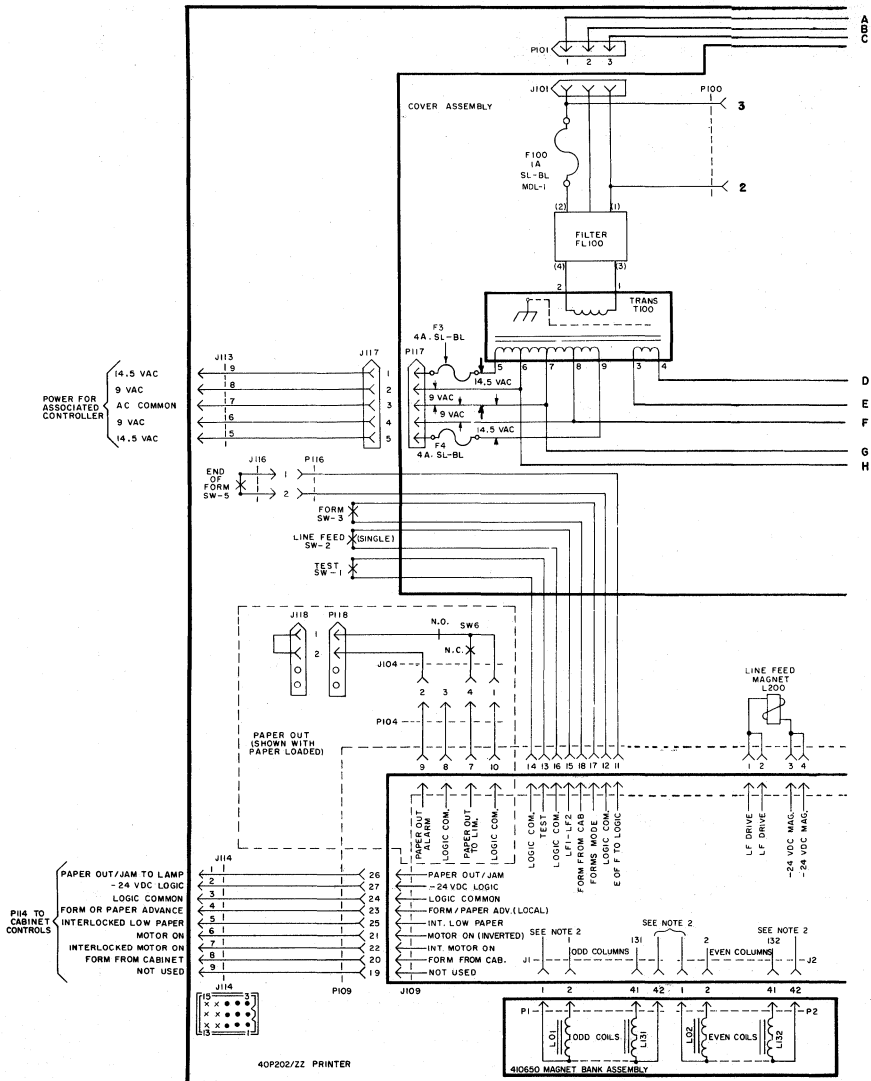

Fig. 3 (Cont)

40P202/ZZ 132-COLUMN TRACTOR FEED PRINTER



Note 1: Grounding Option — Inserting Option Screw A on component side of 410151 circuit card connects -24 V dc circuit common to chassis. Inserting Option Screw B on component side of 410151 circuit card connects -24 V dc circuit common to +11.3 V dc circuit common. Inserting either screw into noncomponent side of card leaves connection open.

Note 2: Pins 1 and 68 of the 410650 magnet bank assemblies will be connected to magnet ground.

Fig. 4

40P202/ZZ 132-COLUMN TRACTOR FEED PRINTER (Cont)

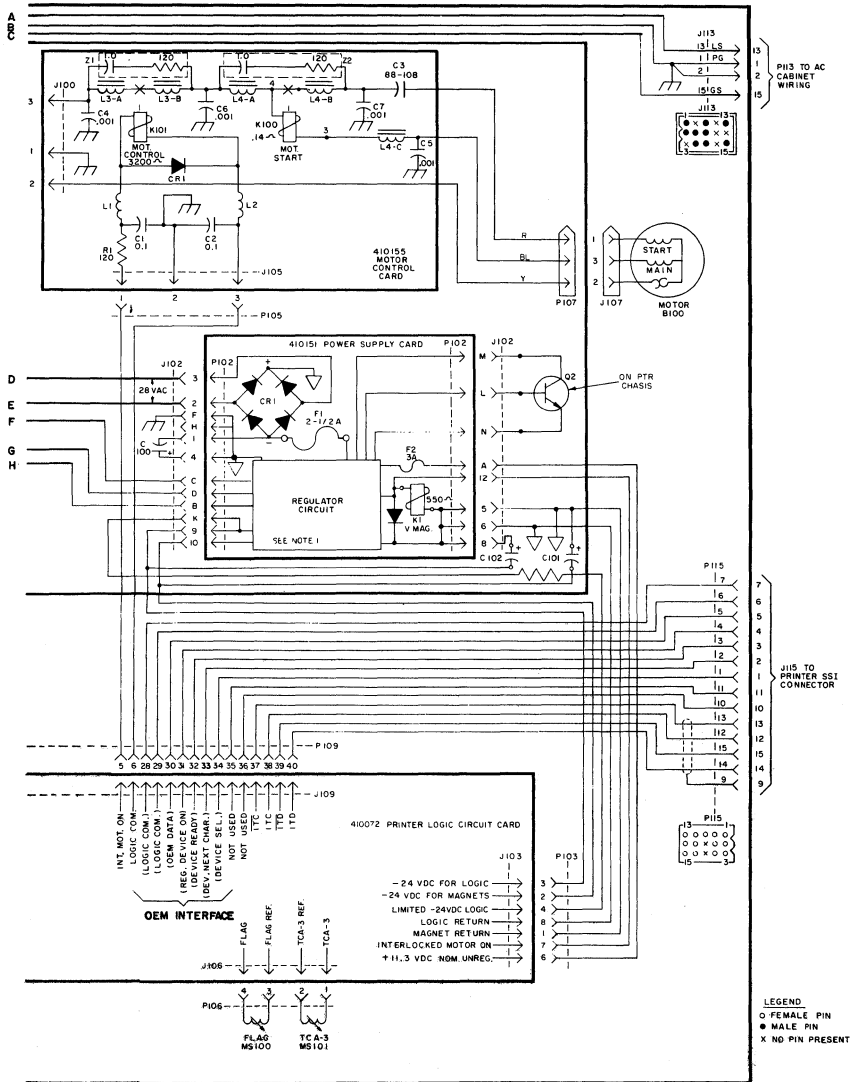
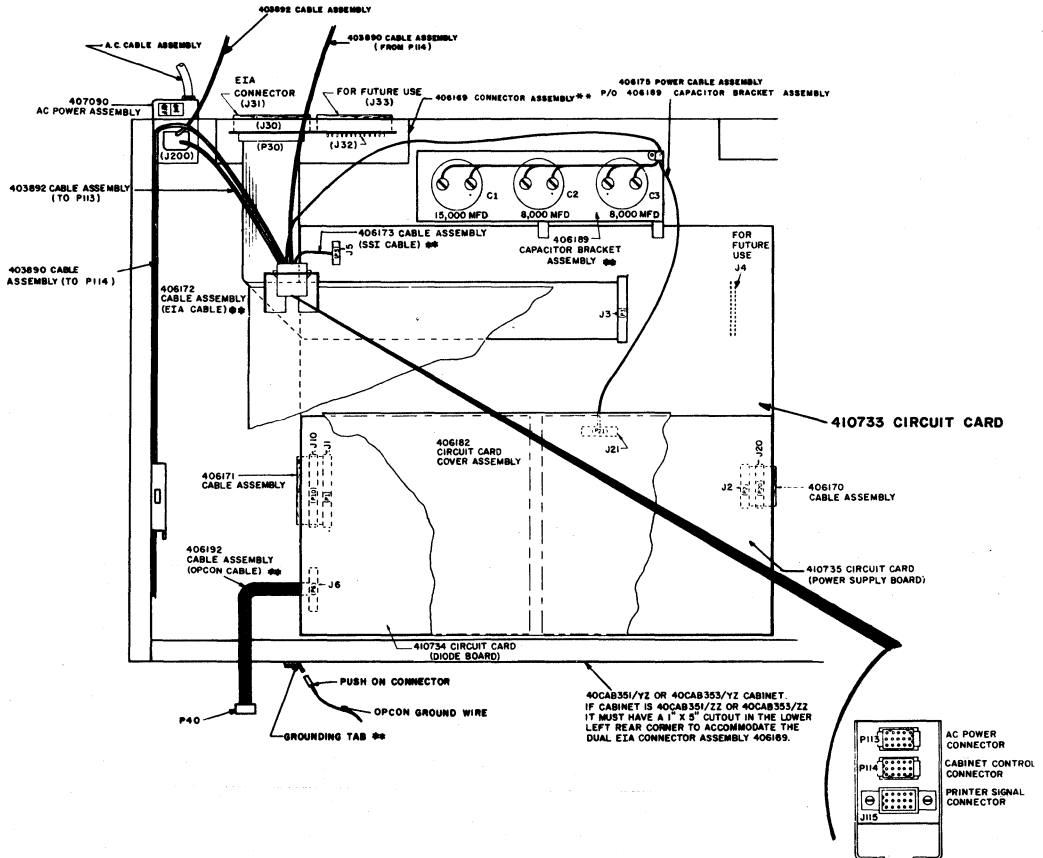

Fig. 4 (Cont)

CABLE ROUTING FOR TABLETOP TRACTOR FEED CABINETS EQUIPPED WITH MODIFICATION KIT 406190 (FOR 40C303AC/003 CONTROLLERS)



Note: Parts marked with a (**) are part of Modification Kit 405190.

(View of Cabinet Base)

Fig. 5

CABLE ROUTING FOR TABLETOP TRACTOR FEED CABINETS EQUIPPED WITH MODIFICATION KIT 406190 (FOR 40C303AC/003 CONTROLLERS) (Cont)

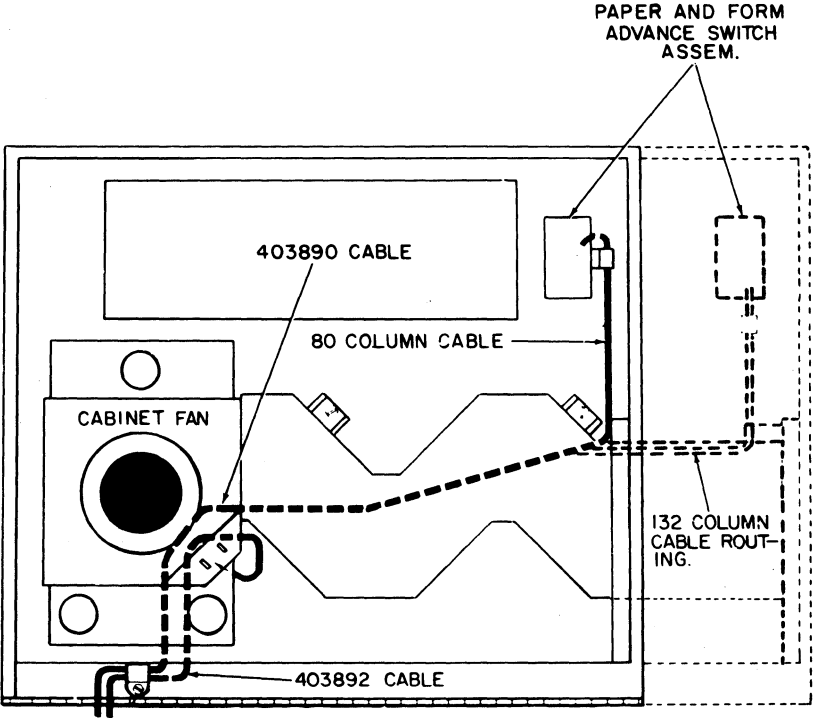

(View Of Cabinet Cover)

Fig. 5 (Cont)

**CABLE ROUTING FOR FORMS ACCESS CABINET EQUIPPED WITH MODIFICATION KIT 406372
(FOR 40C303AC/003 CONTROLLERS)**

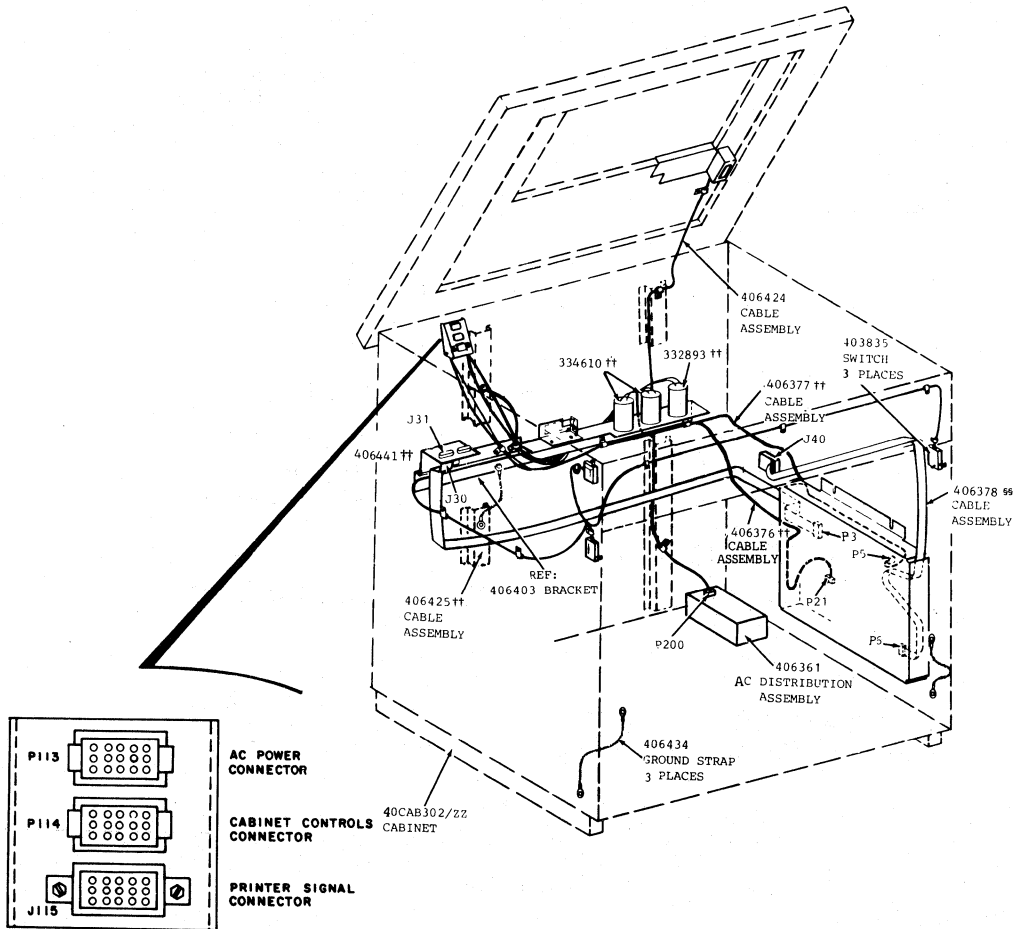

Note 1: Parts marked with a (††) are part of Modification Kit 406372.
Note 2: Parts marked with a (§§) are part of Operator Console 40K005AAC.

Fig. 6

408065-408068 DATA SET CABLE

341977 Connector		341978 Connector
1	OUTER DRAIN WIRE	1
2	BR	2
3	R	3
4	O	4
5	Y	5
6	G	6
7	INNER DRAIN WIRE	7
8	P	8
11	S	11
12	W-G	12
15	BK	15
17	W-BR	17
20	W-R	20
22	W-O	22
23	W-Y	23
25	BL	25

ACTUAL WIRING

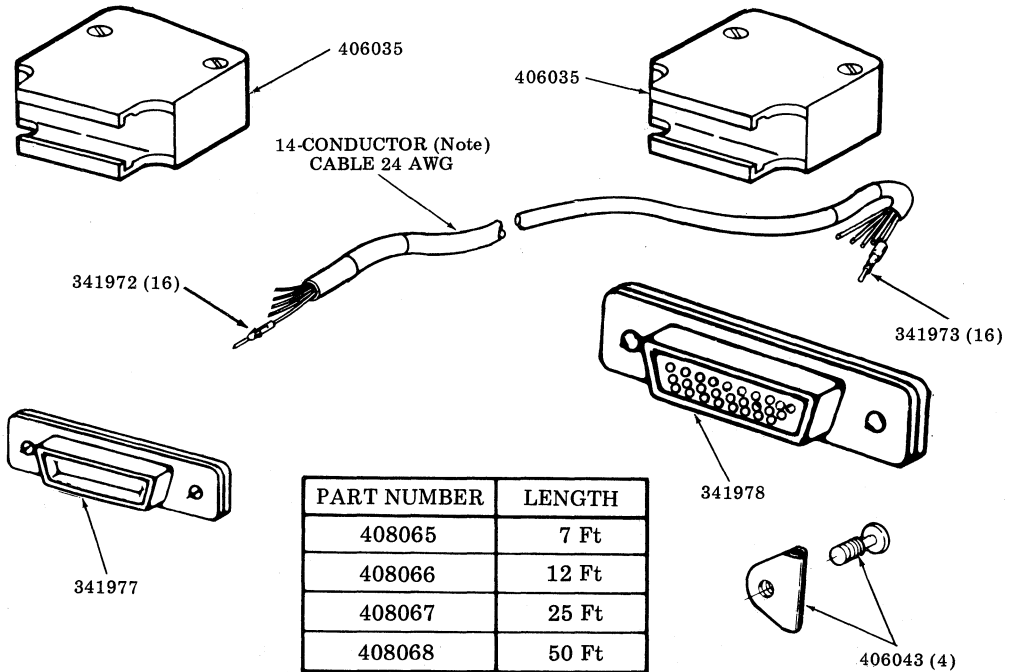

Note: Number of conductors does not include inner or outer drain shields.

INTEGRATED SYNCHRONOUS "DATASPEED*" 40 RECEIVE-ONLY PRINTER STATION
TESTING AND TROUBLESHOOTING

CONTENTS	PAGE	1. GENERAL
1. GENERAL	1	1.01 This section provides procedures for off-line and on-line testing, and all troubleshooting of Integrated Synchronous DATASPEED 40, hereafter referred to as 40-type, Receive-Only Printer (ROP) Stations in switched network, point-to-point private line and multipoint private line service.
2. OPERATIONAL CHECKOUT	1	
GENERAL	1	
PRELIMINARY CHECKS	2	
OFF-LINE CHECKOUT	2	1.02 This section is reissued to include information pertaining to forms access arrangements and printer and cabinet section reference numbers for troubleshooting. Since this reissue is a general revision, no revision arrows have been used to denote significant changes.
ON-LINE CHECKOUT — SWITCHED NETWORK SERVICE	2	
ON-LINE CHECKOUT — POINT-TO-POINT AND MULTIPOINT PRIVATE LINE SERVICE	2	1.03 Troubles isolated to the data set, telephone lines, or associated systems are not analyzed in this section.
DATA SET CHECKOUT	2	
END-TO-END INSTALLATION TEST	7	<i>Note:</i> When ordering replaceable components, unless otherwise specified, prefix each part number with the letters "TP" (ie, TP410733).
CHECKOUT OF RECEIVED PRINTER MESSAGE	11	
3. TROUBLESHOOTING	13	2. OPERATIONAL CHECKOUT
GENERAL	13	GENERAL
TERMINAL ANALYSIS	14	2.01 An operational checkout should be performed after installation or on trouble calls. On maintenance or trouble calls at a location, confine the checkout to the specified trouble area. Perform a complete checkout after an extensive repair.
COMPONENT ANALYSIS	16	
A. Integrated Synchronous Controller	16	2.02 The checkout routines are presented in tables. Each table covers a particular checkout, depending on the type of station.
B. Operator Console (Opcon)	18	

*Registered Trademark of AT&TCo.

2.03 If the indicated response is not obtained in any step of a checkout procedure, repeat the step to make sure that the procedure has been performed correctly. If the results are still unsatisfactory, perform the indicated trouble analysis. Always perform the checkout in the order given in the table. The trouble analysis steps are based on satisfactory results of all previous steps.

PRELIMINARY CHECK

2.04 Before turning on the equipment, check the following:

- (a) Is station connected to a properly grounded ac service?
- (b) Are all cable connectors fully seated?
- (c) Is cabinet lid closed?
- (d) Are printer paper and ribbon properly installed?

2.05 In addition to the above, check the wiring plan to determine the options and features present in the station. In cases where the results are affected by options, alternate results for each option are provided in the table.

OFF-LINE CHECKOUT

2.06 Off-line checkout (Table A) provides a check of the operating condition of the Integrated Synchronous ROP Terminal. The off-line checkout should be performed before attempting any on-line procedures.

ON-LINE CHECKOUT — SWITCHED NETWORK SERVICE

2.07 On-line checkout for switched network stations is performed between the station under test and a Data Test Center (DTC) equipped with a 40-Type Synchronous Test Set. The DTC

operator controls the checkout using standard test procedures. Table B provides on-line end-to-end checkout procedures.

2.08 When ready for on-line checkout, contact the DTC serving your area.

2.09 When calling a DTC, be prepared to furnish any information requested by the operator as to options and features (type of printer used, selection format, etc). To establish a standard line protocol, the DTC operator will normally request the station under test to hang up and wait for a return call. If an unplanned disconnect occurs at any time during the test, place data set in talk mode, hang up, and wait for the DTC operator to reestablish the call.

ON-LINE CHECKOUT — POINT-TO-POINT AND MULTIPOINT PRIVATE LINE SERVICE

2.10 Preliminary requirements: The data set must pass the data set test requirements.

2.11 On-line checkout for private line stations is performed between the station under test and a Data Test Center (DTC) through a Serving Test Center (STC). The DTC operator controls the checkout using standard test procedures. Table B provides on-line end-to-end checkout procedures.

2.12 Caution should be exercised that valid tests are not omitted.

2.13 In order to perform tests without interference from the line controller (data communications processor), the station under test must be disconnected from the data link to the line controller.

DATA SET CHECKOUT

2.14 At the time of installation or if trouble is suspected in the data set perform the data set checkout according to the appropriate BSP section.

TABLE A
OFF-LINE CHECKOUT

This table checks the basic operation of Integrated Synchronous 40-Type ROP Terminals.

STEP	PROCEDURE	RESULTS	TROUBLE ANALYSIS
1	<p>Preliminary requirement:</p> <p>a. Data set connected.</p> <p>b. Ribbon and paper loaded.</p> <p>c. Switches (top left) set as follows:</p> <p style="padding-left: 20px;">FORMS — ON (Option 39.a.)</p> <p style="padding-left: 20px;">LF — 1 (Option 20.a.)</p> <p style="padding-left: 20px;">Test — Off</p> <p>d. Cabinet cover closed.</p> <p>e. In addition to those options in c. the following printer options must be selected: 17.a., 17.c. (80 column) or 17.e. (132 column), 19.a. or c., 23.b., 57.a., 58.a., 60.b. and 61.c.</p>		
2	Turn power on.	<p>IN SERVICE lamp turns on.</p> <p>Fan moves air in printer cabinet (table top cabinet).</p> <p>Power lamp lights (forms access cabinet).</p>	<p>Integrated Synchronous Controller Analysis — Table E, Page 16.</p> <p>Opcon Analysis — Table F, Page 18.</p> <p>Check:</p> <p>a. PAPER lamp not lit.</p> <p>b. Cabinet Interlock switch is closed.</p> <p>c. Cabinet wiring, Section 582-212-400.</p>
3	Momentarily depress PAPER button (red) on cover of printer cabinet (table top only).	Paper feeds out as long as button is depressed.	<p>Printer Analysis, Section 582-210-500.</p> <p>Check cabinet wiring, Section 582-212-400.</p>

TABLE A (Cont)
OFF-LINE CHECKOUT

STEP	PROCEDURE	RESULTS	TROUBLE ANALYSIS
4	Depress and release FORMS ADVANCE button (black button on cover of table top printer cabinet; red rocker switch on top cover of forms access cabinet).	Paper feeds out until first line of next form is reached, then stops.	Printer Analysis, Section 582-210-500. Check cabinet wiring, Section 582-212-400.
5	Unlatch and raise printer cabinet cover (open doors to forms access printer cabinet).	IN SERVICE lamp extinguishes.	Check cabinet wiring and Interlock switch, Section 582-212-400.
6	Raise cover interlock to maintenance position.	IN SERVICE lamp stays off.	If motor was on when cover was raised, depress IN SERVICE button. Check Interlock switch and cabinet wiring, Section 582-212-400.
7	Momentarily set Test switch to ON position, then return to OFF position.	Printer motor starts. Font identification symbol (such as $\overline{A}^{\overline{A}}$, $\overline{B}^{\overline{B}}$, etc, depending on type carrier) prints repeatedly while switch is on. Single line feed occurs. Motor turns off when switch is returned to off.	Printer Analysis, Section 582-210-500.
8	Depress IN SERVICE button. Tear off next form on perforations (end of form) at bottom of printer cabinet, then slowly roll paper out until last form is fed completely out of printer. Reload forms and close cabinet cover.	IN SERVICE lamp lights. With Option 48.a. PAPER lamp lights and IN SERVICE lamp extinguishes when form is partly through printer. With Option 48.b. PAPER lamp lights when form is partly through printer but IN SERVICE does not extinguish until form out contact closes. The form out contact may be closed by placing the printer Forms switch in the ON position and then depressing the FORMS button/switch on the top of the cabinet. PAPER lamp extinguishes.	Printer Analysis, Section 582-210-500.

TABLE A (Cont)
OFF-LINE CHECKOUT

STEP	PROCEDURE	RESULTS	TROUBLE ANALYSIS
9	<p>Depress TEST button on opcon, then depress again after a few seconds.</p> <p>Depress IN SERVICE button (OFF), depress TEST button on Opcon, then depress IN SERVICE button (ON) after a few seconds.</p>	<p>TEST lamp lights, printer motor starts, and character set is printed repeatedly as shown beginning in column as selected by Options 17, 121 and 131. Lamp extinguishes and printing stops when depressed a second time.</p> <p>Form-out occurs (if Option 39a is selected), feed out occurs (if Options 18b and 39b are selected) or no feed out (if Options 18a and 39b are selected). After TEST lamp is extinguished, printer motor goes off after a delay of approximately 20 seconds. IN SERVICE lamp lights approximately 3 seconds after TEST lamp extinguishes.</p> <p>Form-out occurs (if Option 39a is selected), feed out occurs (if Options 18b and 39b are selected) or no feed out (if Options 18a and 39b are selected). After TEST lamp is extinguished, printer motor goes off after a delay of approximately 20 seconds. IN SERVICE lamp lights approximately 3 seconds after TEST lamp extinguishes.</p> <p>! " # \$ % & ' () * + , - . / 0 1 2 3 4 5 6 7 8 9 : ; < = > ? @ A B C D E F G H I J K L M N O P Q R S T U V W X Y Z [\] ^ _ (for ASCII† Type carrier) ! " # \$ % & ' () * + , - . / 0 1 2 3 4 5 6 7 8 9 : ; < = > ? @ A B C D E F G H I J K L M N O P Q R S T U V W X Y Z - \ _ (for EBCDIC‡ Type carrier) ≡ ≡ ≡ # \$ % & ≡ ≡ ≡ * + , - . / 0 1 2 3 4 5 6 7 8 9 ≡ ≡ ≡ ◇ ≡ ≡ ≡ @ A B C D E F G H I J K L M N O P Q R S T U V W X Y Z ≡ ≡ ≡ ≡ ≡ ≡ ≡ (for 48 character set)</p> <p>TYPE FONT SYMBOL (TYPICAL)</p> <p>Local Test Message Generated by TEST Button (Option 19.a. or c. must be enabled.)</p>	<p>Integrated Synchronous Controller Analysis — Table E, Page 16.</p> <p>If font identification symbol appears, refer to Section 582-202-200 and verify that Option 19.a. or c. is enabled.</p> <p>Integrated Synchronous Controller Analysis — Table E, Page 16.</p>
10	Check printing quality.	<p>Characters should be clearly legible and unbroken on original copy.</p> <p>Note: The TEST message does not check all printing columns.</p>	Printer Analysis, Section 582-210-500.

†American National Standard Code for Information Interchange

‡Extended Binary Coded Decimal Interchange Code.

TABLE A (Cont)
OFF-LINE CHECKOUT

STEP	PROCEDURE	RESULTS	TROUBLE ANALYSIS
11	<p>Raise printer cabinet cover.</p> <p>Set LF switch to position 2.</p> <p>Close cover.</p> <p>Depress TEST button.</p> <p>While printer is printing, raise cover.</p>	<p>IN SERVICE lamp remains off.</p> <p>Repeated character set prints with double line spacing.</p> <p>When cover is raised, printer stops. TEST lamp extinguishes.</p>	<p>Printer Analysis, Section 582-210-500.</p>
12	<p>Restore setting of LF switch (or leave in position 2 if Option 20b required). Set Forms switch to Off (Option 39b).</p> <p>Close cabinet cover.</p> <p>Depress and release FORMS ADVANCE button.</p>	<p>IN SERVICE lamp comes ON.</p> <p>Paper feeds out as long as button is depressed.</p>	<p>Printer Analysis, Section 582-210-500.</p>
13	<p>Tear form off below cabinet.</p> <p>Depress IN SERVICE button (OFF). Depress TEST button (ON).</p>	<p>IN SERVICE lamp extinguishes. TEST lamp lights, TEST message prints.</p> <p>Printing stops when end of form passes Paper-Out switch, PAPER-OUT lamp turns on and TEST lamp extinguishes.</p>	
14	<p>Raise cover and restore setting of Forms switch (or leave in Off position if Option 39b required). Close cabinet cover.</p>		
<p>THIS COMPLETES OFF-LINE CHECKOUT OF INTEGRATED SYNCHRONOUS ROP TERMINALS.</p>			

END-TO-END INSTALLATION TEST

TABLE B
END-TO-END INSTALLATION TEST PROCEDURES

STEP	PROCEDURE	RESULTS	TROUBLE ANALYSIS
1	<p>Preliminary requirements:</p> <p>a. Data set connected.</p> <p>b. Ribbon and paper loaded.</p> <p>c. Switches (top left of printer, cabinet cover raised) set as follows:</p> <p>LF — 1 or 2 (Option 20.a. or b.) Forms — On or Off (Option 39.a. or b.) Test — Off</p> <p>d. Cabinet cover closed.</p> <p>e. In addition to those options in c. the following printer options must be selected: 17.c. (80 column) or 17.e. (132 column), 19.a. or c., 23.b., 57.a., 58.a., 60.b. and 61.c.</p>		If results are not as stated for a particular option, verify installation of that option.
2	Turn on power.	IN SERVICE lamp lights, fan moves air (table top cabinet only) or POWER lamp lights (forms-access cabinet only).	Integrated Synchronous ROP Terminal Analysis. Table D, Page 14.
3	<p>a. Go to location of station data set in building. Contact DATA-SPEED Test Center and request End-to-End Installation Test.</p> <p>b. Establish line connections per DTC instructions, then observe carrier on indicators indicating line established to DTC.</p>	<p><u>201C</u> <u>208A, 208B, 209A</u> MC — Goes Off ER — Goes Off CO — Lights CO — Lights</p> <p><u>212A — L1A</u> MC — Goes Off</p>	Check data sets per applicable troubleshooting section.
4	If talk line to the DTC is not available after test is requested, verify that the test has started by observing the RS/CS lamps on the front of the data set.	<p>RS/CS lamps on the front of the data set should flash ON and then OFF during testing.</p> <p><i>Note:</i> On 212 data sets the SD/RD lamps should flash ON and then OFF during testing.</p>	Inform DTC of problem.
5	<p>The DTC will perform the remainder of the test.</p> <p>On receiving the Selection sequence as specified by Option 171.</p>	<p>DTC will inform of test acceptance or trouble. Call DTC back, if required.</p> <p>The POL/SEL will flash once for one second and then remain lit.</p>	Integrated Synchronous ROP Terminal Analysis. Table D, Page 14.

TABLE B (Cont)

END-TO-END INSTALLATION TEST PROCEDURES

STEP	PROCEDURE	RESULTS	TROUBLE ANALYSIS	
5 (Cont)	The following controller options should be verified while the DTC is conducting the On-Line Test.			
	Space Extension	170a	Only one space per space character received.	Check for proper option. Integrated Synchronous Controller Analysis, Table E, Page 16.
		170b		
	Additional functions receiving one of the following characters:			
	ETB	173a	Block terminator only.	
		173b		
	ETX	174a	Block terminator or terminates an HT setting sequence.	
		174b		
	ITB	175a	Intermediate block terminator only.	
		175b		
	LF(EBCDIC)/NL	176a	Executes printing a line, executes VT ESC sequence (or New Line, if no tabs set) or terminates an HT setting sequence.	
		176b		
	RS/IRS (EBCDIC)	177a	Executes printing a line, and executes a VT ESC sequence (or New Line, if no tab setting).	
		177b		
Permanent Request to Send	167a	RS lamp on data set OFF when receiving.		
	167b		RS lamp ON while sending or receiving.	

TABLE B (Cont)
END-TO-END INSTALLATION TEST PROCEDURES

STEP	PROCEDURE	RESULTS	TROUBLE ANALYSIS
5 (Cont)	<p>Immediate WACK 178a</p> <p><i>Note:</i> If Option 179.b. is enabled the ROP will not respond with a WACK regardless of the choice of Option 178. 178b</p> <p>Check the following features:</p> <p>Bell characters received.</p> <p>Paper-Out — Tear form off below printer cabinet.</p> <p>Carriage Return on ESC M.</p> <p>Space Compression/Expansion ASCII — DTC sends: GSB GSO GSZ</p> <p>EBCDIC — DTC sends: IGS & IGS & IGS \$</p> <p>Determine from DTC where On-Line Horizontal Tabs (ESC HT) are set.</p>	<p>When the buffer is full, the ROP Terminal will respond with WACK to every block of data. The ROP will respond with a WACK to every second block of data.</p> <p>Tone is heard. If Bell characters are less than one second apart, a continuous tone will be heard.</p> <p>PAPER lamp lights when end of form passes paper out switch, an EOT reply is sent if requested within three seconds. Following an EOT reply or if no reply is requested within three seconds of the paper out, the ALARM lamp will light and the audible alarm will sound for eight seconds. The terminal will then disconnect.</p> <p>The M is not printed; the character following the M is printed at the left-hand margin.</p> <p>The terminal receives:</p> <p style="padding-left: 40px;">2 spaces 15 spaces 26 spaces</p> <p>The terminal receives: 10 spaces 16 spaces 27 spaces</p> <p>Horizontal Tabs set per DTC.</p>	<p>See Trouble Analysis for Space Extension.</p> <p>Alarm volume. Opcon Analysis, Table F, Page 18. Integrated Synchronous Controller Analysis, Table E, Page 16.</p> <p>Cabinet Analysis, Section 582-212-400. Opcon Analysis, Table F, Page 18.</p> <p>Integrated Synchronous Controller Analysis, Table E, Page 16.</p> <p>Integrated Synchronous Controller Analysis, Table E, Page 16.</p> <p>Integrated Synchronous Controller Analysis, Table E, Page 16.</p>

TABLE B (Cont)

END-TO-END INSTALLATION TEST PROCEDURES

STEP	PROCEDURE	RESULTS	TROUBLE ANALYSIS
5 (Cont)	<p>Single Line Feed</p> <p><i>Note:</i> Single line feed assumes Printer Option 20.a. Option 20.b. will result in a two-line movement.</p> <p>Double Line Feed</p> <p><i>Note:</i> Double line feed assumes Printer Option 20.a. Option 20.b. will result in a four-line movement.</p> <p>Triple Line Feed</p> <p><i>Note:</i> Triple line feed assumes Printer Option 20.a. Option 20.b. will result in a six-line movement.</p> <p>Form Feed</p> <p>Vertical Tab (VT)</p>	<p>An ESC Q (ASCII) or ESC/ (EBCDIC) when followed by LF (EBCDIC)/NL with Option 176.a., ETB with Option 173.b., ETX with Option 174.b. or IRS (EBCDIC)/RS with Option 177.a. will cause the next character to be printed at the left-hand margin in the next lower line.</p> <p>An ESC R (ASCII) or ESC S (EBCDIC) when followed by LF (EBCDIC)/NL with Option 176.a., ETB with Option 173.b., ETX with Option 174.b. or IRS (EBCDIC)/RS with Option 177.a. will cause the next character to be printed at the left-hand margin in the second line below the present print line.</p> <p>An ESC S (ASCII) or ESC T (EBCDIC) when followed by LF (EBCDIC)/NL with Option 176.a., ETB with Option 173.b., ETX with Option 174.b. or IRS (EBCDIC)/RS with Option 177.a. will cause the next character to be printed at the left-hand margin in the third line below the present print line.</p> <p>With Printer Option 39.b. (Forms OFF) a received FF (Form Feed) character will result in a single line feed with Printer Option 20.a. or a double line feed with Printer Option 20.b.</p> <p>With Printer Options 39.a. (Forms ON) and 20.a. or 20.b., the paper will advance until the next form is in registration.</p> <p>A VT will cause the next character to be printed in the first printing position of the next lower line that corresponds to a preset VT position. If no stops exist between the present print location and the end of the form, then the VT will cause a form feed to be performed.</p>	<p>Check for proper options. Printer Analysis, Section 582-210-500. Integrated Synchronous Controller Analysis, Table E, Page 16.</p> <p>Check for proper option. Printer Analysis, Section 582-210-500. Integrated Synchronous Controller Analysis, Table E, Page 16.</p> <p>Check for proper options. Printer Analysis, Section 582-210-500. Integrated Synchronous Controller Analysis, Table E, Page 16.</p> <p>Check for proper options. Printer Analysis, Section 582-210-500. Integrated Synchronous Controller Analysis, Table E, Page 16.</p>

TABLE B (Cont)

END-TO-END INSTALLATION TEST PROCEDURES

STEP	PROCEDURE	RESULTS	TROUBLE ANALYSIS
5 (Cont)	<p>ESC Vertical Tabs</p> <p>ESC A — Vertical Tab No. 1</p> <p>ESC B — Vertical Tab No. 2</p> <p>ESC C — Vertical Tab No. 3</p> <p>ESC D — Vertical Tab No. 4</p> <p>ESC E — Vertical Tab No. 5</p> <p>ESC F — Vertical Tab No. 6</p> <p>ESC G — Vertical Tab No. 7</p> <p>ESC H — Vertical Tab No. 8</p> <p>ESC I — Vertical Tab No. 9</p> <p>ESC J — Vertical Tab No. 10</p> <p>ESC K — Vertical Tab No. 11</p> <p>ESC L — Vertical Tab No. 12</p> <p>§ The above ESC Vertical Tab positions correspond to the 12 preset tab positions.</p>	<p>An ESC α when followed by LF (EBCDIC)/NL with Option 176a, ETB with Option 173b, ETX with Option 174b, or IRS (EBCDIC)/RS with Option 177a will cause the next character to be printed at the first printing position of the designated vertical tab position. If the received ESC α sequence calls for movement to a position that is above the present location on the form, the printer will be directed to advance to the indicated line on the next form.</p> <p>If the ESC α sequence invokes a position where no preset tab stop exists, then a form feed operation will be performed. If the location corresponding to the received ESC α is the same as the present print position, no paper movement will occur.</p>	<p>Check for proper options. Printer Analysis, Section 582-210-500.</p> <p>Integrated Synchronous Controller Analysis, Table E, Page 16.</p>

CHECKOUT OF RECEIVED PRINTER MESSAGE

TABLE C

CHECKOUT OF RECEIVED PRINTER MESSAGE

STEP	PROCEDURE	RESULTS	TROUBLE ANALYSIS
1	After printing stops, the printer motor should turn off.	With Controller Option 148a approximately 30 seconds. With Controller Option 148b approximately three minutes.	Integrated Synchronous Controller Analysis, Table E, Page 16.
2	Determine from DTC what message was sent. Check for correctness of printed message.		

TABLE C (Cont)

CHECKOUT OF RECEIVED PRINTER MESSAGE

STEP	PROCEDURE	TROUBLE ANALYSIS	RESULTS
3	Check for left-hand margin.	Left-hand margin must match Left-Hand Margin Option as specified by Printer Option 17.a. and Controller Options 121 and 131.	Printer Analysis, Section 582-210-500. Integrated Synchronous Controller Analysis, Table E, Page 16.
4	Check for right-hand margin.	Right-hand margin must match Right-Hand Margin Option as specified by Printer Option 17.c. for 80-column printers or 17.e. for 132-column printers and diode removed to indicate last printing column.	Printer Analysis, Section 582-210-500.
5	<p>Check for paper feed out.</p> <p>With Printer Option 18.a.</p> <p>With Printer Options 18.b. or c. and 39.a.</p> <p>With Printer Options 18.b. or c. and 39.b.</p> <p><i>Note:</i> Option 18.c. not recommended.</p>	<p>No feed out.</p> <p>Feed out to next form feed position.</p> <p>Maximum 16 lines; will be shorter if form feed position occurs before 16-line feed out.</p>	Printer Analysis, Section 582-210-500.
6	<p>Check for Up-Low printing.</p> <p>Up-low printer with Printer Option 21a and Controller Option 162a.</p> <p>Up-low printer with Printer Option 21b and Controller Option 162a.</p> <p>Monocase printer with Printer Option 22a and Controller Option 162a.</p> <p>Monocase printer with Printer Option 22b and Controller Option 162a.</p> <p>Optimized printer with Printer Option 22a and Controller Option 162b.</p> <p>Optimized printer with Printer Option 22b and Controller Option 162b.</p>	<p>Upper and lower case characters should appear in the text.</p> <p>No lower case characters should appear in text.</p> <p>Errored character symbols appear in place of lower case characters.</p> <p>Only upper case characters appear in text.</p> <p>Errored character symbols appear in place of lower case characters.</p> <p>Only upper case characters appear in text.</p>	Printer Analysis, Section 582-210-500.

TABLE C (Cont)

CHECKOUT OF RECEIVED PRINTER MESSAGE

STEP	PROCEDURE	TROUBLE ANALYSIS	RESULTS
7	Check for preset horizontal tab settings (Controller Option 122).	With Controller Option 122.a., no horizontal tabs set. With Controller Option 122.b. tabs set as specified. <i>Note:</i> A diode representing the last printing column must be removed in Option 122.	Integrated Synchronous Controller Analysis, Table E, Page 16.
8	Check for preset vertical tab settings (Controller Option 123).	With Controller Option 123a, no vertical tabs are set. With Controller Option 123c through 123n, tabs set as specified.	Integrated Synchronous Controller Analysis, Table E, Page 16.
9	Check printed copy for test pattern. AMZZMAAMZZMAamzzmaAMZZ... for the Up-low printer or AMZZMAAMZZMAAMZZMAAMZZ... for the Monocase printer.	Repeating pattern should appear without any errors.	Printer Analysis, Section 582-210-500.
THIS ENDS CHECKOUT OF RECEIVED PRINTER MESSAGE.			

3. TROUBLESHOOTING

GENERAL

3.01 When installing a replacement component, make certain that all options (if present) in this component are implemented for proper set operation.

Note: In the absence of instructions to the contrary, return all components not repairable in the field to Western Electric per local instructions.

3.02 Once the trouble has been corrected, the terminal should be checked out to be sure that it is performing properly. Refer to Part 2 for Operational Checkout.

3.03 The following caution procedures must be observed when troubleshooting a 40-Type Station or Set.

Caution 1: Turn off all power before removing or replacing any component of the 40-Type Station or Set.

Caution 2: To avoid possible internal damage to MOS circuitry, use a 346392 static discharge strap as discussed in Section 582-202-200.

3.04 To locate components, circuit cards, connectors, test switches, indicator lamps and other elements indicated in the troubleshooting information, refer to Section 582-202-700.

3.05 The troubleshooting information is divided into:

Terminal Analysis — Table D
Component Analysis — Tables E and F

Component Analysis is broken down into:

- A. Integrated Synchronous Controller — Table E
- B. Operator Console — Table F

3.06 Recommended Procedures: If trouble is known, proceed with the appropriate Component Analysis, ie, printer, etc. If trouble is not known, begin with Terminal Analysis and then proceed with Component Analysis.

TERMINAL ANALYSIS

TABLE D

INTEGRATED SYNCHRONOUS ROP TERMINAL ANALYSIS

ANALYSIS QUESTION	"YES" RESPONSE DIRECTIVE	"NO" RESPONSE DIRECTIVE
<p>1. Is IN SERVICE key lit?</p>	<p>Go to 2.</p>	<p>Make certain that plug on power cord is properly seated in power outlet.</p> <p>Make certain that power switch is on.</p> <p>If power plug is properly connected, all switches are on, and no lamps are lit, determine whether power supply in the building has failed by checking lights in the room, etc.</p> <p>Make certain that all connectors inside cabinet are securely mated and that printer cover is closed.</p> <p>Make certain PAPER alarm light is off.</p> <p>Go to Cabinet Analysis, Section 582-212-400.</p> <p>Go to Integrated Synchronous Controller Analysis, Table E, Page 16.</p>
<p>2. Does test message print correctly when TEST key is depressed (IN SERVICE key off)?</p>	<p>Go to 4.</p>	<p>If about half of test message is replaced by font identification symbols (\bar{A}, etc), verify that Option 19a or c is installed. Otherwise, go to 3.</p>
<p>3. Does type carrier symbol print in every column when printer Test switch is on and cover is closed?</p> 	<p>Go to Integrated Synchronous Controller Analysis, Table E, Page 16.</p> <p><i>Note:</i> After several lines of type carrier symbols the ALARM, IN SERVICE and TEST lamps may flash.</p>	<p>Go to 80-Column or 132-Column Printer Analysis, Section 582-210-500.</p>

TABLE D (Cont)

INTEGRATED SYNCHRONOUS ROP TERMINAL ANALYSIS

ANALYSIS QUESTION	"YES" RESPONSE DIRECTIVE	"NO" RESPONSE DIRECTIVE
<p>3. (Cont) Open cover. Slide Test switch to ON position. Rethread paper through guide window in cover. Close cover.</p> <p>⊖ ⊖ ⊖ ⊖ ⊖ ⊖ or ⊖ ⊖ ⊖ ⊖ ⊖ ⊖ ⊖ ⊖ ⊖ ⊖ ⊖ ⊖ symbols should be printed until cover is reopened (80-column tractor feed printer). Slide Test switch to OFF position.</p> <p>⊖ symbols should be printed until cover is reopened (132-column tractor feed printer). Slide Test switch to OFF position.</p>		
<p>4. Are messages received on-line?</p>	Go to 5.	<p>Check data set and associated cables.</p> <p>Go to Integrated Synchronous Controller Analysis, Table E, Page 16.</p>
<p>5. Do received messages contain errors?</p>	<p>Check data set and associated cables.</p> <p>Go to Integrated Synchronous Controller Analysis, Table E, Page 16.</p> <p>Go to 80-Column or 132-Column Printer Analysis, Section 582-210-500.</p>	

COMPONENT ANALYSIS

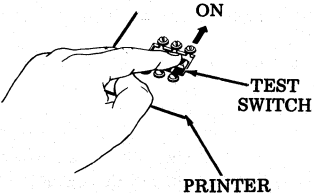
A. Integrated Synchronous Controller

TABLE E

INTEGRATED SYNCHRONOUS CONTROLLER ANALYSIS

ANALYSIS QUESTION	"YES" RESPONSE DIRECTIVE	"NO" RESPONSE DIRECTIVE
<p>1. Were any opcon lamps flashing (not ON steady or flickering rapidly)?</p>	<p>Refer to Opcon Lamp Analysis below. If controller trouble is indicated, go to 2; if not, take step indicated.</p>	<p>If no lamps are ON, verify that P6 (left side) and P21 (rear) connectors are connected firmly; if so, check printer for selection of Option 60.b., character set Option 19 for proper character set selection and check voltages to controller using wiring diagram in Section 582-202-400. If good, go to 2.</p> <p>If all four lamps are ON steady, press key. If lamps do not reset, check both 129919 4 amp SL-BL fuses on rear of printer; if good, replace printer.</p> <p>If lamps reset when depressed, go to 4.</p>

Opcon Lamps Flashing

<u>ALARM</u>	<u>POL SEL</u>	<u>IN SERVICE</u>	<u>TEST</u>	<u>Required Action</u>
X			X	Verify that SSI cable (P5 connector) is securely mated to card. If so, refer to Printer Analysis, Section 582-210-500. ¶
X		X		Refer to Printer Analysis, Section 582-210-500. ¶
X	X	X		Refer to Printer Analysis, Section 582-210-500. ¶
X	X	X	X	Refer to Printer Analysis, Section 582-210-500. ¶ ††
X	X			Refer to Printer Analysis, Section 582-210-500. ¶
X	X	X	X	Replace circuit card 410733; if flashing lamps continue, refer to Integrated Synchronous Controller Analysis, Table E, Page 16.**

¶ If printer analysis indicates printer is good, refer to Integrated Controller Analysis, Table E, Analysis Question 2, Page 16.

**In addition to the indicated lamps flashing the two unmarked lamps will flash.

††These lamps may flash after printing several lines of type carrier symbols with the printer in the TEST mode.

Opcon Lamp Analysis

TABLE E (Cont)

INTEGRATED SYNCHRONOUS CONTROLLER ANALYSIS

ANALYSIS QUESTION	"YES" RESPONSE DIRECTIVE	"NO" RESPONSE DIRECTIVE
2. Have compatible (usable) options been selected?	Go to 3.	Review Section 582-202-200 and eliminate any incompatible or undesirable option selections. Change options and retest.
3. Have all controller options (121 through 190) been verified?	Go to 4.	<p>Check for wrong switch settings for Options 189 and 190.</p> <p>Check for removed or open diodes of Options 121 – 123, 125, 131, 148 and 159 – 188 by removing the rightmost blocking keytop and depressing the keyswitch (with the IN SERVICE lamp extinguished). The printer will print out a matrix of –s for diodes "IN" and x's for diodes "OUT" or "OPEN". Compare printout with option list. Replace blocking keytop.</p> <p>Replace 410734 card or replace any open or incorrectly cut diodes on card with 407336 diodes and cut out any diodes that should not be in. If all options are good, go to 4.</p>
4. Replace 410733 and 410735 cards as a unit and retest. Is trouble cleared?	Go to 5.	Replace 410734 card.
5. Replace 410733 card alone (use original 410735 card) and retest. Is trouble cleared?	Original 410733 card is defective.	<p>Original 410735 card is probably defective. Replace it alone and retest. Further trouble may indicate cables or connectors are defective.</p> <p>Go to Opcon Analysis, Table F, Page 18.</p>

B. Operator Console (Opcon)

TABLE F
OPCON ANALYSIS

ANALYSIS QUESTION	"YES" RESPONSE DIRECTIVE	"NO" RESPONSE DIRECTIVE
1. Do any lamps light?	Go to 2.	Check for open in ground lead.
2. Does IN SERVICE lamp light when power is turned on? (Cabinet lid closed and no paper alarm.) Depress IN SERVICE key if motor is running.	Go to 5.	Go to 3.
3. Is approximately +12 V dc present at pins 1, 3, 5, 7 or 16 with respect to frame ground (pin 13) when ALARM, TEST, IN SERVICE or POL/SEL lamps should be lit?	Check wiring to failing key-switch indicator or audible alarm. Replace keyswitch or 410765 circuit card.	Go to 4.

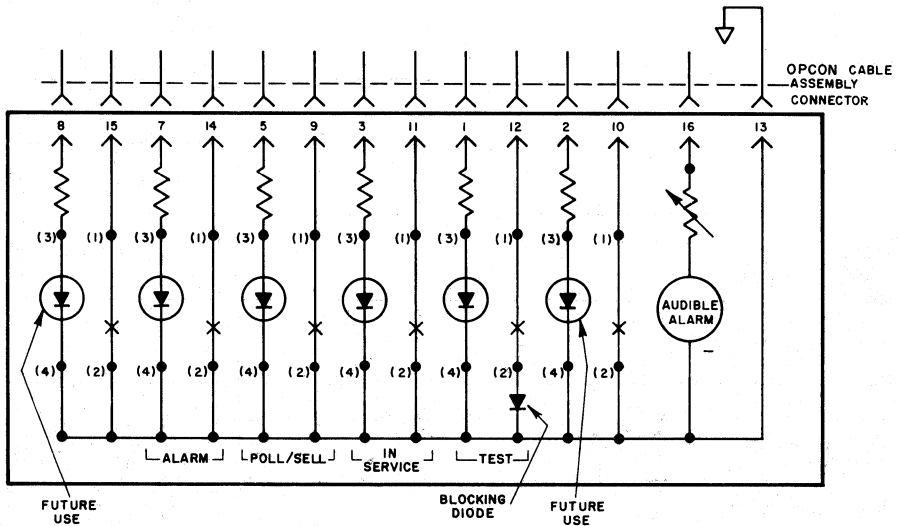

4. Is +12 V dc present when associated keyswitch is removed? (See ROP Opcon Schematic.)	Replace shorted keyswitch.	Check for short in wiring across keyswitch.
---	----------------------------	---

TABLE F (Cont)
OPCON ANALYSIS

ANALYSIS QUESTION	"YES" RESPONSE DIRECTIVE	"NO" RESPONSE DIRECTIVE
5. Does test message print when TEST key is depressed with IN SERVICE lamp OFF.	Go to 6.	Check wiring to keyswitch terminals. Replace open keyswitch. Go to Integrated Synchronous Controller Analysis, Table E, Page 16.
6. Does TEST lamp light?	Go to 7.	Go to 3.
7. Does the POL/SEL lamp turn on when the terminal is selected?	Go to 8.	Check wiring to keyswitch. Replace opcon keyswitch. Go to Integrated Synchronous Controller Analysis, Table E, Page 16.
8. When receiving data, does an out of paper condition cause the ALARM lamp to light?	Go to 9.	Check wiring to keyswitch. Replace open keyswitch. Go to Integrated Synchronous Controller Analysis, Table E, Page 16.
9. Does the audible alarm sound?	Go to 10.	Go to 3.
10. Does depressing ALARM key extinguish audible alarm?	Place printer in service.	Check wiring to keyswitch terminals. Replace open diode on keyswitch. Go to Integrated Synchronous Controller Analysis, Table E, Page 16.

INTEGRATED SYNCHRONOUS "DATASPEED*" 40 RECEIVE-ONLY PRINTER STATION
DISASSEMBLY/REASSEMBLY AND PARTS

	CONTENTS	PAGE
1.	GENERAL	1
2.	DISASSEMBLY/REASSEMBLY ...	1
	OPERATOR CONSOLE (Opcon) ...	1
	PRINTER	2
	CONTROLLER	2
	CABINET	7
3.	PARTS	8
	GENERAL	8
	INDEX OF REPLACEMENT PARTS	8
	A. Opcon	8
	B. Printer	8
	C. Controller	8
	D. Cabinet	9

Note: When ordering replaceable components, unless otherwise specified, prefix each part number with the letters "TP" (e.g. TP410055).

2. DISASSEMBLY/REASSEMBLY
OPERATOR CONSOLE (Opcon)

2.01 Reference in the procedures to left or right and up or down and top or bottom, etc, refer to the opcon in its normal operating position.

2.02 For removal of subassembly or parts from the opcon refer to Section 582-211-700.

2.03 To remove 40K003/AAB opcon from cabinet:

- (a) Place thumb on left inward tab of opcon and press downward to unlatched position.
- (b) Hold opcon firmly with left hand; with right hand place thumb on right inward tab and press downward to unlatch position.
- (c) Pull opcon forward.
- (d) Slide opcon ground strap terminal off of cabinet terminal tab.
- (e) Remove connector of cable 406192 from opcon circuit card.

1. GENERAL

1.01 This section provides instructions for disassembly and reassembly of Integrated Synchronous DATASPEED 40 Receive-Only Printer (ROP) Stations. A list of field-replaceable parts for the controller and its cables, indexed to the instructions for their access, is included.

1.02 This section is reissued to include information pertaining to forms access printer arrangements. Since this reissue is a general revision, no revision arrows have been used to denote significant changes.

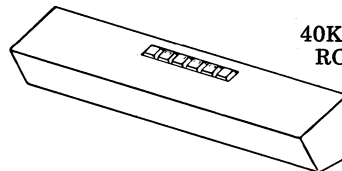

40K003/AAB
RO Opcon

*Registered Trademark of AT&TCo.

SECTION 582-202-700

- 2.04 To replace the 40K003/AAB opcon reverse the steps of 2.03.

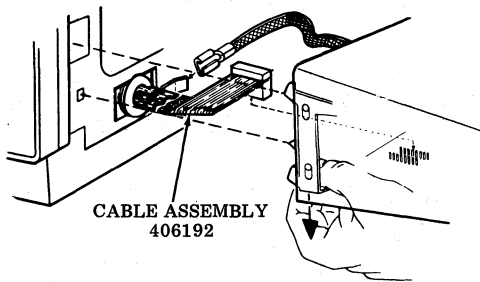

- 2.05 To remove 40K005/AAC opcon from forms access cabinet:

- Open right and left doors of cabinet.
- Hold opcon firmly with left hand.
- Remove two screws.
- Remove opcon from inside of cabinet.
- Remove connector of 406378 cable from opcon circuit card.

- 2.06 To replace the 40K005/AAC opcon reverse the steps of 2.05.

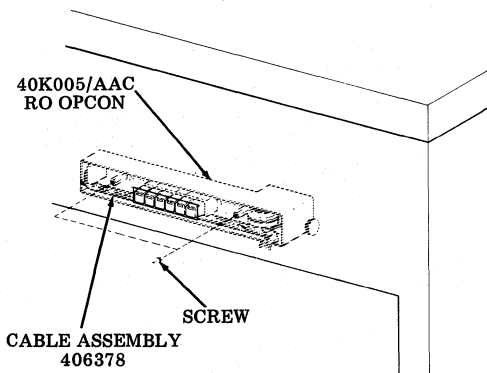

PRINTER

- 2.07 To remove printer from cabinet and replace refer to Section 582-210-750.

- 2.08 Location of fuses:

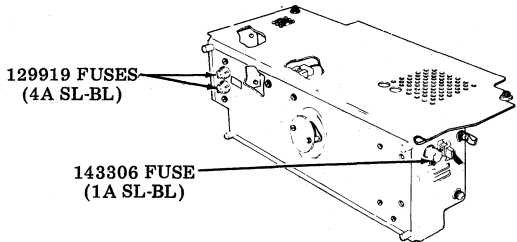

CONTROLLER

Caution: BEFORE handling the integrated controller, observe and follow the static discharge grounding precautions detailed in Section 582-202-200.

- 2.09 Precautions should be taken to assure that the controller is disassembled and reassembled under clean conditions. No oil, grease, or other liquids should be present on loose parts, circuit cards, or cable connectors.

- 2.10 To remove controller from cabinet and replace refer to Section 582-202-200.

2.11 Controller Cabling and Connections

40C303AC/003 Controller for Tractor Feed Table Top Applications

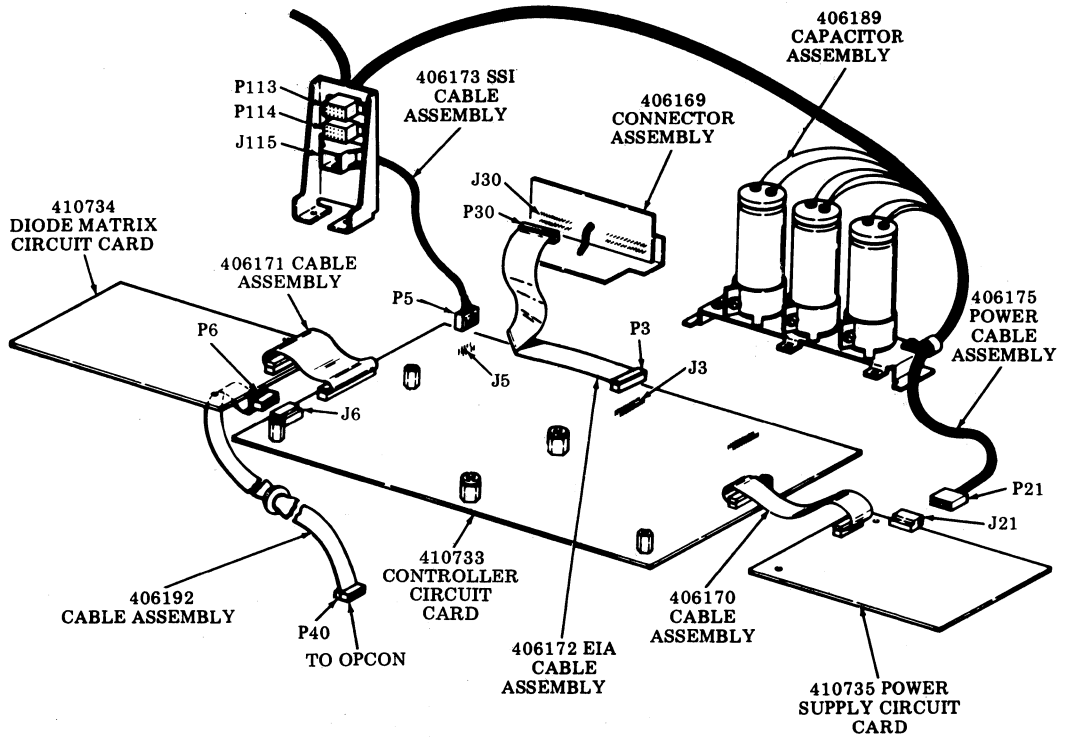

40C303AC/003 Controller for Forms Access Applications

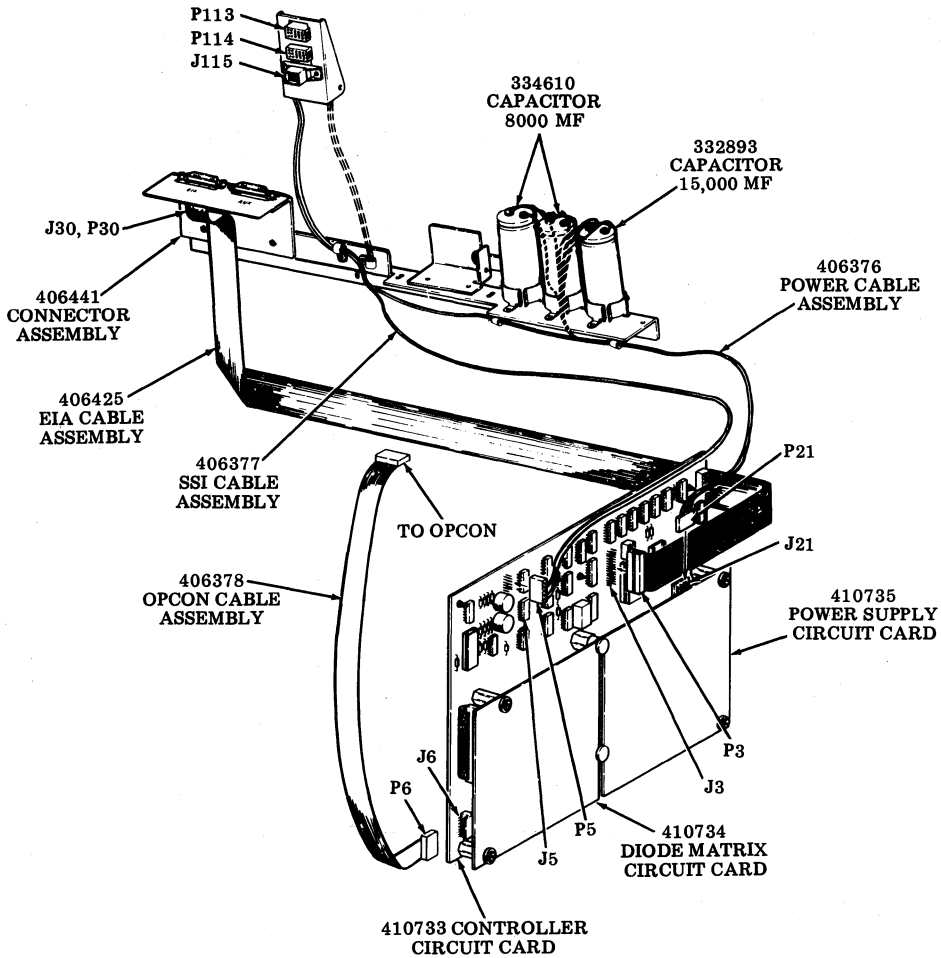

2.12 To remove diode 407336 from card:

- Remove controller (refer to Section 582-202-200).
- Remove controller cover (refer to Section 582-202-200).
- Remove diode matrix card and invert (refer to Section 582-202-200).

① For option purposes, diode should be cut at each end with 408071 cutting pliers and removed completely.

② To reinstall a cut diode, unsolder the cut ends of the previous diode and remove. Insert new diode (see Note) with banded end facing circuit packs as shown above, bend leads, clip off excess, and resolder.

Caution: Soldering iron not to exceed 60 watts.

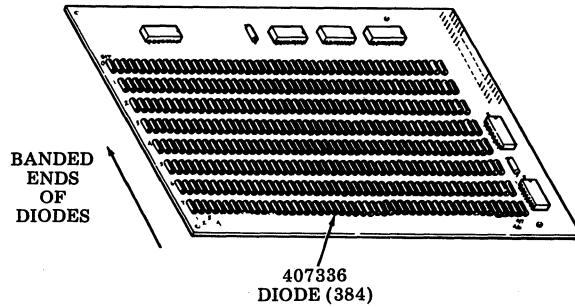

410734 Diode Matrix Card (Inverted)

2.13 Parts Location

40C303AC/003 Controller

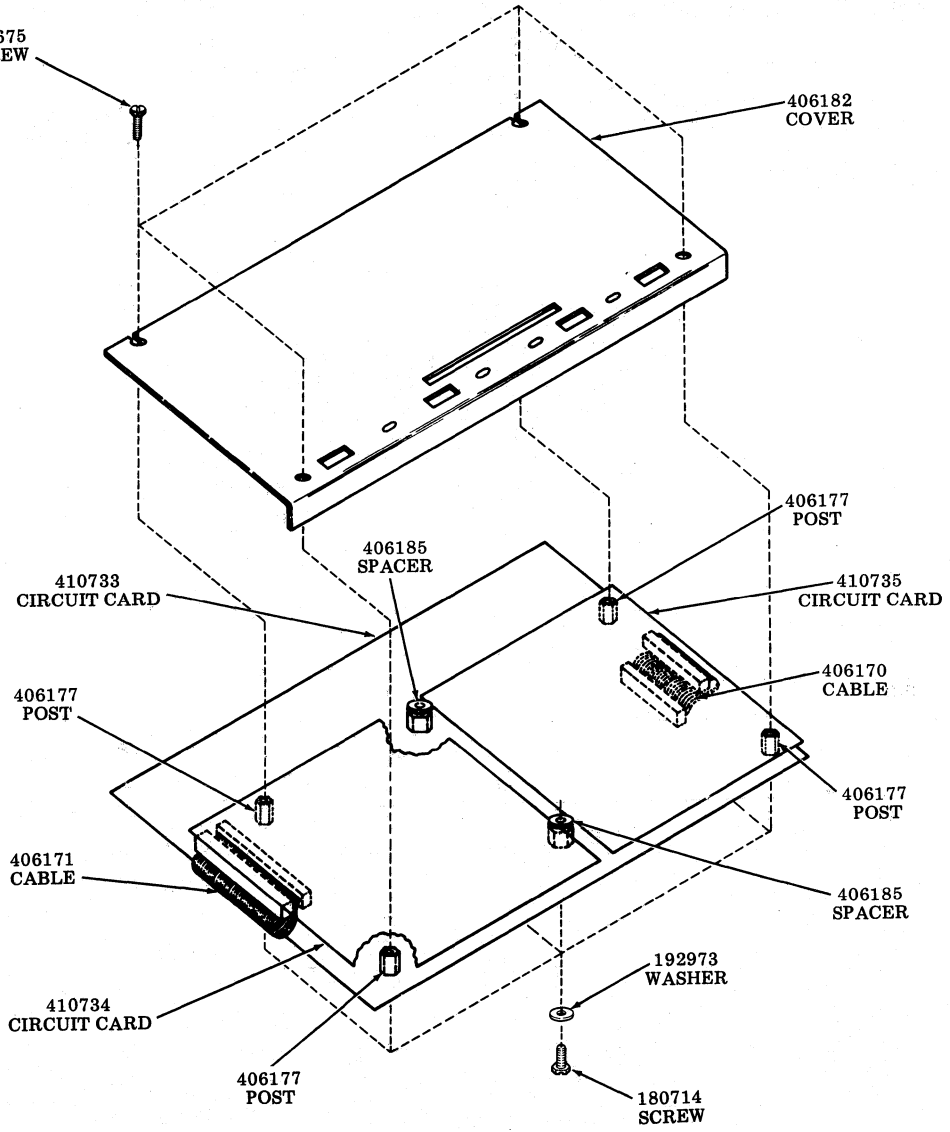

CABINET

2.14 For removal of subassemblies or parts from the cabinet refer to Section 582-212-700.

2.15 To remove data set cables:

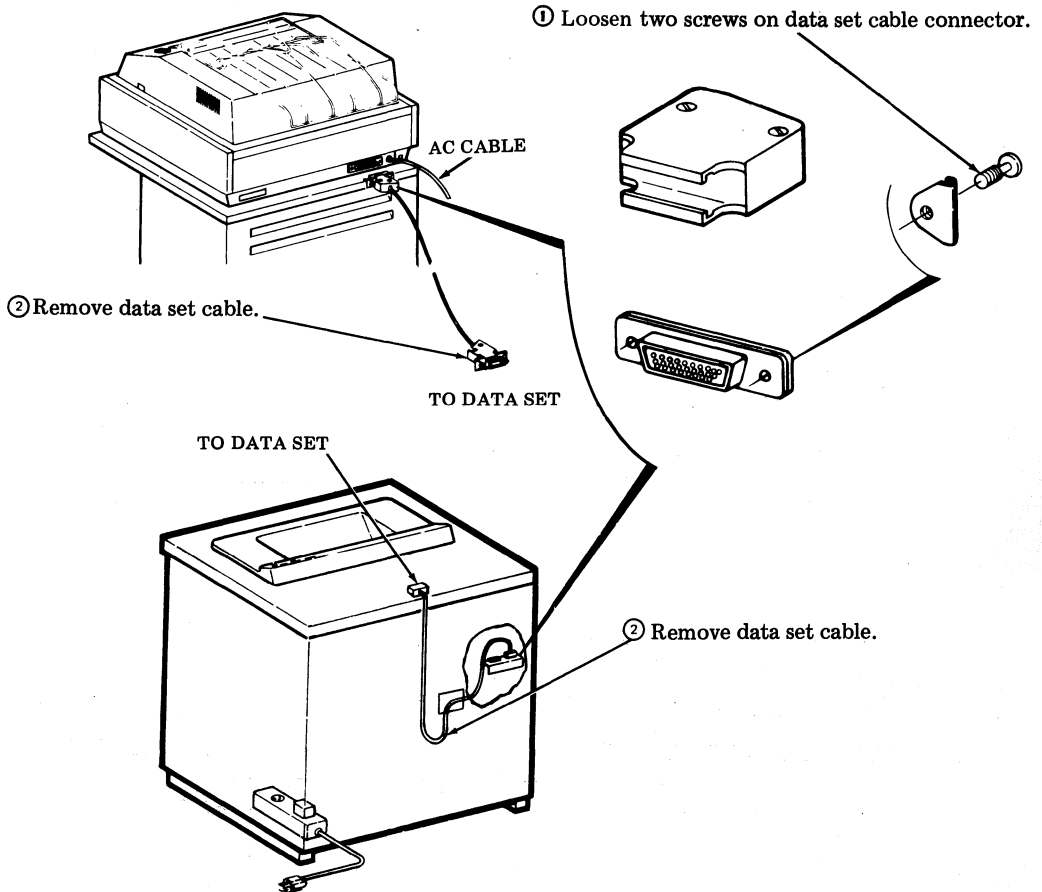

3. PARTS

GENERAL

3.01 All field-replaceable components of the controller and its cables are listed in the following index, showing the page number of this

section on which their access is provided. An illustration of each component will be found on the indicated page.

3.02 Orders for components should prefix each part number with the letters "TP" (e.g. TP410055).

INDEX OF REPLACEMENT PARTS

A. Opcon

OPCON		
PART NO.	DESCRIPTION	PAGE NO.
40K003/AAB	Opcon	1, 2
40K005/AAC	Opcon	2

B. Printer

PART NO.	DESCRIPTION	PAGE NO.
129919	Fuse, 4A SL-BL	2
143306	Fuse, 1A SL-BL MDL-1	2

C. Controller

40C303AC/003 CONTROLLER		
PART NO.	DESCRIPTION	PAGE NO.
180675	Screw, # 6 Self-Tapping	6
180714	Screw, # 6 Self-Tapping	6
192973	Washer, Insulating	6
406170	Cable Assembly	3, 6
406171	Cable Assembly	3, 6
406177	Post	6
406182	Cover	6
406185	Spacer	6
407336	Diode	5
410733	Circuit Card	3, 4, 6
410734	Circuit Card	3, 4, 5, 6
410735	Circuit Card	3, 4, 6

D. Cabinets

40CAB302/ZZ FORMS ACCESS CABINET		
PART NO.	DESCRIPTION	PAGE NO.
332893†	Capacitor	4
334610†	Capacitor	4
406376†	Cable Assembly, Power	4
406377†	Cable Assembly, SSI	4
406378‡	Cable Assembly, Opcon	2, 4
406425†	Cable Assembly, EIA	4
406441†	Connector Assembly, EIA	4

†Part of 406372 modification kit (406372 modification kit converts a 40CAB302/ZZ cabinet into a 40CAB302/AA — refer to Specification 50953S). The 406372 modification kit is used with 40C303AC/003 controller.

‡Part of 40K005/AAC opcon.

40CAB351 OR 40CAB353/YZ TRACTOR FEED CABINET		
PART NO.	DESCRIPTION	PAGE NO.
406169 §	Connector Assembly, Dual	3
406172 §	Cable Assembly, EIA	3
406173 §	Cable Assembly, SSI	3
406175 §	Cable Assembly, Power	3
406189 §	Bracket Assembly, Capacitor	3
406192 §	Cable Assembly, Opcon	3

§ Part of 406190 modification kit (406190 modification kit converts a 40CAB351/YZ cabinet into a 40CAB351/AE and a 40CAB353/YZ cabinet into a 40CAB353/AD — refer to Specification 50915S). Cabinets coded 40CAB351/ZZ and 40CAB353/ZZ may also be used with the 406190 modification kit, however, the cabinet must have a 1-inch by 5-inch cutout in the lower left rear corner to accommodate the dual EIA connector assembly (406169).

INTEGRATED SYNCHRONOUS "DATASPEED 40*" RECEIVE-ONLY PRINTER STATION
ROUTINE MAINTENANCE

1. GENERAL

1.01 This section provides the routine maintenance procedure for Integrated Synchronous DATASPEED 40 Receive-Only Printer (ROP) Stations.

1.02 This section is reissued to include information pertaining to Forms Access printer arrangements.

Note: When ordering replaceable components, unless otherwise specified, prefix each part number with the letters "TP" (ie, TP407062).

2. ROUTINE MAINTENANCE

2.01 The only component of the Integrated Synchronous ROP Station requiring periodic maintenance is the printer. The opcon, the integrated controller, and the cabinet do not require periodic maintenance. Routine maintenance on the printer is covered in Section 582-210-750; when maintenance on the printer is performed, the procedures covered in this section should also be performed on the rest of the ROP Station.

2.02 Check the overall exterior of the station; check that data set cable and power cord are securely connected; check the condition of the cabinet window — replace if damaged or broken.

2.03 Table top arrangement only — turn switch on and check cabinet fan operation. Air should exit from the exhaust vent on the right side of the cabinet (Fig. 1). Check that intake and exhaust vents are not blocked.

Note: Forms Access cabinets do not have fans.

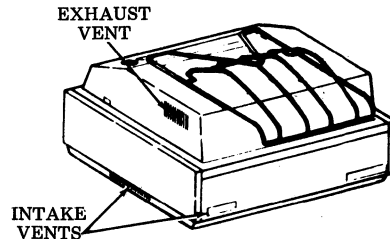

Fig. 1—Air Vents

2.04 Refer to Section 582-210-750 for routine maintenance procedure for printer. With the cabinet power OFF remove printer and perform routine maintenance called for at this time (refer to Section 582-210-200 for printer removal).

2.05 Before reinstalling the printer, examine all cable connections inside the cabinet and make sure they are secure.

2.06 Reinstall printer (refer to Section 582-210-200) in cabinet and close cover. Refer to Section 582-202-500 and perform the off-line checkout given therein.

*Registered Trademark of AT&TCo.

“DATASPEED*” 40 STATION AND COMPONENT REMOVAL

CONTENTS	PAGE	CONTENTS	PAGE
1. GENERAL	2	40BSE201 OPERATOR CONSOLE BASE	39
2. TOOLS REQUIRED	2	40BSE202 OPERATOR CONSOLE BASE	40
3. STATION AND COMPONENT REMOVAL	2	40/9140 STATION CONTROLLER	41
DISPLAY MONITOR	5	EIA SWITCH	43
LOGIC, PRINTER, AND PRINTER CABINET	7	KEYBOARD DISPLAY AMPLIFIER (KDA)	44
FRICTION FEED PRINTER (80-COLUMN)	9	40K00X AND 40K100 OPERATOR CONSOLE	45
TRACTOR FEED PRINTER (80-COLUMN)	11	40K200 OPERATOR CONSOLE ...	47
TRACTOR FEED PRINTER (132-COLUMN)	13	40PSU101 POWER SUPPLY	48
TRACTOR FEED PRINTER (72-COLUMN)	16	40PSU102 POWER SUPPLY	49
TRACTOR FEED PRINTER (80-COLUMN, FORMS ACCESS)	18	40DL291 DISPLAY LOGIC	50
40CAB201 AND 40CAB251 CABINETS	20	40C101, 40C102, 40C201, 40C202, AND 40C204 CONTROLLERS ...	51
40CAB351 AND 40CAB371 CABINETS	21	40C103 CONTROLLER	53
40CAB353 CABINET	23	40C400, 40C401, 40C402, AND 40C403 CONTROLLERS	55
40CAB901 CABINET	25	40C430, 40C431, AND 40C432 CONTROLLERS	57
40CAB902 CABINET	32	40C303 CONTROLLER	58
40CAB904 CABINET	33	40C304 AND 40C305 CONTROLLERS	59
40CAB302 CABINET	35	40C434, 40C435, AND 40C436 CONTROLLERS	62
40AB101 ANSWER-BACK	37	401200 COPY HOLDER	63
40BSE101 CIRCULAR BASE	38	40PWU101 AND 40PWU102 PAPER WINDERS	64
		4. WORKING STATION	65

*Registered Trademark of AT&TCo.

†Issue 1 Did Not Receive Standard Distribution

1. GENERAL

1.01 This section provides station and component removal (station disconnect) information for DATASPEED 40/0, 40/1, 40/2, 40/3, and 40/4. Packing instructions and illustrations are provided to insure proper handling and packing for service disconnects.

1.02 Whenever this section is reissued, the reason for reissue will be listed in this paragraph.

1.03 Station and component removal should be performed under the direction of a service disconnect order indicating the packing materials required, date, and location.

1.04 Do not pack "used" printer ribbon when printers are removed from service (remove and discard). For reference the appropriate packing procedure is shown in this section for packing new ribbon when printer is packed for shipment to service.

1.05 ALL STATIONS AND COMPONENTS REMOVED SHOULD BE RETURNED TO WESTERN ELECTRIC SERVICE CENTER WITHOUT INCURRING DAMAGE. THE PACKING METHODS SPECIFIED HEREIN REPRESENT ONE WAY TO HELP ASSURE SAFE TRANSPORT. A RETURNED MATERIAL TAG

SHOULD BE AFFIXED TO EACH ITEM. (SEE 4. WORKING STATION)

1.06 Pressure sensitive tape, tissue paper, glue, or sealing tape may be obtained locally.

1.07 Factory-type packing may be duplicated by ordering the required PK materials from Teletype Corporation. All other packing materials may be obtained from your local Western Electric Service Center.

2. TOOLS REQUIRED

2.01 The tools required for service disconnects of DATASPEED 40 apparatus are standard and should be present in standard maintenance tools kits.

3. STATION AND COMPONENT REMOVAL

3.01 Reverse the procedures in Part 2 of 579-505-352 for 40/0, Part 7 of 582-200-200 for 40/0 and 40/1, Part 3 of 582-200-202 for 40/2, Part 3 of 582-200-203 for 40/3, and Part 3 of 582-200-201 for 40/4, to remove the station from service (service disconnect).

3.02 When equipment is removed from service, use suitable quantities of packing containers for reshipment of station arrangements or components.

3.03 The following illustrations show some of the recommended packing procedures for reshipment.

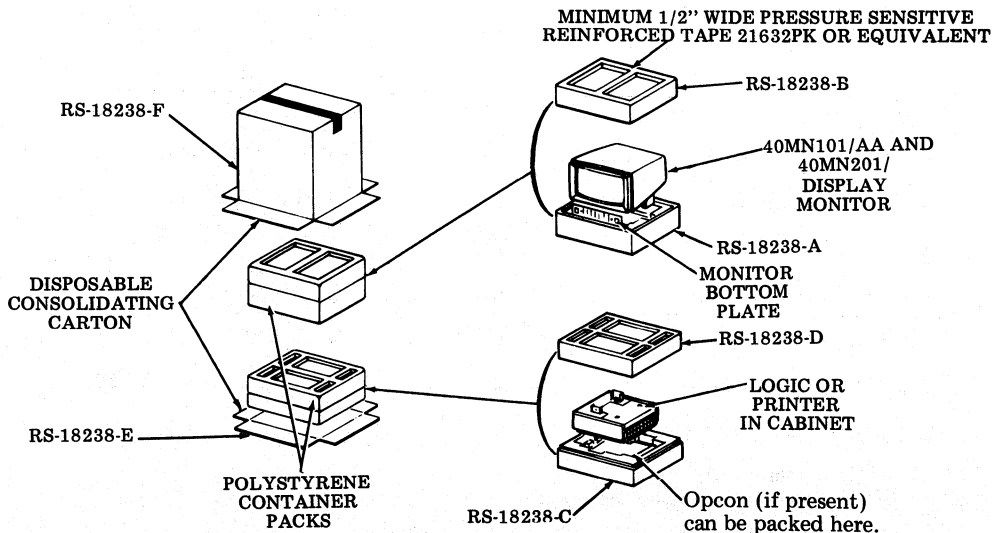

Fig. 1

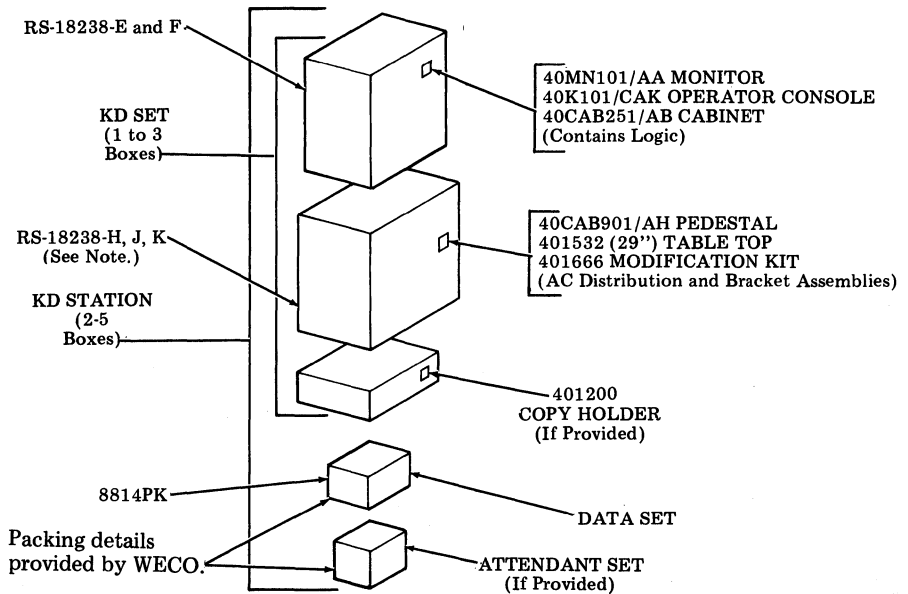

Fig. 2—Typical Packing Details for DATASPEED 40 Station Arrangements

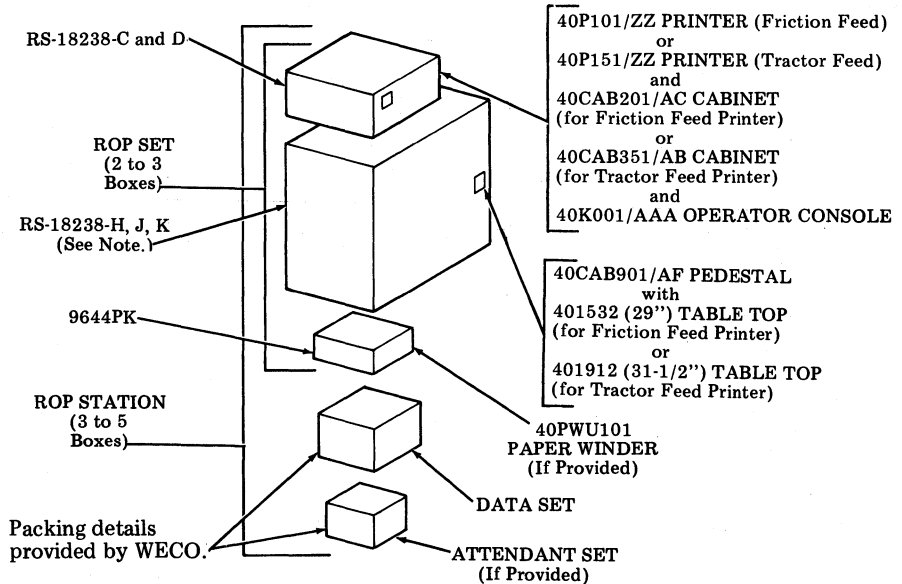
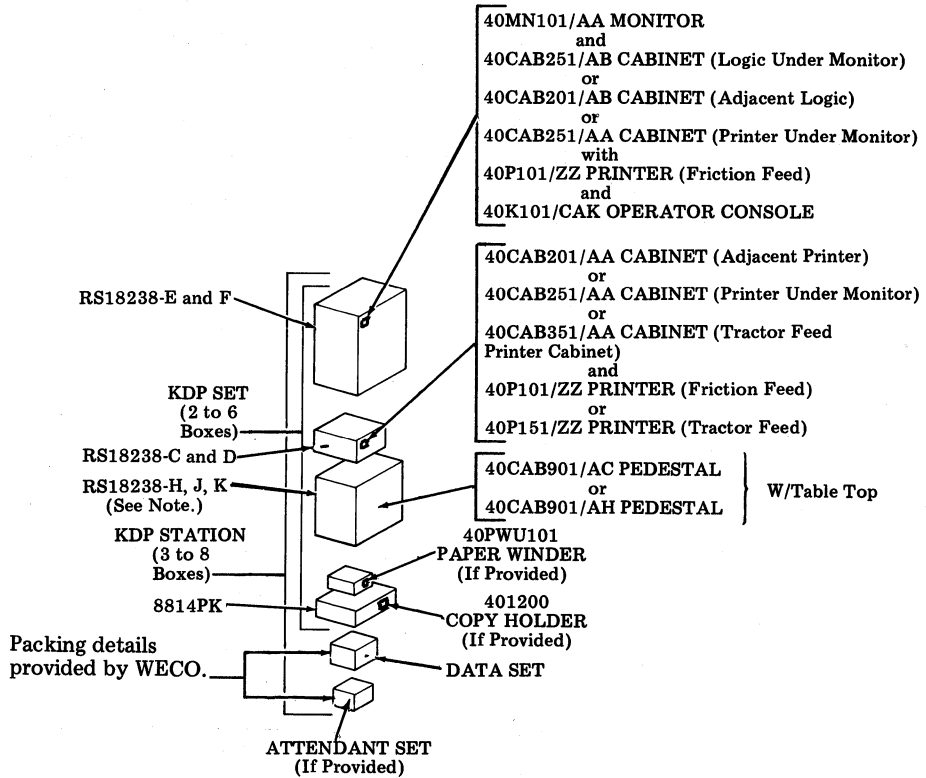

Fig. 3—Typical Packing Details for DATASPEED 40 Station Arrangements (Cont)

Note: Use two RS-18238-K blocking details when packing the pedestal (see Fig. 27).



Note: In a KDP w/tractor feed printer on pedestal, two 40CAB901/AH pedestals must be packed.

Fig. 4—Typical Packing Details for DATASPEED 40 Station Arrangements (Cont)

DISPLAY MONITOR

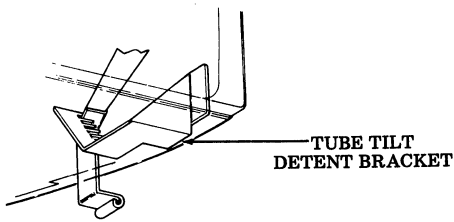

(Late Design)

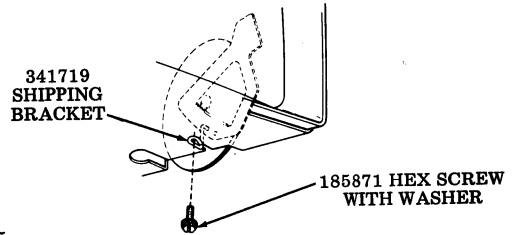

Fig. 5

(Early Design)

Step 1. Remove the 401108 bottom plate from monitor.

Step 1. Remove the 401108 bottom plate from monitor.

Step 2. Move the tilt lever to the front of monitor and engage the lever in the first or second detent position.

Step 2. Immobilize tube tilt mechanism with 341719 shipping bracket as illustrated in Fig. 5.

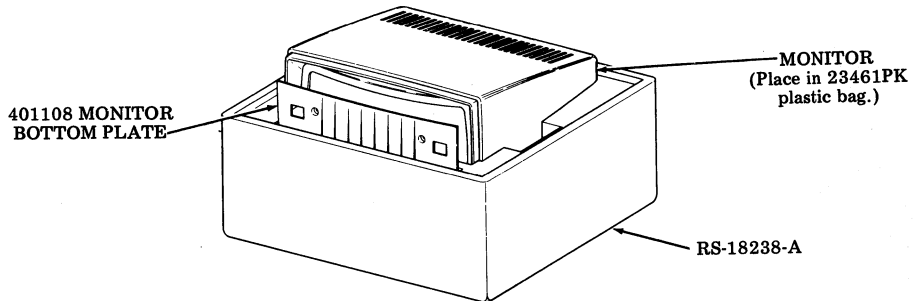

Fig. 6

Step 3. Position monitor and bottom plate in position shown in Fig. 6. Position cover and secure with a band of pressure sensitive reinforced tape, as illustrated in Fig. 7.

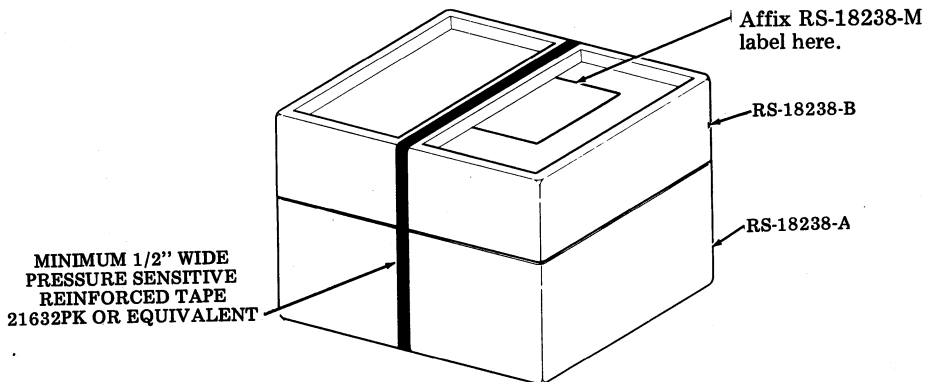

Fig. 7

MONITOR (Alternate Packing Procedure)

- Step 1. Preassemble all parts to bottom of main frame. Mount assembly to a 28381PK pallet with two 28051PK spacers, four 71699RM screws, four 72316RM lock-washers and four 72296RM flat washers. Tighten screws securely. (See Fig. 8.)
- Step 2. Complete assembly of monitor less cover. Invert monitor.
- Step 3. Mount and latch cover. Secure monitor support covers in place with 21632PK tape.
- Step 4. Form 10603PK carton. Close and seal bottom flaps with a strip of 21719PK tape applied along the center seam. The tape should extend approximately three inches down the ends of the carton.
- Step 5. Place unit in carton. Place a 23457PK plastic bag around unit.
- Step 6. Form a 28365PK detail and place in carton at front of unit as illustrated in Fig. 8.

- Step 7. Wrap the bottom plate assembly in a sheet of 21298PK tissue paper. Form a 28364PK detail and secure the wrapped bottom plate to the detail with two bands of 21632PK tape.
- Step 8. Position the detail and bottom plate in the carton.
- Step 9. Close and seal the top flaps of the carton as outlined in Step 4.
- Step 10. Form a 11322PK carton and with bottom flaps down and outward, place around the inner carton.
- Step 11. Position a 27442PK plastic corner on each of the four corners of the inner carton.
- Step 12. Close and seal the top flaps of the carton with 21719PK tape as outlines in Step 4.
- Step 13. Carefully invert carton and contents. Position a 27442PK plastic corner on each of the four corners of the inner carton.
- Step 14. Close and seal bottom flaps of carton as outlined in Step 4. Invert carton.

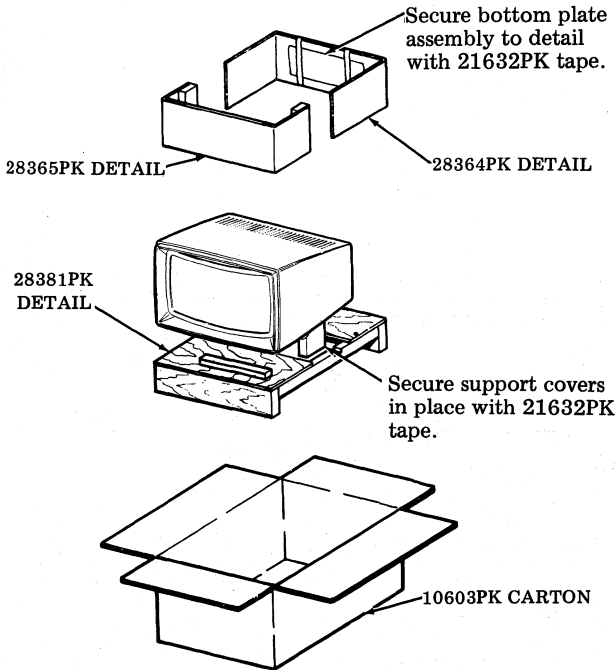

Fig. 8

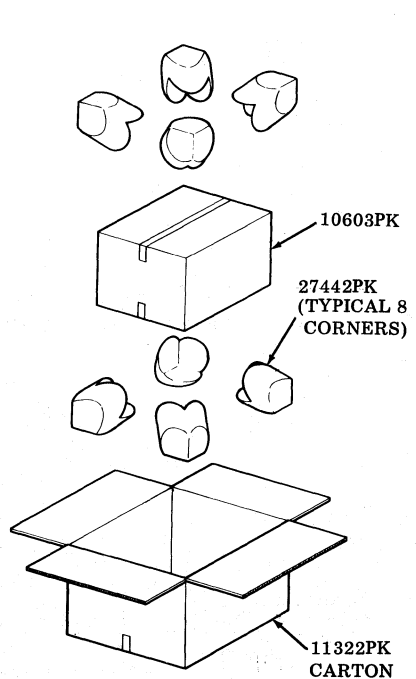

Fig. 9

Note: 23457PK Plastic Bag deleted for clarity.

LOGIC, PRINTER, AND PRINTER CABINET

Step 1. Position logic or printer cabinet in position shown in Fig. 10.

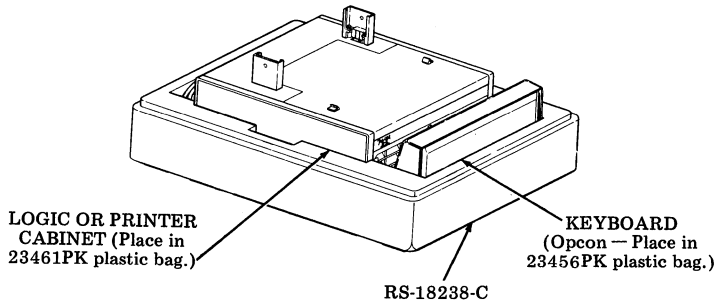

Fig. 10

Step 2. Insert keyboard and any loose cables in space provided in the RS-18238-C detail. See Fig. 11.

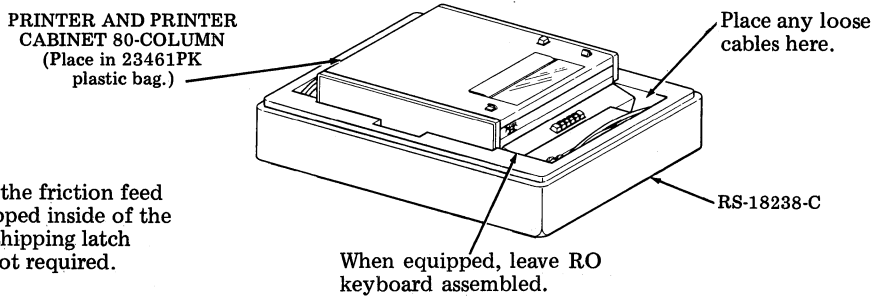

Fig. 11

Step 3. Position cover and secure with two bands of pressure sensitive reinforced tape. See Fig. 12.

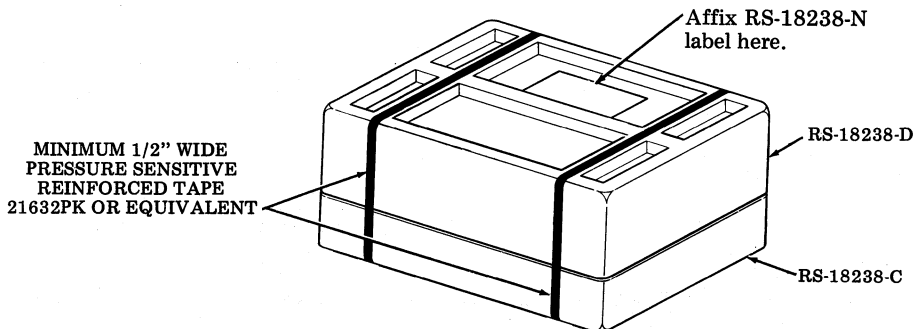

Fig. 12

Note: When available, use consolidating container body RS-18238-F, container base RS-18238-E, along with 1/2 inch wide steel strapping around the base of container. Nylon tape may be used to secure the container base during removal operation.

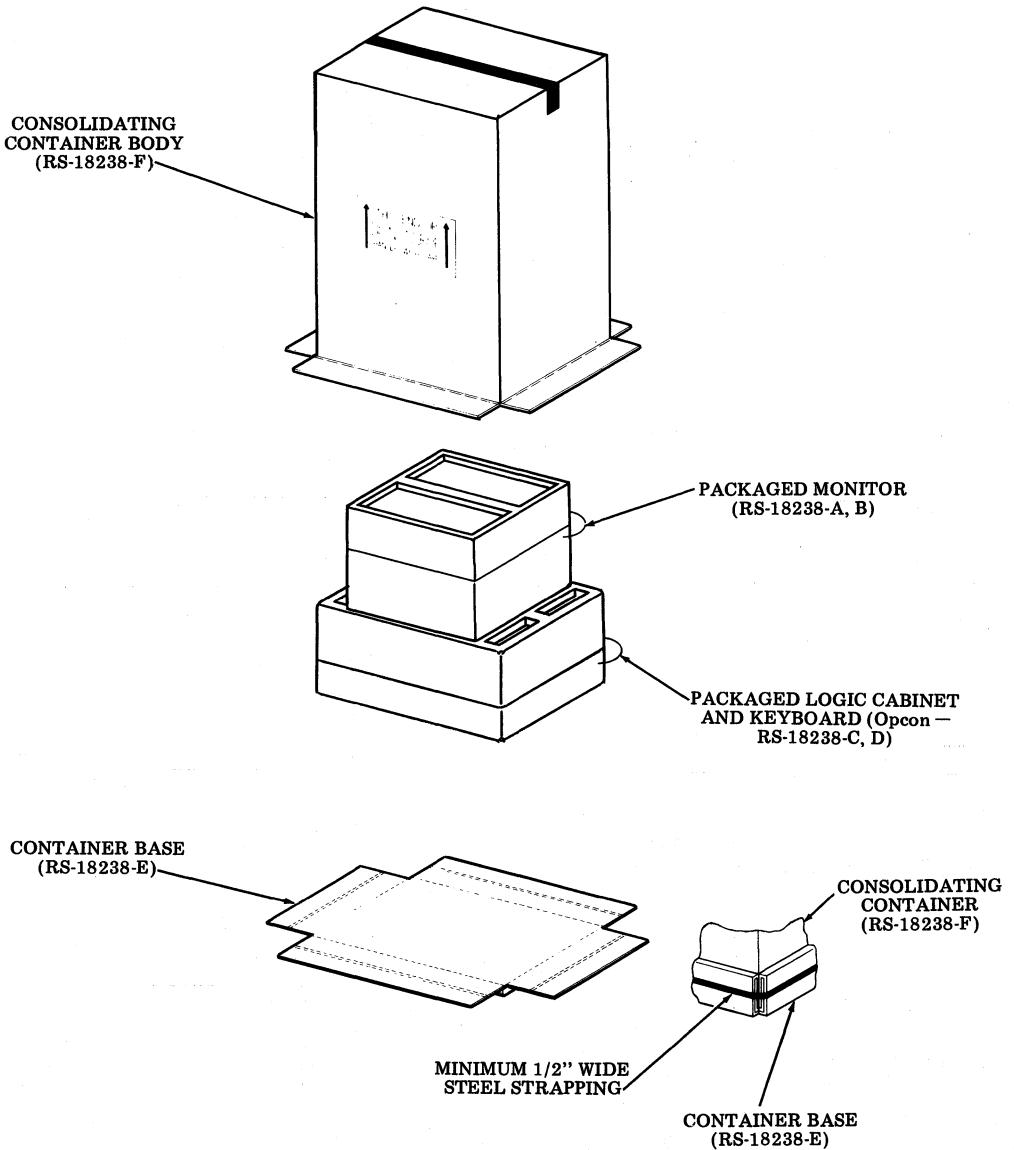
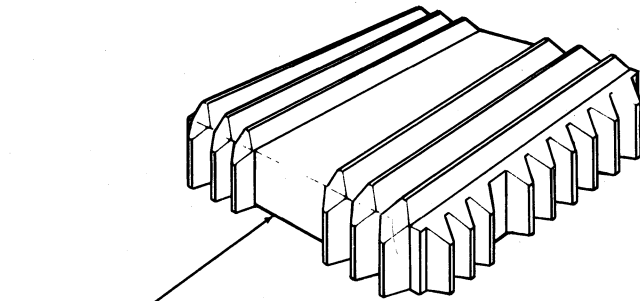

Fig. 13—Packing Logic, Printer, and Printer Cabinet

FRICION FEED PRINTER (80-COLUMN)**Packing Procedure for 40P101 and 40P102 Printers**

- Step 1. Remove printer from printer cabinet.
- Step 2. Remove ribbon spools from printer and discard.
- Step 3. Place paper spindle in position on unit with ribbon spools positioned down.
- Step 4. Form shipping container 10160PK. Close and seal bottom flaps with glue or sealing tape.
- Step 5. Place a plastic detail 28249PK Detail A in the container as illustrated in Fig. 14.
- Step 6. Position unit in plastic base (see Fig. 14).
- Step 7. Position a plastic cover 28249PK Detail B over top of unit (see Fig. 14).
- Step 8. Close and seal top flaps of container as outlined in Step 4.



28249PK
DETAIL B

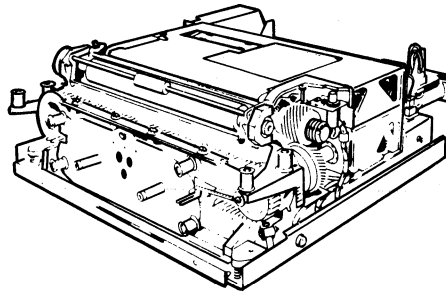

28249PK
DETAIL A

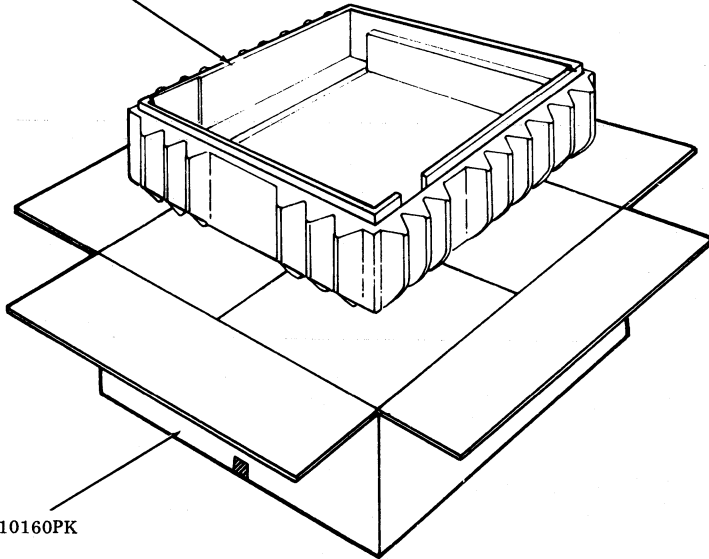

10160PK

Fig. 14

TRACTOR FEED PRINTER (80-COLUMN)

Packing Procedure for 40P150, 40P151, 40P152, 40P153, and 40P154 Printers

- Step 1. Remove printer from printer cabinet.
- Step 2. Position printer on its back. Immobilize unit vibration mounts by tightening the four immobilizing screws. See Fig. 15.

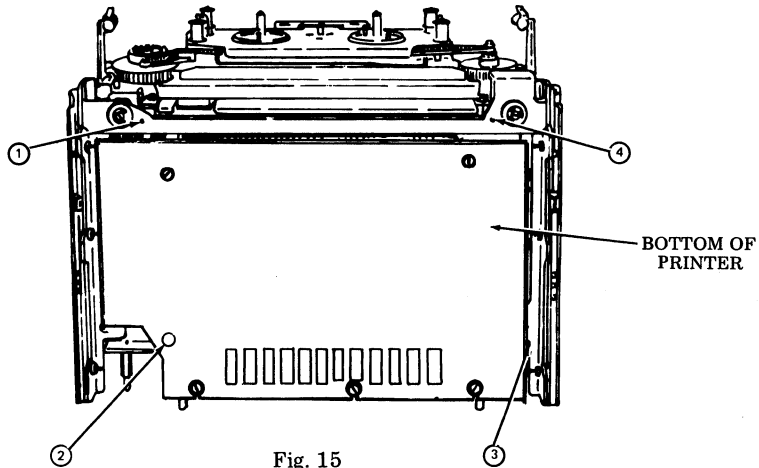

Fig. 15

- Step 3. Set unit upright, secure each of the two ribbon tensioning arms in latched position with 50136PK twist ties as illustrated in Fig. 16.

Caution: Do not tightly apply twist ties. Damage to tensioning arms may result.

- Step 4. Place a plastic base (28279PK Detail A) on work bench as illustrated in Fig. 16. Place printer in base.
- Step 5. Position a 28279PK Detail C along the side of mounting rail at left side of printer and a 28279PK Detail D along the side of the mounting rail at right side of printer. See Fig. 16.
- Step 6. Position a plastic cover (28279PK Detail B) over printer as illustrated in Fig. 16.
- Step 7. Secure details A and B together by applying a band of 21632PK tape around the details as shown in Fig. 16.
- Step 8. Form a 10523PK shipping container. Close and seal bottom flaps with glue or sealing tape.
- Step 9. Place prepacked printer in container. Close and seal top flaps of container as outlined in Step 8.

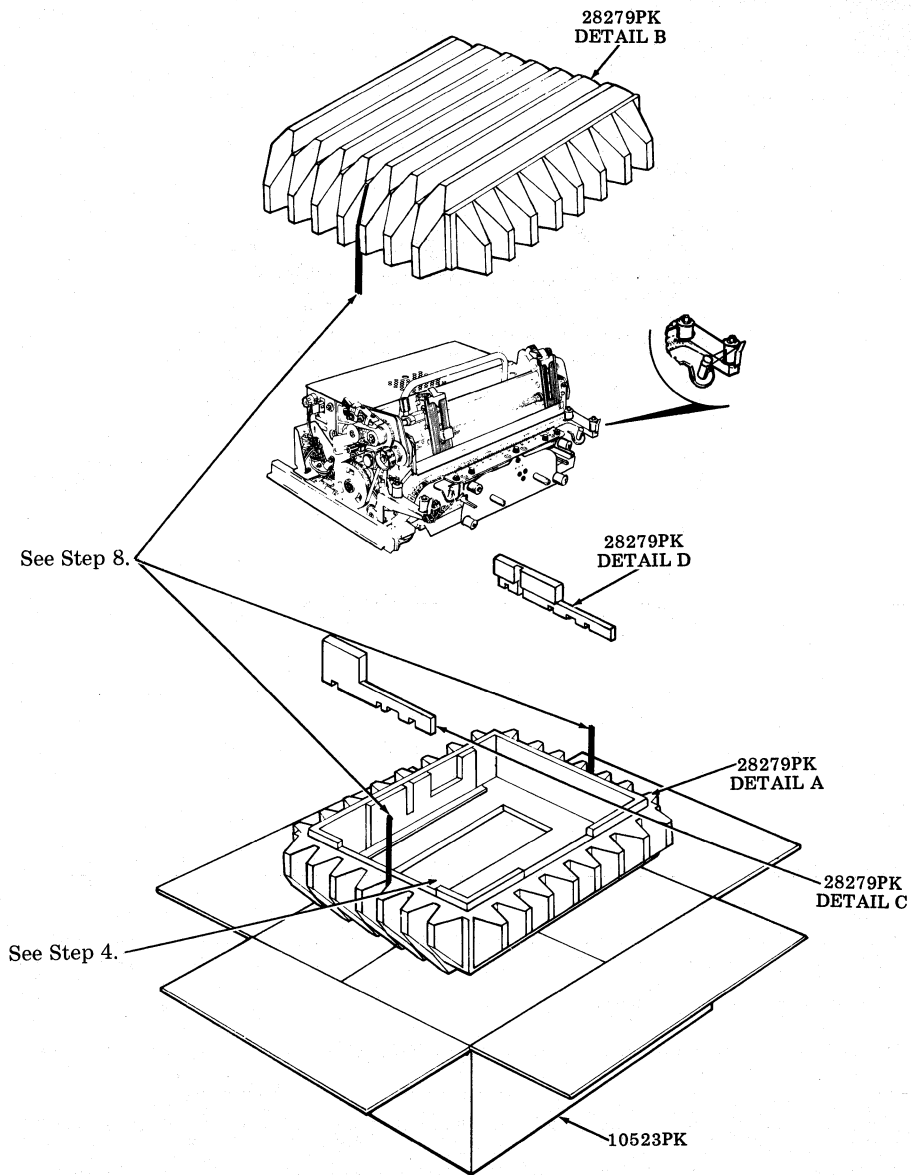

Fig. 16

TRACTOR FEED PRINTER (132-COLUMN)

Packing Procedure for 40P200, 40P201, 40P202, 40P203 and 40P204 Printers

- Step 1. Remove printer from printer cabinet.
- Step 2. Remove ribbon spools from printer and discard.

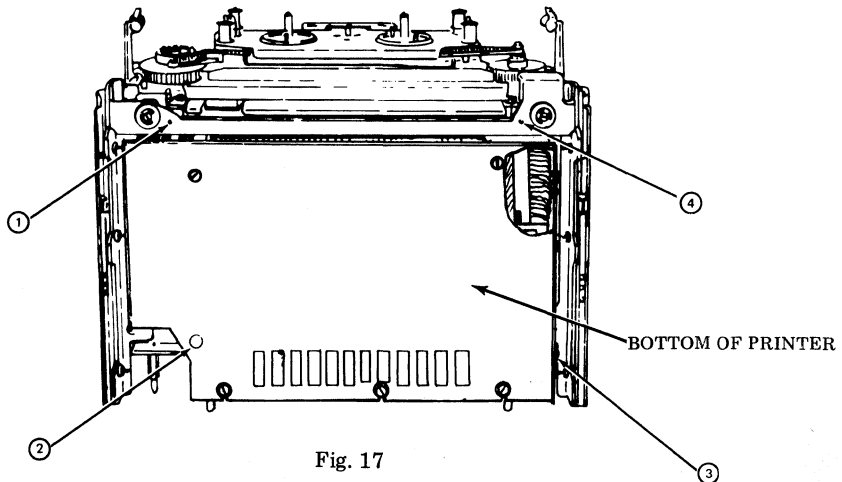

Fig. 17

- Step 3. Position printer on its back. Immobilize unit vibration mounts by tightening the four immobilizing screws. See Fig. 17.
- Step 4. Set unit upright. Secure each of the two ribbon tensioning arms in latched position with 50136PK twist ties.

Caution: Do not tightly apply twist ties. Damage to tensioning arms may result.

- Step 5. Position wood details 28250PK A and B against bottom of unit. Secure in place with two bands of tape 21632PK. See Fig. 18.
- Step 6. Form shipping container 10634PK. Close and seal bottom flaps with glue or sealing tape.
- Step 7. Position a plastic corner 27442PK against each of the four corners of the container. See Fig. 18.
- Step 8. Form carton 9902PK. Close and seal bottom flap as outlined in Step 6. Position carton in shipping container so bottom corners of carton fit in the corner details. See Fig. 18.
- Step 9. Carefully position the prepackaged printer in the carton-container assembly. See Fig. 18.
- Step 10. Position a wood top detail 28252PK over top of printer. See Fig. 18.
- Step 11. Close and seal top flaps of carton, as outlined in Step 6.
- Step 12. Position a 27442PK plastic corner on each of the four corners of the carton. See Fig. 18.
- Step 13. Close and seal top flaps of carton as outlined in Step 6.

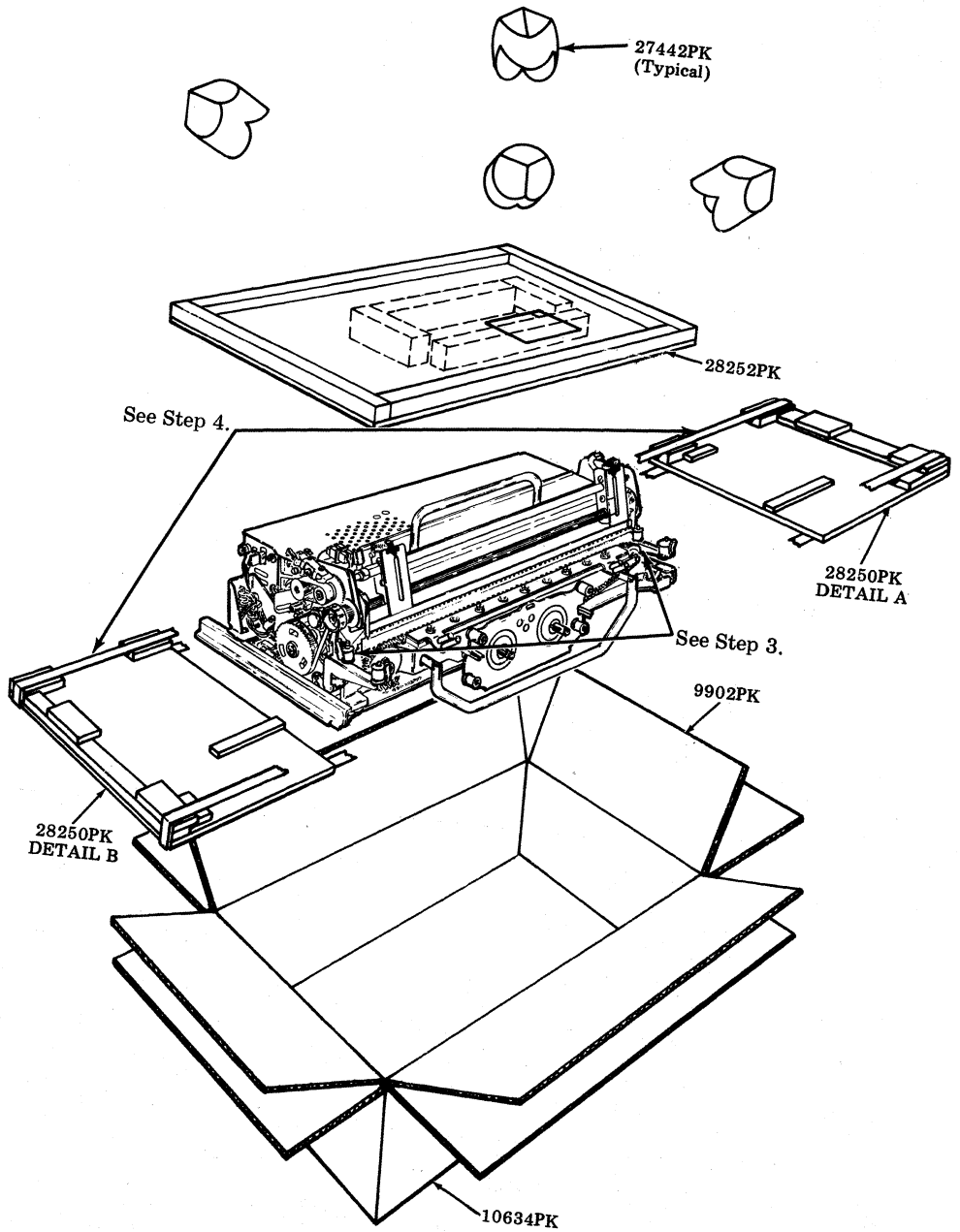

Fig. 16

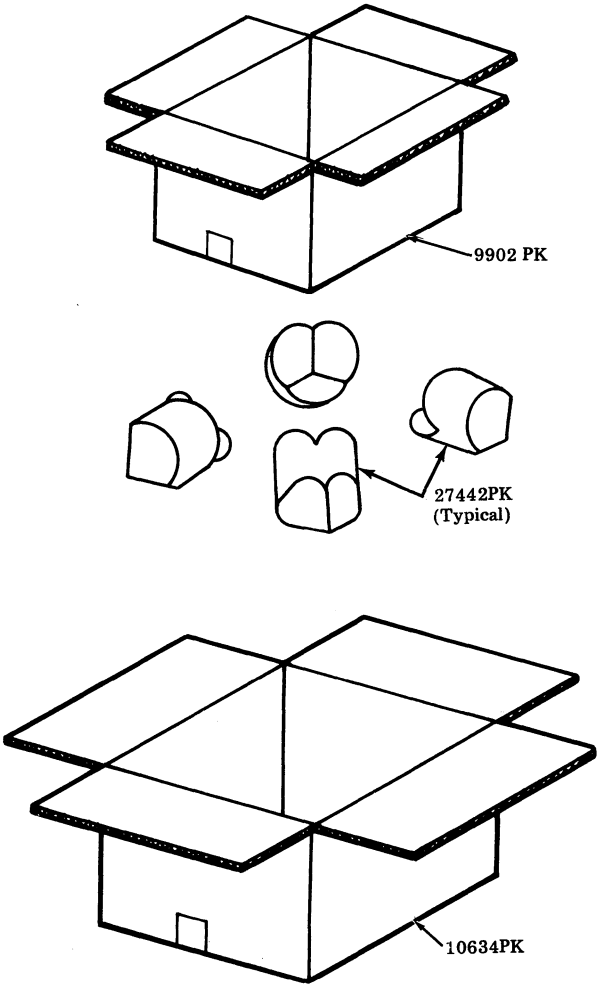

Fig. 19

TRACTOR FEED PRINTER (72-COLUMN)

Packing Procedure for 40P250 (Forms Access) Printer

- Step 1. Remove printer from printer cabinet.
- Step 2. Remove ribbon spools from printer and discard.
- Step 3. Position printer on its back. Immobilize unit vibration mounts by tightening the four immobilizing screws.
- Step 4. Position wood details 28283PK A and B against bottom of unit. Secure in place with two bands of 21632PK tape at front and rear of details.
- Step 5. Form a 10762PK carton. Close bottom flaps and seal center seam with a strip of 21719PK tape. The tape should extend approximately three inches down the ends of the carton.
- Step 6. Place one 27442PK plastic corner in each of the four corners of the bottom of the carton. See Fig. 20.
- Step 7. Form a 10305PK carton. Close and seal bottom flaps as indicated in Step 5.
- Step 8. Carefully place the 10305PK carton in the 10762PK carton so the plastic corners fit in the corners of the 10305PK carton. See Fig. 20.

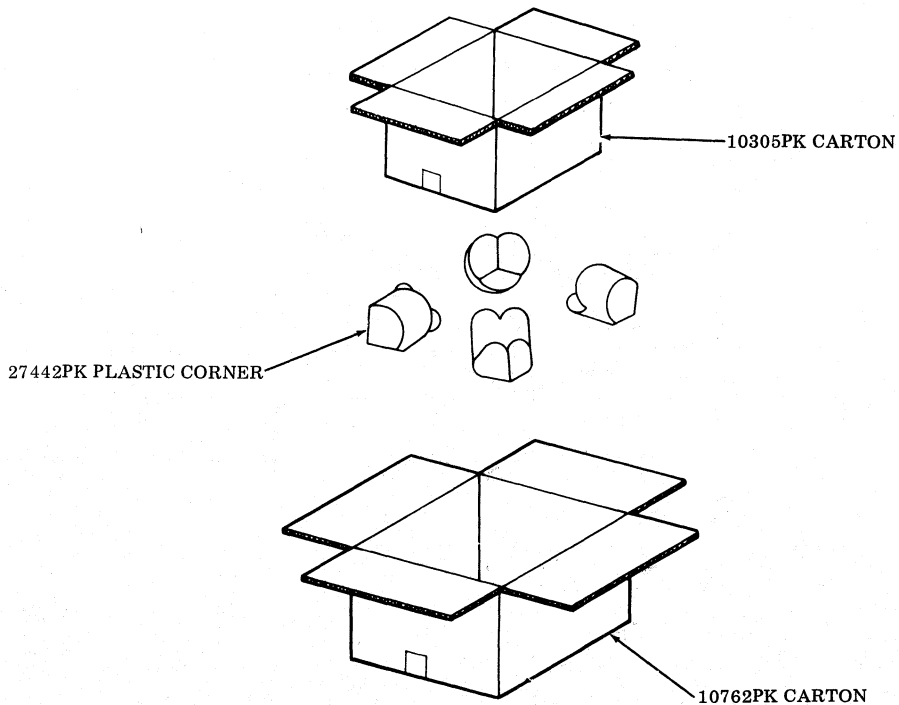

Fig. 20

- Step 9. Place the printer with pallets in the inner carton. See Fig. 21.
- Step 10. Place one 28284PK wood detail in carton on top of printer. See Fig. 21.
- Step 11. Close and seal top flaps of inner carton as indicated in Step 5.
- Step 12. Position a 27442PK plastic corner on each of the four corners of the inner carton. See Fig. 21.
- Step 13. Close top flaps of outer carton and seal center seam with a strip of 21719PK tape as indicated in Step 5.

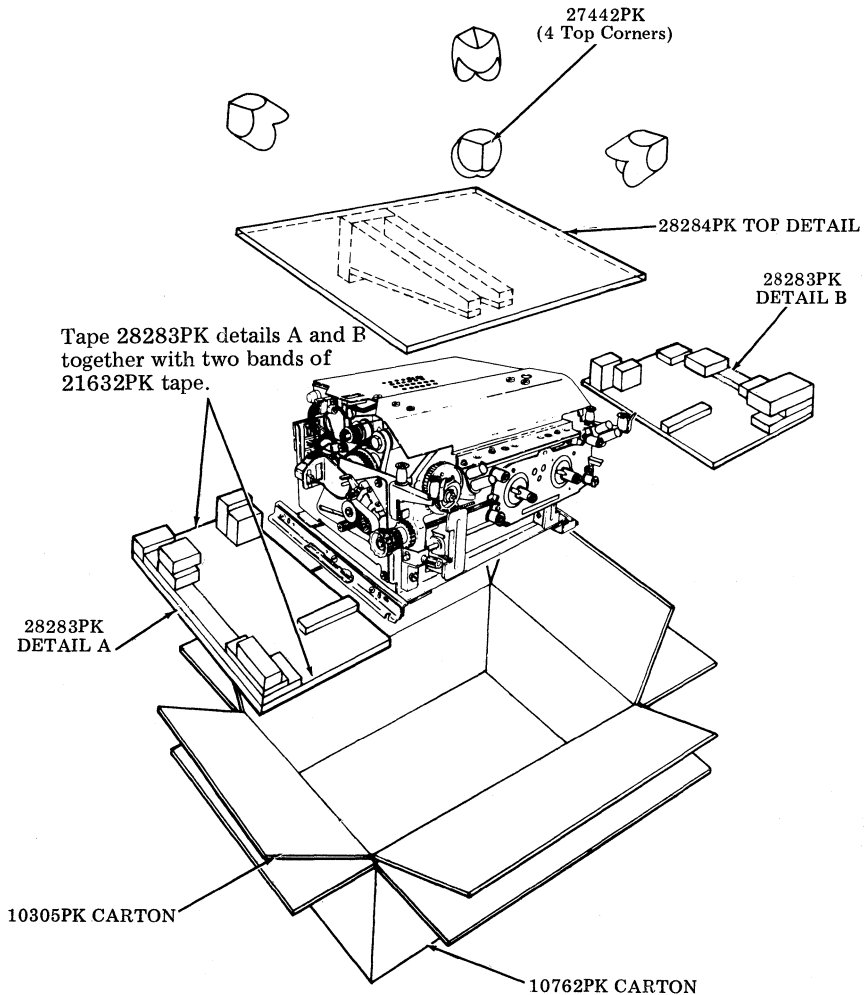

Fig. 21

TRACTOR FEED PRINTER (80-COLUMN, FORMS ACCESS)

Packing Procedure for 40P252, 40P253, and 40P255 (Forms Access) Printers

- Step 1. Remove printer from printer cabinet.
- Step 2. Remove the ribbon spools and discard.
- Step 3. Position printer on its back. Immobilize unit vibration mounts by tightening the four immobilizing screws.
- Step 4. Position wood details 28283PK A and B against bottom of unit. Secure in place with two bands of 21632PK tape at front and rear of details.
- Step 5. Form a 10770PK carton. Close bottom flaps and seal center seam with a strip of 21719PK tape. The tape should extend approximately three inches down the ends of the carton.
- Step 6. Form and place one 28366PK cushion detail in each of two sides of the bottom of the carton. See Fig. 22.
- Step 7. Form a 10305PK carton. Close and seal bottom flaps as indicated in Step 5.
- Step 8. Carefully place the 10305PK carton in the 10770PK carton so the cushion details fit in the corners of the 10305PK carton. See Fig. 22.
- Step 9. Place the printer with pallets in the inner carton.
- Step 10. Place a 28284PK wood detail in carton on top of printer. See Fig. 23.
- Step 11. Close and seal top flaps in inner carton as indicated in Step 5.
- Step 12. Form and place a 28366PK cushion detail on each of two sides of the inner carton. See Fig. 22.
- Step 13. Close top flaps of outer carton and seal center seam with a strip of 21719PK tape as indicated in Step 5.

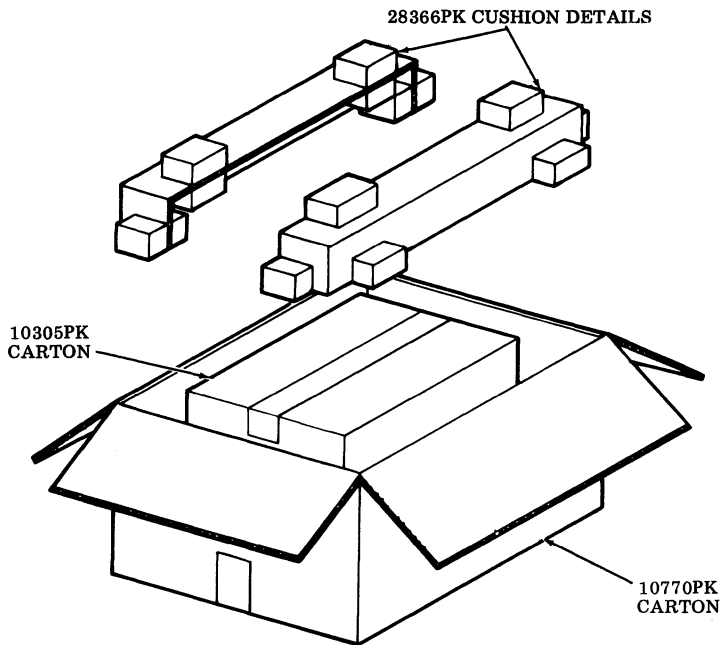

Fig. 22

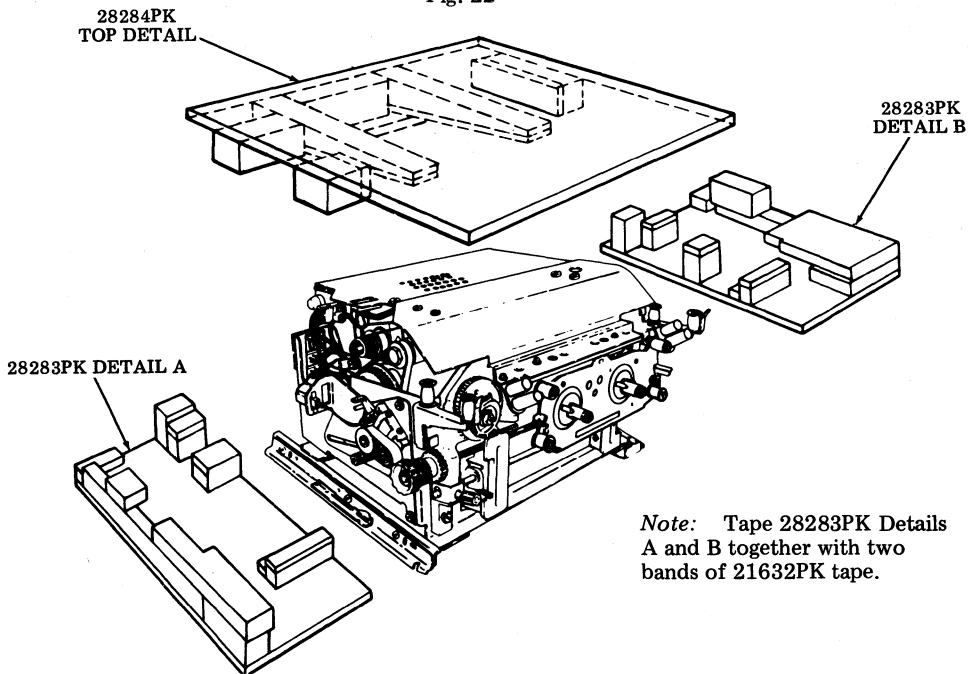

Fig. 23

40CAB201 AND 40CAB251 CABINETS

Packing Procedures

- Step 1. Form a 9867PK carton. Close and seal bottom flaps with glue or sealing tape.
- Step 2. Make certain shipping latches and bar on cabinet are properly installed. Cover cabinet with 23457PK plastic bag.
- Step 3. Position a plastic 28218PK Detail A on right side of cabinet. (See Fig. 24).
- Step 4. Position a plastic 28218PK Detail B on left side of cabinet. (See Fig. 24).
- Step 5. Coil cable on top of cabinet and position prepacked cabinet in shipping container. (See Fig. 24).
- Step 6. Close and seal top flaps of shipping container as outlined in Step 1.

Note: 40CAB201 series is pictured.

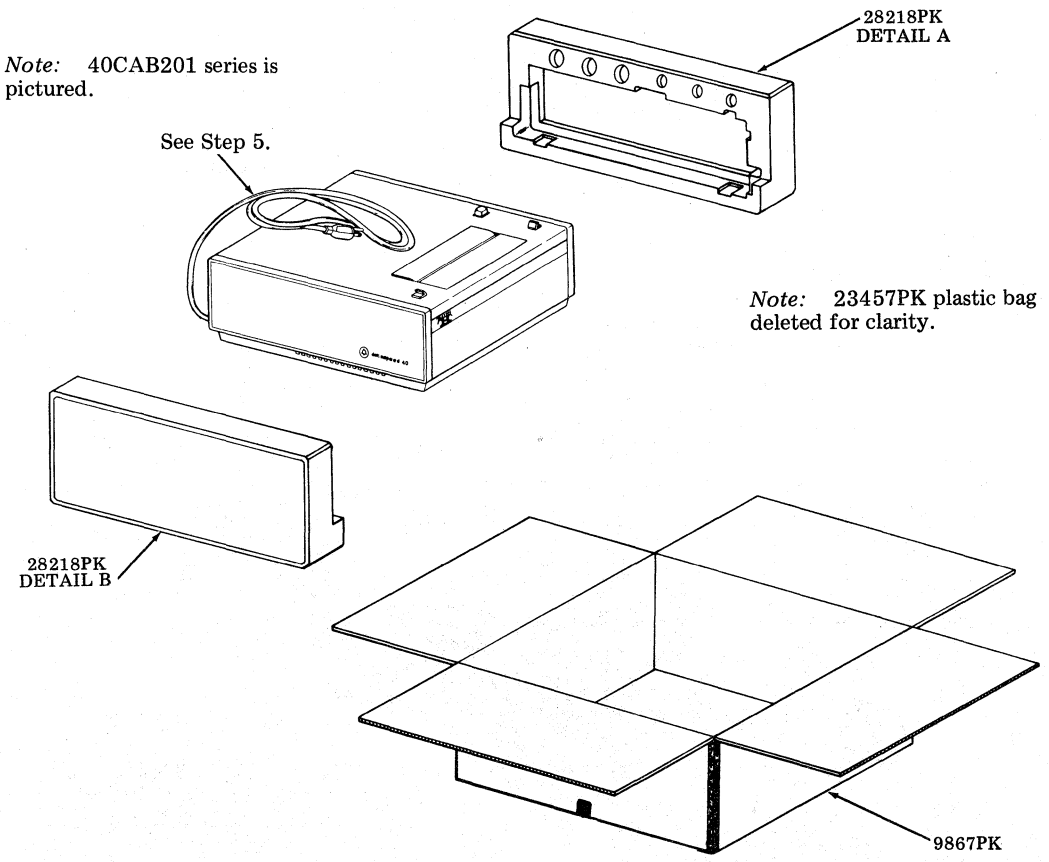
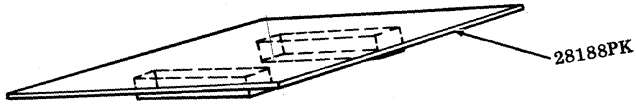

Fig. 24

40CAB351 AND 40CAB371 CABINETS

Packing Procedure for 40CAB351 Cabinet and 40CAB371 Cabinet

- Step 1. Place a 28186PK detail on work bench. Position cabinet on detail as illustrated in Fig. 25. The end of the detail that has the largest blocks must be to the front of the cabinet.
- Step 2. Secure cover of cabinet with two bands of 21632PK tape applied around cover and body of cabinet. See Fig. 25.
- Step 3. Place a 23457PK plastic bag over cabinet. Leave cable extending outside of bag. Place cable on top of cabinet.
- Step 4. Fold flaps on 28186PK detail up against sides of cabinet. Secure in place with a strip of 21480PK tape applied to flaps at diagonally opposite corners.
- Step 5. Form a 10532PK carton. With bottom flaps down and outward, place carton around cabinet and detail. Drape cable outside of carton.
- Step 6. Form a 28187PK detail and place in carton around cabinet dome. See Fig. 25. Coil cable and place between side of carton and 28187PK detail. See Fig. 25.
- Step 7. Place a 28188PK detail in carton as illustrated in Fig. 25.
- Step 8. Close top flaps of carton and seal center seam with 21719PK tape. Invert carton.
- Step 9. Close bottom flaps of carton and seal as outlined in Step 8. Invert carton.



Note: 23457PK plastic bag deleted for clarity.

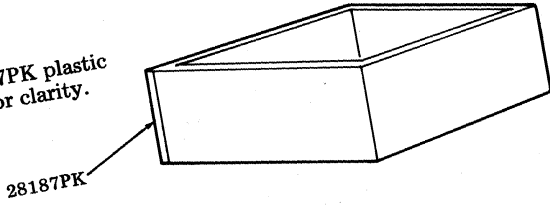

Coil cable and place between side of 28187PK detail and carton wall.

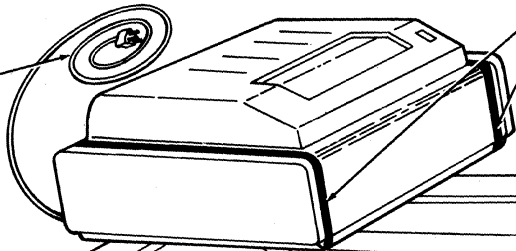

Secure cover with 2 bands of 21632PK tape applied around cabinet, as shown.

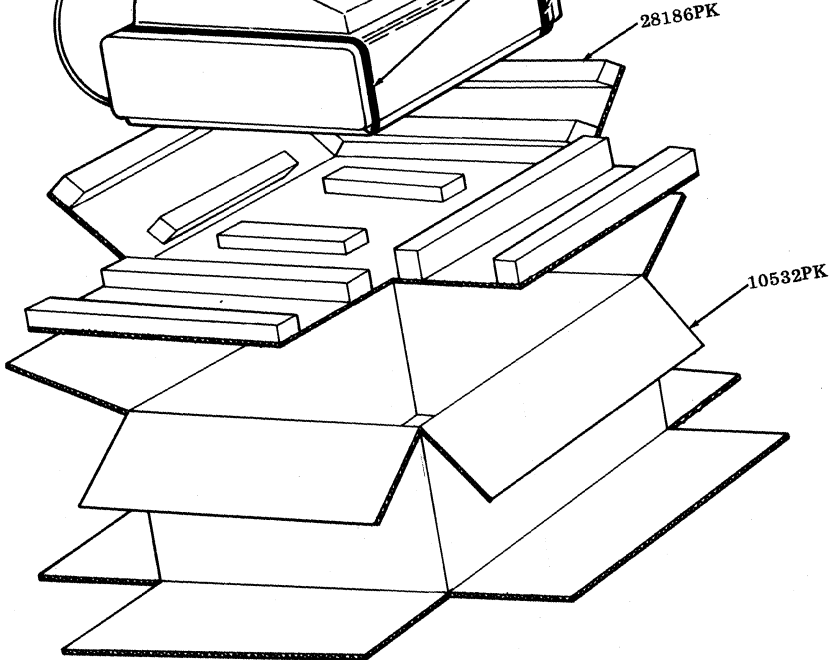

Fig. 25

40CAB353 CABINET**Packing Procedure for 40CAB353 Cabinet**

- Step 1. Secure cover of cabinet with two strips of 21632PK tape. Follow contour of cabinet. (See Fig. 26).
- Step 2. Place a 23461PK plastic bag over cabinet. Leave cable extending outside of bag. Place cable on top of cabinet.
- Step 3. Form a 10672PK carton. Close and seal bottom flaps with 21719PK tape. Apply one strip on the center seam and a strip on each of the end seams.
- Step 4. Form a 28224PK detail and place in carton. See Fig. 26.
- Step 5. Center cabinet in carton left to right. Butt back of cabinet against the plastic blocks.
- Step 6. Position a 28225PK detail along each side and front of cabinet. See Fig. 26.
- Step 7. Extend cable outside of cabinet. Form and place a 28227PK liner on cabinet dome. See Fig. 26.
- Step 8. Coil cable and place in recess formed by the 28227PK liner and carton wall.
- Step 9. Place a 28226PK detail in carton as illustrated in Fig. 26.
- Step 10. Close and seal top flaps of carton as outlined in Step 3.

Note: 23461PK plastic bag deleted for clarity.

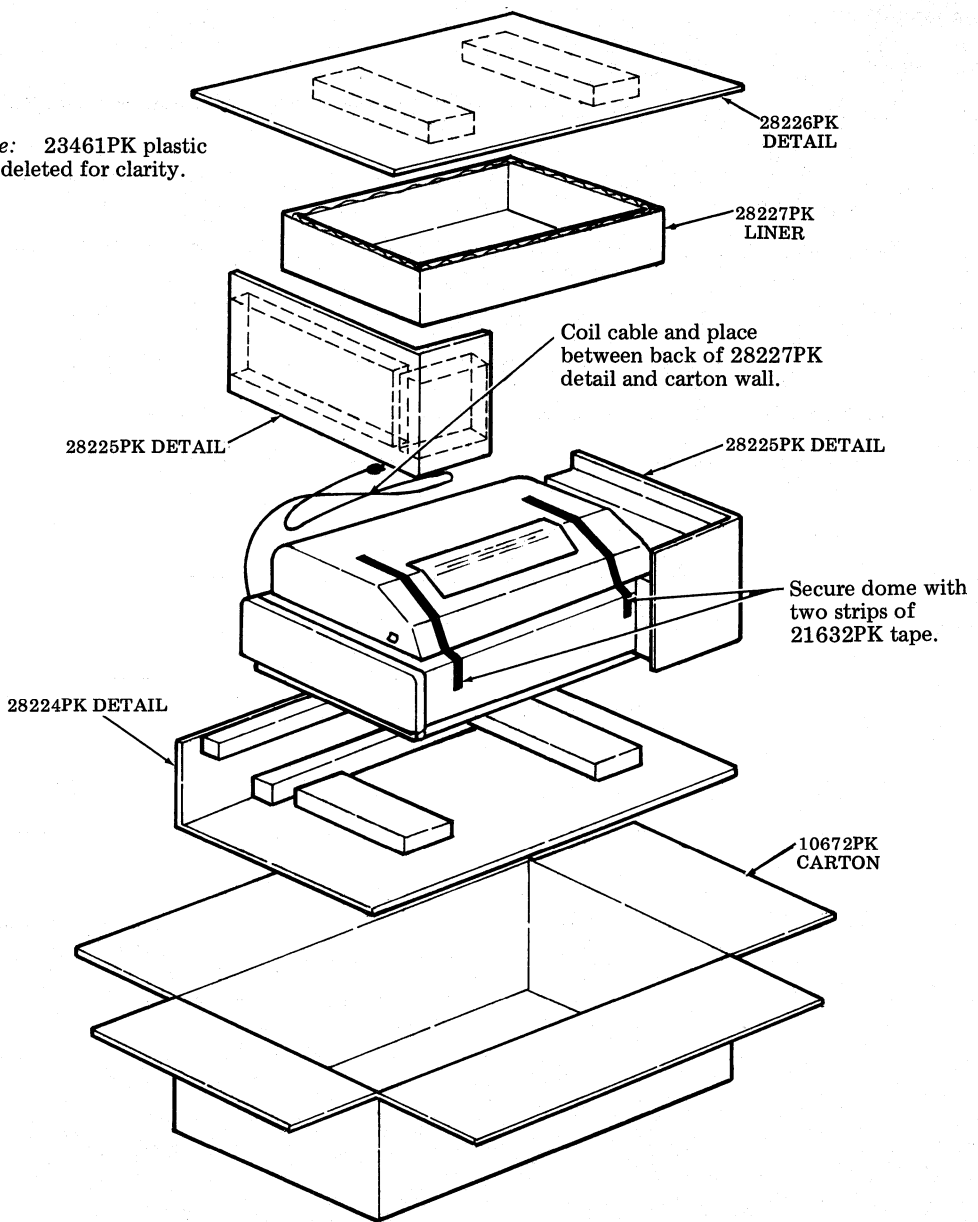

Fig. 26

40CAB901 CABINET

Packing Procedure for 40CAB901 Pedestal With Table Top

- Step 1. Open door in bottom of pedestal (when equipped). Secure line cord (if equipped) to line cord holding brackets with 50136PK twist ties. Place cord in bottom of pedestal.
- Step 2. Close door. Close latches located at either end on top of door.
- Step 3. Place a 23461PK plastic bag around unit.
- Step 4. Place container base (RS-18238-J) on floor as shown.
- Step 5. Position pedestal in container base cutouts.
- Step 6. Form and position side details (RS-18238-K left and right) to pedestal.
- Step 7. Form a RS-18238-H container body and position over pedestal. Secure base with nylon reinforced tape. Standard procedure is to apply a band of steel strapping around the base of the container.

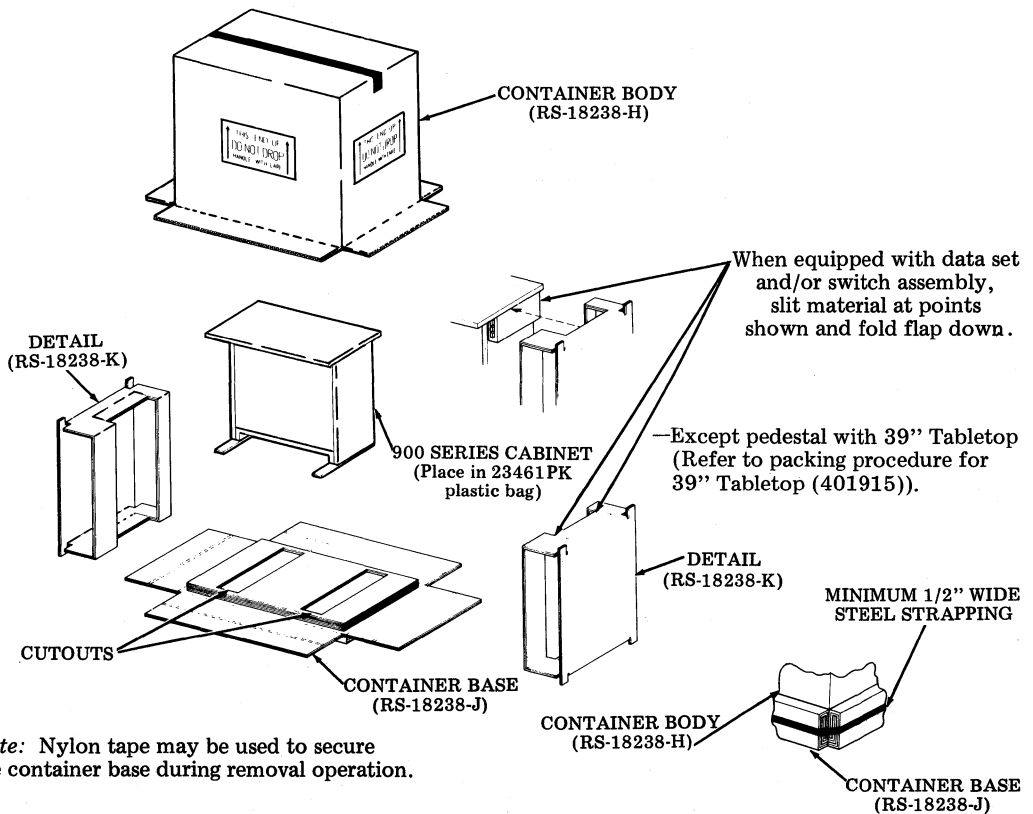

Fig. 27

Packing Procedure for 20 inch Tabletop (401911)

- Step 1. Place tabletop in a 23457PK plastic bag.
- Step 2. Form a 8565PK folder. Center top in folder. Place a 28214 wood detail at either end of top as illustrated.
- Step 3. Fold tabs on inner flaps of folder as illustrated.
- Step 4. Close flaps and seal center seam with 21719PK tape.

Note: Packing procedure and packing materials for 24 inch tabletops (401531 and 401914) are identical to (401911) except that 28214PK wood details are not required in (401531 and 401914).

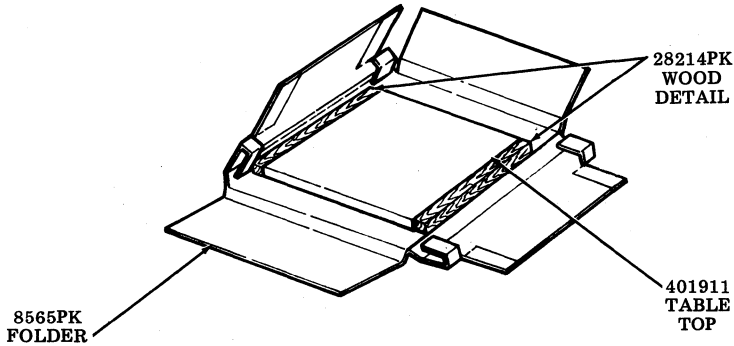

Fig. 28

Packing Procedure for 27 1/2 inch Tabletop (401913)

- Step 1. Place tabletop in a 23451PK plastic bag.
- Step 2. Form a 8564PK folder. Center top and a 28254PK wood detail in folder. Fold tabs on inner flaps of folder as illustrated.
- Step 3. Close flaps and seal center seam with 21719PK tape.

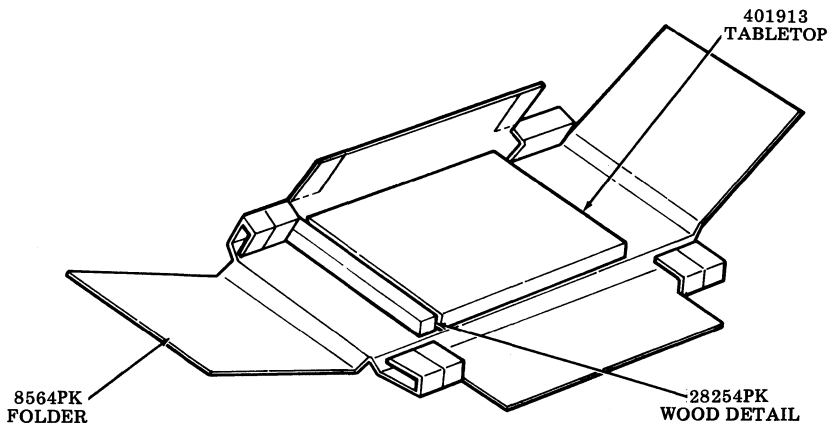

Fig. 29

Packing Procedure for 29 inch Tabletops (401532 and 411035)

- Step 1. Place tabletop in a 23451PK plastic bag.
- Step 2. Form a 8564PK folder. Center top in folder. Fold tabs on inner flaps of folder as illustrated.
- Step 3. Close flaps and seal center seam with 21719PK tape.

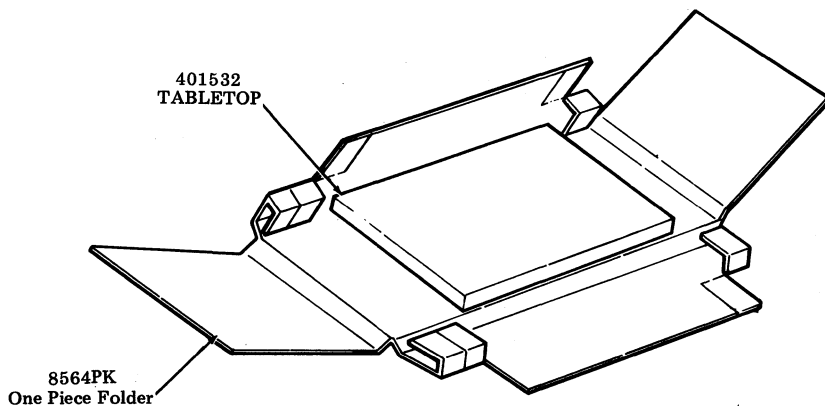

Fig. 30

Packing Procedure for 31 inch Tabletop (401912)

- Step 1. Place tabletop in a 23451PK plastic bag.
- Step 2. Form a 8564PK folder. Position top in folder. Fold tabs on inner flaps of folder as illustrated.
- Step 3. Close flaps and seal center seam with 21719PK tape.

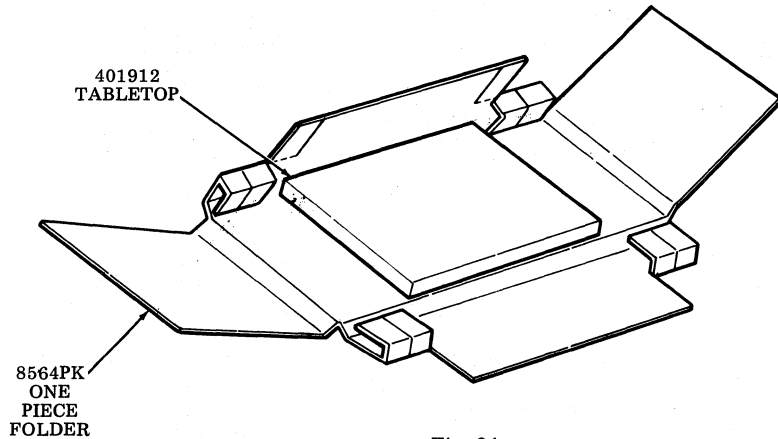

Fig. 31

Packing Procedure for 34 inch Tabletop (401533)

- Step 1. Place tabletop in a 23451PK plastic bag.
- Step 2. Form a 8564PK folder. Center top in folder. Fold tabs on inner flaps of folder as illustrated.
- Step 3. Close flaps and seal center seam with 21719PK tape.

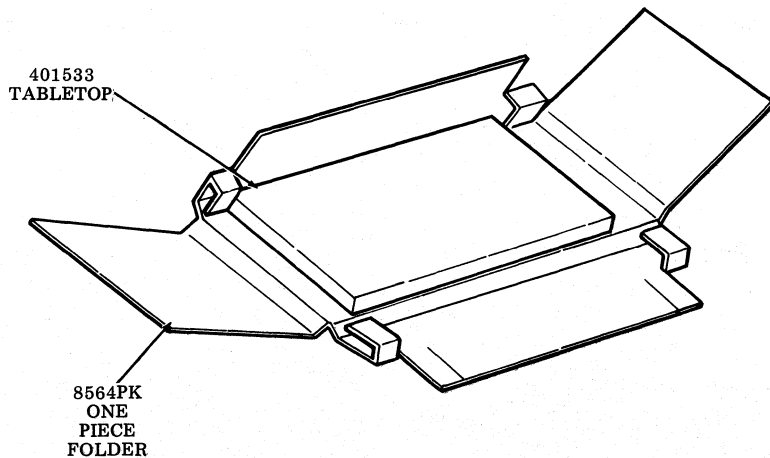

Fig. 32

Packing Procedure for 39 inch Tabletop (401915)

- Step 1. Place tabletop in a 23464PK plastic bag.
- Step 2. Form a 8573PK two piece folder. Center top upside down in folder. Place a 28214PK wood detail at either end of top as illustrated.
- Step 3. Close flaps and seal center seam with 21719PK tape.

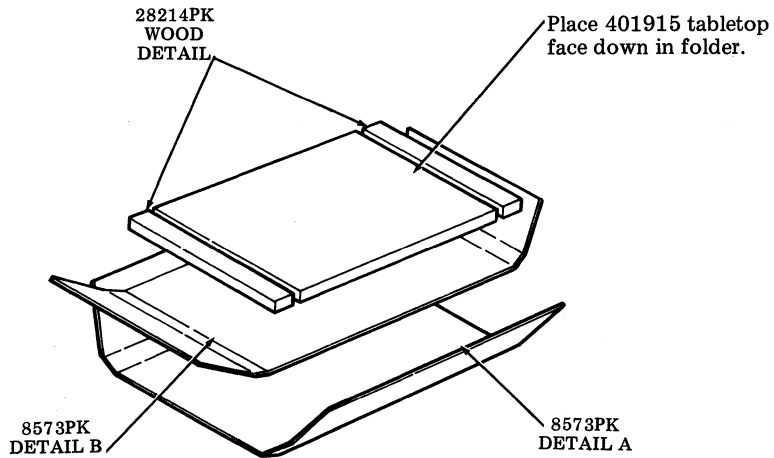

Fig. 33

Packing Procedure for 40CAB901 Pedestal Without Tabletop

- Step 1. Open door in bottom of table (when equipped). Secure line cord (if equipped) to line cord holding brackets with 50136PK twist ties.
- Step 2. Close door. Close latches located at either end at top of door.
- Step 3. Secure bag of parts in recess at upper right front corner of cabinet with a strip of 21632PK tape. Cover cabinet with a 23461PK plastic bag.
- Step 4. Place a 70133PK Detail B end cap on floor.
- Step 5. Position cabinet on top of bottom end cap.
- Step 6. Lift left side of cabinet and place a 28253PK Detail A onto the left foot. Set cabinet with detail back down on end cap.
- Step 7. Lift right side of cabinet and place a 28253PK Detail B onto right foot as indicated in Step 6.
- Step 8. Place a 28253PK Detail C on left top corner of the cabinet. See Fig. 34.
- Step 9. Place a 28253PK Detail C on right top corner of the cabinet. See Fig. 34.
- Step 10. Form one 70133PK Detail A and with bottom flanges down and outward, place over top of cabinet and details and slide to bottom.
- Step 11. Interlock flanges of bottom end cap with corrugated carton flanges. Apply a band of 21207PK strapping around the center of flanges of end cap. Seal strapping with one 21431PK clip seal. The tension of strapping should be sufficiently tight to bite into corners so that strapping will not shift.
- Step 12. Close top flaps of carton and seal center seam with a strip of 21719PK tape. The tape should extend approximately three inches down the sides of the carton.

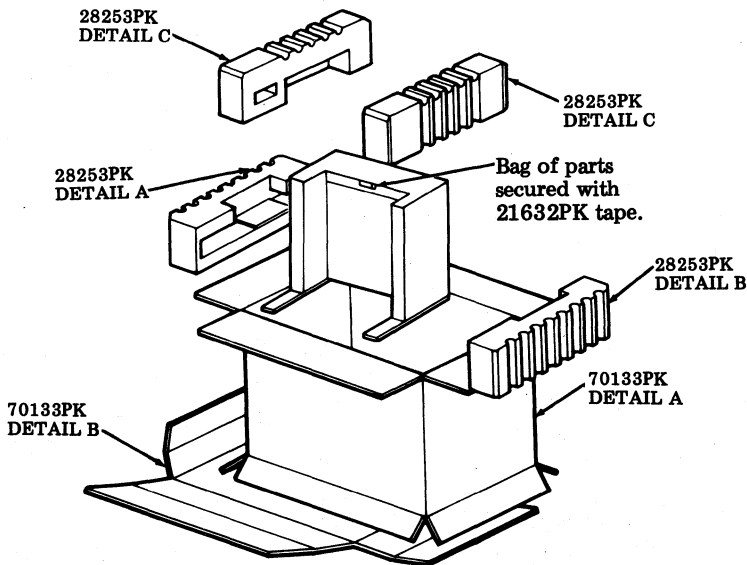

Fig. 34

Packing Procedure for 40CAB901 Pedestal Without Table Top and Feet

- Step 1. Open door in bottom of table (when equipped). Secure line cord (if equipped) to line cord holding brackets with 50136PK twist ties.
- Step 2. Close door. Close latches located at either end at top of door.
- Step 3. Secure muslin bag of parts to top of cabinet with two strips of 21632PK tape. Cover cabinet with a 23461PK plastic bag.
- Step 4. Form a 11946PK carton. With bottom flaps down and outward, place carton around cabinet.
- Step 5. Place a 27442PK plastic corner on each of the four corners of the cabinet top. See Fig. 35.
- Step 6. Close and seal top flaps of carton. Seal the center seam with a strip of 21719PK tape. The tape should extend approximately three inches down the ends of the carton. Invert carton.
- Step 7. Place a 27442PK plastic corner on each of the four corners of the cabinet bottom.
- Step 8. Close and seal the bottom flaps of the carton as outlined in Step 6. Invert carton.

Note: 23461PK plastic bag deleted for clarity.

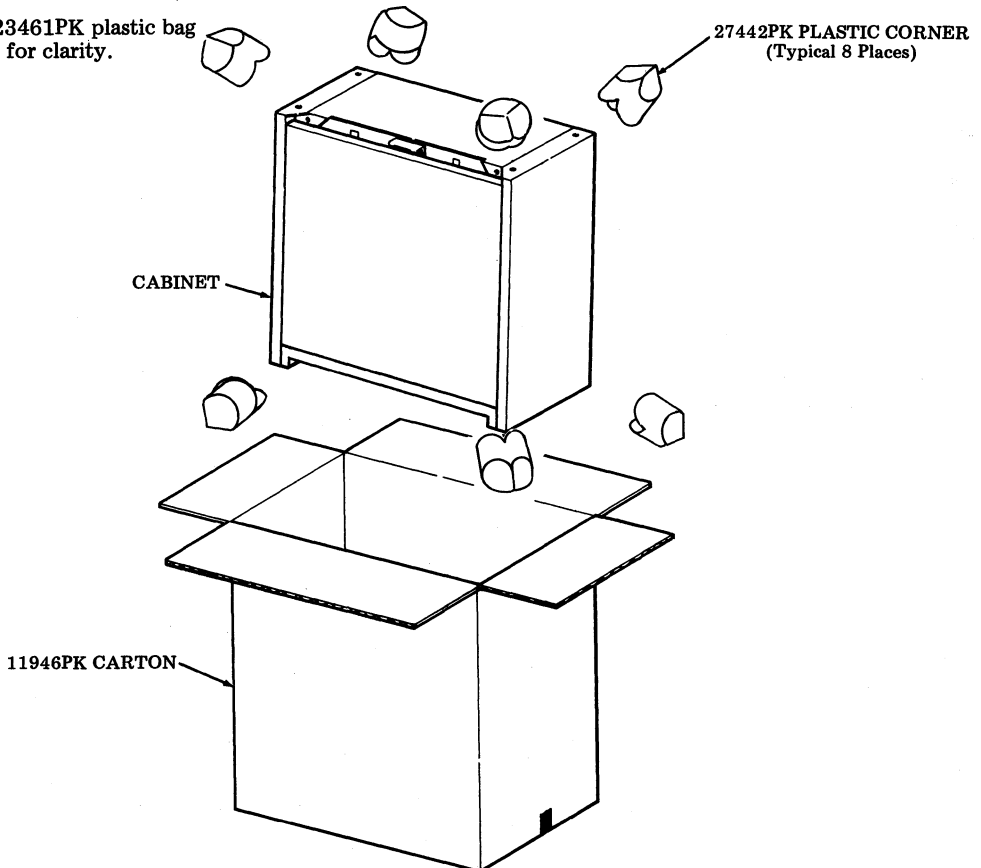

Fig. 35

40CAB902 CABINET

Packing Procedure for 40CAB902 Cabinet

- Step 1. Open door in bottom of table (when equipped). Secure line cord (if equipped) to the line cord holding brackets with 50136PK twist ties. Close door. Close latch located at either end at top of door.
- Step 2. Cover cabinet with a 23461PK plastic bag (not shown).
- Step 3. Place one 70144PK Detail B end cap on floor.
- Step 4. Position cabinet on top of bottom end cap.
- Step 5. Lift left side of cabinet and place a 28253PK Detail A onto the left foot. Set cabinet with detail back down on end cap.
- Step 6. Lift right side of cabinet and place a 28253PK Detail B onto the right foot as indicated in Step 5.
- Step 7. Place a 28253PK detail on left and right top corner of the cabinet. See Fig. 36.
- Step 8. Form a 70144PK carton Detail A and with bottom flanges down and outward, place carton over top of cabinet and details and slide to bottom.
- Step 9. Interlock flanges of bottom end cap with corrugated carton flanges. Standard procedure is to apply a band of 21207PK strapping around center of flanges of end cap. For standard removal, use nylon reinforced tape.
- Step 10. Close top flaps of carton and seal center seam with a strip of 21719PK tape. The tape should extend approximately three inches down the sides of the carton.

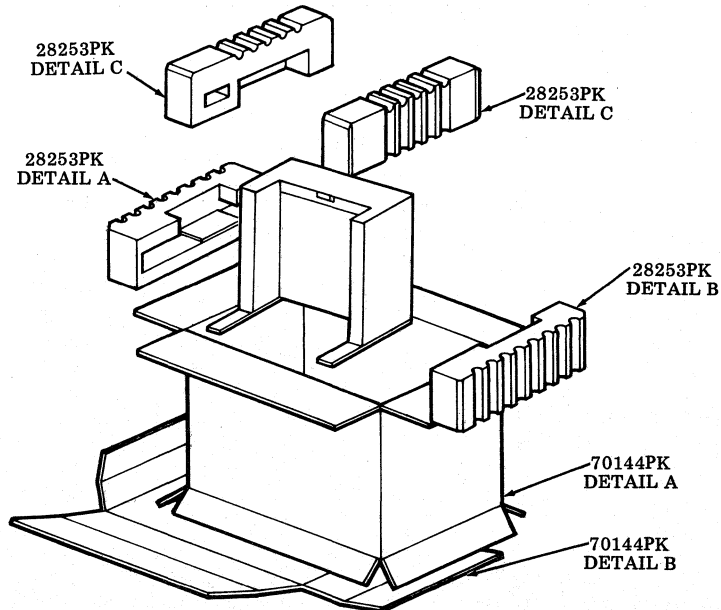

Fig. 36

40CAB904 CABINET

Packing Procedure for 40CAB904 Cabinet

- Step 1. Open door in bottom of pedestal (when equipped). Secure line cord (if equipped) to line cord holding brackets with 50136PK twist ties.
- Step 2. Close door. Close latches located at either end of top of door.
- Step 3. Secure bag of parts in recess at upper right front corner of cabinet with a strip of 21632PK tape (see Fig. 37). Cover cabinet with a 23461PK plastic bag.
- Step 4. Form a 28223PK detail. Tape folds of detail together with two strips of 21719PK tape. Secure to cabinet legs with a strip of 21632PK tape. See Fig. 37.
- Step 5. Position a 28185PK Detail A on left leg and a 28185PK Detail B on right leg of pedestal. See Fig. 37.
- Step 6. Form details against sides and back of pedestal and secure in place with a strip of 21632PK tape. See Fig. 37.
- Step 7. Form a 12005PK carton, and with bottom flaps down and outward, place around cabinet and details.
- Step 8. Form a 28185PK Detail B and place it on left top corner of the cabinet. See Fig. 37.
- Step 9. Form a 28185PK Detail A and place it on right top corner of the cabinet. See Fig. 37.
- Step 10. Close top flaps of carton and seal center seam with a strip of 21719PK tape. The tape should extend approximately three inches down the sides of the carton. Carefully invert carton.
- Step 11. Close bottom flaps of carton and seal as outlined in Step 10. Carefully invert carton.

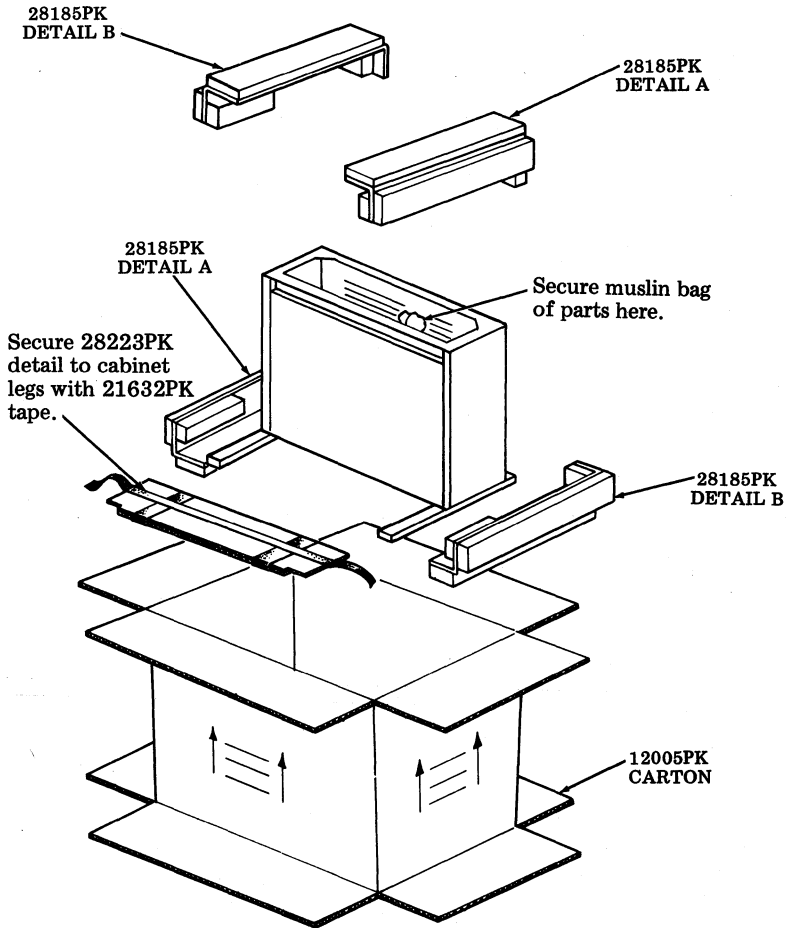

Fig. 37

40CAB302 CABINET

Packing Procedure for 40CAB302 Cabinet

- Step 1. Place skidded bottom end cap Detail A of 16937PK details on floor. See Fig. 38.
- Step 2. Place and center the bottom cushion cap Detail B of 16937PK details on top of A. See Fig. 38.
- Step 3. Place the cabinet on Detail B with the rear edge of the legs in line with the rear edge of the built up pads.
- Step 4. Place a 23461PK plastic bag over top of cabinet. Cover bottom of cabinet with sheets of 21298PK tissue and tape to cabinet with 21480PK tape.
- Step 5. Coil cable at bottom of cabinet and tape to cabinet with 21632PK tape.
- Step 6. Fold the flaps of the bottom cushion cap Detail B against the plastic enclosed cabinet. Tape the flaps against the cabinet with a complete band of 21632PK tape. Make sure cable is not pinched between flap and cabinet.
- Step 7. Form a 16937PK carton Detail D and with bottom flanges down and outward, place over top of cabinet and detail and slide to bottom. See Fig. 38.
- Step 8. Form and place one top cushion cap Detail C of 16937PK within carton on top of cabinet. The portion of the detail without a corrugated block must be placed to the front of the cabinet. See Fig. 38.
- Step 9. Interlock flanges of bottom end cap with corrugated carton flanges. Standard procedure is to apply a band of 21207PK strapping around center of flanges of end cap. For standard removal, use nylon reinforced tape.
- Step 10. Close top flaps of carton and seal center seam with a strip of 21719PK tape. The tape should extend approximately three inches down the sides of the carton.

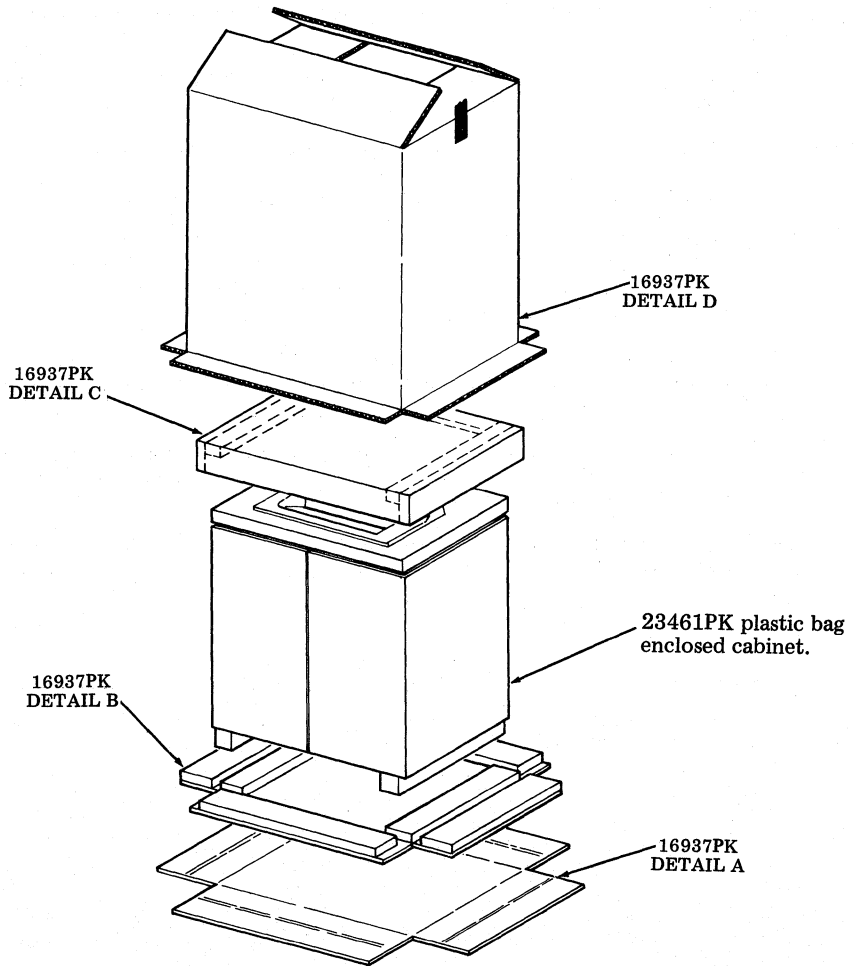

Fig. 38

40AB101 ANSWER-BACK

Packing Procedure for 40AB101 Answer-Back

- Step 1. Remove answer-back from station.
- Step 2. Form a 28203PK corrugated detail and position against answer-back as illustrated in Fig. 39. The tabs on the ends of the detail must be positioned in the slots on either end of the answer-back.
- Step 3. Place answer-back with detail in a 23465PK plastic bag (not shown in illustration).
- Step 4. Form a 9022PK carton. Close bottom flaps and seal with a strip of 21719PK tape applied to the center seam. The tape should extend approximately three inches down the ends of the carton.
- Step 5. Center prepacked answer-back unit in carton as shown.
- Step 6. Form a 28204PK detail and place in carton on top and sides of unit as illustrated.
- Step 7. Coil the cable in the void formed by the 28204PK detail. Fill void space with 21298PK tissue paper (not shown in illustration).
- Step 8. Close and seal top flaps of carton as outlined in Step 4.

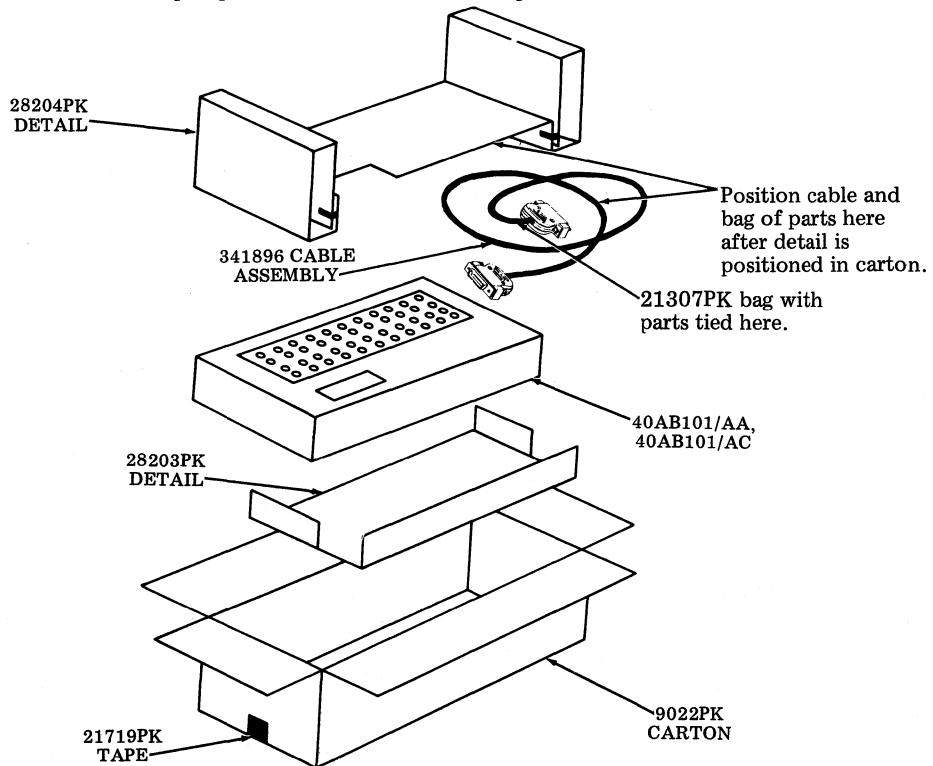

Fig. 39

40BSE101 CIRCULAR BASE

Packing Instructions for 40BSE101 Circular Base

- Step 1. Form shipping container 8956PK. Close and seal bottom flaps with glue or 2 inch minimum width sealing tape.
- Step 2. Place unit in a 23457PK plastic bag.
- Step 3. Form 28206PK detail around unit as illustrated in Fig. 40.
- Step 4. Place unit and detail in carton. See Fig. 40.
- Step 5. Close and seal top flaps of container as outlined in Step 1.

Note: 23457PK plastic bag deleted for clarity.

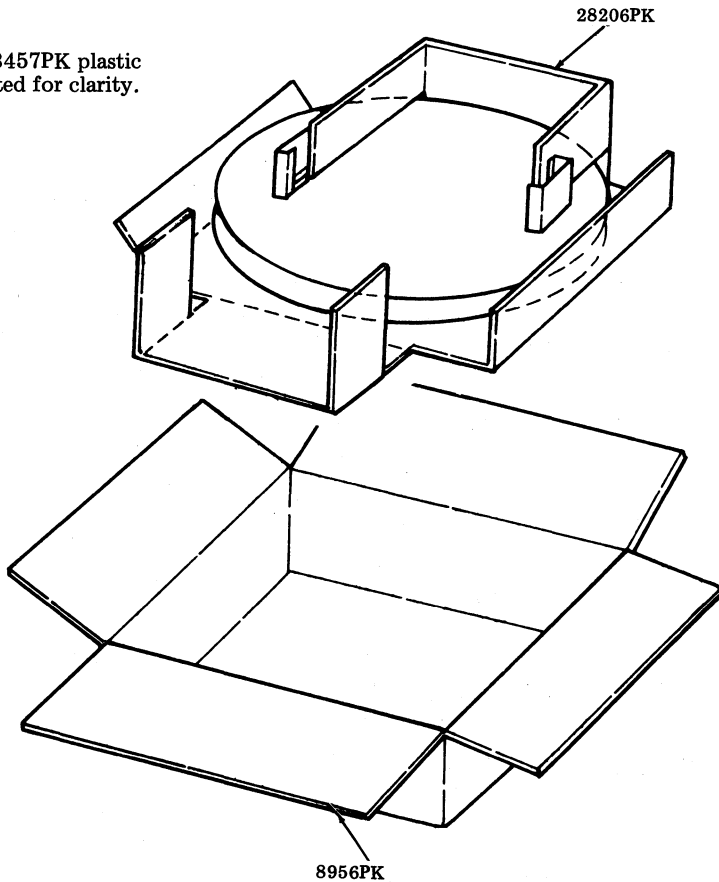

Fig. 40

40BSE201 OPERATOR CONSOLE BASE**Packing Instructions for 40BSE201 Operator Console Base**

- Step 1. Form 9022PK shipping container. Close and seal bottom flaps with glue or 2 inch minimum width sealing tape.
- Step 2. Place unit in a 23456PK plastic bag (not shown).
- Step 3. Form detail 28208PK around unit as illustrated in Fig. 41.
- Step 4. Place unit and detail in carton. See Fig. 41.
- Step 5. Close and seal top flaps of container as outlined in Step 1.

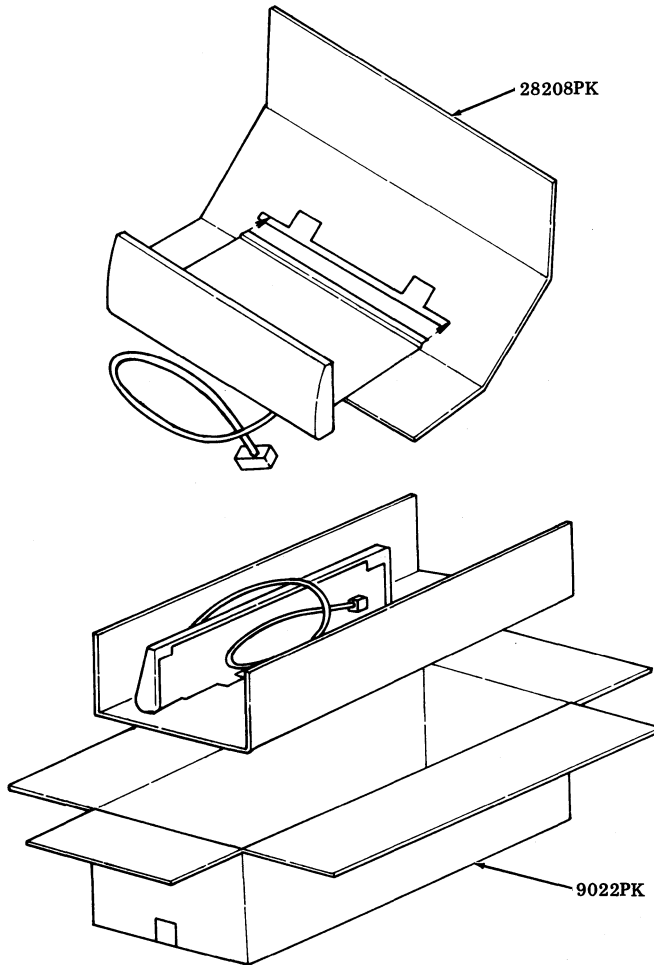

Fig. 41

40BSE202 OPERATOR CONSOLE BASE

Packing Instructions For 40BSE202 Operator Console Base

- Step 1. Form a 28329PK detail. Slide unit base in slot in detail as illustrated in Fig. 42. Secure base of unit to bottom of detail with two strips of 21632PK tape. Buff tape firmly.
- Step 2. Form a 9255PK carton. Close and seal bottom flaps with a strip of 21719PK tape. The tape should extend approximately three inches down the ends of the cartons.
- Step 3. Position unit and detail in carton. Nest cable in 21298PK tissue. Fill all void space with tissue.
- Step 4. Fold detail over to form tray at top. Wrap cover assembly in 21298PK tissue and place in tray. Fill void space with tissue.
- Step 5. Close and seal top flaps of carton as outlined in Step 3.

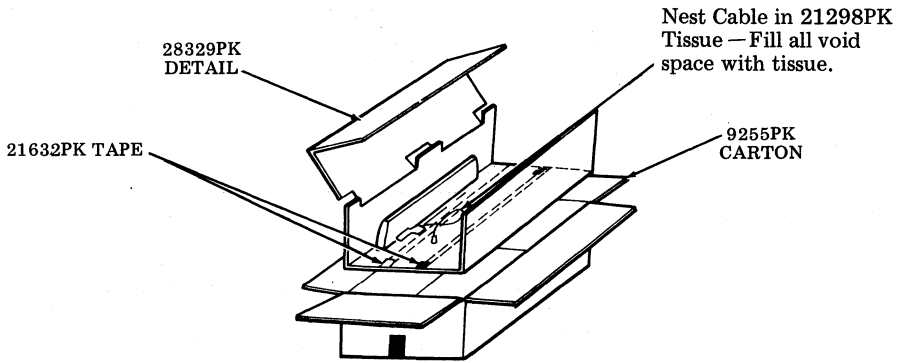

Fig. 42

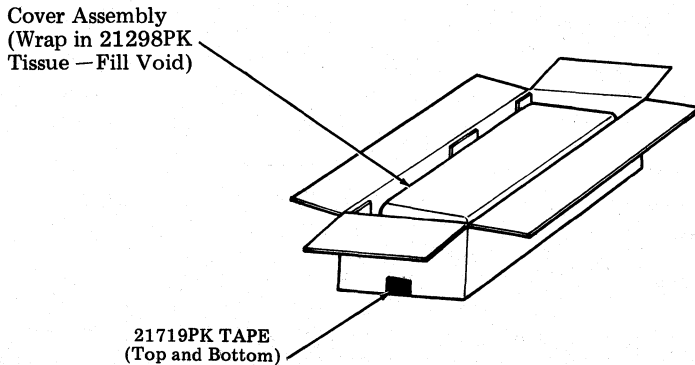

Fig. 43

40/9140 STATION CONTROLLER

Packing Procedure for 9140 Station Controller

- Step 1. Remove 9140 station controller from unit.
- Step 2. Place loose parts in a RM652472 cloth bag. Tie securely.
- Step 3. Position the unit on a 27708PK plywood pallet. Secure unit to pallet with four 28055PK wood screws. (See illustration.)
- Step 4. Coil cable. Place bag of parts in center of coil and secure to end of unit with 21632PK tape.
- Step 5. Form a 9785PK shipping container. Close and seal bottom flaps with glue or sealing tape.
- Step 6. Place a polystyrene 21690PK corner on each of the four corners of the shipping container.
- Step 7. Place a palletized unit in container between the plastic details.
- Step 8. Position a 27711PK liner over the palletized unit.
- Step 9. Form and position a corrugated 28161PK detail in container as illustrated in Fig. 44.
- Step 10. Close and seal top flaps of shipping container as outlined in Step 5.

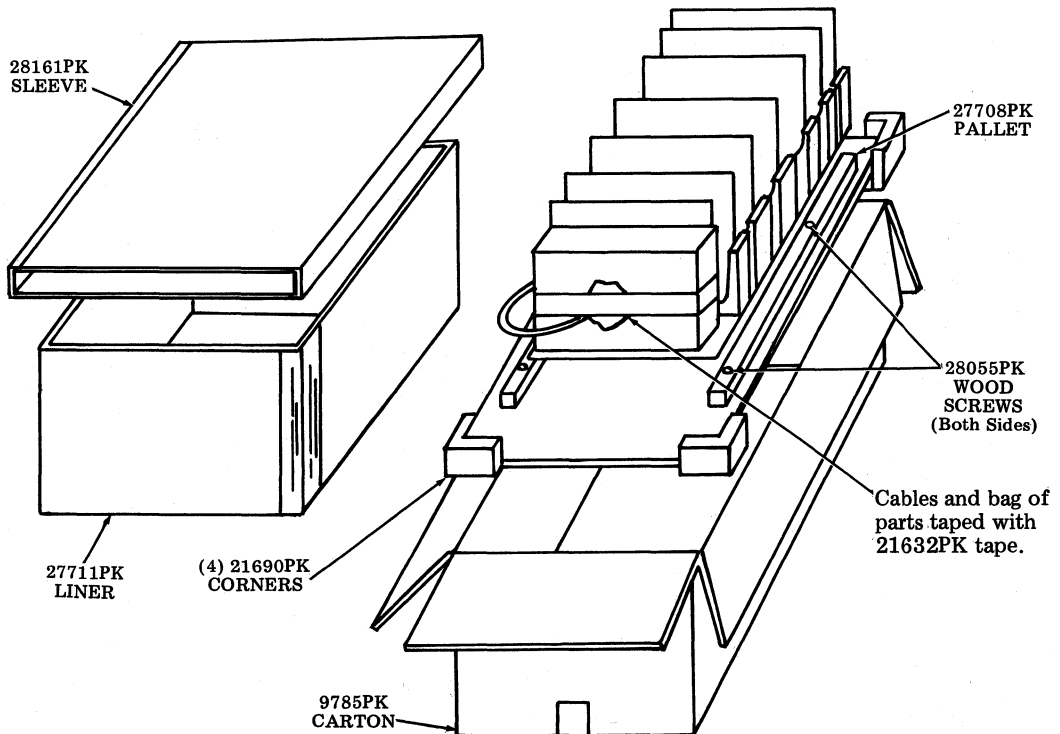

Fig. 44

Packing Procedure for 345605 Mounting Frame

- Step 1. Form 9292PK shipping container. Close and seal bottom flaps with glue or sealing tape.
- Step 2. Insert a 28158PK detail inside the 9292PK shipping container.
- Step 3. Position the mounting frame in the 9292PK shipping container.
- Step 4. Form a 28159PK detail and place it over the raised portion of the mounting frame.
- Step 5. Form a 28160PK detail and place it in the void area as shown in Fig. 45.
- Step 6. Close top flaps of carton and seal center seam with glue or sealing tape.

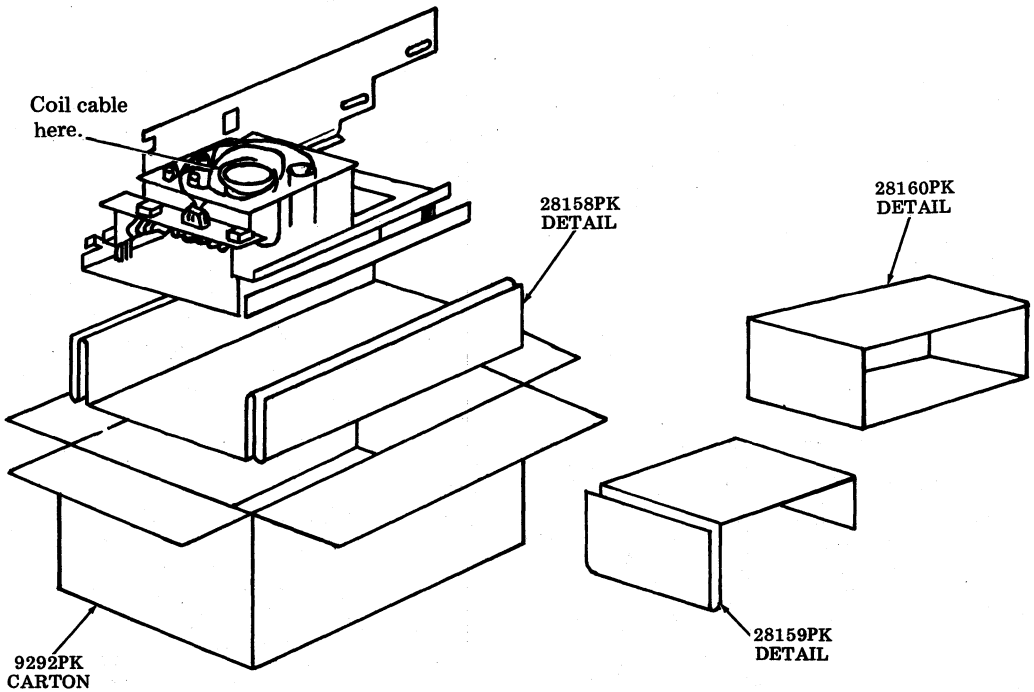

Fig. 45

EIA SWITCH

Packing Procedure for EIA Switch

- Step 1. Immobilize the three switches in the following manner: With the switches in their unoperated position, apply a piece of 21480PK tape approximately six inches long to the front bottom half of the buttons and tape to the cover.
- Step 2. Apply a piece of 21480PK tape approximately six inches long to the front upper half of the buttons and tape to the cover.
- Step 3. Wrap the switch assembly in triple thickness of 21298PK tissue paper.
- Step 4. Coil the 341986 cable assembly and wrap it in a double thickness of 21298PK tissue paper.
- Step 5. Tape the cable assembly to the top of the switch assembly with two wraps of 21480PK tape.
- Step 6. Wrap the switch and cable package in a four or five layer continuous length of 27951PK air cap packing. The switch front and rear surfaces should be equidistant from the 27951PK air cap front and rear edges, respectively.
- Step 7. Form 9030PK carton. Close bottom flaps and seal center seam with 21719PK tape. Extend tape three inches down carton sides.
- Step 8. Fold in open ends of the wrapped package of Step 6 so as to protect the switch front and rear surfaces. Insert wrapped package into 9030PK carton. The package should fit snugly in the carton. If loose, remove package and add additional wrap of 27951PK air cap packing.
- Step 9. Close top flaps of 9030PK carton and seal center seam with 21719PK tape as indicated in Step 7.

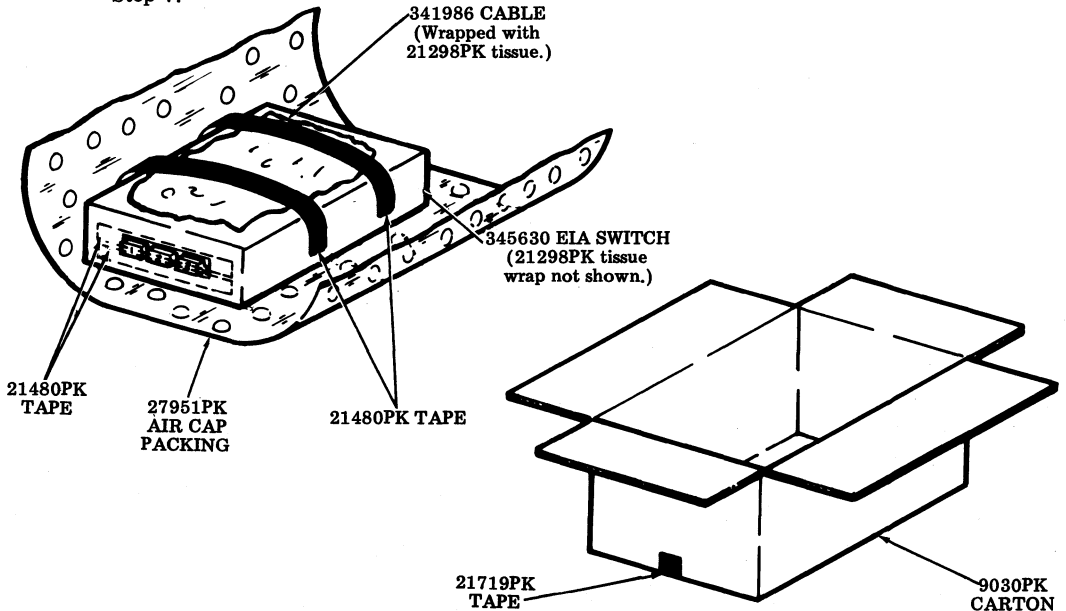

Fig. 46

KEYBOARD DISPLAY AMPLIFIER (KDA)

Packing Procedure for KDA

- Step 1. Place unit in a 23465PK plastic bag (not shown in illustration).
- Step 2. Form a 8889PK carton. Close and seal bottom flaps of carton with a strip of 21719PK tape.
- Step 3. Form a 28258PK detail and place in carton as shown in Fig. 47.
- Step 4. Place unit in carton between folds in detail.
- Step 5. Form a 28257PK detail and place in carton over and against sides of unit.
- Step 6. Close and seal top flaps of carton as outlined in Step 2.
- Step 7. Form a 9064PK carton as shown in Fig. 48. Close and seal bottom flaps as outlined in Step 2.
- Step 8. Place a 28153PK plastic corner in each of the four corners of the carton.
- Step 9. Place prepacked unit inside the plastic corners.
- Step 10. Place a 28153PK plastic corner on each of the four corners of the carton.
- Step 11. Close and seal top flaps of carton.

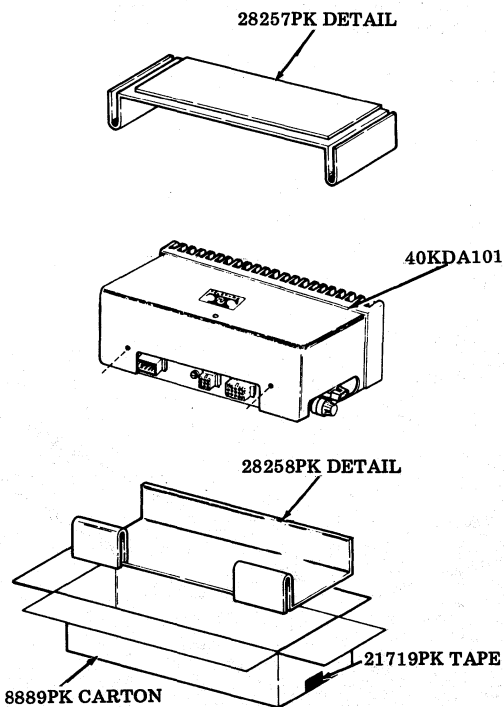

Fig. 47

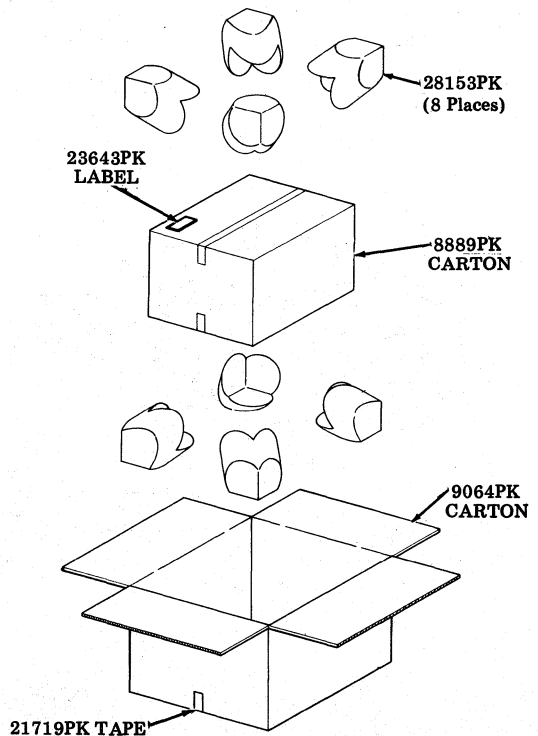

Fig. 48

40K00X OPERATOR CONSOLE**Packing Procedure for ROP Opcon**

- Step 1. Form an 8762PK carton. Close and seal bottom flaps with a strip of 21719PK tape applied to the center seam and extending three inches down the ends of the carton.
- Step 2. Place one 28327PK corrugated pad on top of the keytops. Tape securely to keyboard with two pieces of 21632PK tape (one piece across the length and one piece across the width of the pad). (See Fig. 39.)
- Step 3. Cut a seventy six inch long piece of 27952PK air cap and place on bench.
- Step 4. Place unit with open end down lengthwise on center of air cap approximately six inches from the end.
- Step 5. Wrap the unit lengthwise and tape end of air cap with a strip of 21480PK tape.
- Step 6. With manufacturers joint on the carton to the right side, place the unit into the carton with the keytops to the side of the carton. (See Fig. 49).
- Step 7. Close and seal top flaps of carton as indicated in Step 1.

Note: 27952PK air cap deleted for clarity.

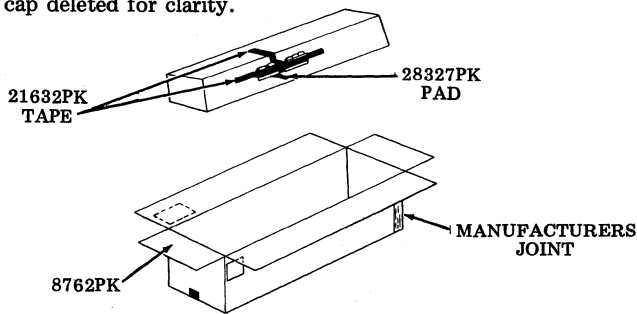

Fig. 49

40K100 OPERATOR CONSOLE**Packing Procedure for Opcon**

- Step 1. Place spare keytops in a 21307PK muslin bag and set aside.
- Step 2. Place a 28164PK Detail A base on work bench. Place muslin bag containing keytops in cavity provided.
- Step 3. Remove KD opcon cover; if late design, 2816PK packing details are used.
- Step 4. Place unit in a 23456PK plastic bag. Close open end of bag and secure with a strip of 21480PK tape.
- Step 5. Place a 28164PK Detail B cover over keyboard and place KD opcon cover in cavity provided in late design 28164PK Detail B.
- Step 6. Secure 28164PK Detail A base to Detail B cover with a band of 21632PK tape applied around each end of plastic details.
- Step 7. Form a 9526PK carton. Close bottom flaps and seal center seam with a strip of 21719PK tape. The tape should extend approximately three inches down ends of carton. (See Figs. 50 and 51.)
- Step 8. Place prepacked unit in carton. Close top flaps of carton and seal as outlined in Step 7.

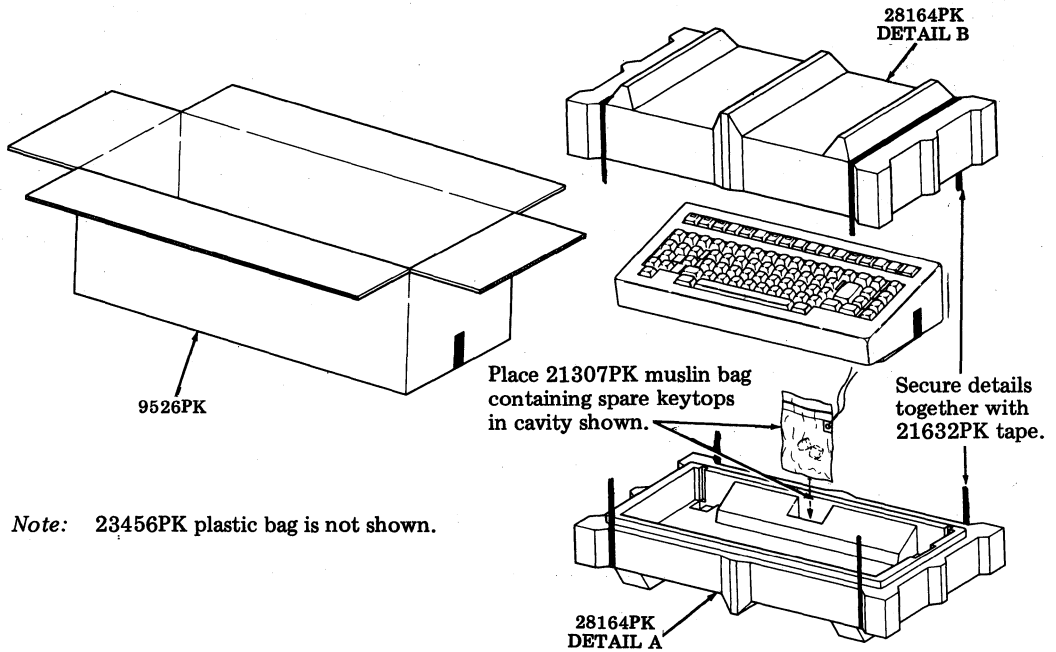

Fig. 50—Early Design Packing Detail

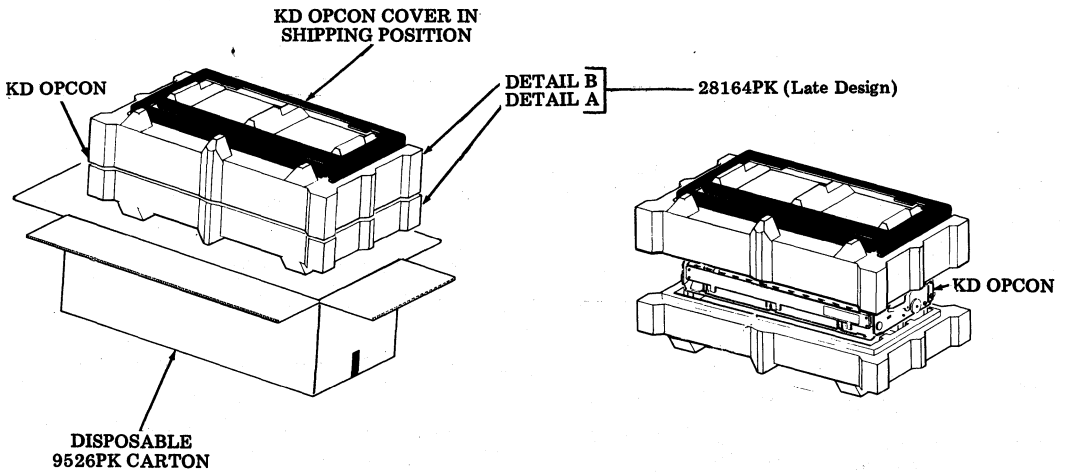

Fig. 51—Late Design Packing Detail

40K200 OPERATOR CONSOLE

Packing Procedure for Opcon

- Step 1. Place spare keytops in a 21307PK muslin bag and secure in cavity of 28335PK Detail B, as shown in Fig. 52.
- Step 2. Place a 28335PK Detail A base on work bench.
- Step 3. Remove opcon cover and secure in top cavity of 28335 Detail B.
- Step 4. Place unit in a 23457PK plastic bag. Plastic bag is deleted from illustration for clarity. Close open end of bag and secure with a strip of 21480PK tape.
- Step 5. Place a 28335PK Detail B cover over opcon as shown in Fig. 52.
- Step 6. Secure 28335PK Detail A base to Detail B cover with a band of 21632PK tape applied around each end of plastic details.
- Step 7. Form a 9403PK carton. Close bottom flaps and seal center seam with a strip of 21719PK tape. The tape should extend approximately three inches down ends of carton.
- Step 8. Place prepacked unit in carton. Close top flaps of carton and seal as outlined in Step 7.

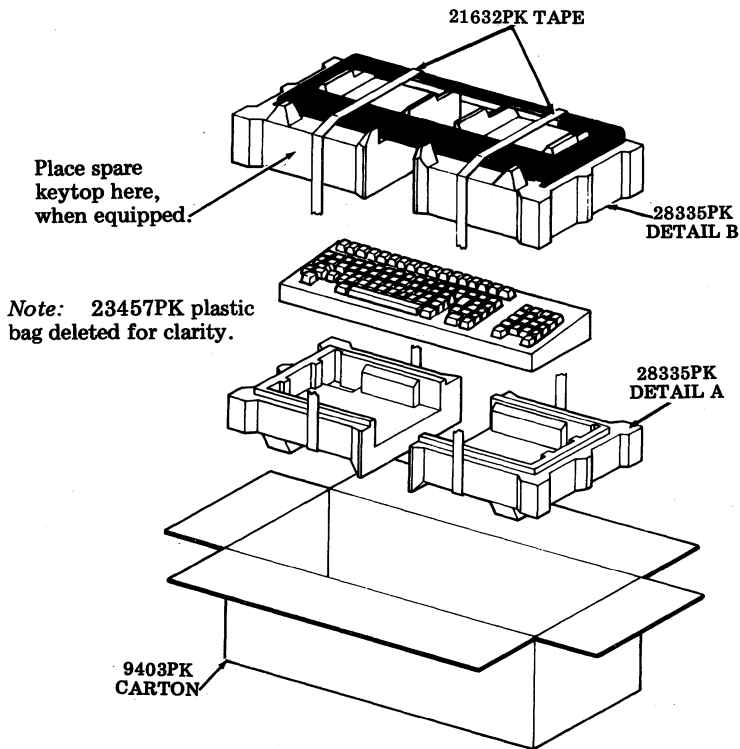

Fig. 52

40PSU101 POWER SUPPLY

Packing Procedure for 40PSU101 Power Supply

- Step 1. Form a 28210PK corrugated detail. Position detail in end of unit as illustrated in Fig. 43. The edge on short end of detail must butt against transformer, and the edge on long end of detail must butt against the inside of power supply cover. Secure detail in place with two strips of 21632PK tape as shown in Fig. 53.
- Step 2. Form a 9229PK carton. Close and seal bottom flaps with a strip of 21719PK tape. The tape should extend approximately three inches down ends of carton.
- Step 3. Form a 28211PK Detail A and place in carton as illustrated in Fig. 53. Center detail in carton.
- Step 4. Position a 28211PK Detail B in either end of carton as illustrated in Fig. 53.
- Step 5. Place unit in a 23456PK plastic bag. Position unit in carton as illustrated in Fig. 53.
- Step 6. Fold the 28211PK Detail A flap over top of unit. Close and seal top flaps of carton as outlined in Step 2.

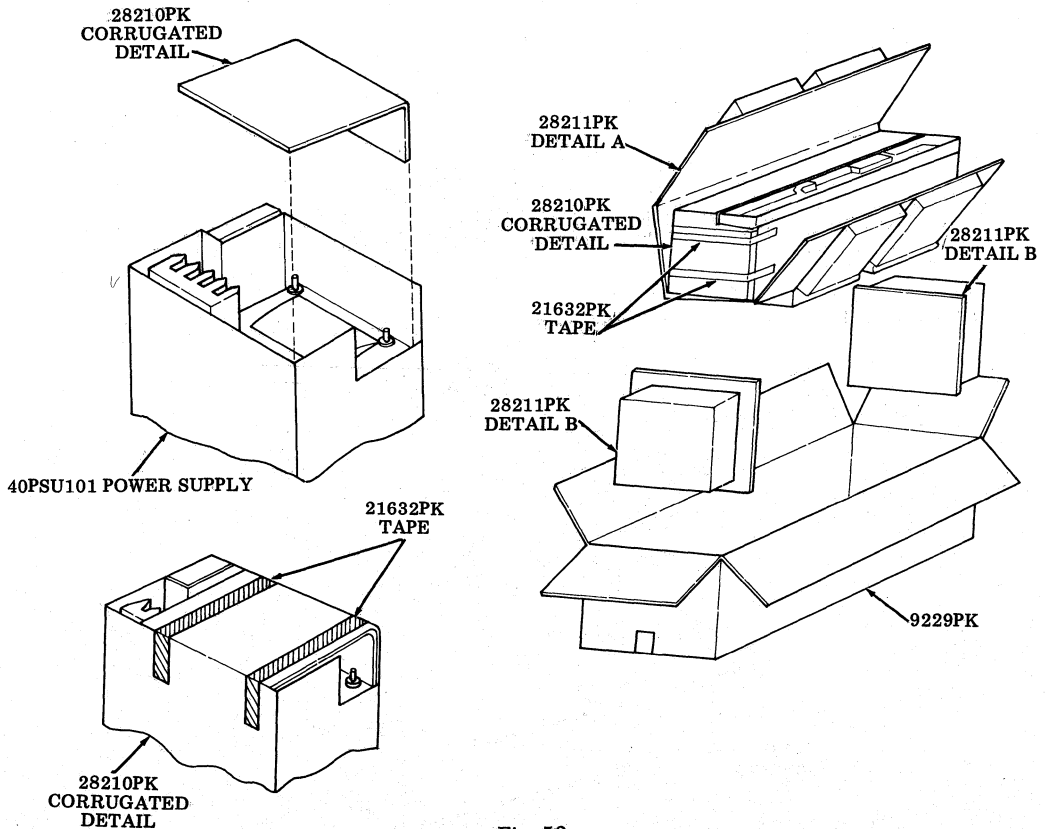

Fig. 53

40PSU102 POWER SUPPLY

Packing Procedure for 40PSU102 Power Supply

- Step 1. Assemble pallet No. 28212PK to bottom of power supply with one 71692RM screw, one 72295RM flat washer, and one 2669 lockwasher, as illustrated in Fig. 54.
- Step 2. Form a 9362PK corrugated detail. Close and seal bottom flaps with a strip of 21719PK tape. The tape should extend approximately three inches down ends of carton.
- Step 3. Place palletized unit in carton. Form a 28213PK detail and place in carton as illustrated in Fig. 54.
- Step 4. Close and seal top flaps of carton as outlined in Step 2.
- Step 5. Form a 9822PK shipping container. Form bottom flaps outward and place over inner container as illustrated in Fig. 55.
- Step 6. Position a 28153PK corner detail on each of the four corners of the inner container as illustrated in Fig. 55.

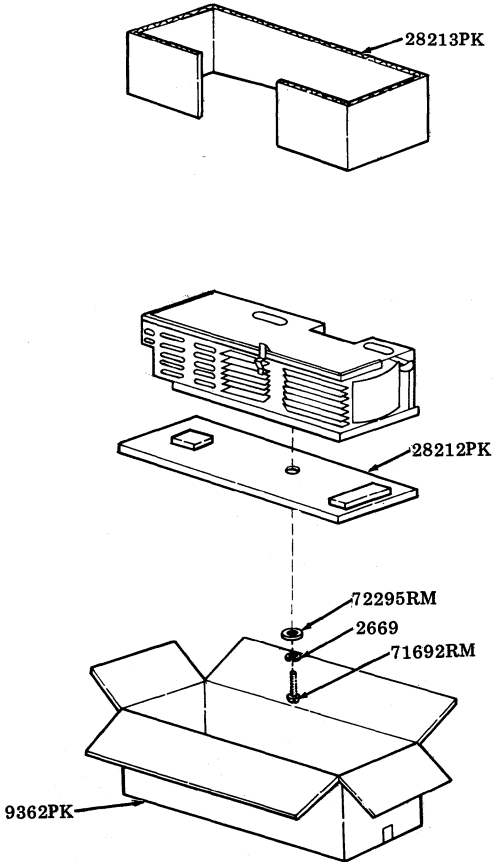

Fig. 54

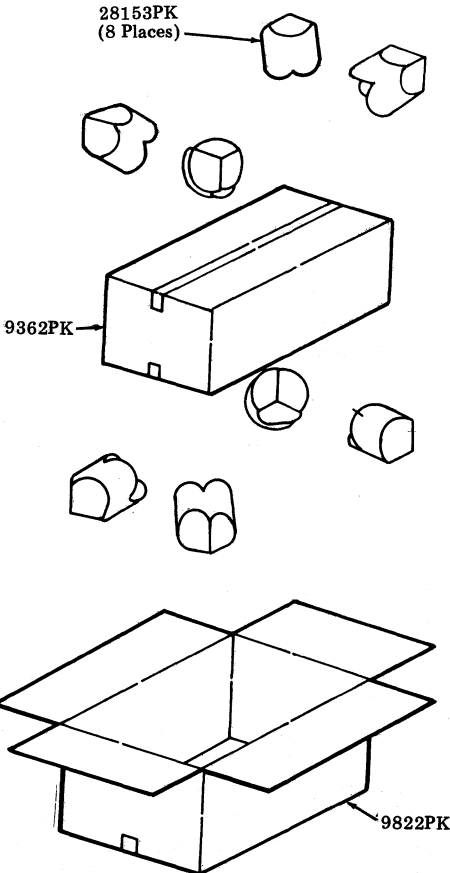

Fig. 55

40DL291 DISPLAY LOGIC

Packing Procedure for 40DL291 Display Logic

- Step 1. Form 9504PK carton. Close and seal bottom flaps with glue or 2 inch minimum width sealing tape.
- Step 2. Form detail 28141PK and position in carton as illustrated in Fig. 56.
- Step 3. Place unit in 23456PK plastic bag. Position unit in carton. Let cable extend outside of carton.
- Step 4. Form 28142PK detail and position in carton on top of unit as illustrated in Fig. 56. Position cable in void formed by detail.
- Step 5. Close top flaps of carton and seal as outlined in Step 1.
- Step 6. Form 10188PK shipping container. Form bottom flaps outward and place over inner container as illustrated in Fig. 56.
- Step 7. Position a 21690PK corner detail on each of the four corners of the inner container as illustrated in Fig. 57.
- Step 8. Close and seal top flaps as outlined in Step 1. Invert shipping container and contents.
- Step 9. Position a 21690PK corner detail on each of the four corners of the inner container as illustrated in Fig. 57.
- Step 10. Close and seal bottom flaps as outlined in Step 1. Invert shipping container and contents.

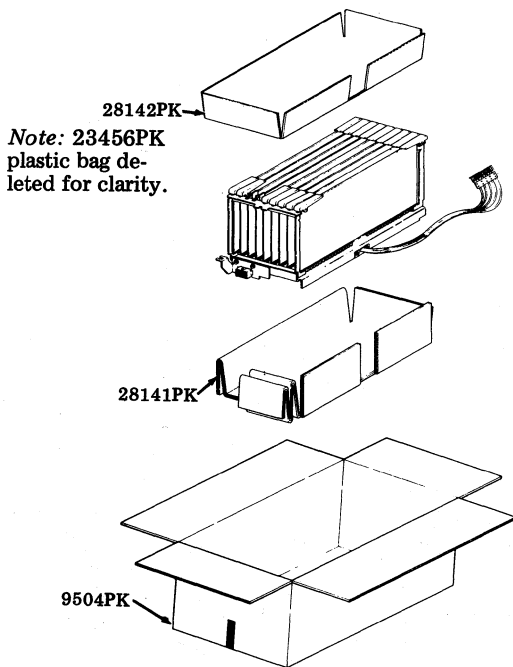

Fig. 56

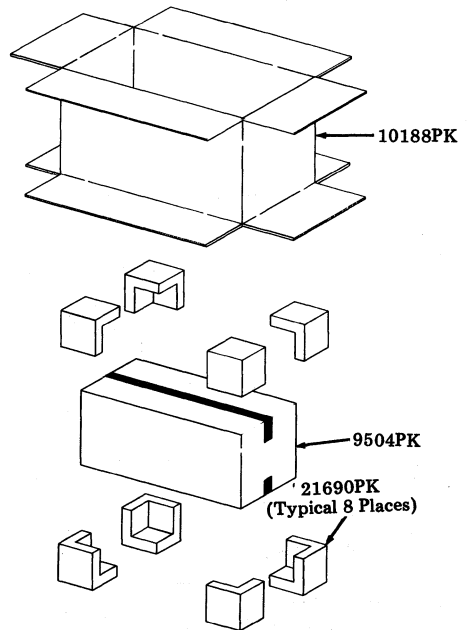

Fig. 57

40C101, 40C102, 40C201, 40C202, AND 40C204 CONTROLLERS

Packing Procedure for Controllers

- Step 1. Form a 9039PK carton. Fold bottom flaps closed and seal center seam with 21719PK tape. The tape should extend approximately three inches down the ends at the center seam.
- Step 2. Form a 28144PK detail. Position flap over top of connectors on end of controller and secure at ends with strips of 21632PK tape. See Fig. 58.

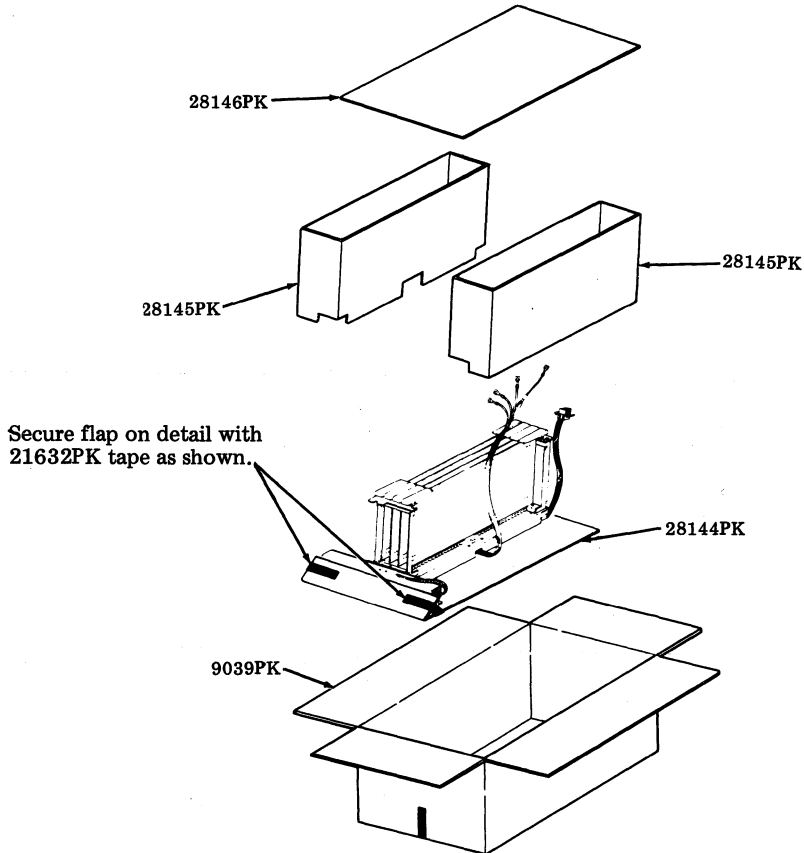

Fig. 58

- Step 3. Place unit and detail in carton.
- Step 4. Form two 28145PK details and position on either side of unit as illustrated in Fig. 58. The cable with connector must be positioned in the void formed by the 28145PK detail. See Fig. 58.
- Step 5. Place a 28146PK pad on top of the unit and details.
- Step 6. Close and seal top flaps of carton as indicated in Step 2.

Step 7. Form a 9640PK carton and with bottom of flaps outward place carton around prepacked unit.
See Fig. 59.

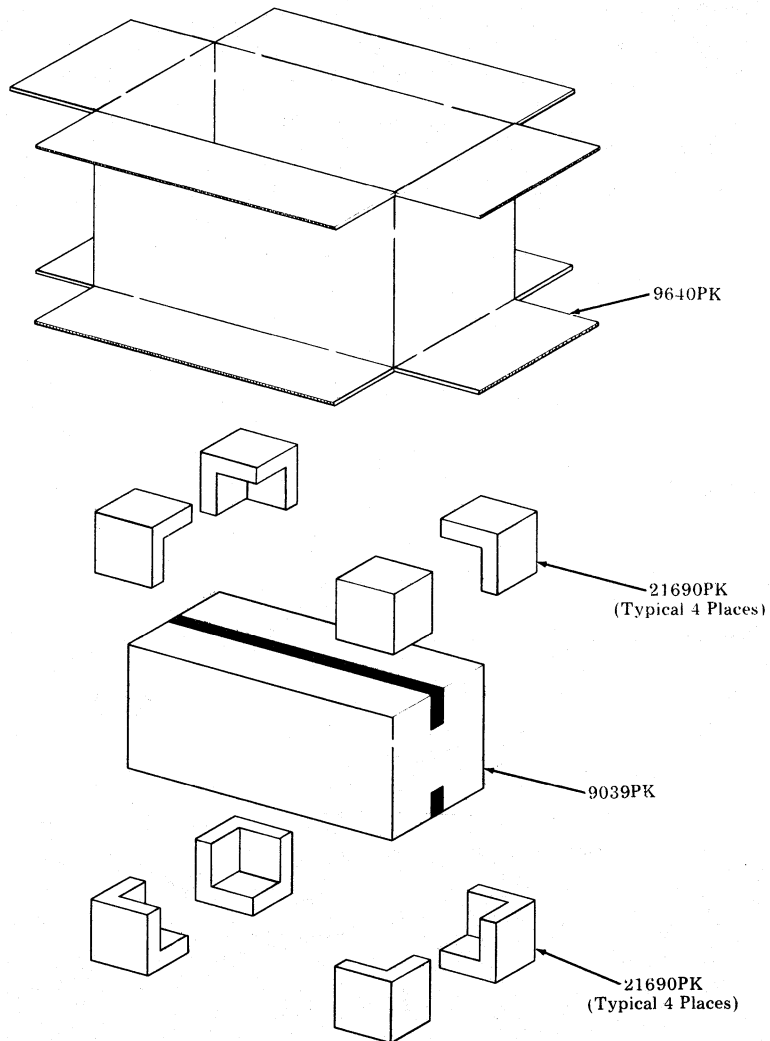

Fig. 59

- Step 8. Place a 21690PK plastic corner on each of the four corners of the inner carton. See Fig. 59.
- Step 9. Close and seal top flaps of carton as outlined in Step 2. Invert carton and contents.
- Step 10. Place a 21690PK plastic corner on each of the four corners of the inner carton. See Fig. 59.
- Step 11. Close and seal bottom flaps of carton as outlined in Step 2. Invert carton and contents.

40C103 CONTROLLER

Packing Procedure for Controller

- Step 1. Form a 8759PK carton. Close and seal top flaps with 21719PK tape. Apply the tape to the center seam and extend three inches down the ends of the carton.
- Step 2. Place two 28147PK details in carton as illustrated in Fig. 60.
- Step 3. Place unit in a 23465PK plastic bag.
- Step 4. Invert unit and place in carton so handles at top of unit fit in the cutout in the details. (See Fig. 60.)
- Step 5. Form a 28148PK detail and position around end of unit as illustrated in Fig. 60.
- Step 6. Form a second 28148PK detail and position around other end of unit as illustrated in Fig. 60.
- Step 7. Close and seal bottom flaps of carton as outlined in Step 1.

Note: 23465PK plastic bag deleted for clarity.

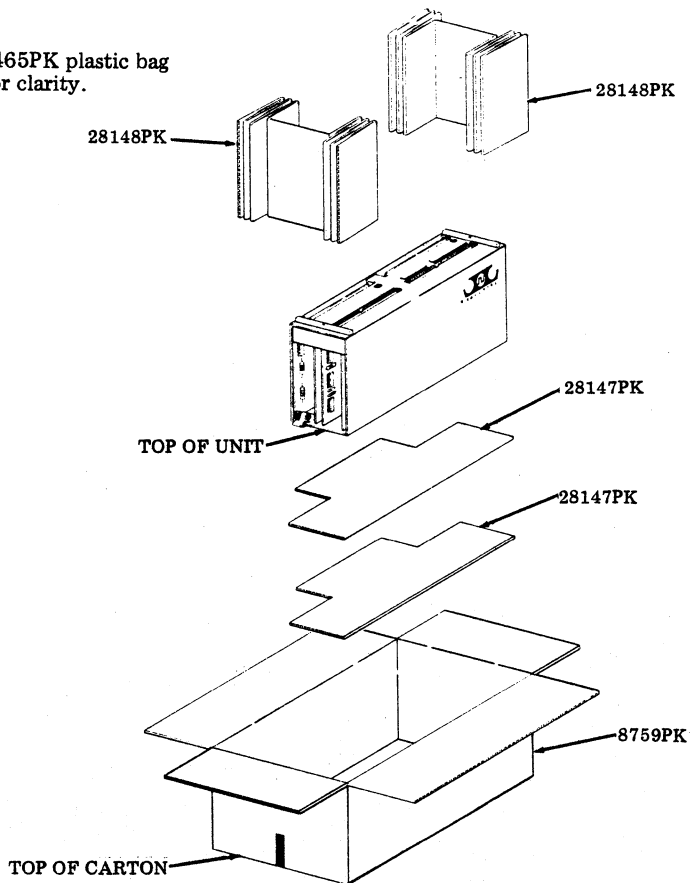

Fig. 60

SECTION 582-200-290

- Step 8. Form a 9136PK carton. Fold top flaps outward and place around packed unit. See Fig. 61.
- Step 9. Place a 21690PK plastic detail on each of the four corners of the inner carton. See Fig. 61.
- Step 10. Close and seal bottom of flaps of carton as outlined in Step 1. Invert carton.
- Step 11. Place a 21690PK plastic detail on each of the four corners of the inner carton. See Fig. 61.
- Step 12. Close top flaps of carton and seal as outlined in Step 1.

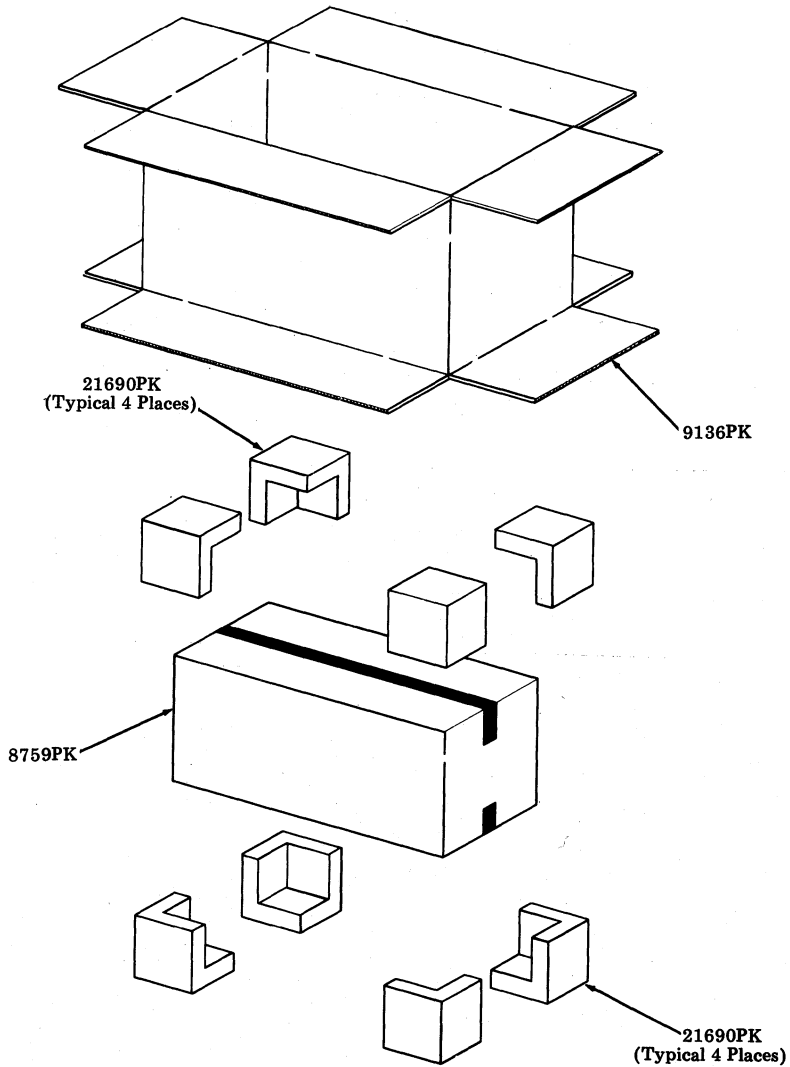

Fig. 61

40C400, 40C401, 40C402, AND 40C403 CONTROLLERS

Packing Procedure for Controller

- Step 1. Mount unit frame to a 28219PK plywood pallet with four 71676RM screws, four 2669 lock-washers and four 72295RM washers as illustrated in Fig. 62. The large hole in the pallet must be in line with the hole used to mount the PSU in the base.
- Step 2. Open cover of unit. Position a 28260PK pad on back surface of circuit cards. Close cover and secure in place. (See Fig. 62.)
- Step 3. Form a 9713PK carton. Close and seal bottom flaps with a strip of 21719PK tape. The tape should be applied to the center seam and extend approximately three inches down the ends of the carton.
- Step 4. Coil unit cable and secure with a 50136PK twist tie. Place palletized unit in carton. (See Fig. 62.)
- Step 5. Form a 28220PK liner and place in carton around unit. (See Fig. 62.)
- Step 6. Position cable at back of unit. Fill void space with 21298PK tissue to keep cable from shifting. (See Fig. 62.)
- Step 7. Close and seal top flaps of carton as outlined in Step 3.

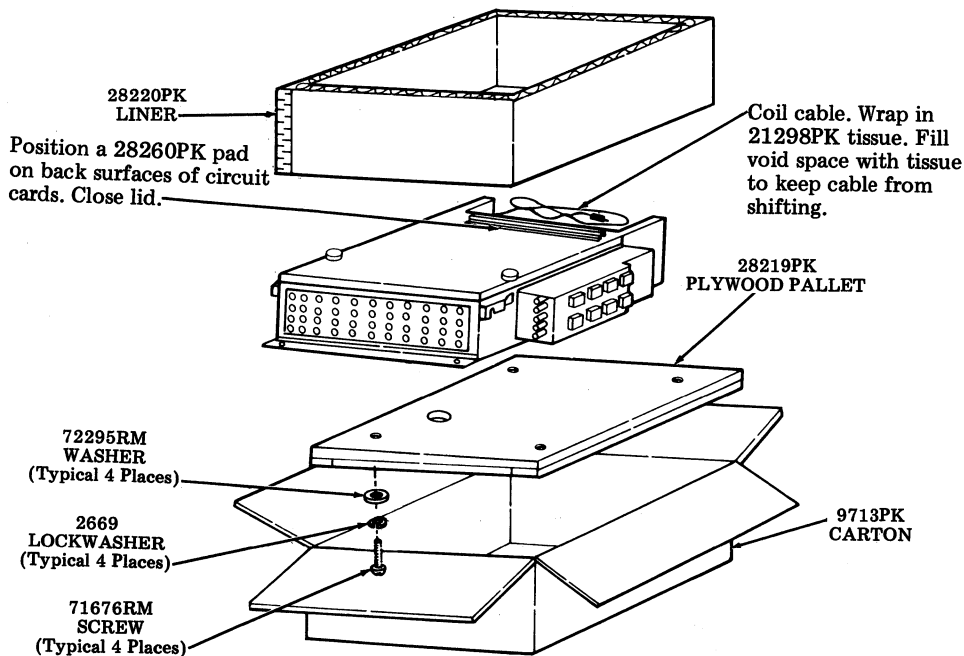

Fig. 62

- Step 8. Form a 10392PK carton. Fold bottom flaps outward and place around sealed carton. (See Fig. 63.)
- Step 9. Position a 27442PK plastic corner on each of the four corners of the inner carton.
- Step 10. Close top flaps and seal center seam with 21719PK tape as outlined in Step 3. Carefully invert carton and contents.
- Step 11. Position a 27442PK plastic corner on each of the four corners of the inner carton.
- Step 12. Close bottom flaps and seal center seam with 21719PK tape as outlined in Step 3. Carefully invert carton and contents.

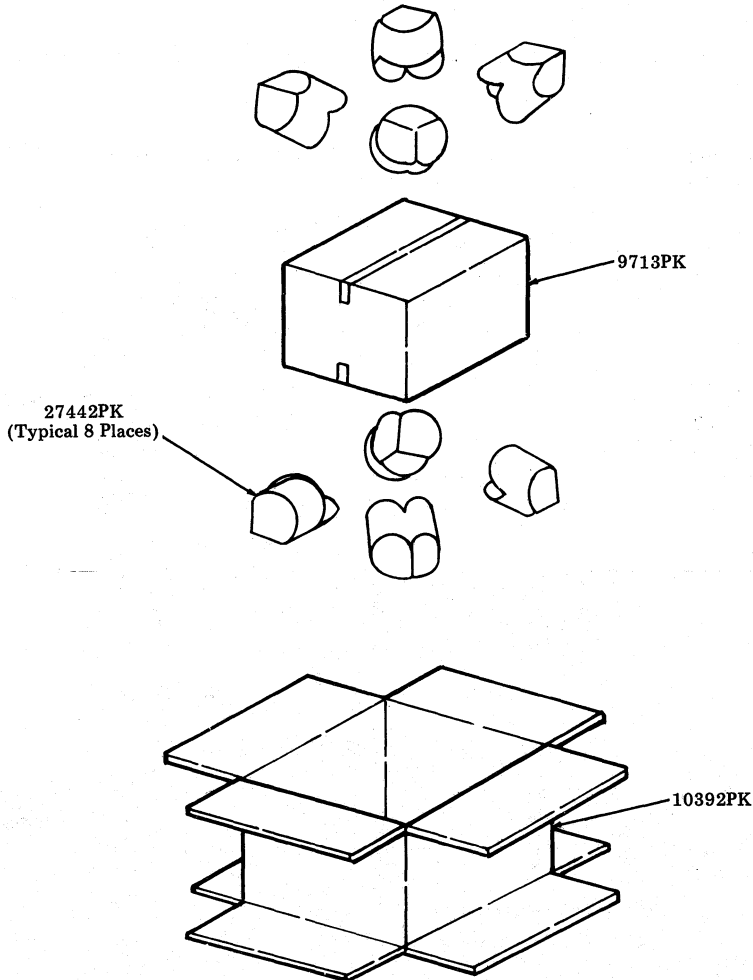

Fig. 63

40C430, 40C431, AND 40C432 CONTROLLERS

Packing Procedure for Controller

- Step 1. Position a 28235PK plywood detail against each end of controller. Securely tape details to unit with a band of 21632PK tape. See Fig. 64. Drape cables over top of unit.
- Step 2. Form a 10392PK carton. Close and seal bottom of flaps with a strip of 21719PK tape.
- Step 3. Position a 27442PK plastic corner in each of the four bottom corners of the carton. See Fig. 64.
- Step 4. Form a 9713PK carton. Close and seal bottom flaps with a strip of 21719PK tape.
- Step 5. Carefully place the 9713PK carton in the four plastic corners positioned in the 10392PK carton. (See Fig. 64.)
- Step 6. Place a 28236PK plywood detail in the 9713PK carton. (See Fig. 64.)
- Step 7. Grasp the front and rear of the controller and place in carton. (See Fig. 64.)
- Step 8. Wrap cables in 21298PK tissue paper. Fill void space with tissue.
- Step 9. Position a 28236PK plywood detail in the carton.
- Step 10. Close and seal top flaps of the 9713PK carton with a strip of 21719PK tape.
- Step 11. Position a 27442PK plastic corner on each of the four corners of the inner carton.
- Step 12. Close and seal top flaps of outer carton with a strip of 21719PK tape.

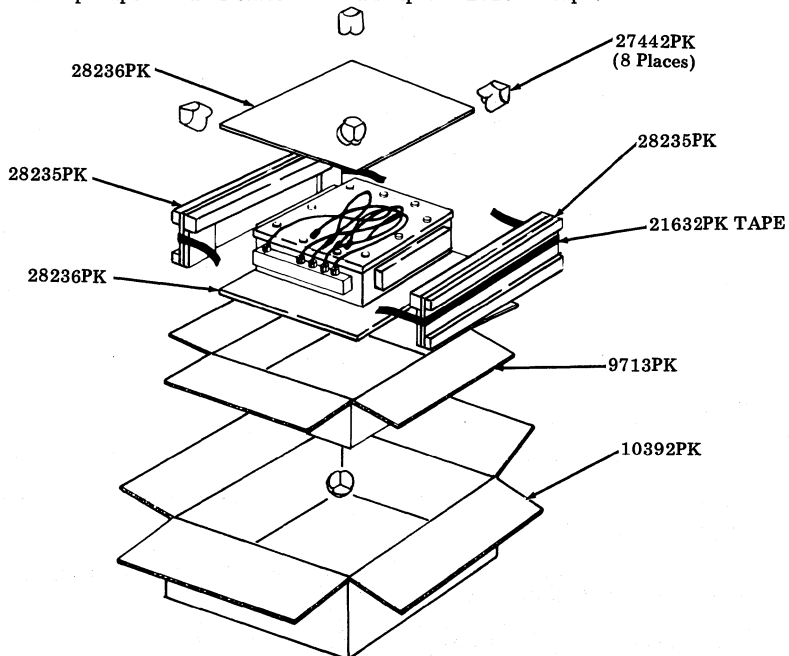
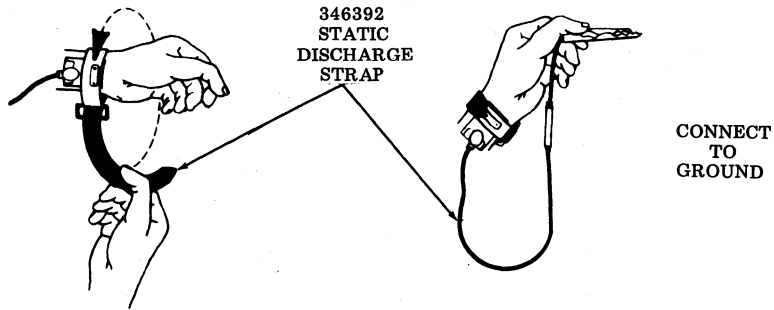

Fig. 64

40C303 CONTROLLER

Packing procedure for Controller

Caution: To avoid possible internal damage to circuitry, wear a 346392 static discharge strap connected to ground to allow static discharge before handling circuit cards for removal or replacement. Avoid touching circuit lands and card components as much as possible.



Note: 79157RM antistatic plastic bag deleted for clarity.

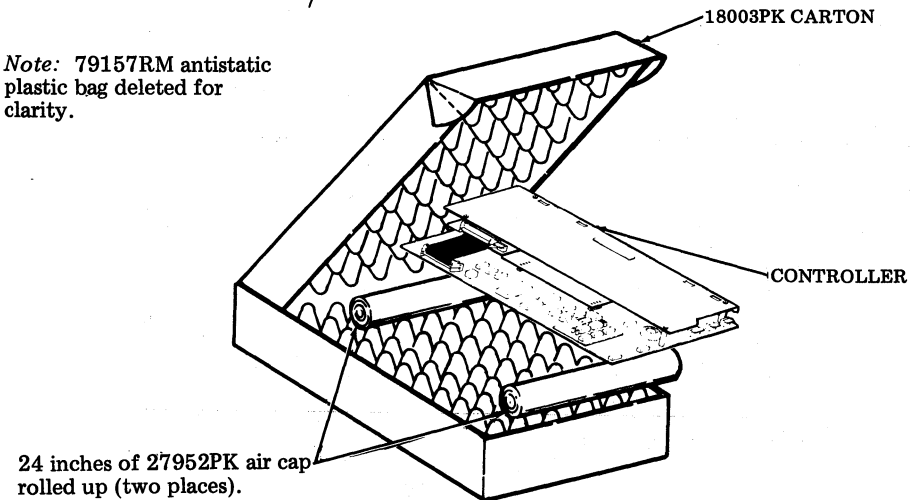

Fig. 65

- Step 1. Place controller in a 79157RM antistatic plastic bag.
- Step 2. Open one 18003PK carton with inserts.
- Step 3. Place the integrated controller into the carton on top of the foam, approximately centrally located. (See Fig. 65.)
- Step 4. Cut two 24 inch lengths of 27952PK air cap. Roll each length into a cylinder, position at either end of controller, and close carton.
- Step 5. Seal the bottom front flap with a strip of 21720PK tape.

40C304 AND 40C305 CONTROLLERS

Packing Procedure for Controller

- Step 1. Mount unit frame to a 28219PK plywood pallet with four 71676RM screws, four 2669 lock-washers and four 72295RM washers as illustrated in Fig. 55. The large hole in the pallet must be in line with the hole used to mount the PSU in the base. (See Fig. 66.)
- Step 2. After unit is completed, position a 28307PK plywood detail on top of the three circuit card grouping. Form and position a 28289PK corrugated detail over circuit cards and plywood detail as illustrated in Fig. 67.
- Step 3. Tightly secure the corrugated detail in place with four strips of 21632PK tape tightly applied over top of detail and extending down to bottom of unit at front and rear of unit. Pull tape firmly for good adhesion. (See Fig. 67.)
- Step 4. At power supply side of unit, remove front and rear screws holding unit to pallet. Loosen remaining two screws, two turns.
- Step 5. Separate unit and pallet on power supply side by wedging a 28308PK plywood detail between unit and pallet.
- Step 6. Tightly secure a 28308PK plywood detail to top of power supply with three double bands of 21632PK tape, applied over top of plywood detail and around front, bottom, and rear of unit. Tape should be in approximate position on plywood detail as shown in Fig. 67.
- Step 7. Remove 28308PK detail from between unit and pallet. Replace screw, washer, and lockwasher assemblies previously removed. Tighten all screws mounting unit to pallet.
- Step 8. Form a 9713PK carton. Close and seal bottom flaps with a strip of 21719PK tape. The tape should be applied to the center seam and extend approximately three inches down the ends of the carton.
- Step 9. Coil unit cable (when equipped) and secure to side of unit with 21632PK tape. Place palletized unit in carton. (See Fig. 66.)
- Step 10. Form a 28220PK liner and place in carton around unit. (See Fig. 66.)
Note: Special Operations Step 12, 13, and 14 are for 40C305 controller only.
- Step 11. Coil the following cables in a circle approximately 14 inches to 15 inches in diameter: two 406073, one 406074, and one 406075.
- Step 12. Tape each cable around the connectors with one strip of 21632PK tape.
- Step 13. Place cables between controller and 28220PK liner on side adjacent to fans. (See Fig. 66.)
- Step 14. Close and seal top flaps of carton as outlined in Step 8.

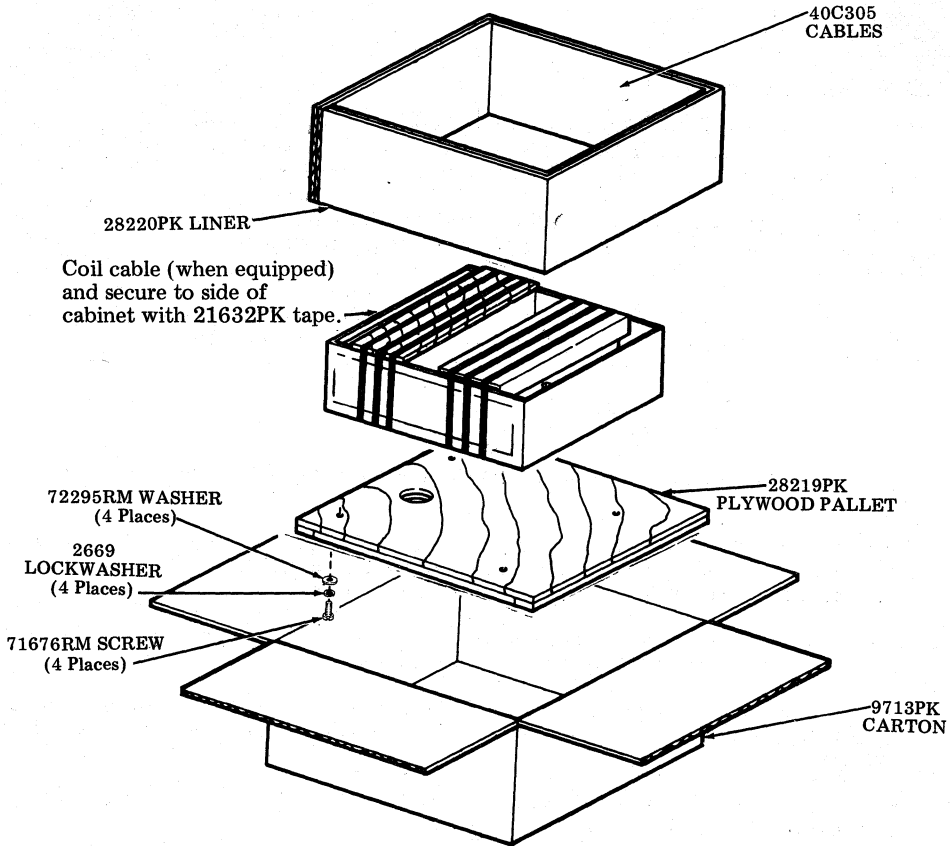

Fig. 66

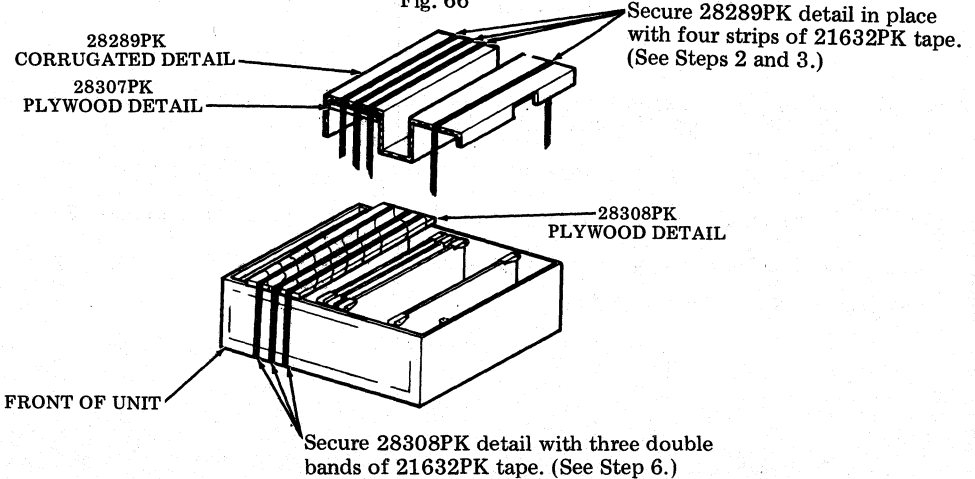

Fig. 67

- Step 15. Form a 10392PK carton. Fold bottom flaps outward and place around sealed carton. (See Fig. 68.)
- Step 16. Position a 27442PK plastic corner on each of the four corners of the inner carton. (See Fig. 68.)
- Step 17. Close top flaps and seal center seam with 21719PK tape as outlined in Step 8. Carefully invert carton and contents.
- Step 18. Position a 27442PK plastic corner on each of the four corners of the inner carton. (See Fig. 68.)
- Step 19. Close bottom flaps and seal center seam with 21719PK tape as outlined in Step 8. Carefully invert carton and contents.

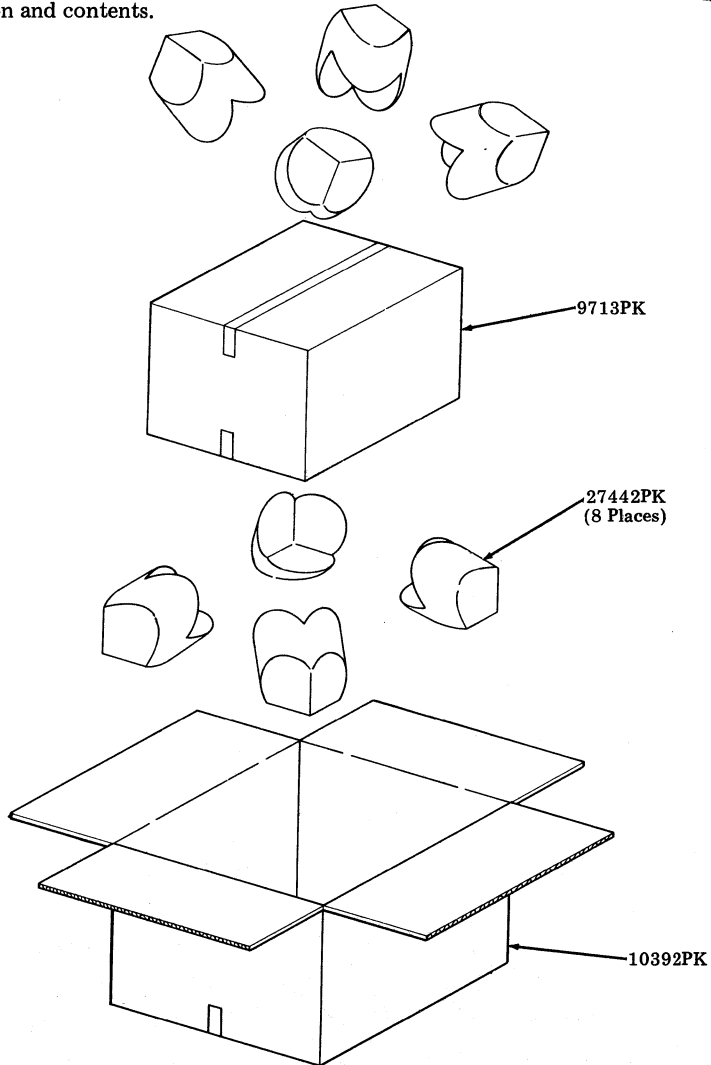

Fig. 68

40C434, 40C435, AND 40C436 CONTROLLERS

Packing Procedure for Controller

- Step 1. Position a 28293PK Detail A plywood detail against end of controller.
- Step 2. Position a 28293PK Detail B against opposite end of controller. See Fig. 69. Drape cables over top of unit.
- Step 3. Form a 10392PK carton. Close and seal bottom of flaps with a strip of 21719PK tape.
- Step 4. Position a 27442PK plastic corner in each of the four bottom corners of the carton. See Fig. 69.
- Step 5. Form a 9713PK carton. Close and seal bottom flaps with a strip of 21719PK tape.
- Step 6. Carefully place the 9713PK carton in the four plastic corners positioned in the 10392PK carton. (See Fig. 69.)
- Step 7. Place a 28236PK plywood detail in the 9713PK carton (See Fig. 69.)
- Step 8. Grasp the front and rear of the controller and place in carton. (See Fig. 69.)
- Step 9. Wrap cables in 21298PK tissue paper. Fill void space with tissue.
- Step 10. Position a 28236PK plywood detail in the carton.
- Step 11. Close and seal top flaps of the 9713PK carton with a strip of 21719PK tape.
- Step 12. Position a 27442PK plastic corner on each of the four corners of the inner carton.
- Step 13. Close and seal top flaps of outer carton with a strip of 21719PK tape.

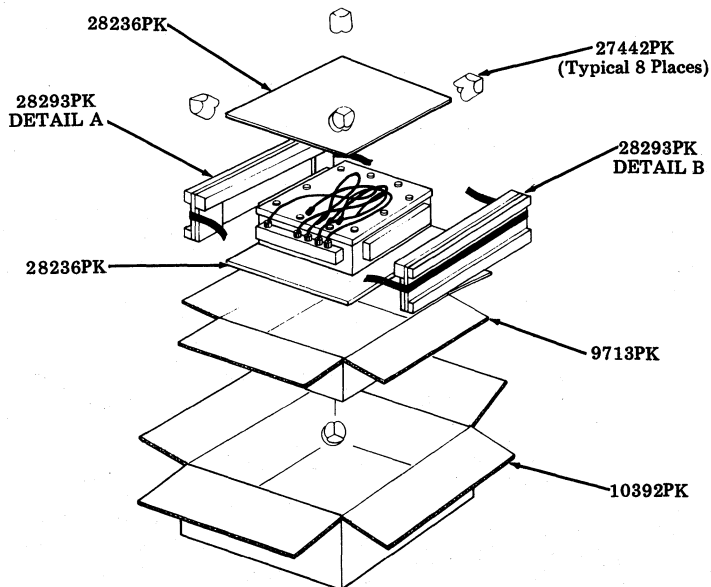

Fig. 69

401200 COPY HOLDER**Packing Procedure for Copy Holder**

- Step 1. Form 8814PK shipping container. Close and seal bottom flaps with glue or sealing tape.
- Step 2. Insert copy holder in container, close and seal top flaps with glue or sealing tape.

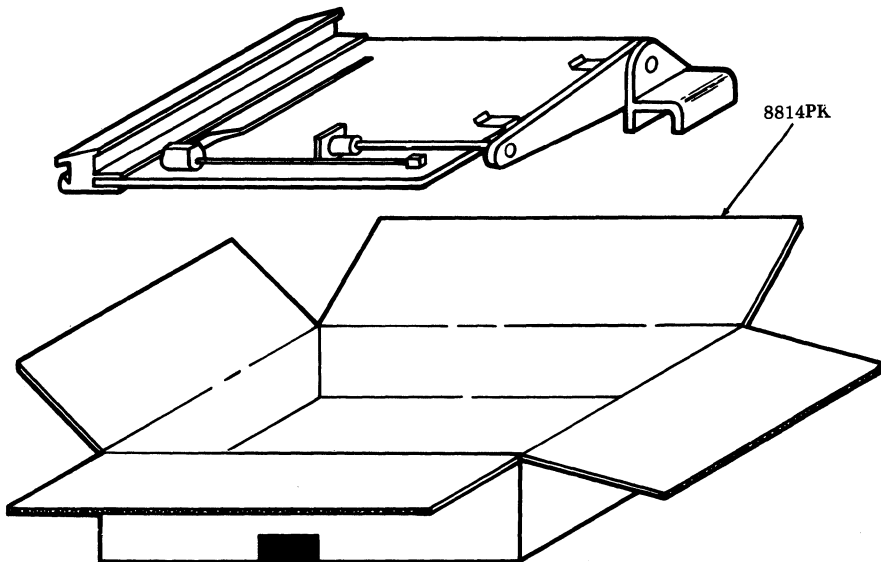

Fig. 70

40PWU101 AND 40PWU102 PAPER WINDERS

Packing Procedure for Paper Winders

- Step 1. Place loose parts in 652472RM cloth bag. Close bag and tie to hole in base plate as illustrated in Fig. 71.
- Step 2. Form 8563PK folder. Wrap base plate in tissue paper and place in folder.
- Step 3. Fold flaps of folder closed and seal with glue or sealing tape.
- Step 4. Form 9644PK shipping container. Close and seal bottom flaps with glue or sealing tape.
- Step 5. Place folder in container. Form 28193PK detail and place in container as illustrated in Fig. 71.
- Step 6. Remove paper spindle from unit. Place unit in a 23457PK plastic bag. Let cable extend outside of bag. Position unit in cutouts in detail as shown.
- Step 7. Form 28192PK detail. Position reel in detail. Secure flaps of detail in position (as shown in Fig. 71) with four strips of reinforced pressure sensitive tape.
- Step 8. Position prepacked reel in container as illustrated.
- Step 9. Coil line cord in void space formed by packing detail and the carton.
- Step 10. Secure the top of the shipping container (9644PK) with reinforced pressure sensitive tape.

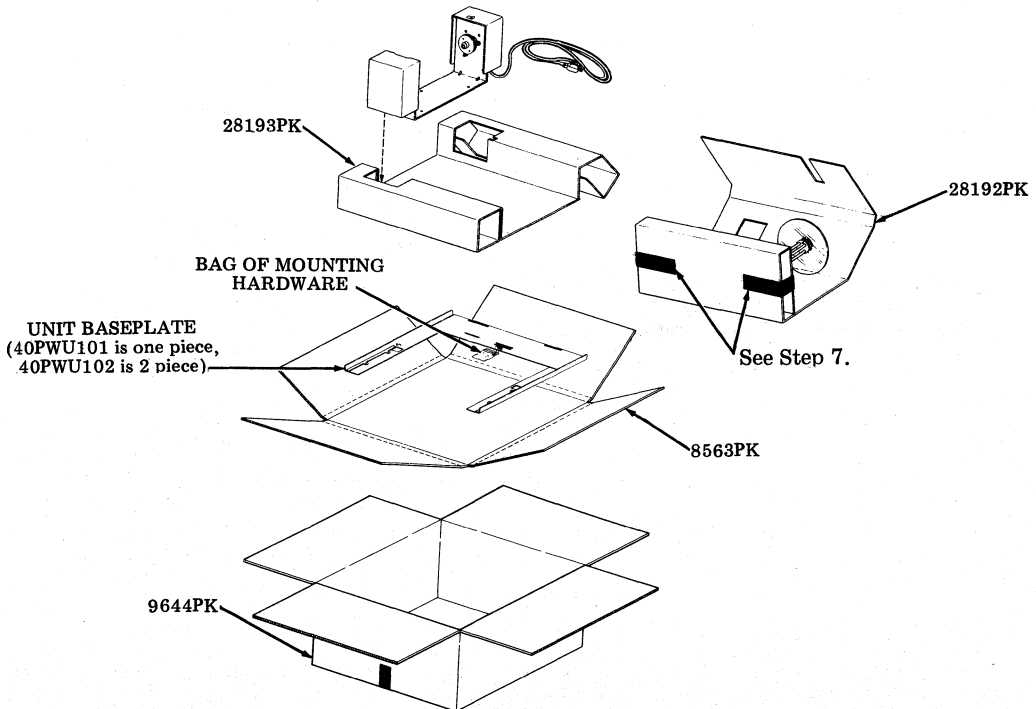

Fig. 71

4. WORKING STATION

4.01 The Working Station (WS) plan should be considered in returning DATASPEED 40 terminal equipment which is functional to Western Electric. Qualified apparatus submitted via the WS plan will result in reduced shop repair costs.

4.02 Criteria for qualification for Working Station (WS) processing are listed below. A Returned Material Tag (see Fig. 72) affixed to each station/terminal/component should be completed to designate (WS) plan if appropriate.

CRITERIA FOR QUALIFICATION

4.03 Apparatus should be completely operable such that it is functionally acceptable as is for reinstallation.

4.04 Apparatus should have had normal routine maintenance throughout service.

4.05 Apparatus returned to service center should meet appearance standards (required minor cleanup permissible).

4.06 Apparatus returned to service center should be undamaged.

4.07 Apparatus returned to service center should have a Returned Material Tag designating Working Station (WS) affixed to each component.

4.08 A material list (or service order or station/apparatus disconnect order) identifying the Working Station components shall be included with the returned equipment.

4.09 Apparatus which is not or cannot be broken down to defined M-List items without adding components or rework does not qualify as a candidate for Working Station processing. Examples of nonqualifying candidates for Working Station processing are as follows: Damaged apparatus, apparatus with missing components or parts, and apparatus modified such that extensive rework is necessary to restore it to conform to defined USOC M-List items as stocked at the Service Centers in repaired class "C" stock.

RETURNED MATERIAL TAG	
Data Sets And Terminals	
CIMS/LV TRACKING	
Ship To: _____	

Date: _____	
Tag # : _____	

Returned From: _____	
(Location)	
Technician's Name: _____	
Supervisor: _____	
Tel. # : _____	
Area: _____	
Quantity: _____	
Equipment Type: _____	
(Include Complete List #)	
<hr style="border: 1px solid black;"/>	
Reason For Return	
Good	<input type="checkbox"/> Service Order Disconnect <input type="checkbox"/> Surplus - Good <input type="checkbox"/> Job Cancelled <input type="checkbox"/> WS (Working Station)
Defective	<input type="checkbox"/> Defective On Arrival <input type="checkbox"/> Failed In Service <input type="checkbox"/> Pretest Failure <input type="checkbox"/> Surplus - Defective Or Unknown
Service Order # _____	
USSO # : _____	
Ckt # : _____	

Fig. 72—Returned Material Tag (Obtain Locally)

