

Xserve RAID

Xserve RAID and Xserve RAID (SFP)

Updated: 25 May 2004



Basics
Xserve RAID



Overview

Xserve RAID is a storage system that provides high-performance, scalable data access and management. It was designed to work with Xserve but is also compatible with desktop computers back to the Power Mac G4 (Digital Audio), as long as the computer has system software OS X (version 10.2.3 or later). A host adapter card must be installed in these computers to allow connection to the Xserve RAID system.



Xserve RAID offers dual independent RAID controllers, up to 14 hot-pluggable hard drives, and two hot-pluggable power supplies. Also featured are several connection options, including dual 2-gigabit fibre channel HSSDC2 or SFP ports, dual Ethernet ports (for managing the system remotely), and dual uninterruptible power supply (UPS) ports. The system is 5.25 inches (3U) high and can be mounted in a rack with four mounting posts.

Important: Due to the weight of the unit, two people are necessary for unpacking, lifting, mounting, or replacing the Xserve RAID system in a rack. Do not attempt to lift or move the system without help from another person.



Features

Key features of Xserve RAID include:

- 3U enclosure (5.25 inches high)
- rack optimized
- dual independent RAID controllers, each with a minimum of 128 megabytes (MB) of RAM cache
- up to 14 hot-swappable ATA-100 Apple Drive Modules, each with a minimum of 180 gigabyte (GB) capacity
- dual hot-swappable power supplies
- dual AC power connections
- dual hot-swappable cooling modules
- dual 2-gigabit (Gb) fibre channel HSSDC2 (original Xserve RAID) or SFP (Xserve RAID (SFP)) ports, supporting point-to-point and fabric (switched) connections
- dual Ethernet ports for remote management of the system
- dual ports for uninterruptible power supply (UPS) management
- Mac OS X compatibility (version 10.2 or later)
- Apple Fibre Channel PCI card (sold separately) with dual fibre channel connectors for host system
- optional dual battery backup for controller cache
- optional service parts kit
- optional drive modules

Rack Mount

Xserve RAID is designed to be mounted in a rack; however, rack mounting is optional. Because of the weight of the system, lifting or transferring Xserve RAID from a rack requires two people.

For information on mounting Xserve RAID in a rack, see the *Xserve RAID Setup Guide*.

Quick-Swap Modules

Several modules can be easily replaced in Xserve RAID without removing the system from its rack. Most of these modules are both redundant and hot-swappable. The following table is a quick reference to these modules:

Table 1: Quick-Swap Modules

Module	Hot-swappable?	Redundant?
ATA Drives	Yes	Depends on RAID config
Power Supplies	Yes	Yes
Cooling modules	Yes	Yes
Battery Modules	Yes	Yes
Controller Modules	No: System must be shut down first	No: Upper controller manages left seven drives; lower controller manages right seven drives

Identifier Light/Button

The identifier light on the Xserve RAID front panel turns on when internal sensors or a systems administrator detects a problem with the unit. The light can also be turned on by pressing the identifier button. This indicator will help you locate which Xserve RAID in a rack needs servicing. **Note:** A duplicate identifier light/button is on the unit's back panel.

Hot-Pluggable ATA Drives

Xserve includes fourteen hard drive bays at the front of the server, each of which supports a hot-pluggable ATA/100 drive module available only from Apple. You can replace or install hard drives while the server is running; you do not need to shut down or open the server first. A status light on the front of each drive indicates when it is safe to remove the drive without losing data. For more information, see "Hard Drive" in the Take Apart chapter.

RAID Controller Modules

Xserve RAID includes two controller modules, each with a minimum of 128 MB RAM. The top controller manages the seven drive modules on the system's left side (viewed from the front of the system); the bottom controller manages the seven drive modules on the right. Each controller module consists of the controller card, processor, and memory.

Power Supplies

Xserve RAID includes two redundant power supplies, each with an AC power connection. When one power supply is not operational, the other provides power for the entire system. You can replace or install a power supply while the system is running. If one power supply is removed from the system, it must be reinstalled or replaced with a working one as soon as possible to prevent the drive modules from overheating.

Cooling modules

Xserve RAID includes two redundant cooling modules. If one cooling module is not operational, the other provides cooling for the entire system. You can replace or install a cooling module while the system is running. If one cooling module is removed from the system, it must be reinstalled or replaced with a working one as soon as possible to avoid an over-temperature condition, which causes the system to shut down.

Backup Batteries

Xserve RAID may include up to two optional, redundant backup batteries, which protect data in the controllers' cache in the event of a power interruption. The Xserve RAID power supplies charge the battery modules when they are installed in the system. The batteries can be replaced or installed while the system is running.

To check a battery's charge when the module is out of the system, press the button on the underside of the module. All four green LEDs light when the battery module is fully charged. You can also use the monitoring or admin software to determine the battery's charge. See "Remote Monitoring" in the Troubleshooting chapter.

For proper operation of the battery, check the status lights on the front of the module. See "Status Lights" in the Troubleshooting chapter.

Host Adapter Card

The Apple Fibre Channel card is a 7-inch PCI card designed for use with Xserve RAID systems. The card is installed in a host system so that it can connect, using one or two fibre channel cables, to the controller cards in Xserve RAID. The host card provides fibre channel communication in both directions simultaneously at up to 2 gigabits per second (Gb/sec). If the card is used in an Xserve, it must be installed in the top PCI slot of the dual-slot riser card.

If host adapter cards are installed in each of two host systems, they can both connect to the same Xserve RAID: one host to the top controller card (for access to the left seven drives) and the other host to the bottom controller card (for access to the right seven drives).

Ports

The standard configuration of Xserve RAID includes the following ports on the back panel: two 2-gigabit fibre channel ports (HSSDC2 in the original Xserve RAID and SFP in Xserve RAID (SFP)) , two gigabit Ethernet ports, and two ports for uninterruptible power supply (UPS) management.

System administrators or service providers can connect a laptop computer or terminal to the Ethernet ports and then use command-line tools to change settings on the server.

Note: For a diagram of the ports location, see “Back Panel” in the Views chapter.

Diagnostics

Two types of diagnostics are available for Xserve RAID:

- status lights
- remote monitoring

For more information, see “Diagnostic Tools” in the Troubleshooting chapter.

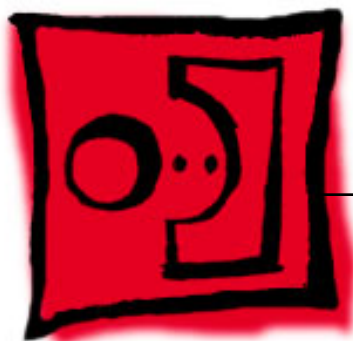

Take Apart
Xserve RAID



General Information

Tools

No tools are required for removing or installing the following parts: hard drive, power supply, cooling module, controller module, and backup battery. Other parts require only a Phillips screwdriver. If the system is locked, you will also need the Allen wrench key that came with the system.

Before Opening Xserve RAID

Unlocking Xserve RAID

If the system is in the locked position (the yellow security LED on the front panel is on), use the Allen key that came with the system to unlock it.

Shutting Down

You must shut down the system before replacing or installing all parts except the hard drives, power supplies, cooling modules, and backup batteries. Before shutting down, be sure to alert users that the system will be unavailable for a period of time.

Warning: After shutting down the system, you must wait a few minutes before servicing it to allow internal components to cool.

Electrostatic Discharge (ESD) Precautions

Follow these steps to avoid damage from ESD before working inside Xserve RAID.

1. Shut down the system.
2. Unplug all external cables except the power cords.
3. Touch the Xserve RAID metal case to discharge static electricity.
4. Unplug the power cords.
5. With the help of another person, remove the system from the rack, and place it on a flat surface, preferably covered by an ESD mat.
6. Put on an ESD wrist strap.
7. To avoid static electricity building back up in your body, do not walk around the room until after you have finished working and closed the system.



Hard Drive Module

Xserve RAID includes fourteen hard drive bays at the front of the system. Drives come as modules attached to carriers; they are removed from or installed in the system as a unit.

Note: Blank drive carriers, which may fill some of the hard drive bays, follow the same take-apart procedure as hard drives. If you are replacing a blank carrier with a drive module, instruct the system's administrator to keep the blank for possible future use. Blank carriers must be installed in all empty bays to maintain proper airflow through the system.

Tools

No tools are required for this procedure.

Preliminary Steps

Before you begin, make sure the drives are in the unlocked position. No other preliminary steps are required. You can replace or install hard drives while Xserve RAID is running; you do not need to shut down or open the unit first.

Note: There are two LED indicators on the front of each drive.

- The right LED shows drive status: a green light indicates the drive is good; a yellow or red light indicates the drive should be replaced or removed and reinserted.
- The left LED shows drive activity: when the light is blinking, the system is reading from or writing to the drive. To avoid losing data, never remove a drive when the lower LED is blinking.

WARNING: Drives must be in the unlocked position before you attempt to remove a drive. If the drives are locked, pulling on the drive to remove it could damage the drive handle.

Part Location



Procedure

1. Make sure the drive being replaced is not in use by any application and that removing it will not disrupt the RAID scheme in use.
2. Press the handle on the front of the drive module so that the handle pops out.



3. Wait for the right LED on the drive to go out. Then grasp the drive handle, and pull the drive module out of the system.

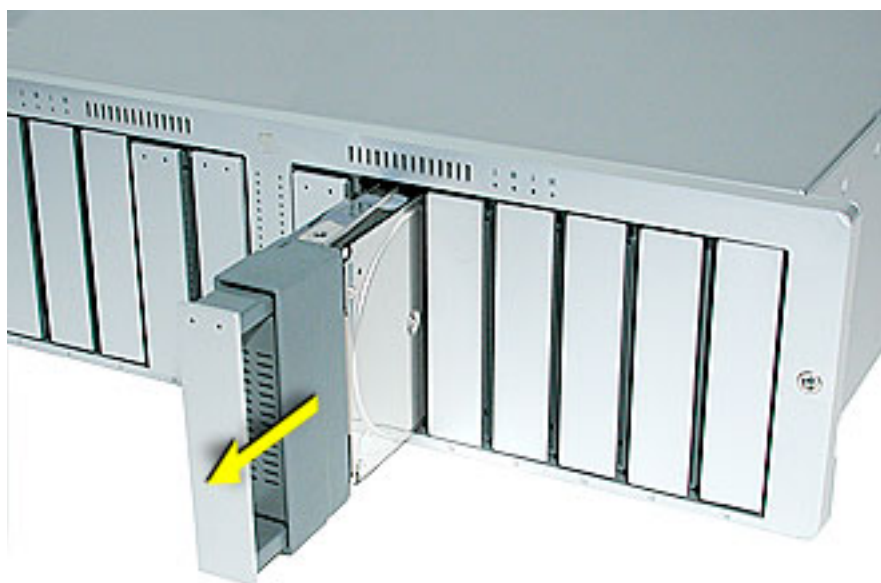

Important: To maintain proper airflow, do not leave a drive bay empty. If you permanently remove a drive, replace it with a blank drive module.



Power Supply

Xserve RAID includes two redundant power supplies. When one power supply is not operational, the other provides power for the entire system.

Tools

No tools are required for this procedure.

Preliminary Steps

No preliminary steps are required. You can replace or install a power supply while the system is running; you do not need to shut down or open Xserve RAID first.

Part Location



Procedure

1. For the power supply you want to replace, unplug the power cord from the power source.
2. Lift the clip that holds the power cord in place and remove the cord from the back of the power supply.
3. Press in the small latch on the power supply handle, and pull down to unlock it. Then holding the handle, pull the power supply straight out the back of the system.

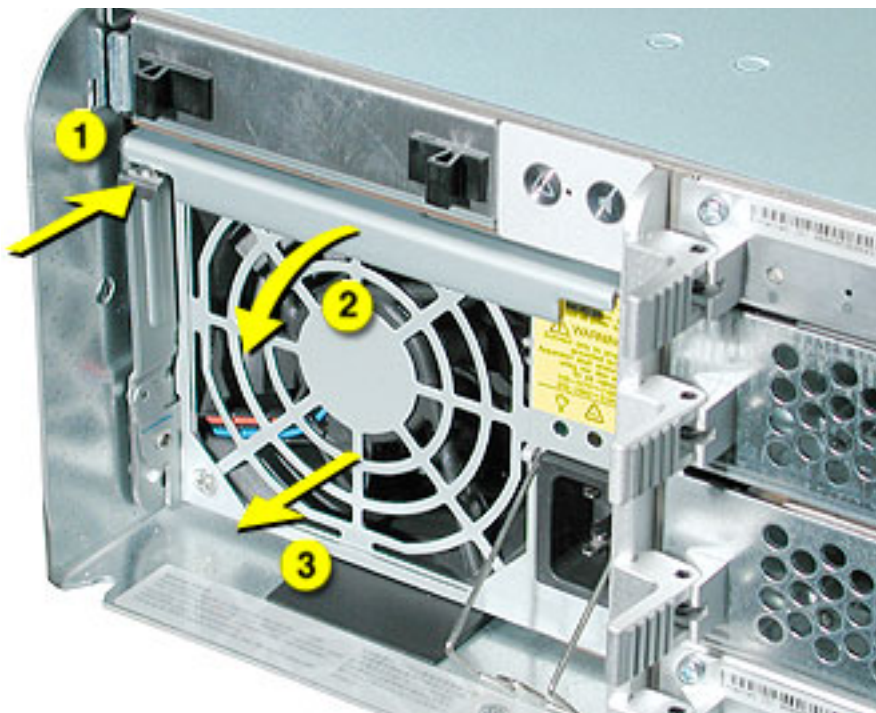

Warning: Do not reach inside the system when removing a power supply or when the power supply is out of the system.

Important: When you remove a power supply from the system, be sure to replace it with a working power supply as soon as possible to prevent the system from overheating.



Cooling module

Xserve RAID includes two redundant cooling modules. If one cooling module is not operational, the other provides cooling for the entire system.

Tools

No tools are required for this procedure.

Preliminary Steps

No preliminary steps are required. You can replace or install a cooling module while the system is running; you do not need to shut down or open Xserve RAID first.

Part Location



Procedure

1. Press apart the two latches on the back of the cooling module.
2. Holding the cooling module by the latches, pull it straight out the back of the Xserve RAID enclosure.



Important: When you remove a cooling module from the system, be sure to replace it with a working cooling module as soon as possible to prevent the system from overheating.



Controller Module

Xserve RAID includes two controller modules. The top controller manages the seven drive modules on the system's left side (viewed from the front of the system); the bottom controller manages the seven drive modules on the right.

Tools

No tools are required for this procedure.

Preliminary Steps

You must shut down the system, using the admin or monitoring software, before removing or installing a controller module.

Part Location



Procedure

1. Press apart the two latches on the back of the controller module.
2. Holding the controller module by the latches, pull it straight back out of the enclosure.





Battery Module

Xserve RAID may include up to two optional, redundant backup battery modules, which protect data in the controllers' cache in the event of a power interruption.

The battery module consists of a battery cell, battery recharger board, battery light pipe, and battery cable. This procedure explains how to remove the battery module from the enclosure.

Tools

No tools are required for this procedure.

Preliminary Steps

No preliminary steps are required. You can replace or install a battery module while the system is running; you do not need to shut down or open Xserve RAID first.

Part Location



Procedure

1. Squeeze together the two latches on the back of the battery module, and holding it by the handle, pull it straight back.
2. Remove the battery module from the Xserve RAID enclosure.



Note: When first installed, a new battery module will take several hours to charge completely. The system must be turned on to charge the battery.

Important: To maintain proper airflow, do not leave a battery bay empty. If you permanently remove a battery module, replace it with a blank battery cover, inserted as illustrated.





Removing Xserve RAID from the Rack

You must remove Xserve RAID from its rack to access all parts except the hard drive, power supply, cooling module, controller module, processor, memory, and backup battery.

Important: Due to the weight of the system, do not attempt to lift or move the system without help from another person.

Tools

The only tool required for this procedure is a Phillips screwdriver.

Preliminary Steps

See “Before Opening Xserve RAID” at the beginning of this chapter.

Procedure

1. Remove the two screws that secure the system to the front rail of the rack.

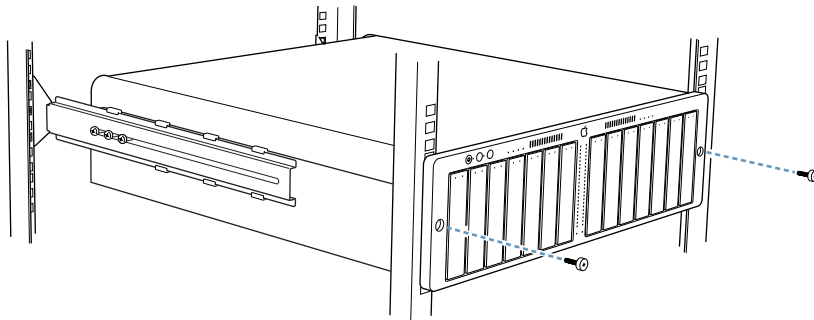

2. With one person supporting each side of the unit, slide the system out of the rack and place it on a sturdy, flat surface covered by an ESD mat.

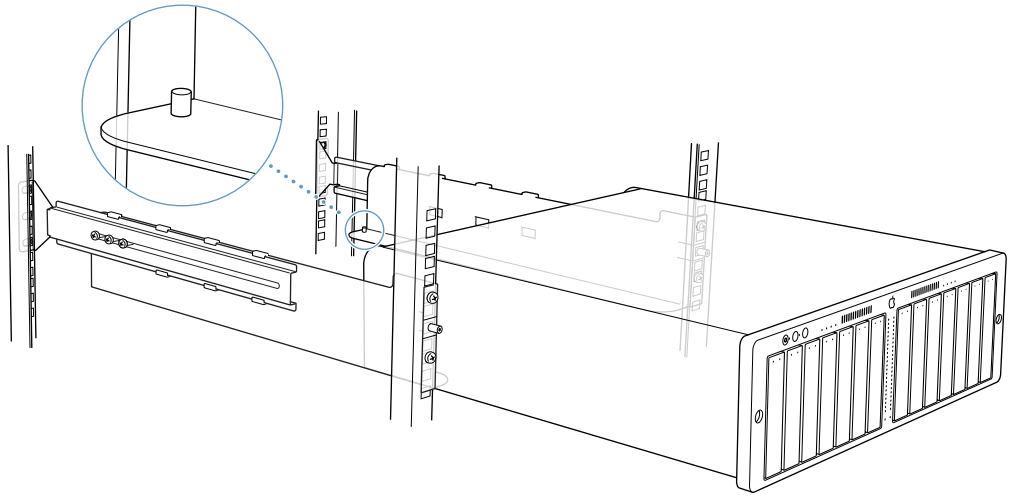

Replacement Note: When reinstalling the system, be sure to slide it all the way into the rack until it engages the small posts at the rear of the L-brackets.



Top Cover

You must remove the top cover to access all parts except the hard drive, power supply, cooling module, controller module, processor, memory, and backup battery.

Tools

The only tool required for this procedure is a Phillips screwdriver.

Preliminary Steps

Before you begin, remove the system from the rack and place it on a sturdy, flat surface and ESD mat.

Part Location



Procedure

1. Remove the eight mounting screws on each side of the top cover.



2. Slide the top cover a short distance toward the back of the unit.
3. Lift the top cover off the enclosure.



Locking Switch

Tools

The only tool required for this procedure is a Phillips screwdriver.

Preliminary Steps

Before you begin, remove the system from the rack and place it on a sturdy, flat surface and ESD mat. Then remove the top cover.

Part Location

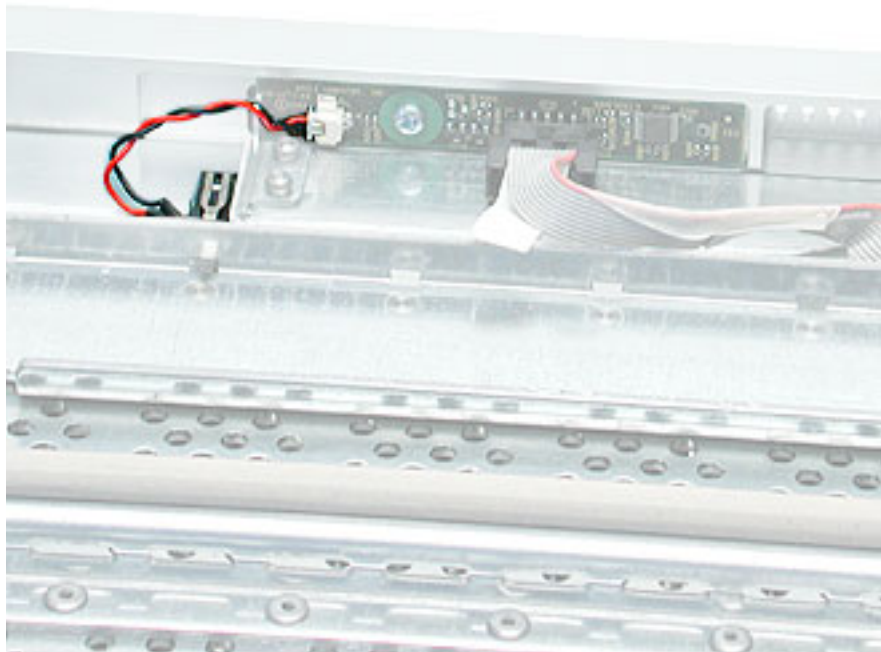

Procedure

1. Disconnect the locking switch cable from the right front panel board.
2. Remove the two screws that mount the locking switch to the chassis.
3. Remove the locking switch from the bottom housing.

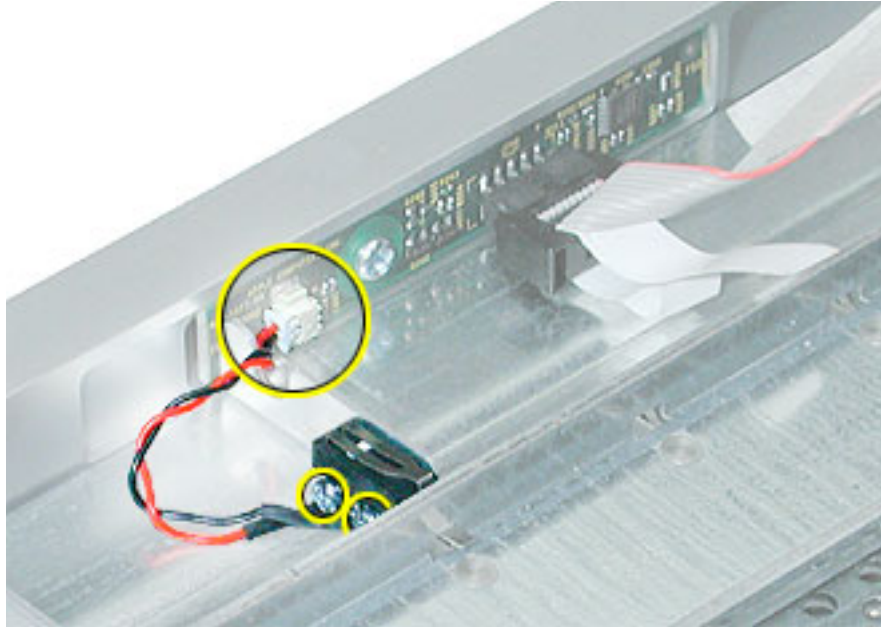



Front Bezel

Tools

The only tool required for this procedure is a Phillips screwdriver.

Preliminary Steps

Before you begin, remove the system from the rack and place it on a sturdy, flat surface and ESD mat. Then remove the top cover.

Part Location



Procedure

1. Disconnect the locking switch cable from the right front panel board.
2. Disconnect the front panel board cable from the left and right front panel boards.
3. Remove the four screws securing the bezel to the bottom housing.

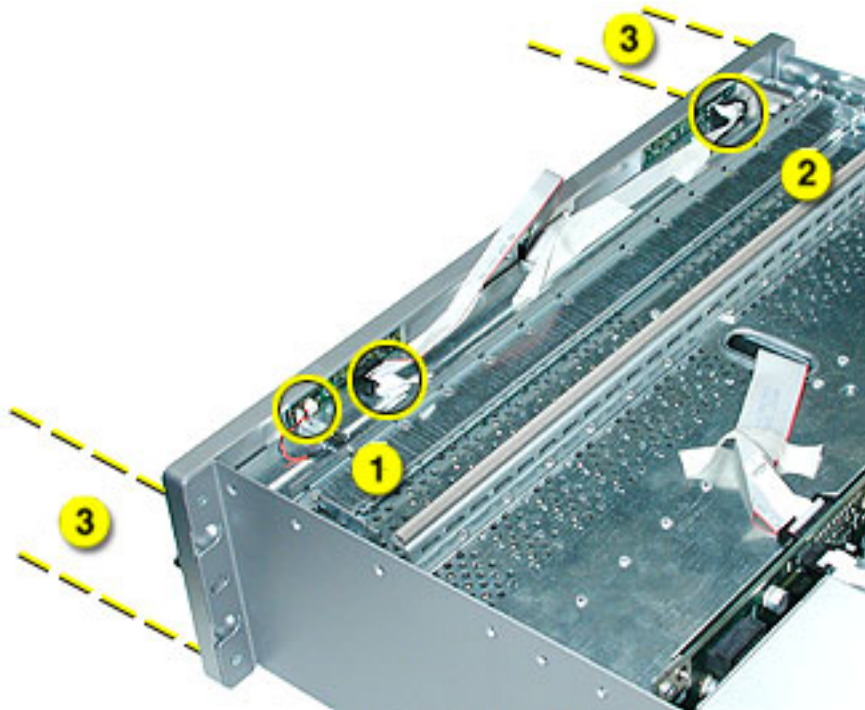

4. Carefully pull the bezel a short distance straight back off the bottom housing, making sure the bezel clears the barrel of the locking mechanism.
5. Disconnect the cable from the center front panel board.
6. Remove the bezel from the housing.

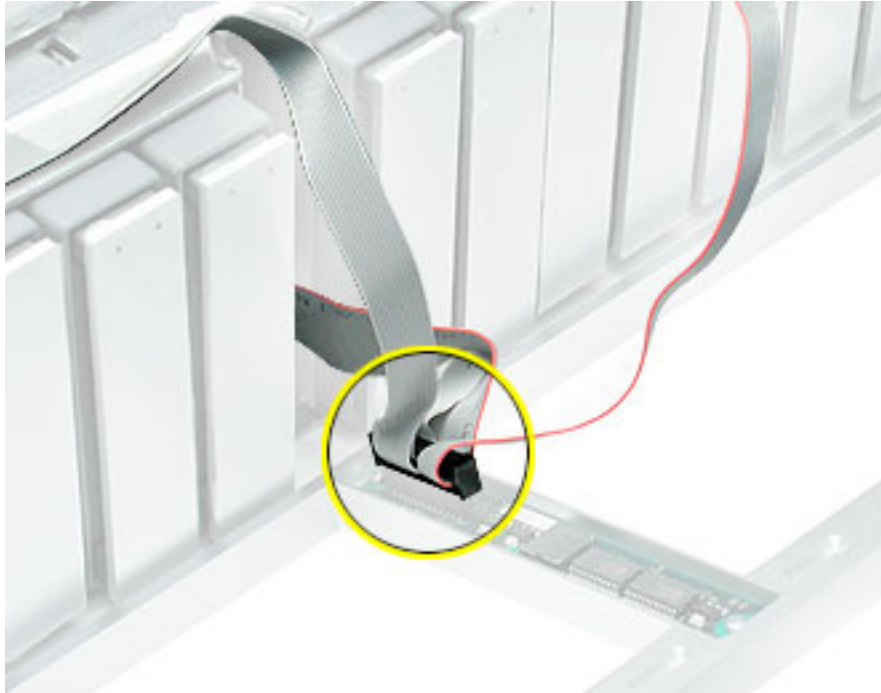

Note: If you are replacing the front bezel with a new bezel, you must transfer the following parts from the original bezel to the replacement bezel: left and right front panel boards and light pipes, front panel buttons, and center front panel board and light pipes.

Replacement Warning: When replacing the bezel, make sure you route the two branches of the front panel board cable straight up through the center front opening in the chassis. Otherwise, the front bezel may pinch the cable and damage it.





Midplane Board

Tools

The only tool required for this procedure is a Phillips screwdriver.

Preliminary Steps

Before you begin, remove the system from the rack and place it on a sturdy, flat surface and ESD mat. Then remove the following:

- All hard drives
- Both power supplies
- Both cooling modules
- Both controller modules
- Both backup batteries, if installed
- Top cover
- Front bezel

Part Location

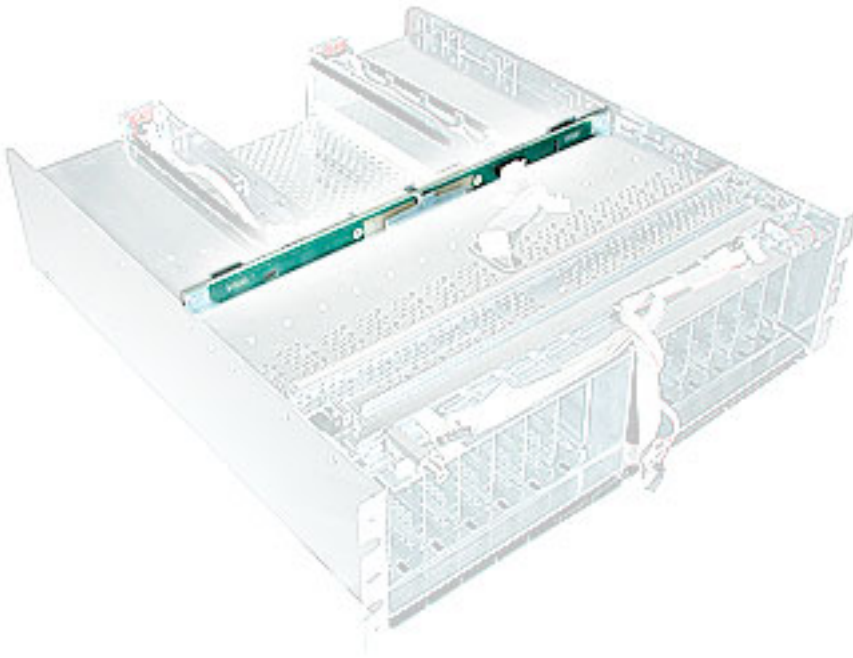

Procedure

1. Disconnect the front panel board cable and back panel board cables from the midplane board.
2. Grasp the front half of the chassis and rotate 90 degrees up.

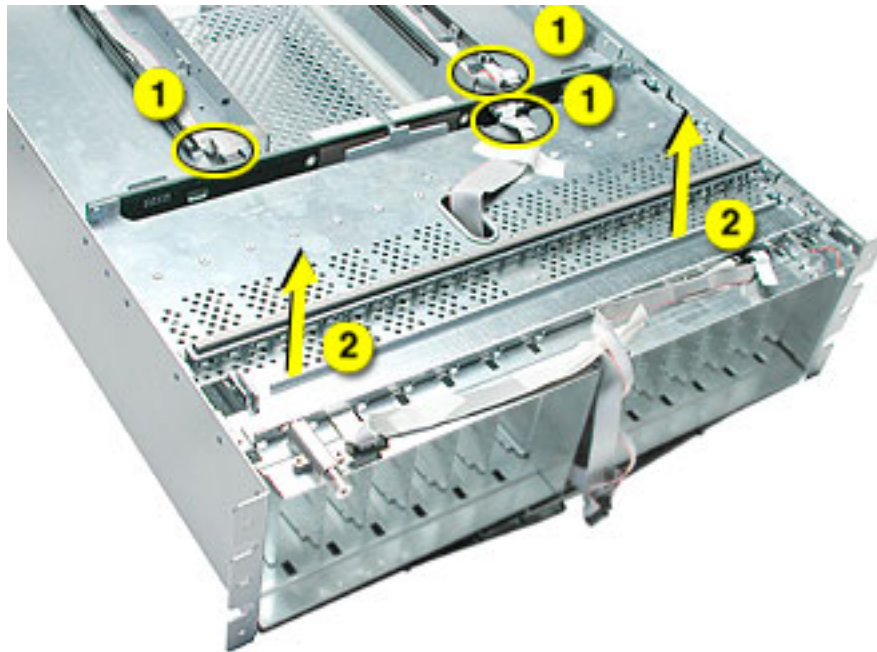

3. Remove the six midplane board mounting screws.
4. Remove the midplane from the bottom housing.

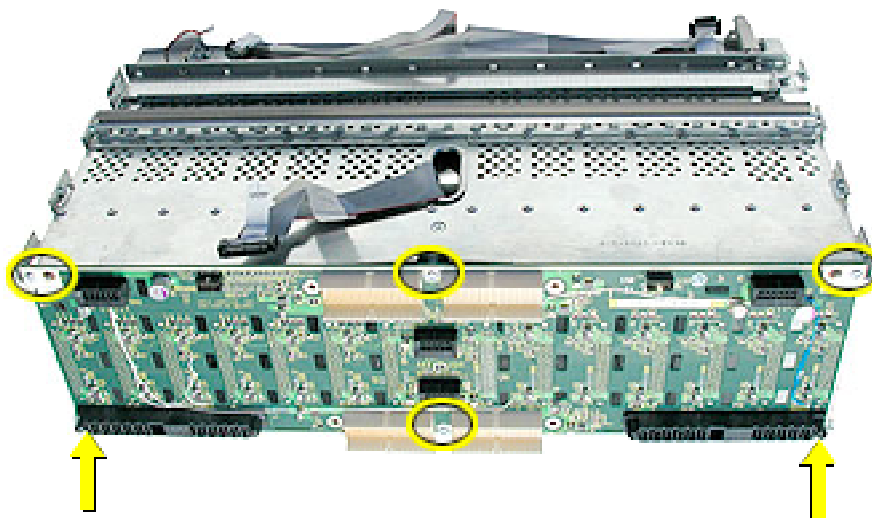

Replacement Note: When repositioning the front half of the chassis back into place, make sure the small hole in the center of the chassis fits over the peg in the chassis floor.

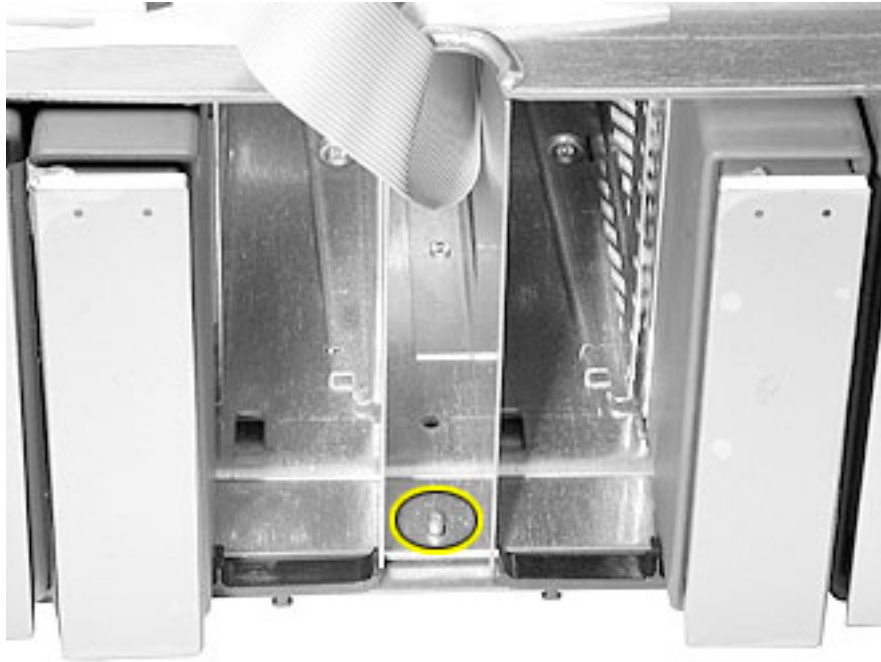



Center Front Panel Board

Tools

The only tool required for this procedure is a Phillips screwdriver.

Preliminary Steps

Before you begin, remove the system from the rack and place it on a sturdy, flat surface and ESD mat. Then remove the following:

- Top cover
- Front bezel

Part Location



Procedure

1. Remove the two mounting screws on the center front panel board.
2. Remove the board from the bezel.

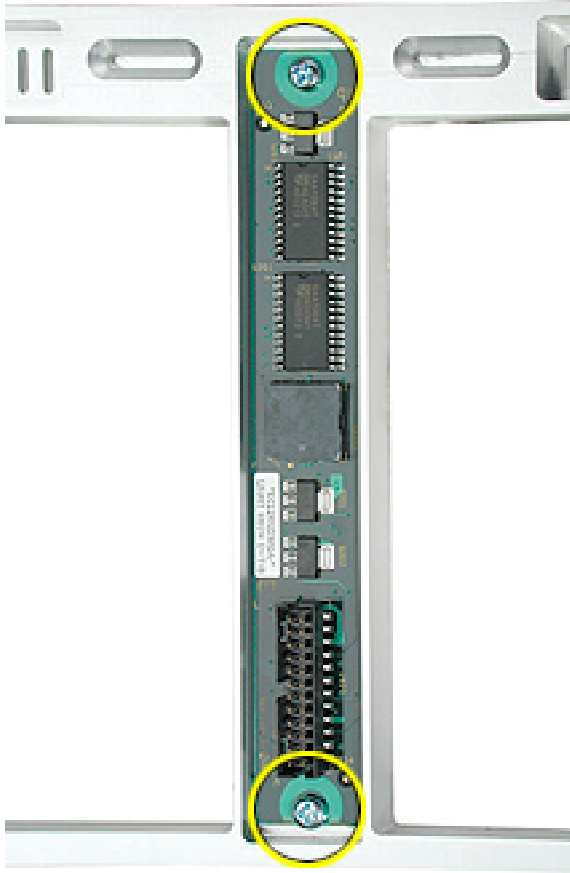



Center Front Light Pipe

Tools

The only tools required for this procedure are a Phillips screwdriver and a small flat-blade screwdriver.

Preliminary Steps

Before you begin, remove the system from the rack and place it on a sturdy, flat surface and ESD mat. Then remove the following:

- Top cover
- Front bezel
- Center front panel board

Part Location



Procedure

1. Using a flat-blade screwdriver, carefully pry up the top center light pipe and shield and remove them from the bezel.
2. Remove the bottom light pipe and shield from the bezel.





Left Front Panel Board

Tools

The only tool required for this procedure is a Phillips screwdriver.

Preliminary Steps

Before you begin, remove the system from the rack and place it on a sturdy, flat surface and ESD mat. Then remove the top cover.

Part Location

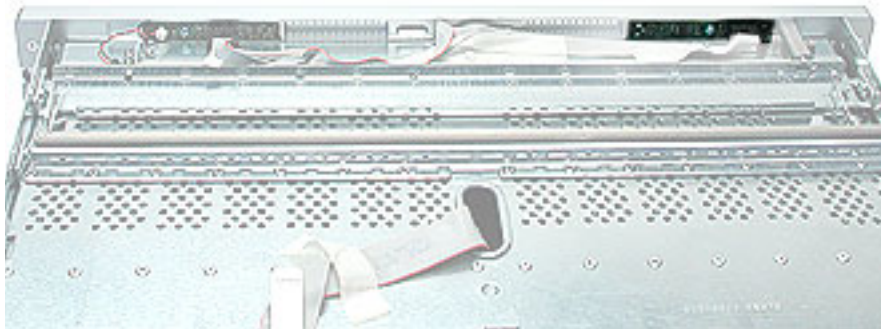

Procedure

1. Disconnect the front panel board cable from the left front panel board.
2. Remove the mounting screw.
3. Remove the board from the enclosure.





Right Front Panel Board

Tools

The only tool required for this procedure is a Phillips screwdriver.

Preliminary Steps

Before you begin, remove the system from the rack and place it on a sturdy, flat surface and ESD mat. Then remove the top cover.

Part Location

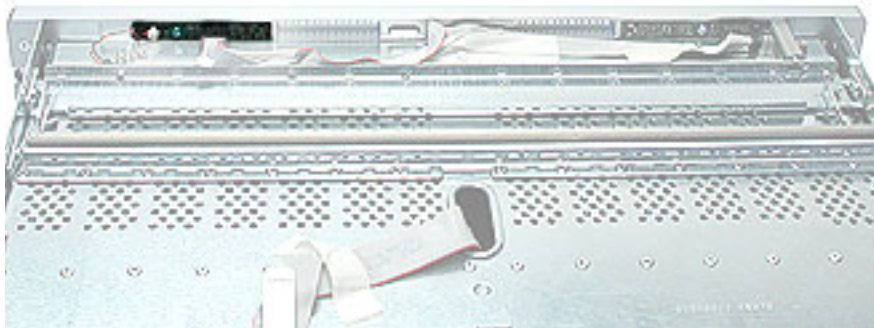

Procedure

1. Disconnect the locking switch cable and the front panel board cable from the right front panel board.
2. Remove the mounting screw.
3. Remove the board from the enclosure.





Left or Right Front Light Pipe

Tools

The only tools required for this procedure are a Phillips screwdriver and a flat-blade screwdriver.

Preliminary Steps

Before you begin, remove the system from the rack and place it on a sturdy, flat surface and ESD mat. Then remove the following:

- Top cover
- Front bezel
- Right or left front panel board

Note: The same light pipe is used behind both the left and right front panel boards.

Part Location

Light Pipe Behind Left Front Panel Board



Light Pipe Behind Right Front Panel Board



Procedure

1. Using a flat-blade screwdriver, carefully pry up the light pipe and shield.
2. Remove the light pipe and shield from the bezel.



Replacement Note: The light pipes come with a black plastic shield. Make sure the shield is in correct position over the light pipe before you place the light pipe back into the bezel.





Front Panel Buttons

Tools

The only tools required for this procedure are a Phillips screwdriver and either a flat-blade screwdriver or needlenose pliers.

Preliminary Steps

Before you begin, remove the system from the rack and place it on a sturdy, flat surface and ESD mat. Then remove the following:

- Top cover
- Front bezel
- Left front panel board

Note: The front panel button kit comes with both the system identifier button and the mute button.

Part Location



Procedure

1. Using needlenose pliers or a flat-blade screwdriver, carefully lift out the button shield from the bezel.
2. Pry up the buttons and remove them from the bezel.

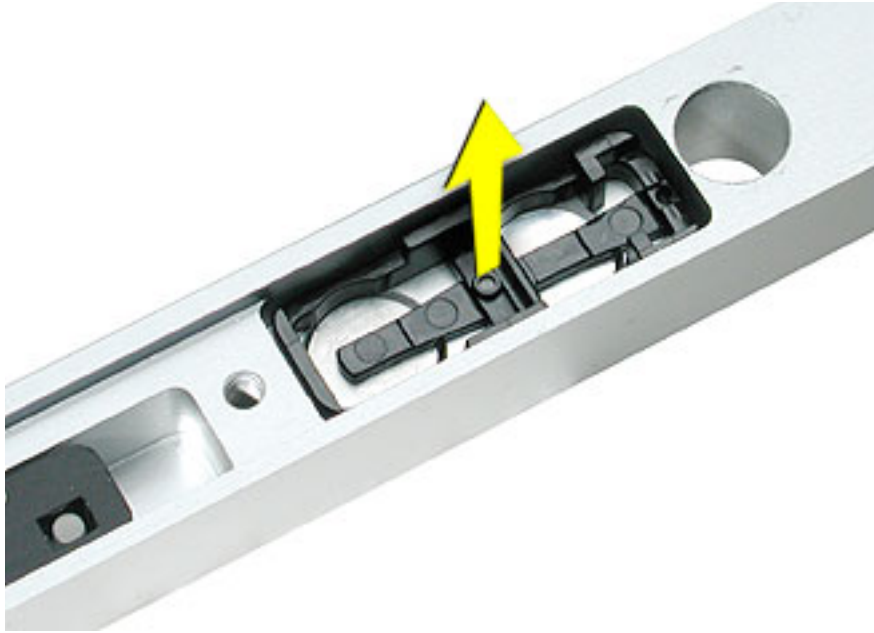

Replacement Note: When replacing the buttons, be sure to orient them as illustrated below.





Front Panel Cable

Tools

The only tool required for this procedure is a Phillips screwdriver.

Preliminary Steps

Before you begin, remove the system from the rack and place it on a sturdy, flat surface and ESD mat. Then remove the following:

- Top cover
- Front bezel

Part Location



Procedure

1. Disconnect the front panel cable from the midplane board.
2. Remove any tape holding the cable to the chassis.
3. Route the cable out through the center opening in the chassis and remove the cable from the enclosure.





Rear Panel Cable

Tools

The only tool required for this procedure is a Phillips screwdriver.

Preliminary Steps

Before you begin, remove the system from the rack and place it on a sturdy, flat surface and ESD mat. Then remove the top cover.

Part Location

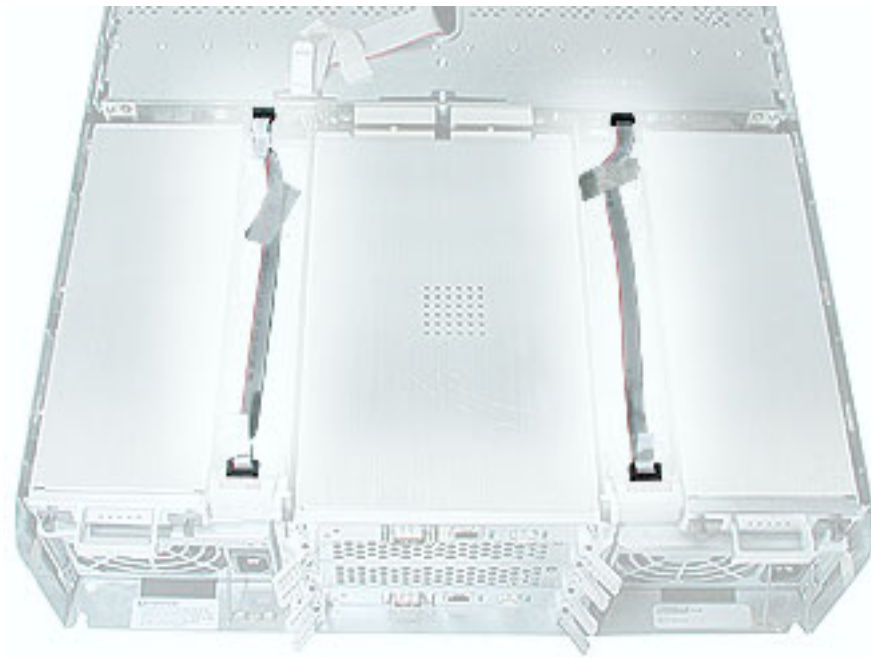

Procedure

1. Disconnect the rear panel cable from the midplane board and from the rear power button panel board or rear system ID panel board.
2. Remove the cable from the enclosure.

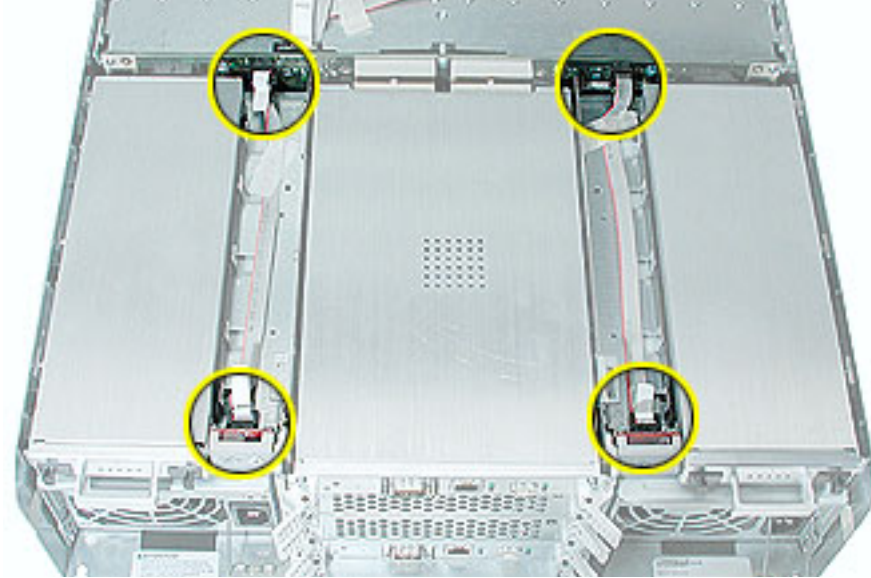



Rear System ID Panel Board

The rear system ID panel board includes the system ID and mute buttons.

Tools

The only tool required for this procedure is a small Phillips screwdriver.

Preliminary Steps

Before you begin, remove the system from the rack and place it on a sturdy, flat surface and ESD mat. Then remove the top cover.

Part Location



Procedure

1. Disconnect the rear panel cable from the rear system ID panel board.
2. Remove the two panel board mounting screws.
3. Remove the rear system ID panel board and its button cover from the enclosure.





Rear Power Button Panel Board

The rear power button panel board includes the on/off power button and light.

Tools

The only tool required for this procedure is a small Phillips screwdriver.

Preliminary Steps

Before you begin, remove the system from the rack and place it on a sturdy, flat surface and ESD mat. Then remove the top cover.

Part Location



Procedure

1. Disconnect the rear panel cable from the rear power button panel board.
2. Remove the two panel board mounting screws.
3. Remove the rear power button panel board and its button cover from the enclosure.





Troubleshooting
Xserve RAID



Diagnostic Tools

Xserve RAID includes built-in sensors that detect and report on hard drives, internal temperature, cooling module status or failure, and power status or failure. You can monitor the system's operation via these sensors and two diagnostic tools: indicator lights on the front and back of the system and remote monitoring software.

Status Lights

Status lights are located on the front and back panels of Xserve RAID. In addition, there are status lights on the host adapter card.

Front Panel Status Lights

The system's front panel status lights are shown in the figure and table below.

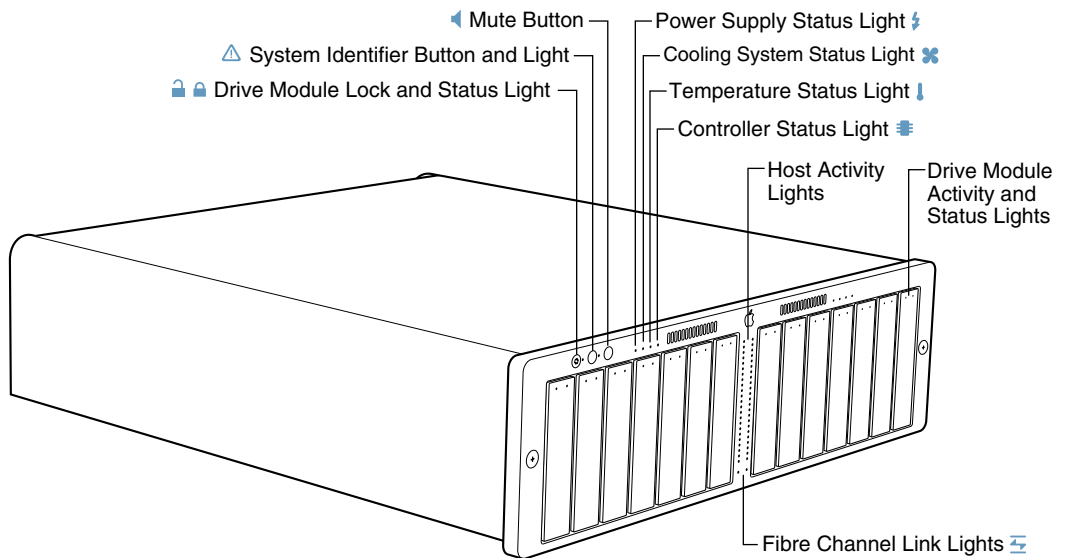

Table 1: Front Panel Status Lights

Indicator	LED Color	Description
Security lock	Yellow	Lock is engaged
System identifier	Yellow	Indicates a hardware error or that someone has toggled it on; check the server monitoring application for more information
Mute button	No LED	Press to turn off the alarm signalling an error condition
Power supplies	Green Red	OK Failure (See "Power Supply Status Lights")
Cooling modules	Green Red	OK Failure
Temperature	Green Red	OK Over temperature
RAID controller (one for each group of seven drives)	Green Red	OK Failure
Host activity	Blue	Two rows of 23 LEDs show level of fibre channel activity on each host channel
Fibre channel link	Green	Two LEDs indicate a link is established
Drive module (right LED)	Green Yellow Yellow/green flash Red	Powered and running; good Prefailure condition; replace drive Rebuilding RAID Problem or failure; replace drive
Drive module (left LED)	Blinking blue No light	Disk activity; do not remove drive No disk activity; drive can be removed

Back Panel Status Lights

The system's back panel status lights are shown in the figure below. General back panel status lights are listed in Table 3. Power supply status lights are in Table 4.

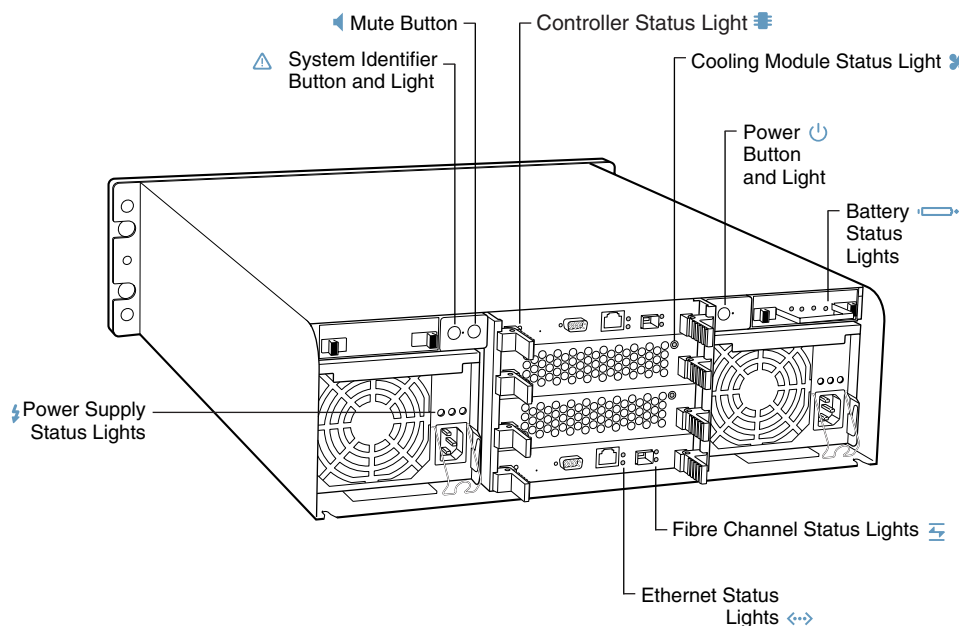

Table 2: General Back Panel Status Lights

Indicator	Color	Description
Power	White	On and OK
System identifier	Yellow	Indicates a hardware error or that someone has toggled it on
Mute button	No LED	Press to turn off alarm signalling an error
Power supplies		See "Power Supply Status Lights"
Cooling modules	Green	OK
Controllers	Green	OK
Ethernet link	Green Red	OK Failure
Fibre channel link	Green Red	OK Failure
Batteries	Green Red	Charged and OK Failure

Table 3: Power Supply Status Lights

Power Supply Conditions	Green LED	Yellow LED	Red LED
No AC power to either power supply	Off	Off	Off
Power supply failure or no AC power to this power supply	Off	Off	On
AC power present; standby outputs on	Blinking	Off	Off
Power supply DC outputs on and OK	On	Off	Off
Current limit	On	Off	Blinking
Predictive failure	On	Blinking/on	Off

Host Adapter Card Status Lights

The host adapter card's status lights are shown in the figure and table below.

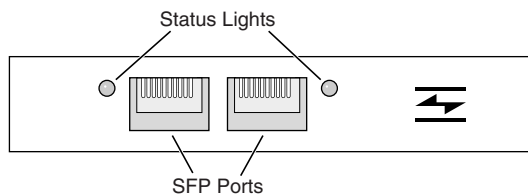

Table 4: Host Adapter Card Status Lights

LED Color/Status	Description
No light	Link established
Blinking green	Activity on the channel
Yellow	No link or there is an error condition

RAID Admin and Disk Utility

There are two applications for configuring and monitoring Xserve RAID systems: RAID Admin, included on a CD with the system, and Disk Utility, which is part of Mac OS X or Mac OS X Server.

RAID Admin is used for the following:

- Monitoring the status of one or more systems
- Creating or deleting RAID arrays
- Adjusting system settings, including system name and password, network address for each RAID controller, fibre channel communication speed, drive cache, controller cache, and LUN masking
- Setting up email notification for system alerts

Disk Utility is used to modify RAID arrays by adding striping or mirroring to existing RAID arrays.

Note: For more information on RAID Admin and Disk Utility, see the document “Using RAID Admin and Disk Utility” on the RAID Admin CD that comes with the Xserve RAID system.

Remote Monitoring

Use the RAID Admin application to monitor the Xserve RAID system from a host computer. The application allows monitoring in the following areas, each of which is represented by a tab at the top of the RAID Admin window:

- Info
- Components
- Drive & Arrays
- Fibre Channel
- Network

Note: For information on adding and deleting systems to the RAID Admin monitoring list, see the document “Using RAID Admin and Disk Utility.”

Info

Info reports system name, lock status, controller details, and whether there is a problem or power failure.

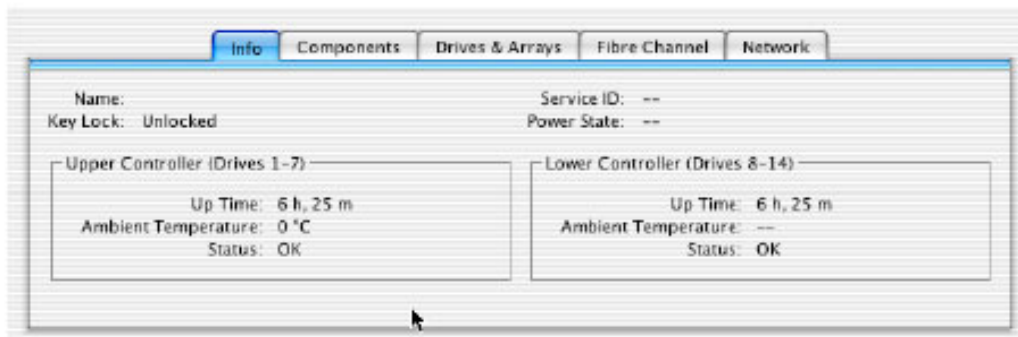

Components

Components shows the operating information about the power supplies, RAID controllers, cooling modules, and cache backup batteries. Clicking the button for a component displays its details.

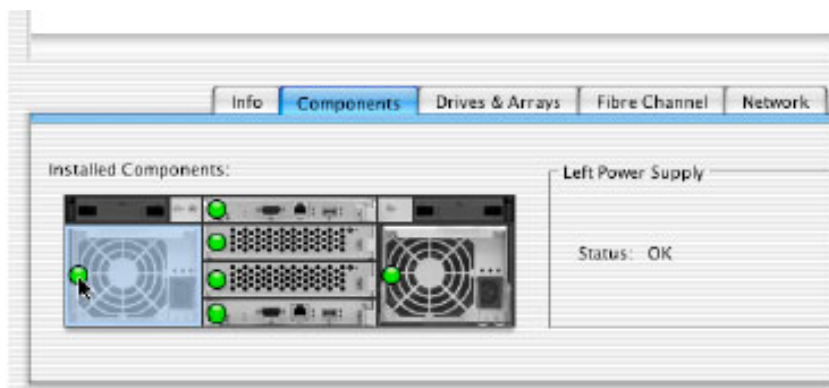

Drive & Arrays

Drives & Arrays shows details of each array, the drives in use, and the drives available. Choosing an array from the Array menu displays its details.

Fibre Channel

Fibre Channel shows information about each RAID controller and the type of fibre channel connection in use.

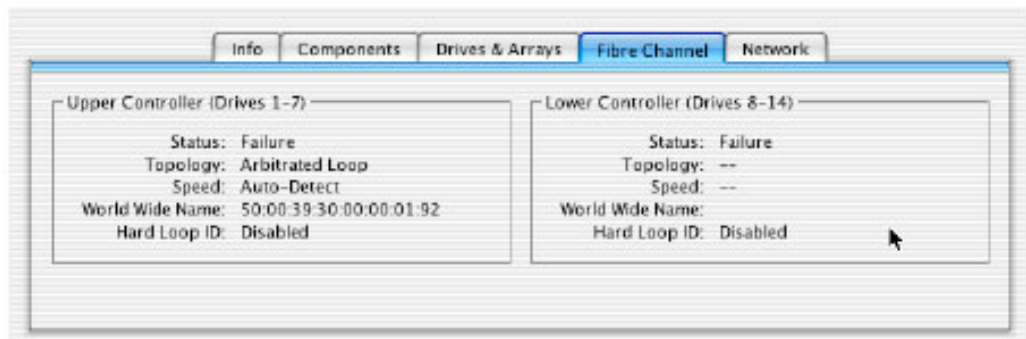

Network

Network displays the IP address and related network details for each RAID controller.

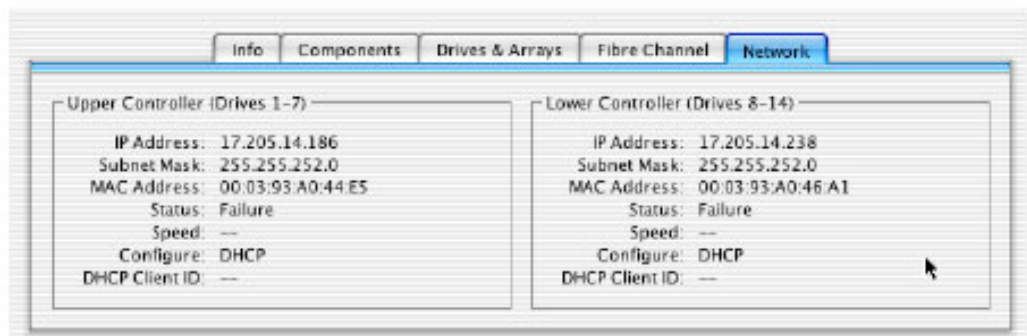



Block Diagram

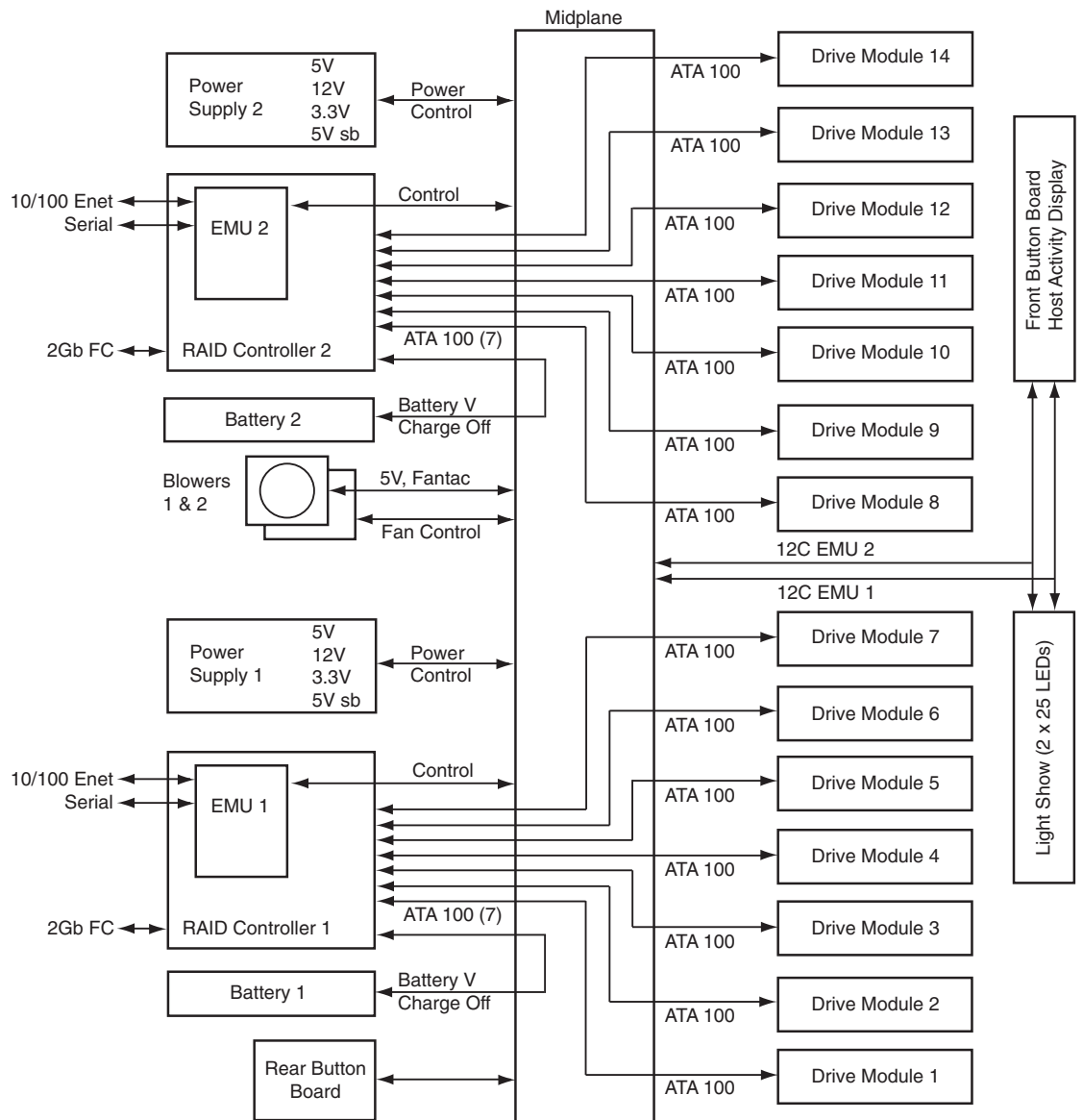

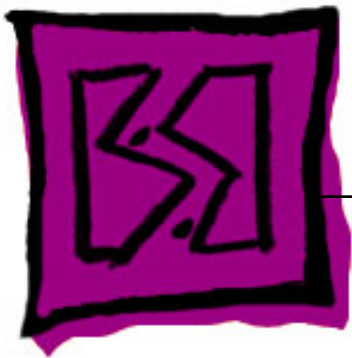

Views
Xserve RAID



Exploded View

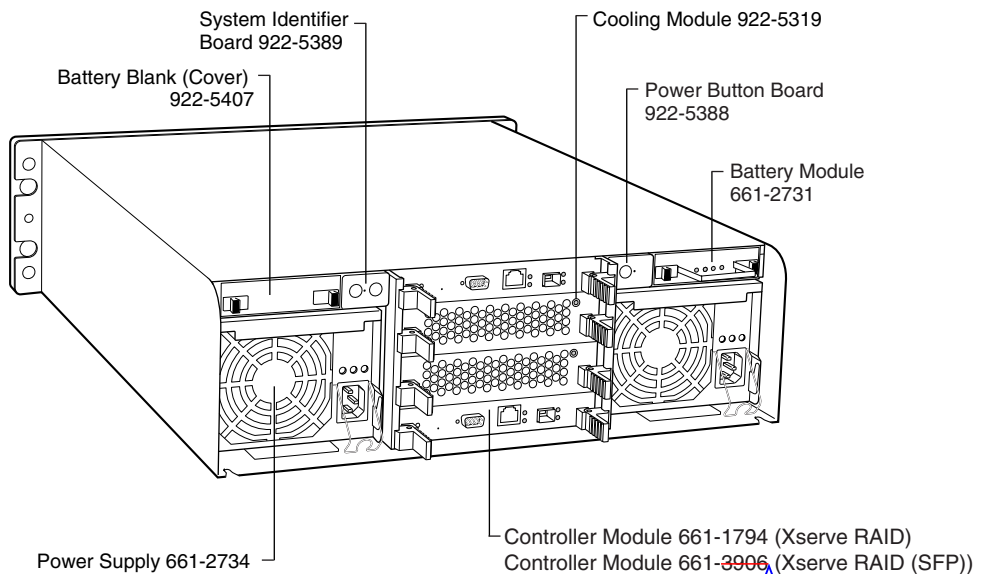
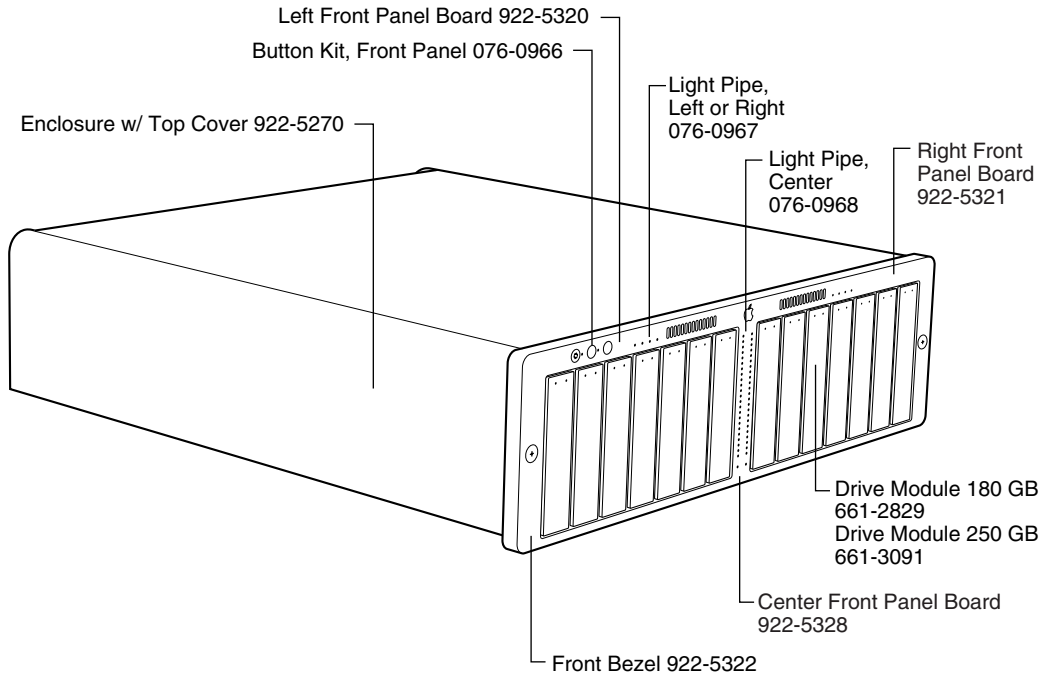



External Views

Front Panel

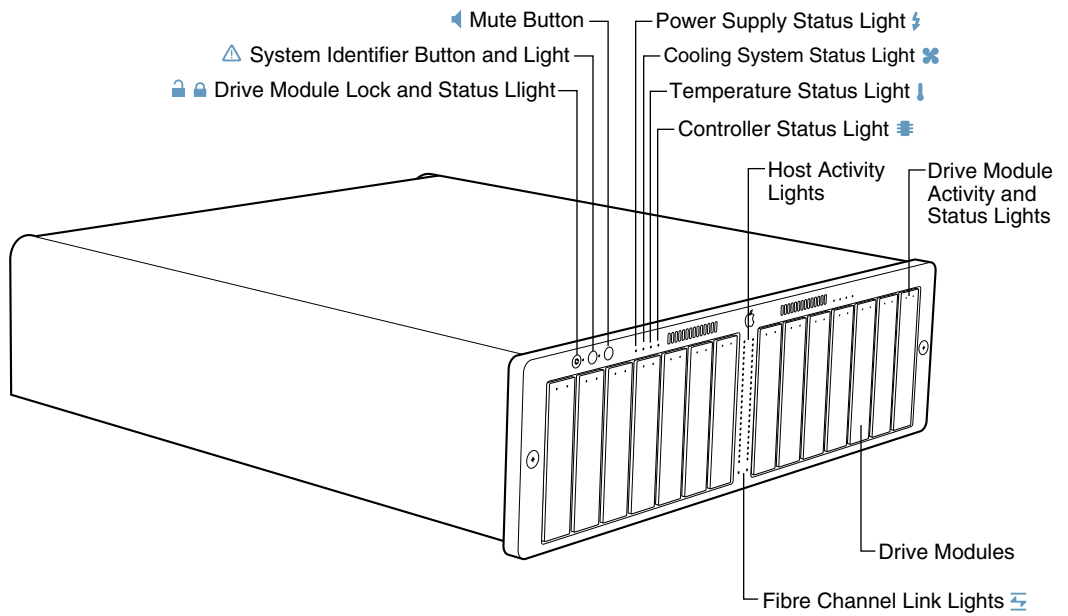

Back Panel

