



**SABRE
EIGHT-INCH MODULE DRIVE**

**PA8B1
PA8E1**

**GENERAL DESCRIPTION
OPERATION
INSTALLATION AND CHECKOUT
PARTS DATA**

WARNING

Do not attempt to install, operate, or repair the unit before you read the important safety information located directly after the revision record in this manual. Failure to follow that and other safety precautions in this manual could cause injury to yourself and others.

This equipment generates, uses and can radiate radio frequency energy and if not installed and used in accordance with the instructions manual, may cause interference to radio communications. It has been tested and found to comply with the limits for a Class A computing device pursuant to Subpart J of Part 15 of the FCC Rules, which are designed to provide reasonable protection against such interference when operated in a commercial environment. Operation of this equipment in a residential area is likely to cause interference, in which case the user, at his own expense, will be required to take whatever measures may be required to correct the interference.

If the operator or status/control panel (component assembly) is not installed in the inner drawer, it is your responsibility to provide any additional RFI shielding or grounding needed to ensure FCC Class A compliance.

This digital apparatus does not exceed the Class A limits for radio noise for digital apparatus set out in the Radio Interference Regulations of the Canadian Department of Communications.

VORSICHT

Versuchen Sie nicht, das Gerät zu installieren, zu betreiben oder zu reparieren bevor Sie die in der Anlage B aufgeführten Installations- und Betriebserfordernisse sorgfältig gelesen haben. Die Nichtbeachtung dieser und weiterer in diesem Manual gegebenen Informationen kann Verletzungen Ihrer selbst und Anderer zur Folge haben.

AVERTISSEMENT

Ne tentez pas d'installer, de mettre en marche, ou de dépanner cet appareil avant d'avoir lû les instructions d'installation et de fonctionnement données dans l'appendice C. A défaut d'observer ceci ainsi que les autres informations de ce manuel vous pourriez mettre votre propre santé en danger, ou celle d'autrui.

Le présent appareil numérique n'émet pas de bruits radioélectriques dépassant les limites applicables aux appareils numériques de la classe A prescrites dans le Règlement sur le brouillage radioélectrique édicté par le ministère des Communications du Canada.

PRECAUCION

No intente instala, operar ó reparar está unidad antes de leer los requerimientos de instalación y operación dados en el Apéndice D. Cualquier negligencia en seguir esta u otra información dada en esta manual puede causarle daños a uno mismo u otros.

REVISION RECORD

REVISION	DESCRIPTION
01 (09-15-86)	Preliminary manual.
02 (09-26-86)	Preliminary edition. This edition obsoletes all previous editions. Subject to change without notice.
A (11-15-86)	Original release. This edition obsoletes all previous editions.
B (05-21-87)	Incorporate Class I ECOS DJ29230, 29245, 29311; Class II ECO DJ29273; Technical Changes. Added PABE1. This edition obsoletes all previous editions.
C (01-29-88)	Incorporate Class I ECOS DJ29263, 29275, 29279, 29291, 29311, 29320, 29363, 29364, 29365, 29374, 29384, 29390, 29391, 29406, 29415, 29416, 29418, 29419, 29421, 29422, 29425, 29431, 29453, 29465, 29561, 29667, 29668; Class II ECOS DJ29282, 29310, 29328, 29354, 29375, 29376, 29382, 23989, 29400, 29454, 29455, 29544; Technical changes. Added table for optional parts. Documented sweep cycle and 7-disk module. This edition obsoletes all previous editions.
D (08-08-88)	Incorporated in this edition are: Class I ECOS DJ29699, 29772, 29775, 29788, 29855; Class II ECOS DJ29504, 29517, 29585, 29616, 29622, 29633, 29639, 29653, 29777, 29816; Clarified switch settings, additional sweep cycle information, Spanish language operating instructions and miscellaneous technical and editorial changes. This edition obsoletes all previous editions.

REVISION LETTERS I, O, Q AND X ARE NOT USED.

© 1986,87,88,89
 By Imprimis Technology Incorporated
 Technical Publications Department
 5950 Clearwater Drive
 Minnetonka, MN 55343

We value your comments. A Comment Sheet is provided at the back of this manual.

Printed in the United States of America

REVISION RECORD (Contd)

REVISION	DESCRIPTION
E (03-11-88)	Incorporate Class I ECOS DJ29882, 29922, 29936, 40208, 40228, 40229, 40234, 40273, 40280; Class II ECOS DJ29861, 29930, 29985, 29987, 40138, 40163, 40221, 40227, 40247, 40250. Technical changes. Documented PA8B1E and PA8E1E drives.

MANUAL TO EQUIPMENT LEVEL CORRELATION

This manual reflects the equipment configurations listed below.

EXPLANATION: Locate the equipment type and series code number, as shown on the Equipment Configuration Log, in the list below. Immediately to the right of the series code number is an FCO number. If that number and all of the numbers underneath it match all of the numbers on the Equipment Configuration Log, then this manual accurately reflects the equipment.

This correlation sheet also applies to the following related manuals:

Pub. No. 83325640 Rev. B

Pub. No. 83325650 Rev. C

EQUIPMENT TYPE	SERIES CODE	WITH FCOs	COMMENTS
PA8B1	01-12	None	
PA8E1	01-04	None	

LIST OF EFFECTIVE PAGES

This manual is at revision E. Each page in your manual should be at the revision level listed below. The "Div" is a colored divider page.

PAGE/REV	PAGE/REV	PAGE/REV	PAGE/REV	PAGE/REV	
Cover	-	Blank	-	3-28	E
Warnings	-	S-2 Div	-	3-28.1	E
Title P	-	Blank	-	Blank	-
f-2	E	2-1	D	3-29	E
f-3	E	2-2	B	3-30	E
Blank	-	2-3	C	3-31	C
f-5	E	2-4	D	3-32	E
Blank	-	2-5	D	3-33	E
f-7	E	2-6	C	3-34	E
Blank	-	2-7	B	3-35	E
f-9	E	2-8	C	3-36	C
f-10	E	S-3 Div	-	3-37	D
f-11	E	Blank	-	3-38	D
Blank	E	3-1	D	3-39	D
f-13	E	3-2	A	3-40	D
f-14	E	3-3	D	3-41	D
f-15	E	3-4	C	3-42	D
f-16	E	3-5	E	3-43	D
f-17	E	3-6	E	Blank	-
Blank	E	3-7	C	S-4 Div	-
f-19	E	3-8	E	Blank	-
f-20	E	3-9	A	4-1	E
f-21	E	3-10	A	4-2	E
f-22	E	3-11	A	4-3	E
f-23	E	3-12	E	4-4	E
f-24	E	3-13	D	4-5	E
S-1 Div	-	3-14	E	4-6	A
Blank	-	3-15	C	4-7	E
1-1	E	3-16	D	4-8	C
1-2	E	3-17	C	4-9	D
1-3	E	3-18	A	4-10	D
1-4	C	3-19	C	4-11	E
1-5	B	3-20	C	4-12	A
1-6	C	3-21	C	4-13	C
1-7	B	3-22	E	4-14	E
1-8	D	3-23	C	4-15	E
1-9	C	3-24	D	Blank	-
1-10	B	3-25	E	4-17	E
1-11	E	3-26	E	4-18	E
		3-27	E	4-19	E
				4-20	E
				4-21	E
				Blank	-
				4-23	E
				Blank	-
				4-25	E
				Blank	E
				4-27	E
				4-28	E
				4-29	E
				4-30	E
				4-31	E
				Blank	-
				App A Div	-
				Blank	-
				A-1	D
				A-2	D
				A-3	B
				A-4	B
				A-5	D
				A-6	D
				A-7	E
				A-8	E
				A-8.1	E
				Blank	-
				A-9	E
				A-10	D
				A-11	C
				A-12	E
				A-13	C
				A-14	C
				A-15	C
				A-16	C
				A-17	C
				A-18	C
				A-19	C
				A-20	C
				A-21	C
				A-22	E
				A-23	C
				A-24	C
				A-25	C
				A-26	C
				A-27	C
				A-28	C
				App B Div	-
				Blank	-
				B-1	E
				B-2	E
				B-3	C
				B-4	C
				B-5	D
				B-6	C
				B-7	C
				Blank	-
				App C Div	-
				Blank	-
				C-1	E
				C-2	E
				C-3	C
				C-4	C
				C-5	D
				C-6	C
				C-7	C
				Blank	-
				App D Div	-
				Blank	-
				D-1	E
				D-2	E
				D-3	D
				D-4	D
				D-5	D
				D-6	D
				D-7	D
				Blank	-
				Cmt Sht	-
				Rtn Env	-
				Blank	-
				Cover	-

PREFACE

This manual contains maintenance information for the Imprimis PA8B1 and PA8E1 eight-inch module drive. It provides information to persons who operate, install, and check out the drive. Persons involved in training, troubleshooting, and repair activities should obtain copies of the Hardware Maintenance Manual, Volumes 2 and 3 (listed below) that pertain to the drives they are maintaining.

As you use these manuals, you will find information specific either to the PA8B1 drives or to the PA8E1 drives. Specific references to one type of drive or the other are keyed to the nominal drive capacity as follows:

- PA8B1 drives are referred to as 368 MB drives.
- PA8E1 drives are referred to as 500 MB drives.

The Configuration Chart lists other differences between the individual drives covered in these manuals.

The information in this manual is presented as follows:

- Section 1 - General Description. Describes equipment functions and specifications.
- Section 2 - Operation. Describes and illustrates the location and use of all controls and indicators, and provides operating procedures.
- Section 3 - Installation and Checkout. Describes site requirements, unpacking, inspection, installation, and checkout.
- Section 4 - Parts Data. Contains illustrated parts breakdown and spare parts list.
- Appendix A - Diagnostic Testing and Status Code Summary. Provides simplified troubleshooting information.
- Appendix B - Installation and Operating Requirements (German). Contains basic installation and operation information in the German language.
- Appendix C - Installation and Operating Requirements (French). Contains basic installation and operation information in the French language.

Appendix D - Installation and Operating Requirements (Spanish). Contains basic installation and operation information in the Spanish language.

New features, technical changes, additions, and deletions in this manual are indicated in the following ways:

- A vertical bar in the outer margin of a page marks the changed area.
- A dot by the page number indicates the entire page contains new or changed information.
- A vertical bar by the page number indicates the information was moved from another page, but there were no technical or editorial changes.

The following manuals apply to the SABRE and are available from:

Imprimis Technology Incorporated
Customer Services
5950 Clearwater Drive
Minnetonka, MN 55343

Phone: (612) 931-8612
Fax: (612) 931-8817

<u>Publication No.</u>	<u>Title</u>
83325630	PA8B1/PA8E1 Hardware Maintenance Manual, Volume 1
83325640	PA8B1/PA8E1 Hardware Maintenance Manual, Volume 2 (contains theory of operation and maintenance)
83325650	PA8B1/PA8E1 Hardware Maintenance Manual, Volume 3 (contains diagrams)
83325810	Reference Card (summarizes status codes and diagnostic operation)

For more information about the SCSI interface, you can request copies of the following interface specification from your Imprimis sales representative:

<u>Specification No.</u>	<u>Title</u>
64721701	Interface Specification for the Imprimis Large Disk Division Small Computer System Interface (SCSI)

CONFIGURATION CHART

Equipment Number*	Interface	Unformatted Capacity (MB)	Sector Size (Bytes)
PA8B1A	SCSI - Differential	368	512
PA8B1B	SCSI - Single Ended	368	512
PA8B1C	SCSI - Differential	368	256
PA8B1D	SCSI - Single Ended	368	256
PA8B1E	SCSI - Differential	368	256
PA8E1A	SCSI - Differential	500	512
PA8E1B	SCSI - Single Ended	500	512
PA8E1C	SCSI - Differential	500	256
PA8E1D	SCSI - Single Ended	500	256
PA8E1E ⁺	SCSI - Differential	500	512

*Refer to section 4 for equipment listings that include painted parts and other supplied options.

⁺This drive has an additional voltage converter to permit operation with a power supply providing fewer output voltages than the standard supply.

CONTENTS

Configuration Chart	f-11
Important Safety Information and Precautions	f-19
Abbreviations	f-21
1. GENERAL DESCRIPTION	
Introduction	1-1
Interface Description	1-1
Functional Description	1-1
Physical Description	1-5
Equipment Configuration	1-9
General	1-9
Equipment Identification	1-10
General	1-10
Equipment Identification Number	1-10
Series Code	1-10
Part Number	1-11
Serial Number	1-11
Equipment Configuration Log	1-11
Manual to Equipment Level Correlation	1-11
2. OPERATION	
Introduction	2-1
Switches and Indicators	2-1
Starting the Drive (Drives with Operator Panel)	2-4
Stopping the Drive (Drives with Operator Panel)	2-5
Operating Drives with No Operator Panel	2-5
Replacing or Cleaning the Air Filter	2-6

3. INSTALLATION AND CHECKOUT

Introduction	3-1
Site Requirements	3-1
Electrostatic Discharge Protection	3-1
Environmental Requirements	3-2
Space Requirements	3-3
Power Requirements	3-5
Grounding Requirements	3-5
Safety Grounding	3-5
System Grounding	3-6
Interface Requirements	3-8
Unpacking, Inspection and Repackaging	3-12
Unpacking	3-12
Inspection	3-12
Repacking	3-12
Installation Procedures	3-13
General	3-13
Power Supply Voltage Conversion	3-13
Mounting 2X Drawer in Rack	3-14
Mounting Front Panel	3-17
Mounting Operator Panel or Status/Control Panel	3-19
Mounting Drive and Power Supply in 2X Drawer	3-25
Alternate Methods for Installing the Drive	3-26
System I/O Cabling	3-28.1
System Grounding	3-30
Setting Circuit Board Switches	3-32
Sweep Cycle Information	3-40
Which Drives Have The Sweep Cycle Feature	3-40
How To Enable The Sweep Cycle Feature	3-40
How To Disable The Sweep Cycle Feature	3-41
Checkout	3-41
Power On Sequence Enabled	3-41
Power On Sequence Disabled	3-43
Start/Stop Unit Command	3-43

4. PARTS DATA

Introduction	4-1
Field Replaceable Parts List	4-1
Manufacturer's Recommended Spare Parts	4-2
Accessories	4-3
Card Interchangeability Chart	4-3
Eight-Inch Module Drive	4-5
Drive Electronics Assembly	4-13
DC Voltage Converter Kit Assembly	4-15

A. DIAGNOSTIC TESTING AND STATUS CODE SUMMARY

Introduction	A-1
Switches and Indicators	A-2
Power On Testing	A-7
SCSI I/O Board Initialization	A-7
Inquiry Command	A-8.1
Receive Diagnostic Results Command	A-10
Additional Length Bytes	A-10
FRU Code	A-10
Error Code	A-10
Reading the I/O Board LEDs	A-12
Drive Testing	A-16
Diagnostic Testing	A-16
Test Selection Procedure	A-16
Test Descriptions	A-18
Test 00 -- Display Drive Operating Status Log	A-18
Test 01 -- Display Fault Log	A-18
Test 04 -- Calculate Three Most Likely Field Replaceable Units	A-19
Test 05 -- Servo Test	A-20
Test 06 -- Clear Drive Operating Status Log	A-21
Test 07 -- Clear Fault Log	A-21
Test 08 -- Direct or Continuous Seeks	A-21
Test 09 -- Random Seek	A-22
Test 0C -- Display EPROM Part Number	A-22

Test OE -- Return to Zero	A-22
Test 2F -- I/O Test	A-23
Drive Status Codes	A-23

B. INSTALLATION AND OPERATING REQUIREMENTS (GERMAN)

C. INSTALLATION AND OPERATING REQUIREMENTS (FRENCH)

D. INSTALLATION AND OPERATING REQUIREMENTS (SPANISH)

FIGURES

1-1	Drive Functional Block Diagram	1-6
1-2	Drive Major Assemblies	1-7
2-1	Switches and Indicators	2-2
2-2	Air Filter Replacement	2-7
2-3	Power Supply On/Standby Switch	2-8
3-1	Drive Space Requirements	3-4
3-2	Typical Line Current Versus Start-up Time	3-7
3-3	System I/O Cabling	3-8
3-4	Power Supply Voltage Conversion	3-15
3-5	AC Power Cables	3-16
3-6	2X Drawer Installation	3-17
3-7	Mounting Front Panel	3-18
3-8	Mounting the Status/Control Panel	3-20
3-9	Mounting the Operator Panel	3-21
3-10	Mounting Drive and Power Supply in 2X Drawer	3-22
3-11	Remote Power Supply Cabling	3-27
3-11.1	Cabling for a Drive with a Voltage Converter	3-28
3-12	I/O Cable Attachment	3-28.1
3-13	System Grounding Diagram	3-31
3-14	System (DC) Ground Connection	3-31
3-15	I/O Board Switches	3-33

3-16	Control Board Switches and Jumpers	3-36
3-17	How To Set DIP Switches	3-39
4-1	Eight-Inch Module Drive	4-4
4-2	Drive Electronics Assembly	4-12
4-3	DC Voltage Converter Kit Assembly	4-14
A-1	Switches and Indicators	A-3
A-2	Example of LCD (Liquid Crystal Display)	A-24

TABLES

1-1	Drive Specifications	1-2
2-1	Operator Panel Switches and Indicators	2-3
3-1	Environmental Requirements	3-2
3-2	Power Requirements	3-6
3-3	Single Ended Cable Pin Assignments	3-9
3-4	Differential Cable Pin Assignments	3-10
3-5	I/O Board Switches	3-34
3-6	Control Board Switches	3-37
3-7	Control Board Jumpers	3-38
4-1	Optional Parts	4-17
4-2	Recommended Spare Parts	4-23
4-3	Accessories	4-25
A-1	Drive Switches and Indicators	A-4
A-2	Inquiry Data	A-8.1
A-3	Diagnostic Data Return Bytes	A-10
A-4	Online FRU Codes	A-11
A-5	Error Codes	A-11
A-6	Power On Test Failure	A-17
A-7	Offline FRU Codes	A-20
A-8	Drive Status Codes	A-24

IMPORTANT SAFETY INFORMATION AND PRECAUTIONS

Use of proper safety and repair techniques is important for safe, reliable operation of this unit. Service should be done only by qualified persons. We recommend the procedures in this manual as effective ways of servicing the unit. Some procedures require the use of special tools. For proper maintenance and safety, you must use these tools as recommended.

The procedures in this manual and labels on the unit contain warnings and cautions that must be carefully read and followed to minimize or eliminate the risk of personal injury. The warnings point out conditions or practices that may endanger you or others. The cautions point out conditions or practices that may damage the unit, possibly making it unsafe for use.

You must also understand that these warnings and cautions are not exhaustive. We cannot possibly know, evaluate, and advise you of all the ways in which maintenance might be performed or the possible risk of each technique. Consequently, we have not completed any such broad evaluation. If you use a non-approved procedure or tool, first ensure that the method you choose will not risk either your safety or unit performance.

For the safety of yourself and others, observe the following warnings and precautions.

- Perform all maintenance by following the procedures in this manual.
- Follow all cautions and warnings in the procedures and on unit labels.
- Use the special tools called out in the procedures.
- Use sound safety practices when operating or repairing the unit.
- Use caution when troubleshooting a unit that has voltages present. Remove power from unit before servicing or replacing parts.
- Wear safety glasses when servicing units.
- Wear safety shoes when removing or replacing heavy parts.
- Use only designated Imprimis replacement parts. Non-Imprimis replacement parts can adversely affect safety in addition to degrading reliability, increasing maintenance downtime, and voiding warranty coverage.

(continued on next page)

- Use care while working with the power supply because line voltages are always present when the ac power cord is connected to a power source. Setting the power supply switch to position "0" disables dc power to the drive but has no effect on ac power within the supply. For complete safety, remove the ac power plug from the site power outlet.
- In case of fire or other emergency, isolate the drive from main power by removing the drive power plug from the ac outlet. In situations where pulling the plug is not possible or practical, use the system main power disconnect to isolate the drives from main power.
- When the drive is mounted in an equipment rack or cabinet, ensure that the internal temperature of the rack or cabinet will not exceed the limits defined for the drive. Where units are stacked vertically, pay special attention to the top where temperatures are usually highest.
- This drive is designed to be installed and operated in accordance with IEC380, IEC435, VDE805, VDE806.
- Follow the precautions listed under Electrostatic Discharge Protection.
- If the power supply is placed on a bench for testing, position the supply so all ventilation holes are open, to allow proper air flow to internal components.
- Do not attempt to disassemble the module. It is not field repairable. Replace the entire module assembly if it is defective.
- Do not operate the drive over an extended period of time without the top cover installed.
- If the power supply is connected to an IT network, ensure that the input voltage is limited to 230 volts.
- Do not attempt to disassemble the power supply. It is not field repairable. Replace the entire supply if it is defective.
- Always deenergize drive before removing or installing circuit boards, cables, or any other electrical components.
- If you do not use the recommended power supply, ensure the selected power supply meets the specifications in this manual and is designed to be used in accordance with IEC380, IEC435, VDE805, VDE806.

ABBREVIATIONS

A	Ampere	CNTR	Counter
ABV	Above	COMP	Comparator
ac	Alternating Current	CONT	Control
ADD	Address	CONTD	Continued
ADDR	Address	CT	Center Tap
ADJ	Adjust	CYL	Cylinder
ADRS	Address	D/A	Digital to Analog
AGC	Automatic Gain Control	dc	Direct Current
ALT	Alternate	DET	Detect
AM	Address Mark	DIFF	Differential
AME	Address Mark Enable	DIP	Dual In-line Package
AMP	Amplifier, Ampere	DIV	Division
ASSY	Assembly	DLY	Delay
BLW	Below	DRVR	Driver
C	Celsius	ECL	Emitter Coupled Logic
CB	Circuit Breaker	ECO	Engineering Change Order
CDA	Complete Drive Assembly	EMD	Eight-Inch Module Drive
CH	Channel	EN	Enable
CHK	Check	ENBL	Enable
CLK	Clock	EXT	External
CLR	Clear	F	Fahrenheit, Fuse
cm	Centimetre		

ABBREVIATIONS (Contd)

FCO	Field Change Order	kg	Kilogram
FDBK	Feedback	kPa	Kilopascal
FIG	Figure	kW	Kilowatt
FLT	Fault	lb	Pound
FRU	Field Replaceable Unit	LCD	Liquid Crystal Display
ft	Foot	LED	Light Emitting Diode
FTU	Field Test Unit	LSI	Large Scale Integration
FWD	Forward	LTD	Lock to Data
GND	Ground	LUN	Logical Unit Number
HD	Head	m	Metre
HEX	Hexagon	MAX	Maximum
Hg	Mercury	MB	Megabyte
HR	High Resolution	MEM	Memory
HYST	Hysteresis	MHz	Megahertz
Hz	Hertz	mm	Millimeter
IC	Integrated Circuit	MPU	Microprocessor Unit
IDENT	Identification	MRK	Mark
in	Inch	ms	Millisecond
IND	Index	MTR	Motor
INTRPT	Interrupt	mV	Millivolt
I/O	Input/Output	NC	No Connection
IPB	Illustrated Parts Breakdown		

ABBREVIATIONS (Contd)

NORM	Normal	REF	Reference
NRZ	Non Return to Zero	REQ	Request
ns	Nanosecond	RES	Resolution
OC	On Cylinder	REV	Reverse, Revision
OS	One-Shot	RGTR	Register
OSC	Oscillator	r/min	Revolutions per Minute
P	Plug	RTZ	Return to Zero
PD	Peak Detect	R/W	Read/Write
pF	Picofarad	s	Second
PFTU	Programmable Field Test Unit	S/C	Series Code
PG	Page	SCSI	Small Computer System Interface
PHH	Phillips Head	SEL	Select
PLO	Phase Lock Oscillator	SEQ	Sequence
PROC	Procedure	SPD	Speed
PROG	Programmable	SS	Sector Switch
PS	Power Supply	T	Tracks to go
PWR	Power Supply	TF	Thread Forming
RAM	Random Access Memory	TIM	Timer
RCVR	Receiver	TP	Test Point
RD	Read	TSP	Troubleshooting Procedure
RDY	Ready		

ABBREVIATIONS (Contd)

TTL	Transistor-Transistor Logic	W PROT	Write Protect
V	Volts, Voltage	W+R	Write or Read
Vbb	Bias Voltage	W·R	Write and Read
VCC	Bias Voltage	WRT	Write
VCO	Voltage Controlled Oscillator	XFR	Transfer
W	Watts	Ω	Ohms
W/	With	\$	Hexadecimal Address
W/O	Without	uF	Microfarad
		us	Microsecond

SECTION 1

GENERAL DESCRIPTION

GENERAL DESCRIPTION

1

INTRODUCTION

The SABRE PA8B1 and PA8E1 eight-inch module drives are high speed, random access disk drives. They communicate with an initiator using the Small Computer System Interface (SCSI). The total unformatted storage capacity is 368 megabytes for the PA8B1 and is 500 megabytes for the PA8E1. Equipment specifications are listed in table 1-1.

The remainder of this section provides a general description of the drive and is divided into the following areas:

- Interface Description -- Describes the drive interface.
- Functional Description -- Explains the basic function of the drive.
- Physical Description -- Describes the physical characteristics of the drive.
- Equipment Configuration -- Describes the various drive configurations and how to identify them.

INTERFACE DESCRIPTION

The drive includes a controller that communicates with the initiator or controller adapter (CA) using the Small Computer System Interface (SCSI). Section 3 of this manual lists the signals on the SCSI cables. The SCSI signals and communication protocol are described in detail in the SCSI specification (document number 64721701).

FUNCTIONAL DESCRIPTION

The drive contains all the circuits and mechanical devices required to record data on and recover it from its disks. DC power for the various drive circuits is provided by the power supply, which receives its input power from the site main power source.

TABLE 1-1. DRIVE SPECIFICATIONS

Characteristics	Conditions	Specifications
Size	Dimensions	See Space Requirements in section 3
	Weight (Drive only)	13.0 kg (28.8 lb)
Interface	Weight (Power Supply only)	3.6 kg (8.0 lb)
	Type Transfer Rate	SCSI Up to 4.0 MB/s max
Recording	Unformatted Capacity	
	PA8B1	368 megabytes
	PA8E1	500 megabytes
	Formatted Capacity	
	368 MB drives	
	256-byte sectors	275 914 240
	512-byte sectors	316 216 320
	500 MB drives	
	256-byte sectors	327 260 160
	512-byte sectors	427 115 520
Bytes per track		
368 MB drives		
Unformatted	30 240 bytes	
Formatted	22 784 (89 256-byte sectors) 26 112 (51 512-byte sectors)	
Table Continued on Next Page		

TABLE 1-1. DRIVE SPECIFICATIONS (Contd)

Characteristics	Conditions	Specifications
	<p>Bytes per track</p> <p>500 MB drives</p> <p>Unformatted</p> <p>Formatted</p> <p>Number of disks</p> <p>Movable data heads</p> <p>Servo Heads</p> <p>Tracks per inch</p> <p>Physical heads per surface</p> <p>Logical cylinders per head/disk assy</p> <p>User Cylinders</p> <p>Spare Cylinders</p> <p>Diag. Cylinders</p> <p>System Cylinders</p> <p>Spare Sectors</p> <p>Modulation</p>	<p>Contd</p> <p>41 088 bytes</p> <p>31 232 (106 256-byte sectors)</p> <p>35 840 (69 512-byte sectors)</p> <p>7</p> <p>10</p> <p>1</p> <p>960</p> <p>1</p> <p>1217 (0-1216)</p> <p>1211 (368 MB drives)</p> <p>1209 (500 MB drives)</p> <p>3 (368 MB drives)</p> <p>5 (500 MB drives)</p> <p>1</p> <p>2</p> <p>1 per track (default)</p> <p>(programmable 0 - 3)</p> <p>2-7 code</p>
<p>Table Continued on Next Page</p>		

All operations performed by the drive are related to data storage and recovery (normally referred to as writing and reading). Reading and writing are performed by electromagnetic devices called heads that are positioned over the recording surfaces of the rotating disks. One head is provided for each disk surface. The heads are positioned such that data is written in concentric tracks around the disk surfaces as shown in figure 1-1.

Before a read or write operation can be performed, the controller must instruct the drive to position the heads over the desired cylinder (called seeking) and also to use the head located over the surface (head selection) where the operation is to be performed.

After selecting a head and arriving at the data track, the controller locates the portion of the track on which the data is to be written or read. This is called track orientation and is done by using the Index and Sector signals generated by the drive. The Index signal indicates the logical beginning of each track, and the Sector signals are used by the controller to determine the position of the head on the track with respect to Index.

When the desired location is reached, the controller commands the drive to read or write the data. During a read operation, the drive recovers data from the disks and transmits it to the controller. During a write operation, the drive receives data from the controller, processes it, and writes it on the disks.

The drive is also capable of recognizing certain errors that may occur during its operation. When an error is detected, it is indicated across the SCSI or by a maintenance indicator on the drive itself.

PHYSICAL DESCRIPTION

The components mentioned in the following physical description are shown in figure 1-2.

A drive installation requires a drive, interconnecting cabling, and a power supply. Site power enters the power supply via the ac power cable. The power supply develops the dc voltages required by the drive. These voltages are supplied to the drive by the dc power cable.

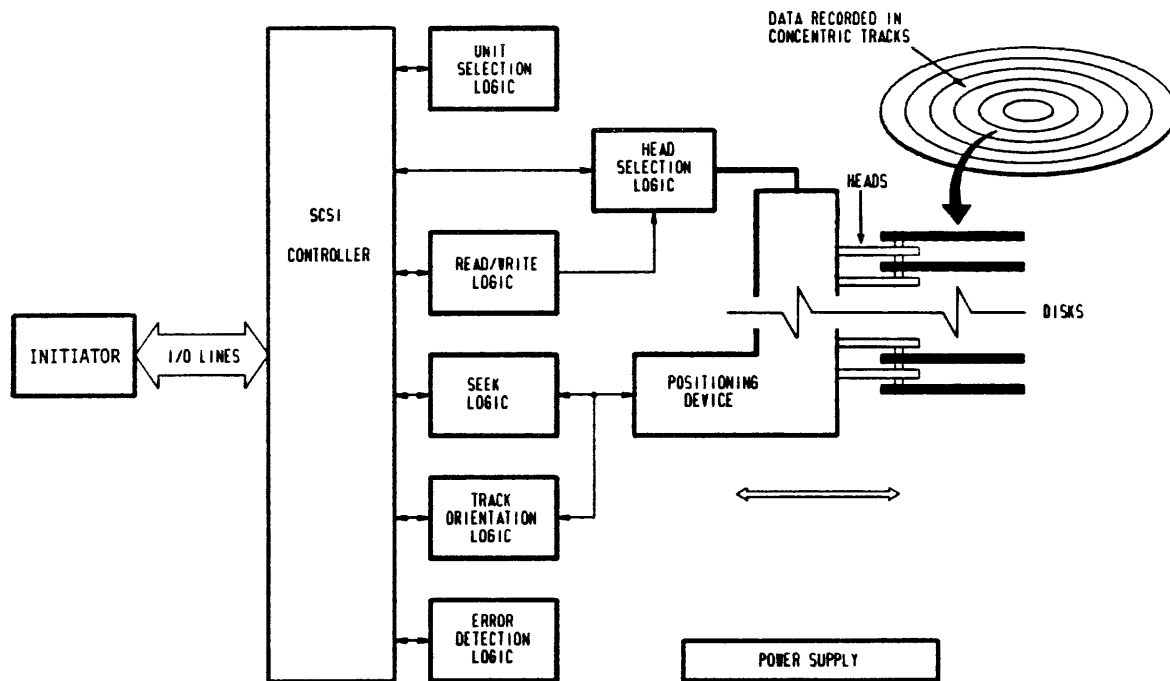

11F135A

Figure 1-1. Drive Functional Block Diagram

The drive includes a top cover, rear panel, module, and four circuit boards. Air flow is provided by a cooling fan. The cooling fan is an integral part of the optional power supply. It provides cooling air to the drive when the power supply is mounted directly in front of the drive. Drive cooling is provided by an optional fan and rear panel assembly when the power supply is mounted in a remote location.

Two optional panels provide external control of the drive. The operator panel contains basic switches and indicators for the operator. The status/control panel contains these same switches and indicators and, for troubleshooting, a diagnostic keyboard and display. These panels can be mounted either inline with the drive and power supply or in a remote location.

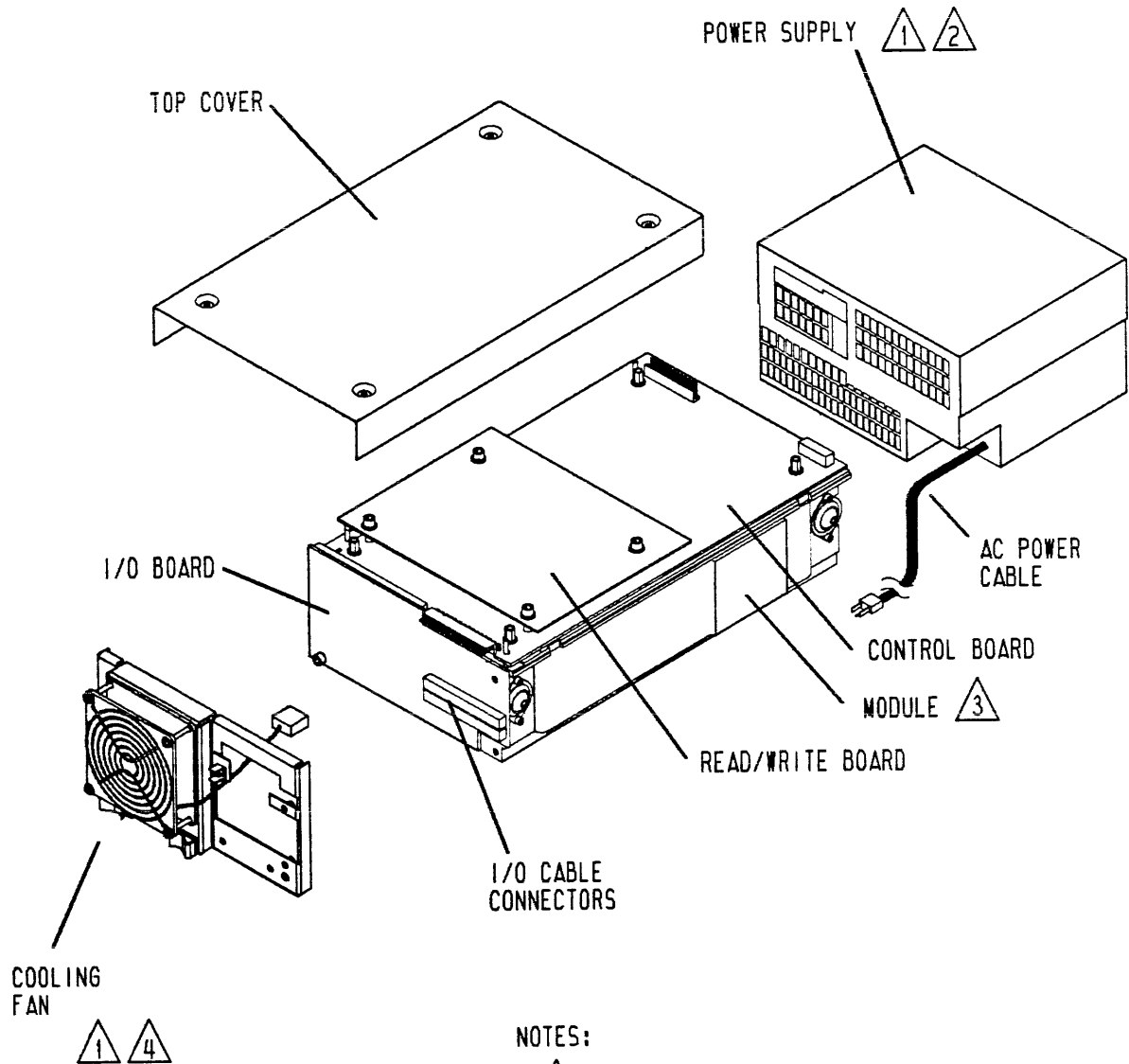

NOTES:

- 1 OPTIONAL
- 2 MOUNTED DIRECTLY IN FRONT OF DRIVE (IN 2X DRAWER) OR MOUNTED IN REMOTE LOCATION
- 3 MODULE CONTAINS THE DISKS, SPINDLE, DRIVE MOTOR, ACTUATOR, AND THE HEADS.
- 4 USED WHEN POWER SUPPLY IS MOUNTED IN REMOTE LOCATION.

11F136

Figure 1-2. Drive Major Assemblies (Sheet 1 of 2)

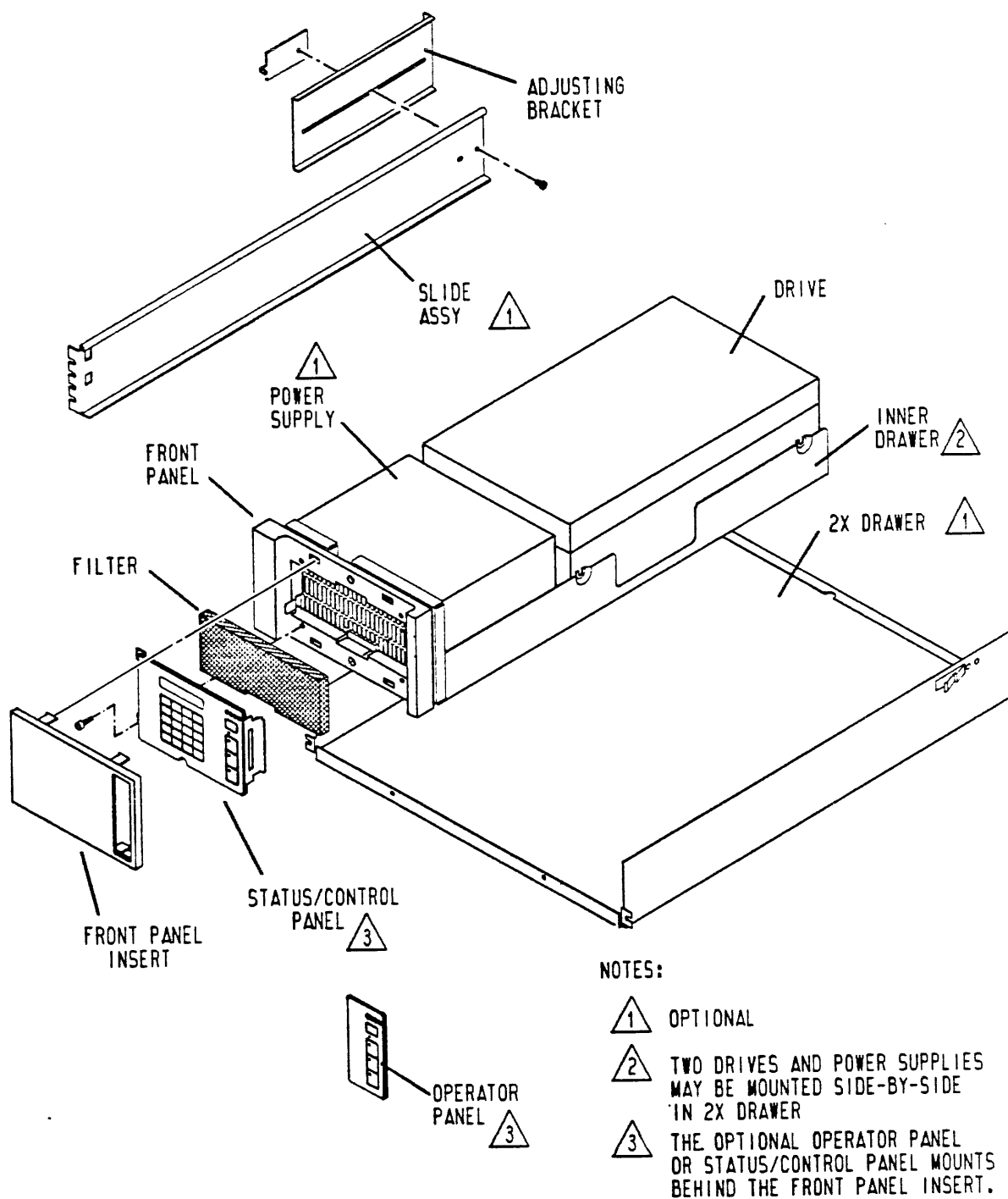

11F62B

Figure 1-2. Drive Major Assemblies (Sheet 2)

The internal components of the drive include three circuit boards and a module. The circuit boards are mounted on the module and they contain the electronics required for drive operation. The module is a sealed unit housing the electromechanical components used for data storage and retrieval. These components include the disks, spindle, drive motor, actuator, and heads.

Seven disks are provided in drive. They are mounted on a spindle that is coupled directly to the drive motor. In operation, the drive motor rotates the disks at 3600 r/min. Rotation of the disks causes circulation of air within the sealed module.

The actuator assembly holds the heads and moves them over the rotating disks. There are 10 data heads for data transfers to and from the disk and one servo head that senses actuator position. The actuator has a voice coil that operates within a permanent magnetic field in response to signals from the servo positioning circuitry. The voice coil moves the heads in an arc across the rotating disks. The heads rest in a preassigned landing zone on the disk surface (beyond the data zone) when the drive is not in use. The actuator automatically latches in this position at shutdown and for moving or shipping protection. The heads fly on a cushion of air close to the disk surface during operation.

The drive can be mounted in either a cabinet or a rack. An optional 2X drawer with a front panel for each drive is available for mounting two drives and power supplies side-by-side.

A complete listing of field-replaceable parts is given in the parts data section (section 4) of this manual. Volume 2 of the hardware maintenance manual contains theory of operation for the drive.

EQUIPMENT CONFIGURATION

GENERAL

The equipment configuration is identified by the equipment identification label and by the Equipment Configuration Log. It is necessary to identify the equipment configuration to determine if the manuals being used are applicable to the equipment. The equipment identification label, Equipment Configuration Log, and Manual To Equipment Level Correlation Sheet are described below.

EQUIPMENT IDENTIFICATION

General

The equipment is identified by labels attached to the drive top cover and to the power supply. The label on the drive top cover identifies the basic mechanical and logical configuration of the drive at the time it left the factory. Always install the top cover on the drive from which it was removed to ensure accurate drive configuration information is maintained. The label on the power supply references the components making up the drive installation and lists the site power requirements for the power supply.

Equipment Identification Number

The equipment identification number is divided into the two parts shown in the example:

EXAMPLE:

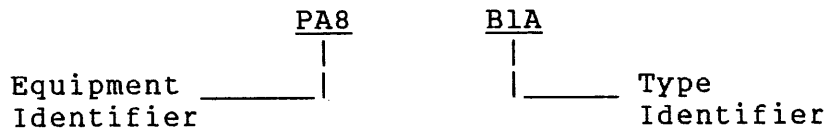

The equipment identifier indicates the basic functional capabilities of the drive.

The type identifier indicates differences between drives that have the same equipment identifier. These differences are necessary to adapt a drive to specific system requirements. However, they do not change the overall capabilities of the drive as defined in table 1-1.

Series Code

The series code represents a time period in which the unit was built. All units are interchangeable at the system level, regardless of series code; however, parts differences may exist in units with different series codes. When a parts difference exists, that difference is noted in the parts data section of this manual.

Part Number

The equipment identification label on the power supply lists three numbers: the equipment package part number, the Complete Drive Assembly (CDA) number, and the power supply number. The equipment package part number is the number assigned to the complete unit including drive, power supply (if applicable), painted panels, installation hardware, etc. The power supply number is the part number for the power supply only.

Serial Number

Each drive has a unique serial number assigned to it. Serial numbers are assigned sequentially within a family of drives. No two drives have the same serial number.

EQUIPMENT CONFIGURATION LOG

Engineering Change Orders (ECOs) are drive electrical or mechanical changes made at the factory and may cause a series code change. When the factory installs an ECO early (prior to a series code change), it is noted on the configuration log.

Field Change Orders (FCOs) are electrical or mechanical changes that can be installed in the drive either at the factory or in the field. FCO changes do not affect the series code but are indicated by an entry on the Equipment Configuration Log that accompanies each drive. The components of a drive with an FCO installed may not be interchangeable with those of a drive without the FCO. It is important that the Equipment Configuration Log be kept current by the person installing the FCO.

MANUAL TO EQUIPMENT LEVEL CORRELATION

Throughout the life cycle of the drive, changes are made either at the factory (a series code change) or by FCOs installed in the field. These changes are reflected in changes to the manuals for the drive. To ensure the manual correlates with the drive, refer to the manual to equipment level correlation sheet located in the front matter of this manual. This sheet records all the FCOs which are reflected in the manual. It should correlate with the Equipment Configuration Log for the drive if all the FCOs have been installed.

SECTION 2

OPERATION

INTRODUCTION

This section explains how to operate the drive. It is arranged as follows:

- Switches and Indicators -- describes the switches and indicators used for normal drive operation.
- Starting The Drive -- describes how to start the drive.
- Stopping The Drive -- describes how to stop the drive.
- Filter Replacement and Cleaning -- describes how to remove, clean, and install the air filter.

SWITCHES AND INDICATORS

The only Switches and indicators normally used by the operator are on the optional operator panel or status/control panel. Figure 2-1 shows these switches and indicators, and they are described in table 2-1. Refer to section 3 and to appendix A for information on switches that are not normally used by the drive operator.

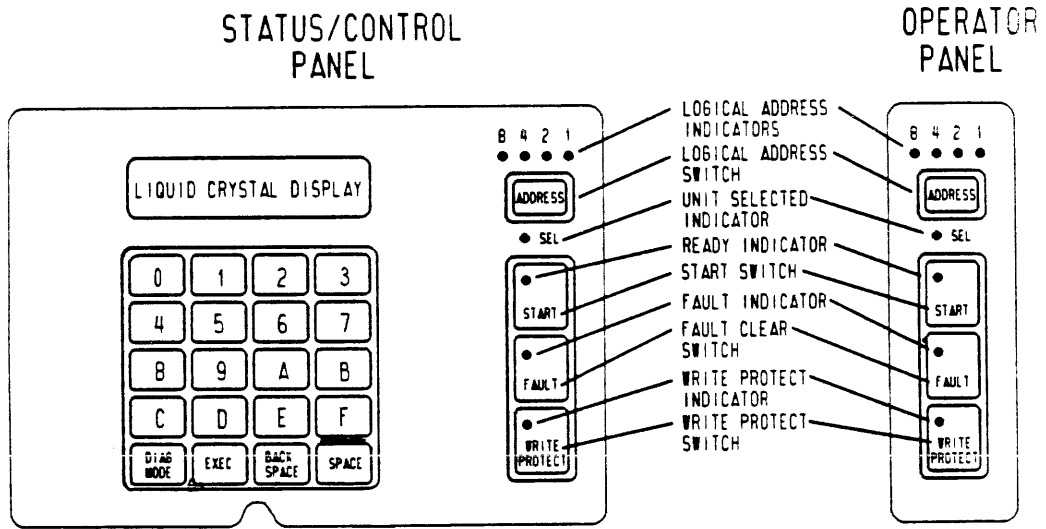
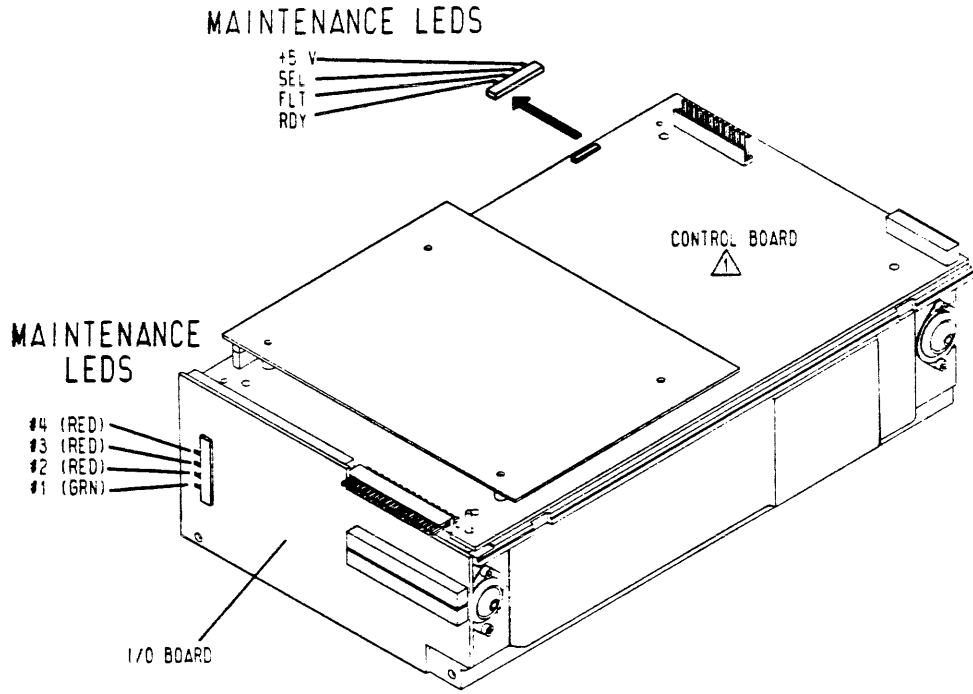

NOTE:
 ▲ SWITCHES LOCATED ON CIRCUIT BOARDS ARE EXPLAINED IN SECTION 3

11F215

Figure 2-1. Switches and Indicators

TABLE 2-1. OPERATOR PANEL SWITCHES AND INDICATORS

Switch or Indicator	Function
<p>ADDRESS Switch Logical Address Indicators 8/4/2/1</p>	<p>Sets the logical address of the drive. Pressing it for 2 to 3 seconds advances the logical address. Pressing it longer increments the address continuously. The Logical Address Indicators display the logical address in binary. Logical address is stored in memory when dc power is off. This address must always be set to 0 as only address 0 is recognized.</p>
<p>SEL (Selected Indicator)</p>	<p>Indicates the drive is selected.</p>
<p>START Switch/ Ready Indicator</p>	<p>Pressing this momentary switch starts power on sequence and Ready indicator flashes (rapidly) until disks are up to speed, heads are loaded, and no fault conditions exist. The Ready indicator is on steady when power on sequence is complete. Pressing the switch again releases it from Start causing Ready indicator to flash (slowly) until disk rotation has stopped. The current condition of the START switch (Start/Stop) is stored in memory when dc power is removed.</p>
<p>FAULT Indicator/ Fault Clear Switch</p>	<p>The FAULT indicator is inside the Fault Clear switch, and it lights if a fault exists within the drive. It is turned off by any of the following (provided no error conditions exist):</p> <ul style="list-style-type: none"> • Pressing the Fault Clear switch • Fault Clear command from the controller • A drive power on operation
<p>Table Continued on Next Page</p>	

TABLE 2-1. OPERATOR PANEL SWITCHES AND INDICATORS (Contd)

Switch or Indicator	Function
WRITE PROTECT Switch/Indicator	Places the drive in the write protected mode (preventing write operations) and lights the WRITE PROTECT indicator. Current switch position is stored in memory when dc power is off.

STARTING THE DRIVE (DRIVES WITH OPERATOR PANEL)

1. Check the Logical Address Indicators. All indicators must be off (logical address 0). If any indicators are on, press and hold the ADDRESS switch until all indicators are off.
2. Press the START switch.
 - If the Power On Sequence switch (DIP switch 3) on the I/O board was set to its off (open) position at the time of installation, the power on sequence continues, but actual starting of the drive is delayed in increments of five seconds depending on the Target ID assigned to it.

For example:

 Target ID 0 = 0 second delay
 Target ID 1 = 5 second delay
 Target ID 7 = 35 second delay
 - If the Power On Sequence switch (DIP switch 3) on the I/O board was set to the on (closed) position at the time of installation, the drive starts immediately when the START switch is pressed.
3. Observe that the Ready indicator (in the START switch) flashes rapidly indicating the power on sequence is in progress.
4. Observe that the Ready indicator lights steadily within 90 seconds. This indicates the disks are up to speed and the heads are loaded.
5. Observe that the FAULT indicator is off. This indicates the drive is ready to read and write data.

STOPPING THE DRIVE (DRIVES WITH OPERATOR PANEL)

1. Press the START switch.
2. Observe that the Ready indicator (in the START switch) flashes slowly, indicating that the stop sequence is in progress.
3. Observe that the Ready indicator turns off within 60 seconds, indicating that the stop sequence is complete.

OPERATING DRIVES WITH NO OPERATOR PANEL

The start sequence begins when the On/Standby switch on the power supply is placed in the On (1) position. The start sequence continues in one of the following manners depending on how the Power On Sequence switch (DIP switch 3) on the I/O board was set at the time of drive installation.

- If the Power On Sequence switch (DIP switch 3) on the I/O board was set to the off (open) position at the time of drive installation, the start sequence is delayed in increments of five seconds depending on the Target ID assigned to the drive.

For example:

Target ID 0 = 0 second delay
Target ID 1 = 5 second delay
Target ID 7 = 35 second delay

- If the Power On Sequence switch (DIP switch 3) was set to the on (closed) position, each drive starts immediately when the power supply On/Standby switch is placed in the On position.

The drive can be stopped using the Start/Stop Unit command, or by placing the On/Standby switch in the Standby position.

REPLACING OR CLEANING THE AIR FILTER

The air filter must be clean to ensure proper air circulation through the drive. The filter is located behind the operator panel or status/control panel as shown in figure 2-2. Inspect the filter frequently and replace it when it is dirty. Clean the filter only if a replacement filter is not available. The procedure for replacing the air filter is simple.

1. Remove front panel insert from drive (see figure 2-2).

CAUTION

Be careful not to damage the system cabling when sliding the drive in the drawer and the drawer in and out of the rack.

NOTE

The release latch on the left drive locks the 2X drawer into the rack. The release latch on the right drive has no function.

2. Push 2X drawer release latch to the right and extend 2X drawer to gain access to power supply.
3. Remove power from drive as follows:
 - If drive does not have an operator panel, place On/Standby switch on power supply in Standby (0) position (see figure 2-3).
 - If drive has an operator panel, press START switch. Wait for Ready indicator to stop flashing and then place On/Standby switch on power supply in Standby (0) position.
4. If status/control panel is installed, remove two screws that secure it to front panel (see figure 2-3). Move panel away from front panel.

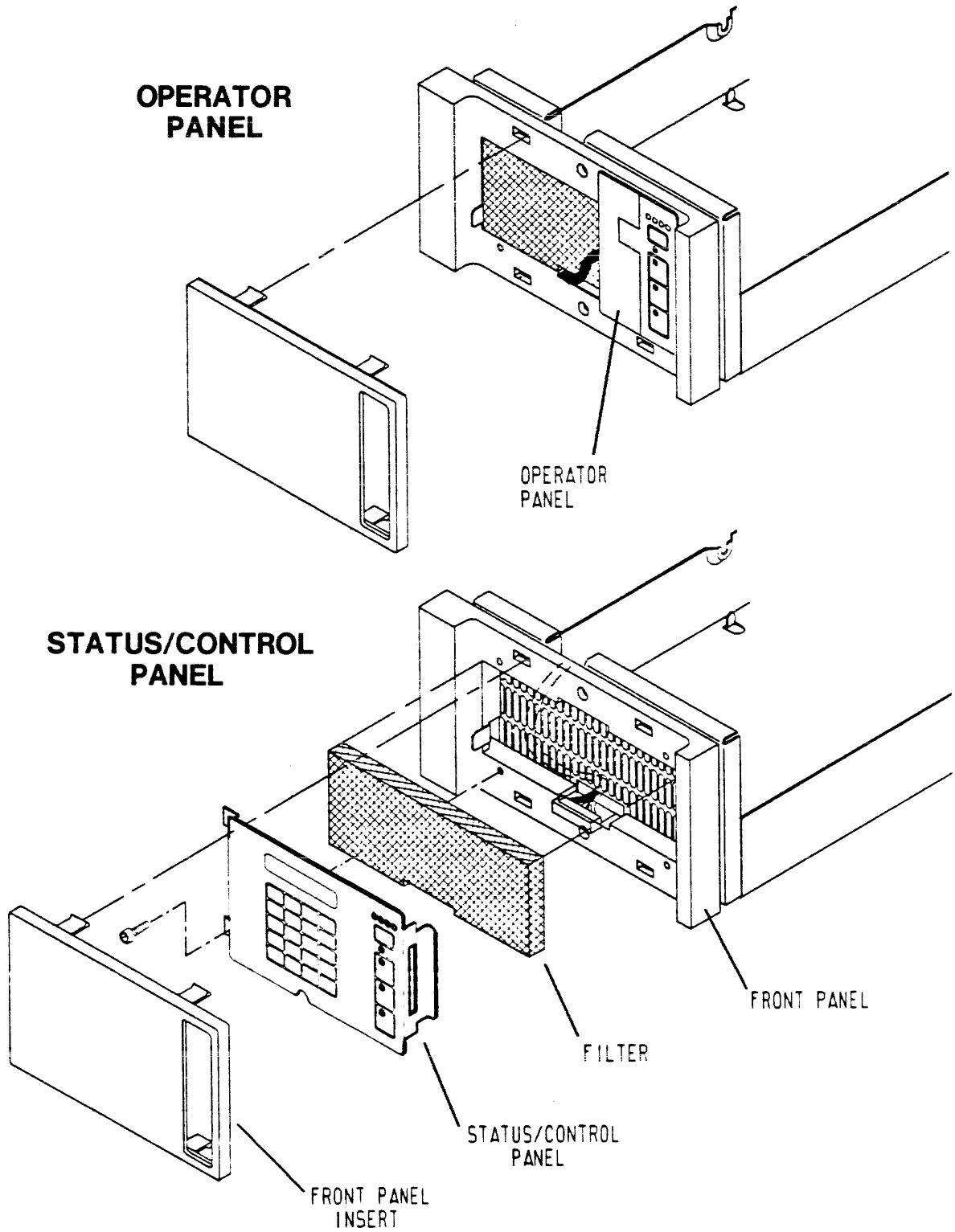

11F129A

Figure 2-2. Air Filter Replacement

5. Remove dirty filter. If replacement filter is not available, clean dirty filter in solution of water and mild detergent. Rinse filter and allow it to dry.
6. Install clean filter.
7. If used, align status/control panel with front panel and secure it with mounting screws.
8. Place On/Standby switch on power supply in On (1) position.
9. Push 2X drawer to closed position in rack.
10. Install front panel insert.

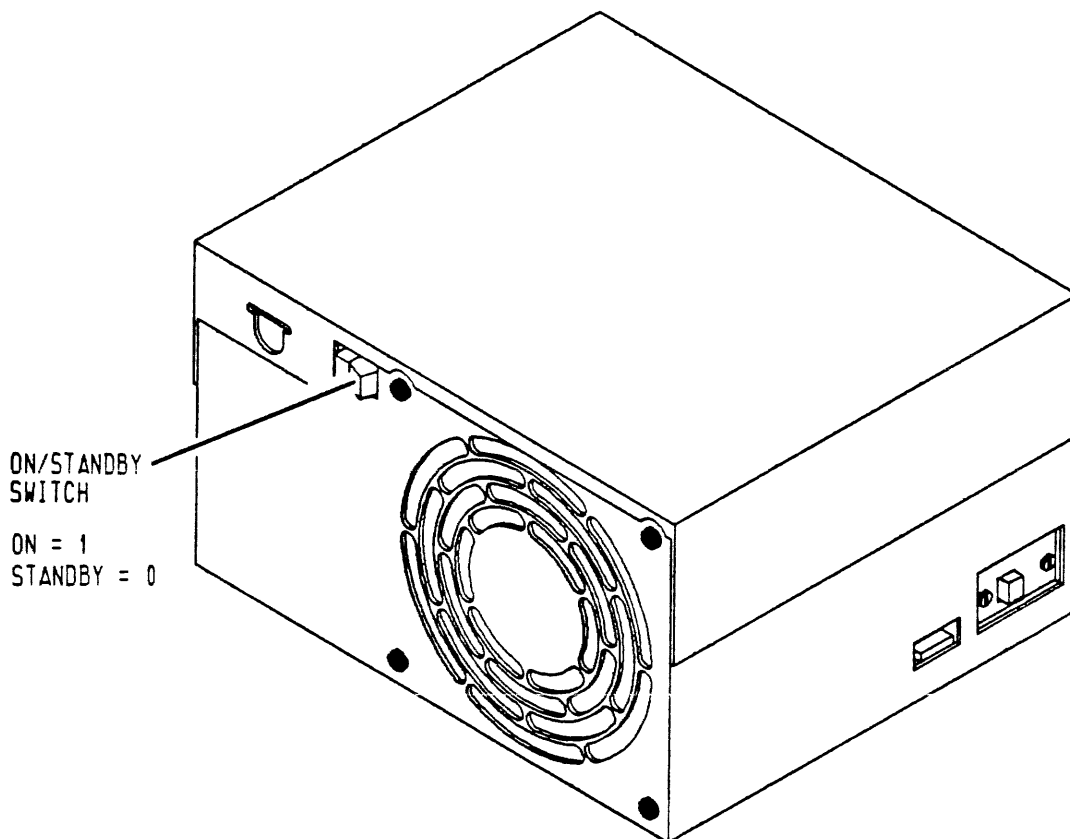

iiF2i6

Figure 2-3. Power Supply On/Standby Switch

SECTION 3

INSTALLATION AND CHECKOUT

INTRODUCTION

The information contained in this section describes installation and initial checkout of the drive.

SITE REQUIREMENTS

The site requirements considered are electrostatic discharge protection, environment, space, power, grounding, and interface.

ELECTROSTATIC DISCHARGE PROTECTION

All drive electronic assemblies are sensitive to static electricity, due to the electrostatically sensitive devices used within the drive circuitry. Although some of these devices such as metal-oxide semiconductors are extremely sensitive, all semiconductors as well as some resistors and capacitors may be damaged or degraded by exposure to static electricity.

Electrostatic damage to electronic devices may be caused by a direct discharge of a charged conductor, or by exposure to the static fields which surround charged objects. To avoid damage to drive electronic assemblies, service personnel must observe the following precautions when servicing the drive:

- Ground yourself to the drive whenever the drive electronics are or will be exposed. Connect yourself to ground with a wrist strap (refer to Accessories in section 4 for part numbers). Connection may be made to any metal assembly. As a general rule, remember that you, the drive, and the circuit boards must all be at ground potential to avoid potentially damaging static discharges.
- Keep boards in conductive bags. When circuit boards are not installed in the drive, keep them in conductive static shielding bags (refer to Accessories in section 4 for part numbers). These bags provide absolute protection from direct static discharge and from static fields surrounding charged objects. Remember that these bags are conductive and should not be placed where they might cause an electrical short circuit.

- Remove boards from bags only when you are grounded. All boards received from the factory are in static shielding bags, and should not be removed unless you are grounded.
- Turn off power to the drive before removing or installing circuit boards.
- Do not touch pins on power supply connector J15. The power supply circuitry is sensitive to electrostatic discharge.
- Never use an ohmmeter on any circuit boards.

ENVIRONMENTAL REQUIREMENTS

All environmental requirements for the drive are listed in table 3-1.

TABLE 3-1. ENVIRONMENTAL REQUIREMENTS

Conditions	Characteristics	Specifications
TEMPERATURE		
Storage (Packaged)	Range	-10°C to 50°C (14°F to 122°F)
	Maximum change per hr	15°C (27°F)
Transit (Packaged)	Range	-40°C to 60°C (-40°F to 140°F)
	Maximum change per hr	20°C (36°F)
Operating	Range	10°C to 45°C (50°F to 113°F)
	Maximum change per hr	15°C (27°F)
Table Continued on Next Page		

TABLE 3-1. ENVIRONMENTAL REQUIREMENTS (Contd)

Conditions	Characteristics	Specifications
RELATIVE HUMIDITY		
Storage (Packaged)	Range	5% to 95%
Transit (Packaged)	Range	5% to 95%
Operating	Range	20% to 80% (No condensation allowed)
BAROMETRIC PRESSURE (STANDARD DAY)		
Storage (Packaged)	Range	-305 m to 3000 m (-1000 to 10 000 ft) 104 kPa to 69 kPa (30 in to 20 in Hg)
Transit (Packaged)	Range	-305 m to 12 192 m (-1000 to 40 000 ft) 104 kPa to 19 kPa (30 in Hg to 6 in Hg)
Operating	Range	-305 m to 3000 m (-1000 to 10 000 ft) 104 kPa to 69 kPa (30 in Hg to 20 in Hg)

SPACE REQUIREMENTS

The drive and power supply mount side-by-side with another drive and power supply into a 2X drawer. The 2X drawer slide mounts into a 483 mm (19 in) standard rack. The slides allow outward extension of the drawer for ease of maintenance. Space requirements for this and custom-installations are shown in figure 3-1.

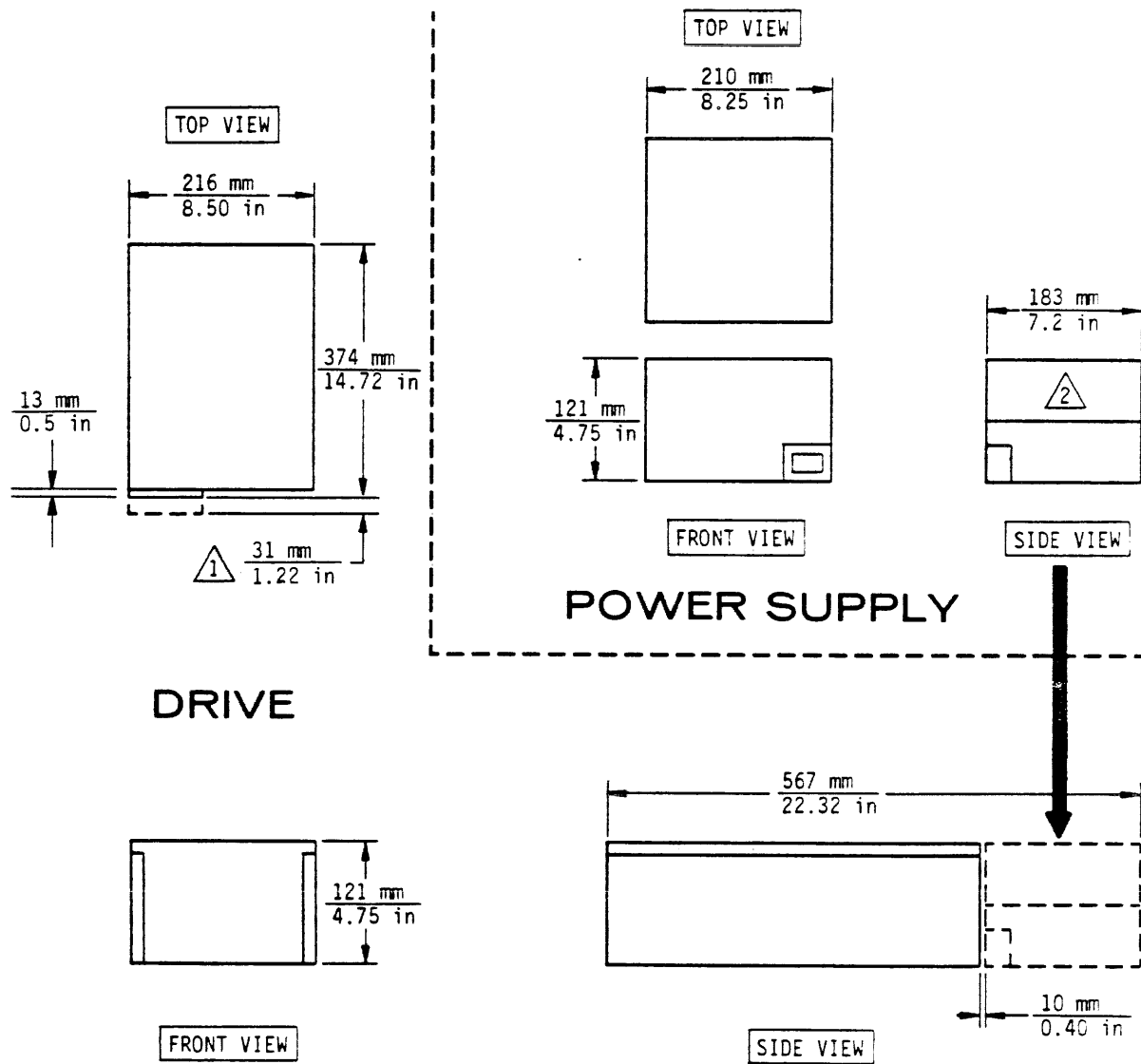

NOTES:

- ① COOLING FAN MOUNTS ON REAR PANEL WHEN POWER SUPPLY IS NOT MOUNTED IN LINE WITH DRIVE.
- ② COOLING FAN IS INSIDE POWER SUPPLY.
- 3. DIMENSIONS ARE NOMINAL.

IIF137A

Figure 3-1. Drive Space Requirements

The combined mass of the drive and power supply is 16.6 kg (36.8 lb). With both units mounted in the drawer and the drawer extended on the slides, the center of gravity is approximately 32 cm (12.5 in) from the front of the rack.

POWER REQUIREMENTS



WARNING

This unit has a single phase power supply with a capacitor input filter (sometimes called a switching type supply). If power comes from a 3-phase, 4-wire, wye branch or feeder circuit, ensure the circuit meets the latest requirements of the United States National Electrical Code. Failure to meet these requirements may cause hazardous conditions due to high currents and heating in the neutral conductors and transformers supplying the unit.

Drive ac power requirements are listed in table 3-2. Conversion to the different line voltages is explained in the installation procedures. Typical drive current versus start-up time is shown in figure 3-2 for 100-120 and 208-240 volt connections.

GROUNDING REQUIREMENTS

Two grounding schemes are used to ensure safe and reliable operation of the drive. Safety grounding consists of connecting the drive power cord to a grounded outlet. System grounding establishes a common ground between the drives, the power supplies, and the host. Safety and system grounding are described below.

Safety Grounding

A safety ground must be provided by the site ac power system. The green wire (or green wire with yellow stripe) in the drive power cord provides the safety ground connection between the power supply and the site ac power system. The site ac power system must tie this connection (safety ground) to earth ground. All site ac power connection points, including convenience outlets for test equipment, must be maintained at the same safety ground potential.

System Grounding

Grounding the system through the power cables and I/O cables is usually sufficient to protect against noise and emissions. If additional protection is required, the following instructions are recommended for grounding the system.

System grounding is established with ground straps connected in a daisy chain configuration. The ground straps connect the system ground point on the host to earth ground and to each drive in the system. The installation procedures in this section provide a schematic diagram and system grounding instructions.

TABLE 3-2. POWER REQUIREMENTS

Specifications	Nominal Values	
	100 - 120 V ac	208 - 240 V ac
Voltage Range	85 to 132 V	177 to 264 V
Nominal Line Frequency	50/60 Hz	50/60 Hz
Frequency Range	48.0 to 62.0 Hz	48.0 to 62.0 Hz
Phase Requirements	Single Phase	Single Phase
Power Consumed*	0.145 - 0.150 kW	0.145kW
Line Current*	2.4 - 2.2 A	1.4 - 1.2 A
Power Factor*	0.60 - 0.57	0.50
Start Up Current	See figure 3-2	See figure 3-2
*Approximate values with disks rotating and carriage moving.		

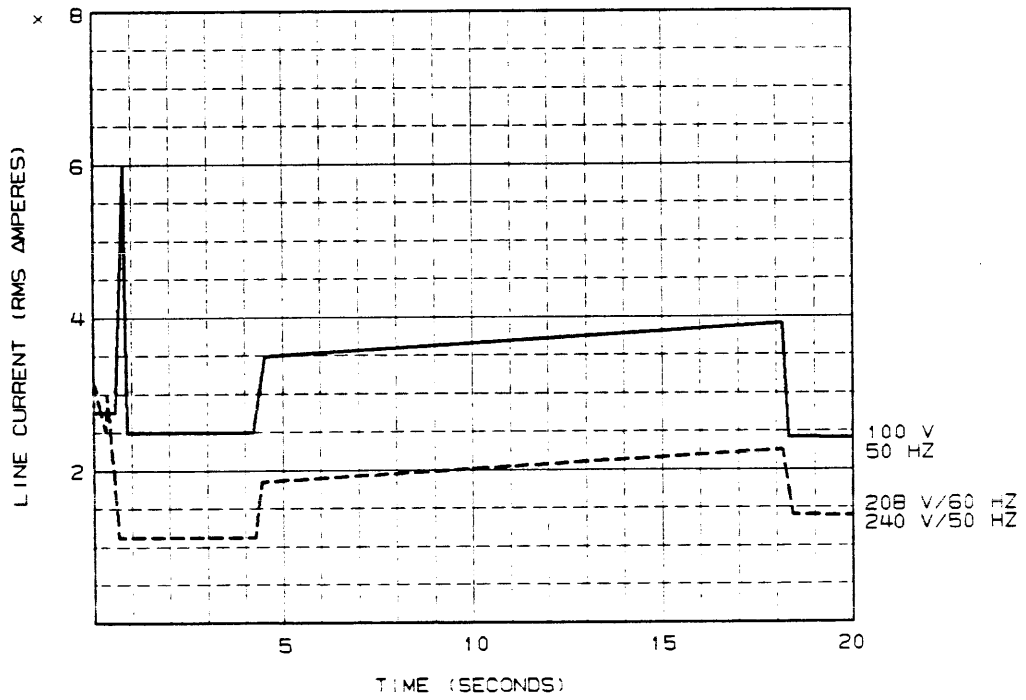
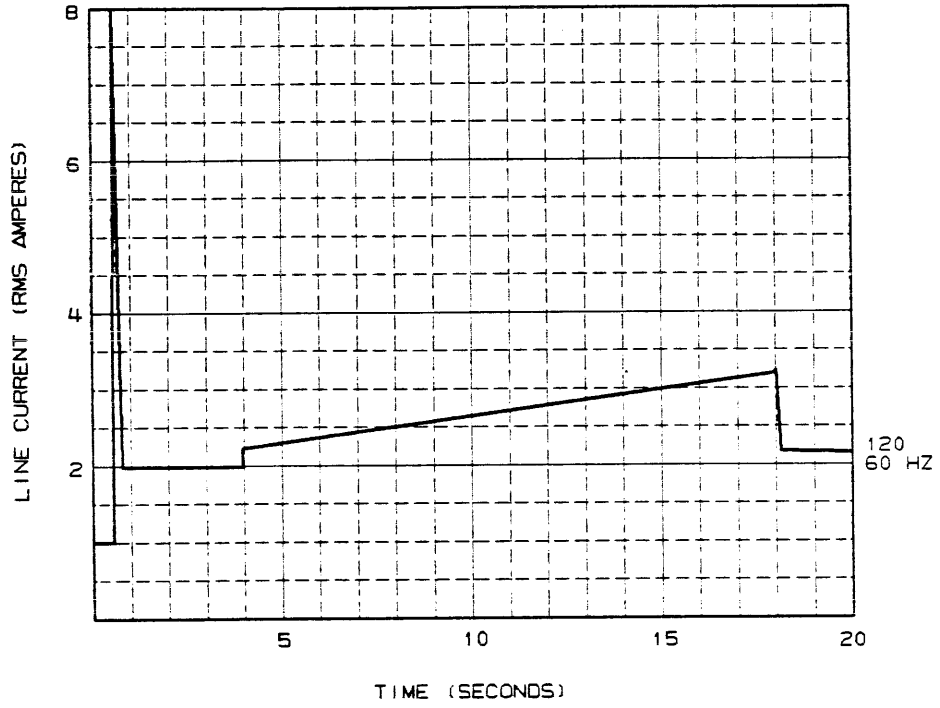

11F214

Figure 3-2. Typical Line Current Versus Start-up Time

INTERFACE REQUIREMENTS

An important part of site preparation is planning the layout and routing of I/O cables. The I/O cables are connected in a daisy chain configuration as shown in figure 3-3. A terminator is required on the host and on the last drive in the string.

In a daisy chain configuration an I/O cable connects the host to the first drive in the string. A second I/O cable connects the other connector on the first drive to one of the I/O connectors on the second drive. This process continues until all drives are connected. A terminator is installed in the last drive in the string. Allow sufficient length to permit full extension of rack-mounted drives when determining I/O cable needs. Limitations on I/O cable lengths may influence system layout.

The cumulative cabling in a daisy chain system cannot exceed 25.0 m (82.5 ft) in length if using differential I/O, or 6.0 m (19.8 ft) if using single ended I/O. Refer to Accessories in section 4 for terminator and I/O cable part numbers.

Table 3-3 shows the pin assignments and signal names for the single ended I/O cable. Table 3-4 shows the pin assignments and signal names for the differential I/O cable.

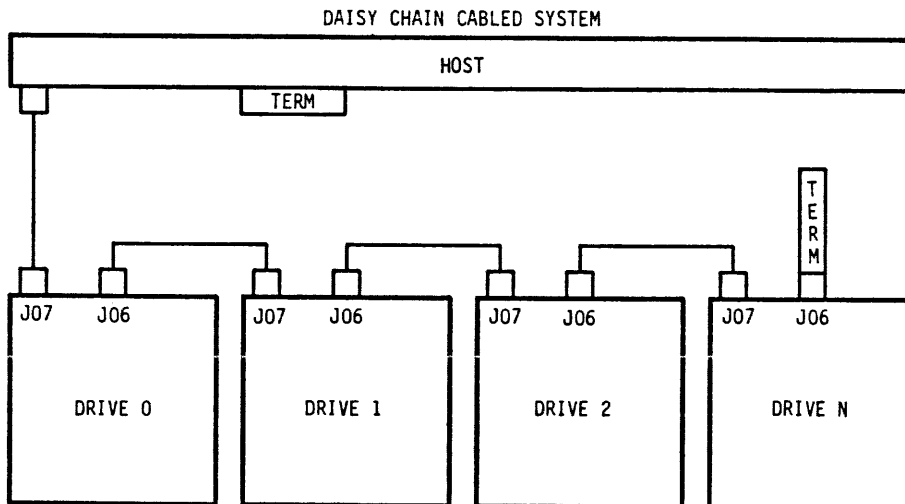

NOTES:

1. MAXIMUM INDIVIDUAL CABLE LENGTHS = 6.0 M (19.8 FT)
2. MAXIMUM CUMULATIVE CABLE LENGTHS = 25 M (82.5 FT)
3. A SYSTEM MAY INCLUDE UP TO 7 DRIVES (8 SCSI DEVICES)

11F138A

Figure 3-3. System I/O Cabling

TABLE 3-3. SINGLE ENDED CABLE PIN ASSIGNMENTS

Signal Name	Unshielded Cable Pin Number	Shielded Cable Pin Number
-DB(0)	2	26
-DB(1)	4	27
-DB(2)	6	28
-DB(3)	8	29
-DB(4)	10	30
-DB(5)	12	31
-DB(6)	14	32
-DB(7)	16	33
-DB(P)	18	34
GROUND	20	35
GROUND	22	36
GROUND	24	37
TERMPWR	26	38
GROUND	28	39
GROUND	30	40
-ATN	32	41
GROUND	34	42
-BSY	36	43
-ACK	38	44
-RST	40	45
-MSG	42	46
-SEL	44	47
-C/D	46	48
-REQ	48	49
-I/O	50	50
Minus (-) sign indicates active low.	All odd pins except 25 must be connected to ground.	Pins 1 through 12 and 14 through 25 connect to ground. Pin 13 is open.

TABLE 3-4. DIFFERENTIAL CABLE PIN ASSIGNMENTS

Signal Name	Unshielded Cable Pin Number	Shielded Cable Pin Number
SHIELD (GROUND)	1	1
GROUND	2	26
+DB(0)	3	2
-DB(0)	4	27
+DB(1)	5	3
-DB(1)	6	28
+DB(2)	7	4
-DB(2)	8	29
+DB(3)	9	5
-DB(3)	10	30
+DB(4)	11	6
-DB(4)	12	31
+DB(5)	13	7
-DB(5)	14	32
+DB(6)	15	8
-DB(6)	16	33
+DB(7)	17	9
-DB(7)	18	34
+DB(P)	19	10
-DB(P)	20	35
DIFFSENS	21	11
GROUND	22	36
GROUND	23	12
GROUND	24	37
TERMPWR	25	13
TERMPWR	26	38
GROUND	27	14

Table Continued on Next Page

TABLE 3-4. DIFFERENTIAL CABLE PIN ASSIGNMENTS (Contd)

Signal Name	Unshielded Cable Pin Number	Shielded Cable Pin Number
GROUND	28	39
+ATN	29	14
-ATN	30	40
GROUND	31	16
GROUND	32	41
+BSY	33	17
-BSY	34	42
+ACK	35	18
-ACK	36	43
+RST	37	19
-RST	38	44
+MSG	39	20
-MSG	40	45
+SEL	41	21
-SEL	42	46
+C/D	43	22
-C/D	44	47
+REQ	45	23
-REQ	46	48
+I/O	47	24
-I/O	48	49
GROUND	49	25
GROUND	50	50

Shield ground is optional on some cables.

UNPACKING, INSPECTION AND REPACKAGING

Unpack the drive using the unpacking instructions provided with it. Save all packing material for future use. Inspection for shipping damage and several final unpacking procedures must be performed as outlined below.

UNPACKING

1. Open package. Save all packing materials for use if drive must be shipped in the future.
2. If drive has a 2X drawer with slide mount option, remove packages containing drawer, two slide mounts, and slide mount hardware kit.
3. Remove package containing ac and dc power cables.
4. Open sealed vapor barrier bag and remove drive and power supply.
5. Check all items against shipping bill for required equipment and hardware to complete installation. Report discrepancies, missing items, damaged equipment, etc., to the account sales representative responsible for the equipment.

INSPECTION

Inspect the drive, power supply, and accessory items for possible shipping damage. Claims for shipping damage must be filed with the carrier involved.

REPACKING

If it is necessary to ship the drive, pack it using the original packing materials. Comply with the manufacturer's packing instructions to ensure that the drive will be undamaged in shipment. To obtain packing instructions, contact:

Imprimis Technology Incorporated
Customer Services
5950 Clearwater Drive
Minnetonka, MN 55343

Phone: 1-800-382-6060
Fax: (612) 931-8817

When ordering packing instructions, specify the exact equipment number and series code of the drive as shown on the equipment identification label.

INSTALLATION PROCEDURES

GENERAL

With the site requirements completed and the drive unpackaged, you are ready to begin the installation. Certain parts of the installation may vary -- how the drive and power supply are mounted, how dc power is supplied to the drive, if the fan kit is required, and whether an operator panel or status/control panel is used. The following procedures apply to installations where the drive and power supply are mounted in a 2X drawer:

- Mounting 2X Drawer in Rack
- Mounting Front Panel
- Mounting Operator Panel or Status/Control Panel
- Mounting Drive and Power Supply in 2X Drawer

The drive, power supply, and operator panel (if used) can be mounted in an inner drawer prior to shipment. In this case, the following procedures apply:

- Mounting 2X Drawer in Rack
- Mounting Drive and Power Supply in 2X Drawer

The topic Alternate Methods for Installing the Drive provides some basic information for those installations where a 2X drawer is not used. Specific details for alternate mounting are beyond the scope of this manual. The optional fan kit is required only when the power supply is mounted remotely from the drive. It is not required when the drive and power supply are mounted in the 2X drawer.

The following group of procedures applies to all installations.

- System I/O Cabling
- System Grounding
- Setting Circuit Board Switches.

In most cases you will find it convenient to perform the procedures in the order they are presented. However, you might find it convenient to make switch settings on both the drive and the power supply before mounting them.

POWER SUPPLY VOLTAGE CONVERSION

The power supply is set before shipment to operate from one of two ac input voltages (115 V or 230 V). The voltage select plate on the power supply (see figure 3-4) indicates the voltage range selected prior to shipment.

The voltage range is determined by setting the voltage select switch to the desired range. The voltage select plate locks the switch in the desired range. The ac power cord must be replaced if the voltage range is changed. Refer to figure 3-5 and the parts data section for information about ordering the replacement ac power cable.

1. Disconnect ac power cable from power supply.
2. Remove screw securing voltage select plate to power supply. Remove plate and save it and the screw.
3. Set voltage select switch to desired range.
4. Reverse voltage select plate and install it on power supply to lock switch in desired range. Plate must indicate new voltage setting.
5. Install ac power cable specified for selected operating voltage. If long and short power cords are provided, the short cord attaches to the power supply.

MOUNTING 2X DRAWER IN RACK

The slide assemblies permit inline mounting of the 2X drawer in a rack. The drawer may be extended out the front surface of the rack for maintenance. The following procedure describes how to attach the 2X drawer to the rack.

1. Remove screws from rack mounting kit. There are four smaller screws in kit. Two screws attach slide adjusting brackets to slides (step 2). Two others attach inner drawers to 2X drawer (see Mounting Drive and Power Supply in 2X Drawer).
2. Loosely attach a slide adjusting bracket to each slide with a bracket clamp and screw (see figure 3-6).
3. Loosely attach screws and nut plates for each slide to rack. The screws go in top and third holes at front of rack and in top and bottom holes at rear of rack as shown in figure 3-6.
4. Set slide adjusting brackets as required for proper rack depth and mount right and left slides in rack. Orient slides so 2X drawer rests on flat edge of slides as shown in figure 3-6.

5. Secure adjusting brackets to slides and slides to rack.
6. Lift drawer and guide it into slide assemblies. Continue pushing it inward until drawer is in rack. Ensure drawer does not bind when sliding it in and out of rack.

If it is necessary to remove the drawer from the rack, slide the drawer out to full extension. Press the drawer locking springs and remove the drawer from the rack.

NOTES:

 LOCKS VOLTAGE SWITCH IN EITHER 115V POSITION OR 230V POSITION (OTHER SIDE)

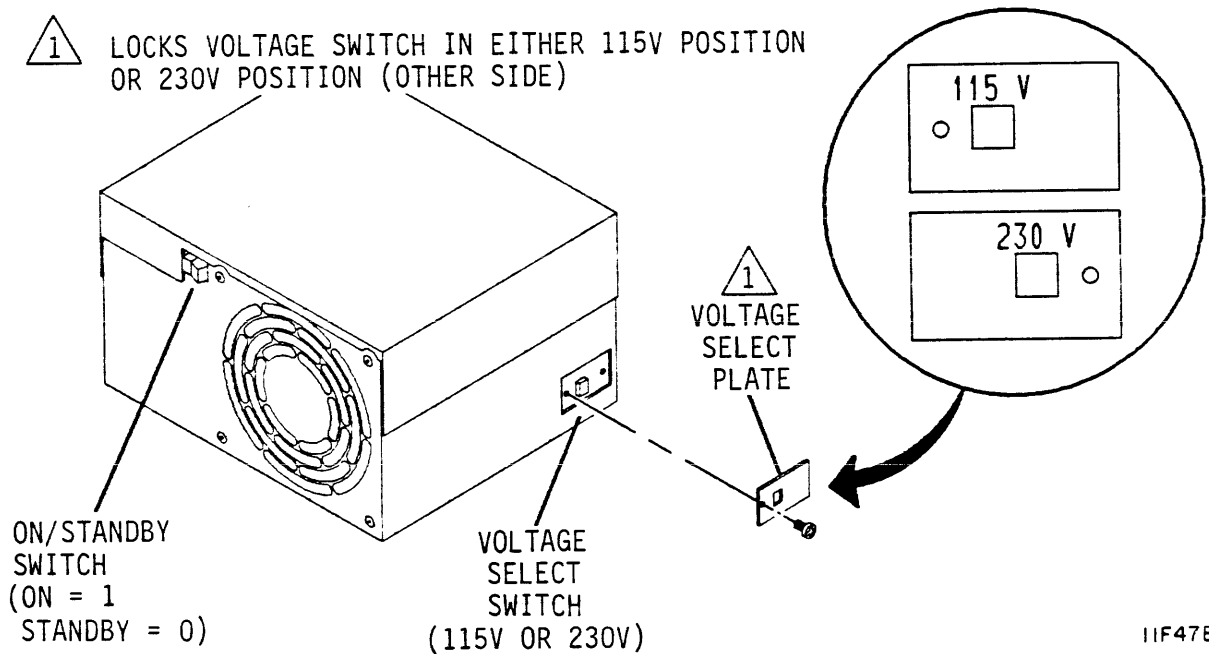

11F47B

Figure 3-4. Power Supply Voltage Conversion

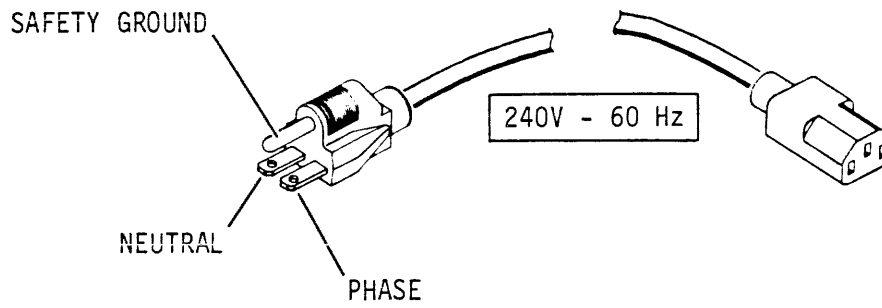
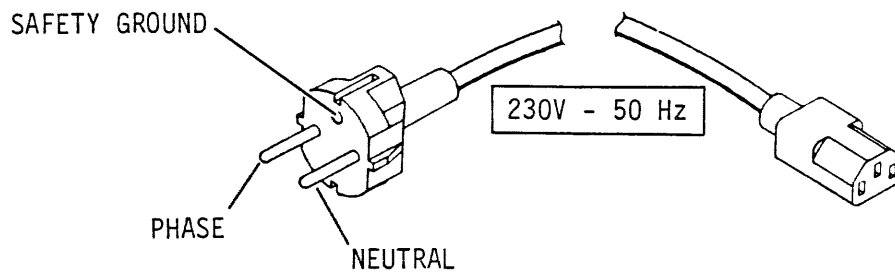
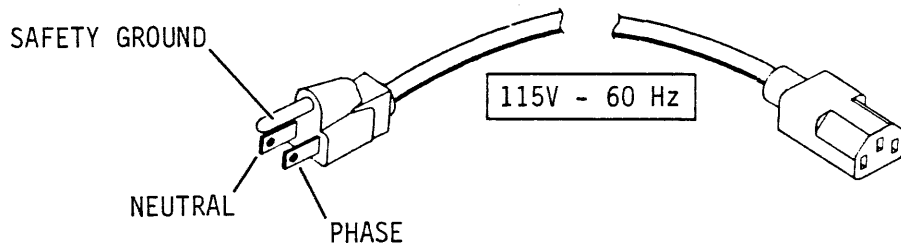

11H94A

Figure 3-5. AC Power Cables

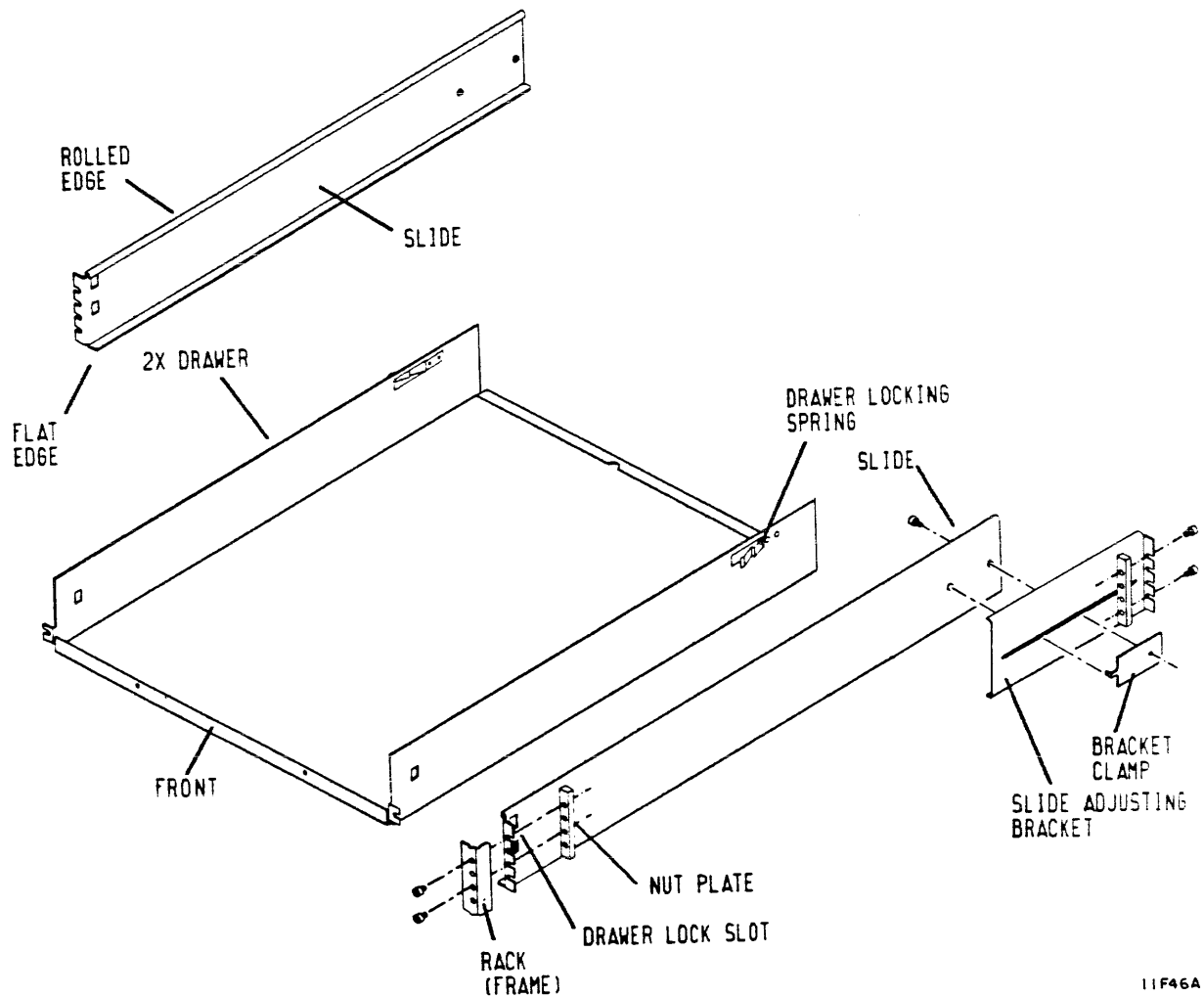

11F46A

Figure 3-6. 2X Drawer Installation

MOUNTING FRONT PANEL

This procedure describes how to install the air filter and how to attach the front panel to the inner drawer. If the optional operator panel or status/control panel will be installed, go to the next procedure which includes front panel mounting instructions.

NOTE

When installing the front panel, ensure the overhang covers the rack frame (vertical support). If the left and right inner drawers are interchanged in the 2X drawer, rotate the front panels 180 degrees.

1. Align top edge of front panel with top edge of inner drawer (see figure 3-7).
2. Secure front panel in place with four screws.
3. Install air filter.
4. Remove adhesive backing from filler plate and attach it to front panel insert.
5. Install front panel insert.

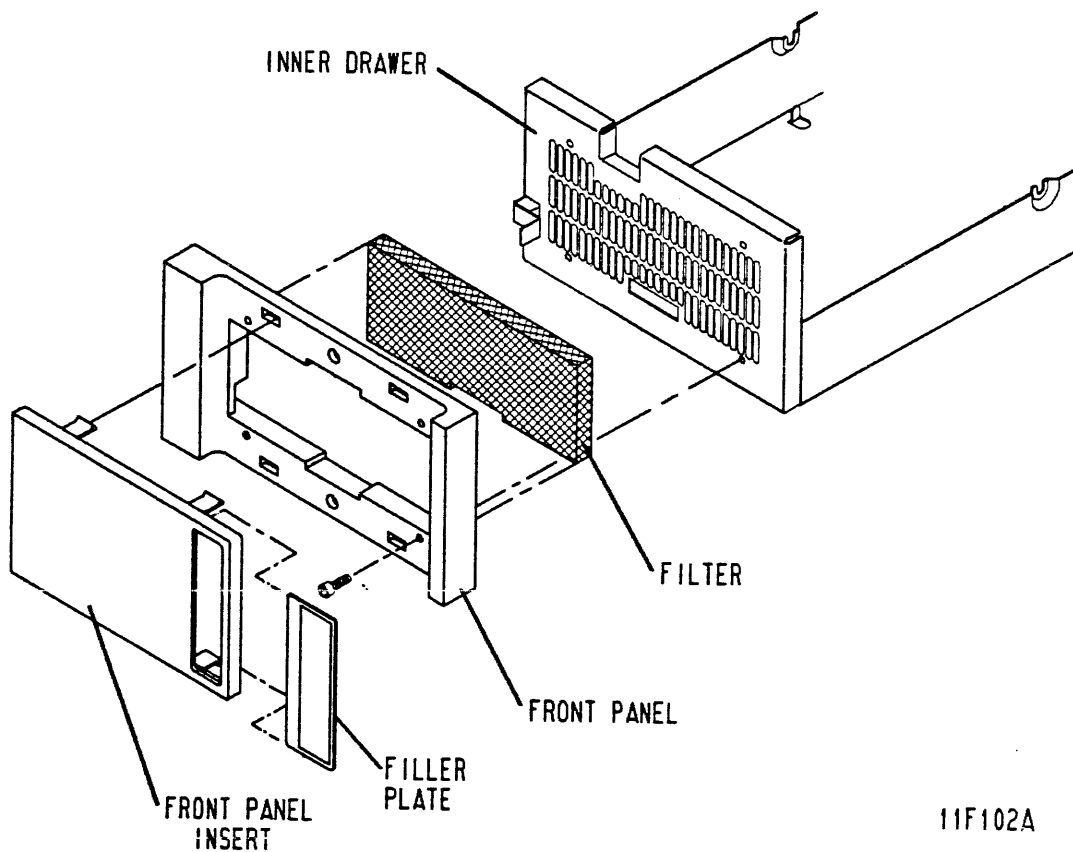

11F102A

Figure 3-7. Mounting Front Panel

MOUNTING OPERATOR PANEL OR STATUS/CONTROL PANEL

The following procedure provides complete instructions for mounting either an operator panel or a status/control panel to an existing 2X drawer configuration. Figure 3-8 shows this mounting for the status/control panel, and figure 3-9 shows it for the operator panel.

If you are mounting the panel as part of a new site 2X drawer installation, then perform steps 19, 20, 21, 22, and either 23 or 24. If you are mounting the panel in an existing installation, you will need to reinstall the drive and power supply as described in this section.

1. Remove front panel insert from each drive.

NOTE

The release latch on the left-hand drive locks the 2X drawer in the rack. The release latch on the right-hand drive has no function.

2. Push 2X drawer release latch to the right and extend 2X drawer to gain access to On/Standby switch on power supply.
3. Remove power from drive by setting On/Standby switch on power supply to Standby (0) position.
4. Push 2X drawer back to closed position in rack.

CAUTION

Remove terminators by hand. They could be damaged if a pliers or other tool is used.

5. Disconnect I/O cables, terminator, and system ground strap from drive.
6. Disconnect ac power cable from site power.
7. Push 2X drawer release latch to the right and extend 2X drawer to fully extended position.

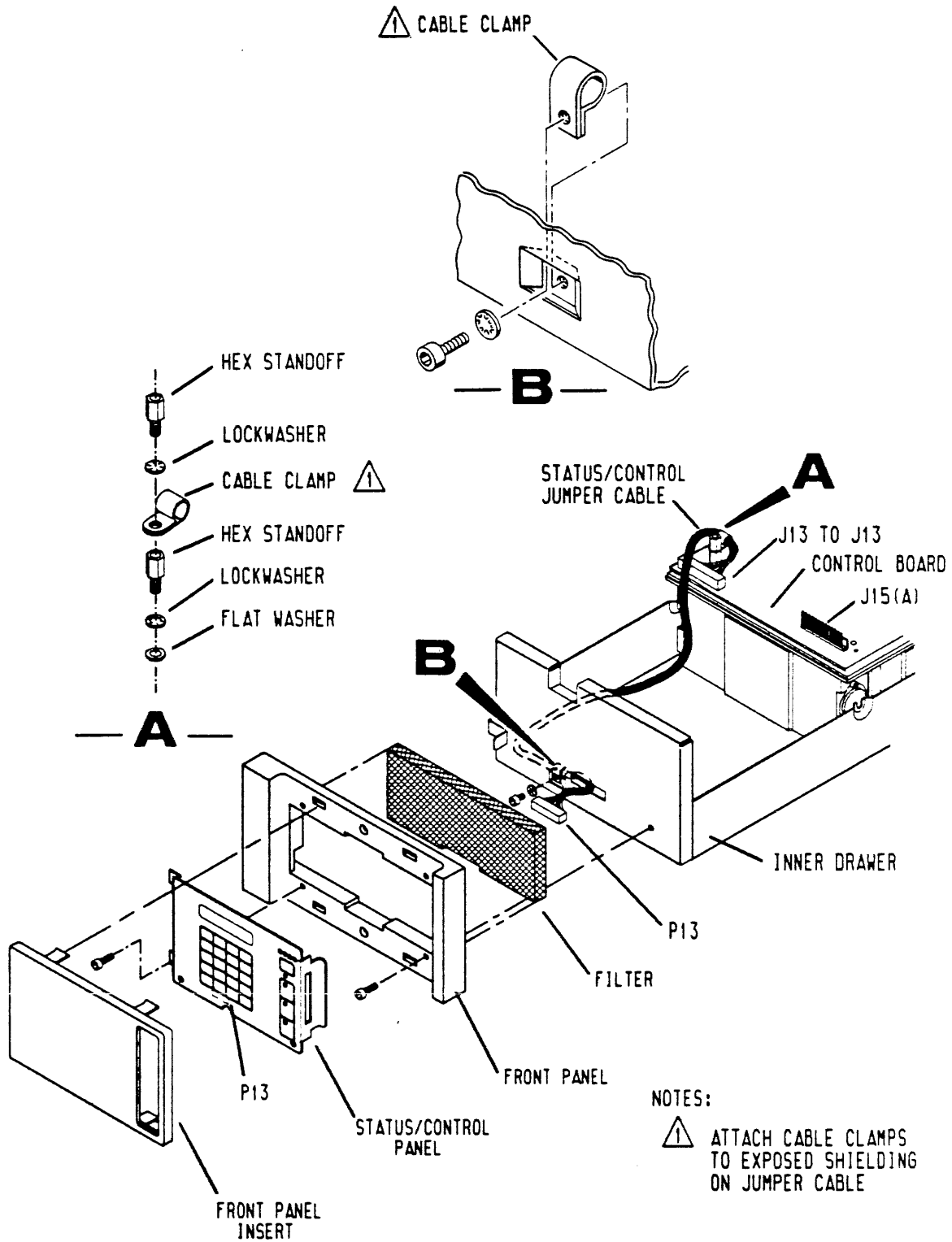

11F50B

Figure 3-8. Mounting the Status/Control Panel

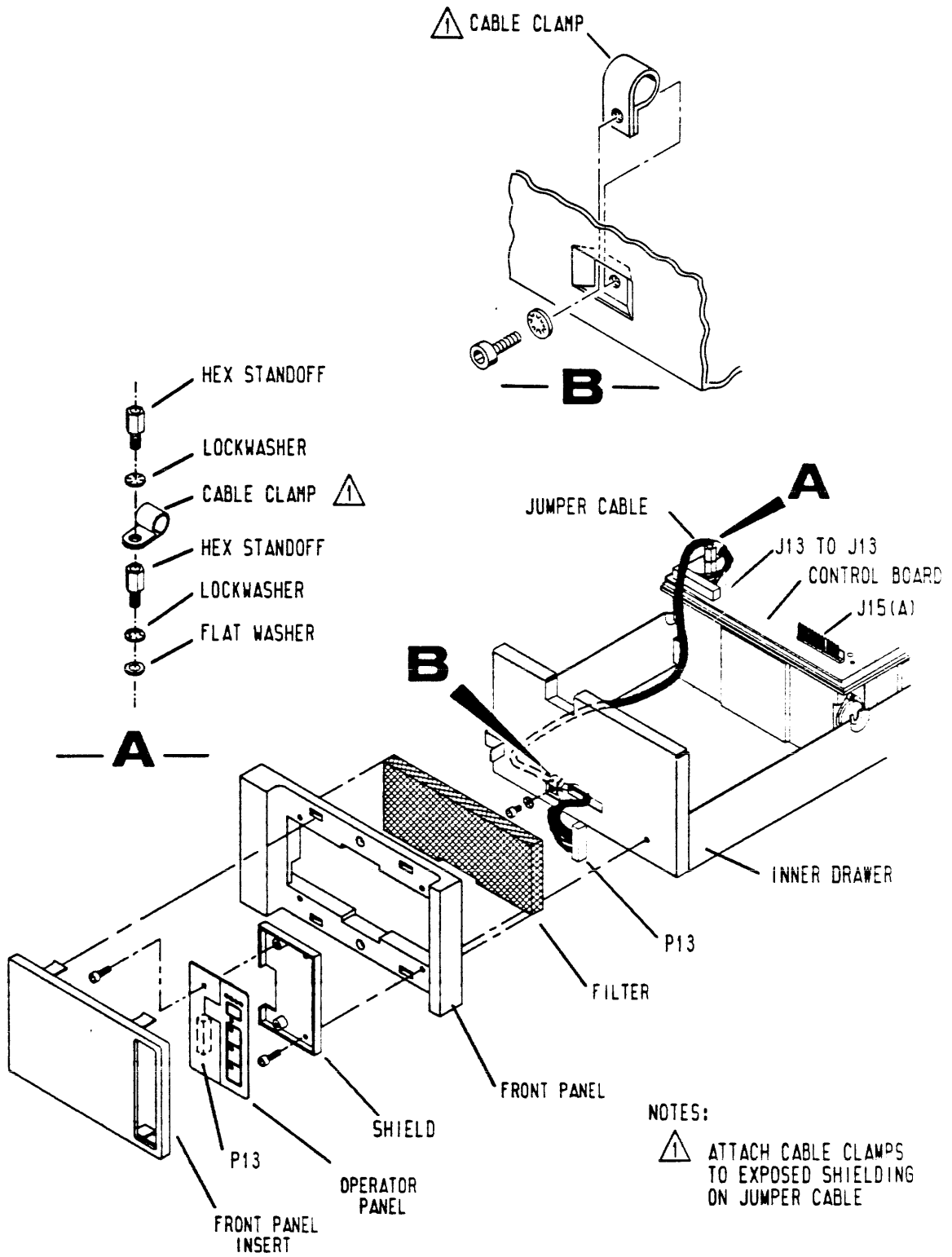

11F130A

Figure 3-9. Mounting the Operator Panel

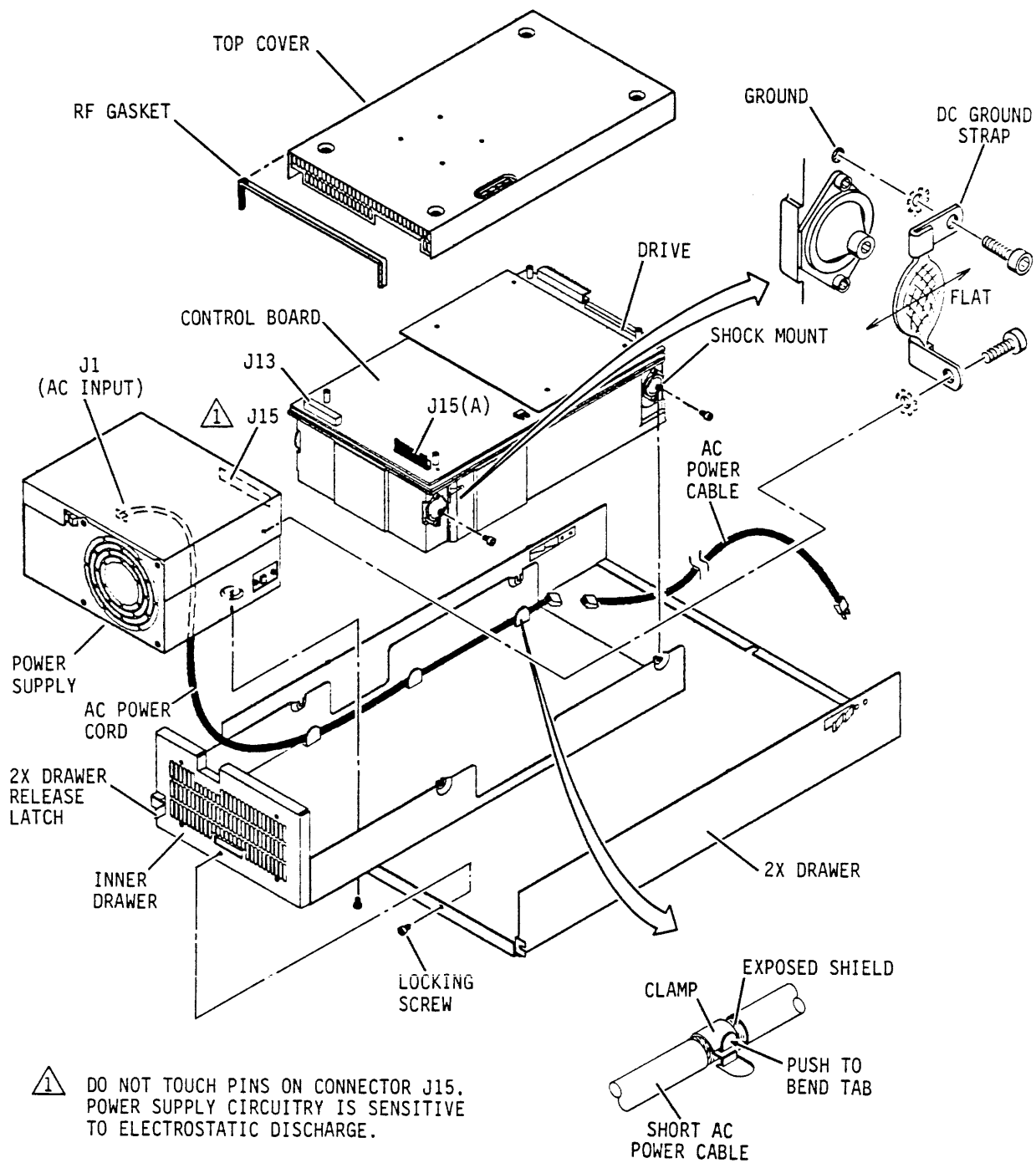

11F374A

Figure 3-10. Mounting Drive and Power Supply in 2X Drawer

8. Remove inner drawer locking screw.
9. Push 2X drawer release latch to the right, lift inner drawer up and remove it from 2X drawer. Place inner drawer on work table.
10. Remove screws securing top cover to drive.

NOTE

To maintain drive configuration whenever the top cover is removed, always identify which drive that the top cover was removed from.

11. Carefully lift off cover.
12. Disconnect dc power cable from J15 (A) on control board.
13. Disconnect dc ground strap from module.
14. Loosen shock mount screws securing module to inner drawer.
15. Carefully lift drive out of drawer and move to desired location.
16. Disconnect ac power cable from ac input connector J1.
17. Remove screws securing power supply to inner drawer.
18. Lift power supply out of drawer and move to desired location.
19. Attach the two metal cable clamps (found in operator panel kit or status/control panel kit) to the exposed shielding on the jumper cable.
20. Attach cable clamp at the P13 end of jumper cable to the inner drawer using a screw and lockwasher.
21. Route jumper cable around left side of where power supply will be.

NOTE

When installing the front panel, ensure that the overhang covers the rack frame (vertical support). If left and right hand inner drawers are interchanged in the 2X drawer, rotate the front panels 180 degrees.

22. Align front panel to inner drawer so that holes in front panel are centered on holes in inner drawer.
23. For a status/control panel installation, perform the following steps:
 - a. Secure front panel into place with two screws on right side of front panel.
 - b. Install filter.
 - c. Connect jumper cable to P13 on status/control panel.
 - d. Align status/control panel to front panel and secure with screws.
 - e. Remove protective film from front surface of status control panel.
24. For an operator panel installation, perform the following steps:
 - a. Secure front panel into place with two screws on left side of front panel.
 - b. Install filter.
 - c. Remove screws attaching operator panel to shield.
 - d. Align shield to front panel and secure with screws.
 - e. Connect jumper cable to P13 on operator panel.
 - f. Align operator panel to shield and secure with screws.

If you are adding the panel to an existing installation, continue with the remaining procedures in this section to reinstall the drive and power supply.

MOUNTING DRIVE AND POWER SUPPLY IN 2X DRAWER

The following procedure provides instructions for mounting the drive and power supply into the 2X drawer. You may find it convenient to make switch settings on the drive and power supply (described in this section) prior to mounting them in the 2X drawer. See figure 3-10. The optional fan kit is not required and must not be installed on the drive when the drive and power supply are mounted in the 2X drawer.

NOTE

For drives with an operator panel or status/control panel, ensure that the P13 jumper cable does not interfere with power supply mounting. Cable is routed around left side of power supply (see figure 3-8 or 3-9).

1. Place power supply into position in inner drawer and secure with screws, supplied with power supply kit.
2. Connect dc power cable to J15 on power supply.
3. Orient ground strap as shown in figure 3-10, and connect ground strap to ac ground terminal on power supply. Ensure that lock washer is placed between ground strap and power supply case.

NOTE

If short ac power cable is not used, ignore steps about clamping cable shield to inner drawer (steps 4a and 4e).

4. Connect short ac power cable as follows:
 - a. Remove heat shrink from short ac power cable to expose shield in area shown in figure 3-10.
 - b. Connect cable to ac input connector J1 on power supply.
 - c. Route cable inside inner drawer as shown in figure 3-10.
 - d. Place cable behind tabs in inner drawer. Exposed shield must be behind tab as shown.
 - e. Place clamp over tab and shield. Bend tab to firmly secure clamp.

5. Loosely attach shock mount screws to drive shock mounts.
6. Mount drive to inner drawer so that drive is supported on shock mount screws.
7. Lift front end of drive up enough to connect dc power cable to J15(A) on control board.
8. To complete installation of status/control panel or operator panel jumper cable, perform the following steps:
 - a. Attach cable clamp at J13 end of jumper cable with screw in hole just above left front shock mount. See figure 3-10. Ensure that lock washer is placed between clamp and module.
 - b. Lift front end of drive up enough to connect jumper cable end marked J13 to J13 on control board.
9. Attach ground strap to drive module. See figure 3-10.
10. Tighten shock mount screws to secure drive in place.
11. Slide inner drawer into position in 2X drawer and secure with locking screw.
12. Push 2X drawer back to closed position in rack.
13. Replace front panel insert.
14. Connect one end of ac power cable to short ac power cable and other end to site power.

ALTERNATE METHODS FOR INSTALLING THE DRIVE

Any alternate method of mounting the drive in an enclosure must satisfy certain requirements regarding mechanical isolation and air flow. The mounting design must support the drive by its shock mounts, either horizontally or vertically. It must allow adequate clearance between the drive and any surfaces near the drive. The mounting design must also ensure adequate ventilation of the drive and power supply. The optional fan kit must be installed at the rear of the drive to provide adequate ventilation if the power supply is mounted remotely from the drive. The fan kit is not required if the drive and power supply are mounted in-line. You may find it convenient to set the various switches as required for normal operation prior to mounting the drive and power supply in the enclosure.

When the power supply mounting is remote from the drive, a shielded dc power cable is recommended. Figure 3-11 shows how the cable connects to the power supply and the drive. One end of the cable connects to J15 on the power supply, and the trailing ground lead on that end connects to the ac ground terminal on the power supply. The other end of the cable goes to J15(B) on the drive. The trailing ground lead on that end connects to the screw above the I/O connectors.

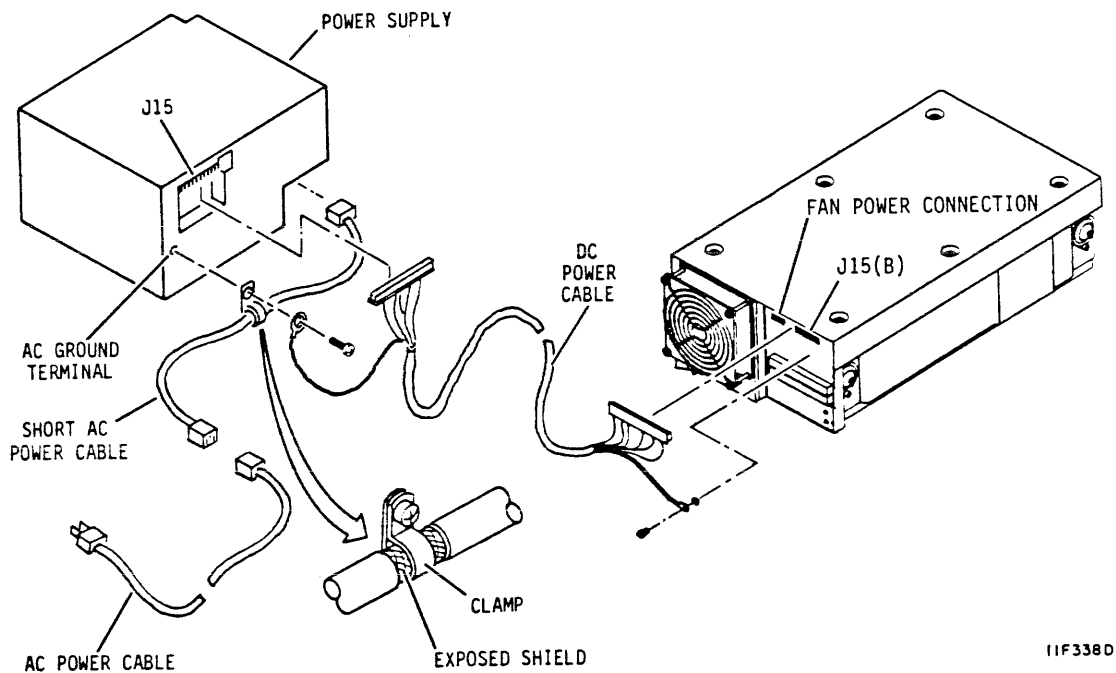
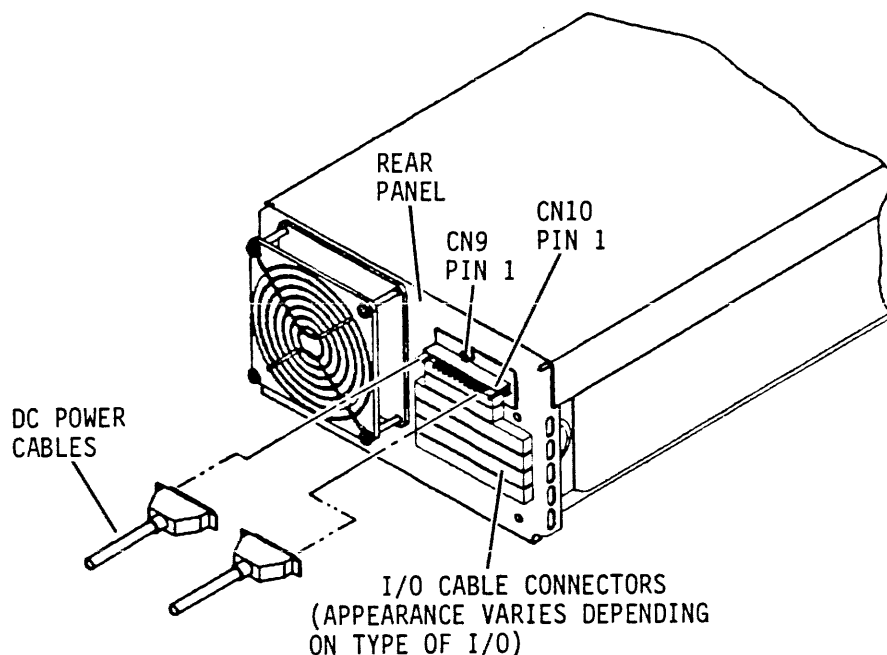

Figure 3-11. Remote Power Supply Cabling

When installing a remote power supply for 60 Hz operation, we recommend that you use a shielded ac power cable and connect the shield to the power supply case. As shown in figure 3-15, you must remove heat shrink from the short ac power cable to expose the shield. Then install a cable clamp on the shield and attach it to the ac ground screw on the power supply. Finally, connect one end of the ac power cable to the short ac power cable and the other end to site power.

Some drives operate from a power source supplying -12 V, +5 V, and +24 V. They contain a voltage converter that develops an additional supply voltage of -5 V from the -12 V input. As shown in figure 3-11.1, these drives have two dc power connectors, CN9 and CN10, located side-by-side above the I/O connectors. Following the directions provided with the power supply, connect the two dc power cables from the supply to CN9 and CN10. The following list provides pin assignments for these connectors:

<u>Connector</u>	<u>Pin Number</u>	<u>Signal</u>
CN9	1	+5 V
	2	+5 V
	3	+24 V return
	4	+24 V return
	5	+24 V
	6	Key
	7	+24 V
CN10	1	-12 V return
	2	Key
	3	-12 V return
	4	-12 V
	5	-12 V
	6	+5 V return
	7	+5 V return



11F128B

Figure 3-11.1 Cabling for a Drive with a Voltage Converter

SYSTEM I/O CABLING

I/O connections between the host and first drive, and between the first and subsequent drives, can have inputs and outputs on either I/O connector (J06 and J07). The I/O input to the last drive in a string must have the I/O cable connected to the lower connector (J07). A terminator must be installed on the upper connector (J06) of the last drive in the string. Figure 3-12 shows typical I/O cable connections.

The drive is equipped for connection of unshielded I/O cables. If shielded cables are used, the I/O connector adapter is required. This adapter connects to the I/O connectors on the I/O board. The shielded I/O cables then connect to this board.

CAUTION

The drive is equipped with keyed connectors to help prevent equipment damage due to improper connections. Equipment damage could result if customer-supplied cables with unkeyed connectors are improperly connected (reversed) at J06 and/or J07.

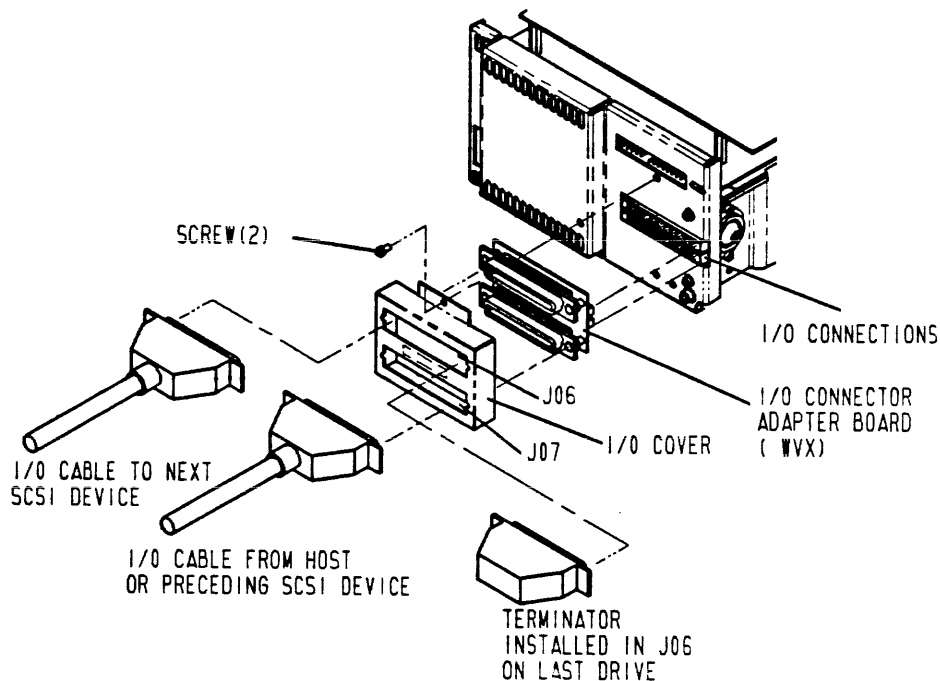

11F142

Figure 3-12. I/O Cable Attachment (Sheet 1 of 2)

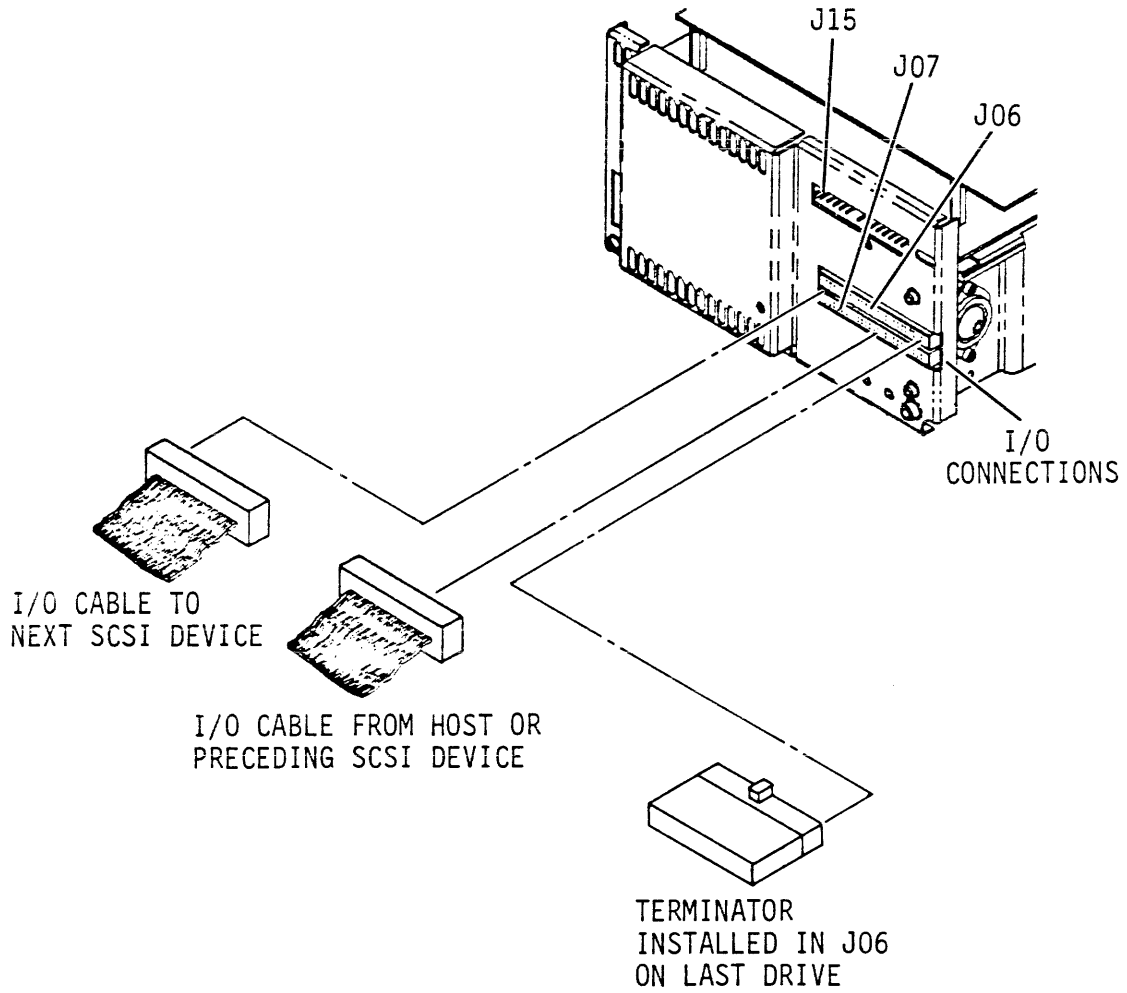

11F143A

Figure 3-12. I/O Cable Attachment (Sheet 2)

SYSTEM GROUNDING

Grounding the system through the power cables and I/O cables is usually sufficient to protect against noise and emissions. If additional protection is required, the following instructions are recommended for grounding the system.

This section describes grounding the system to the drive. It is assumed that the site has been prepared in accordance with the site requirements information provided earlier in this section. Refer to Accessories in section 4 for part numbers of grounding accessories.

Interconnect cabling is supplied with each drive and must be installed between case ground on each drive and case ground on its power supply. Refer to mounting drive and power supply procedure in this section for instructions on attaching ground cable between drive and power supply.

A ground strap connects the host system ground point to the first drive in the string. The remainder of the drives are connected by grounding straps between the first drive and the second, the second and third, and so on, as shown in figure 3-13.

1. Allowing sufficient length for drive extension, cut ground straps to length needed to connect first drive to the host. Additional straps are needed to connect first drive to second, second to third, etc.
2. Crimp and solder terminal lugs to both ends of each ground strap.
3. Refer to figure 3-13 and connect a ground strap to host system ground point. If host system ground point is not already connected to earth ground, prepare and connect another ground strap and make this connection.
4. Make the daisy chain ground connections at each drive as follows:
 - a. Remove screw and lockwasher from system ground terminal (DC GND) on each drive. See figure 3-14.
 - b. Attach system ground straps to drive ground terminal. Ensure lockwasher is between ground strap and ground terminal.

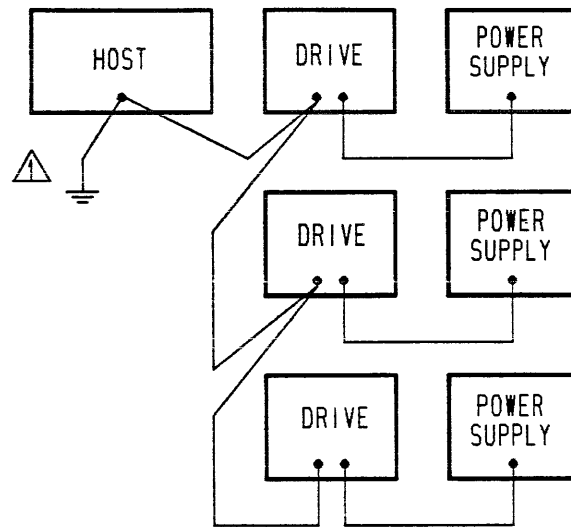

NOTES:

⚠ EARTH GROUND CONNECTION

11F139

Figure 3-13. System Grounding Diagram

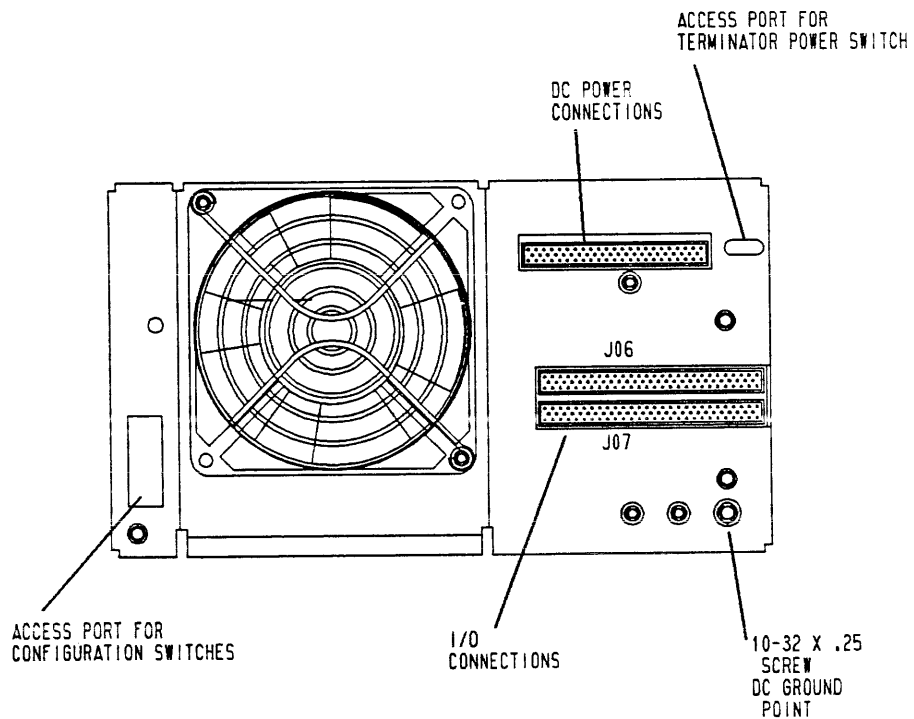

11F140

Figure 3-14. System (DC) Ground Connection

SETTING CIRCUIT BOARD SWITCHES

The circuit boards inside the drive contain a number of switches that must be set correctly for normal operation of the drive. The following pictures and tables contain information about switch settings:

- Figure 3-15 -- identifies switches and gives their locations on the I/O board.
- Table 3-5 -- lists the possible settings for normal drive operation for all switches on the I/O board.
- Figure 3-16 -- identifies switches and jumpers and gives their locations on the control board.
- Table 3-6 -- lists the possible settings for normal drive operation for switches on the control board.
- Table 3-7 -- lists the possible settings for normal drive operation for jumpers on the control board.
- Figure 3-17 -- illustrates the DIP switches and how to operate them.

Setting the circuit board switches does not require removing the top cover. Both the top cover and the rear panel have openings to allow access to the DIP switches. You will need to remove the top cover to examine or change the setting of the control board jumpers.

You may encounter two types of switches. Rocker switches are actuated by pressing one end of the switch or the other (rocking it) to turn the switch on (closed) or off (open). Slide switches are actuated by sliding the actuator one way or the other to turn the switch on or off. Use a slender ball point pen, a straightened paper clip, or similar object to change switch settings. Do not use a lead pencil point as it may break off and lodge in the switch, or cause the switch to malfunction.

The switches on the I/O board at the rear of the drive are reached through holes in the rear panel. Factory switch settings can vary between drive models. Check the settings and change them if necessary to best meet your needs.

Some switch settings must not be changed from the factory setting. This and the other switch setting information is provided in the table on the next page.

NOTE

DIP switches 5, 6, and 7 (ID2, ID1, and ID0) on the I/O board determine the SCSI target ID. Do not confuse these switches with the address switch and indicators on the operator panel or status/control panel, or the address switches on the control board. The SCSI controller (I/O board) will recognize only logical address zero. Therefore, the logical address for the drive must always be set to zero.

ACCESS PORT FOR TERMINATOR POWER SWITCH

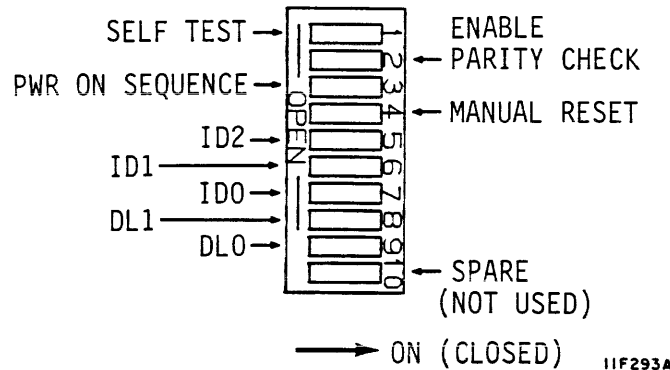
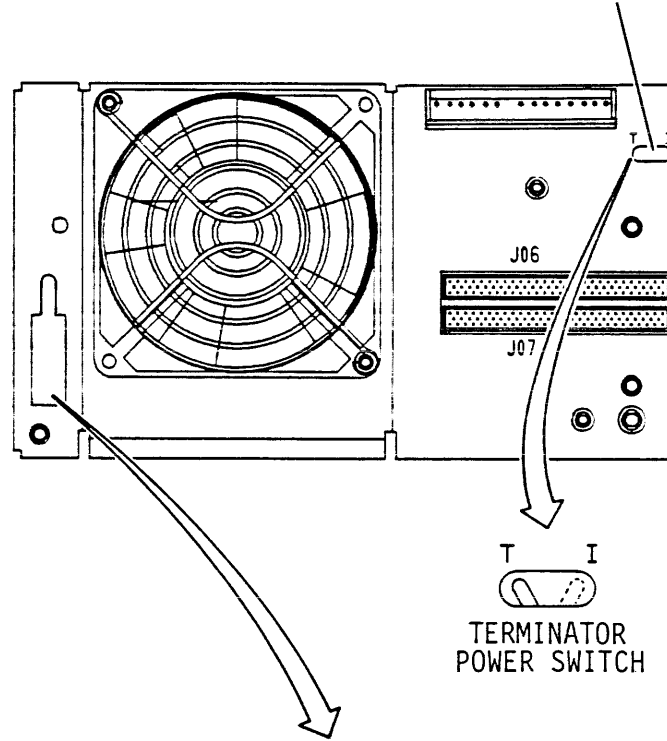

Figure 3-15. I/O Board Switches

TABLE 3-5. I/O BOARD SWITCHES

Switch	Setting	Description
Terminator Power (SW2)	I (Initiator)	Terminator power is provided by initiator over interface. Factory set to this position.
	T (Target)	Terminator power is supplied by the drive.
Self Test (DIP SW1)	Off (Open)	Allows normal operation.
	On (Closed)	Allows looping (offline only) on controller diagnostics.
Enable SCSI Bus Parity Check (DIP SW2)	Off (Open)	Prevents SCSI parity check.
	On (Closed)	Allows SCSI parity checking.
Power On Sequence (DIP SW3)	Off (Open)	Allows normal power up sequencing.
	On (Closed)	Allows immediate power up of the drive.
Manual Reset (DIP SW4)	Off (Open)	Normal operation.
	On (Closed)	Moving switch to this position then back to off (open) causes a SCSI reset.

Table Continued on Next Page

TABLE 3-5. I/O BOARD SWITCHES (Contd)

Switch	Setting	Description																																				
ID2, ID1, ID0 (DIP SW5 - SW7)		<p>Assigns a unique SCSI Bus Target ID to each drive as selected from the chart below.</p> <table border="1"> <thead> <tr> <th>TARG ID</th> <th>SW5 ID2</th> <th>SW6 ID1</th> <th>SW7 ID0</th> </tr> </thead> <tbody> <tr> <td>0</td> <td>Off</td> <td>Off</td> <td>Off</td> </tr> <tr> <td>1</td> <td>Off</td> <td>Off</td> <td>On</td> </tr> <tr> <td>2</td> <td>Off</td> <td>On</td> <td>Off</td> </tr> <tr> <td>3</td> <td>Off</td> <td>On</td> <td>On</td> </tr> <tr> <td>4</td> <td>On</td> <td>Off</td> <td>Off</td> </tr> <tr> <td>5</td> <td>On</td> <td>Off</td> <td>On</td> </tr> <tr> <td>6</td> <td>On</td> <td>On</td> <td>Off</td> </tr> <tr> <td>7</td> <td>On</td> <td>On</td> <td>On</td> </tr> </tbody> </table>	TARG ID	SW5 ID2	SW6 ID1	SW7 ID0	0	Off	Off	Off	1	Off	Off	On	2	Off	On	Off	3	Off	On	On	4	On	Off	Off	5	On	Off	On	6	On	On	Off	7	On	On	On
TARG ID	SW5 ID2	SW6 ID1	SW7 ID0																																			
0	Off	Off	Off																																			
1	Off	Off	On																																			
2	Off	On	Off																																			
3	Off	On	On																																			
4	On	Off	Off																																			
5	On	Off	On																																			
6	On	On	Off																																			
7	On	On	On																																			
DL1 - DL0 (DIP SW8 SW9)	On (closed)	These switches are set to the on (closed) position at the factory. This setting must not be changed.																																				
Spare (DIP SW10)	Off (Open)	This switch is not used. It is set to the off (open) position at the factory.																																				

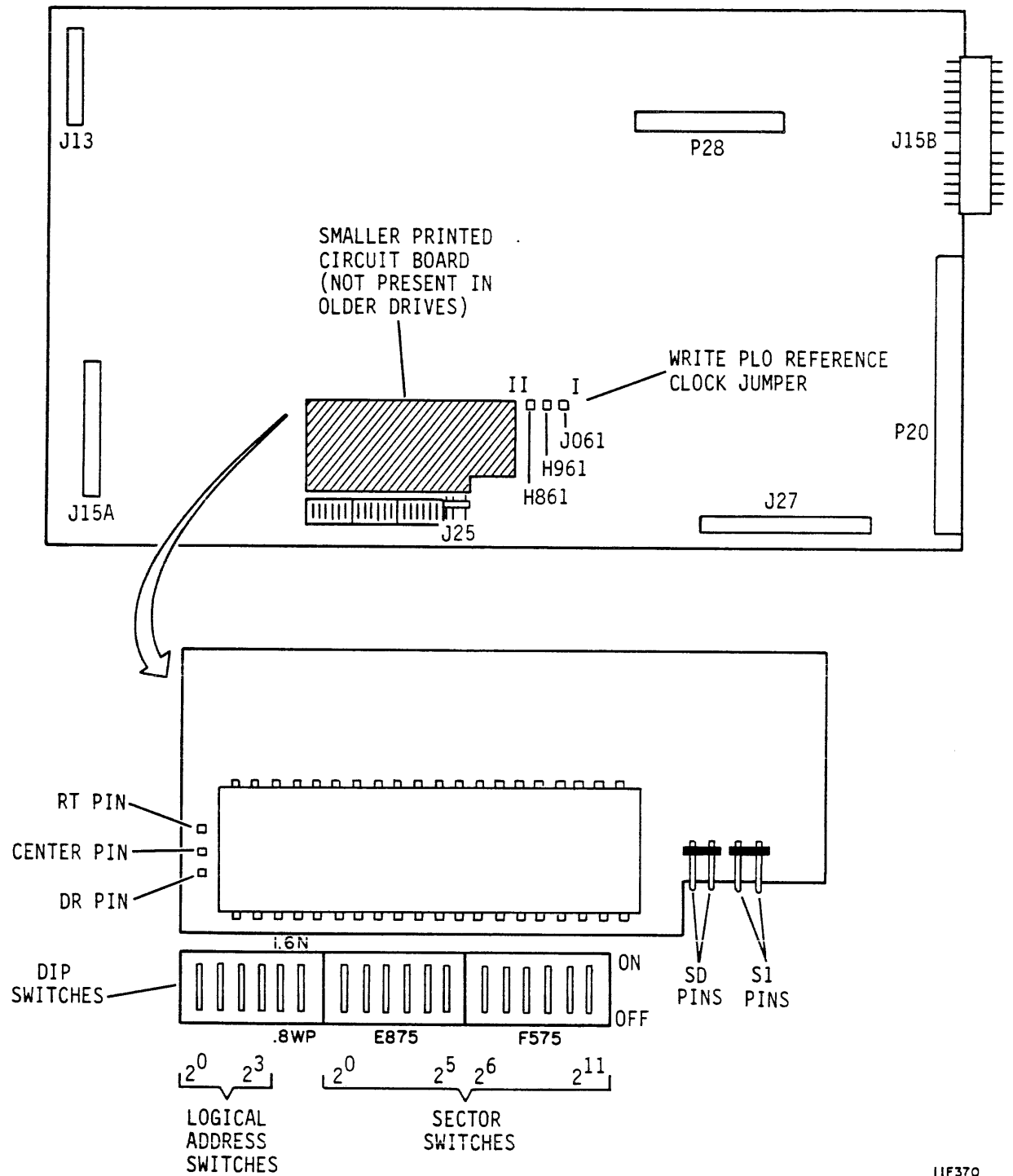

Figure 3-16. Control Board Switches and Jumpers

TABLE 3-6. CONTROL BOARD SWITCHES

Switch	Setting	Description
Sector Switches		2 ⁰ is set to on (closed). 2 ¹ - 2 ¹¹ are set to off (open). Do not change these factory settings.
Logical Address Switches		2 ⁰ - 2 ³ set to on (closed) (address 0) at the factory. Do not change these settings as only logical address 0 is recognized.
.8/1.6	.8 (Off/Open)	Selects 0.8 MHz Sector Clock frequency. Setting must not be changed.
	1.6 (On/Closed)	This setting is not used.
WP/N	WP (Off/Open)	Write Protect: prevents write operations
	N (On/Closed)	Normal: allows write operations

TABLE 3-7. CONTROL BOARD JUMPERS

Jumper	Setting	Description
S1*	Connected	Disables the option for sweep cycle only on seeks. This setting is not used.
	Disconnected	Enables the option for sweep cycle only on seeks. Drive is shipped with this jumper disconnected.
SD*	Connected	Disables sweep cycle operation.
	Disconnected	Enables sweep cycle operation. Drive is shipped with this jumper disconnected.
DR/RT	Disconnected (DR)	Disables the option to return heads to their original position following a sweep segment. If sweep cycle is enabled (jumper SD disconnected), this setting must not be used.
	Connected (RT)	Enables the option to return heads to their original position following a sweep segment only if drive was selected during last 12 minutes. If drive was not selected during last 12 minutes, the heads stay on the last track the sweep segment moved them to.
Write PLO Reference Clock Jumper	I	Jumper is properly set at factory and must not be changed. For 368 MB drives, jumper is installed during manufacturing between H961 and J061.
	II	For 500 MB drives, jumper is installed during manufacturing between H861 and H961.
* For explanation, see Sweep Cycle Information.		

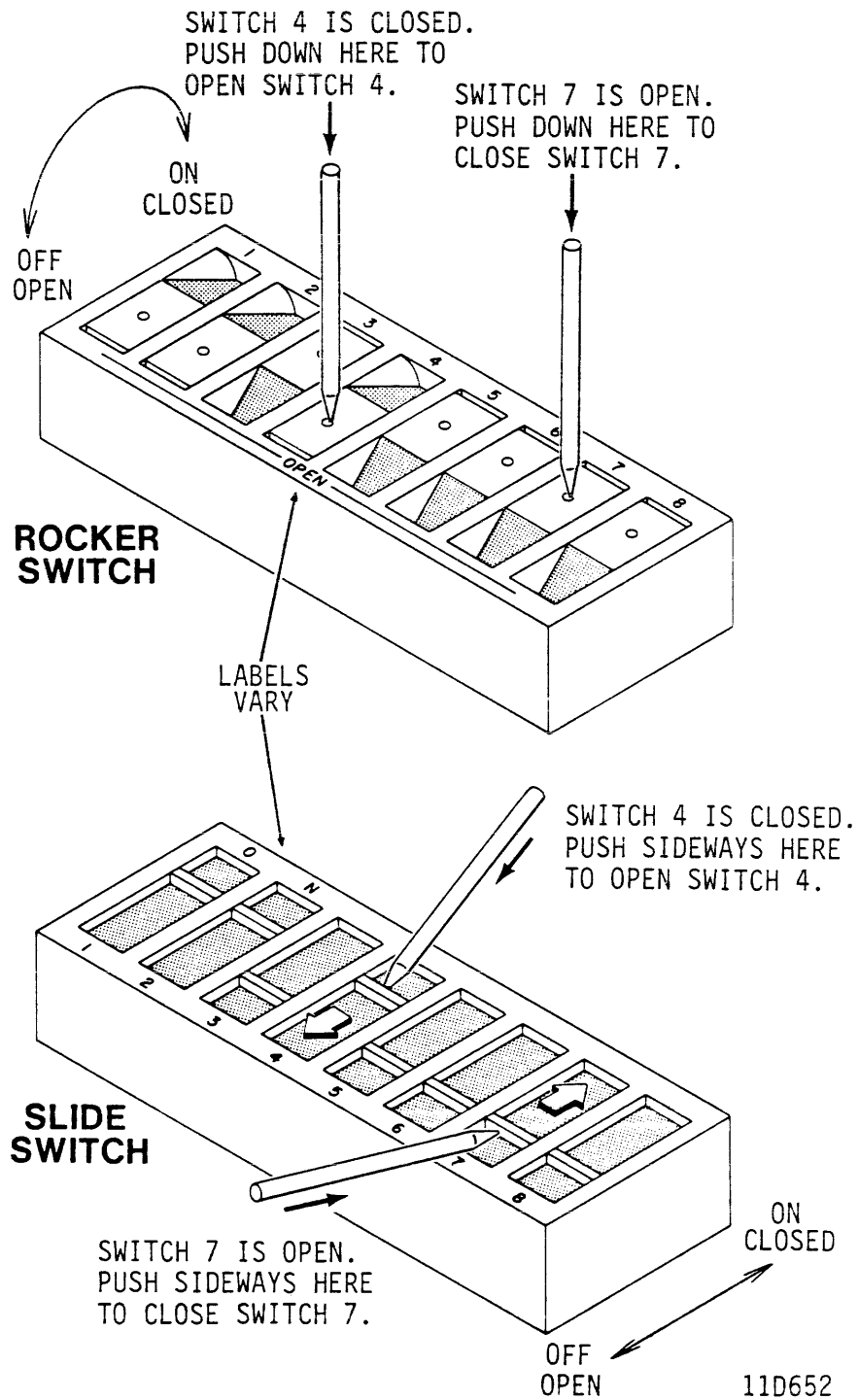

Figure 3-17. How To Set DIP Switches

SWEEP CYCLE INFORMATION

The sweep cycle is a feature that periodically moves the heads to different locations on the disks during periods when the drive is idle. Some advantages of using a sweep cycle are:

- It enhances drive reliability. You are encouraged to use the drive sweep cycle or to use a sweep cycle that is controlled by the host (initiator). Consult with a systems analyst before making this choice.
- The sweep cycle routine only takes about 11 seconds in a 13 hour period. This means the drive is still available to the system more than 99% of the time.
- You may disable the sweep cycle without affecting the specified Mean Time Between Failures (MTBF) or warranty agreements.

WHICH DRIVES HAVE THE SWEEP CYCLE FEATURE

- Early drives that do not have the smaller circuit board on the control board cannot perform the sweep cycle function.
- Some early drives with the smaller circuit board on the control board cannot perform sweep cycles because of I/O board microcode constraints. These drives were shipped from the factory with the sweep cycle feature disabled (SD jumper connected). These drives must not have the sweep cycle feature enabled.
- Later drives are able to perform sweep cycles. These drives are shipped from the factory with the sweep cycle feature enabled (SD jumper disconnected). You may disable the sweep cycle feature on these drives if desired.

HOW TO ENABLE THE SWEEP CYCLE FEATURE

To enable the sweep cycle feature, the jumpers must be set as follows:

- Disconnect the SD jumper. This enables the sweep cycle feature.

- Disconnect the S1 jumper. This allows sweep movements to occur only in conjunction with seeks issued by the SCSI I/O board. The drive logic adds a sweep cycle to a seek issued by the SCSI I/O board at about 12 minute intervals. If about 15 minutes elapses with no disk access commands received from the SCSI Bus, the SCSI I/O board sends a one-track seek to the control board which causes the drive to perform its sweep cycle. The drive adds a one-track seek each 12 minutes, even if the sweep cycle is disabled. The SCSI I/O board does not issue seeks to initiate a sweep cycle until 2 hours after power on.
- Connect the RT jumper. This causes the heads to return to the original cylinder (the cylinder following the one-track seek) after the sweep segment is completed.

NOTE

If the S1 and DR/RT jumpers are not set as described, conflicts between sweep accesses and SCSI I/O accesses can occur. This can cause a DRIVE NOT READY condition.

HOW TO DISABLE THE SWEEP CYCLE FEATURE

To disable the sweep cycle feature, connect the SD jumper. The setting of the S1 and DR/RT jumpers should not be changed, although their setting is irrelevant when the SD jumper is connected. If disk access commands are not received during any 15 minute interval, the I/O board still issues a one-track seek even though sweep cycles are disabled.

CHECKOUT

POWER ON SEQUENCE ENABLED

1. Place Power On Sequence switch (DIP switch 3) on I/O board in off (open) position.
2. Set terminator power switch (SW2) to I (Initiator) on all drives in string except for last drive. Set its terminator power switch to T (Target) if the drive supplies terminator power, or to I if terminator power is supplied by the initiator.

NOTE

For drives with no operator panel or status/control panel, power on sequence begins (but delayed as explained in step 5) when power supply On/Standby switch is placed in On (1) position.

3. Set On/Standby switch at rear of power supply in On (1) position and observe that power supply cooling fan operates.
4. Set drive logical address to zero (0) on all drives. Only address zero is recognized. The drive is addressed by its Target ID assigned to the SCSI controller (I/O board) when the drive was installed.
5. Press START switch on drives with operator panel or status/control panel. The power on sequence for each drive continues at this point, but is delayed in increments of five seconds depending on the Target ID assigned to the drive. If drive is assigned Target ID 3 for example, it starts after a 15-second delay. Delay times for each Target ID are:
 - Target ID 0 = 0 seconds
 - Target ID 1 = 5 seconds
 - Target ID 2 = 10 seconds
 - Target ID 3 = 15 seconds
 - Target ID 4 = 20 seconds
 - Target ID 5 = 25 seconds
 - Target ID 6 = 30 seconds
 - Target ID 7 = 35 seconds

Observe that Ready indicator, located in START switch, flashes rapidly. This indicates power up sequence has started.

6. Observe that Ready indicator on operator panel or status/control panel stops flashing but stays on within 90 seconds. This indicates drive motor is up to speed and heads are at track 0. If drive has no operator panel or maintenance/operator panel, observe that RDY LED on the control board lights to indicate that drive is ready.

If all of these events occurred, the drive is ready for online operation. Refer to the troubleshooting information either in appendix A of this manual or in the hardware maintenance manual if a problem exists in the drive.

POWER ON SEQUENCE DISABLED

Operation of the drive with the Power On Sequence DIP switch 3 set to on (closed) eliminates the delay portion of the start sequence. This allows each drive to start immediately when the START switch on the operator panel or status/control panel is pressed. If the drive has no operator panel or status/control panel, the start sequence begins when the power supply On/Standby switch is set to the on (1) position. All other aspects of the start sequence are identical to the Power On Sequence Enabled sequence.

START/STOP UNIT COMMAND

The Start or Stop Unit command (1B) can be used to stop and start the drive after it has been initially started.

SECTION 4

PARTS DATA

INTRODUCTION

This section contains listings of field replaceable parts, manufacturer's recommended spare parts, and accessories. Use only Imprimis replacement parts. Using non-Imprimis replacement parts can adversely affect safety. Using other manufacturers' parts could also degrade reliability, increase maintenance downtime, and void warranty coverage.

NOTE

ORDER AND REPLACE LOGIC BOARDS BY PART NUMBER ONLY.

Logic boards have an alpha card type designator stamped on them. In the past, ECOs that changed a board part number also changed the first letter of the designator (AWXY to BWXY). Effective 1 August 1987, only the part number changes. The card type does not change.

FIELD REPLACEABLE PARTS LIST

This listing is divided into four columns:

- INDEX NO - The numbers in this column correspond to the numbers shown within the facing page illustration.

- PART NUMBER - Contains one of the following:
 1. Eight digit part number - use this number to order a replacement part. Within the continental U.S., parts may be ordered from:

Imprimis Technology Incorporated
Customer Services
5950 Clearwater Drive
Minnetonka, MN 55343

Phone: 1-800-382-6060
Fax: (612) 931-8817

2. Optional - parts that are not used in all applications. To determine usage in a particular equipment, you must first know the Equipment Package part number (refer to Equipment Configuration in section 1 of this manual for definition and location of this number) and then refer to table 4-1. Table 4-1 contains the Equipment Package part number (the first 6 digits are on line 1, and the last 2 digits are on line 2) and a list of optional parts. If an optional part is used in a particular Equipment Package, "XX" will appear in that column.
3. Spare - indicates that the item is a manufacturer's recommended spare part. Refer to table 4-2 for replacement part number information.

- PART DESCRIPTION - Contains part nomenclature/description. If an item is indented more than the previous item, it indicates it is part of the previous item (assembly).
- NOTE - Usually contains entries to define differences between machine configurations (i.e., model differences, older units vs newer units, etc.).

MANUFACTURER'S RECOMMENDED SPARE PARTS

This listing (table 4-2) is divided into three columns:

- DESCRIPTION/NOTES - Contains the part nomenclature/description and other pertinent information.
- PART NUMBER - Contains the part number of the part when the unit was manufactured or as a result of the latest FCO. This part can be used as a replacement on the series code and types of units indicated in the Description/Notes column. However, always use Replacement Part Number when ordering new parts or spares.
- REPLACEMENT PART NUMBER - Contains the interchangeable replacement part number. Use this number for ordering replacement or spare parts.

ACCESSORIES

This listing (table 4-3) contains the following:

- **PART NUMBER** - Use this number to order this part. See Field Replaceable Parts List for ordering information.
- **DESCRIPTION** - Contains the part nomenclature/description.

CARD INTERCHANGEABILITY CHART

The card interchangeability chart (CIC) provides the latest revision level of a card, its title, and its part number for ordering purposes.

Prior to attempting to use the chart, be sure to read and understand the rules for interpreting the CIC as given on sheet 1.

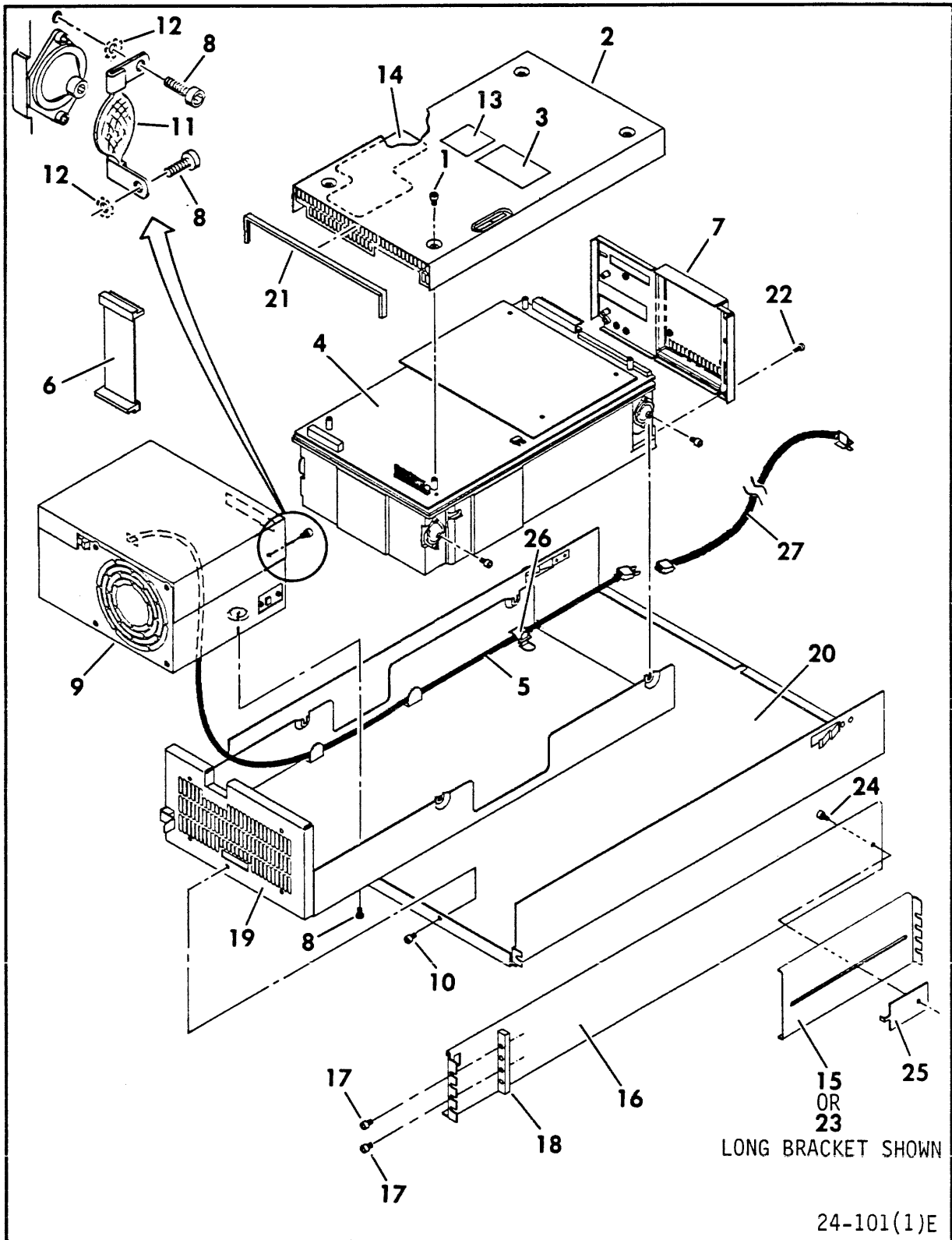

Figure 4-1. Eight-Inch Module Drive (Sheet 1 of 4)

INDEX NO	PART NO	PART DESCRIPTION	NOTE
4-1	Optional	EIGHT-INCH MODULE DRIVE (Sheet 1 of 4)	
1	10127111	SCREW, PHH, 6-32 x 1/4	
2	47010556	COVER, Top, Drive	
3	24547559	LABEL, Warning	Static Electricity
4		DRIVE ELECTRONICS ASSEMBLY (See Figure 4-2)	
5	Spare*	AC POWER CORD, Short	
5	Spare*	AC POWER CORD, Shielded	
5	Spare	AC POWER CORD & FERRITE ASSY	
6	Spare*	DC POWER CABLE ASSEMBLY	6.35 cm/2.5 in
7	46455324	PANEL, Rear	
8	10126217	SCREW, Hex Skt, 6-32 x 1/4	
9	Spare*	POWER SUPPLY	
10	10126226	SCREW, Hex Skt, 8-32 x 1/2	
11	Optional	CABLE, Ground	
12	Optional	WASHER, Lock, 6	
	Optional	RACK MOUNTING KIT ASSEMBLY	
13	21987640	LABEL, FCC	
14	47026720	INSULATOR, Top Cover	
15	45419002	BRACKET, Long, Slide Adjusting, Right	22 cm/8.25 in
	45419003	BRACKET, Long, Slide Adjusting, Left	
16	47048260	SLIDE, Guide, Right	
	47048261	SLIDE, Guide, Left	
17	15002644	SCREW, Hex Skt, 10-32 x 1/2	
18	94376727	PLATE, Nut	
19	47007910	DRAWER, Inner	
20	47048250	DRAWER, 2X	
21	94377005	GASKET, RF	
22	10126220	SCREW, Hex Skt, 6-32 x 5/8	
23	45419004	BRACKET, Short, Slide Adjusting, Right	6 cm/2.7 in
	45419005	BRACKET, Short, Slide Adjusting, Left	
24	10126226	SCREW, Hex Skt, 8-32 x 1/2	
25	75038304	BRACKET, Clamp	
26	Optional	CLAMP, Power Cord	
27	Spare*	AC POWER CORD, Long	

* Also, Optional

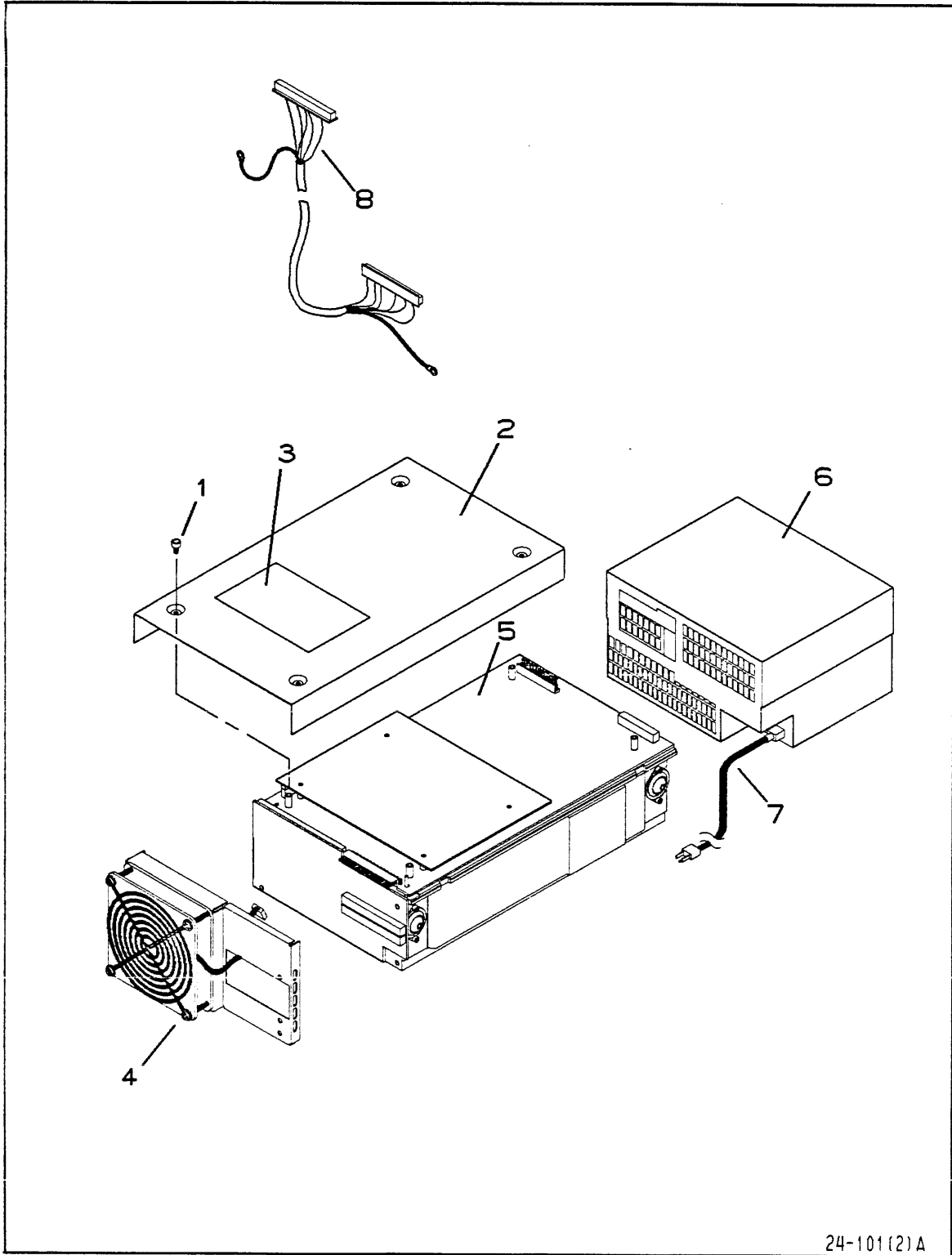

Figure 4-1. Eight-Inch Module Drive (Sheet 2)

INDEX NO	PART NO	PART DESCRIPTION	NOTE
4-1		EIGHT-INCH MODULE DRIVE (Sheet 2)	
1	10127111	SCREW, PHH, 6-32 x 1/4	
2	47010556	COVER, Top Drive	
3	24547559	LABEL, Warning	Static Electricity
4	Optional Spare	FAN MOUNTING KIT ASSEMBLY FAN, 24 V dc	
	70558651	GUARD, Finger	
	81773305	BRACKET, Fan	
	10127119	SCREW, PHH, 6-32 x 1-1/4	
	94047001	WASHER, Special	
5		DRIVE ELECTRONICS ASSEMBLY (See Figure 4-2)	
6	Spare	POWER SUPPLY	
7	Spare	AC POWER CORD	
8	Spare	DC POWER CABLE	1.5 m/5 ft

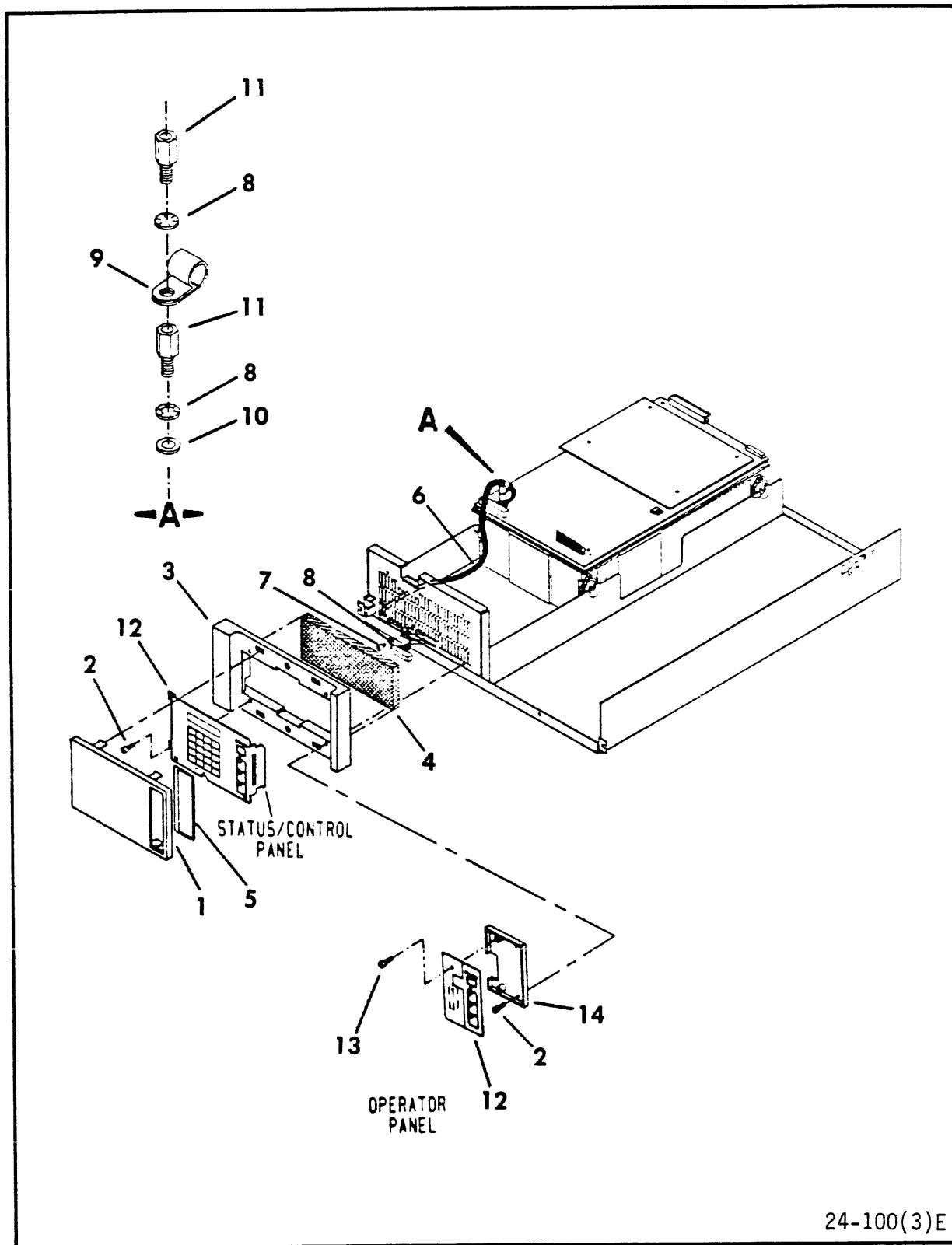
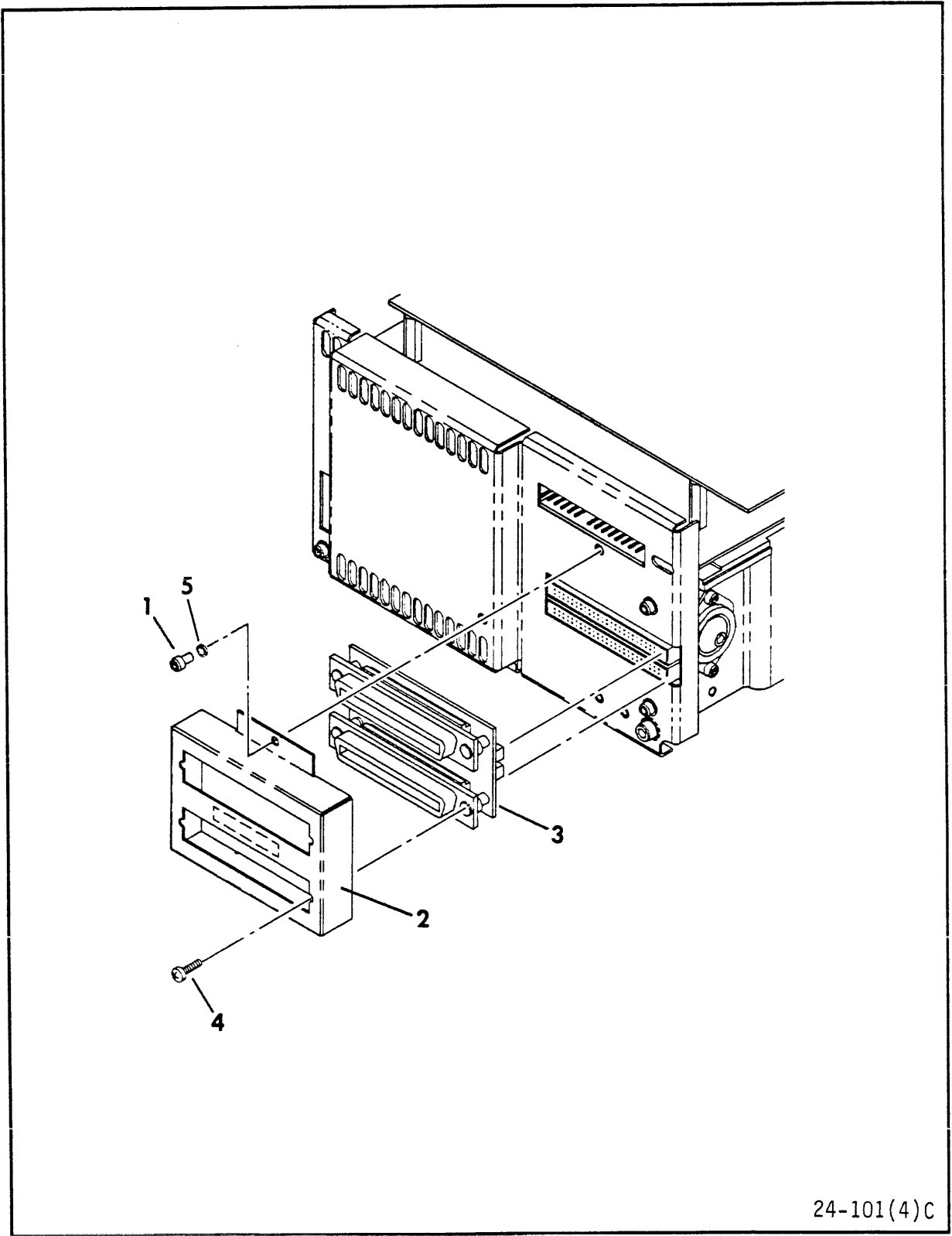

Figure 4-1. Eight-Inch Module Drive (Sheet 3)

INDEX NO	PART NO	PART DESCRIPTION	NOTE
4-1		EIGHT-INCH MODULE DRIVE (Sheet 3)	
1	92536400	INSERT, Front Panel	
2	10126222	SCREW, Hex Skt, 6-32 x 7/8	
3	92517400	PANEL, Front	
4	Spare	FILTER, Primary	
5	46641780	PLATE, Filler	
	Optional	OPERATOR PANEL KIT ASSEMBLY	w/Status Control Panel
	Optional	OPERATOR PANEL KIT ASSEMBLY	w/Operator Panel
6	Spare	JUMPER ASSEMBLY, Status Control	
7	10126217	SCREW, Hex Skt, 6-32 x 1/4	
8	10126103	WASHER, Lock, 6	
9	92777196	CLAMP, Cable	
10	10125605	WASHER, Flat, 6	
11	77613122	STANDOFF	
12	Spare	PANEL, Operator	
13	92721196	SCREW, Hd, 6-32 x 1/4	
14	47060750	SHIELD, Operator Panel	



24-101(4)C

Figure 4-1. Eight-Inch Module Drive (Sheet 4)

INDEX NO	PART NO	PART DESCRIPTION	NOTE
4-1		EIGHT-INCH MODULE DRIVE (Sheet 4)	
	Optional	CONNECTOR ADAPTER KIT	
1	10126217	SCREW, Hex Skt, 6-32 x 1/4	
2	47041310	COVER, Connector	
3		_WVX CONNECTOR ADAPTER BOARD	See Accessories
4	10127111	SCREW, PHH, 6-32 x 1/4	
5	10126103	WASHER, Lock, 6	

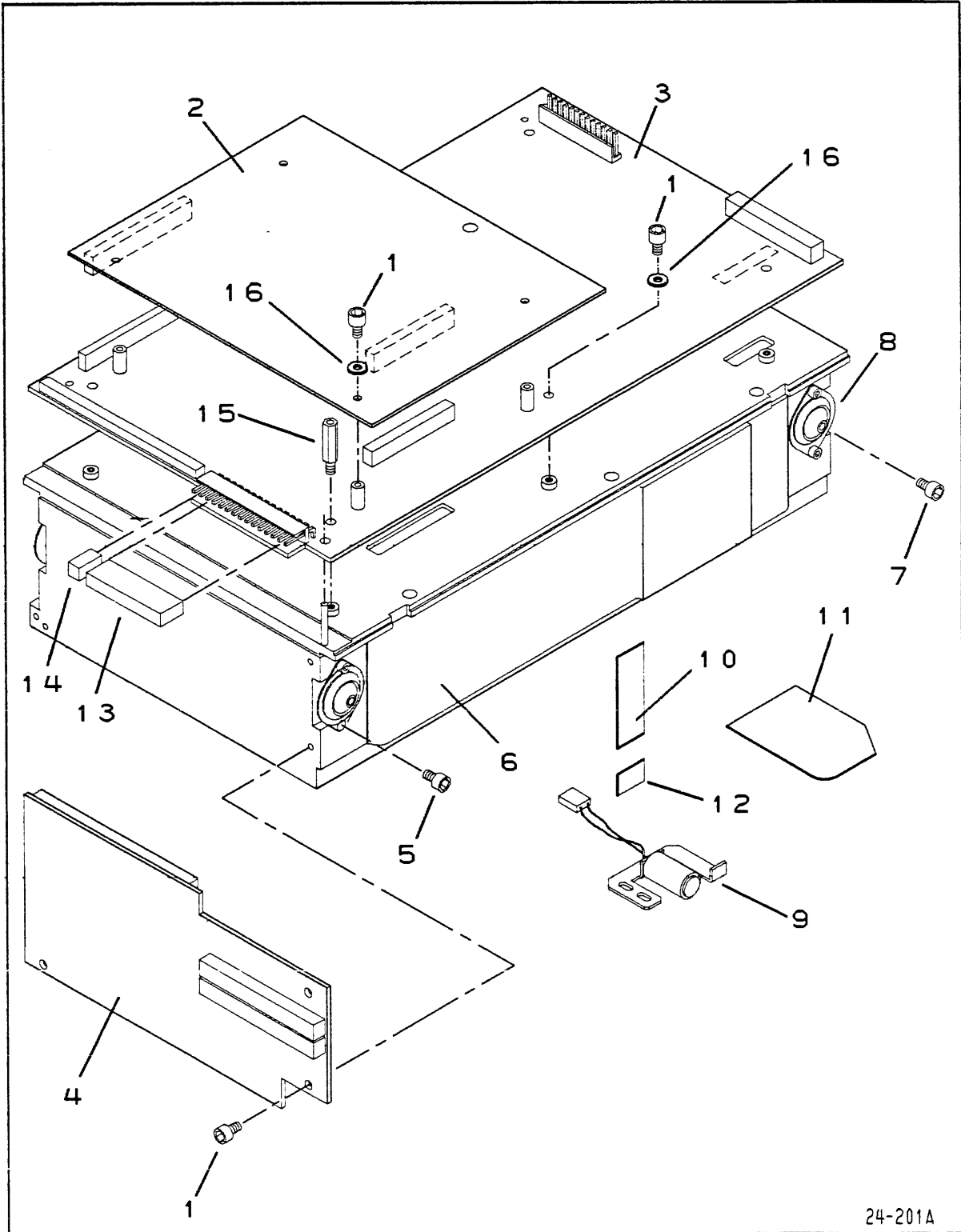

24-201A

Figure 4-2. Drive Electronics Assembly

INDEX NO	PART NO	PART DESCRIPTION	NOTE
4-2		DRIVE ELECTRONICS ASSEMBLY	
1	10126217	SCREW, Hex Socket, 6-32 x 1/4	
2	CIC	READ/WRITE BOARD	
3	CIC	CONTROL BOARD	
4	CIC	I/O BOARD	
5	10126244	SCREW, Hex Socket, 10-32 x 1/2	
6	Spare	FORMATTED MODULE ASSEMBLY	
7	10126218	SCREW, Hex Socket, 6-32 x 3/8	
8	47038411	SHOCKMOUNT	
	Spare	CARRIAGE LATCH ELECTROMAGNET KIT ASSEMBLY	
9	47029920	ELECTROMAGNET, Carriage Latch	
10	46618921	COVER, Cable, Upper	
11	46618911	COVER, Electromagnet	
12	46618922	COVER, Cable, Lower	
13	94388624	CONNECTOR, Housing, 13 Position	
14	94388600	CONNECTOR, Housing, 2 Position	
15	95590407	STANDOFF, 1/4	
16	10126103	WASHER, Lock, 6	

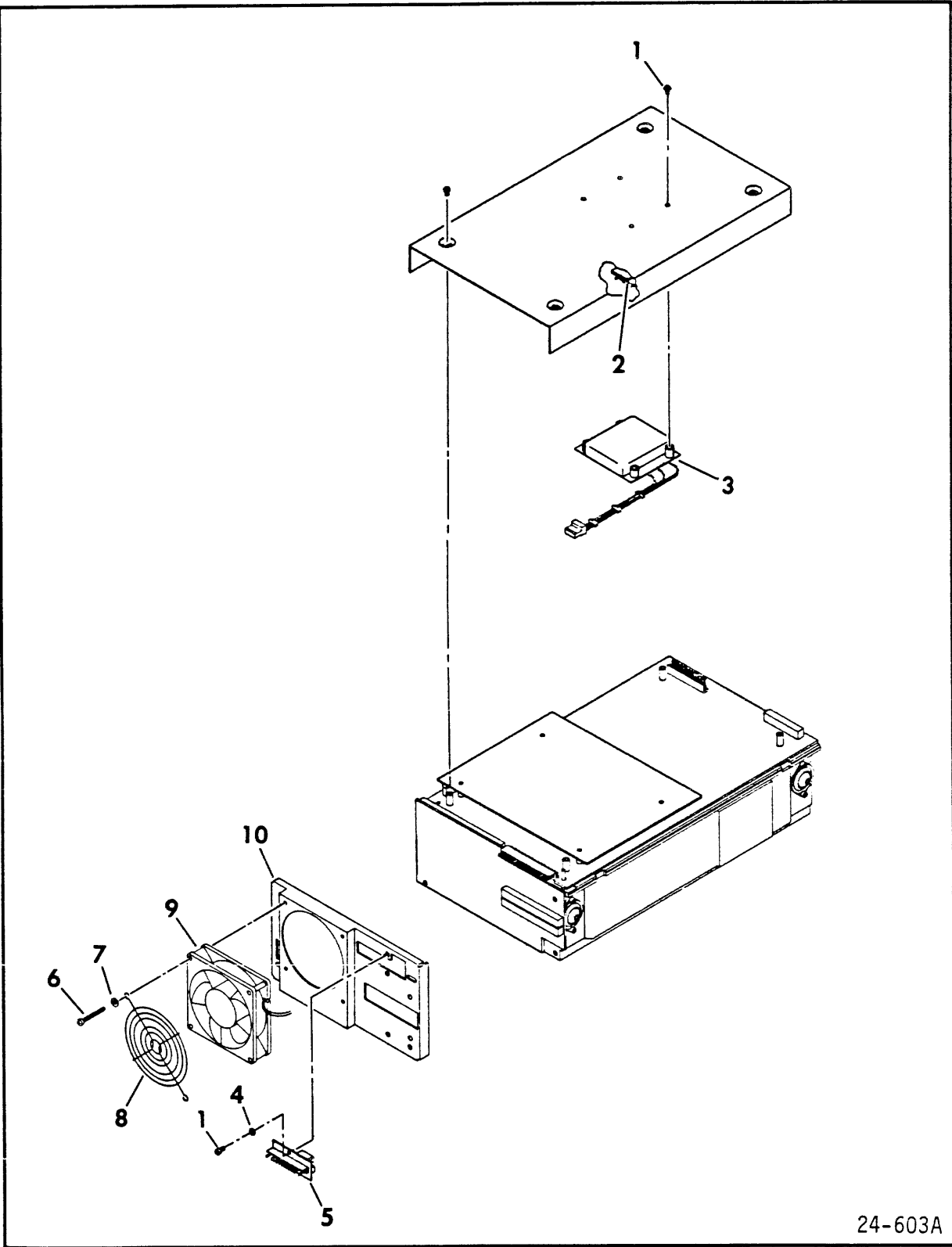

Figure 4-3. DC Voltage Conversion Kit Assembly

INDEX NO	PART NO	PART DESCRIPTION	NOTE
4-3	47039127	DC VOLTAGE CONVERTER KIT ASSEMBLY	PA8E1E
1	92721196	SCREW, Skt Hd, 6-32 x 1/4	
2	94241019	CLIP, Cable	
3	CIC	BXSX VOLTAGE CONVERTER	
4	10126103	WASHER, Lock, 6	
5	CIC	FWTX CONNECTOR ADAPTER BOARD	
6	10127119	SCREW, PHH, 6-32 x 1-1/4	
7	94047001	WASHER, Flat, 6	
8	70558651	GUARD, Finger	
9	Spare	FAN, 24 V dc	
10	81773307	BRACKET, Fan	

TABLE 4-1. OPTIONAL PARTS

PART NO.	PART DESCRIPTION	368 MB* EQUIPMENT PACKAGE 470432xx													
		01	02	03	04	05	06	07	08	15	16	17	18	19	
47044001	PA8B1A DRIVE	XX	XX	XX	XX	XX	XX	XX	XX						
47044002	PA8B1B DRIVE									XX	XX	XX	XX		
47044003	PA8B1C DRIVE													XX	
45070622	POWER SUPPLY	XX	XX	XX	XX	XX	XX	XX	XX	XX	XX	XX	XX	XX	
47141391	AC CABLE SHD		XX								XX				
47127502	AC CABLE & FER	XX	XX	XX	XX			XX		XX	XX	XX		XX	
75168331	AC CABLE SHORT	XX				XX	XX			XX	XX			XX	
47188871	AC CABLE LONG	XX				XX	XX			XX	XX			XX	
92588100	DC CABLE	XX	XX		XX		XX	XX	XX	XX	XX	XX	XX	XX	
92588104	DC CABLE	XX		XX		XX				XX				XX	
15459250	TERM, DIFF, SHD	XX	XX											XX	
15459255	TERM, DIFF, USHD	XX	XX											XX	
15387797	TERM, SE, SHD									XX	XX				
15387807	TERM, SE, USHD									XX	XX				
47191152	I/O CABLE ASSY	XX	XX							XX	XX			XX	
45419405	FAN MTG KIT	XX		XX		XX				XX				XX	
45140304	RACK MTG KIT		XX								XX				
93238906	STATUS PNL KIT	XX	XX					XX	XX	XX	XX			XX	
10126217	SCREW, 6-32X1/4	XX	XX	XX	XX	XX	XX	XX	XX	XX	XX	XX	XX	XX	
47048901	CONN. ADAPTER	XX	XX	XX	XX	XX	XX	XX	XX	XX	XX	XX	XX	XX	
94469421	GROUND CABLE	XX	XX		XX		XX	XX	XX	XX	XX	XX	XX	XX	
10127142	SCREW, 10-32	XX	XX	XX	XX	XX	XX	XX	XX	XX	XX	XX	XX	XX	
10126401	WASHER, LOCK	XX	XX		XX		XX	XX	XX	XX	XX	XX	XX	XX	
92777196	CABLE CLAMP	XX				XX	XX		XX	XX				XX	
47141381	AC CABLE CLAMP		XX								XX				

*SCSI Interface Drives

Table Continued on Next Page

TABLE 4-1. OPTIONAL PARTS (Contd)

PART NO.	PART DESCRIPTION	500 MB* EQUIPMENT PACKAGE 470749xx												
		01	02	03	04	05	06	07	08	09	10	11	12	13
47075101	PA8E1A DRIVE	XX	XX	XX	XX									
47075102	PA8E1B DRIVE					XX	XX	XX	XX					
47075103	PA8E1C DRIVE									XX	XX	XX	XX	
47075104	PA8E1D DRIVE													XX
45070622	POWER SUPPLY	XX	XX	XX	XX	XX	XX	XX	XX	XX	XX	XX	XX	XX
47141391	AC CABLE SHD		XX				XX				XX			
47127502	AC CABLE & FER	XX	XX	XX		XX	XX	XX		XX	XX	XX		XX
75168331	AC CABLE SHORT	XX			XX	XX			XX	XX			XX	XX
47188871	AC CABLE LONG	XX			XX	XX			XX	XX			XX	XX
92588100	DC CABLE	XX	XX	XX	XX	XX	XX	XX	XX	XX	XX	XX	XX	XX
92588104	DC CABLE	XX				XX				XX				XX
15459250	TERM, DIFF, SHD	XX	XX							XX	XX			
15459255	TERM, DIFF, USHD	XX	XX							XX	XX			
15387797	TERM, SE, SHD					XX	XX							XX
15387807	TERM, SE, USHD					XX	XX							XX
47191152	I/O CABLE ASSY	XX	XX			XX	XX			XX	XX			XX
45419405	FAN MTG KIT	XX				XX				XX				XX
45140304	RACK MTG KIT		XX				XX				XX			
93238906	STATUS PNL KIT	XX	XX			XX	XX			XX	XX			XX
10126217	SCREW, 6-32X1/4	XX	XX	XX	XX	XX	XX	XX	XX	XX	XX	XX	XX	XX
47048901	CONN. ADAPTER	XX	XX	XX	XX	XX	XX	XX	XX	XX	XX	XX	XX	XX
94469421	GROUND CABLE	XX	XX	XX	XX	XX	XX	XX	XX	XX	XX	XX	XX	XX
10127142	SCREW, 10-32	XX	XX	XX	XX	XX	XX	XX	XX	XX	XX	XX	XX	XX
10126401	WASHER, LOCK	XX	XX	XX	XX	XX	XX	XX	XX	XX	XX	XX	XX	XX
92777196	CABLE CLAMP	XX			XX	XX			XX	XX			XX	XX
47141381	AC CABLE CLAMP		XX				XX				XX			

*SCSI Interface Drives

Table Continued on Next Page

TABLE 4-2. RECOMMENDED SPARE PARTS

DESCRIPTION/NOTES	PART NUMBER	REPLACE- MENT PART NUMBER
AC POWER CORD (Shielded)	47141391	47141391
AC POWER CORD & FERRITE ASSY (Non-Shielded)	47127502	47127502
AC POWER CORD (Short)	75168331	75168331
AC POWER CORD (Long)	47188871	47188871
CARRIAGE LATCH ELECTROMAGNET KIT ASSEMBLY	47009780	47009781
DC POWER CABLE ASSEMBLY (6.35 cm/2.5 in)	92588100	92588100
DC POWER CABLE ASSEMBLY (1.5 m/5 ft)	92588104	92588109
DC POWER CABLE ASSEMBLY (1.5 m/5 ft)	92588109	92588109
FAN, 24 V dc	46455311	46455311
FILTER, Primary	72852573	72852573
FORMATTED MODULE ASSEMBLY (PA8B1A,B) w/CWBX & Blw	92651500	92651507
w/DWBX & Abv	92651507	92651507
FORMATTED MODULE ASSEMBLY (PA8B1C)	92651511	92651511
FORMATTED MODULE ASSEMBLY (PA8B1D,E)	92651506	92651506
FORMATTED MODULE ASSEMBLY (PA8E1A,B,E)	47032954	47032954
FORMATTED MODULE ASSEMBLY (PA8E1C,D)	47032953	47032953
JUMPER ASSEMBLY, Status/Control & Operator	47001000	47001000
POWER SUPPLY	45070622	45070622

NOTE: Refer to Card Interchangeability Chart (following Table 4-3) for part numbers of component assemblies.

TABLE 4-3. ACCESSORIES

PART NUMBER	DESCRIPTION
12263496	STATIC GROUND WRIST STRAP, 6 1/2 to 8 inch wrist
12263623	STATIC GROUND WRIST STRAP, up to 6 1/2 inch wrist
12263624	STATIC SHIELDING BAG, 5 x 8 inch
12263625	STATIC SHIELDING BAG, 8 x 12 inch
12263626	STATIC SHIELDING BAG, 10 x 12 inch
12263499	STATIC SHIELDING BAG, 14 x 18 inch
12263627	STATIC SHIELDING BAG, 16 x 24 inch
47191151	I/O CABLE, 5 foot (1.5 metre) long
47191152	I/O CABLE, 15 foot (4.5 metre) long
47191153	I/O CABLE, 20 foot (6.1 metre) long
47161154	I/O CABLE, 80 foot (24.5 metre) long
54405700	AVWX I/O CONNECTOR ADAPTER BOARD
15459250	I/O TERMINATOR, Shielded (Differential)
15459255	I/O TERMINATOR, Unshielded (Differential)
15387797	I/O TERMINATOR, Shielded (Single-Ended)
15387807	I/O TERMINATOR, Unshielded (Single-Ended)
24534808	GROUND STRAP (specify length desired)
40125601	GROUND LUG
10126403	LOCKWASHER, #10 (for grounding)

TITLE

USAGE

CONTROL BOARD

COMMON

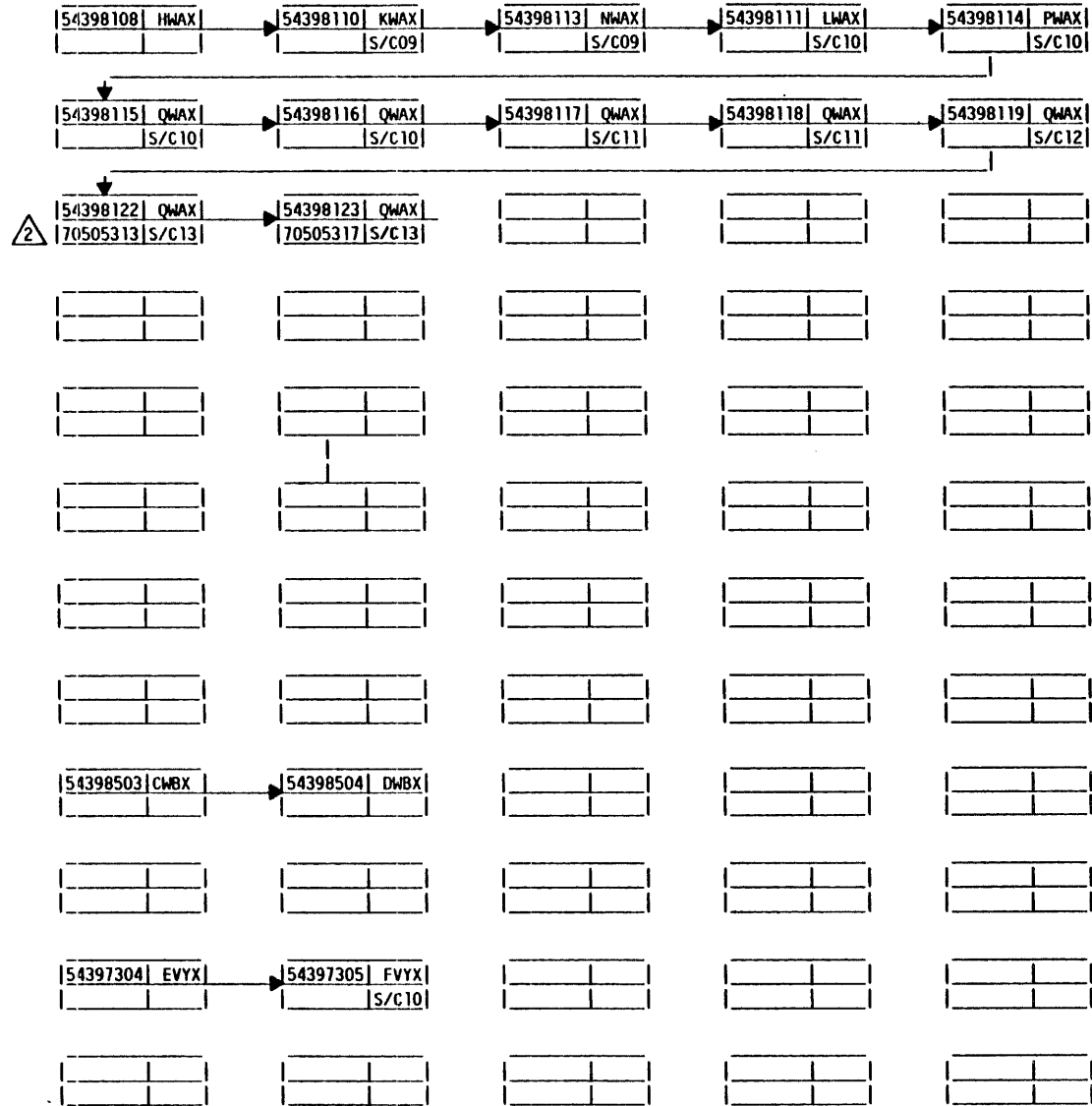

ARM MATRIX BOARD
(IN MODULE)

COMMON

READ/WRITE BOARD

COMMON

TITLE	USAGE				
I/O BOARD	DIFFERENTIAL	54410901	AXJX	54410902	BXJX
					S/C09
		54410903	CXJX	54410904	DXJX
					S/C10
		54410906	FXJX	54410908	FXJX
					S/C10
		54410907	GXJX	54410909	GXJX
			S/C11		S/C11
		54410910	GXJX	54410912	GXJX
			S/C12		S/C12
54410915	GXJX	54410918	GXJX		
	S/C13		S/C13		
I/O BOARD	DIFFERENTIAL PABBIC	54410917	KXJX	54410918	GXJX
					S/C13
		54410920	GXJX		
I/O BOARD	SINGLE ENDED	54411701	AXLX	54411702	BXLX
					S/C10
		54411703	CXLX	54411704	CXLX
					S/C10
		54411704	CXLX	54411705	CXLX
					S/C11
		54411706	CXLX	54411708	CXLX
			S/C13		S/C13
		54411709	CXLX		
OPERATOR PANEL	COMMON	54397702	CVZX	54397703	CVZX
					S/C10
STATUS/CONTROL PANEL	COMMON	54404100	AWRX		

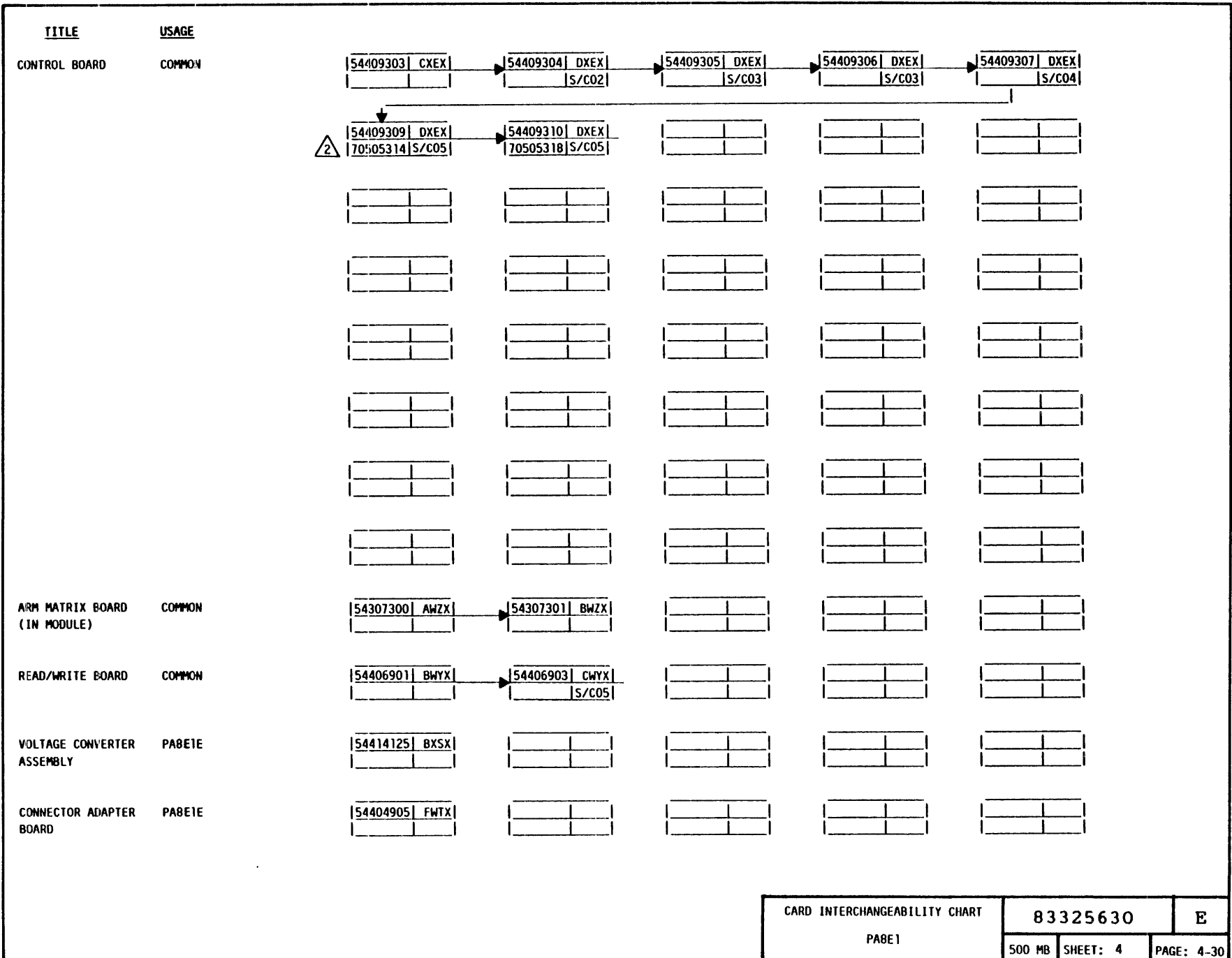

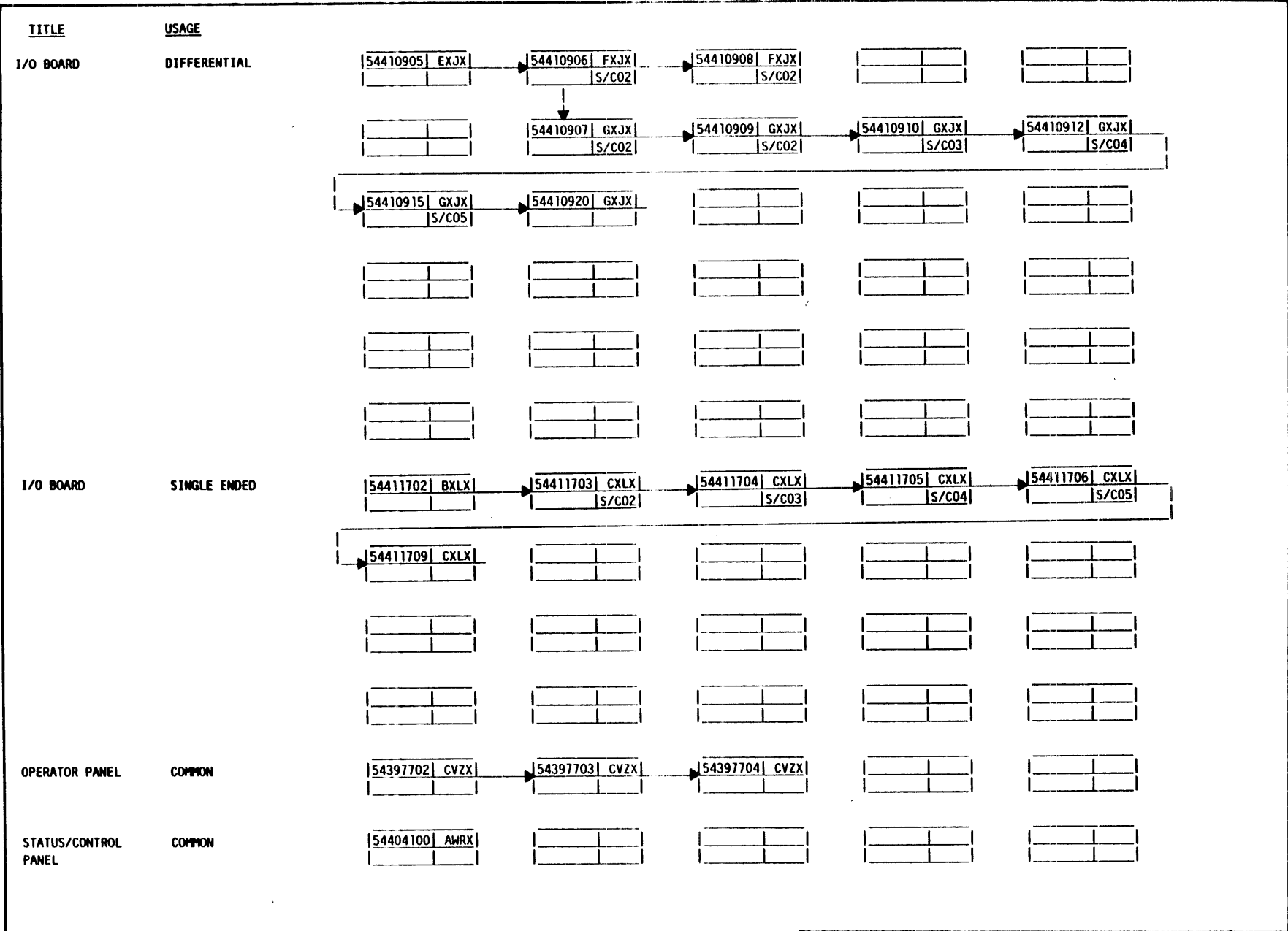

SECTION A

DIAGNOSTIC TESTING AND STATUS CODE SUMMARY

CAUTION

When servicing the drive, observe all precautions listed under Electrostatic Discharge Protection in section 3 of this manual. Failure to observe these precautions can result in serious damage to electronic assemblies.

INTRODUCTION

This appendix describes maintenance-related switches and indicators, how to interpret the information displayed on the status/control panel, and how to select and run the offline diagnostic tests. More complete troubleshooting information can be found in volume 2 of the hardware maintenance manual. You should be familiar with the contents of that manual before doing any troubleshooting.

For trouble analysis, a status/control panel is needed. If the drive installation does not include a status/control panel, we advise that you connect one to the drive for troubleshooting. Refer to section 4 of this manual for part numbers for the status/control panel and its interconnect cable. Section 3 provides instructions for connecting the panel to the drive.

The following types of troubleshooting information are presented in this appendix:

- Switches and Indicators -- describes the switches and indicators used for maintenance.
- Power On Test -- describes the self-tests that occur when dc power is applied to the drive
- Diagnostic Testing -- describes how to use diagnostic testing to isolate drive malfunctions
- Drive Status Codes -- provides information on correcting problems associated with drive power-on/power-off and with servo operation

SWITCHES AND INDICATORS

The offline diagnostic tests are initiated and monitored with the switches and indicators on the status/control panel shown in figure A-1. This panel is located behind the front panel insert. Table A-1 describes the function of the switches and indicators on this panel and the maintenance related indicators located on circuit boards. All operator controls are described in section 2 and all installation related switches are described in section 3.

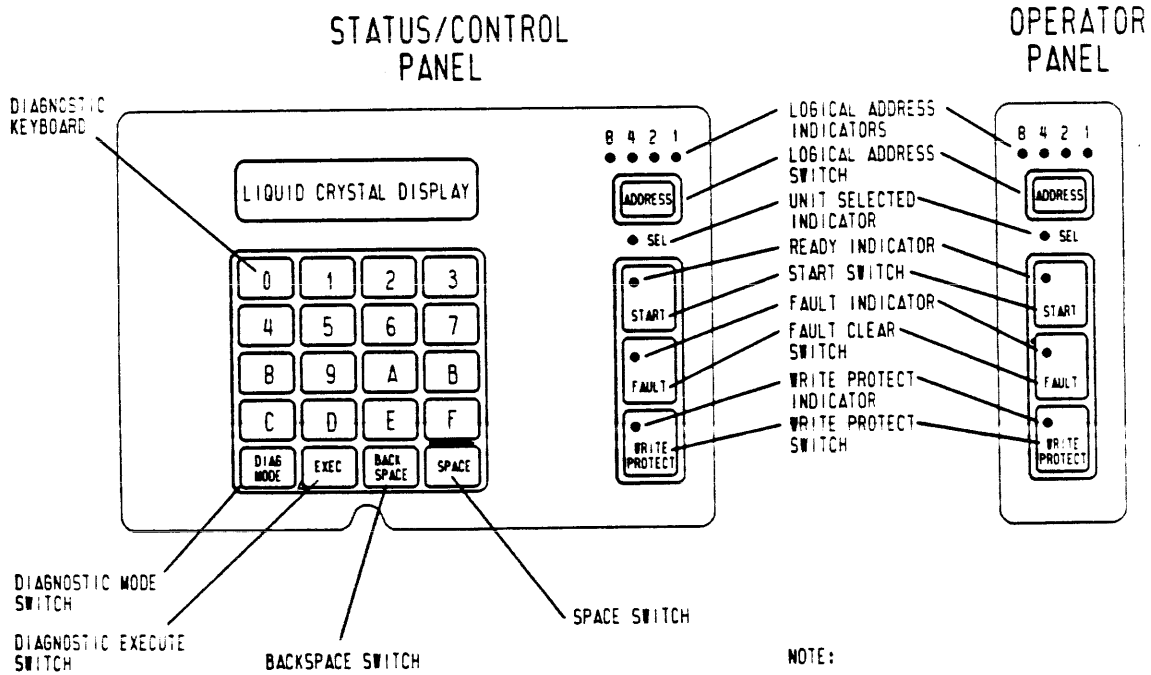
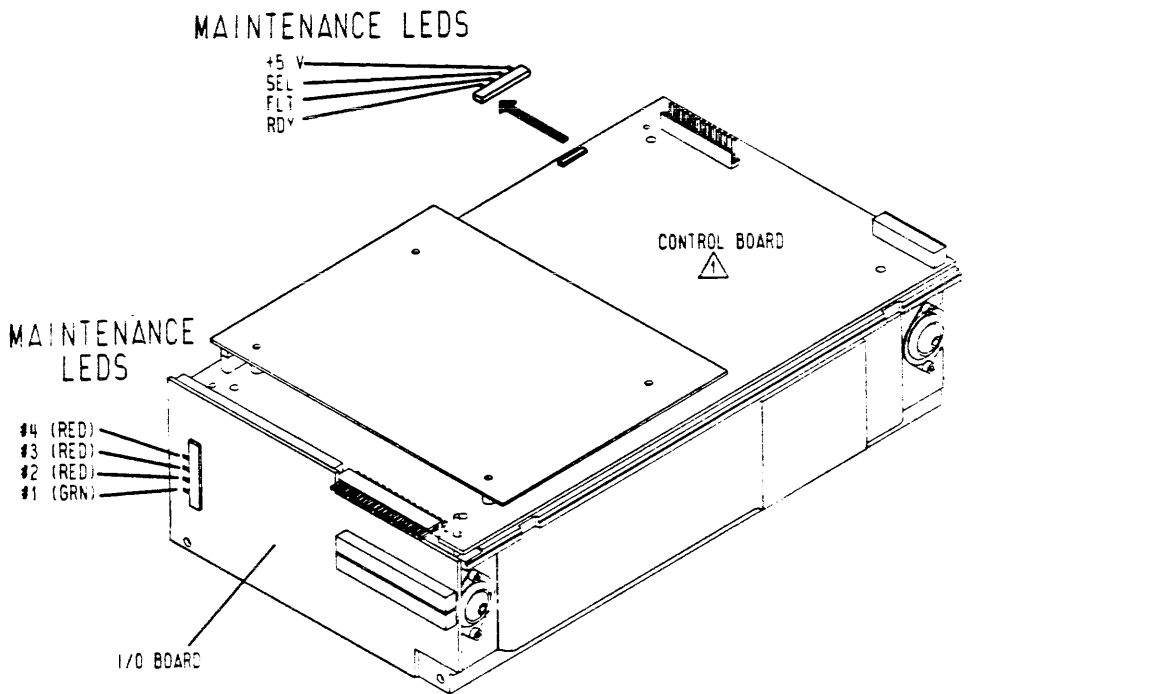

NOTE:
 ⚠ SWITCHES LOCATED ON CIRCUIT BOARDS ARE EXPLAINED IN SECTION 3

11F146B

Figure A-1. Switches and Indicators

TABLE A-1. DRIVE SWITCHES AND INDICATORS

Switch or Indicator	Function
OPERATOR PANEL or STATUS/CONTROL PANEL	
<p>ADDRESS Switch/ Logical Address 8/4/2/1</p> <p>SEL (Selected) Indicator</p> <p>START Switch/ Ready Indicator</p>	<p>Sets the logical address of the drive. It must be held for 2 to 3 seconds to Indicators advance the logical address. Holding it longer increments address continuously. The Logical Address Indicators display the logical address in binary. The address is stored in memory when dc power is removed. The SCSI supports drive logical address 0 only.</p> <p>Indicates the drive is selected by a host.</p> <p>Pressing the START switch starts the power on sequence. The Ready indicator flashes rapidly until the disks are up to speed, the heads are loaded, and no fault conditions exist. The Ready indicator stops flashing but remains lit at the end of the power on cycle.</p> <p>Pressing the START switch again (stop cycle) causes the Ready indicator to flash slowly until disk rotation stops. The current mode (start/stop) is stored in memory when dc power is removed.</p>
Table Continued on Next Page	

TABLE A-1. DRIVE SWITCHES AND INDICATORS (Contd)

Switch or Indicator	Function
OPERATOR PANEL or STATUS/CONTROL PANEL (Contd)	
<p>FAULT Indicator/ Fault Clear Switch</p> <p>WRITE PROTECT Switch/Indicator</p>	<p>The FAULT indicator is inside the Fault Clear switch. It lights if a fault exists within the drive. It is turned off by any of the following (provided the error condition no longer exists):</p> <ul style="list-style-type: none"> • Pressing the Fault clear switch • Fault Clear command from the host • A drive power up operation <p>Operation of the WRITE PROTECT or Write Protect maintenance switch on the control board prevents write operation and lights the Write Protect indicator. The current position of the WRITE PROTECT switch is stored in memory when dc power is removed.</p>
STATUS/CONTROL PANEL ONLY	
<p>Diagnostic Keyboard</p> <p>Liquid Crystal Display</p> <p>DIAG MODE (Diagnostic Mode) Switch</p> <p>SPACE and BACK SPACE Switches</p> <p>EXEC (Execute) Switch</p>	<p>Used to enter diagnostic tests and parameters.</p> <p>Displays drive status, faults, and current cylinder address.</p> <p>Places drive in diagnostic mode and disables the I/O.</p> <p>Used to enter the desired diagnostic tests.</p> <p>Starts and stops diagnostic tests.</p>
Table Continued on Next Page	

TABLE A-1. DRIVE SWITCHES AND INDICATORS (Contd)

Switch or Indicator	Function
CONTROL BOARD	
<p>Maintenance LEDs</p> <p>+5 V Indicator</p> <p>SEL Indicator</p> <p>RDY Indicator</p> <p>FLT Indicator</p>	<p>Provide indications of drive status when the operator panel or status/control panel is not used.</p> <p>Indicates presence of +5 V.</p> <p>Indicates the drive is selected by a host.</p> <p>Indicates the drive is ready (spindle power up is complete, heads are loaded, and no fault conditions exist).</p> <p>Indicates a fault exists within the drive.</p>
I/O BOARD	
<p>Self-Test Switch (DIP SW1)</p> <p>Power On Sequence Switch (DIP SW3)</p> <p>LEDs (1 green, 3 red)</p> <p>Manual Reset Switch (DIP SW4)</p>	<p>Controller diagnostic looping occurs when this switch is set to the on (closed) position. This switch is set at the factory to the off (open) position.</p> <p>In the on (closed) position, this switch allows immediate spindle power up when the START switch is pressed. In the off (open) position, the spindle power up sequence begins when dc power is applied.</p> <p>Indicate controller test failure status. Refer to I/O Board Light Emitting Diodes in this section.</p> <p>Momentarily placing this switch in the on (closed) position resets the SCSI. This feature is normally used during maintenance only. The switch is factory set to its off (open) position.</p>

POWER ON TESTING

Two power on test sequences occur as dc power is applied to the drive. The SCSI controller (I/O board) firmware is tested and initialized first. This is not an exhaustive diagnostic test but it verifies the integrity of the major components. The drive firmware is initialized if SCSI firmware testing and initialization is successful.

SCSI I/O BOARD INITIALIZATION

Two power on test sequences occur as dc power is applied to the drive. The SCSI controller (I/O board) firmware is tested and initialized first. This is not an exhaustive diagnostic test but it verifies the integrity of the major components. The drive firmware is initialized if SCSI firmware testing and initialization are successful.

Controller testing consists of a hardware self-test that verifies the integrity of the controller hardware. The controller halts further initialization if this test fails.

The initialization sequence occurs under any of the following three conditions:

- Controller (I/O) power-up sequence occurs
- SCSI Bus Reset (-RST signal is asserted)
- BUS DEVICE RESET message is received on SCSI Bus

The controller does not respond to a Selection Phase on the SCSI Bus during the self-test sequence. The self-test sequence consists of the following events:

- Test Microprocessor
- Test Buffer Controller
- Test RAM Memory
- Test SCSI Interface

The SCSI firmware initialization sequence is as follows:

- Set status for the LUN (logical unit number) to Busy
- Initialize the SCSI

The drive firmware initialization sequence occurs next and is as follows:

- Initialize disk interface (I/O board-to-drive)
- Initialize LUN parameters
- Start the drive spindle (only during power on sequence)
- Read parameters from cylinder 0, sector 0 of the drive (only during power on sequence)

- Test controller/drive interface (only during power on sequence)
- Do write/read test on diagnostic cylinder (only during power on sequence)

When the SCSI controller firmware is initialized, the controller will respond to a Selection Phase. It returns BUSY status until the entire drive initialization process is complete.

The drive initialization firmware spins-up the drive, and it attempts to read the saved controller parameters from a reserved area of the drive. These parameters define the disk characteristics and other operating parameters. As part of a power on sequence, drive initialization concludes with the following tests:

- Test controller/drive interface
- Do write/read test on diagnostic cylinder (2 patterns)

Errors during these tests cause the I/O LEDs to flash (as explained in the maintenance manual) and the drive will no longer respond to SCSI commands. A SCSI reset aborts the error indication and any further diagnostic testing, and it will complete the initialization sequence.

Inquiry Command

The INQUIRY command requests the characteristics of the target (drive) be sent to the Initiator. The INQUIRY command data consists of a five-byte header followed by the product characteristics as shown in table A-2.

TABLE A-2. INQUIRY DATA

Byte/Bit	7	6	5	4	3	2	1	0
0	Peripheral Device Type (00)							
1	0	Device Type Qualifier						(00)
2	0	0	ECMA Version (0)			ANSI Version (1)		
3	0	0	0	0	0	0	0	1
4	Additional Length (1FH)							
5	Reserved							(00H)
6	Reserved							(00H)
7	Reserved							(00H)
8	Vendor Identification				ASCII C		(43H)	
9	Vendor Identification				ASCII D		(44H)	
10	Vendor Identification				ASCII C		(43H)	
11	Vendor Identification				ASCII blank		(20H)	
12	Vendor Identification				ASCII blank		(20H)	
13	Vendor Identification				ASCII blank		(20H)	
14	Vendor Identification				ASCII blank		(20H)	
15	Vendor Identification				ASCII blank		(20H)	
Table Continued on Next Page								

TABLE A-2. INQUIRY DATA (Contd)

Byte/Bit	7	6	5	4	3	2	1	0
16	Product Identification				ASCII E		(45H)	
17	Product Identification				ASCII M		(4DH)	
18	Product Identification				ASCII D		(44H)	
19	Product Identification				ASCII blank		(20H)	
20	Product Identification				ASCII 9		(39H)	
21	Product Identification				ASCII 7		(37H)	
22	Product Identification				ASCII 2		(32H)	
23	Product Identification				ASCII 0		(30H)	
24	Product Identification				ASCII 1		(31H)	
25	Product Identification				ASCII blank		(20H)	
26	Product Identification				ASCII ((28H)	
27*	Product Identification				ASCII 3/5		(33/35H)	
28*	Product Identification				ASCII 6/0		(36/30H)	
29*	Product Identification				ASCII 8/0		(38/30H)	
30	Product Identification				ASCII)		(29H)	
31	Product Identification				ASCII blank		(20H)	
32	Revision Number				ASCII blank		(20H)	
33	Revision Number				ASCII blank		(20H)	
34**	Revision Number				First ASCII #		(xxH)	
35**	Revision Number				Second ASCII #		(xxH)	
*This byte can contain either value.								
**These two bytes indicate two-digit microcode revision.								

Receive Diagnostic Results Command

The RECEIVE DIAGNOSTIC RESULTS command requests that analysis data be sent to the initiator following completion of a SEND DIAGNOSTICS command. Diagnostic data return bytes are shown in table A-3.

TABLE A-3. DIAGNOSTIC DATA RETURN BYTES

Byte	Description
0	Additional Length (MSB)
1	Additional Length (LSB)
2	FRU Code (Most probable)
3	FRU Code
4	FRU Code
5	FRU Code (Least probable)
6	Error Code (MSB)
7	Error Code (LSB)

Additional Length Bytes

This two-byte value indicates the number of additional bytes included in the diagnostic data list. This value can be 0000H or 0006H. A value of 0000H means that there are no additional bytes. A value of 0006H means there are six additional bytes (bytes 2-7).

FRU Code

The FRU code byte identifies the assembly that may have failed. The codes are listed in probability order with the most probable assembly listed first and the least probable listed last. FRU codes are shown in table A-4. These codes should not be confused with the FRU codes reported during the drive off-line tests.

Error Code

This two-byte value provides information about what part of the diagnostic operation has failed. The error codes are shown in table A-5.

TABLE A-4. ONLINE FRU CODES

Code	Description
00H	No FRU Information Available
01H	Replace Entire Unit
02H	Control Board
03H	Module
04H	Power Supply
05H	SCSI I/O Board
06H	R/W Board
07H	Carriage Latch Electromagnet

TABLE A-5. ERROR CODES

Code	Description
01H	SCSI controller external memory test (600H - AFFFH)
02H	Buffer controller register test
03H	Disk formatter register test
04H	SCSI chip test
05H	Test Drive Ready
06H	Drive on-line test (diagnostic cylinder write/verify)
07H	No drive response for self-test command
46H	Seek time-out status
4BH	Off-track seek error status
4DH	Illegal cylinder address status
4FH	Seek error on settle-in status
50H	Low Vcc glitch recovery (speed >2400 r/min)
51H	Control MPU hang reset (speed >2400 r/min)
54H	First seek fault on retract
55H	First seek fault on load
56H	First seek fault on RTZ
57H	First seek fault on calibrate
58H	Speed loss status
59H	Motor cannot start due to error status
5AH	Emergency retract status
60H	Motor MPU fail status
61H	Servo MPU fail status
90H thru DOH	CDIC register test

READING THE I/O BOARD LEDS

Four light emitting diodes (3 red, 1 green) are visible on the I/O board at the rear of the drive. The LEDs show various SCSI controller conditions. Any one or a combination of LEDs can be on, off, or flashing to indicate a specific condition. Any indication other than heartbeat, command executing, or retry is an error condition. The corrective action for any error is to replace the I/O board. The indications are valid only if a terminator is installed and terminator power is applied.

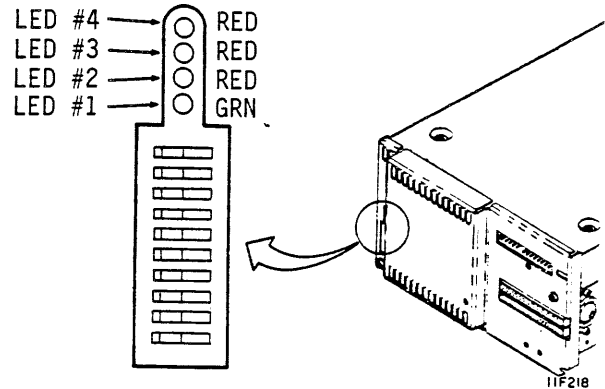

The "Heartbeat" Display

LED #3 on and LED #1 flashing indicates there is no activity and the unit is available. The flashing green LED #1 serves as a "heartbeat" indication.

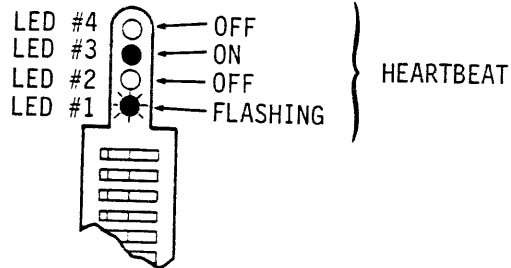

11F219

Self-Test Failure Indication

All four LEDs form a binary display showing which self-test failed. The range of test numbers is 0 - F and the corrective action for all self-test failures is to replace the SCSI controller (I/O board).

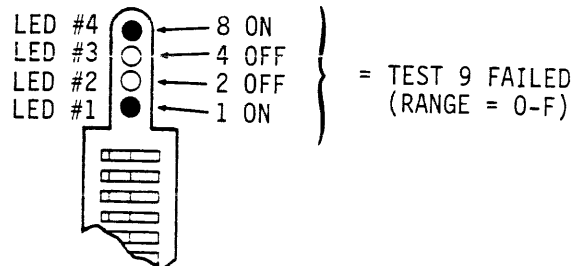

11F220

The Command Executing Display

When the green LED (#1) is flashing and all others are off, a command is executing and the drive is not available.

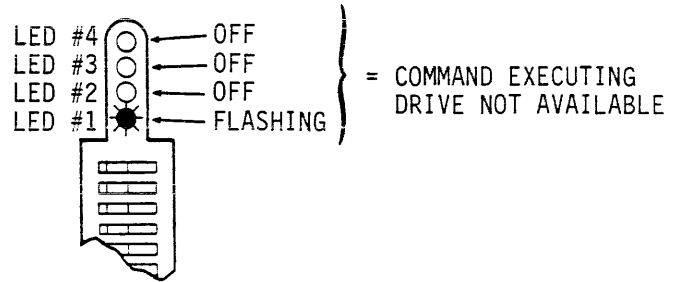

11F221

The Retry Display

If all except the green LED are on, a read or write retry is occurring.

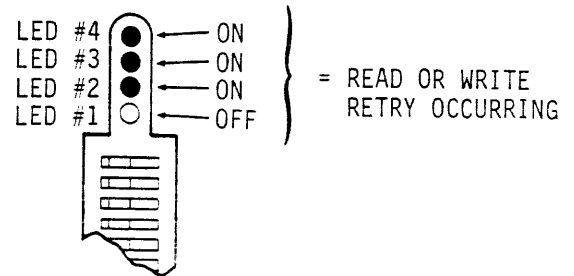

11F222

The CDIC Failure Display

A controller-device interface chip failure has occurred if all LEDs are flashing at two second intervals.

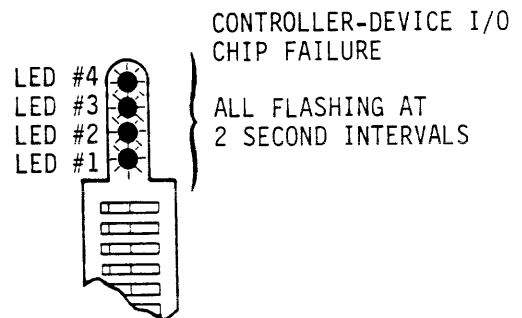

11F223

The Unrecoverable System Error Display

The failing I/O microcode address for an unrecoverable system error is indicated in a sequence of eight displays. Four of the displays represent the 16-bit failing microcode address. The other four displays identify the particular four-bit segment of the 16-bit address.

Displaying the First Four Bits of Failing Microcode Address

LED #1 (green) on and all others off means the next display represents the first four bits of failing microcode address for an unrecoverable system error. The LEDs remain off for one second before going to the next sequence.

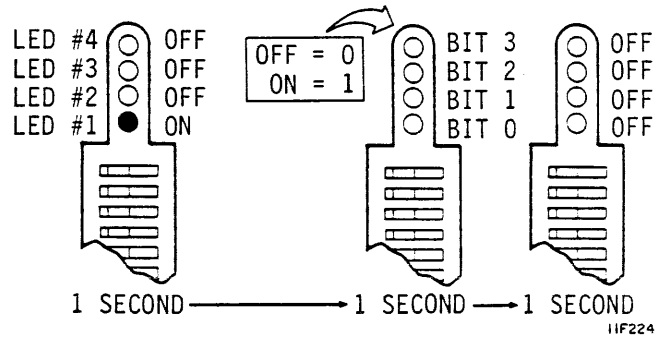

Displaying the Second Four Bits of Failing Microcode Address

LED #2 on and all others off means the next display shows the second four bits of failing microcode address for an unrecoverable system error. The LEDs remain off for one second before going to the next sequence.

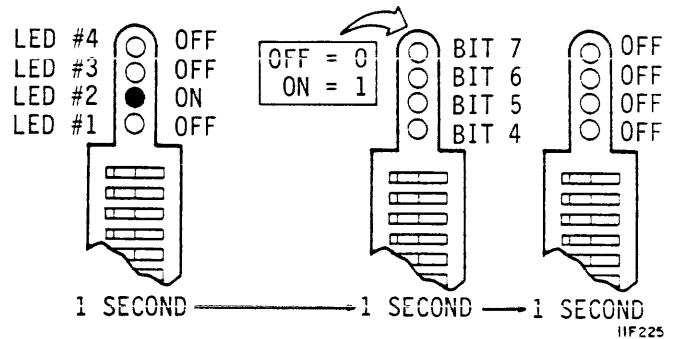

Displaying the Third Four Bits of Failing Microcode Address

LEDs #1 and #2 on and all others off means the next display shows the third four bits of failing microcode address for an unrecoverable system error. The LEDs remain off for one second before going to the next sequence.

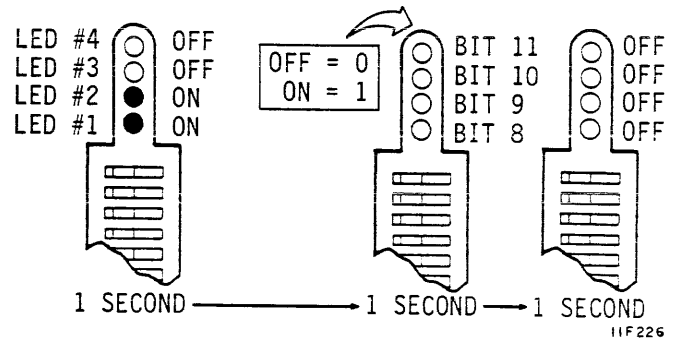

Displaying the Last Four Bits of Failing Microcode Address

LED #3 on and all others off means the next display shows the last four bits of the failing microcode address for an unrecoverable system error. The LEDs remain off for one second before going to the next sequence.

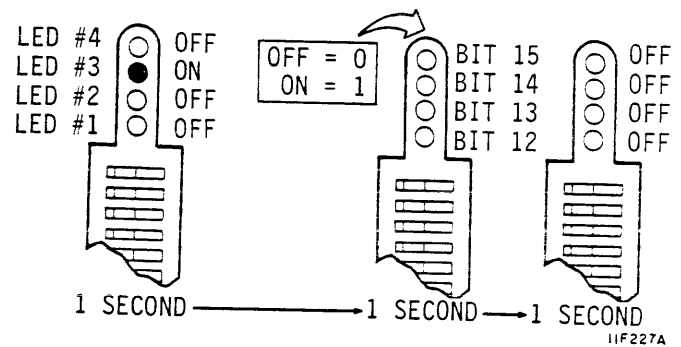

Displaying Write/Read Test Failure

LEDs 3 and 4 flash alternately with 1 and 2 to indicate a write/read test failure on the diagnostic cylinder.

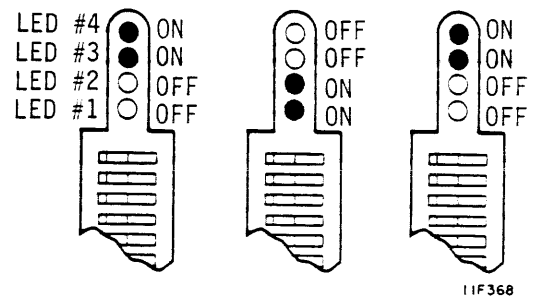

DRIVE TESTING

When dc power is applied to the drive, the Control MPU performs a series of self-tests. During these tests the Address, Ready, FAULT, and WRITE PROTECT lights on the status/control panel or operator panel will be lit. After approximately four seconds, the FAULT light will go off, indicating successful completion of the self-tests. The drive failed the power-on self-test if the Ready and FAULT lights remain on constantly. The Address lights indicate which self-test routine the drive failed to complete. Refer to table A-6 to determine which test failed and what action to take.

In addition to the individual tests listed in table A-6, the Control MPU attempts to communicate with the status/control panel. If this communication is unsuccessful, the Control MPU displays the message PANEL FAILURE on the LCD of the panel.

DIAGNOSTIC TESTING

The drive's offline diagnostics are initiated and monitored via the keyboard and LCD of the status/control panel. Refer to the beginning of this appendix for information on the switches and indicators on the panel.

TEST SELECTION PROCEDURE

To run offline diagnostic tests on the drive, place the drive in diagnostic mode and select the tests desired. To do this:

- Press the DIAG MODE switch to enter diagnostic mode and observe that the LCD reads DIAG TEST XX.
- Enter two hexadecimal characters on the keyboard and press EXEC switch to select the first test.

Directions for running the individual diagnostic tests appear later in this section. When the Execute switch is pressed one more time, the test ends and the LCD again reads DIAG TEST XX. At this point you have two choices:

- Enter two hexadecimal characters on the keyboard and press EXEC switch to select another test, or
- Press the DIAG MODE switch to leave diagnostic mode and observe that the LCD displays drive operating status.

TABLE A-6. POWER ON TEST FAILURE

Address Lights*				Hex Code	Test Failed** & Actions
8	4	2	1		
•	•	•	•	F	<u>RAM Test</u> Action: 1. Replace control board.
•	•	•	o	E	<u>ROM Test</u> Action: 1. Replace control board.
•	•	o	•	D	<u>I/O Chip Test</u> Actions: 1. Replace I/O board. 2. Replace control board.
•	•	o	o	C	<u>Peripheral Chip (Test 1)</u> Action: 1. Replace control board.
•	o	•	•	B	<u>Peripheral Chip (Test 2)</u> Action: 1. Replace control board.
•	o	•	o	A	<u>Motor MPU Test</u> Action: 1. Replace control board.

* Darkened circles indicate light is On.

**Ready and FAULT lights remain on constantly, indicating drive failed four second power-on self-test.

TEST DESCRIPTIONS

Test 00 -- Display Drive Operating Status Log

This test displays the eight most recently generated drive status codes. After test selection, the display provides a hexadecimal status code from the internal log. This code is preceded by a character (0-7) and a colon, indicating the position of the status code in the status log. To execute test 00, perform the following steps:

1. Enter Test 00, then press EXEC switch. The LCD will display DRIVE LOG: 0:XX where the number 0 indicates the position in the log and XX represents the status code entered in that position.
2. Press SPACE switch repeatedly until you see a code preceded by an asterisk (for example, DRIVE LOG: *5:XX). The asterisk identifies that code as the most recent entry in the status log.
3. Use the SPACE switch to step through from the 8th most recent to the most recent status.
4. Press EXEC switch to end the test and return to test selection.

Test 01 -- Display Fault Log

This test displays the eight most recently stored fault codes. After test selection, a hexadecimal fault code will be displayed. This code is preceded by a character (0-7) and a colon, indicating the position of the fault code in the fault log. To execute test 01, perform the following steps:

1. Enter Test 01, then press EXEC switch. The LCD will display FAULT LOG: 0:XX where the number 0 indicates the position in the log and XX represents the fault code entered in that position.
2. Press SPACE switch repeatedly until you see a code preceded by an asterisk (for example, FAULT LOG: *5:XX). The asterisk identifies that code as the most recent entry in the fault log.
3. Use the SPACE switch to step through from the 8th most recent to the most recent fault.

4. If more than one fault occurs simultaneously (multiple faults), more than one bit in the fault code will be set. Check the bit-mapped locations of each fault by referring to the following list:

<u>Bit</u>		<u>Definition</u>
0	(LSB)	Read•Write Fault (01)
1		(Read+Write)•Off Cylinder Fault (02)
2		First Seek Fault (04)
3		Write Fault (08)
4		Write•Write Protected Fault (10)
5		Head Select Fault (20)
6		Voltage Fault (40)
7	(MSB)	Not Used (80)

5. Press EXEC switch to end the test and return to test selection.

Test 04 -- Calculate Three Most Likely Field Replaceable Units

NOTE

Do not execute Tests 05, 06, or 07 prior to running Test 04.

This test uses the fault status and the drive operating status history (Tests 00 and 01) to predict the most likely cause of drive failure. Table A-8 lists the individual codes and their corresponding replacement part. To execute Test 04, perform the following steps:

1. Enter Test 04, then press EXEC switch. The LCD will display FRUS: XX XX XX. Upon test completion, the three field replaceable units will be displayed, with the first hexadecimal code being the most likely cause of the failure.
2. Press EXEC switch to end the test and return to test selection.

TABLE A-7. OFFLINE FRU CODES

Code	Description
00H	No FRU Information
01H	Control Board
02H	Module
03H	Power Supply
04H	I/O Board
05H	Read/Write Board
06H	Carriage Latch Electromagnet

Test 05 -- Servo Test

This test clears both the drive status log and fault log. Because Test 04 relies on status history that would be cleared by Test 05, you might want to run Test 04 before running Test 05. Test 05 automatically performs several types of seek operations. They are as follows:

<u>Operation</u>	<u>Number Of Times Executed</u>
RTZ	1
1 Track Seek	16
RTZ	1
Partial Servo Recalibrate	1
RTZ	1
Maximum Length Seek	16
RTZ	1

Execution stops when an error is detected or the test completes. To execute Test 05, perform the following steps:

1. Enter Test 05, then press EXEC switch. Upon successful completion of the test, the LCD will display OK, CYL: 000. If an error occurs, the LCD will display SERVO ERROR: XX. Drive status codes (servo errors) are defined in table A-8 at the end of this section.
2. Press EXEC switch to end the test and return to test selection.

Test 06 -- Clear Drive Operating Status Log

This test clears the drive status log resident in program RAM. Because Test 04 relies on status history that would be cleared by Test 06, you might want to run Test 04 before running Test 06. To execute Test 06, perform the following steps:

1. Enter Test 06 and press EXEC switch. The LCD will display DRIVE LOG CLEAR.
2. Press EXEC switch to end the test and return to test selection.

Test 07 -- Clear Fault Log

This test clears the fault log. Because Test 04 relies on status history that would be cleared by Test 07, you might want to run Test 04 before running Test 07. To execute Test 07, perform the following steps:

1. Enter Test 07 and press EXEC switch. The LCD will display FAULT LOG CLEAR.
2. Press EXEC switch to end the test and return to test selection.

Test 08 -- Direct Or Continuous Seeks

This test performs direct or continuous seeks between cylinder 0 and the desired cylinder address. The operation stops if an error occurs or if the EXEC switch is pressed. To execute Test 08, perform the following steps:

1. Enter Test 08 and press EXEC switch.
2. The display HEX CYL XXX asks you to supply a valid destination address (between 0 and 4C0 inclusive). Enter three characters and press SPACE switch.
3. The display DIR OR CONT? D/C asks you to select either DIRECT (D) or CONTInuous (C) seeks. Enter either C or D to start test.
4. If D was entered and the direct seek was successful, the LCD will display OK, CYL: XXX, where XXX is the destination address previously entered. Press EXEC switch to end the test and return to test selection.

5. If either D or C was entered and an error occurs, the LCD will display SERVO ERROR: XX. Drive status codes (servo errors) are defined in table A-8 at the end of this section. By running Test 05 or Test 0E, you can clear the seek error.
6. If C was entered, press EXEC switch to end the test and return to test selection.

Test 09 -- Random Seek

This test performs random seeks between cylinders 0 and 1216 (maximum cylinder address). Operation stops if an error occurs or if the EXEC switch is pressed. To execute Test 09, perform the following steps:

1. Enter Test 09 and press EXEC switch.
2. The LCD will display OK, CYL: XXX if execution was successful.
3. If an error occurs during the test, the LCD will display SERVO ERROR: XX. Drive status codes (servo errors) are defined in table A-8 at the end of this section.
4. Press EXEC switch to end the test and return to test selection.

Test 0C -- Display EPROM Part Number

This test displays the 8-digit part number of the control microprocessor EPROM. To execute Test 0C, perform the following steps:

1. Enter Test 0C and press EXEC switch. The LCD will display the 8-digit part number of the EPROM as follows:
EPROM # = 12345678.
2. Press EXEC switch to end the test and return to test selection.

Test 0E -- Return To Zero

This test initiates a return to zero command. To execute Test 0E, perform the following steps:

1. Enter Test 0E and press EXEC switch. The LCD will display OK, CYL: 000.

2. If an error occurs during the test, the LCD will display SERVO ERROR: XX. Drive status codes (servo errors) are defined in table A-8 at the end of this section.
3. Press EXEC switch to end the test and return to test selection.

Test 2F -- I/O Test

This test causes the I/O MPU to run a self-test of the I/O circuitry. To execute Test 2F, perform the following steps:

1. Enter Test 2F and press EXEC switch.
2. If an error occurs during the test, the LCD will display SCSI CM:2F ST:28.
3. If the test runs error-free, the LCD will display SCSI CM:2F ST:18.
4. Press EXEC switch to end the test and return to test selection.

DRIVE STATUS CODES

Whenever the drive is in a power on condition (dc power active), the Control MPU is periodically checking the operation of the drive and generating appropriate operating status codes.

Table A-8 lists the status codes and a definition of each code. If a drive malfunction occurs, observe the error code and perform Diagnostic Test 04 to calculate the action to be taken.

Figure A-2 shows an example of the LCD during normal operation and when a fault occurs. During normal operation, the LCD displays current drive status, current cylinder address, and which drive channel is selected or reserved. This is a single-channel drive so the display always shows channel 1 being selected or reserved.

If a fault occurs, the LCD displays the type of fault(s) that occurred along with the current drive status. If more than one fault occurred, use the SPACE switch to step through the fault log to determine what faults are present.

Pressing the Fault Clear switch on the status/control panel clears the LCD fault display and the FAULT indicator, provided that the fault condition is no longer present. However, a Fault Clear signal from the initiator clears only the FAULT indicator.

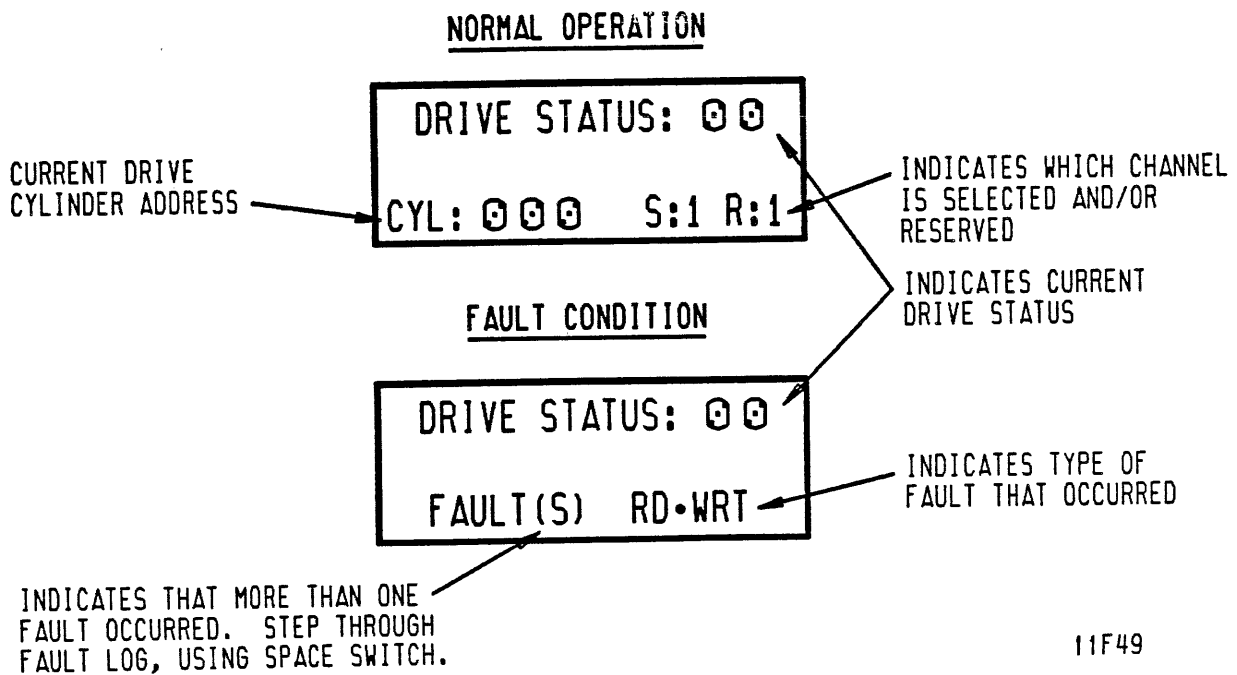

Figure A-2. Example of LCD (Liquid Crystal Display)

TABLE A-8. DRIVE STATUS CODES

Code	Title	Description
NORMAL START/STOP STATUS		
00	Ready & On Cylinder	Indicates that the drive is on cylinder and ready to perform normal operations.
02	Motor Stopping	Indicates that the motor is coasting down or that motor braking is in progress.
03	Motor Stopped	Indicates that the motor is stopped.
Table Continued on Next Page		

TABLE A-8. DRIVE STATUS CODES (Contd)

Code	Title	Description
NORMAL START/STOP STATUS (Contd)		
04	First Load/Calibrate	Indicates that the heads are moving from the landing zone to track 0 and servo calibration is being performed.
05	Sequence Delay	This code should never appear because the drive address is always set to zero.
06	START Switch Pressed and Waiting for Power Sequence Signals	Indicates the START switch was pressed and the drive is waiting for the SCSI controller to complete its timeout.
07	Starting Motor	Indicates that start conditions are present and that the spindle motor is starting.
08	Motor Up To Speed	Indicates that the spindle motor has reached full speed.
I/O BOARD NORMAL STATUS		
09	I/O Self-Test Passed	I/O MPU ran and passed its power on initialization self-test.
SWEEP CYCLE STATUS		
0A	Drive in Sweep Segment	The drive is running a series of seeks for a sweep cycle.
0B	Heads Left on Last Cylinder of Sweep	Current head position determined by last sweep cycle -- not by a controller-requested seek.
Table Continued on Next Page		

TABLE A-8. DRIVE STATUS CODES (Contd)

Code	Title	Description
SEEK ERROR STATUS		
46	Seek Timeout	Indicates that during a normal seek the drive took longer than 100 milliseconds to reach on cylinder.
4B	Off Track Seek Error	Indicates that either the drive failed to stay on cylinder or cylinder pulses were detected during track-following.
4D	Illegal Cylinder Address	Indicates that during a normal seek, the controller issued too high a cylinder address (greater than 1216).
4F	Seek Error On Settle In	Indicates that the drive could not settle in on the destination cylinder.
CONTROL MPU ERRORS (reported on older drives)		
50	Low Vcc Glitch	Indicates that the Control MPU was reset and that DC Master Clear is active due to Low Vcc (power loss).
51	Control MPU Reset	Indicates that the Control MPU was reset due to a hang condition.
Table Continued on Next Page		

TABLE A-8. DRIVE STATUS CODES (Contd)

Code	Title	Description
FIRST SEEK FAULT STATUS		
54	First Seek Fault On Retract	Indicates that the drive failed to complete the retract portion of the first seek.
55	First Seek Fault On Load	Indicates that the drive failed to load the heads.
56	First Seek Fault On RTZ	Indicates that the drive failed to complete the return to zero (RTZ) portion of the first seek.
57	First Seek Fault On Calibrate	Indicates that the drive did not complete the velocity calibration operation.
ERROR CONDITION STATUS		
58	Speed Loss	Indicates that the spindle speed fell below 3564 r/min. When this happens, the drive activates the Write Protect line, drops the Ready signal, and performs a retract operation.
59	Motor Can't Start Due to Error	Indicates a problem in the motor control circuitry.
5A	Emergency Retract	Indicates that the heads retracted to the landing zone due to a power loss (-Low Vcc active), or that a servo-controlled retract failed.
Table Continued on Next Page		

TABLE A-8. DRIVE STATUS CODES (Contd)

Code	Title	Description
MOTOR AND SERVO MPU ERRORS		
60	Motor MPU Failure	Indicates that the Control MPU was unable to communicate with the Motor MPU.
61	Servo MPU Failure	Indicates that the Control MPU was unable to communicate with the Servo MPU.
I/O BOARD ERROR STATUS		
62	I/O Status Transfer Failed	The I/O MPU failed to transfer status successfully to the Control MPU during a diagnostic test.
6E	I/O Self-Test Failed	The I/O MPU failed its power on initialization self-test.

ANHANG B

INSTALLATIONS- UND BETRIEBSERFORDERNISSE

EINLEITUNG

Dieser Anhang enthält Informationen für gefahrlose(n) Anschluß, Betrieb und Wartung des Laufwerks.

SICHERHEITSHINWEISE

- Um die Zuverlässigkeit der im Laufwerk eingebauten Sicherheitseinrichtungen zu gewährleisten, darf die Installation und Wartung des Gerätes nur von qualifiziertem Wartungspersonal unter Verwendung von Original-Imprimis-Ersatzteilen durchgeführt werden.
- Beim Ausbrechen von Feuer oder in anderen Notfällen ist die Verbindung zum Hauptstromnetz durch das Ziehen des Netzsteckers aus der Steckdose zu unterbrechen. Sollte dies nicht möglich oder unpraktisch sein, so ist der Hauptstromunterbrecher des Systems zu bedienen, um die Laufwerke vom Hauptstromnetz zu trennen.
- Wenn das Laufwerk in einem Geräteeinschub oder Gehäuse montiert ist, versichern Sie sich, daß die Temperatur im Einschub oder Gehäuse die in diesem Handbuch festgelegten Werte nicht überschreitet. Sind Geräte übereinander angeordnet, achten Sie besonders auf das obere Gerät, da dort die Temperatur gewöhnlich am höchsten ist.
- Das Gerät ist konstruiert zum Anschluß und Betrieb in Übereinstimmung mit IEC380, IEC435, VDE0805 und VDE0806.
- Geräteschalter schaltet nur die Sekundärseite des Netzgerätes. Schalterstellung 1: Normal- und Ersatzgerät ist eingeschaltet. Schalterstellung 0: Normal- und Ersatzgerät ist ausgeschaltet. Vorsicht: in beiden schalterstellungen liegt die Netzspannung an den Geräten an.
- Falls das Netzteil an ein IT-Netzwerk angeschlossen wird, ist die Eingangsspannung auf 230 V zu begrenzen.
- Das Netzteil ist nicht im feld reparierbar. Versuchen Sie deshalb nicht, es zu zerlegen. Im Falle eines Defekts ist es komplett auszutauschen.

- Falls kein empfohlenes Imprimis Netzgerät verwendet wird, stellen Sie bitte sicher, daß das Netzgerät den Spezifikationen in diesem Manual entspricht und konstruiert ist für den Betrieb entsprechend IEC380, IEC435, VDE805 und VDE806.

ANSCHLUSS-ERFORDERNISSE

Der Installationsort muß dem in den folgenden Tabellen und Skizzen dargelegten Vorschriften entsprechen:

TABELLE B-1. UMGEBUNGSBEDINGUNGEN

<u>TEMPERATUR</u>	<u>BEREICH</u>	<u>MAX. ÄNDERUNGSWERT</u>
Lagerung (verpackt)	-10 bis 50°C	15°C / h
Transit (verpackt)	-40 bis 60°C	20°C / h
in Betrieb	10 bis 45°C	15°C / h
<u>RELATIVE FEUCHTE</u>		
Lagerung (verpackt)	5% bis 95% (keine Kondensation erlaubt)	
Transit (verpackt)	5% bis 95% (keine Kondensation erlaubt)	
in Betrieb	20% bis 80% (keine Kondensation erlaubt)	
<u>ATMOSPHÄRENDRUCK</u>		
Lagerung (verpackt)	-305 m bis 3000 m oder 104 kPa bis 69 kPa	
Transit (verpackt)	-305 m bis 12 192 m oder 104 kPa bis 19 kPa	
in Betrieb	-305 m bis 3000 m oder 104 kPa bis 69 kPa	

TABELLE B-2. ERFORDERNISSE FÜR EL. ANSCHLUSS

SPEZIFIKATION	WERTE	
	100 - 120 V ac	208 - 240 V ac
Spannungsbereich	85 bis 132 V	177 bis 264 V
Nominale Netz-Frequenz	50/60 Hz	50/60 Hz
Frequenzbereich	48,0 bis 62,0 Hz	48,0 bis 62,0 Hz
Phase	einphasig	einphasig
Leistungsbedarf*	0,145 - 0,150 kW	0,145 - 0,145 kW
Stromaufnahme*	2,4 - 2,2 A	1,4 - 1,2 A
Phasenwinkel *Cos phi	0,60 - 0,57	0,50 - 0,50
Anlaufstrom	siehe Abbildung B-1.	siehe Abbildung B-1.
* gemessen bei rotierendem Plattenstapel und Kopfschlitten in Bewegung.		

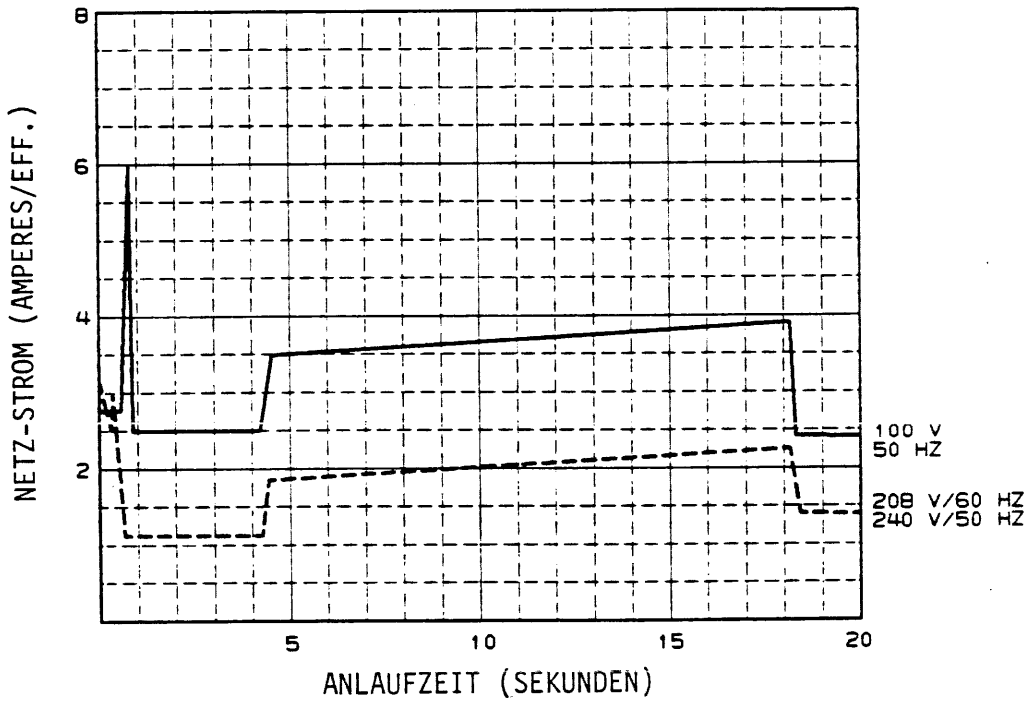
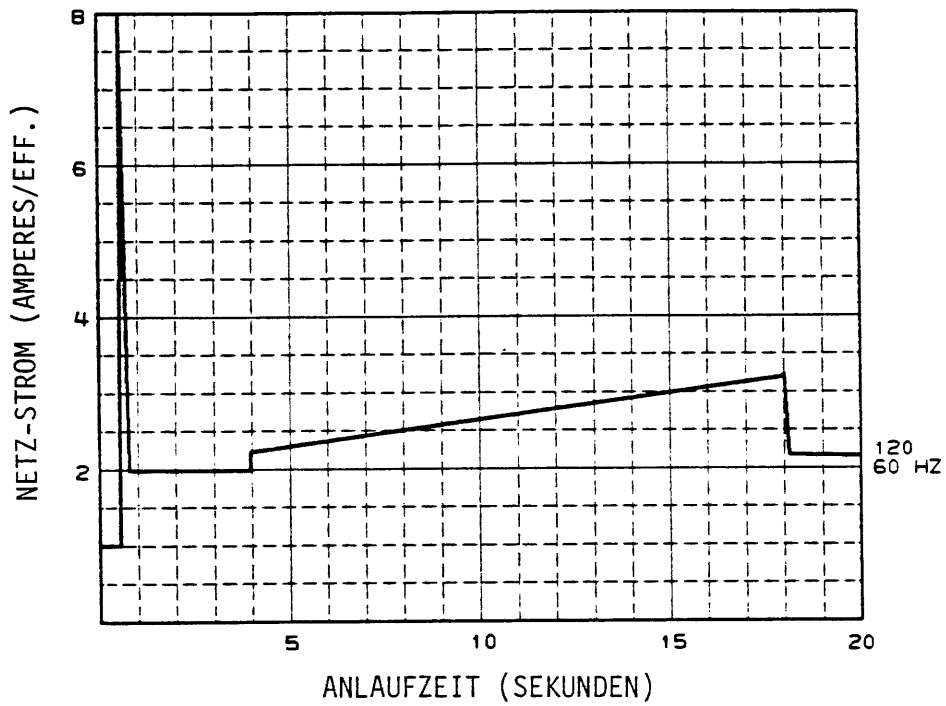

12J9

Abbildung B-1. Typischer Anlaufstrom im Verhältnis zur Zeit

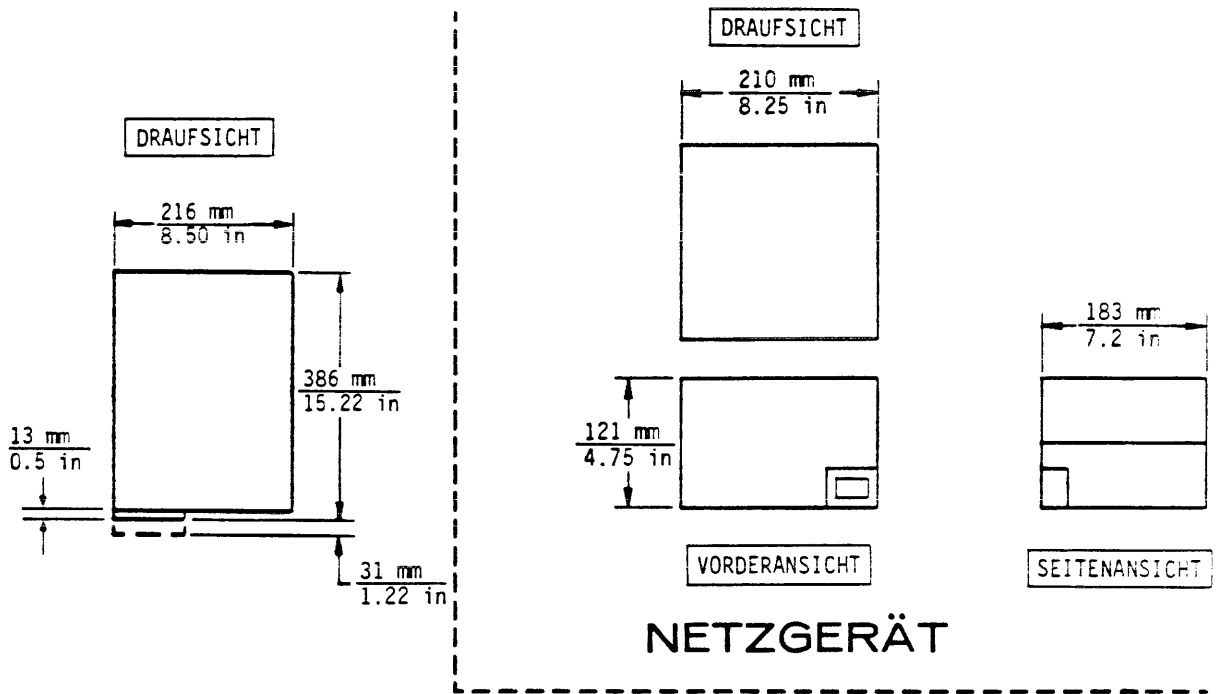

PLATTENLAUFWERK

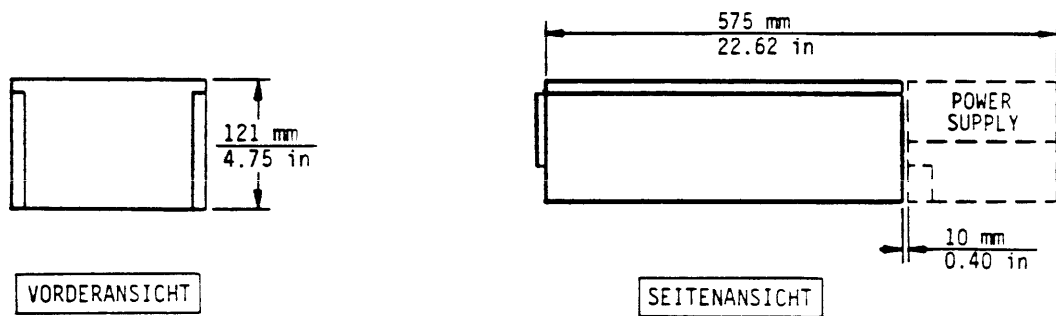

HINWEISE:

1. GEWICHT
 GERÄT ALLEINE = 13.0 kg (28.8 lb)
 NETZGERÄT ALLEINE = 3.6 kg (8 lb)
2. DIE ANGEgebenEN ABMESSUNGEN SIND
 NOMINAL-WERTE.

12J13A

Abbildung B-2. Abmessungen und Gewicht des Laufwerks

BETRIEBSANLEITUNG (mit Status/Control Panel oder Operator Panel)

EINSCHALTSEQUENZ

1. Den ON/STANDBY-Schalter am Netzgerät auf 1 (EIN) stellen.
2. Den START-Schalter drücken.
 - Wurde während des Installationsvorganges der POWER-ON-SEQUENCE-Schalter an der I/O-Karte auf 1 (geschlossen) gestellt, beginnt die Einschaltsequenz unmittelbar.
 - Wurde der POWER-ON-SEQUENCE-Schalter während des Installationsvorganges auf 0 (Offen) gestellt, beginnt die Sequenz verzögert. Die Verzögerung wirkt in Abstufungen von jeweils 5 sec, abhängig von der Laufwerksadresse (Adresse 0 startet sofort, Adresse 7 um 35 sec verzögert).
3. Nach Ablauf der Verzögerungszeit blinkt die Bereitschaftsanzeige (im START-Schalter integriert) in rascher Folge, was auf den Ablauf der Einschaltsequenz hinweist.
4. Die Bereitschaftsanzeige wechselt innerhalb von 90 sec auf Dauerlicht, nachdem das Laufwerk Nenndrehzahl erreicht hat und die Magnetköpfe eingefahren sind.
5. Die FAULT-Anzeige muß unbeleuchtet sein, was anzeigt, daß kein Fehler auftrat und das Gerät zum Lesen oder Schreiben von Daten bereit ist.

AUSSCHALTSEQUENZ

1. START-Schalter drücken.
2. Die Bereitschaftsanzeige (im START-Schalter integriert) blinkt langsam, was den Ablauf der Ausschaltsequenz anzeigt.
3. Die Bereitschaftsanzeige erlischt nach ca. 60 sec. Damit ist die Ausschaltsequenz abgeschlossen. Die Köpfe befinden sich jetzt in der Landezone und die Spindelrotation kommt zum Stillstand.
4. Zur Unterbrechung des Gleichspannungsanschlusses zum Netzgerät an letzterem den Schalter ON/STANDBY auf 0 (AUS) stellen.

BETRIEBSANLEITUNG (ohne Status/Control Panel oder Operator Panel)

EINSCHALTSEQUENZ

Am Netzgerät den Schalter ON/STANDBY auf 1 (EIN) stellen.

- Wurde der POWER-ON-SEQUENCE-Schalter (DIP SW3) während des Installationsvorganges auf 1 (geschlossen) gestellt, dann läuft die Einschaltsequenz unmittelbar an und ist nach innerhalb 90 sec beendet.
- Wurde der POWER-ON-SEQUENCE-Schalter (DIP SW3) während des Installationsvorganges auf 0 (OFFEN) gestellt, erfolgt die Einschaltsequenz verzögert. Die Verzögerungszeit ist in Abstufungen von jeweils 5 sec unterteilt, abhängig von der Laufwerksadresse (Adresse 0 startet unmittelbar, Adresse 7 ist um 35 sec verzögert). Die Einschaltsequenz ist in ca. 90 sec. nach deren Start abgeschlossen.

AUSSCHALTSEQUENZ

Zur Unterbrechung der Gleichspannungseinspeisung zum Laufwerk ist am Netzgerät der Schalter ON/STANDBY auf 0 (AUS) zu stellen.

APPENDICE C

INSTRUCTIONS D'INSTALLATION ET DE FONCTIONNEMENT

INSTRUCTIONS D'INSTALLATION ET DE FONCTIONNEMENT C

INTRODUCTION

Cet appendice contient les informations sécuritaires indispensables pour l'installation, le fonctionnement et la maintenance de l'appareil.

INFORMATION DE SECURITE

- Afin d'assurer l'intégralité des conditions sécuritaires installées dans l'appareil, l'installation et la maintenance doivent être accomplies exclusivement par un personnel qualifié utilisant des pièces recommandées Imprimis.
- En cas d'incendie ou autres états d'urgence, isolez l'appareil de la source de courant en retirant la fiche secteur de la prise de courant. Pour les situations où il n'est pas possible ou praticable de retirer la fiche, utilisez la déconnexion générale du système pour isoler les appareils de la source de courant.
- Si l'appareil est monté en rack ou en armoire, assurez-vous que la température interne du rack ou de l'armoire ne dépasse pas les limites définies pour l'appareil. Lorsque les appareils sont empilés verticalement, portez votre attention sur la partie supérieure du rack ou de l'armoire où les températures sont généralement plus élevées.
- Cet appareil est conçu pour être installé et de fonctionner en accordance avec IEC380, IEC435, VDE0805 et VDE0806.
- L'interrupteur de l'alimentation ne coupe pas la tension secteur. L'interrupteur placé sur On (1) permet la distribution des tensions continues, sur la position Standby (0) elles sont bloquées. Mais dans les deux cas la tension secteur est présente à l'intérieur de l'alimentation.
- Si l'alimentation est branchées à un réseau IT, faites le nécessaire afin que la tension d'entrée ne dépasse pas 230 volts.
- Abstenez vous de décortiquer l'alimentation. Elle n'est pas reparable sur place. Remplacez l'alimentation complète en cas de panne.

- Si vous n'utilisez pas une alimentation recommandée Imprimis, assurez vous que l'alimentation soit conforme aux spécifications de ce manuel et qu'elle soit conçue pour être utilisée en accordance avec IEC380, IEC435, VDE805 et VDE806.

CONDITIONS D'INSTALLATION

Le lieu d'installation doit être conforme aux spécifications données dans les tableaux et figures suivants.

TABLEAU C-1. CONDITIONS DE L'ENVIRONNEMENT

<u>TEMPERATURE</u>	<u>MARGE</u>	<u>FLUCTUATION MAXIMALE</u>
Stockage (Emballée)	-10 à 50°C	15°C par heure
Transport (Emballée)	-40 à 60°C	20°C par heure
En service	+10 à 45°C	15°C par heure
<u>HUMIDITE RELATIVE</u>		
Stockage (Emballée)	5% à 95% (pas de condensation autorisée)	
Transport (Emballée)	5% à 95% (pas de condensation autorisée)	
En service	20% à 80% (pas de condensation autorisée)	
<u>PRESSION BAROMETRIQUE</u>		
Stockage (Emballée)	-305 m à 3000 m ou 104 kPa à 69 kPa	
Transport (Emballée)	-305 m à 12 192 m ou 104 kPa à 19 kPa	
En service	-305 m à 3000 m ou 104 kPa à 69 kPa	

TABLEAU C-2. EXIGENCES POUR L'ALIMENTATION

SPECIFICATIONS	VALEURS	
	100 - 120 V ac	208 - 240 V ac
Marge de tension	85 à 132 V	177 à 264 V
Fréquence nominale du réseau	50/60 Hz	50/60 Hz
Marge de fréquence	48.0 à 62.0 Hz	48.0 à 62.0 Hz
Phase exigée	Monophasé	Monophasé
Puissance consommée*	0.145 - 0.150 kW	0.145 - 0.145 kW
Courant au réseau*	2.4 - 2.2 A	1.4 - 1.2 A
Cosinus Phi*	0.60 - 0.57	0.50 - 0.50
Courant de mise en route	Voir figure C-1.	Voir figure C-1.

* Mesuré lorsque les disques sont en rotation et que le chariot soit en mouvement.

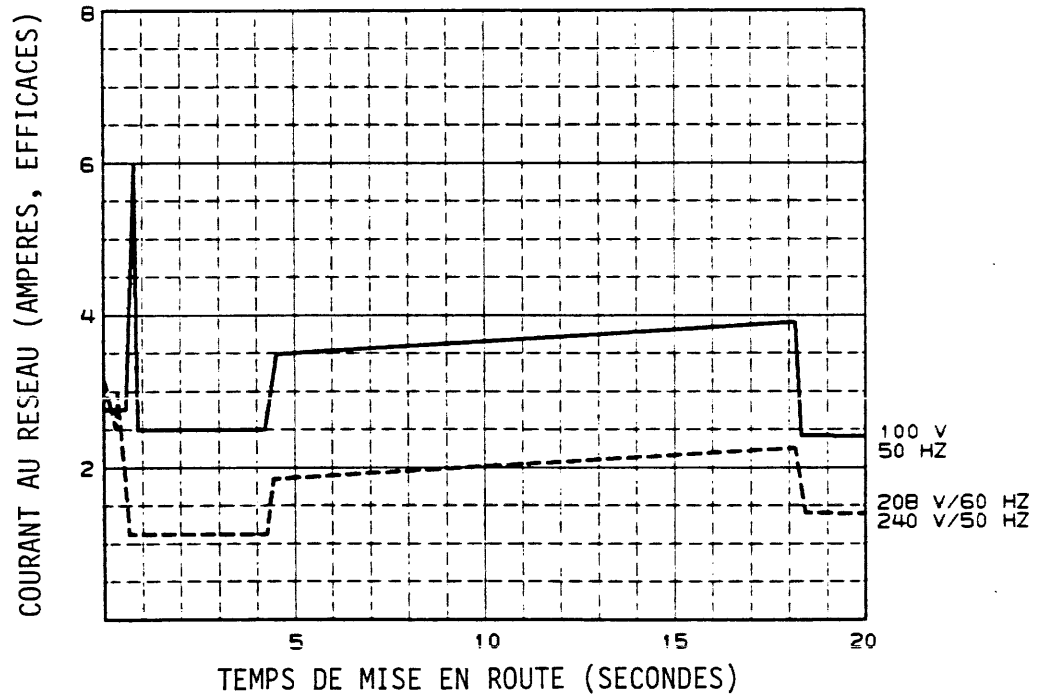
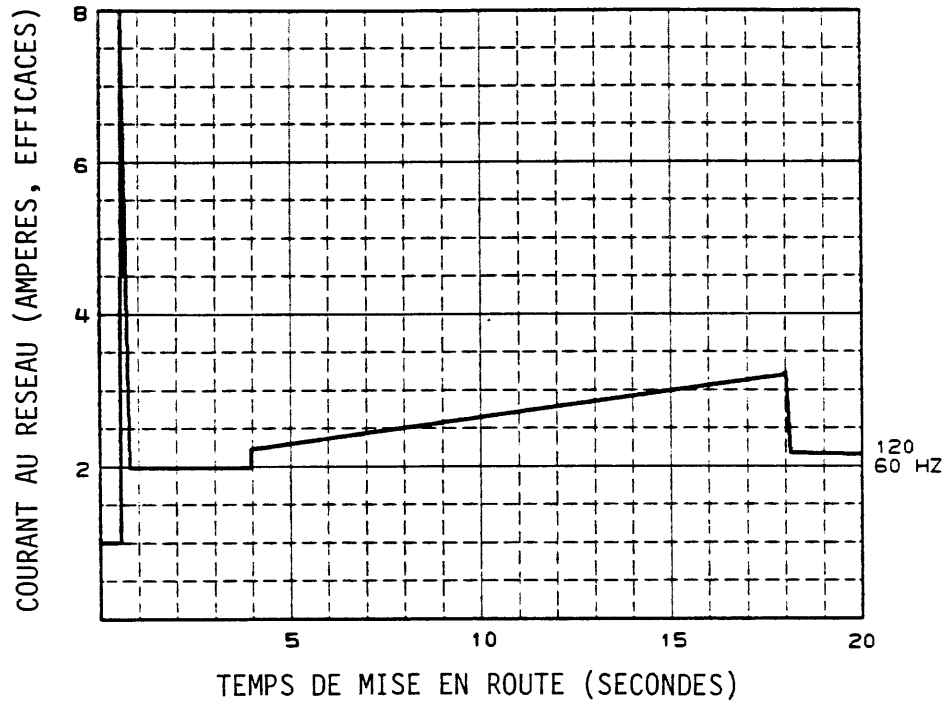

12J10

Figure C-1. Courant typique par rapport au temps de mise en route

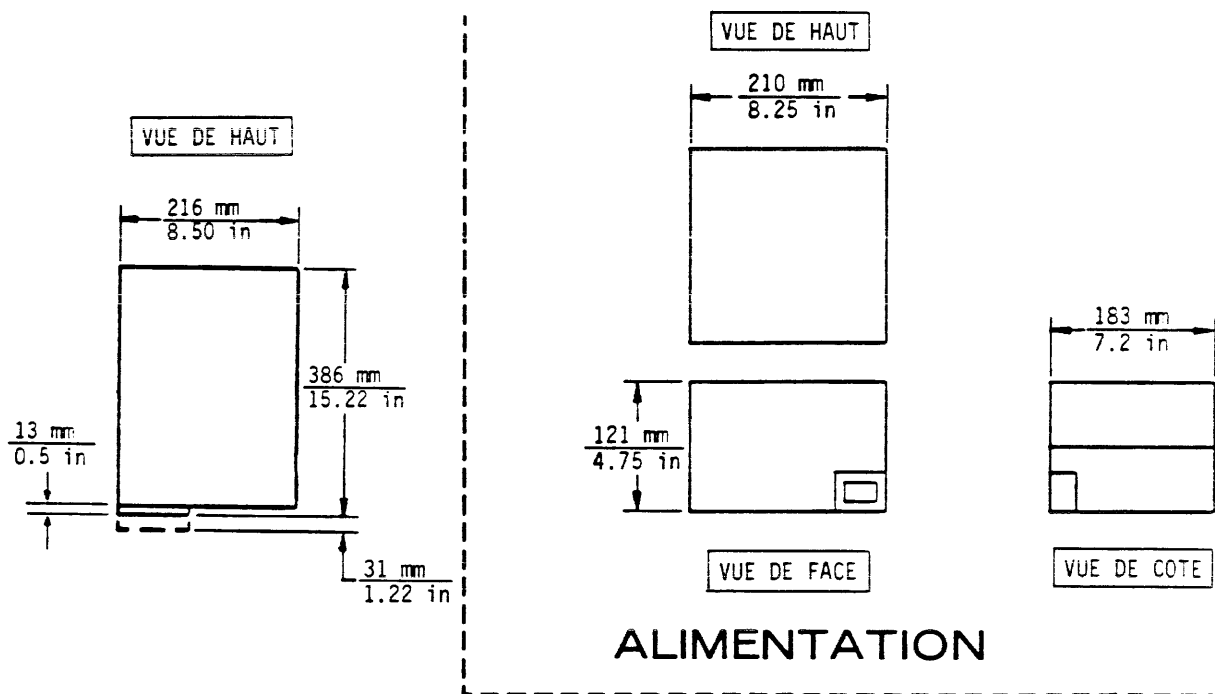

APPAREIL

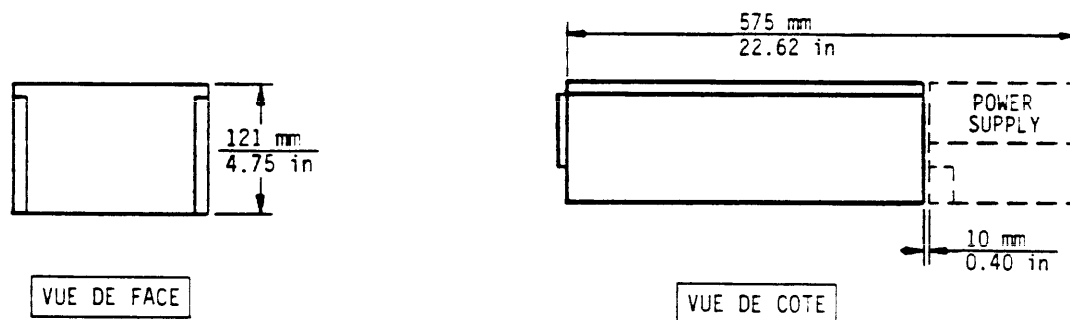

NOTES:

1. MASSE
 APPAREIL SEUL = 13.0 kg (28.8 lb)
 ALIMENTAIRE SEULE = 3.6 kg (8 lb)
2. LES DIMENSIONS DONNEES SONT NOMINALES.

12J14A

Figure C-2. Dimensions et poids des appareils

INSTRUCTIONS DE FONCTIONNEMENT (avec panneau status/control ou operator)

PROCEDURE DE MISE EN ROUTE

1. Placez l'interrupteur On/Standby de l'alimentation sur 1 (On).
2. Pressez l'interrupteur START.
 - Si le commutateur "Power On Sequence" sur la carte I/O à été placé sur 1 (fermé) à l'installation, la séquence de mise en route démarre aussitôt.
 - Si le commutateur "Power On Sequence" à été placé sur 0 (Open) à l'installation, la séquence est retardée. Le délai est incrémenté de 5 secondes dépendamment de l'adresse de l'appareil (l'adresse 0 démarre aussitôt, l'adresse 7 est retardée pour 35 secondes).
3. Lorsque le délai est écoulé, l'indicateur READY (placé dans l'interrupteur START) clignote rapidement pour signaler que la mise en route est en progression.
4. Observez que l'indicateur READY luise continuellement dans un délai de 90 secondes pour signaler que les disques ont atteints leur vitesse nominale et que les têtes sont chargées.
5. Observez que l'indicateur FAULT soit éteint pour signaler l'absence d'erreurs et que l'appareil est prêt à lire ou écrire des données.

PROCEDURE D'ARRET

1. Pressez l'interrupteur START.
2. Observez que l'indicateur READY (placé dans l'interrupteur START) clignote lentement pour signaler que la séquence d'arrêt est en progression.
3. Observez que l'indicateur READY s'éteigne après environ 60 secondes pour signaler que l'arrêt est complet. Les têtes sont maintenant positionnées dans la zone d'atterrissage et les disques ne sont pas en rotation.
4. Retirez la tension continue de l'appareil en plaçant l'interrupteur On/Standby de l'alimentation sur 0 (Off).

INSTRUCTIONS DE FONCTIONNEMENT (sans panneau status/control ou operator)

PROCEDURE DE MISE EN ROUTE

Placez l'interrupteur On/Standby de l'alimentation sur 1 (On).

- Si le commutateur "Power On Sequence" (DIP SW3) sur la carte I/O à été placé sur 1 (fermé) à l'installation, la séquence de mise en route démarre aussitôt et est complète après environ 90 secondes.
- Si le commutateur "Power On Sequence" (DIP SW3) à été placé sur 0 (Open) à l'installation, la séquence de mise en route est retardée. Le délai est incrémenté de 5 secondes dépendamment de l'adresse de l'appareil (l'adresse 0 démarre aussitôt, l'adresse 7 est retardée pour 35 secondes). Une fois démarrée, la séquence est complète après environ 90 secondes.

PROCEDURE D'ARRET

Retirez la tension continue de l'appareil en placent l'interrupteur On/Standby de l'alimentation sur 0 (Off).

APENDICE D

REQUISITOS DE INSTALACION Y OPERACION

INTRODUCCION

Este apéndice contiene información pertinente a la instalación, operación y mantenimiento seguro del disco.

INFORMACION DE SEGURIDAD

- Para asegurar la integridad de las características de seguridad integradas en el disco, la instalación y el mantenimiento deben ser realizadas solamente por personal de servicio cualificado utilizando solamente piezas originales de Imprimis.
- En caso de fuego u otra emergencia, aislar el disco de la fuente principal de energía, desenchufando el cable de corriente del disco de la salida de corriente alterna. En situaciones donde quitar el enchufe no es posible ni práctico, utilice el sistema de desconexión principal para aislar los discos de las fuentes de energía.
- Cuando el disco está montado en un estante de equipos o en un armario, asegúrese de que la temperatura interna del armario no sobrepase los límites definidos para el disco. Cuando las unidades están almacenadas verticalmente, preste particular atención a la parte superior donde las temperaturas son normalmente más altas.
- Este disco está diseñado para ser instalado y operado de acuerdo a las normas IEC380, IEC435, VDE805 y VDE806.
- El interruptor de la fuente de alimentación no controla la entrada de corriente alterna. Poniendo el interruptor a "On" (1) habilita las salidas de corriente continua, y poniendolo en "Standby" (0) las deshabilita. Pero en ambos casos la corriente alterna está presente dentro de la alimentación.
- Si la fuente de alimentación está conectada a un circuito IT, asegúrese que la tensión de entrada está limitada a 230 voltios.
- No intente desensamblar la fuente de alimentación. Ha de ser reparada en fábrica. Reemplace la fuente de alimentación en su totalidad en caso de ser defectuosa.

- Si no utiliza una fuente de alimentación recomendada por Imprimis asegúrese que la fuente de alimentación cumple las especificaciones de este manual y está diseñada para ser usada de acuerdo con las normas IEC380, IEC435, VDE805 y VDE806.

REQUISITOS DE INSTALACION

El local de la instalación debe cumplir las especificaciones dadas en las siguientes tablas y cifras.

TABLA D-1. REQUISITOS AMBIENTALES

<u>TEMPERATURA</u>	<u>RANGO</u>	<u>VARIACION MAXIMO</u>
Sin operar (desempaquetada)	-10 a 50 <u>o</u> C	15 <u>o</u> C por hora
Almacenada (embalada)	-40 a 60 <u>o</u> C	20 <u>o</u> C por hora
Operando	10 a 45 <u>o</u> C	15 <u>o</u> C por hora
<u>HUMEDAD RELATIVA</u>		
Sin operar (desempaquetada)	5% a 95% (sin condensación)	
Almacenada (embalada)	5% a 95% (sin condensación)	
Operando	20% a 80% (sin condensación)	
<u>PRESION BAROMETRICA</u>		
Sin operar (desempaquetada)	-305 m a 3000 m ó 104 kPa a 69 kPa	
Almacenada (embalada)	-305 m a 12 192 m ó 104 kPa a 19 kPa	
Operando	-305 m a 3000 m ó 104 kPa a 69 kPa	

TABLA D-2. REQUISITOS DE ENERGIA

ESPECIFICACIONES	VALORES	
	Unidad de 100/120	Unidad de 208/240
Margen de tensión	85 a 132 V	177 a 264 V
Frecuencia nominal	50/60 Hz	50/60 Hz
Margen de Frecuencia	48 a 62 Hz	48 a 62 Hz
Fases	Monofásico	Monofásico
Consumo de Potencia*	0,145 - 0,150 kW	0,145 - 0,145 kW
Consumo de corriente*	2,4 - 2,2 A	1,4 - 1,2 A
Factor de potencia	0,60 - 0,57	0,50 - 0,50
Corriente de arranque	Vea la figura D-1	Vea la figura D-1
* Medidas cuando los discos están girando y el actuador moviendose.		

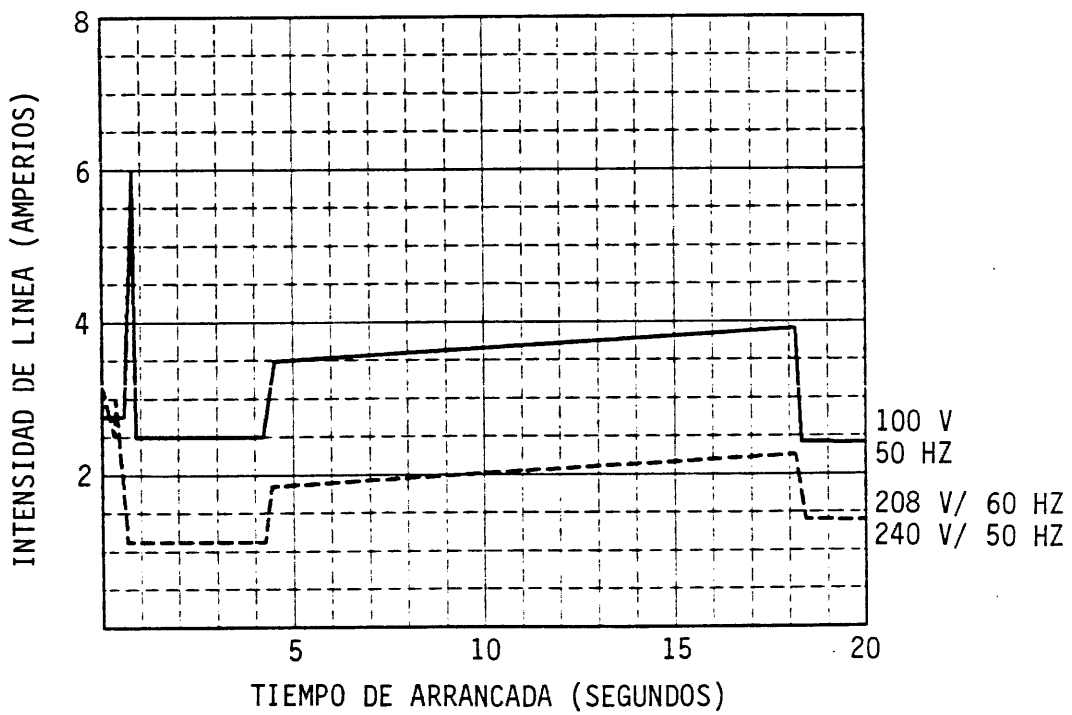
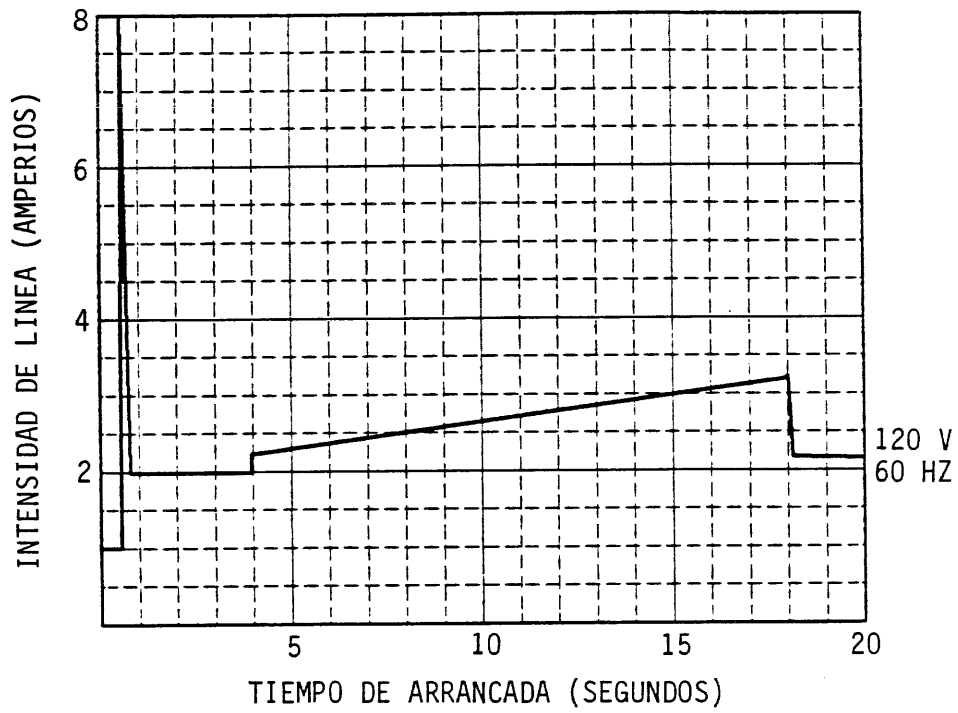

12J35

Figura D-1. Intensidad de línea y tiempos de arrancada

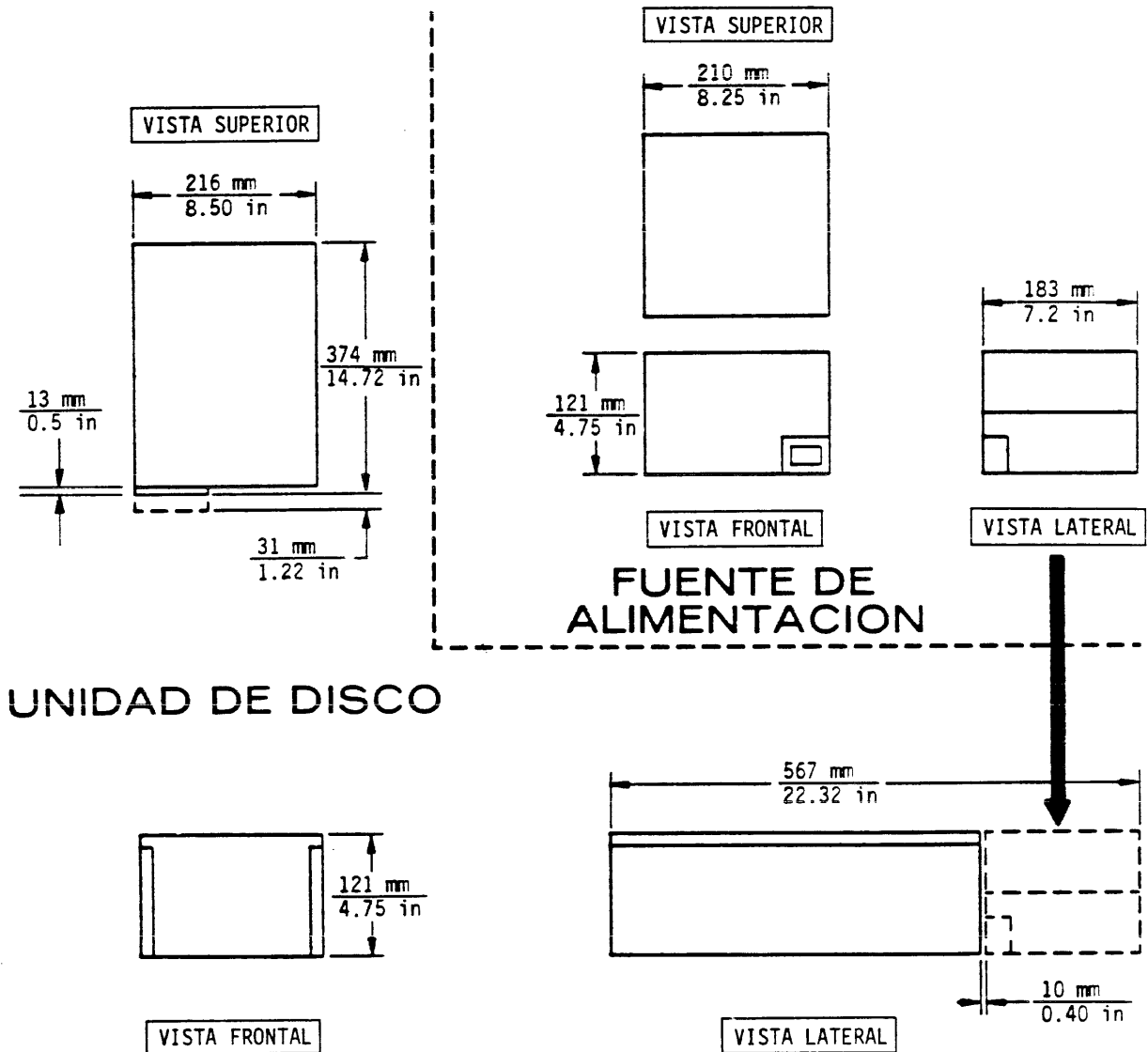

NOTAS:

1. MASA
 UNIDAD DE DISCO SOLAMENTE = 13,0 kg (28,8 LIBRAS)
 FUENTE DE ALIMENTACION SOLAMENTE = 3,6 kg (8 LIBRAS)
2. LAS DIMENSIONES SON NOMINALES.

12J37

Figura D-2. Dimensiones y peso de la unidad de disco

INSTRUCCIONES DE OPERACION (Con Panel Status/Control ó Operator)

PROCEDIMIENTO DE ENCENDIDO

1. Fije el interruptor "On/Standby" de la fuente de alimentación en la posición 1 (On).
2. Pulse el interruptor "START"
 - Si el interruptor de "Power on Sequence" en la tarjeta de I/O ha sido fijado en la posición 1 (cerrado) durante la instalación. La secuencia de encendido comienza inmediatamente.
 - Si el interruptor de "Power on Sequence" ha sido fijado en la posición 0 (abierto) durante la instalación, la secuencia se retrasa. El retardo es en incrementos de 5 segundos dependiendo de la dirección del dispositivo (la unidad 0 empieza inmediatamente, la unidad 7 se retrasa 35 segundos).
3. Cuando el retardo finaliza, el indicador "READY" (localizado en el interruptor de START) parpadea rápidamente indicando que la secuencia de encendido está en marcha.
4. Observe que el indicador de "READY" se enciende fijo dentro de 90 segundos indicando que los discos están a la velocidad adecuada y las cabezas están cargadas.
5. Observe que el indicador de "FAULT" permanece apagado indicando que no han ocurrido errores y el disco está disponible para leer ó escribir datos.

PROCEDIMIENTO DE APAGADO

1. Pulse el interruptor "START"
2. Observe que el indicador de "READY" (localizado en el interruptor de "START") parpadea lentamente indicando que la secuencia de apagado está en marcha.
3. Observe que el indicador de "READY" se apaga totalmente después de 60 segundos aproximadamente indicando que el apagado ha finalizado. Las cabezas están ahora posicionadas en la zona de aterrizaje y los discos no giran.
4. Retire la corriente continua de la unidad fijando el interruptor "On/Standby" de la fuente de alimentación a la posición 0 (Off).

INSTRUCCIONES DE OPERACION (Sin Panel Status/Control ó Operator)

PROCEDIMIENTO DE ENCENDIDO

Fije el interruptor "On/Standby" de la fuente de alimentación en la posición 1 (On).

- Si el interruptor "Power on Sequence" (DIP SW3) de la tarjeta de I/O fue fijado a 1 (cerrado) durante la instalación, la secuencia de encendido comienza inmediatamente y finaliza en 90 segundos aproximadamente.
- Si el interruptor "Power on Sequence" (DIP SW3) fue fijado a 0 (abierto) durante la instalación, la secuencia de encendido se retarda. El aplazamiento es en incrementos de 5 segundos dependiendo de la dirección de la unidad (la unidad 0 comienza inmediatamente, la unidad 7 se retrasa 35 segundos). Una vez comenzada, la secuencia finaliza en aproximadamente 90 segundos.

PROCEDIMIENTO DE APAGADO

Retire la energía de la unidad fijando el interruptor "On/Standby" de la fuente de alimentación en la posición 0 (Off).

COMMENT SHEET

Manual Title: _____

Publication No: _____

Revision: _____

Name: _____

Company: _____

Street Address: _____

City: _____ **State:** _____ **Zip Code:** _____

This form is not intended to be used as an order blank. Seagate welcomes your evaluation of this manual. Please indicate any errors, suggested additions or deletions, or general comments below (please include page number references)

Please reply

No reply necessary

Cut along line

Printed in U.S.A.

KØR 050ZF

No postage stamp necessary if mailed in U.S.A.

Fold on dotted lines and tape. Postal regulations prohibit the use of staples.

FOLD

FOLD

FIRST CLASS
PERMIT NO. 8241

MINNEAPOLIS, MINN.

BUSINESS REPLY MAIL

NO POSTAGE STAMP NECESSARY IF MAILED IN U. S. A.

POSTAGE WILL BE PAID BY

SEAGATE TECHNOLOGY, INC.
TECHNICAL PUBLICATIONS DEPARTMENT
12701 WHITEWATER DRIVE
MINNETONKA, MN. 55343



CUT ALONG LINE

FOLD

FOLD

 **Seagate**
Seagate Technology, Inc.
920 Disc Drive, Scotts Valley, California 95066-4544, USA
