

PRODUCT SPECIFICATION  
FOR  
LARK MODULE DRIVE  
MODEL 9455

PRODUCT SPECIFICATION  
FOR  
LARK MODULE DRIVE  
MODEL 9455

		PC	SPEC. NO.	SHEET	REV
		A	77641922	2	A

PRODUCT SPECIFICATION - 9455 LMD

TABLE OF CONTENTS

1.0	SCOPE .....	4
2.0	APPLICABLE DOCUMENTS .....	4
2.1	DRAWINGS AND SPECIFICATIONS .....	4
2.2	STANDARDS .....	4
2.3	DOCUMENTATION .....	4
3.0	GENERAL DESCRIPTION .....	5
3.1	EQUIPMENT DEFINITION .....	5
3.1.1	Performance Summary .....	6
3.1.2	Rack Mounting .....	6
3.1.3	Power and Input/Output Module (PIO) .....	12
3.1.4	Peripheral Interface Adapter .....	12
3.1.5	Configurations .....	12
3.1.6	Options .....	12
3.1.7	Accessories .....	12
3.1.8	Voltage Conversions .....	12
4.0	PERFORMANCE .....	14
4.1	ACCESS TO DATA CHARACTERISTICS .....	14
4.1.1	Positioning Times .....	14
4.1.2	Spindle Speed & Latency .....	14
4.1.3	Read Initialization Time .....	14
4.1.4	Write to Read Recovery Time .....	15
4.1.5	Read to Write Recovery Time .....	15
4.2	DATA CAPACITY .....	15
4.3	DATA TRANSFER RATE .....	15
4.4	ERROR RATES .....	15
4.4.1	Read Errors .....	15
4.4.2	Environmental Errors .....	16
4.4.3	Write Errors .....	16
4.4.4	Seek Errors .....	16
4.5	DATA SECURITY .....	16
4.6	START/STOP TIME .....	17
5.0	MEDIA CHARACTERISTICS .....	17
5.1	GENERAL .....	17
5.2	CARTRIDGE DESCRIPTION .....	18
5.3	FIXED MEDIA DESCRIPTION .....	18
5.4	FIELD REPLACEMENT OF FIXED MEDIA .....	18
5.5	ALLOWABLE MEDIA DEFECTS .....	18
5.5.1	LMD Fixed Media .....	19
5.5.2	LMD Cartridge Media .....	19

		PC	SPEC. NO.	SHEET	REV
		A	77641922	3	A

PRODUCT SPECIFICATION - 9455 LMD

TABLE OF CONTENTS (continued)

6.0	ERROR RECOVERY CONSIDERATIONS .....	19
6.1	EARLY/LATE DATA STROBE .....	19
6.2	ALTERNATE TRACK ASSIGNMENTS .....	22
6.3	CRC/ECC IMPLEMENTATION .....	22
7.0	RECORDING CHARACTERISTICS .....	22
7.1	RECORDING MODE .....	22
7.2	DISKS .....	23
7.3	HEADS .....	23
8.0	CONTROLS AND INDICATORS .....	24
8.1	OPERATOR CONTROL PANEL .....	24
9.0	PHYSICAL CHARACTERISTICS .....	24
9.1	MICRO-MODULE DRIVE ( $\mu$ MD) .....	24
9.2	POWER AND INPUT/OUTPUT MODULE (PIO) .....	24
10.0	RELIABILITY AND SERVICE GOALS .....	26
10.1	MEAN TIME BETWEEN FAILURE .....	26
10.2	PREVENTIVE MAINTENANCE .....	26
10.3	SERVICE LIFE .....	26
11.0	INSTALLATION AND MAINTENANCE .....	28
11.1	POWER REQUIREMENTS .....	28
11.1.1	Primary Requirements .....	28
11.2	GROUNDING .....	29
11.3	ENVIRONMENTAL LIMITS .....	29
11.3.1	Temperature .....	29
11.3.2	Relative Humidity .....	29
11.3.3	Altitude .....	30
11.3.4	Vibration and Shock .....	30
11.3.5	Air Cleanliness .....	30

		PC	SPEC. NO.	SHEET	REV
		A	77641922	4	B

PRODUCT SPECIFICATION - 9455 LMD

1.0 SCOPE

This specification describes the Magnetic Peripherals Inc. 9455 Lark Module Drive (LMD), a member of CDC Module Drive family. The basic configurations are listed below:

PRODUCT NUMBER	VOLT/FREQ	CABINETRY	NUMBER OF SECTORS
9455-32	120/60	Rack	32
9455-64	120/60	Rack	64
9455-32A	220/230/240/50	Rack	32
9455-64A	220/230/240/50	Rack	64

2.0 APPLICABLE DOCUMENTS

2.1 DRAWINGS AND SPECIFICATIONS

75897451 Interface Specification for LMD  
76192089 CDC Disk Cartridge

2.2 STANDARDS

The 9455 LMD shall comply with Control Data Corporation standards as noted in the appropriate sections of this specification.

In addition to the corporate standards the LMD shall comply with the requirements of:

UL 478

CSA Standard C22.2 No. 154-1975

2.3 DOCUMENTATION

The following documentation will be available for field support of the Lark Module Drive at the time of the first production shipments.

77630473 Operation and Installation Instructions  
77647815 Lark Depot Level Maintenance Manual  
Later Voltage Conversion Instructions

		PC	SPEC. NO.	SHEET	REV
		A	77641922	5	A

## PRODUCT SPECIFICATION - 9455 LMD

### 3.0 GENERAL DESCRIPTION

#### 3.1 EQUIPMENT DEFINITION

The Lark Module Drive (LMD) is a small, low cost, medium performance, random access, rotating disk mass memory device featuring both removable and fixed storage. The LMD employs the latest 8 inch rigid disk technology using low mass flying read/write heads attached to a precisely controlled linear head positioner. The unformatted storage capacity of the LMD is 16.7 Mbytes. 8.35 Mbytes of storage is provided by the removable disk (cartridge) and 8.35 Mbytes of storage is provided by the non-removable disk excluding spare tracks. See Figure 1.

For Operator convenience, the removable cartridge is removed and inserted via a hinged access door on the front panel that locks when the disks are spinning. Operator controls and indicators consist of a START/STOP switch and a WRITE PROTECT switch for fixed disk. See Figure 2.

The LMD consists of two major assemblies as illustrated in Figure 1. One assembly is referred to as the Micro Module Drive ( $\mu$ MD) while the second of these assemblies is called the Power and Input/Output (PIO) Module. This configuration will provide a high degree of packaging flexibility to the user.

Basic components in the  $\mu$ MD consist of: Base casting, spindle, spindle drive motor, cartridge insertion and positioning mechanism, linear servo motor and carriage assembly with read/write heads, Base PWA with micro-computer control, Read Signal Processor PWA, and Read/Write Pre-amp PWA. A cooling blower is also provided.

The separate PIO module consists of a DC Power Source for the  $\mu$ MD and an interface adapter PWA for connection to the host system. See Figure 1.

A summary of several key features of the LMD follows:

- No Head Alignment Required
- Removable Cartridge
- Low Power Consumption
- Low Acoustic Noise
- SMD Interface Compatability
- Small Physical Size
- Embedded Servo
- LSI & Microcomputer Control

		PC	SPEC. NO.	SHEET	REV
		A	77641922	6	A

PRODUCT SPECIFICATION - 9455 LMD

3.1.1 Performance Summary

The performance characteristics of the 9455 LMD are shown in Table 1.

Table 1. Performance Characteristics

TOTAL CAPACITY (UNFORMATTED)*	9455
Removable Cart	8.35 MB
Fixed Disk	8.35 MB
Total	16.7 MB
*Based on 202 cylinders. Does not include 4 spares per surface.	
Number Cylinders (Total)	206
Number Data Heads	
Removable	2
Fixed	2
Total	4
Unformatted Track Capacity	20672 Bytes
Recording Mode	(2,9)
FRI	6774
TPI	237
Spindle Speed	3510 $\pm$ $\frac{2.5\%}{4.8}$ r/min
Data Transfer Rate (Nominal)	9.677 MHz
Maximum Latency	17.95 ms
Average Latency	8.55 ms

3.1.2 Rack Mounting

The  $\mu$ MD will accommodate installation in a standard RETMA rack or equivalent enclosure. Two  $\mu$ MD units, configured horizontally, will fit within a standard 5.25 in. opening; while three units configured vertically (spindle motor up) will fit within a standard 10.5 in. opening. See Figure 4. No slides are provided with the  $\mu$ MD but mounting holes are provided on the side of the base casting for vertical mounting and at the bottom of base casting for horizontal mounting as depicted in Figure 5.

		PC	SPEC. NO.	SHEET	REV
		A	77641922	7	A

PRODUCT SPECIFICATION - 9455 LMD

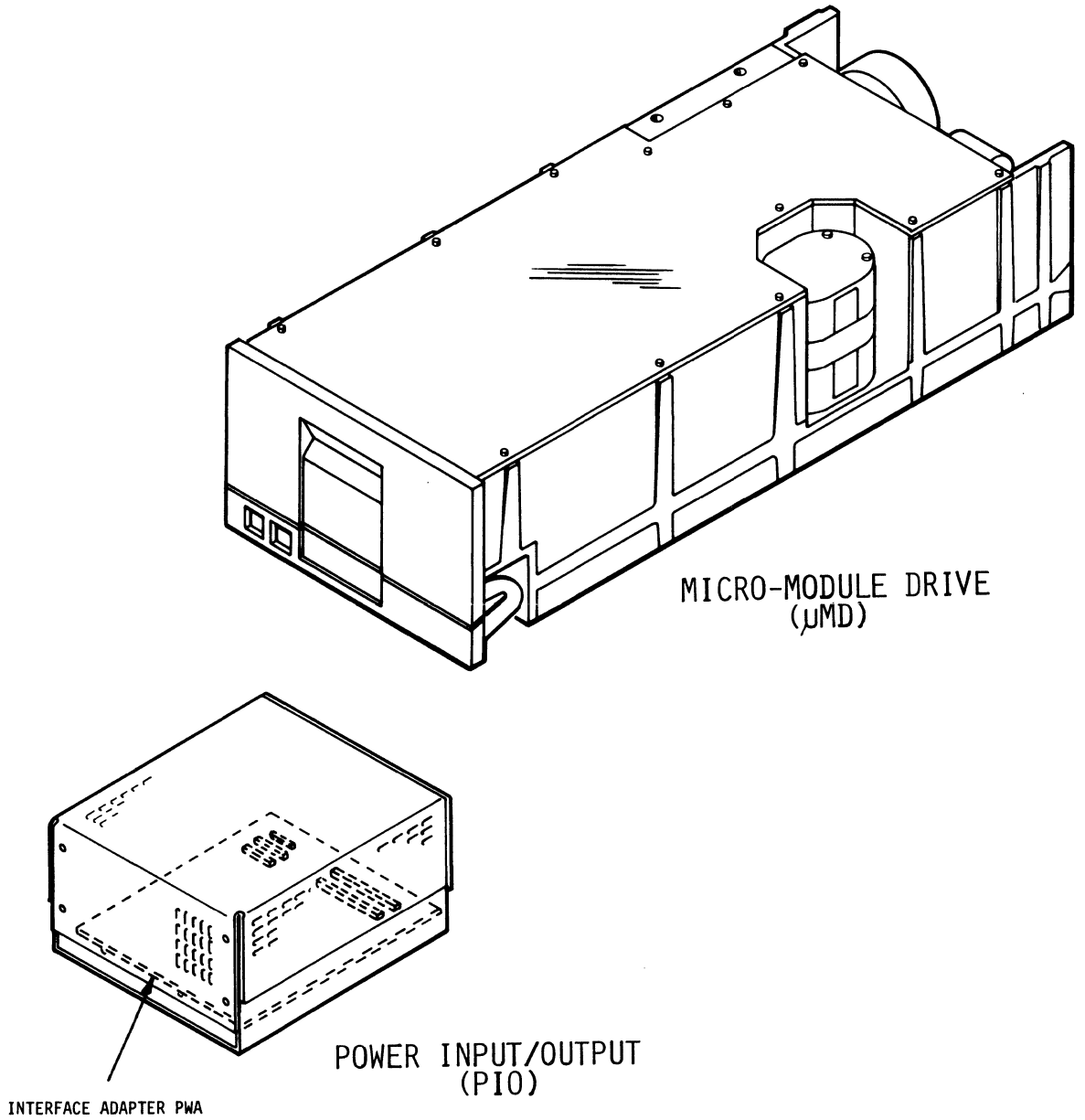

ZZ167b

Figure 1. Lark Module Drive (LMD)



		PC	SPEC. NO.	SHEET	REV
		A	77641922	8	A

PRODUCT SPECIFICATION - 9455 LMD

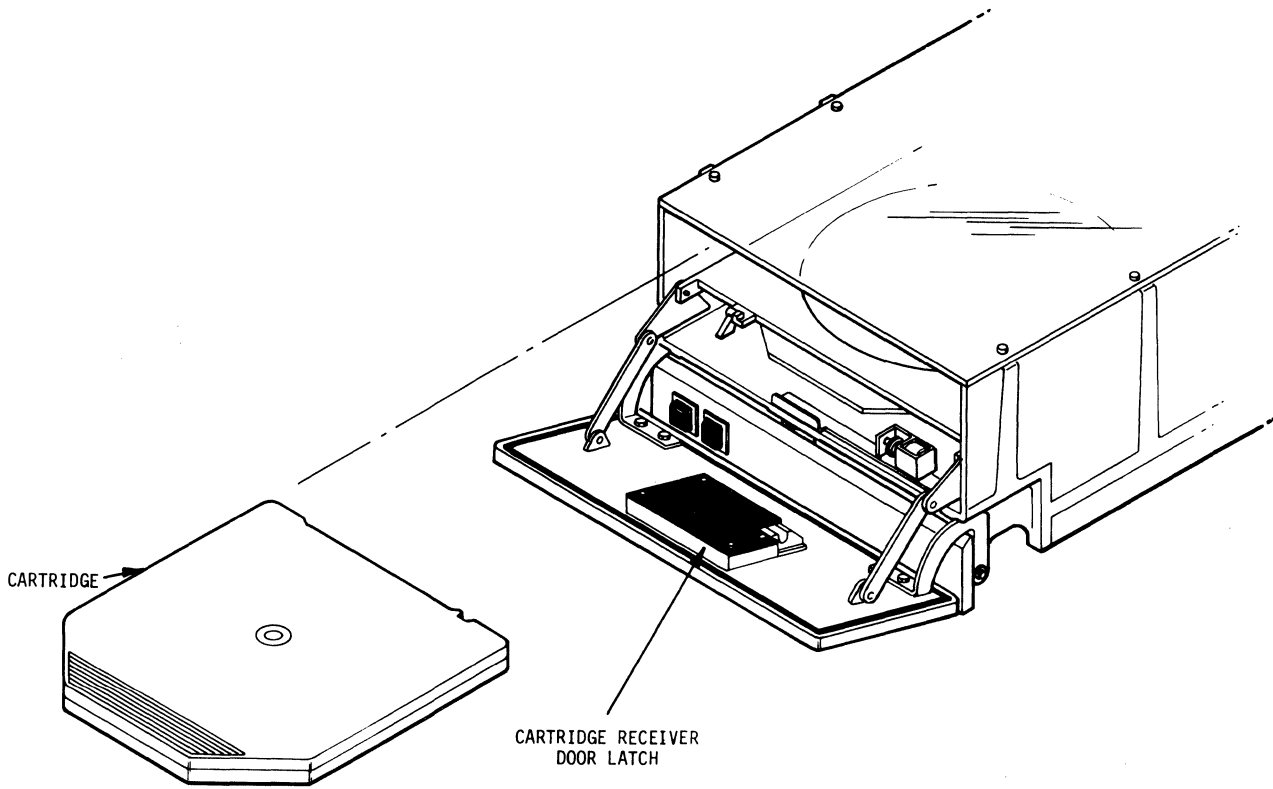

ZZ168a

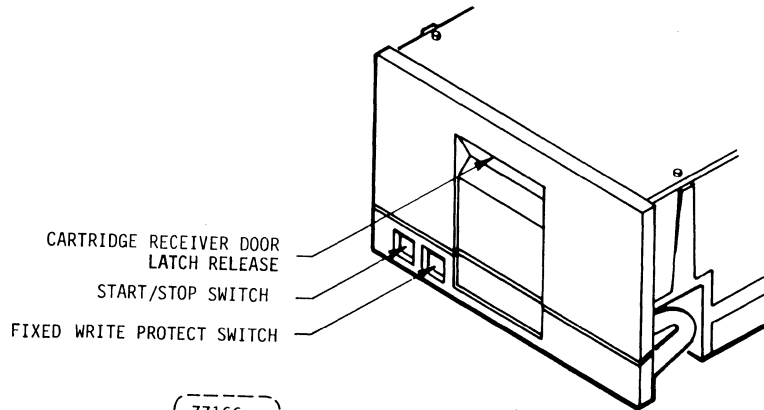

ZZ166c

Figure 2.  $\mu$ MD Front Panel

		PC	SPEC. NO.	SHEET	REV
		A	77641922	9	A

PRODUCT SPECIFICATION - 9455 LMD

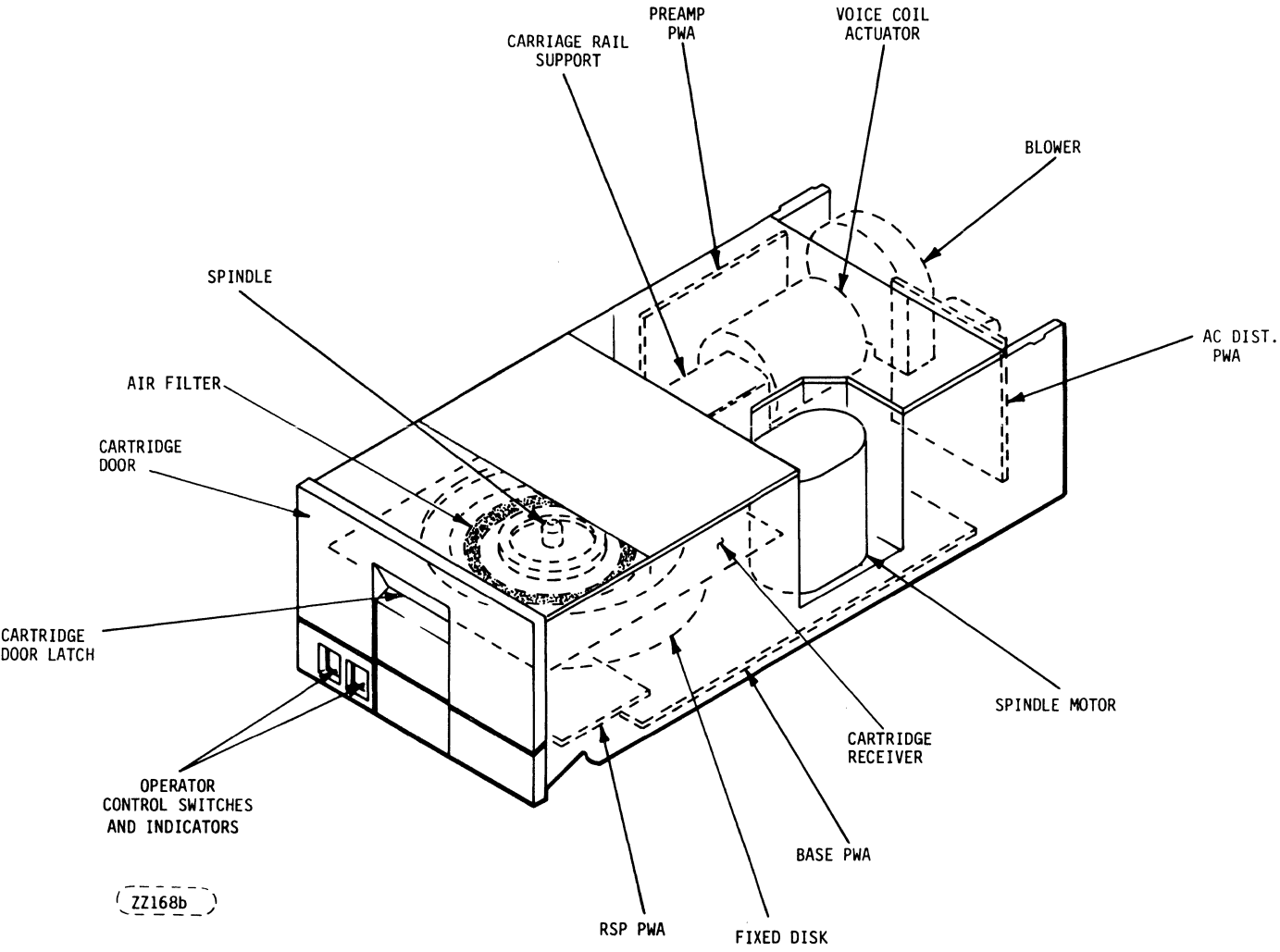

Figure 3. μMD Basic Components

		PC	SPEC. NO.	SHEET	REV
		A	77641922	10	A

PRODUCT SPECIFICATION - 9455 LMD

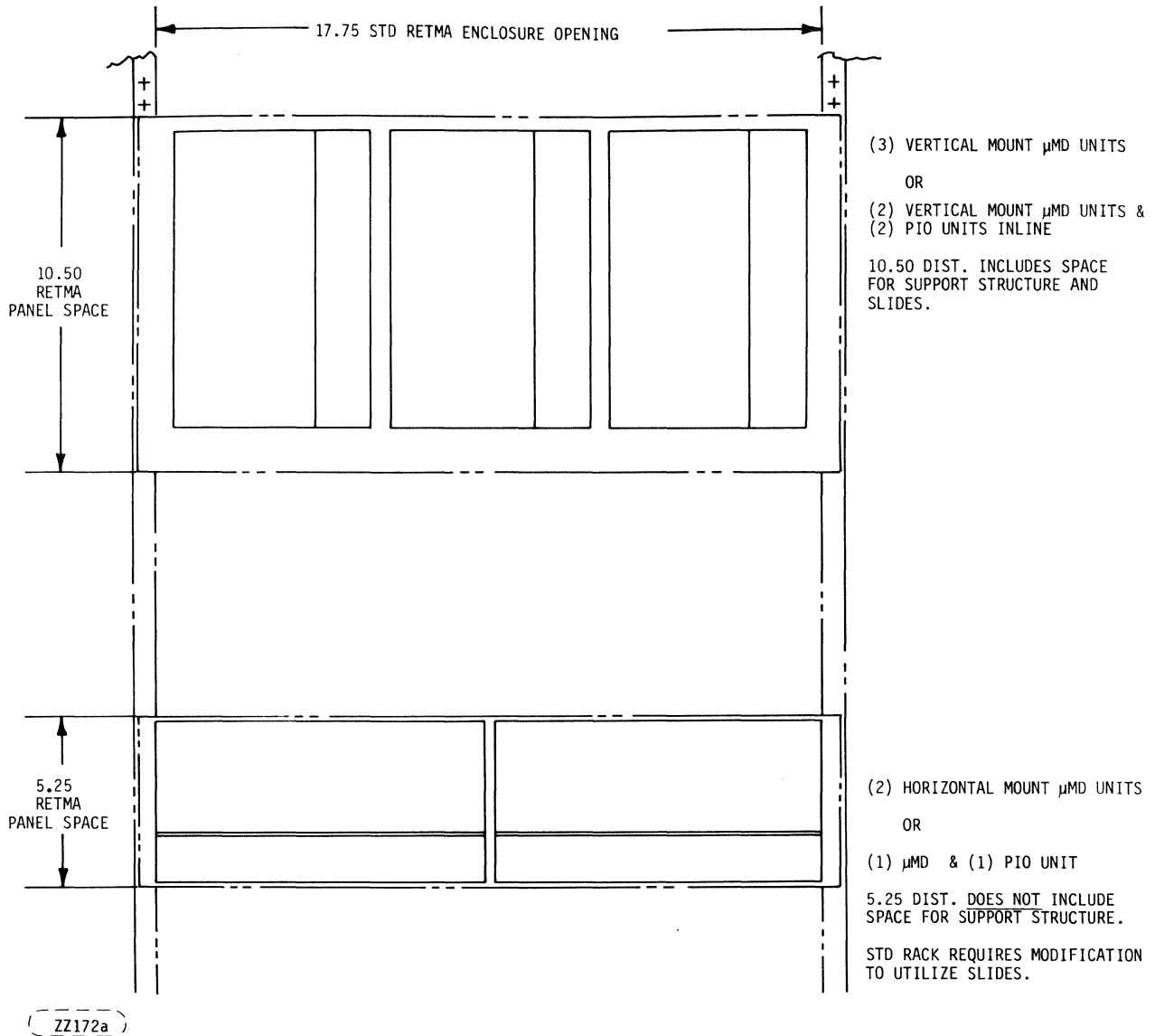
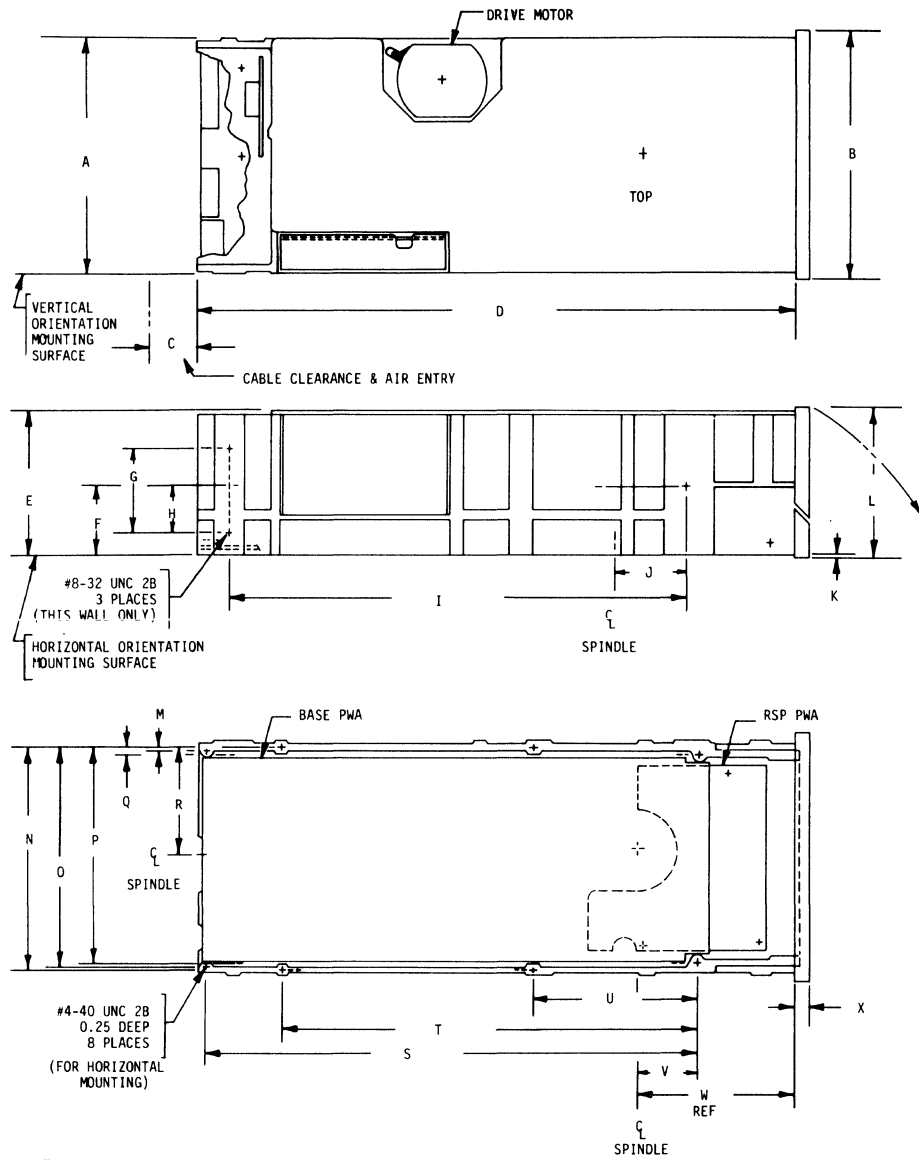

Figure 4. Typical Rack Mount Configurations

		PC	SPEC. NO.	SHEET	REV
		A	77641922	11	A

PRODUCT SPECIFICATION - 9455 LMD



DIMENSION	INCHES	MILLIMETERS	REMARKS
A	8.59	218.19	MAX
B	8.80	223.52	MAX
C	2.00	50.80	
D	21.00	533.40	
E	5.03	127.76	MAX
F	1.875	47.63	
G	3.00	76.20	
H	0.75	19.05	
I	16.37	415.80	
J	1.97	50.04	
K	0.09	2.29	
L	5.23	132.84	MAX

DIMENSION	INCHES	MILLIMETERS	REMARKS
M	0.145	3.68	MAX
N	8.280	210.31	
O	8.145	206.88	
P	8.015	203.58	
Q	0.265	6.73	
R	4.140	105.16	
S	17.550	445.77	
T	14.775	375.29	
U	5.950	151.13	
V	2.20	55.88	
W	5.14	130.56	REF
X	0.56	14.22	

ZZ206a

Figure 5. μMD Mounting Hole Data

		PC	SPEC. NO.	SHEET	REV
		A	77641922	12	A

PRODUCT SPECIFICATION - 9455 LMD

3.1.3 Power and Input/Output Module (PIO)

The PIO supplies the DC voltages required to operate the  $\mu$ MD. The supply voltages are: +5 V, -5 V, +16.5 V, and -16.5 V. Provisions are incorporated within the module for the peripheral interface adapter PWA. Mounting criteria is similar to the  $\mu$ MD unit. See Figure 5 for dimensional information.

3.1.4 Peripheral Interface Adapter

This PWA is contained within the PIO and is used to convert the  $\mu$ MD interface to storage module (SMD) interface for connection to the host system. Reference Figure 1.

3.1.5 Configurations

Two fixed sector configurations are available for the LMD, either a 64 sector or 32 sector version. The specific sector configuration desired must be ordered from the factory by model number 9455-64 for 64 sectors or model number 9455-32 for 32 sectors. A soft sector configuration is not available for the LMD.

A star or daisy chain connection may be used with the LMD up to a maximum of 4 drives.

3.1.6 Options

Seek on head change

3.1.7 Accessories

The following accessories may be purchased as required:

32 sector Data Cartridge	
64 sector Data Cartridge	
Terminator	75886100

3.1.8 Voltage Conversions

Two standard as-shipped voltage configurations are available for the LMD, either 120 VAC 60 Hz or 220 VAC 50 Hz. Field conversion of 50 Hz LMDs is possible by referring to voltage conversion instructions drawing number TBD.

		PC	SPEC. NO.	SHEET	REV
		A	77641922	13	A

PRODUCT SPECIFICATION - 9455 LMD

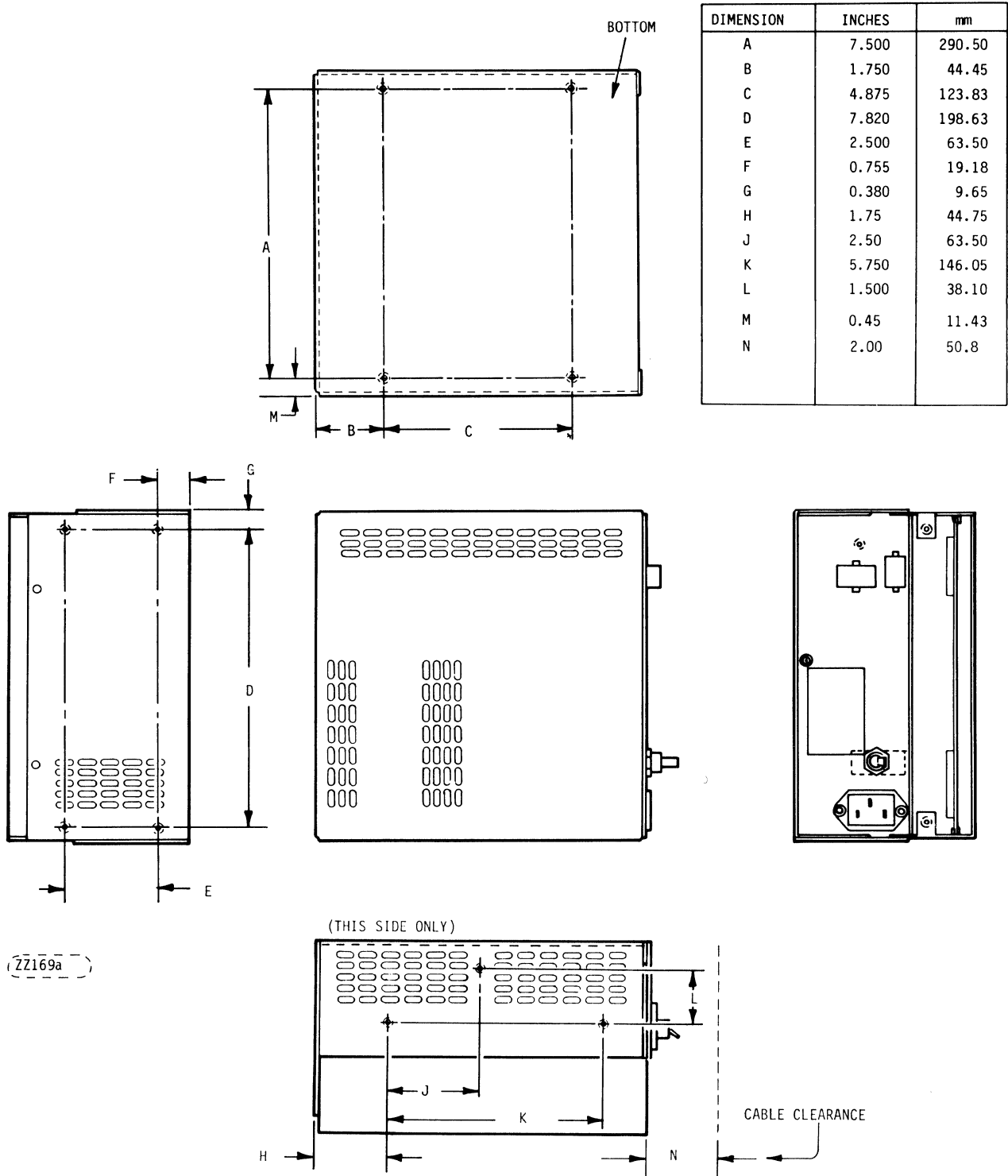

Figure 6. PIO Mounting Hole Data

		PC	SPEC. NO.	SHEET	REV
		A	77641922	14	B

PRODUCT SPECIFICATION - 9455 LMD

4.0 PERFORMANCE

4.1 ACCESS TO DATA CHARACTERISTICS

4.1.1 Positioning Times

This is defined as the time required from the receipt of a seek or position command by the LMD until the drive signals the controller it is ready to perform another seek or read/write function on the new cylinder. Issuance of a seek to the current cylinder position and head will cause On Cylinder to the controller to drop for a nominal period, though there is no carriage movement.

Positioning Times

Maximum	100 ms
Average	50 ms
Single Track (Adjacent)	10 ms
RTZ	500 ms max.

Average seek time is determined by dividing the sum of all possible movements by the total number of movements.

4.1.2 Spindle Speed & Latency

The spindle speed is 3510 +2.5-4.8% revolutions per minute (r/min). The speed tolerance includes motor performance, belt and pulley tolerances and the mains voltage and frequency variation specified in section 11.1. This does not include other variables which affect data transfer rates. Refer to Interface Spec. 75897451.

The average latency time is 8.55 ms, based on a nominal disk speed of 3510 r/min. The maximum latency time is 17.95 ms based on a minimum disk speed of 3342 r/min (3510 -4.8%).

Latency time is defined as the time required to reach a particular sector after positioning is complete.

4.1.3 Read Initialization Time

As a direct consequence of the embedded servo technique a head change command is essentially a zero track seek to another data surface, since the head that is used to read or write is also used to read pre-recorded servo track information contained in the data format tolerance gaps. Therefore this time is synonymous to a zero track seek with head change requiring TBD ms maximum to position to the newly selected surface at which time the read chain is stabilized to read data.

		PC	SPEC. NO.	SHEET	REV
		A	77641922	15	A

## PRODUCT SPECIFICATION - 9455 LMD

### 4.1.4 Write to Read Recovery Time

Assuming a write operation is in progress the required time interval between the end of write gate and the initiation of read gate is 10 micro-seconds minimum.

### 4.1.5 Read to Write Recovery Time

Assuming a read operation is in progress, the required minimum time interval between the end of read gate and the initiation of write gate is 0.3 micro-seconds.

## 4.2 DATA CAPACITY

The total unformatted data capacity of the LMD is 16,702,976 Bytes/Spindle. The total formatted data capacity using the recommended format is 13,238,272 Bytes/Spindle. This capacity does not include 4 spare tracks per surface.

## 4.3 DATA TRANSFER RATE

The nominal serial data transfer rate is 9,676,800 bits/sec. (1.2096 Mbytes/Second). The range of transfer rate variations on a byte/second basis for read/write operations is +4 -5.5% of the nominal. This range includes the effects of all factors including spindle speed variations and dynamic jitter on a byte to byte basis. Data on the interface is NRZ while the LMD internally converts this information to a 2,9 code for reading and writing.

## 4.4 ERROR RATES

The error rates stated in this specification assume:

- a. That the LMD is operated per specification.
- b. That a CDC approved data cartridge is employed.
- c. That a data format is employed fulfilling the requirements of the LMD as outlined in Interface Specification 75897451.
- d. That errors caused by media defects or LMD equipment failures are excluded.

### 4.4.1 Read Errors

Prior to the determination or measurement of read error rates:

- a. The data which is to be used for a measurement of read error rates must be verified as being written correctly on the media.
- b. All media defect induced errors must be excluded from error rate calculations.

A recoverable read error is one that can be re-read correctly in nine or less retries. These retries must include three retries at normal data strobe, three retries early data strobe, and three retries at late data strobe.



		PC	SPEC. NO.	SHEET	REV
		A	77641922	16	A

## PRODUCT SPECIFICATION - 9455 LMD

### 4.4.1 -contd.

The recoverable read error rate for any read operation shall be less than one error in  $10^{10}$  bits read.

An unrecoverable read error is one which cannot be read correctly after nine retries to read the record. These retries must include three retries at normal data strobe, three retries at early data strobe, and three retries at late data strobe.

The unrecoverable read error rate shall be less than one bit in  $10^{12}$  bits read.

### 4.4.2 Environmental Errors

When operating at low effective data transfer rate, e.g., random access of single short records, the effective error rate may be expected to exceed the above limits due to environmental interference. The resulting recoverable read error rate shall be no more than one error in eight hours of operation.

### 4.4.3 Write Errors

Write errors can occur as a result of the following: write data not being presented correctly, media defects, or equipment malfunction. As such, write errors are not predictable as a function of the number of bits passed.

For the case of an unrecoverable write error occurring because of a LMD equipment malfunction, the error is classified as a failure affecting MTBF. Unrecoverable write errors are those which cannot be corrected within three attempts at writing the record with a write verify after each attempt.

### 4.4.4 Seek Errors

A seek error is defined as a condition where the LMD fails to position to the correct track as indicated by the information on the I/O. There shall be no more than one recoverable seek error of this type in  $10^6$  physical seek operations. Non recoverable seek errors are classified as failures for MTBF calculations.

## 4.5 DATA SECURITY

Under normal controller I/O operation it is not possible to write a pattern other than that on the write data lines. It is possible to alter the bit pattern only when the LMD signifies an On Cylinder status, is not write protected via hardware or operator control, write gate is active, and then only upon specific selection of LMD. Data is protected by inhibiting write gate in the following FAULT conditions:

#### 1. Write Gate AND Servo Write Inhibit

This detects the condition of a missed embedded servo field detection, which causes a Write protect condition for the following data field, AND'ed with an attempt to write.

		PC	SPEC. NO.	SHEET	REV
		A	77641922	17	A

## PRODUCT SPECIFICATION - 9455 LMD

### 4.5 -contd.

#### 2. Write Gate AND Microcomputer Write Protect

This detects an attempt to write when Write protected by the micro-computer. The microcomputer may write protect when off-cylinder during seek, during command dialog, if a fault condition exists, if Fixed or Cartridge Write protect is active and the associated volume is selected, or when not Ready.

#### 3. Servo Write Protect Timing Fault

This checks internal embedded servo write protect timing. This guarantees the write protect is toggling and correct in time with respect to Read Enable, another Servo related signal.

#### 4. Read Gate AND Write Gate

The simultaneous occurrence of both Write Gate and Read Gate.

Under any of the following conditions, a write inhibit and an emergency retract of the heads is performed so that data is protected:

1. Loss of AC line power
2. Loss of spindle speed
3. Pre-amp faults
  - a. Write gate & no write data
  - b. Head shorted or open
  - c. Read active and DC write current
4. Servo Faults
  - a. +5, +16.5, -16.5 VDC failure
  - b. Retract capacitor charge low
  - c. Micro-computer detected fault

Protective features are incorporated within the LMD to prevent altering data due to abnormalities during start up or shutdown.

### 4.6 START/STOP TIME

Assuming that a cartridge has been inserted in the machine and no faults are present, the maximum time measured from actuation of start switch to ready and on cylinder status to controller is 120 seconds.

The maximum stop time measured from actuation of stop switch until cartridge can be removed is 60 seconds.

Upon a power loss, the maximum stop time is 120 seconds.

## 5.0 MEDIA CHARACTERISTICS

### 5.1 GENERAL

The media used on the LMD is an extension of the media used with existing module drive family. The coating thickness of the disk is optimized for high density magnetic recording with densities in excess of 7000 flux reversals per inch and track densities up to 600 tracks per inch with a diameter of approximately 8 inches.

		PC	SPEC. NO.	SHEET	REV
		A	77641922	18	A

PRODUCT SPECIFICATION - 9455 LMD

5.1 -contd.

A dedicated servo surface is not used with the LMD for head positioning control. Instead, embedded servo information is factory written on each data surface in those areas not occupied by header or data blocks. This pre-recorded servo field is used for carriage positioning, index and sector pulse generation, and PLO reference clock.

5.2 CARTRIDGE DESCRIPTION

The LMD cartridge contains an oxide coated single aluminum disk which is mounted on a self centering hub and enclosed in a protective plastic case. The cartridge will be sealed against dust such that when inserted into the drive, the dust cover will open automatically, for spindle and head access, and close automatically when withdrawn. A protective jacket is supplied with each cartridge to provide an additional safeguard against contamination or damage resulting from handling or storage.

Cartridge interchangeability between other LMDs using the same format and sector configuration will be insured.

A write protect TAB that is operator changeable will prevent inadvertant overwriting of data.

A cartridge is approximately 8.5 inches square and 1 inch in height. Reference Figure 8.

5.3 FIXED MEDIA DESCRIPTION

The fixed media is an iron oxide coated single aluminum disk attached to the spindle hub assembly. It is considered part of the basic drive and always remains within the assembly. Protection from damage and dirt is provided by housing it in a special cavity and isolating it from the cartridge receiving mechanism with a protective cover.

5.4 FIELD REPLACEMENT OF FIXED MEDIA

It is recommended that fixed media replacement be performed at a depot level maintenace facility or equivalent to insure the proper environmental control.

5.5 ALLOWABLE MEDIA DEFECTS

Media defects are characterized as being either correctable or uncorrectable as a function of the type and magnitude of the media flaw. Various error correction codes may be implemented to correct errors in the data read from the disk. However, the code chosen should be consistent with the media manufacturers media testing & certification methods. In the LMD,

		PC	SPEC. NO.	SHEET	REV
		A	77641922	19	B

## PRODUCT SPECIFICATION - 9455 LMD

### 5.5 -contd.

media certification is performed using the following standards:

- a. an error burst of 11 bits or less is a correctable error
- b. an uncorrectable error is one greater than 11 bits in length
- c. only one correctable error may occur in each sector or that sector must be classified as uncorrectable

A product characteristic of the LMD necessitates an addition to this criteria. A defect in an embedded servo area is classified as an uncorrectable media defect in the subsequent data field.

At the time of manufacture, media defect information is recorded in track 205, surface 0, and sector 0 of each disk. This identifies flagged track/sector data for those customers who wish to use it as part of a system initialization and track and/or sector de-allocation routine without re-certification (see example). If the customer wishes to use this information, it is imperative not to write on this area of disk until such time that it can be recovered.

Figure 7 shows the recording format for surface 0, track 205 and sector 0.

#### 5.5.1 LMD Fixed Media

The LMD fixed media will:

- a. Have no media defects on cylinder 0 or 205,
- b. Have no more than three correctable errors per surface,
- c. Have no more than two uncorrectable errors per surface,
- d. The total of b & c above must not exceed four errors.

This will permit those customers who have implemented ECC into their systems the use of 202 correctable tracks with 2 spares to be used as needed.

For those customers who choose not to use ECC, it is recommended that 200 tracks be used for data storage and retrieval, leaving 2 spares that can be assigned as alternates if this becomes necessary.

#### 5.5.2 LMD Cartridge Media

The magnetic recording surface of the LMD cartridge is the same as that of the fixed media. Media certification is performed using the same criteria. However, different grades of media are available. Refer to Disk Cartridge Product Specification 76192089 for further details.

## 6.0 ERROR RECOVERY CONSIDERATIONS

### 6.1 EARLY/LATE DATA STROBE

Consistent with media recording employing flux reversals in excess of 6000 FRPI, the LMD incorporates provisions to strobe the data window early or late to compensate for peak shifting due to bit crowding. This capability is controlled via a controller command and would normally be used when a read error occurs during reading as part of program controlled error recovery routine.

		PC	SPEC. NO.	SHEET	REV
		A	77641922	20	B

PRODUCT SPECIFICATION - 9455 LMD

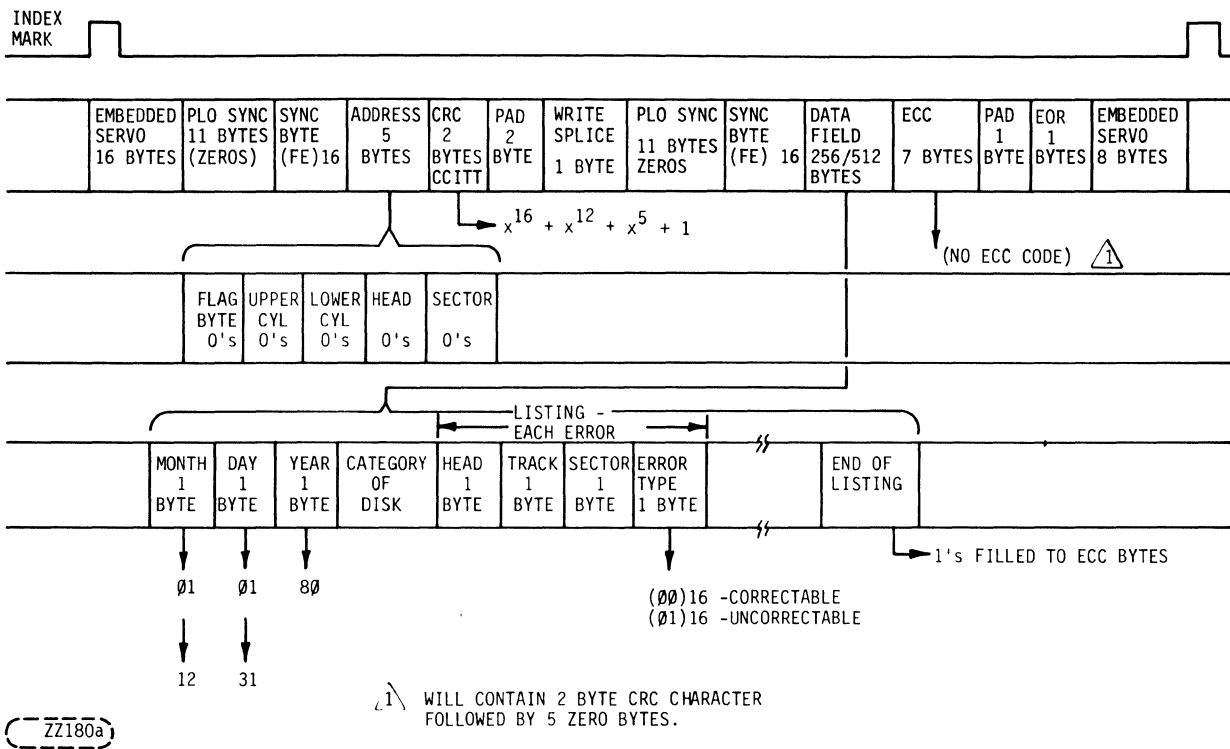
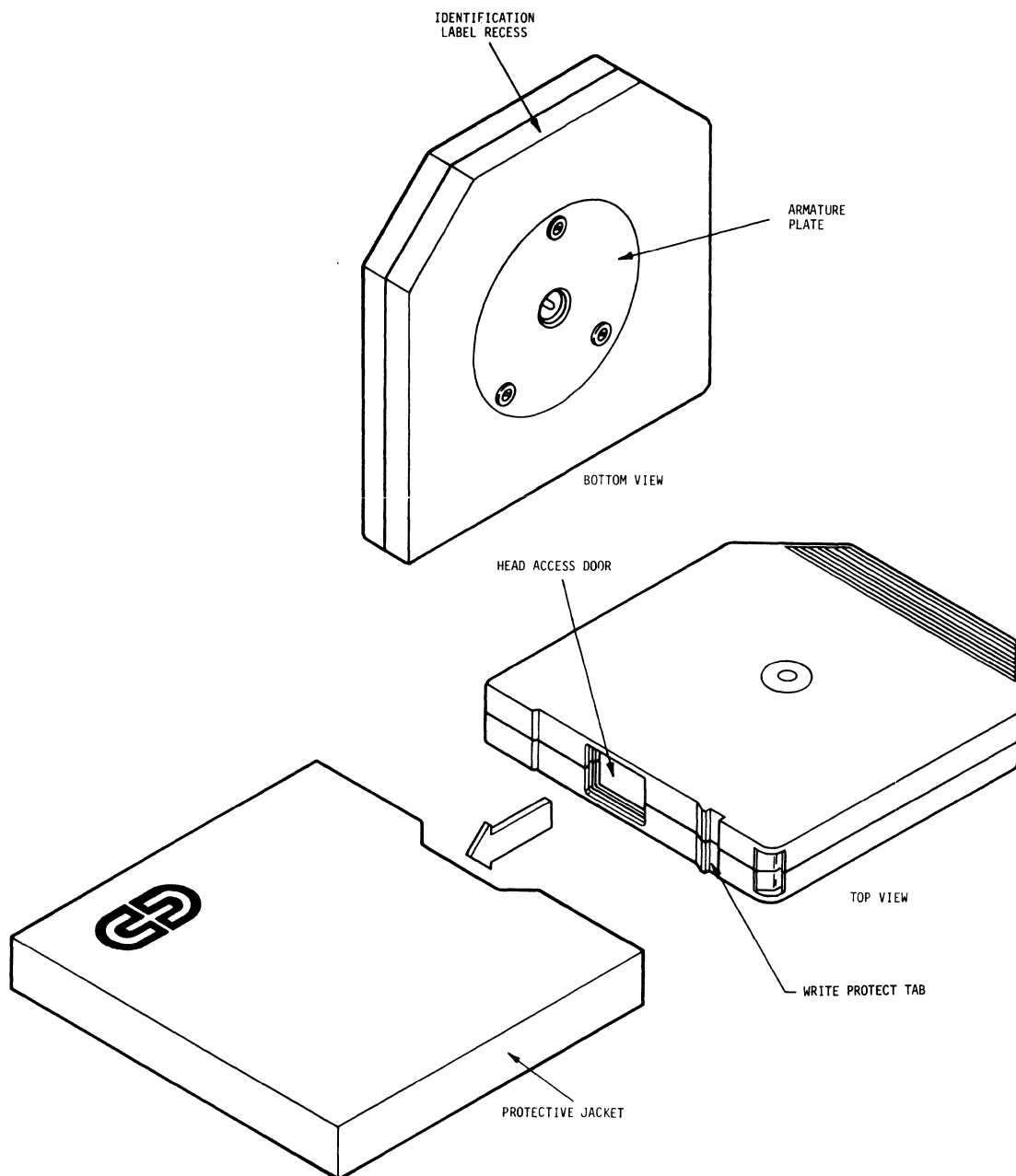

Figure 7. Format for Surface 0, Track 205, Sector 0 - Factory Flagged Track Data

		PC	SPEC. NO.	SHEET	REV
		A	77641922	21	A

PRODUCT SPECIFICATION - 9455 LMD



(Z71652)

Figure 8. Removable Cartridge

		PC	SPEC. NO.	SHEET	REV
		A	77641922	22	A

PRODUCT SPECIFICATION - 9455 LMD

6.2 ALTERNATE TRACK ASSIGNMENTS

The LMD has 206 tracks available per surface. Four of these are intended to be used as spares for alternate track assignments. Alternate track assignments may become necessary due to media defects that are uncorrectable (> 11 Bits) when using error correction codes. This will give the customer assurance that 202 flag free tracks will be available for data storage. Although ECC implementation is highly recommended for the state of the art recording technology used, those customers who require error free media without error correction capabilities may utilize these spare tracks as alternates for those that contain single or multiple bit errors. Since the probability of occurrence of error bursts > 11 bits is minimal as compared to single or multiple bit errors, optimum system efficiency would be realized using ECC techniques as opposed to alternate track assignments.

6.3 CRC/ECC IMPLEMENTATION

It is recommended with the LMD the customer should implement CRC/ECC error correction techniques. Although CDC manufactures the highest quality media known to the industry today, an economic trade off exists between the ability to produce error free media (which may not remain error free in use) and the need for the system to cope with media errors. The system designer should be aware of this as a consideration in ECC implementation.

Another factor to consider is the 2,9 recording method used. In MFM error bursts are directly proportional to the number of affected flux reversal positions therefore no error propagation occurs with media defects. In other words, N bad flux reversals on the recording surface equal N defective bits in the decoded data.

With the 2,9 recording method, incoming binary data passes through complex encoding circuitry and is written on the media in a coded fashion, i.e. three binary bits equal six possible flux reversal sites on the recorded media. Resultantly, a media defect in a current flux reversal sequence may propagate into adjacent flux reversal groups resulting in a decoded data error burst of greater length than the actual media defect.

7.0 RECORDING CHARACTERISTICS

7.1 RECORDING MODE

The recording system in the LMD employs CDC's 2,9 recording code. This code yields a bpi to frpi ratio of 1.5:1 such that a data track which was recorded using this code at 6000 frpi is effectively recording data on that track at 9000 bpi.

		PC	SPEC. NO.	SHEET	REV
		A	77641922	23	A

PRODUCT SPECIFICATION - 9455 LMD

7.1 -contd.

Briefly, in simplified form, this code operates in the following manner:

1. The NRZ serial data which is to be written on the disc is examined in a bit field form.
2. Within the 9 bit field each 3 bit sequence is encoded into a recorded zone containing not more than 2 flux reversals.
3. The presence or absence of a flux reversal and their placement within the zone is a function of the specific 3 bits of data to be written in the zone and the contents of the 2 zones which are immediately adjacent to the zone being written.

7.2 DISKS

Total number	2
Number/Cartridge	1
Number/Fixed	1
Number/Data surfaces	4
*Min. Data Tracks	808
Alternate Data Tracks	16
Total Track Capacity	
Unformatted Bits	165,376
Embedded Servo	
Bits/Sector	192

7.3 HEADS

Read/Write Number	4
-------------------	---

\*Does not include 4 spares per surface



		PC	SPEC. NO.	SHEET	REV
		A	77641922	24	A

PRODUCT SPECIFICATION - 9455 LMD

8.0 CONTROLS AND INDICATORS

8.1 OPERATOR CONTROL PANEL

The operator control panel contains two alternate action switches and two led indicators defined as follows:

Start Switch - When engaged, energizes the spindle motor provided:

1. The AC circuit breaker is ON.
2. The cartridge-door-closed switch is ON.
3. The cartridge-in-place switch is ON.
4. The hold line is at a low logic level or local mode switch is set.

When a fault condition exists, cycling the start switch from the "OFF" position to the "ON" position initiates the fault reset and recovery procedure.

Ready Indicator - Indicates unit ready status whenever the spindle is up to speed and the heads are loaded. The ready indicator blinks during the spindle start and stop procedures.

Fixed Protect Switch - When engaged inhibits all write operations on the fixed volume. (The removable volume is protected via an operator changeable write protect TAB which is sensed by the LMD electronics to prevent unwanted writing.)

Fixed Protect Indicator - Indicates that the selected volume is write-protected.

In addition to the above, the Fixed Protect Indicator also provides the operator with fault status information as follows:

1. Fixed Protect blinking indicates that a fault condition has been detected.

9.0 PHYSICAL CHARACTERISTICS

The following weights do not include shipping container or packaging.

9.1 MICRO-MODULE DRIVE (μMD)

Refer to Figure 9 for uMD dimensions and weight.

9.2 POWER AND INPUT/OUTPUT MODULE (PIO)

Refer to Figure 10 for PIO dimensions and weight.

		PC	SPEC. NO.	SHEET	REV
		A	77641922	25	A

PRODUCT SPECIFICATION - 9455 LMD

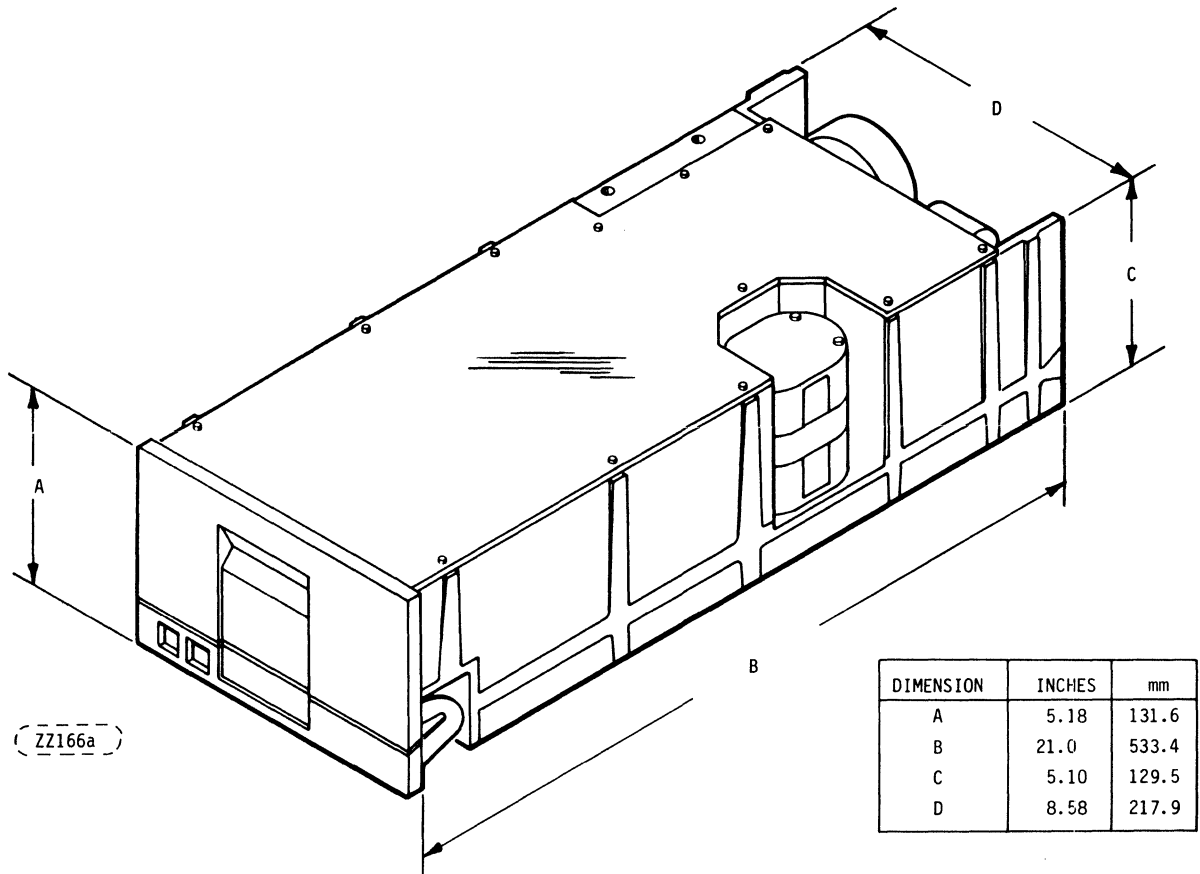

WEIGHT = APPROX. 40 lbs.

Figure 9.  $\mu$ MD Dimensions/Weight

		PC	SPEC. NO.	SHEET	REV
		A	77641922	26	A

PRODUCT SPECIFICATION - 9455 LMD

10.0 RELIABILITY AND SERVICE GOALS

10.1 MEAN TIME BETWEEN FAILURE

Following an initial period of 200 hours, the Mean Time Between Failure shall exceed 2400 hours for units manufactured in the first year or production and 4400 hours for units manufactured in the second year. For units manufactured after the second year, the MTBF shall exceed 6000 hours. The following expression defines MTBF:

$$MTBF = \frac{\text{Operating Hours}}{\text{No. of Equipment Failures}}$$

Operating hours means total power on hours less any maintenance time. Equipment failures means any stoppage or substandard performance of the equipment because of equipment malfunction, excluding stoppages or substandard performance caused by operator error, adverse environment, power failure, controller failure, cable failure, or other failure not caused by equipment. To establish a meaningful MTBF, operation hours must be greater than 5200 hours and shall include field performance data from all field sites.

For the purpose of this specification, equipment failures are defined as those necessitating repairs or replacements on an unscheduled basis. Essentially, the term equipment failure implies that emergency maintenance is required because of the hardware failure.

10.2 PREVENTIVE MAINTENANCE

No routine scheduled preventative maintenance shall be required provided the unit is operated in a clean office or computer room environment.

10.3 SERVICE LIFE

The device shall have a useful service life of five years or 20,000 hours, whichever occurs first, before requiring factory overhaul. Depot repair or replacement of major parts will be permitted during the lifetime.

		PC	SPEC. NO.	SHEET	REV
		A	77641922	27	A

PRODUCT SPECIFICATION - 9455 LMD

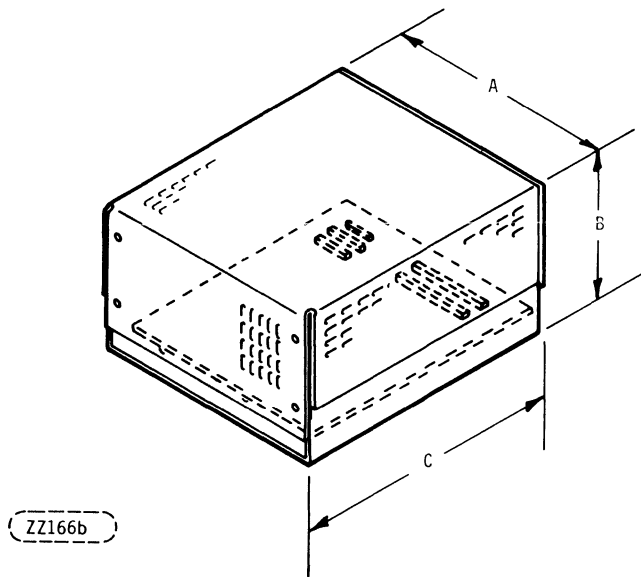

DIMENSION	INCHES	mm
A	8.58	217.9
B	4.63	117.6
C	8.5*	215
*DOES NOT INCLUDE FRONT PANEL		
WEIGHT - 15 lbs.		

Figure 10. Power Supply Module Dimensions/Weight

		PC	SPEC. NO.	SHEET	REV
		A	77641922	28	B

PRODUCT SPECIFICATION - 9455 LMD

11.0 INSTALLATION AND MAINTENANCE

The maintenance philosophy for the LMD is module (PIO or  $\mu$ MD) replacement with depot or factory repair. This is facilitated by the small size and light weight of the modules.

NOTE

The  $\mu$ MD has a factory installed top cover providing maximum protection from environmental contaminants. This cover should only be removed in a recommended maintenance facility with proper environmental control; otherwise warranty will be void.

Required connections to the device are power, signal cables and a system ground consistent with normal peripheral equipment grounding practices. The physical requirements are adequate clearances for maintenance and air intake/exhaust.

11.1 POWER REQUIREMENTS

11.1.1 Primary Requirements

The primary voltage and current requirements are shown in Tables 2 and 3.

Table 2. Primary Voltage Requirements

VOLTAGE (VAC)	TOLERANCE (VAC)	FREQUENCY (Hz)	TOLERANCE (Hz)
120	+8, -16	60	+0.5, -1.0
220	+15, -29	50	+0.5, -1.0
230	+16, -32	50	+0.5, -1.0
240	+16, -32	50	+0.5, -1.0

		PC	SPEC. NO.	SHEET	REV
		A	77641922	29	B

PRODUCT SPECIFICATION - 9455 LMD

Table 3. Current/Power Requirements Under Various Conditions

DRIVE INPUTS	CURRENTS AND (WATTAGE)					
	ON TRACK		SEEKING		STARTING	
	NOMINAL	MAXIMUM	NOMINAL	MAXIMUM	NOMINAL	MAXIMUM
120 VAC	0.5 A (60 W)		0.5 A (60 W)		0.85 A (102 W)	
+16.5 VDC	0.4 A (6.6 W)		0.72 A (11.9 W)		—	—
-16.5 VDC	0.35 A (5.8 W)		0.67 A (11.1 W)		—	—
+5 VDC	0.91 A (4.55 W)		0.91A (4.55 W)		—	—
-5 VDC	2.88A (14.4 W)		2.88A (14.4 W)		—	—
TOTAL WATTAGE	(91.1 W)		(102 W)		—	—
I/O INPUTS						
+5.0 VDC	0.9 A (4.5 W)		0.9 A (4.5 W)			
-5.0 VDC	0.3 A (1.5 W)		0.3 A (1.5 W)			
TOTAL WATTAGE	(6.0 W)		(6.0 W)			
POWER SUPPLY INPUTS	RUN CURRENT		START CURRENT		START TIME (SECONDS)	
	NOMINAL	MAXIMUM	NOMINAL	MAXIMUM	NOMINAL	MAXIMUM
120 VAC	1.15 A (138 W)		1.45 A (174 W)		60	

OPERATIONAL PROFILE

- T1 - BREAKER ON
- T2 - SPINDLE BRAKE ON
- T3 - SPINDLE BRAKE OFF
- T4 - SPINDLE START
- T5 - SPINDLE AT SPEED
- T6 - HEAD LOAD
- T7 - START SEEK (MAX POWER)
- T8 - END SEEK (MAX POWER)
- T9 - RETURN TO ZERO TRACK
- T10 - PUSH/STOP (RETRACT)
- T11 - SPINDLE OFF
- T12 - SPINDLE BRAKE ON
- T13 - SPINDLE BRAKE OFF
- T14 - BREAKER OFF

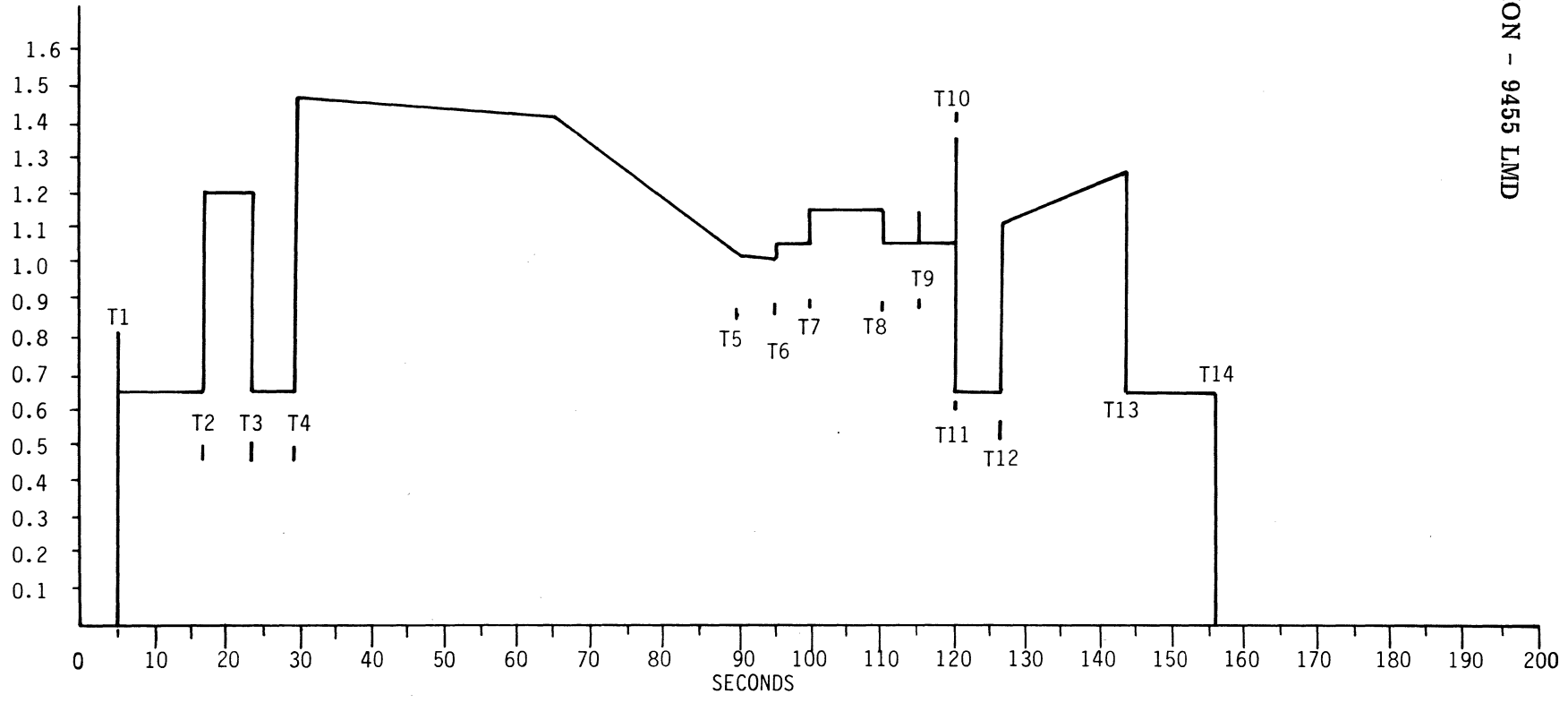

Figure 11. Operational Nominal Line Currents to Power Supply vs Time

	A	PC	SPEC. NO.
	77641922		
	30	SHEET	REV
	B		

		PC	SPEC. NO.	SHEET	REV
		A	77641922	31	B

PRODUCT SPECIFICATION - 9455 LMD

11.2 GROUNDING

A low impedance ground strap shall be connected between the power supply DC grounds of the controller and 9455.

11.3 ENVIRONMENTAL LIMITS

The LMD is intended to operate in computer room and office environments.

11.3.1 Temperature

a. Operating

50° F (10.0° C) to 104°F (40°C) with a maximum gradient of 18°F (10°C) per hour. Maximum operating temperature should be reduced as a function of altitude by 1.95°F/1000 ft.

b. Transit Temperatures

-40.4°C (-40°F) to 70.0°C (158°F) with a maximum gradient of 20°C (36°F) per hour. This specification assumes that the LMD is packaged in the shipping container designed by MPI for use with the LMD.

c. Storage Temperature

-10°C (+14°F) to 50.0°C (122°F) with a maximum gradient of 15.0°C (27°F) per hour.

In the event that it becomes necessary to use a LMD Cartridge which has not been allowed to stabilize at the ambient LMD input temperature for at least one hour or; a cartridge which was exposed to temperatures below 16°C immediately prior to the stabilization period then the following procedures must be employed:

- a. the cartridge must be visually inspected or examined to insure that condensation is not present on any part of cartridge and;
- b. the cartridge must be allowed to spin on the LMD for a period of not less than five minutes prior to attempting to read or write on that cartridge.

11.3.2 Relative Humidity

Operating

20% to 80% RH (providing there is no condensation) with a maximum gradient of 10% per hour.

Transit (as packed for shipment)

5% to 95% (providing there is no condensation).



		PC	SPEC. NO.	SHEET	REV
		A	77641922	32	B

PRODUCT SPECIFICATION - 9455 LMD

11.3.2 -contd.

Storage 10% to 90% (providing there is no condensation).

11.3.3 Altitude (actual or effective)

a. Operating

983 ft (300 m) below sea level to 6560 ft (2000 m) above sea level.

b. Transit (as packed for shipment)

983 ft (300 m) below sea level to 8200 ft (2500 m) above sea level.

11.3.4 Vibration and Shock

a. Equipment, as normally installed and positioned, shall meet the full specified performance while subject to the following conditions injected from the floor in a vertical direction.

1. Continuous vibration as indicated in Figure 9. "Operating" curve A.
2. Intermittent shocks of up to 2 g and not exceeding 10 ms in duration. No shock is to be repeated more often than two per second.

NOTE

The above shock and vibration limits are assumed to be measured directly at the uMD or the PIO. If the equipment is installed in an enclosure to which the stated shock/vibration criteria is applied, resonances may occur internally to the enclosure resulting in vibrations in excess of these limits. In this case it may be necessary to add shock absorbers to the enclosure.

b. Transit (as packed for shipment)

Equipment in its normal upright position shall withstand the conditions of vibration and shock injected from the floor in the three major mutually perpendicular axes.

1. Vibration as shown in Figure 11. Transit (as packed for shipment).
2. Shocks of up to 5 g, not exceeding 10 ms in duration. The time between consecutive shocks cannot be less than 5 seconds.

11.3.5 Air Cleanliness

The LMD is designed for operation in working Range #3 of CDC Standard 1.03.205. This describes, what is considered to be, a typical office environment as it relates to air contamination. In this environment the LMD will operate with the following levels of contamination:

- a. Particle sizes greater than 1.0 microns-concentration of  $4 \times 10^7$  particles per cubic meter.
- b. Particle sizes greater than 1.5 microns-concentration of  $4 \times 10^6$  particles per cubic meter.
- c. Particle sizes greater than 5.0 microns-concentration of  $4 \times 10^5$  particles per cubic meter.

		PC	SPEC. NO.	SHEET	REV
		A	77641922	33F	B

PRODUCT SPECIFICATION - 9455 LMD

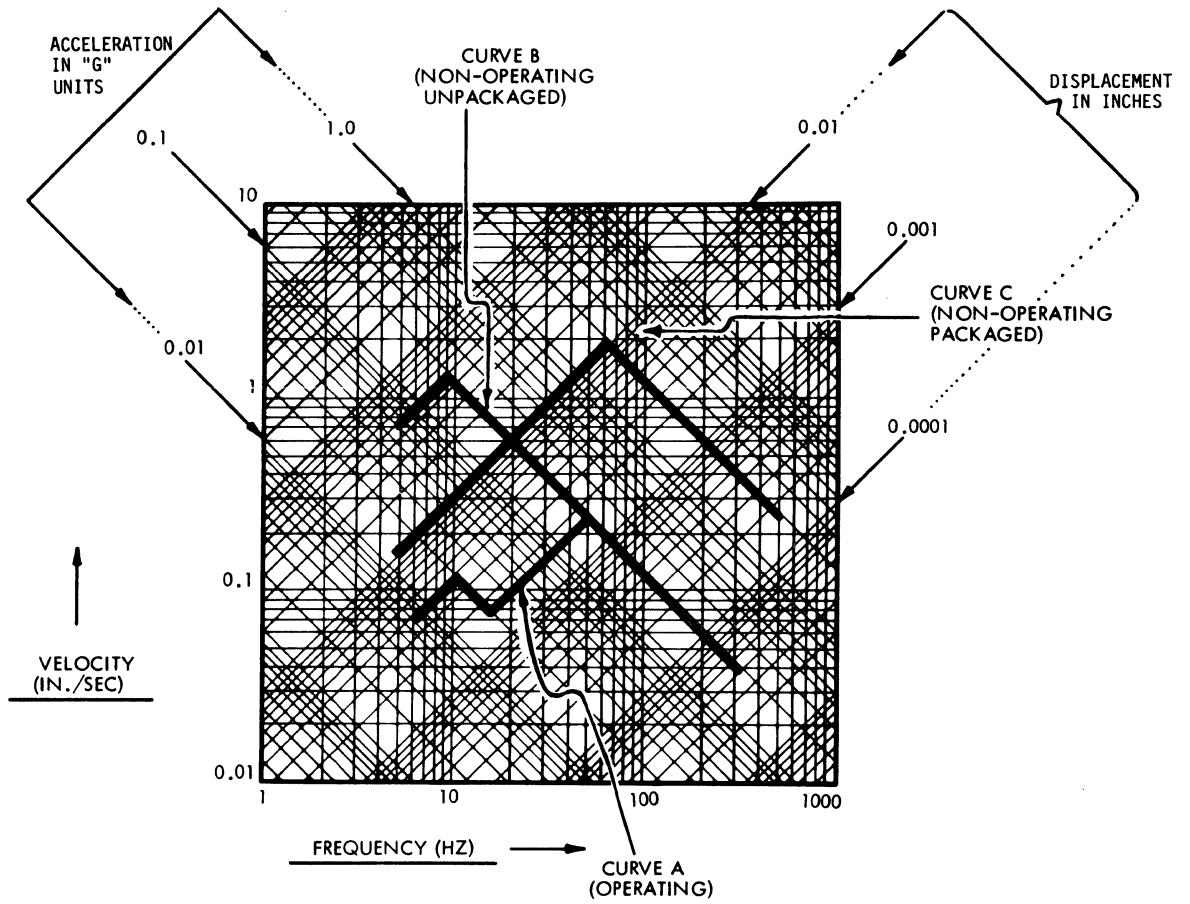

Z097b

Figure 12. Vibration Levels

