

 **Intecolor**[®]
AN INTELLIGENT SYSTEMS COMPANY

225 Technology Park/Atlanta • Norcross, GA 300921 • Telephone 404/449-5961 • TWX 810-766-1581

USER'S MANUAL

for the

INTECOLOR 2405 TERMINAL

999378

10/16/83

V.-2.7/2.8

WARNING

This equipment generates, uses, and can radiate radio frequency energy and may cause interference to radio communications if not installed and used in accordance with the instructions in this manual. The equipment's radio frequency emissions have been measured and found to be within the limits established in FCC Rules, Part 15, Subpart J, for Class A computing devices. These rules are designed to limit interference by such devices to levels considered reasonable for commercial environments. If the user operates this equipment in a residential environment he will be likely to cause interference for which he can be required to take corrective action at his own expense.

CCR

Intecolor Corporation
225 Technology Park/Atlanta
Norcross, Georgia 30092
Telephone: 404/449-5961
TWX: 810/766-1581

Copyright (C) 1983 by Intecolor Corporation. All rights reserved.

NOTICE

The contents of this publication may not be reproduced in any form by any means without the prior written consent of the Intecolor Corporation.

Neither the Intecolor Corporation, nor its parent company, Intelligent Systems Corporation assumes any responsibility for errors or omissions which may appear in this document or any liability for loss or damage resulting from the use of information contained in it. The Intecolor Corporation reserves the right to revise this document and to make changes in its content without obligation to notify any person of such revisions or changes.

No warranty of any kind is made or implied with regard to the firmware described in this document and to its merchantability and fitness for a particular purpose. This firmware is furnished under a license agreement and may be used only in accordance with the terms of the agreement.

This printing of the 2405 User's Manual has been revised to cover software versions up to and including V2.8.

To report errors in the manual or software bugs, please complete and return the Software Problem Report form at the back of the manual.

VT52TM is a trademark of Digital Equipment Corp., Maynard, Massachusetts.

Copyright (C) 1983 by Intecolor Corporation. All rights reserved.

TABLE OF CONTENTS

PART ONE: INTRODUCTION TO THE 2405	1.1
OVERVIEW	1.1
MODES OF OPERATION	1.3
DISPLAY CAPABILITIES	1.4
Display Organization	1.4
Character Sets	1.6
Screen Saver	1.6
THE KEYBOARD	1.7
Special Purpose Keys	1.9
Alphanumeric Keys	1.11
Keys which Generate ASCII Control Codes	1.13
Function Keys	1.14
PF (Private Function) Keys	1.15
Numeric Keypad Keys	1.16
Cursor Control Keys	1.16
TERMINAL CONTROLS AND INDICATORS	1.18
Power Switch and Line Fuse	1.18
Audible Indicators	1.18
PART TWO: INSTALLATION, INTERCONNECTION AND POWER-UP	2.1
UNPACKING AND INSPECTING A NEW TERMINAL	2.1
THE OPERATING ENVIRONMENT	2.1
POWER-UP AND PRELIMINARY TESTING	2.3
Initial Test	2.4
INTERCONNECTION	2.6
PART THREE: SETUP, TESTING AND ON-LINE OPERATION	3.1
SETTING UP THE TERMINAL	3.1
Items on the Main Setup Menu	3.3
Summary of Terminal Setup Options	3.11
HOST-TERMINAL COMMUNICATIONS	3.11
Software Handshaking	3.11
Terminal Control Codes	3.12
THE TERMINAL'S SELF-TEST CAPABILITIES	3.14

PART FOUR: OPERATION IN THE ANSI X3.64 MODE	4.1
ANSI CONTROL SEQUENCES	4.1
Command Structure	4.1
Examples of Valid ANSI Sequences	4.2
A Note on Erroneous Commands	4.3
ANSI X3.64 COMMAND SEQUENCE LISTING	4.5

PART FIVE: VT52 MODE OPERATION	5.1
COMMAND SEQUENCES WHICH REPLACE ANSI SEQUENCES	5.1
NEW COMMAND SEQUENCES	5.2
ALTERNATE KEY CODES	5.2

APPENDICES

THE ASCII CODE	A.1
GLOSSARY OF TERMS (ANSI)	B.1
TERMINAL CONTROL CODES	C.1
SUMMARY OF ANSI SEQUENCES - By Mnemonic	D.1
SUMMARY OF ANSI SEQUENCES - By Function	E.1
SUMMARY OF ANSI SEQUENCES - By Code	F.1
TECHNICAL SPECIFICATIONS FOR THE 2405	G.1
LIGHT PEN OPERATION	H.1

SCHEMATIC DIAGRAMS

2405 Character Set	102307
Keyboard	101953
CPU, Program Memory and I/O	101959, sheet 1
Display Memory and Display Generator	101959, sheet 2
Interconnecting Wiring	101962
Analog	101965
Video Amplifiers	101976

SOFTWARE PROBLEM REPORT

Figures in the Text

<u>Figure</u>	<u>Description</u>	<u>Page</u>
1.1	Functional Block Diagram	1.2
1.2	Display Organization	1.5
1.3	Keyboard Layout	1.8
3.1	Main Setup Menu	3.2
3.3	Horizontal Tabs	3.8

Tables in the Text

<u>Table</u>	<u>Description</u>	<u>Page</u>
1.4	Alpha Key Codes	1.11
1.5	Numeric and Punctuation Key Codes	1.12
1.6	Keyboard Generation of Control Codes	1.13
1.7	Default Assignments for Function Keys	1.15
1.8	PF Key Codes	1.15
1.9	Numeric Keypad Key Codes	1.16
1.10	Cursor Key Codes	1.17
2.1	Keyboard Connector Pin Assignments.	2.6
2.2	Host Connector Pin Assignments	2.7
2.3	Printer Connector Pin Assignments	2.7
2.4	Light Pen Connector Pin Assignments	2.8
3.2	Baud Rates	3.7
3.4	Terminal Control Codes	3.13
4.1	PUI, SS2 and SS3 Sequences	4.34-ff

PART ONE

PART ONE: INTRODUCTION TO THE 2405

OVERVIEW

The Intecolor 2405 is a data terminal, a device which an operator uses to communicate with a host computer and to control auxiliary equipment like printers and plotters.

Though they are physically unified, the 2405's components have two logically distinct functions. The keyboard acts as an input device for the host computer, while the display screen acts as an output device for the host computer. These two devices can function in a simultaneous and independent fashion. Data can be transmitted from the keyboard to the host while different data are transmitted from the host to the display. This type of operation is called full duplex.

The 2405 belongs among those terminals which are popularly characterized as "intelligent" because they have computing capabilities of their own. These capabilities are provided by microelectronic devices, in particular by large scale integrated circuits which function as processors and memories. In general, the presence of such capabilities at the terminal is doubly advantageous: first, because the host's workload can be minimized (especially important in time-sharing situations); second, because host programming can be considerably simplified.

The 2405's computing capabilities allow it to respond to commands which are very simple in form, yet require very complex operations for their execution. The operations of which the terminal is capable include all those needed to construct multicolored displays of text and/or graphs from data supplied according to either of two protocols. These protocols include the device independent and otherwise very flexible ANSI Standard X3.64 protocol, and the widely used DEC VT52 protocol.

The 2405's main functional elements are represented in the diagram on the next page (Figure 1.1). Data enter and leave the terminal in serial form through two bidirectional ports. One of these ports is used for the keyboard and for a printer. The other is used for the host.

Within the terminal, data are handled eight bits in parallel by a microprocessor. Associated with the processor is a read-only program memory and a read/write Setup memory, which stores the values defining terminal operating conditions such as baud rate, type of parity, etc. This

Introduction

memory is equipped with a battery which permits it to remember settings between operating sessions.

The processor can read or write data at a two page display memory. Data from the memory is used by a display generator to construct video and sync signals. The video signals control the operation of three electron guns in the CRT. The sync signals control the production of signals which deflect the electron beams produced by the guns to produce a raster scan of the display screen. (Further information about display capabilities is provided on the following pages.)

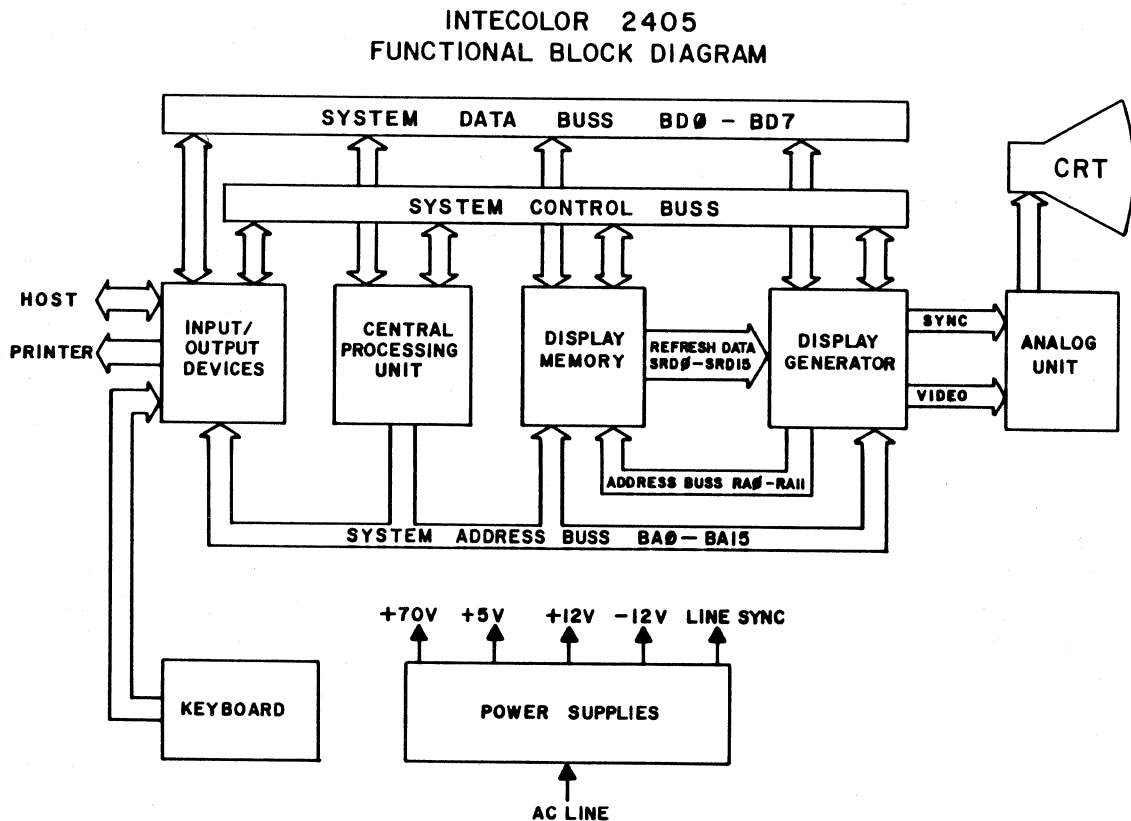

(Figure 1.1)

MODES OF OPERATION

- Setup Mode

A local mode of operation, entered from the keyboard. Used to select the values of parameters governing host/terminal communications (baud rate, parity, etc.) and other operating conditions, and to check status.

The terminal's display unit provides a Setup Menu representing current conditions. Menu items are selected from the keyboard.

- ANSI X3.64 Mode

An on-line mode, full duplex, with selectable local echo, entered at power-up (when the terminal is appropriately set up), from Setup Mode, or from VT52 mode upon receipt of an appropriate command from the keyboard or the host.

The terminal's display represents a page of text having 24 lines, 80 characters per line, or a graphic coordinate system with limits defined by the points (0,0) and (159, 95).

- VT52 Mode

An on-line mode, full duplex, with selectable local echo, entered at power-up (when the terminal is appropriately set up), from Setup Mode or from ANSI Mode following receipt of an appropriate command from the keyboard or host.

Display capabilities are the same as those for ANSI Mode.

- Self-test Mode

A local mode, entered automatically at terminal power-up and upon the receipt of an appropriate command from the keyboard or host.

The screen is used to display test patterns and error messages. When no error is found, the terminal reverts automatically to one of its other modes.

DISPLAY CAPABILITIES

The method used to create displays involves the electronic division of the display area on the screen to form a matrix of cells in which characters or plot blocks can be represented.

Display Organization

The dimensions of the character cell matrix are 80 character cells horizontally and 24 character cells vertically. Accordingly, the display area can represent a page of text having 24 lines, each line having up to 80 characters. In graphic displays, each character cell represents some combination of up to 8 plot blocks. A graph is constructed of plot blocks on an (x,y) coordinate system in which x is an integer between 0 and 159 and y is an integer between 0 and 95.

Each character cell resolves to a 6 x 12 pixel matrix, in which characters and plot blocks are represented as patterns of colored dots. Each character cell as a whole is treated as an element of the display. A memory register is assigned to each character cell, whose content is defined by a data word written into the associated register.

The address of each memory register corresponds to the position of a character cell in the display area, and the memory furnishes the standard resolution display generator with a sequence of data words in step with the progress of the sweep of the CRT's beams from cell to cell over the screen.

The data words stored in the memory array define the contents of the character cells in two ways. On the one hand, they single out characters from the terminal's character set or plot block set.

On the other hand, they determine a background and foreground color combination for the display of the selected character or plot block(s) and the blink or underscore attribute of the character. Eight background and eight foreground colors are displayable.

The data words held in memory do not represent directly the dot patterns and dot colors which represent characters and plot block groups. Instead, they point to registers in read-only memories where a code for each displayable character and color combination is permanently stored. Accordingly, when the contents of the standard resolution display memory are changed, the content of an entire character cell, i.e., a character and/or color, is changed.

Color control is possible with ANSI sequences and with the FG/BG key, used in combination with keys Q, W, E, R, T, Y, U and I. (See the SGR sequences described in Part Four and the keyboard description below for further information.)

The size of the 2405's character cell matrices permits the display of the ASCII characters with standard resolution and, in addition, the display

of those lower case characters which have descenders in their proper relations to the other characters.

Character Sets

The character set includes the 96 uppercase and lowercase ASCII characters, 32 control code symbols and 32 special graphics characters. The complete character set is represented on a fold-out chart (drawing #102307) included in the appendices.

The control code symbols are displayable only following the issuance of a special ANSI control sequence. When the terminal is in the Control Representation Mode both ASCII control codes and longer control sequences are represented on the screen, but these codes and sequences are not otherwise acted on by the terminal processor. (See the CRM sequences.)

Switching between the ASCII lowercase characters and the special graphics characters is done in response to <SO> and <SI> control codes, issued by the host or from the keyboard (when local echo is selected). The ASCII uppercase characters are always available. (See the ANSI SCS sequences for further information.)

Graphs constructed of plot blocks can be displayed in response to ANSI command sequences which cause points and lines to be drawn. (See the PLOT commands.) Plot blocks resolve to 3 x 3 dots, and there can be up to eight blocks in a character cell. Blocks can be plotted one at a time, but they are handled by the display generator as groups of one to eight, like characters. Accordingly, when a new block is to be displayed within a given character cell, the contents of the entire cell are changed. For example, if a group of two blocks is already displayed in the given cell it is replaced with a group of three blocks having the proper positions relative to one another. This means that the colors of the blocks are not independently controllable.

The 2405 contains two memory arrays which are dedicated to character cell graphics; each array can hold enough data to define one complete display. Normally, one page of memory is used for the Setup Mode menu and the other is used for normal display; accordingly, switching to Setup Mode does not involve the loss of data.

Screen Saver

A CRT (cathode ray tube) such as that used in the 2405 is subject to damage by the prolonged display of a fixed image on its screen. Such display tends to "burn" the image into the screen's phosphors.

The 2405 has automatic equipment which is designed to prevent this kind of damage and thereby prolong the life of the CRT by limiting the time a given image can be displayed on the screen. A display which is not changed within a period of ten minutes is automatically turned off. The display returns as soon as there is any activity from the host or keyboard.

The screen saver equipment may be enabled or disabled by means of Setup Mode commands.

THE KEYBOARD

The keyboard is used to generate codes which are transmitted either to the host computer alone (on-line operation with no local echo), to the display unit alone (off-line or local operation), or to both host and display unit (on-line operation with local echo). These codes are ASCII binary equivalents of characters and control symbols or of groups of these characters and control symbols.

Within the terminal, the keyboard is assigned a buffer where keystrokes are recorded until the proper codes can be generated and sent to the host computer. If the processing of keystrokes is slowed down or held up while the operator continues typing, the buffer can fill up. If this occurs, an audible indication is given each time a new key is pressed and the keystroke is ignored. When the terminal has had time to process some of the keystrokes in the buffer new keystrokes are again accepted. A buffer overflow is very unlikely to occur unless the Repeat key is held down.

The standard 2405 keyboard is built in to the cabinet and is connected to the terminal electronics by a cable and telephone type plug which is accessible from the rear of the unit. The 2405D has a detached keyboard which is connected to the terminal with a coiled cable terminated with a standard telephone type plug.

To insure proper operation, the keyboard cable should be securely plugged into the terminal before power is applied. If the cable plugged in while the terminal is under power the keyboard might not operate properly.

Several versions of the keyboard are available. These versions differ mainly with respect to the number of programmable function keys (F0-F23) installed and to the keys assigned color control functions. Keyboards supplied with terminals having V2.1 through V2.4 software have either twelve or twenty-four function keys, of which the first seven are marked with color codes and are used in conjunction with the BG/F key for display color control. Keyboards supplied with terminals having V2.5 through V2.7 software have color codes on alphabetic keys Q through I and may have zero, twelve or twenty-four function keys.

The keys are arranged in three major groups. The group of keys to the operator's right is used to control the display cursor, a blinking line or other visible sign which marks the position at which the next display operation will begin.

2405 Keyboard Layout

(Figure 1.3)

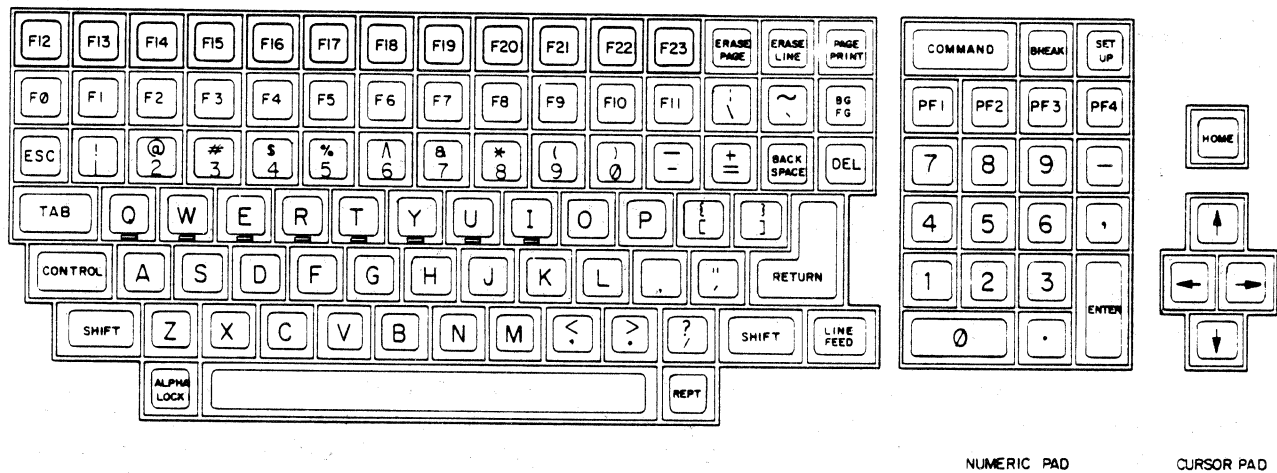

The keys grouped immediately to the left of the cursor pad are arranged in six rows. The top two rows contain special purpose keys whose special functions are discussed below. The bottom four rows constitute a numeric keypad similar to those found on standard office machines.

The main keypad includes alphabetic and numeric keys organized like the keys on a standard typewriter. These keys have grey caps. When installed, the programmable function keys are situated above the alphanumeric keys in one or two rows. Many of the remaining keys have special functions which are described below.

The functions of the various keys on the keyboard are described on the following pages in detail under the following headings:

- Special Purpose Keys
- The Alphanumeric Keys in the Main Keypad
- Keys Which Generate ASCII Control Codes
- Function Keys (F0 - F23)
- PF (Private Function) Keys
- Numeric Keypad Keys
- Cursor Control Keys

Special Purpose Keys

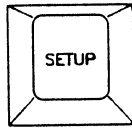

The Setup key is operated while holding down either of the Shift keys in order to place the terminal in its Setup Mode or to take it out of this mode.

This key is used by itself to enable operation of the keyboard when it has been disabled by a command from the host or by the terminal's Self-test program.

This key never transmits a code to the host.

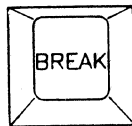

When the Break key is operated, the transmission line to the host is pulled to a logical low state for 0.2333 seconds (with a ten-percent variation) and any operation being performed by the terminal processor (scrolling the display, for example) is interrupted.

The operation of this key has no effect when the keyboard has been disabled.

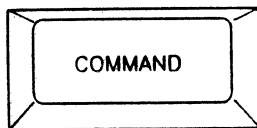

The Command Key is used in conjunction the alphanumeric keys to generate Escape sequences that may be assigned functions by the host program. The key is used by holding it down while striking another key. When operated by itself it generates no code.

The sequences generated when this key is used begin with <ESC>O. For example, the combination (Command P) gives the following sequence: <ESC>OP

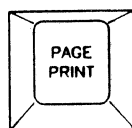

The Page Print key is used to transfer the contents of a display to a printer without altering the display. It sends the following Media Copy (MC) command sequence: <ESC>[0i

This key can be used when the terminal is operating in any mode.

Introduction

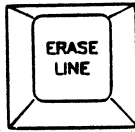

The Erase Line key is used to erase the contents of the display from the cursor position to the end of the line. It sends the following Erase Line (EL) command sequence: `<ESC>[0K`

This key can be used only when the terminal is operating in the ANSI X3.64 Mode (local or remote echo enabled).



The Erase Page key is used to erase the display from the cursor position to the end of the page. The key generates the following Erase Display (ED) command sequence: `<ESC>[0J`

This key can be used only when the terminal is operating in the ANSI X3.64 Mode (local or remote echo enabled).

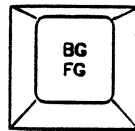

The FG/BG key is used to change the colors with which characters and plot blocks are displayed. Color change is accomplished by striking this key and then one of the following alphabetic keys: Q,W,E,R,T,Y,U,I (or, in some units, keys F0-F7). These keys represent the colors black, red, green, yellow, blue, magenta, cyan, and white respectively. Only characters displayed subsequently, beginning at the current cursor position are affected.

Used unshifted with one of the color coded keys, the FG/BG generates an ANSI SGR foreground color control sequence. Shifted, FG/BG generates an ANSI SGR background color control sequence. When the terminal is on line the SGR sequences must be echoed locally or by the host before they can be acted upon.

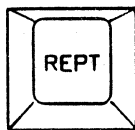

The Repeat key may be held down together with another key in order to transmit repeatedly the code or code sequence generated by that key.

If this key is used to generate a very long string of codes while the terminal is operating at a low baud rate the keyboard buffer could overflow. Therefore, the terminal is equipped with a repeat rate controller, which lowers the repeat rate automatically if the buffer fills to a certain point. (See the PRKC commands.)

The Alphanumeric Keys in the Main Keypad

The alphanumeric keys (including the space bar), with grey caps, generate the ASCII codes for the uppercase and lowercase alphabetic characters, numerals and punctuation marks. When these codes are returned to the terminal, either locally or by the host, they can cause the display of the characters. In certain modes of operation, these keys can be used to display special graphics characters.

On some terminals the keys Q, W, E, R, T, Y, U and I are marked with colored bars. (Others have colored bars on the function keys F0-F7.) The color coded keys can be used in conjunction with the FG/BC key to generate ANSI SGR sequences for changing the colors of the display.

Operated by themselves, the alphanumeric keys generate the lowercase ASCII codes. They are commonly used in conjunction with three other keys, the two Shift keys and the Alpha Lock key, to produce the uppercase codes.

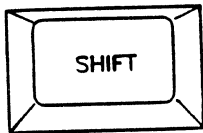

The two Shift keys are used interchangeably in conjunction with other keys to generate the uppercase ASCII codes. All the alphanumeric keys except for the Space Bar and DEL are affected by the Shift keys. The Shift keys are used by holding either of them down while operating another key. By themselves they generate no code.

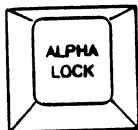

The Alpha Lock key, when engaged, makes all the alphabetic keys uppercase. It does not affect numeric and special character keys.

The codes generated with the alphabetic keys are given in the table below as hexadecimal numbers.

Alpha Key Codes - (Table 1.4)

<u>Key</u>	<u>Shifted</u>	<u>Unshifted</u>	<u>Key</u>	<u>Shifted</u>	<u>Unshifted</u>
A	41	61	N	4E	6E
B	42	62	O	4F	6F
C	43	63	P	50	70
D	44	64	Q	51	71
E	45	65	R	52	72
F	46	66	S	53	73
G	47	67	T	54	74
H	48	68	U	55	75
I	49	69	V	56	76
J	4A	6A	W	57	77
K	4B	6B	X	58	78
L	4C	6C	Y	59	79
M	4D	6D	Z	5A	7A

Introduction

The codes generated with the numeric and punctuation keys are given in the table below as hexadecimal numbers.

Numeric and Punctuation Key Codes - (Table 1.5)

Key	<u>Shifted</u>	<u>Unshifted</u>	Key	<u>Shifted</u>	<u>Unshifted</u>
! /	21	31	_ -	5F	2D
@ 2	40	32	+ =	2B	3D
# 3	23	33	\	7C	5C
\$ 4	24	34	~ `	7E	60
% 5	25	35	{ [7B	5B
^ 6	5E	36	}]	7D	5D
& 7	26	37	: ;	3A	3B
* 8	2A	38	" '	22	27
(9	28	39	< ,	3C	2C
) 0	29	30	> .	3E	2E
Space Bar	20	20	? /	3F	2F
DEL	7F	7F			

The Keys which Generate ASCII Control Codes

The alphabetic keys and certain other keys can be used in conjunction with the Control key to generate the ASCII control codes. The control codes are distinguished from the character codes because they are not normally associated with displayable characters and usually signal special operations within the system.

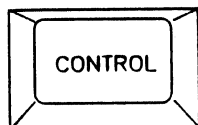

The Control key is used by holding it down while operating another key or keys. It generates no code of its own.

The table below shows how the various control codes are generated. The position of the Alpha Lock has no bearing on the generation of the control codes. However, certain keys must be Shifted, as noted.

Keyboard Generation of Control Codes - (Table 1.6)

Control + Key	Mnemonic	Hex	Control + Key	Mnemonic	Hex
@*	NUL	00	P	DLE	10
A	SOH	01	Q	DC1 (XON)	11
B	STX	02	R	DC2	12
C	ETX	03	S	DC3 (XOFF)	13
D	EOT	04	T	DC4	14
E	ENQ	05	U	NAK	15
F	ACK	06	V	SYN	16
G	BEL	07	W	ETB	17
H	BS	08	X	CAN	18
I	HT	09	Y	EM	19
J	LF	0A	Z	SUB	1A
K	VT	0B	[ESC	1B
L	FF	0C	\	FS	1C
M	CR	0D]	GS	1D
N	SO	0E	^*	RS	1E
O	SI	0F	_*	US	1F

*Shifted Key

Introduction

Control symbols can be represented on the screen following the issuance of special commands. (See the CRM commands for further information.)

Special keys are included for generating certain very frequently used control codes by means of single key operations.

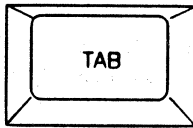

This key can be used instead of the (Control I) combination. It sends the ASCII horizontal tab code <HT>.

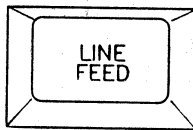

This key is used instead of the (Control J) combination to send the line feed code <LF>. When held down, it sends the code repeatedly.

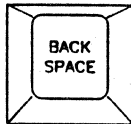

This key is used instead of (Control H) to send the ASCII back space code <BS>. When held down it sends the code repeatedly.

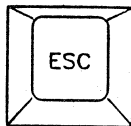

This key is used instead of (Control []) to send the ASCII Escape code <ESC>. This code is often used in command and control sequences. Such sequences can be formed by striking the Escape key and then the other key or keys needed.

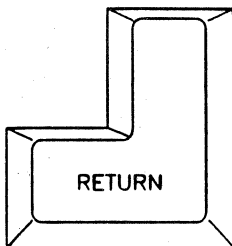

This key is used instead of the (Control M) combination to send the ASCII carriage return code <CR>.

Function Keys

Each of the optional keys labeled F0 through F23 can be programmed by the user to send sequences of up to 40 ASCII character codes. Programming of these keys can be done from the keyboard when the terminal is in the Setup Mode and from the Host when the terminal is in the ANSI Mode. See the PPFN commands for further information.

When these keys are not specially programmed by the user, they are assigned default sequences as shown in the table on the next page.

Default Assignments for Function Keys - (Table 1.7)

<u>Key</u>	<u>Unshifted</u>	<u>Shifted</u>	<u>Control</u>
F0	<ESC>O	<ESC>O0	<ESC>O@
F1	<ESC>O!	<ESC>O1	<ESC>OA
F2	<ESC>O"	<ESC>O2	<ESC>OB
F3	<ESC>O#	<ESC>O3	<ESC>OC
F4	<ESC>O\$	<ESC>O4	<ESC>OD
F5	<ESC>O%	<ESC>O5	<ESC>OE
F6	<ESC>O&	<ESC>O6	<ESC>OF
F7	<ESC>O'	<ESC>O7	<ESC>OG
F8	<ESC>O(<ESC>O8	<ESC>OH
F9	<ESC>O)	<ESC>O9	<ESC>OI
F10	<ESC>O*	<ESC>O:	<ESC>OJ
F11	<ESC>O+	<ESC>O;	<ESC>OK
F12	<ESC>O,	<ESC>O<	<ESC>OL
F13	<ESC>O-	<ESC>O=	<ESC>OM
F14	<ESC>O.	<ESC>O>	<ESC>ON
F15	<ESC>O/	<ESC>O?	<ESC>OO
F16	<ESC>OP	<ESC>O`	<ESC>Op
F17	<ESC>OQ	<ESC>Oa	<ESC>Oq
F18	<ESC>OR	<ESC>Ob	<ESC>Or
F19	<ESC>OS	<ESC>Oc	<ESC>Os
F20	<ESC>OT	<ESC>Od	<ESC>Ot
F21	<ESC>OU	<ESC>Oe	<ESC>Ou
F22	<ESC>OV	<ESC>Of	<ESC>Ov
F23	<ESC>OW	<ESC>Og	<ESC>Ow

PF (Private Function) Keys

The PF keys generate private (machine specific) code sequences that may be assigned functions by the programmer. The codes generated by these keys are indicated below.

PF Key Codes - (Table 1.8)

<u>Key</u>	<u>Code</u>
PF1	<ESC>OP
PF2	<ESC>OQ
PF3	<ESC>OR
PF4	<ESC>OS

Numeric Keypad Keys

The numeric keypad consists of the block of keys below the PF keys. The keys on the numeric keypad normally transmit the ASCII codes for the numerals, decimal point, minus sign (hyphen) and comma (PKPN Mode). Thus they simply duplicate the functions of the corresponding keys in the main keypad. The ENTER key transmits the carriage return code. These keys are intended mainly as a convenience for users who must enter large amounts of numeric data.

The terminal may be commanded to assign special codes to these keys. See the PKPA (Keypad Application Mode) commands for further details.

Codes Generated by the Numeric Keypad Keys - (Table 1.9)

<u>Key</u>	<u>Code in PKPN Mode</u>	<u>Code in PKPA Mode</u>
0	0	<ESC>Op
1	1	<ESC>Oq
2	2	<ESC>Or
3	3	<ESC>Os
4	4	<ESC>Ot
5	5	<ESC>Ou
6	6	<ESC>Ov
7	7	<ESC>Ow
8	8	<ESC>Ox
9	9	<ESC>Oy
-	-	<ESC>Om*
,	,	<ESC>Ol
.	.	<ESC>On
ENTER	<CR>	<ESC>OM

Cursor Control Keys

The five keys grouped together at the right of the keyboard, including the Home key and the Arrow keys, are used primarily for the control of the display cursor. Cursor control with these keys requires that the codes generated when they are struck be echoed back to the terminal, either by the host or within the terminal itself (local echo).

Special Escape sequences can be assigned to these keys by means of the ANSI PCKM commands.

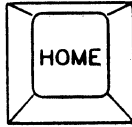

This key generates a control sequence that moves the cursor to the home position on the display. The home position is the upper left-hand corner of the display area.

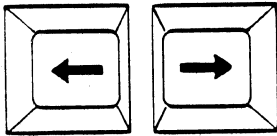
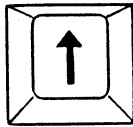

These keys generate codes that move the cursor in the direction of the arrows on the keys, one character cell per keystroke. When these keys are held down their codes are generated repeatedly.

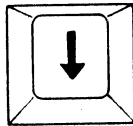

The code sequences generated by these keys are given in the table below.

Codes Generated by the Cursor Keys - (Table 1.10)

<u>Key</u>	<u>Code with PCKM set (special)</u>	<u>Code with PCKM reset (cursor control)</u>
Up Arrow	<ESC>OA	<ESC>[A
Down Arrow	<ESC>OB	<ESC>[B
Right Arrow	<ESC>OC	<ESC>[C
Left Arrow	<ESC>OD	<ESC>[D
Home	<ESC>OH	<ESC>[H

When the terminal is operated in the VT52 Mode these keys are automatically assigned VT52 cursor codes.

TERMINAL CONTROLS AND INDICATORS

The Power Switch and Line Fuse

The Power Switch for the Intecolor 2405 is in the back of the terminal on the left-hand side as you face the keyboard. The terminal should not be turned off and then back on immediately. A few seconds should be allowed between power-down and power-up to permit the terminal's power supplies to discharge. Otherwise the power supply control circuits will shut off power within the unit. In addition, reset might not occur.

A line fuse holder is installed on the rear panel next to the power switch. The fuse sometimes blows on account of a momentary surge on the line. It should always be replaced with another fuse of the proper rating. The rating depends on the line voltage as shown:

220V
Type 3AG
Slo-Blo
.75A/250V

115V
Type 3AG
Slo-Blo
1.5A/250V

If the fuse blows repeatedly, a properly qualified service technician should be called in to determine the problem.

Audible Indicators

The Intecolor 2405 produces two audible indicators: a click and a bell.

- Click The keyclick is an audible indication to the operator that a keystroke has been received by the terminal. The click can be disabled or enabled in the Setup Mode. The Shift, Control and Command keys do not produce clicks, and none of the keys produce clicks when the host has locked the keyboard.

- Bell The bell can sound for a variety of reasons. It can be sounded when the host transmits the ASCII bell code <BEL>, or when some particular condition exists in the terminal, when, for example the keyboard buffer is full. The bell also sounds on Power-up to indicate that reset has occurred.

PART TWO

PART TWO:
INSTALLATION, INTERCONNECTION AND POWER-UP

UNPACKING AND INSPECTING A NEW TERMINAL

The 2405 is shipped from the factory packed in a plastic foam, in a reinforced cardboard carton. When received, the carton should be inspected for damage **before** the unit is unpacked. If damage is discovered, the shipper and Intelligent Systems Corp. should be notified.

After unpacking and **before** installation and initial power-up, the terminal itself should be subjected to a careful visual inspection. It is a good idea to remove the cabinet cover and to verify that all cables within the unit are properly connected and that the circuit boards and CRT are secure. (The cover is held by two screws situated at sides of the cabinet.) Any damage should be reported to Intelligent Systems Corp.

While the cover is off, the setting of SW2, the line voltage selector switch mounted on the main circuit board, should be checked. This switch must be set for either 115V or 220V, in accordance with the line voltage at the site of installation.

WARNING: Work within the console should be performed only by persons who are aware of the possible hazards and are trained and qualified for this type of work.

Hazardous voltages may exist within the unit when power has been applied.

THE OPERATING ENVIRONMENT

When installing the 2405, it is important to take account of environmental factors at the site which could affect the terminal's performance.

The unit's **ambient temperature** should be maintained between 0° and 40° Centigrade. It is especially important that the specified maximum temperature not be exceeded, because the 2405 relies heavily on convection for heat dissipation while in operation. Temperatures below 0° C can cause damage to electrolytic capacitors in the unit.

Installation, Interconnection and Power-Up

The terminal should not be situated within strong **magnetic fields**, such as are present around large transformers. Magnetic fields can cause distortion of the display on the CRT screen.

Dust and smoke particles can cause problems since they are attracted by the unit's high voltage components and can collect at ventillating holes.

In especially **dry environments**, where electrostatic charges are easily created, it may be necessary for the operator to take precautions lest his handling of the equipment result in a discharge which could damage an integrated circuit. In such situations the operator can generally prevent damage by "grounding" himself before touching the keyboard.

The 2405's display is visible under normal indoor **lighting** conditions, and its brightness control compensates for some variation from such conditions. Accordingly, the area in which the 2405 is installed normally need not be darkened. However, the screen should be kept out of the glare of especially bright artificial light or sunlight.

IMPORTANT NOTE: Radio frequency emissions from the 2405 do not exceed the limits set by the FCC (in its Rules, Part 15, Subpart J) for class A computing devices. Nevertheless, the unit does radiate some radio frequency energy and accordingly can interfere with communications equipment (including but not limited to television receivers) and certain types of electronic instruments operating in the immediate vicinity. Precautions should be taken where appropriate.

The inside surfaces of the 2405's cabinet are coated with a conductive paint which serves as a shield for the equipment. The cabinet cover must be in place if RF emissions are to be minimized.

Installation, Interconnection and Power-Up

POWER-UP AND PRELIMINARY TESTING

WARNING: Before applying power to the terminal, verify that the line voltage selector switch, SW2, on the main circuit board is properly set and that the proper fuse is installed in the fuse holder on the rear panel. The fuse should be

1.5 Ampere 250V "Slo-Blo", type 3AG, for 115V operation, or

.75 Ampere 250V "Slo-Blo", type 3AG, for 220V operation.

For continued protection against fire and equipment damage, the fuse should be replaced only with a fuse of the proper type and rating.

WARNING: Operate the unit from a single-phase AC source only. The power supply protection circuit is not designed for two-phase sources. Do not defeat the purpose of the three-prong power plug (safety) by cutting or otherwise disabling the ground prong.

WARNING: The upper line voltage limit (248 VAC) must not be exceeded. The line filter, fuse, fuseholder and switch are rated at 250 VAC maximum.

After the terminal has been inspected it may be connected to an AC source, switched on and tested. Initial tests should be made with the host and any peripheral devices disconnected, but with the keyboard connected.

Note: The keyboard should always be connected before power is applied.

Before attaching the power cord, verify that the lower edge of the white power switch on the rear panel is depressed (the off position). Insert the power cord into its socket on the rear panel and then connect it to a source of single-phase AC power, 50 Hz or 60 Hz.

Turn the power switch to the on position (upper edge depressed).

Note: After applying power, it may be necessary to adjust the brightness control, a potentiometer mounted on the rear panel, to make the display visible.

The 2405 automatically goes through a self-test routine immediately after power is applied. If the self-test detects a problem, an error symbol consisting of a pattern of red dots followed by a character (@, A, C, G, or O) is displayed. (For information on the error codes see Part Three of this manual.) Otherwise, upon completion of the test routine the terminal displays the following multicolored header message at the top of the screen:

INTECOLOR 2400 V2.7 (C) Copyright 1983 by Intelligent Systems Corp.

Installation, Interconnection and Power-Up

This message gives the version of the software installed for the ANSI/VT52 command processor (V2.7). As this message is placed on display, the terminal is going through its initialization routines. Data stored in the terminal's permanent Setup memory registers read and used to set initial operating conditions, and tests are made for the presence of special equipment. For about a second the terminal is unable to communicate with a host or to accept keyboard input.

Note: It is possible for the terminal to power-up displaying a Setup Menu instead of the header message described above. The appearance of the Setup Menu at power-up indicates that no data are stored permanently in the Setup memory which would allow initialization to be completed.

In this case, certain Setup conditions must be established by the operator to make the terminal fully operational. Setup is fully discussed in Part Three of this manual. For purposes of initial testing, the following Setup selections should be made:

XON/XOFF	- YES
NEW LINE	- YES
PARITY	- NO
ECHO	- NO
LOCAL/LINE	- LINE
HOST RATE	- 9600

Then SAVE SETUP should be selected. (The settings of other Setup Menu items are not important at this time.)

After these Setup selections have been made, the terminal should be powered down and, after a few seconds, powered up again. The header message described above should appear.

If the terminal repeatedly goes into Setup Mode at power-up, the Setup memory's battery back-up is probably faulty and should be checked by a competent technician.

Assuming the header message appears as described, the terminal can be tested to insure that it is properly adjusted. A testing procedure is described on the following pages.

Initial Test

The terminal should be placed in an off-line condition to check for display alignment and proper character and color generation. This is done as follows:

- 1) While holding down a "Shift" key, strike the "Setup" key. A Set-Up Menu should appear.

Installation, Interconnection and Power-Up

- 2) Observe the setting of the Local/Line option as given in the menu. If necessary, depress the "J" key to select "Local".
- 3) Next, strike the "Set-up" key with the "Shift" key. The Setup Menu should disappear and the header message

INTECOLOR 2400 V2.7 (C) Copyright 1983 by Intelligent Systems Corp.

The following tests can now be performed:

- 1) Color generation and can be checked by creating rasters in each of the eight colors. This is done using the following sequence of keystrokes:

"Home", "Shift" together with "BG FG", "(one of the color keys, Q-I)", "Erase Page"

Each color should be pure and distinct.

A white raster is good for checking the straightness of the edges of the display. Edges with pronounced curves indicate a need for "pincushion" adjustment.

Note the size and position of the white raster. It should be 9.5 inches wide, 7.25 inches high and centered on the screen. Vertical and horizontal size and centering adjustments are indicated if these specifications are not met.

- 2) The character memory can be checked after selecting a background color (using the keystrokes described above) and a different foreground color, using the sequence of keystrokes

"Home", "BG FG" (unshifted), "(color key)".

The keyboard can then be used to put all the characters on the screen.

To check the special characters, strike the "N" key while holding down the "Control" key. Subsequently striking the unshifted alpha keys will then produce the special characters.

To shift back to the standard characters hold down the "Control" key and strike the "O" key.

Note: The control representation characters and the plotting blocks are not examined in this test.

Installation, Interconnection and Power-Up

- 3) The linearity of the display can be checked by filling the screen with L's or T's. This is done using the following sequence of keystrokes:

"Home", "Erase Page", "(L or T)", "ESC", "#", "8"

The vertical and horizontal components of the character should be aligned everywhere on the display.

If these preliminary tests indicate the need for adjustments, the Maintenance Manual for the Intecolor 2400 Series terminals should be consulted for adjustment procedures. Adjustments should be performed only by properly qualified service technicians.

Once the terminal is found to be operational and properly adjusted, it may be connected to the host and any peripheral equipment and placed in service.

Setup for on-line operation is described fully in Part Three.

INTERCONNECTION

Three connectors are provided at the rear panel of the 2427 for connection of the terminal to other equipment.

J4 is an 8 pin modular connector for the **keyboard**. Since the keyboard and its interconnecting cable are part of the 2405, the technician will not ordinarily be concerned with J4's pin assignments when he is installing the unit. However, they are given here for reference:

Keyboard Connector Pin Assignments - (Table 2.1)

- 1 - Ground (cable shield)
- 2 - Serial Data Input from keyboard (TTL levels)
- 3 - Clear-to-Send (active high) to keyboard

Note: This signal is high at all times when jumper W3 on the logic board is installed. For a Clear-to-Send signal under software control W3 must be removed and W4 installed. Normally, W3 is used. See the schematic diagram, drawing number 101959, sheet 2, for details.

- 4 - Ground
- 5 - +5 V to keyboard
- 6 - Ground
- 7 - +5 V to keyboard
- 8 - Ground

Installation, Interconnection and Power-Up

J6 is a 25 pin female connector used to connect the terminal to a **host** or other device, either directly or by way of a modem or current loop. Its pin assignments are:

Host Connector Pin Assignments - (Table 2.2)

- 1 - Ground
- 2 - Serial Data Output (RS-232 levels) to host
- 3 - Serial Data Input (RS-232 levels) from host
- 4 - Request-to-Send (active high) to host
- 5 - Clear-to-Send (active high) from host
- 6 - Data Set Ready (active high) from host
- 7 - Ground
- 8 - Data Carrier Detect (active high) from host
- 9 - NC
- 10- NC
- 11- Serial Data Input (current loop/+) from host
- 12- NC
- 13- NC
- 14- NC
- 15- External Clock Input

Note: Used for synchronous transmission to host. Requires jumper W13 on the logic board and the reprogramming of the USART.

- 16- NC
- 17- External Clock Input

Note: Used for synchronous reception of data from host. Requires installation of jumper W12 on the logic board and the reprogramming of the USART.

- 18- Serial Data Input (current loop/-) from host
- 19- NC
- 20- Data Terminal Ready (active high) to host
- 21- Serial Data Output (current loop/+) to host
- 22- NC
- 23- NC
- 24- External Transmit Clock Output
- 25- Serial Data Output (current loop/-) to host

J5 is a 25 pin female connector for a **printer**. Its pin assignments are:

Printer Connector Pin Assignments - (Table 2.3)

- 1 - Ground
- 2 - Serial Data Output to printer
- 5 - Clear-to-Send (active high) from printer
- 7 - Ground
- 20- Data-Terminal-Ready (high) to printer

Installation, Interconnection and Power-Up

Note: The terminal only transmits and does not receive data at the printer connector. Only the pins listed are used.

Another connector, **J2**, an 6 pin header on the logic board between J3 and J5, is used for a **light pen**. The pin assignments are:

Light Pen Connector Pin Assignments - (Table 2.4)

- 1 - Ground
- 2 - +5V to light pen
- 3 - "Switch" input from light pen

Note: The 2405 is set up for light pens with normally closed touch switches.

- 4 - "Light detect" input from light pen
- 5 - Ground
- 6 - +5V to light pen

PART THREE

**PART THREE: SETUP, TESTING AND ON-LINE
OPERATION**

SETTING UP THE TERMINAL

The Intecolor 2405 has a Setup Mode of operation which allows the operator to set the terminal's operating conditions (baud rates, display format, etc.) from the keyboard while referring to a plain language menu. This feature eliminates the need for switches which are present on some terminals. Several settings must be made before the terminal can be operated on-line. Others are optional.

The terminal has two memory register sets dedicated to Setup data. One register set is operative at all times, even when the terminal is disconnected from the power line. The other is operative only when AC power is applied to the terminal. When the terminal is placed in operation, the contents of the first register set are automatically loaded into the second (temporary) set and the terminal is set up according to the contents of the second set. The data in this register set can be read and changed by the operator when he places the terminal in the Setup Mode.

NOTE: Changing the data in the temporary Setup registers results in a new setup for the current operating session. However, it can have no effect on the way the terminal will come up in subsequent operating sessions unless a Store Setup command is issued while the terminal is in the Setup Mode. (See below.) When the terminal receives this command it adjusts the contents of the first (permanent) register set to agree with the contents of the temporary register set.

If the permanent Setup registers are empty at power-up, the terminal automatically enters the Setup Mode. This happens very rarely, usually because the memory's battery has failed. (The battery has a life expectancy of about five years.)

The terminal enters or exits the Setup Mode when the Setup key is operated while a Shift key is held down. This Mode may be entered from any other mode of operation except the Self-Test Mode. If Setup Mode is entered when the terminal is on-line and receiving data from a host, the host is automatically signaled to stop sending until the operator returns the terminal to on-line operation. If a standard resolution display is present when Setup Mode is entered, this display disappears until the terminal leaves Setup Mode, at which time the original display returns.

Setup, Testing and On-Line Operation

(The second page of the display memory is used in Setup Mode.) If a high resolution display is present, this display remains visible while the terminal is in Setup Mode.

When the Setup Mode is entered a series of menus is displayed on the terminal screen, showing the terminal's current communications settings and other current conditions. An example of the main Setup Menu is given below.

SETUP FUNCTION - To exit SETUP MODE, press SHIFT + SETUP key

A)	XON/XOFF	YES
B)	MARGIN BELL	NO
C)	KEYCLICK	NO
D)	WRAP	NO
E)	NEW LINE	YES
F)	SCREEN SAVER	NO
G)	PARITY	OFF
H)	CURSOR TYPE	-
I)	ECHO	NO
J)	LOCAL/LINE	LINE
K)	HOST RATE	19200
L)	PRINTER RATE	300
M)	COLOR PRINTER	NO
N)	ANSI 3.64	YES
O)	TABS	
P)	ANSWERBACK	
Q)	FUNCTION KEYS	
R)	STORE SETUP	

INTECOLOR 2400 V2.7 (C) Copyright 1983 by Intelligent Systems Corp.

(Figure 3.1)

Setup, Testing and On-Line Operation

Down the left-hand side of the menu are letters which indicate the keys to be used to change settings or to call up other menus. The middle column contains the names of the functions, parameters, etc. which are in question. The right-hand column shows the current settings.

Most of the items on the menu have only two possible settings. The keys associated with these items are used to toggle between settings. When an item (Host Rate, for example) has more than two possible settings, striking its associated key results in the display of a new menu showing a set of possible settings and the keys to be used to select them.

There is no provision in Setup Mode for adjusting the terminal's display generators to the power line frequency (50Hz for most 220V single phase power lines throughout the world, 60Hz for 115V single phase lines in the United States) because this is done automatically by the logic circuitry.

Also, there is no provision for setting the number of stop bits used in host/terminal communications. The number of stop bits is fixed at 1.

Items on the Main Setup Menu

XON/XOFF

Menu key: A
Settings: YES, NO

The 2405 is capable of automatically sending XON and XOFF codes to the host computer and responding to these codes when received from the host (software handshaking). It only uses this capability when the XON/XOFF option is enabled. When this option is enabled the terminal sends an XOFF when any of the following occur:

- 1) The terminal is placed in Setup Mode.
- 2) (Control S) is entered at the keyboard.
- 3) The receiving buffer becomes half-full.

An XON is sent only after an XOFF has been sent and (Control Q) is entered at the keyboard or the receiving buffer drops below one-fourth full.

Setup, Testing and On-Line Operation

MARGIN BELL

Menu key: **B**
Settings: YES, NO

When the Margin Bell is enabled the 2405 sounds a bell when the cursor is eight characters from the end of the current line. This feature is much like the margin bell on a typewriter.

KEYCLICK

Menu key: **C**
Settings: YES, NO

The keyclick is a sound generated by the terminal every time a key other than CONTROL or SHIFT is pressed. Most typists find the keyclick helpful for more accurate typing. If the host computer locks the keyboard, the keys will not generate a click.

WRAP

Menu key: **D**
Settings: YES, NO

This option, when enabled, causes the cursor to be automatically repositioned at the beginning of the next text line when a given line has been filled. If the option is not enabled, the cursor must be repositioned with commands inserted into the text stream; otherwise, characters are placed at successive positions as received until the end of a line is reached, at which point subsequent characters are all placed in the last character cell of that line.

NEW LINE

Menu key: **E**
Settings: YES, NO

This option, when enabled, causes line feed codes received to be treated as carriage return and line feed codes.

Setup, Testing and On-Line Operation

SCREEN SAVER

Menu Key: **F**
Settings: YES, NO

When the F key is struck the current setting for the Screen Saver is changed. "Yes" indicates that the Screen Saver is enabled, "No" that it is disabled.

PARITY

Menu key: **G**
Settings: OFF, EVEN, ODD

When the G key is struck, a Parity Menu appears on the screen. The menu has three items, as shown:

- A) OFF
- B) EVEN
- C) ODD

A selection is made by striking the key whose letter is associated with the desired parity setting. If the operator does not wish to change the current selection, he uses the Shift-Setup key combination to return to the Main Menu. When a new selection has been made, the main Setup Menu reappears on the screen, and the selection appears beside Main Menu item G.

When parity is enabled, the terminal tests for errors in received data stream according to the function selected; it also modifies data to be transmitted to the host to permit parity checking by the host. When an error is detected by the terminal, it displays an error character in place of the character which was improperly received.

Parity checking requires the use of the high order bit in each data byte sent or received. Accordingly, when parity is enabled there are seven data bits per data word and the seven-bit ASCII code can be used. However, special eight-bit codes cannot be used unless parity checking is disabled to make the eight bit in each word available for data.

CURSOR TYPE

Menu key: **H**
Settings: BLK , , BLOCK, BLK BLOCK, NONE

When the H key is struck a Cursor submenu appears. The menu contains five items, as follows:

Setup, Testing and On-Line Operation

- A) BLK _ (Blinking Underscore)
- B) _ (Underscore)
- C) BLOCK (The block cursor occupies one entire character cell.)
- D) BLK BLOCK (Blinking block)
- E) NONE

A selection is made by striking the key whose letter is associated with the desired cursor type. After a selection is made, the main menu reappears showing the cursor type selected.

ECHO

Menu key: I
Settings: YES, NO

This option allows the operator to determine whether or not the keyboard input being routed to the host will also be routed directly to the display. Local echo is selected by setting item I to "YES". Since many host computers echo everything they receive, they make the use of local echo unnecessary and superfluous (characters echoed by terminal and host would be displayed twice). Accordingly, the option can be disabled by selecting "NO".

Note that the use of the keyboard for display control usually requires that some type of echo be enabled.

LOCAL/LINE

Menu key: J
Settings: LOCAL, LINE

This option allows the operator to place the terminal ON-LINE or in LOCAL mode. When the terminal is on-line, it is able to communicate with the host computer. Anything typed into the keyboard goes to the host computer, but when the terminal is in LOCAL mode, no communications can take place between the terminal and the host computer. Any characters typed at the keyboard are echoed to the display screen and are not sent to the host computer.

HOST RATE

Menu key: **K**
Settings: (see Table 3.2)

When the K key is pressed, a menu of baud rate options is displayed. To select a new baud rate, press the key beside the rate to be used. Table 3.1 shows the various communication rates that the 2405 can use and their corresponding selection keys.

Baud Rates - (Table 3.2)

A) 50	I) 1050
B) 75	J) 1200
C) 110	K) 1800
D) 134.5	L) 2000
E) 150	M) 2400
F) 200	N) 4800
G) 300	O) 9600
H) 600	P) 19200

PRINTER RATE

Menu key: **L**
Settings: (see Table 3.2)

This item is much like the host rate except that it selects the communication rate for an auxiliary device connected at the terminal's serial output port (printer).

COLOR PRINTER

Menu key: **M**
Settings: YES, NO

This option allows the user to signal the terminal that the auxiliary device connected at the printer port can accept and process standard ANSI command sequences for color changes and format control. If this option is enabled, the terminal passes these command sequences on to the auxiliary device. If the option is disabled, these sequences are suppressed. (See FETM commands.)

ANSI 3.64

Menu key: **N**
Settings: YES, NO

This option allows the user to specify that the terminal respond to standard ANSI command sequences or to an alternate set of command sequences when operating in Transparent Mode. If this option is enabled, the terminal responds to ANSI and private command sequences. If this option is disabled, the terminal responds to VT52 type command sequences (See PATM commands.)

TABS

Menu key: **O**
Settings: (See Figure Below)

This option permits setting the horizontal tabulation stops to be used with ANSI tab commands and with the <HT> terminal control code. (See CHT and CBT commands.)

In ANSI Mode, the 2405 has two horizontal tab modes, line-tab mode and page-tab mode. In line-tab mode, each line has tabulation stops in the same columns. In page-tab mode, the horizontal tabulation stops are set on specific line and column positions, which means that one line might have three tabulation stops while the next line might have five tabulation stops at different positions from the previous line. Page-tab mode tabulation stops can only be set by special ANSI control sequences. (See TSM and CTC commands.)

When the M key is pressed, the terminal is placed in line-tab mode, and default horizontal tab stops are set at intervals of eight columns. A ruler is displayed showing the tab stops that are set (see Figure 3.2). A tabulation stop is denoted by the letter T under the column on the ruler where the tabulation stop is set. The cursor is placed on the ruler. The Space bar, the Tab key, the Return key, and the left and right Arrow keys can be used to move the cursor over the ruler. To clear a tabulation stop, move the cursor to the tabulation stop to be cleared and then strike the C key. To set a tabulation stop, move the cursor to the column that at which the tabulation stop is to be set and then strike the T key. The tab indicators will reflect any changes made to the tabulation stops.

(Figure 3.3)

.....+.....1.....+.....2.....+.....3.....+.....4.....+.....5.....+.....6.....+.....7.....+.....8
T T T T T T T T T

Pressing the SETUP key while holding the Shift key down stores the new tab settings and restores the main Setup menu.

Setup, Testing and On-Line Operation

ANSWERBACK MESSAGE

Menu Key: P

Settings: Answerback response message defined by operator

This option permits the definition of an identifying message of up to twenty characters to be transmitted by the terminal to the host computer when the host issues an enquiry <ENQ>. This response to a host computer inquiry will take place without the knowledge of the operator and without altering the data on the screen.

To review or define the terminal's answerback message, press the N key. The current answerback message is displayed on the screen. If no changes are desired, the main Setup menu can be restored by striking the Setup key while holding a Shift key down. To define the answerback message strike the F0 key. The terminal is then ready to accept up to twenty characters, entered at the keyboard, as the answerback message. To terminate the new answerback message, press the F1 key. The terminal then stores the new answerback message and restores the main Setup menu.

Note: The answerback message can contain the characters generated by any key except the function keys themselves and the SETUP key.

Note: To correct an error made while defining the answerback message, hold down the Command key while striking the Back Space key.

FUNCTION KEYS

Menu Keys: Q

Settings: Function key definitions

The function keys are keys that can be programmed to generate sequences of up to 40 characters when struck. Each function key can generate three different sequences, one for the unshifted key, one for the Shifted key, and one for when the key is used with the Control key.

To review or define a character sequence for a function key, first press the P key while the terminal is in Setup Mode. Next, press the key (by itself or with the Shift or Control key) whose sequence is to be reviewed or changed. The terminal then displays the characters assigned to that function key and prompts the operator to indicate that the assignment is to be changed or is to remain in effect. The operator responds by pressing any key except the Y key if he wants to make no changes. The terminal then restores the main Setup menu. He responds by pressing the Y key if he wishes to make a new assignment. The terminal then accepts up to 40 characters entered at the keyboard as the new assignment. When the assignment is complete, the key being defined is pressed. The terminal then stores the new assignment in memory and restores the main Setup menu.

Setup, Testing and On-Line Operation

Note: The function key assignment can contain the characters generated by any keys except the function keys themselves and the SETUP key.

Note: To correct an error made while defining a function key assignment, hold down the Command key while striking the Back Space key.

Note: Function Key assignments are not retained from operating session to operating session unless a Save Setup command is issued following their definitions. (See below.)

Note: If the function keys are not defined by the user, or if user definitions are not stored in the permanent Setup Memory, their assignments revert to the default values shown in the introduction.

STORE SETUP

Menu Key: R

This option allows you to store the current set up configuration in permanent memory. When this option is selected the current set up features become those which will be enabled subsequently at power-up or in response to an ANSI RIS command.

Summary of Terminal Setup Options

<u>Setup Menu Item</u>	<u>Settable by Host In ANSI Mode</u>	<u>Normal or Default Setting</u>
XON/XOFF	no	YES
Margin Bell	no	optional
Wrap	PAWM	optional
New Line	LMN	YES
CRT Saver	no	optional
Parity	no	NO
Cursor Type	no	optional
Keyclick	no	optional
Echo	SRM	NO
Line/Local	no	LINE
Host Rate	no	9600
Printer Rate	no	optional
Color Printer	FETM	optional
ANSI 3.64	PATM	YES
Tabs	CTC, TSM	optional
Answerback	no	optional
Function Keys	PPFN	optional
Store Setup	no	(defaults stored)

HOST-TERMINAL COMMUNICATIONS

Software Handshaking

The 2405 processes the incoming data from the host computer through a first in/first out 255 character buffer. If the rate of arriving characters exceeds the rate at which the terminal can process characters, this buffer will begin to fill up. To avoid having the buffer overflow, the terminal has a XON/XOFF signaling capability. If the Auto XON/XOFF feature is enabled, the terminal transmits an XOFF code (<DC3> or 13 hex) to the host computer when the character count of the buffer exceeds 152 characters. In response, the host computer should cease transmitting data until the terminal sends an XON code (<DC1> or 11 Hex). If the host does not follow this convention, the buffer may continue to fill and overflow, which could result in the loss of data. The 2405 processes the characters in the buffer until the character count drops below 76, at which time the terminal transmits the XON code. The use of the XON and XOFF codes ensures that all data are processed by the terminal correctly.

The XON and XOFF codes can also be transmitted from the keyboard. To transmit an XOFF code, press (Control S). To transmit an XON code, press (Control Q). These keys will send the same codes as the convention described above.

Setup, Testing and On-Line Operation

The terminal will transmit the XOFF code if any characters are received from the host while the terminal is in the Self-test or Setup Mode. The terminal will send an XON code when it exits either of these modes and is able to process received characters.

The 2405 also recognizes the XON/XOFF conventions when they are sent by the host computer. If the host computer sends an XOFF command, the terminal will cease sending characters to the host computer. Any keys typed at the keyboard will be stored in the keyboard buffer until it becomes full or until the host computer sends an XON command. If the keyboard buffer becomes full and another key is pressed, the bell will sound.

The 2405 can be used with a host computer which does not support the XON/XOFF conventions. The main requirement is that the baud rate be limited to 4800. It may be desirable to disable XON/OFF signaling when a host application program uses one of these control codes in a special way.

Terminal Control Codes

Several of ASCII control codes (represented by the values between 00 and 1F Hex and the value 7F Hex) are used either by themselves or as command sequence introducers for overall terminal control. These control codes form a group which is distinct from the command sets proper to the terminal's various modes of on-line operation.

When received, these codes cause the terminal to perform some function other than the production of a display element.

These codes can be sent from the keyboard if some type of echo is enabled.

Terminal Control Codes and Their Actions

(Table 3.4)

<u>Code</u>	<u>Selectable Recognition</u>	<u>Function</u>
<BEL>		Causes terminal's audible indicator to sound
<BS>		Causes cursor to move one space to the left
<CAN>		Cancels multi-character control sequence
<CR>		Causes the cursor to move to the left margin of the current line. If item D "New Line" is selected in Setup Mode, <CR> is interpreted as <CR><LF>.
<DC1>	Yes	Causes the terminal to resume sending to the host (same as XON)
<DC3>	Yes	Causes the terminal to stop sending to the host (same as XOFF)
<ENQ>	Yes	Causes the terminal to send its answerback message to the host.
<FF>		Same as <CR>
<HT>		Causes cursor to move one tab stop to the right
<LF>		Causes the cursor to move down one line
<SI>		Causes the terminal's alternate character set to be used for text display. (See SCS commands.)
<SO>		Causes the terminal to revert to its normal character set for text display.
<VT>		Causes the cursor to move up one line

Setup, Testing and On-Line Operation

THE TERMINAL'S SELF-TEST CAPABILITIES

The test routines which are automatically invoked at terminal power-up can also be invoked with an ANSI command sequence while the terminal is in ANSI Mode. These tests check the operation of the terminal microprocessor's program memory, the I/O devices, the Setup memory, and the display memory.

The tests can discover bad memory data and other faults provided the terminal's power supplies, CRT deflection circuits and standard resolution display generator are functioning.

These tests are invoked with the following command sequence (PCFN):

<ESC> [Pn y

"Pn" stands for a decimal integer which can have the following values:

<u>Pn</u>	<u>Test Selected</u>
0 or 1	ANSI/VT52 processor program memory Setup Memory Standard Resolution Display memory ANSI/VT52 and graphics processor I/O
2	ANSI/VT52 and graphics processor I/O
4	Keyboard/printer I/O

Pn can also be the sum of any of these values, in which case a combination of tests is selected. For example, if it is desired to test both I/O devices, but not the memories, Pn should be 6. When Pn has values from 0 to 7 one test cycle will be performed. If 128 is added to the value of Pn the selected test or tests is repeated until one of three things happens: 1) the Setup key is struck to abort testing, 2) the terminal is powered down, 3) a fault is discovered. If Pn is 255, all tests are repeated in a like manner.

The fact that a test is underway is not indicated by the display unit unless the display memory itself is under test or unless a fault is discovered. If a fault is discovered, a coded message is displayed, as indicated on the chart following.

Setup, Testing and On-Line Operation

Self-Test Error Codes

(Table 3.4)

<u>Code</u>	<u>Fault</u>
@	System program memory (UA6 and UA7, main logic board)
A	Setup memory (UA8, main logic board)
C	Display memory (UB4, UB5, UB6 and UB7, main logic board)
G	ANSI/VT52 and graphics processor I/O (UD1, main logic board)
O	Keyboard/printer I/O (UD2, main logic board)

Depending upon how the self-test is invoked and depending upon the results of the test, one of four possible events will occur.

If the test is invoked for one cycle and there are no problems, the test will conclude and the terminal will become active and ready for use.

If there are no hardware problems, but the self-test finds invalid data in the nonvolatile Setup Memory, the terminal will automatically enter Setup Mode and the default settings for all Setup options will be made automatically. In this case the operator should make any changes required in the setup and select the Store Setup option to save settings in the nonvolatile memory. He may then use the Shift and Setup keys to place the terminal on line.

Note: If the terminal repeatedly enters Setup Mode at power-up, even after a Store Setup command has been given, the Setup memory's battery backup should be checked by a properly qualified technician. For further information, see the 2400 Series Maintenance Manuals.

PART FOUR

PART FOUR: OPERATION IN THE ANSI X3.64 MODE

ANSI CONTROL SEQUENCES

When operating in the ANSI Mode, the 2405 responds to control sequences formed according to the ANSI (American National Standards Institute) X3.64 standard. ANSI X3.64 operation is selected by the operator when the terminal is in the Setup Mode. (See Part Three for details.) ANSI sequences are described in this section of the manual. The VT52 commands are described in a subsequent section.

The ANSI standard allows commands to include arguments of varying lengths. The arguments are interpreted according to final character in the command sequence. This command format is very flexible. On the one hand, it permits the command set to be expanded without extensive rewriting of terminal software. On the other hand, it permits the sending of commands to a terminal which is not equipped to execute them. Such commands are merely ignored by the terminal.

Command Structure

The structure of an ANSI command is as follows: The command begins with a Control Sequence Introducer. The introducer is followed by a variable number of numeric arguments (parameter values), set off by semicolons. These values are followed by a final character which indicates the operation to be performed.

- The control sequence introducer (CSI) is an ASCII Escape code followed by a left bracket: <ESC>[
- A numeric parameter value is always in the range 0-255 decimal and is given as a string of ASCII numeric characters. Numeric parameters include such things as x and y coordinates.
- A selective parameter value is a special type of numeric value. Selective parameters distinguish subfunctions within the general functions indicated by the command's final control character.
- Parameter values in a sequence are separated by semicolon delimiters only. No delimiter is given between the control sequence introducer and the first parameter value. No delimiter is given between the last parameter value and the final control

character.

- The control character is an ASCII upper case or lower case alphabetic character or punctuation mark other than the semicolon. Such a character always terminates the command sequence when received following the CSI. The control character indicates a major terminal function, in terms of which the preceding parameter values are interpreted. The number of parameters evaluated in a command sequence depends on this character.

Note: An ASCII control code may be embedded in an ANSI command sequence. If the terminal receives a control code following the reception of the CSI and before the reception of the ANSI control character, the control code is treated as not belonging to the sequence and is acted upon as usual; the ANSI sequence is acted upon subsequently and when it has been completely received.

Examples of Valid ANSI Command Sequences

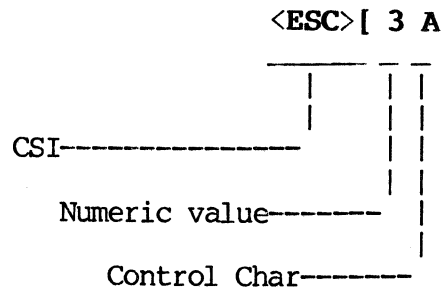

This command would cause the terminal to move the cursor up 3 lines. The "3" is interpreted as a number of lines in relation to the "A", which indicates cursor movement upwards.

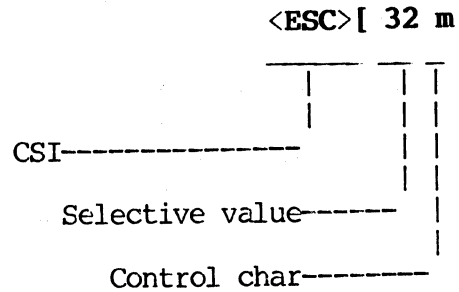

This command would cause the terminal to display subsequently received text with the foreground color green. Note that "32" indicates foreground display in green only in relation to "m". Foreground display in green is treated here as a subfunction of a general function called "select graphic rendition".

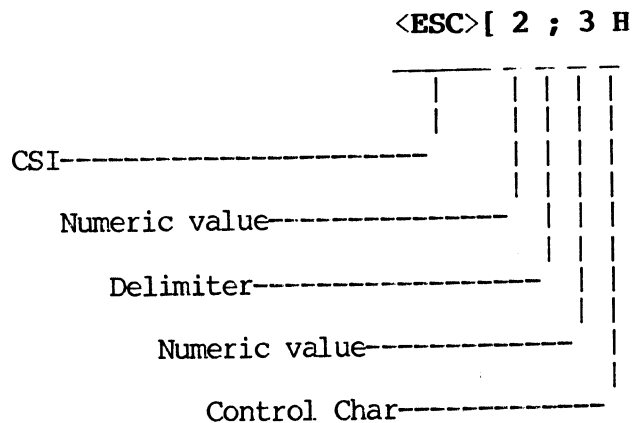

This command would cause the terminal's cursor to move to line 2, column 3. Note that the final character "H" indicates cursor movement in terms of lines and columns; accordingly, it determines the number of numeric values which are included.

A Note on Erroneous Commands

Whenever the terminal receives the control sequence introducer `<ESC>[` it treats every subsequently received byte of code other than an ASCII control code as an element of a command. The first alphabetic or punctuation code received following the introducer other than the semicolon code is always treated as the command terminator. A terminated command is

either ignored completely (if the terminator does not indicate a function implemented in software) or executed as sent.

If a command sequence does not specify values for all applicable parameters, the terminal supplies default values for those missing from the command. If the command includes too many values, the extra values are ignored. If a semicolon delimiter is omitted, the two numbers which should have been delimited are treated as a single number. If this number is greater than 255, it is treated as 255.

ANSI X3.64 COMMAND SEQUENCE LISTING

The commands are listed alphabetically by mnemonic and described in detail. Summaries of the command sequences, listed by mnemonic, by function, and by code, are given in the appendices.

CBT Cursor Backward Tabulation- HOST to Terminal and Terminal to HOST

<ESC> [Pn Z default value: 1

The Cursor Backward Tabulation (CBT) command sequence moves the current cursor position horizontally in a backward direction to the previous tabulation stops. No parameter value, a parameter value of zero or a parameter value of one moves the current cursor position to the first previous tabulation stop. A parameter value of larger than one moves the current cursor position backward that many tabulation stops.

CHT Cursor Horizontal Tabulation- HOST to Terminal and Terminal to HOST

<ESC> [Pn I default value: 1

The Cursor Horizontal Tabulation (CHT) command sequence moves the current cursor position horizontally in a forward direction to the next tabulation stops. No parameter value, a parameter value of zero or a parameter value of one moves the active position to the next tabulation stop. A parameter value of larger than of one moves the current cursor position forward that many tabulation stops.

CPR Cursor Position Report- Terminal to HOST

<ESC> [Pn ; Pn R

The Cursor Position Report (CPR) sequence reports the current cursor position to the host computer. The sequence has two parameters, the first specifying the current line number and the second specifying the current column. Both lines and columns are numbered from zero with home position denoted by both parameters being zero.

This control sequence is sent in response to a device status report sent from the host (see DSR, this section).

CRM Control Representation Mode- HOST to Terminal

<ESC> [3 h - to set Mode (SM)

<ESC> [3 l* - to reset Mode (RM)

The Control Representation Mode (CRM) is a parameter that is controlled by the Set Mode (SM) and Reset Mode (RM) ANSI sequences. The reset state causes terminal control commands to be executed and to have no graphic representation in the display. The set state keeps controls from being executed, but instead displays a graphic code for each character received.

*Note: The final character in this sequence is a lower case L.

CTC Cursor Tabulation Control- HOST to Terminal

<ESC> [Pn W

default value: 0

The Cursor Tabulation Control (CTC) command sequence clears or sets one or more tabulation stops according to the parameter(s). When horizontal tabulation stops are set or cleared, the effect may be only on the active line or it may be on all lines depending upon the state of the Tabulation Stop Mode (TSM). (Refer also to TBC)

<u>Pn</u>	<u>Action</u>
0	Sets a horizontal tabulation stop at the current cursor position (default)
1	Sets a vertical tabulation stop at the current line
2	Clears the horizontal tabulation stop at the current cursor position
3	Clears the vertical tabulation stop at the current line
4	Clears all horizontal tabulation stops in the current line
5	Clears all horizontal tabulation stops
6	Clears all vertical tabulation stops

CUB Cursor Backward- HOST to Terminal and Terminal to HOST

<ESC> [Pn D default value: 1

The Cursor Backward (CUB) command sequence moves the current cursor position to the left. The parameter determines the number of positions to be moved. If the parameter is one or zero, the command moves the current cursor position one position to the left. If the parameter value is greater than one, the command moves the current cursor position a distance equal to the parameter. Once the current position reaches the left margin, it moves no further.

CUD Cursor Downward- HOST to Terminal and Terminal to HOST

<ESC> [Pn B default value: 1

The Cursor Downward (CUD) command sequence moves the current cursor position downward while maintaining the same column position. The parameter determines the number of positions to be moved. If the parameter is one or zero, the command moves the current cursor position one line downward. If the parameter value is greater than one, the command moves the current cursor position a distance equal to the parameter. Once the current position reaches the bottom margin, it moves no further.

CUF Cursor Forward- HOST to Terminal and Terminal to HOST

<ESC> [Pn C default value: 1

The Cursor Forward (CUF) command sequence moves the current cursor position to the right. The parameter determines the number of positions to be moved. If the parameter is one or zero, the command moves the current cursor position one position to the right. If the parameter value is greater than one, the command moves the current cursor position a distance equal to the parameter. Once the current position reaches the right margin, it moves no further.

CUP Cursor Position- HOST to Terminal and Terminal to HOST

<ESC> [Pn ; Pn H default value: 1

The Cursor Position (CUP) command sequence moves the current cursor position to the position specified by the parameters. The two parameters determine the new position, with the first parameter specifying the line position and the second parameter specifying the column position. If either parameter is one or zero, the command moves the current cursor position to the first line or column respectively. The default position with no parameters is equivalent to a Home Cursor action.

This command is sent by the terminal with the appropriate parameters when the light pen is detected.

CUU Cursor Up- HOST to Terminal and Terminal to HOST

<ESC> [Pn A default value: 1

The Cursor Up (CUU) command sequence moves the current cursor position upward while maintaining the same column position. The parameter determines the number of positions to be moved. If the parameter is one or zero, the command moves the current cursor position one line upward. If the parameter value is greater than one, the command moves the current cursor position a distance equal to the parameter. Once the current position reaches the top margin, it will move no further.

CVT Cursor Vertical Tabulation- HOST to Terminal and Terminal to HOST

<ESC> [Pn Y default value: 1

The Cursor Vertical Tabulation (CVT) command sequence moves the current cursor position downward to the next or following in a series of vertical tabulation stops without altering the horizontal position. No parameter value, a parameter value of zero or a parameter value of one moves the active position to the next line with a vertical tabulation stop. A parameter value of larger than of one moves the active position forward that many tabulation stops.

ED Erase In Display- HOST to Terminal

<ESC> [Pn J

default value: 0

The Erase In Display (ED) sequence erases some or all of the characters in the display according to the value of the parameter.

<u>Pn</u>	<u>Action</u>
0	Erases from the active position to the end of the display screen, inclusive
1	Erases from the start of the display screen to the active position, inclusive
2	Erases all of the display screen

EL Erase In Line- HOST to Terminal

<ESC> [Pn K

default value: 0

The Erase In Line (EL) sequence erases some or all of the characters in the current line according to the value of the parameter.

<u>Pn</u>	<u>Action</u>
0	Erases from the active position to the end of the current line, inclusive
1	Erases from the start of the current line to the active position, inclusive
2	Erases all of the current line

FETM Format Effector Transfer Mode- HOST to Terminal

<ESC> [14 h - to Set Mode (SM)

<ESC> [14 l* - to Reset Mode (RM)

The Format Effector Transfer Mode (FETM) is a parameter that is controlled by the Set Mode (SM) and Reset Mode (RM) ANSI sequences. This parameter is the same parameter that is controlled by the Color Printer option in the SET-UP mode. The reset state allows the terminal to pass command sequences on to the auxiliary device. The set state causes the terminal to suppress sending command sequences on to the auxiliary device. (See Color Printer option in SET-UP Mode in Chapter 1.)

*Note: The last character in the sequence is a lower case L.

HTS Horizontal Tabulation Set- HOST to Terminal and Terminal to HOST

<ESC> H

The Horizontal Tabulation Set (HTS) command sequence sets one horizontal tabulation stop at the active position. This command sets the tabulation stop on the active line only or on all lines depending upon the state of the Tabulation Stop Mode (TSM).

HVP Horizontal & Vertical Position- HOST to Terminal and Terminal to HOST

<ESC> [Pn ; Pn f default value: 1

The Horizontal & Vertical Position (HVP) command sequence moves the current cursor position to the position specified by the parameters. The two parameters determine the new position, with the first parameter specifying the line position and the second parameter specifying the column position. If either parameter is one or zero, the command moves the current cursor position to the first line or column respectively. The default position with no parameters is equivalent to a Home Cursor action.

IND Index- HOST to Terminal and Terminal to HOST

<ESC> D

The Index (IND) command sequence moves the active position down one line without changing the horizontal position. If the active position is at the bottom margin, a Scroll Up (SU) is performed.

KAM Keyboard Action Mode- HOST to Terminal

<ESC> [2 h - to Set Mode (SM)

<ESC> [2 l* - to Reset Mode (RM)

The Keyboard Action Mode (KAM) is a parameter that is controlled by the Set Mode (SM) and Reset Mode (RM) ANSI sequences. The reset state enables the keyboard. The set state disables the keyboard. When the keyboard is disabled, the keyclick will not sound.

*Note: The last character in the sequence is a lower case L.

LNМ Line Feed New Line Mode- HOST to Terminal

<ESC> [20 h - to Set Mode (SM)

<ESC> [20 l* - to Reset Mode (RM)

The Line Feed New Line Mode (LNМ) is a parameter that is controlled by the Set Mode (SM) and Reset Mode (RM) ANSI sequences. The reset state causes the interpretation of the Line Feed (LF) to imply only vertical movement of the active position. The set state causes the Line Feed to imply movement to the first position of the following. This is the New Line option. This mode does not affect the Vertical Tabulation (VT), Form Feed (FF), Index (IND), or Next Line (NEL).

*Note: The last character in the sequence is a lower case L.

MC Media Copy- HOST to Terminal

<ESC> [Pn i

default value: 0

The Media Copy (MC) command sequence initiates and controls the transfer of data from the terminal to the auxiliary device according to the value of the parameter.

<u>Pn</u>	<u>Action</u>
0	Copies the entire contents of the display screen to the auxiliary device
4	Turns off copying of received data to the auxiliary device (Terminates Media Copy)
5	Turns on copying of received data to the auxiliary device and turns off copying of received data to display screen
6	Turns off copying of received data to the auxiliary device (Terminates Media Copy)
7	Turns on copying of received data to the auxiliary device but data continues to be copied to display screen

During Media Copy (MC), if XON/XOFF is enabled the Intecolor 2400 sends XOFF and XON codes to synchronize the character rate from the host computer with the character rate of the auxiliary device.

NEL Next Line- HOST to Terminal and Terminal to HOST

<ESC> E

The Next Line (NL) command sequence moves the current cursor position to the first position on the next line downward.

NP Next Page- HOST to Terminal

<ESC> [U

The Next Page (NP) command sequence displays the second page of the display memory on the terminal screen. The cursor position, the current foreground and background colors and the vertical margins for the first page are saved in memory, and these same parameters for the second page become active. These parameters for the second page are saved when a Previous Page (PP) command is received.

PALN (Private) Screen Alignment Display- HOST to Terminal

<ESC> # 8

The Screen Alignment Display (PALN) command sequence causes the display page to be filled with the character which precedes the cursor at the time the command is issued. If the cursor is in the HOME position, a white page is displayed. This command is used for maintenance and screen alignment.

PATM (Private) ANSI Terminal Mode - HOST to Terminal

<ESC> [? 2 h - to Set Mode (PSM)

<ESC> [? 2 l* - to Reset Mode (PRM)

The ANSI Terminal Mode (PATM) allows the host computer to specify whether the terminal will process the standard ANSI commands specified in this section of the manual or the alternate VT52 type commands specified in the following section. The set state specifies ANSI commands.

PAWM (Private) Auto Wrap Mode- HOST to Terminal

<ESC> [? 7 h - to Set Mode (PSM)

<ESC> [? 7 l* - to Reset Mode (PRM)

The Auto Wrap Mode (PAWM) allows the host computer to set or reset the Wrap Mode. This is the same feature that is set in the SET-UP mode. (see WRAP in SET-UP) In the set mode, the 81st and following characters of a line will be displayed on the following line. In the reset mode, the 81st and following characters of a line will be overlaid onto the 80th position of the current line.

PCDP (Private) Cursor Display Mode - Host to Terminal

<ESC> [> 5 h - to Set Mode (PSM) or blank cursor

<ESC> [> 5 l* - to Reset (PRM) or display cursor

Alternate sequences:

<ESC> [l v - to blank cursor

<ESC> [Ø v - to display cursor

The alternate command sequences can be used on terminals with V2.6 and subsequent software only. Terminals with earlier versions ignore these sequences. When the cursor is blanked ("blind" cursor mode) it still exists for the software and can still be moved, etc. with standard cursor commands. The PCKP commands thus affect only the visibility of the cursor to the operator.

*Lowercase L.

PCKM (Private) Cursor Keys Mode

<ESC> [? 1 h - to Set Mode (PSM)

<ESC> [? 1 l* - to Reset Mode (PRM)

The cursor keys mode (PCKM) allows the host to specify which of two sets of character sequences will be sent by the terminal when the cursor positioning keys are pressed. In the set mode, the cursor positioning keys send application functions. In the reset mode, the cursor positioning keys send ANSI cursor control commands. (See Cursor Control Keys in Chapter 1.)

*Note: The last character in each sequence is a lower case L. In the PCKM sequence, the L is preceded by a one.

PCNF (Private) Confidence Test- HOST to Terminal

<ESC> [Pn y

The Confidence Test (PCNF) command sequence invokes one or more of a set of tests to provide confidence of proper terminal operation. Some of these tests are also executed automatically at power-up (see **Self-Test** in chapter one).

The parameter specified in the command sequence determines the type of test to be executed. Combinations of the following tests may also be performed by summing the values shown. A value of more than 127 causes the specified test(s) to be performed repeatedly, either until failure or until power is turned off. The only other way to terminate such a repeating test is to hit the unshifted 'SETUP' key once. The terminal will then return to the normal terminal mode.

<u>Pn</u>	<u>Test to Execute</u>
0 or 1	Read-Only-Memory test Setup Memory test, Screen Memory test, Host data loop-back test
2	Host Data loop back test
4	Keyboard/Printer interface loop-back test
128	Repeat selected test(s) until failure or power-off
255	Repeat ALL tests until failure or power-off

These tests can only indicate a so-called "non-fatal" error. Such an error implies that only a portion of the terminal has a problem, and that enough of the terminal's internal mechanism is still working to provide an error indication. No response can be guaranteed if "fatal" errors exist.

If any errors are found while executing a given test, the screen will be cleared and a single letter or symbol printed in the upper left-hand corner. The type of character printed will signify the nature of the problem, as follows:

<u>ERROR</u>	<u>CODE PRINTED</u>
Read-Only-Memory	@
Setup Memory	A
Screen Memory	C
Host I/O	G
Keyboard/Printer	O

Other letters or symbols indicate combinations of these errors. Such a case is treated more fully in the **Intecolor 2400 Maintenance Manual**.

PDFK (Private) Default Function Key Mode - HOST to Terminal

<ESC> [? 29 h - to Set Mode (PSM)

<ESC> [? 29 l* - to Reset Mode (PRM)

The Default Function Key Mode allows the host to specify whether function keys transmit their default values or their user-assigned values. The set state causes the function keys to transmit their default values. The reset state causes the function keys to transmit their user-assigned values. This mode does not alter the user definitions of function keys.

PFNR (Private) Function Key Rate Mode - Host to Terminal

<ESC> [? 31 h - to Set Mode (Fast Function Keys)

<ESC> [? 31 l* - to Reset Mode (Slow Function Keys)

These sequences allow the adjustment of the rate at which the characters belonging to sequences generated by function keys are transmitted to the host. In the slow mode, the characters in a function key sequence are transmitted at the rate of 60 per second. In the fast mode, the characters belonging to a function key sequence are transmitted as fast as the terminal's processing time and the baud rate will allow. Rate control is useful when a host application program uses the time between characters to distinguish text characters from characters in a command sequence.

PIDT (Private) Identify Terminal- HOST to Terminal

<ESC> Z

The Identify Terminal (PIDT) command sequence evokes the same response as the ANSI Device Attributes (DA) command sequence.

PKPA (Private) Keypad Application Mode- HOST to Terminal

<ESC> =

The Keypad Application Mode (PKPA) command sequence places the terminal in the Keypad Application Mode, which means that the auxiliary keypad keys transmit the control sequences defined in the table on page 1.17.

*Note: The last character in the sequence is a lower case L.

PKPN (Private) Keypad Numeric Mode- HOST to Terminal

<ESC> >

The Keypad Numeric Mode (PKPN) command sequence places the terminal in the Keypad Numeric Mode, which means that the numeric keypad keys transmit the ASCII codes that correspond to the characters on the keycaps.

PLOT (Private) Plot Graphics Commands- HOST to Terminal

<ESC> [Pn ; Pn ; Pn {; Pn} z

The Plot Graphics Commands (PLOT) provide you with the capability to plot points and vectors on the display screen. The basic form of the command is shown above. Up to four parameters may be present.

The first parameter specifies the type of plot to be done. There are three different plot commands, Absolute Point Plot, Relative Move, and Relative Draw. These commands represent the minimum considered necessary to easily create simple graphic displays. The three commands and their parameter values are as follows:

- (1) Absolute Point Plot
- (2) Relative Move
- (3) Relative Draw

The second, third and fourth parameters are interpreted differently for each plot mode. Certain ranges of parameters are expected by each plot mode. If a parameter is out of range the mode is aborted and the command is ignored.

The screen can be viewed as a graph with an X-axis and a Y-axis. The X-axis runs along the bottom of the screen and the Y-axis runs along the left edge of the screen. Both the X and the Y coordinates must be positive integers. A specific location on the screen is expressed as an X,Y coordinate pair. The maximum resolution is 160 horizontal by 96 vertical points known as pixels. Horizontal coordinates are expressed as positive integers in the range 0...159, and vertical coordinates are expressed as positive integers in the range 0...95.

Absolute Point Plot

<ESC> [1 ; Pn_{x-coord} ; Pn_{y-coord} z

where:

Pn_{x-coord} is in the range 0...159

Pn_{y-coord} is in the range 0...95

The Absolute Point Plot command plots a point is at a specified location on the screen. The current foreground and background colors are used. If points with a different foreground or background color are already plotted in the same character position, they will be changed to the current foreground and background colors. When a point is plotted, an internally maintained reference point is defined as having the coordinates of the point just plotted. **Relative Move** and **Relative Draw** commands will be relative to this point, which will be referred to as the current plot position.

Relative Move

<ESC> [2 ; Pn_s ; Pn_{dx} ; Pn_{dy} z

where:

Pn_s has one of the following values:

- 0 - for both delta x and delta y signed positive
- 1 - for delta x signed positive and delta y negative
- 2 - for delta x signed negative and delta y positive
- 3 - for both delta x and delta y signed negative

Pn_{dx} (delta x) is in the range 0...159

Pn_{dy} (delta y) is in the range 0...95

The Relative Move command moves a specified distance on the screen from the current plot position, then redefines the current plot position as having the coordinates of the new location. Nothing is actually plotted in this mode; only the current plot position is changed. If the specified movement would place the current plot position outside the boundary of the screen, the command sequence is aborted, and the current plot position is not changed.

Relative Draw

<ESC> [3 ; Pn_s ; Pn_{dx} ; Pn_{dy} z

where:

Pn_s has one of the following values:

- 0 - for both delta x and delta y signed positive
- 1 - for delta x signed positive and delta y negative
- 2 - for delta x signed negative and delta y positive
- 3 - for both delta x and delta y signed negative

Pn_{dx} (delta x) is in the range 0...159

Pn_{dy} (delta y) is in the range 0...95

The Relative Draw command draws a vector from the current plot position for a specified distance on the screen, then redefines the current plot position as having the coordinates of the new location. This mode redefines the position of the current plot position. If the specified movement would place the current plot position outside the boundary of the screen, the command sequence is aborted, and the current plot position is not changed.

PMRG (Private) Set Margins- HOST to Terminal and Terminal to HOST

<ESC> [Pn ; Pn r

The Set Margins (PMRG) command sequence sets the top and bottom margins of the scrolling region. The first parameter is the top limit and the second parameter is the bottom limit. Both parameters must be a numeric value between 1 and 24, inclusive, and the bottom limit must be at least one greater than the top limit. Once the scrolling region is set by this command, only the lines within the scrolling region will scroll, any lines above or below the scrolling region will remain on the display.

Messages to the operator may be displayed outside of the scrolling region by use of the CUP sequence. The cursor position within the scrolling region must first be saved with the Save Cursor Position (PCSP) command. It can then be restored to the previous position with the Restore Cursor Position (PRCP) command.

POM (Private) Origin Mode

<ESC> [? 6 h - to Set Mode (PSM)

<ESC> [? 6 l* - to Reset Mode (PRM)

The Origin Mode (POM) allows the host to specify where origin position is relative to the vertical margins. The reset state causes the origin to be the upper-left character position on the screen. The set state causes the origin to be at the upper left position within the margins. In the set state the cursor will not cross margin boundaries.

*Note: The last character in the sequence is a lower case L.

PP Previous Page- HOST to Terminal

<ESC> [V

The Previous Page (PP) command sequence displays the first page of the display memory on the terminal screen. The cursor position, the current foreground and background colors and the vertical margins for the second page are saved in memory, and these same parameters for the first page become active. These parameters for the first page are saved when a Next Page (NP) command is received.

PPFN (Private) Program Function Keys - Host to Terminal

<ESC> [Pn_{key} ; Pn₁ { ; Pn₂ . . . ; Pn_n } s

where:

Pn_{key} is a decimal number which identifies the function key being programmed. The numbers used for the keys in these commands are as follows:

<u>Key</u>	<u>Unshifted</u>	<u>Shifted</u>	<u>With Control</u>
F0 - F23	0 - 23	Unshifted value plus 32	Unshifted value plus 64

Pn₁ -
Pn_n are the decimal equivalents of the ASCII codes for the alphanumeric characters and control symbols in the string assigned to the function key by the command. See Appendix A of this manual for a listing of the ASCII Decimal Equivalents (ADE). The string assigned to a function key may not contain more than 40 codes.

This command is used when the programmer wishes to have the host define the assignments to one or more of the function keys. A separate command sequence must be issued for each key definition.

The sequence <ESC> [s may be sent to the terminal from the host in order to clear all current function key assignments.

Note that if the function key assignments are cleared or if any function key is defined by the host with a sequence including parameter values, all previous assignments, or the previous assignment for a particular key will be destroyed, unless the assignments have been made by the terminal operator from the Setup Mode and have been stored in the terminal's permanent Setup Memory. (See page 18 of this manual for details.) If a previously defined assignment has been stored in permanent memory, that assignment may be restored by the operator following the use of these commands. The RIS sequence (ESC c) is used for restoration.

This command is executed by terminals with V2.6 and subsequent software only. Terminal's with earlier software ignore the command.

PRCP (Private) Restore Cursor Position- HOST to Terminal

<ESC> 8

The Restore Cursor Position (PRCP) command sequence restores the active cursor to the position (vertical and horizontal) previously saved with the PSCP command. Video attributes (background/foreground color, underline, and blinking character) and the G0 and G1 character set assignments (SCS commands) which were in effect at the time the position was stored are also restored.

PRRC (Private) Repeat Key Control - Host to Terminal

<ESC> [? 8 l^{*} - inhibits arrow key auto repeat

<ESC> [? 8 h - enables arrow key auto repeat

The arrow keys are normally repeating keys, i. e., when held down they send their codes repeatedly. When used for scrolling in text processing, the use of these keys can cause buffer overflow unless their repeating capability is disabled. This command permits the repeat function to be switched in or out at will.

^{*}Lower case L.

PRM (Private) Reset Mode- HOST to Terminal

<ESC> [? Pn l*

The Private Reset Mode (PRM) command sequence resets one or more of the private modes within the terminal as specified by the selective parameter. At this time only one mode is implemented within the Intecolor 2400 Private Modes. The remaining parameter values are for future expansion.

The valid selective value is:

<u>Pn</u>	<u>Mode</u>	<u>Function</u>
1	PCKM	Cursor Keys
2	PAIM	ANSI Terminal Mode
6	POM	Origin Mode
7	PAWM	Auto Wrap capability
29	PDFK	Default Function Key Mode

These parameters are set by the Private Set Mode command (PSM).

*Note: The last character in the sequence is a lower case l.

PSCP (Private) Save Cursor Position- HOST to Terminal

<ESC> 7

The Save Cursor Position (PSCP) command sequence saves the current cursor position (vertical and horizontal) and video attributes (background/foreground color, underline, and blinking character) in memory, from which they may be recovered at a later time by the Restore Cursor Position (PRCP) command. The assignments to the G0 and G1 character sets, made with the (SCS) sequences, are also stored for later recovery with the (PRCP) command.

PSM (Private) Set Mode- HOST to Terminal

<ESC> [? Pn h

The Private Set Mode (PSM) command sequence sets one or more of the private modes within the terminal as specified by the selective parameter. At this time only one mode is implemented within the Intecolor 2400 Private Modes. The remaining parameter values are for future expansion.

The valid selective value is:

<u>Pn</u>	<u>Mode</u>	<u>Function</u>
1	PCKM	Cursor Keys
2	PATM	ANSI Terminal Mode
6	POM	Origin Mode
7	PAWM	Auto Wrap capability
29	PDFK	Default Function Key Mode

These parameters are reset by the Private Reset Mode command (PRM).

PUI Private Use One - Host to Terminal/Terminal to Printer

<ESC> Q chr

This sequence, together with the SS2 and SS3 sequences, is used to transmit or receive plot block clusters. The last element of the sequence is an ASCII character corresponding to a specific plot block cluster. See below on the SS2 and SS3 sequences.

RI Reverse Index- HOST to Terminal and Terminal to HOST

<ESC> M

The Reverse Index (RI) command sequence moves the current cursor position to the same horizontal position on the preceding line. If the cursor position is at the top margin, a Scroll Down (SD) is performed.

RIS Reset to Initial State- HOST to Terminal

<ESC> c

The Reset to Initial State (RIS) command sequence resets the Intecolor 2400 to its power-on state. This command sequence clears all character buffers, unlocks the keyboard, and sets the video attributes to the default values (normal characters, green on black background). The terminal assumes the set up configuration stored in permanent memory.

RM Reset Mode- HOST to Terminal

<ESC> [Pn ; Pn ... Pn l*

The Reset Mode (RM) command sequence resets one or more of the ANSI modes within the terminal as specified by the selective parameter. Each mode to be reset is specified by a separate parameter. Up to nine parameters may be included in one command sequence. The valid selective values are:

*Note: The last character in the sequence is a lower case L.

<u>Pn</u>	<u>Mode</u>	<u>Function</u>
2	KAM	Keyboard Action Mode - if set, this mode locks the keyboard
3	CRM	Control Representation Mode - if set, this mode causes controls to have a graphic representation on the display screen
12	SRM	Send-Receive Mode - if reset, each character entered at the keyboard is displayed on the display screen (see Echo feature in SET-UP Mode)
14	FETM	Format Effector Transfer Mode - if reset, command sequences and control characters are included in the data stream passed on to the auxiliary device
18	TSM	Tabulation Stop Mode - if reset, the setting and clearing of horizontal tabulation stops apply to the corresponding character positions in all lines. If set, the horizontal tabulation stops apply to each line independently.
20	LNM	Line Feed New Line Mode - if reset, the linefeed implies only vertical movement of the current cursor position. If set, the linefeed implies movement to the first position of the following line.

These parameters are set by the Set Mode command (SM).

SCS Select Character Set-

This command assigns one of three character sets to the G0 character set or to the G1 character set according to the commands listed below. The SI (0F Hex) and SO (0E Hex) control codes select which of the two assigned character sets are active at any one time. The SI control code enables the G0 character set and the SO control code enables the G1 character set.

SCS Commands

<i>usually</i> <u>G0 Sets</u>	<u>G1 Sets</u>	<u>Name</u>
<ESC> (A	<ESC>) A	U.K. Set
<ESC> (B	<ESC>) B	ASCII Set
<ESC> (0	<ESC>) 0	Special Graphics

SGR Select Graphic Rendition-

<ESC> [Pn ; Pn ... Pn m

The Select Graphic Rendition (SGR) command sequence invokes the graphic rendition specified by the parameter(s). All characters following this command in the data stream are rendered according to the selected graphic rendition until the next occurrence of the Select Graphic Rendition (SGR) command. Up to nine parameters may be sent in one command sequence.

<u>Pn</u>	<u>Meaning</u>
0	Primary Rendition (green letters on black background)
1	Fold Characters (white letters on black background)
2	Faint Characters (blue letters on black background)
4	Underscore
5	Blink
6	Blink
7	Reverse Image (background and foreground colors swapped)
8	Concealed Characters
30	Black Foreground
31	Red Foreground
32	Green Foreground
33	Yellow Foreground
34	Blue Foreground
35	Magenta Foreground
36	Cyan Foreground
37	White Foreground
40	Black Background
41	Red Background
42	Green Background
43	Yellow Background
44	Blue Background
45	Magenta Background
46	Cyan Background
47	White Background

SM Set Mode- HOST to Terminal

<ESC> [Pn ; Pn ... Pn h

The Set Mode (SM) command sequence sets one or more of the ANSI modes within the terminal as specified by the selective parameter. Each mode to be set is specified by a separate parameter. Up to nine parameters may be included in one command sequence. The valid selective values are:

<u>Pn</u>	<u>Mode</u>	<u>Function</u>
2	KAM	Keyboard Action Mode - if set, this mode locks the keyboard
3	CRM	Control Representation Mode - if set, this mode causes controls to have a graphic representation on the display screen
12	SRM	Send-Receive Mode - if reset, each character entered at the keyboard is displayed on the display screen (see Echo feature in SET-UP Mode)
14	FETM	Format Effector Transfer Mode - if reset, command sequences and control characters are included in the data stream passed on to the auxiliary device
18	TSM	Tabulation Stop Mode - if reset, the setting and clearing of horizontal tabulation stops apply to the corresponding character positions in all lines. If set, the horizontal tabulation stops apply to each line independently.
20	LNM	Line Feed New Line Mode - if reset, the linefeed implies only vertical movement of the current cursor position. If set, the linefeed implies movement to the first position of the following line.

These parameters are reset by the Reset Mode command (RM).

SRM Send-Receive Mode- HOST to Terminal

<ESC> [12 h - to Set Mode (SM)

<ESC> [12 l* - to Reset Mode (RM)

The Send-Receive Mode (SRM) is a parameter that is controlled by the Set Mode (SM) and Reset Mode (RM) ANSI sequences. When the SRM is in the reset state there is a logical connection between the keyboard and the display screen which causes the terminal to display or echo each character or command that is entered at the keyboard. However, when the SRM is in the set state the keyboard and the display screen are logically independent from each other which causes the terminal to send the keyboard input to the host only, which means the host must echo anything that is to be displayed on the terminal.

*Note: The last character in the sequence is a lower case L.

SS2 Single Shift Two - Host to Terminal/Terminal to Printer

<ESC> N chr

This sequence (together with the sequences PUL and SS3) is used to transmit and receive CRT displays composed of plot block clusters. The last element in the sequence is an ASCII character (20 Hex - 7E Hex). When this character is specified, the sequence defines one of the 256 clusters displayable in a character space on the screen. The table on the pages following gives the sequence assigned to each cluster.

When a PUL, SS2 or SS3 sequence is received at the terminal's Host port, the corresponding plot block cluster is displayed at the current cursor position with the current foreground and background colors.

When the contents of a page of display memory are transmitted to a printer using the Page Print key, every memory representation of a plot block cluster is converted to a PUL, SS2 or SS3 ASCII sequence before being transmitted. Accordingly, displays containing points and vectors can be reproduced on an appropriately equipped and programmed intelligent printer by using these sequences. In general, they should not be used when the printer connected does not respond to ANSI control sequences.

Note: The PUL, SS2 and SS3 sequences are interpreted and generated by V2.5 and subsequent terminals only.

SS3 Single Shift Three - Host to Terminal/Terminal to Printer

<ESC> O chr

This sequence (together with the PUL and SS2 sequences) is used to transmit and receive CRT displays composed of plot block clusters. See the description above (SS2) and the pages following.

Table of PUI, SS2 and SS3 Sequences

In the tables below and on the following pages, each of the 256 displayable plot block clusters is correlated with a PUI, SS2 or SS3 sequence. To determine the sequence for a given cluster, first look to the top of the column in which it appears to find the sequence introducer (ESC N, ESC O or ESC Q). Then look to the left of the row in which it appears to find the ASCII character which closes the sequence.

	ESC N	ESC O	ESC Q	ESC N	ESC O	ESC Q	ESC N	ESC O	ESC Q
SP	[]	[]	[]	+	[]	[]	6	[]	[]
	[]	[]	[]		[]	[]		[]	[]
	[]	[]	[]		[]	[]		[]	[]
	[]	[]	[]		[]	[]		[]	[]
!	[]	[]	[]	,	[]	[]	7	[]	[]
	[]	[]	[]		[]	[]		[]	[]
	[]	[]	[]		[]	[]		[]	[]
	[]	[]	[]		[]	[]		[]	[]
"	[]	[]	[]	-	[]	[]	8	[]	[]
	[]	[]	[]		[]	[]		[]	[]
	[]	[]	[]		[]	[]		[]	[]
	[]	[]	[]		[]	[]		[]	[]
#	[]	[]	[]	.	[]	[]	9	[]	[]
	[]	[]	[]		[]	[]		[]	[]
	[]	[]	[]		[]	[]		[]	[]
	[]	[]	[]		[]	[]		[]	[]
\$	[]	[]	[]	/	[]	[]	:	[]	[]
	[]	[]	[]		[]	[]		[]	[]
	[]	[]	[]		[]	[]		[]	[]
	[]	[]	[]		[]	[]		[]	[]
%	[]	[]	[]	0	[]	[]	,	[]	[]
	[]	[]	[]		[]	[]		[]	[]
	[]	[]	[]		[]	[]		[]	[]
	[]	[]	[]		[]	[]		[]	[]
&	[]	[]	[]	1	[]	[]	<	[]	[]
	[]	[]	[]		[]	[]		[]	[]
	[]	[]	[]		[]	[]		[]	[]
	[]	[]	[]		[]	[]		[]	[]
'	[]	[]	[]	2	[]	[]	=	[]	[]
	[]	[]	[]		[]	[]		[]	[]
	[]	[]	[]		[]	[]		[]	[]
	[]	[]	[]		[]	[]		[]	[]
([]	[]	[]	3	[]	[]	>	[]	[]
	[]	[]	[]		[]	[]		[]	[]
	[]	[]	[]		[]	[]		[]	[]
	[]	[]	[]		[]	[]		[]	[]
)	[]	[]	[]	4	[]	[]	?	[]	[]
	[]	[]	[]		[]	[]		[]	[]
	[]	[]	[]		[]	[]		[]	[]
	[]	[]	[]		[]	[]		[]	[]
*	[]	[]	[]	5	[]	[]	e	[]	[]
	[]	[]	[]		[]	[]		[]	[]
	[]	[]	[]		[]	[]		[]	[]
	[]	[]	[]		[]	[]		[]	[]

Table of P01, SS2 and SS3 Sequences, cont.

	ESC N	ESC O	ESC Q	ESC N	ESC O	ESC Q	ESC N	ESC O	ESC Q		
A	ESC N	ESC O	ESC Q	L	ESC N	ESC O	ESC Q	W	ESC N	ESC O	ESC Q
B	ESC N	ESC O	ESC Q	M	ESC N	ESC O	ESC Q	X	ESC N	ESC O	ESC Q
C	ESC N	ESC O	ESC Q	N	ESC N	ESC O	ESC Q	Y	ESC N	ESC O	ESC Q
D	ESC N	ESC O	ESC Q	O	ESC N	ESC O	ESC Q	Z	ESC N	ESC O	ESC Q
E	ESC N	ESC O	ESC Q	P	ESC N	ESC O	ESC Q	[ESC N	ESC O	ESC Q
F	ESC N	ESC O	ESC Q	Q	ESC N	ESC O	ESC Q	\	ESC N	ESC O	ESC Q
G	ESC N	ESC O	ESC Q	R	ESC N	ESC O	ESC Q]	ESC N	ESC O	ESC Q
H	ESC N	ESC O	ESC Q	S	ESC N	ESC O	ESC Q	^	ESC N	ESC O	ESC Q
I	ESC N	ESC O	ESC Q	T	ESC N	ESC O	ESC Q	_	ESC N	ESC O	ESC Q
J	ESC N	ESC O	ESC Q	U	ESC N	ESC O	ESC Q	`	ESC N	ESC O	ESC Q
K	ESC N	ESC O	ESC Q	V	ESC N	ESC O	ESC Q	a	ESC N	ESC O	ESC Q

Table of PUI, SS2 and SS3 Sequences, cont.

	ESC N	ESC O		ESC N	ESC O		ESC N	ESC O
b	00	00	n	00	00	x	00	00
	01	01		01	01		01	01
	02	02		02	02		02	02
	03	03		03	03		03	03
c	04	04	n	04	04	y	04	04
	05	05		05	05		05	05
	06	06		06	06		06	06
	07	07		07	07		07	07
d	08	08	o	08	08	z	08	08
	09	09		09	09		09	09
	10	10		10	10		10	10
	11	11		11	11		11	11
e	12	12	p	12	12	{	12	12
	13	13		13	13		13	13
	14	14		14	14		14	14
	15	15		15	15		15	15
f	16	16	q	16	16		16	16
	17	17		17	17		17	17
	18	18		18	18		18	18
	19	19		19	19		19	19
g	20	20	r	20	20	}	20	20
	21	21		21	21		21	21
	22	22		22	22		22	22
	23	23		23	23		23	23
h	24	24	s	24	24	-	24	24
	25	25		25	25		25	25
	26	26		26	26		26	26
	27	27		27	27		27	27
i	28	28	t	28	28		28	28
	29	29		29	29		29	29
	30	30		30	30		30	30
	31	31		31	31		31	31
j	32	32	u	32	32		32	32
	33	33		33	33		33	33
	34	34		34	34		34	34
	35	35		35	35		35	35
k	36	36	v	36	36		36	36
	37	37		37	37		37	37
	38	38		38	38		38	38
	39	39		39	39		39	39
l	40	40	w	40	40		40	40
	41	41		41	41		41	41
	42	42		42	42		42	42
	43	43		43	43		43	43

TBC Tabulation Clear- HOST to Terminal

<ESC> [Pn g

The Tabulation Clear (TBC) command sequence clears one or more tabulation stops according to the parameter(s). When horizontal tabulation stops are cleared, the effect may be only on the active line or it may be on all lines depending upon the state of the Tabulation Stop Mode (TSM). (Refer also to CTC)

<u>Pn</u>	<u>Action</u>
0	Clears the horizontal tabulation stop at the current cursor position (default)
1	Clears the vertical tabulation stop at the current line
2	Clears all horizontal tabulation stops in the current line
3	Clears all horizontal tabulation stops
4	Clears all vertical tabulation stops

TSM Tabulation Stop Mode- HOST to Terminal

<ESC> [18 h - to Set Mode (SM)

<ESC> [18 l* - to Reset Mode (RM)

The Tabulation Stop Mode (TSM) is a parameter that is controlled by the Set Mode (SM) and Reset Mode (RM) ANSI sequences. When the Tabulation Stop Mode is in the reset state the setting and clearing of horizontal tabulation stops applies to the corresponding character position on all the lines. When the TSM is in the set state the horizontal tabulation stops are independent for each line, e.g. line 1 might have tabulation stops at columns 5, 25, and 50, while line 2 might have tabulation stops at columns 10, 30, 50, and 75.

*Note: The last character in the sequence is a lower case L.

VTS Vertical Tabulation Set- HOST to Terminal and Terminal to HOST

<ESC> J

The Vertical Tabulation Set (VTS) command sequence sets a vertical tabulation stop at the current line.

PART FIVE

PART FIVE: VT52 MODE OPERATION

In normal operation host/terminal communications are handled according to the ANSI X3.64 protocol, as determined in Setup Mode. However, the terminal's operation can be adapted to DEC VT52 compatible systems which use a restricted version of the ANSI protocol along with some device specific commands.

VT52 Mode is selected by entering Setup Mode and setting item N to "NO" and then exiting Setup Mode. Alternately, VT52 Mode can be selected while the terminal is in ANSI Mode by having the host send the ANSI PATM sequence <ESC>[?2h.

Once the terminal is in VT52 Mode, it may be returned to ANSI Mode in any one of the following three ways:

- 1) by having the host send the ANSI PATM sequence <ESC>[?21*
- 2) by having the host send the VT52 sequence <ESC><
- 3) by selecting Setup Mode, setting Setup Menu item N to "YES", and returning the terminal to ANSI Mode

Command Sequences which Replace ANSI Sequences

While in VT52 Mode the terminal responds to all ANSI sequences described in the preceding section except those listed by mnemonic in the left column of the table below. The ANSI sequences listed are replaced with the VT52 sequences listed in the right column.

<u>ANSI Mnemonic</u>	<u>Function</u>	<u>VT52 Sequence</u>
CUU	Cursor Up	<ESC> A
CUD	Cursor Down	<ESC> B
CUF	Cursor Right	<ESC> C
CUB	Cursor Left	<ESC> D
CUP	Cursor to Home	<ESC> H
ED	Erase to end of screen	<ESC> J
EL	Erase to end of line	<ESC> K
HVP	Direct cursor address	<ESC> Ylc**
PCDP	Enter Blind Cursor Mode	<ESC> x 5
PCDP	Exit Blind Cursor Mode	<ESC> y 5

*Note: Lower case L.

**Note: l = the ASCII character whose decimal equivalent is the line number plus 32
c = the ASCII character whose decimal equivalent is the column number plus 32

Auxiliary Keypad Keys

<u>Key</u>	<u>Keypad Numeric Mode</u>	<u>Keypad Application Mode</u>
0	0	<ESC> ?p
1	1	<ESC> ?q
2	2	<ESC> ?r
3	3	<ESC> ?s
4	4	<ESC> ?t
5	5	<ESC> ?u
6	6	<ESC> ?v
7	7	<ESC> ?w
8	8	<ESC> ?x
9	9	<ESC> ?y
-	-	<ESC> ?m
'	'	<ESC> ?l
.	.	<ESC> ?n
ENTER	<CR>	<ESC> ?M
PF1	<ESC> P	<ESC> P
PF2	<ESC> Q	<ESC> Q
PF3	<ESC> R	<ESC> R
PF4	<ESC> S	<ESC> S

Erase Keys

Erase Page	<ESC> J
Erase Line	<ESC> K

APPENDICES

Appendix A: ASCII Code

THE ASCII CODE

Hex Code	Char	ADE	Hex Code	Char	ADE	Hex Code	Char	ADE	Hex Code	Char	ADE
00	NUL	0	20	SP	32	40	@	64	60	'	96
01	SOH	1	21	!	33	41	A	65	61	a	97
02	STX	2	22	"	34	42	B	66	62	b	98
03	ETX	3	23	#	35	43	C	67	63	c	99
04	EOT	4	24	\$	36	44	D	68	64	d	100
05	ENQ	5	25	%	37	45	E	69	65	e	101
06	ACK	6	26	&	38	46	F	70	66	f	102
07	BEL	7	27	'	39	47	G	71	67	g	103
08	BS	8	28	(40	48	H	72	68	h	104
09	HT	9	29)	41	49	I	73	69	i	105
0A	LF	10	2A	*	42	4A	J	74	6A	j	106
0B	VT	11	2B	+	43	4B	K	75	6B	k	107
0C	FF	12	2C	,	44	4C	L	76	6C	l	108
0D	CR	13	2D	-	45	4D	M	77	6D	m	109
0E	SO	14	2E	.	46	4E	N	78	6E	n	110
0F	SI	15	2F	/	47	4F	O	79	6F	o	111
10	DLE	16	30	0	48	50	P	80	70	p	112
11	DC1*	17	31	1	49	51	Q	81	71	q	113
12	DC2	18	32	2	50	52	R	82	72	r	114
13	DC3**	19	33	3	51	53	S	83	73	s	115
14	DC4	20	34	4	52	54	T	84	74	t	116
15	NAK	21	35	5	53	55	U	85	75	u	117
16	SYN	22	36	6	54	56	V	86	76	v	118
17	ETB	23	37	7	55	57	W	87	77	w	119
18	CAN	24	38	8	56	58	X	88	78	x	120
19	EM	25	39	9	57	59	Y	89	79	y	121
1A	SUB	26	3A	:	58	5A	Z	90	7A	z	122
1B	ESC	27	3B	;	59	5B	[91	7B	{	123
1C	FS	28	3C	<	60	5C	\	92	7C		124
1D	GS	29	3D	=	61	5D]	93	7D	}	125
1E	RS	30	3E	>	62	5E	^	94	7E	~	126
1F	US	31	3F	?	63	5F	_	95	7F	DEL	127

*XON

**XOFF

Appendix A: ASCII Code

Expanded Table of ASCII Control Codes

<u>ASCII Symbol</u>	<u>Keyboard Keys</u>	<u>Conventional Meaning</u>	<u>Binary Code</u>	<u>Hex Code</u>	<u>Octal Code</u>	<u>Decimal Code</u>
<NUL>	(Control @)	Time Delay	P0000000	00	000	0
<SOH>	(Control A)	Start of Header	P0000001	01	001	1
<STX>	(Control B)	Start of Text	P0000010	02	002	2
<ETX>	(Control C)	End of Text	P0000011	03	003	3
<EOT>	(Control D)	End of Transmission	P0000100	04	004	4
<ENQ>	(Control E)	Enquire	P0000101	05	005	5
<ACK>	(Control F)	Acknowledge	P0000110	06	006	6
<BEL>	(Control G)	Sound Bell	P0000111	07	007	7
<BS>	BACKSPACE					
<HT>	(Control H) TAB)	Backspace	P0001000	08	010	8
<LF>	(Control I) LINEFEED	Horizontal Tab	P0001001	09	011	9
<VT>	(Control J)	Linefeed	P0001010	0A	012	10
<FF>	(Control K)	Vertical Tab	P0001011	0B	013	11
<CR>	(Control L) RETURN	Form Feed	P0001100	0C	014	12
<SO>	(Control M)	Carriage Return	P0001101	0D	015	13
<SI>	(Control N)	Shift Out	P0001110	0E	016	14
<DLE>	(Control O)	Shift In	P0001111	0F	017	15
<DC1>	(Control P)	Data Link Escape	P0010000	10	020	16
<DC2>	(Control Q)	Device Control 1 XON	P0010001	11	021	17
<DC3>	(Control R)	Device Control 2 XOFF	P0010010	12	022	18
<DC4>	(Control S)	Device Control 3	P0010011	13	023	19
<NAK>	(Control T)	Device Control 4	P0010100	14	024	20
<SYN>	(Control U)	Negative Acknowledge	P0010101	15	025	21
<ETB>	(Control V)	Synchronization	P0010110	16	026	22
<CAN>	(Control W)	End Transmission Block	P0010111	17	027	23
	(Control X)	Cancel	P0011000	18	030	24
<SUB>	(Control Y)	End of Medium	P0011001	19	031	25
<ESC>	(Control Z) ESC	Substitute	P0011010	1A	032	26
<FS>	(Control [)	Escape (CSI)	P0011011	1B	033	27
<GS>	(Control \)	Field Separator	P0011100	1C	034	28
<RS>	(Control])	Group Separator	P0011101	1D	035	29
<US>	(Control ^)	Record Separator	P0011110	1E	036	30
	(Control _)	Unit Separator	P0011111	1F	037	31

GLOSSARY OF TERMS (ANSI)

Active position - The character position in the visual display that is to display the graphic symbol representing the next graphic character.

Character position - That portion of a visual display which is displaying or is capable of displaying a graphic symbol.

Control character - A character whose occurrence in a particular context initiates, modifies, or stops a control function.

Control function - An action that affects the processing, transmission, format, or interpretation of data.

Control sequence - A sequence of characters that is used for control purposes to perform a control function, that begins with the control sequence introducer (CSI) control, and that may contain a parameter string.

Control sequence introducer (CSI) - An escape sequence that provides supplementary controls and that is itself a prefix affecting the interpretation of a limited number of contiguous characters.

Control string - A string of characters that is used to perform a control function and that is delimited by an opening and closing delimiter control.

Current Cursor Position - The next position on the visual display where a graphic character will be placed. (see Active Position)

Cursor - A visual representation of the active position which is a blinking underline.

Cursor control - An editor function that moves the active position.

Default - A function-dependent value that is assumed when no explicit value, or a value of \emptyset , is specified.

Display - The current active area of the screen, i.e., the area inside the scrolling region, or the entire screen if no scrolling region is specified.

Editor function - A control that affects the layout or positioning of previously entered or received information in a printing or cathode ray tube device and that is intended to be interpreted and executed without remaining in the data stream. (See format effector.)

Escape character (ESC) - A control character that provides supplementary characters (code extension) and that is itself a prefix affecting the interpretation of a limited number of contiguous characters.

Escape sequence - A sequence of characters that is used for control purposes to perform a control function and whose first character is the escape <ESC> control character.

Final character - A character whose bit combination terminates an escape or control sequence.

Format effector - A control that affects the layout or positioning of information on the screen and that may remain in the data stream subsequent to interpretation and processing. (See editor function.)

Graphic character - A character, other than a control character, that has a visual representation normally handwritten, printed, or displayed.

Home - The character position at the origin, which is the uppermost and leftmost position within the display.

Numeric parameter - A string of bit combinations that represent a number.

Parameter - (1) A string of one or more characters that represent a single value: (2) The value so represented. (Designated by Pn).

Parameter string - A string of characters that represent one or more parameter values.

Selective parameter - A string of bit combinations that selects a subfunction from a specified list of subfunctions.

Appendix C: Terminal Control Codes

TERMINAL CONTROL CODES AND THEIR ACTIONS

<u>Code</u>	<u>Selectable Recognition</u>	<u>Function</u>
<BEL>		Causes terminal's audible indicator to sound
<BS>		Causes cursor to move one space to the left
<CAN>		Cancels multi-character control sequence
<CR>		Causes the cursor to move to the left margin of the current line. If item D "New Line" is selected in Setup Mode, <CR> is interpreted as <CR><LF>.
<DC1>	Yes	Causes the terminal to resume sending to the host (same as XON)
<DC3>	Yes	Causes the terminal to stop sending to the host (same as XOFF)
<ENQ>	Yes	Causes the terminal to send its answerback message to the host.
<FF>		Same as <CR>
<HT>		Causes cursor to move one tab stop to the right
<LF>		Causes the cursor to move down one line
<SI>		Causes the terminal's alternate character set to be used for text display. When the terminal is in 4027 Mode, only the monitor display is affected. (See SCS in Part Six.)
<SO>		Causes the terminal to revert to its normal character set for text display (monitor only in 4027 Mode).
<VT>		Causes the cursor to move up one line

SUMMARY OF
ANSI CONTROL SEQUENCES
(In order by Mnemonic)

CBT Cursor Backward Tabulation-	ESC [Pn Z
CHT Cursor Horizontal Tabulation-	ESC [Pn I
CPR Cursor Position Report-	ESC [Pn ; Pn R
CRM Control Representation Mode-	ESC [3 h ESC [3 l*
CTC Cursor Tabulation Control-	ESC [Pn W
CUB Cursor Backward-	ESC [Pn D
CUD Cursor Downward-	ESC [Pn B
CUF Cursor Forward-	ESC [Pn C
CUP Cursor Position-	ESC [Pn ; Pn H
CUU Cursor Up-	ESC [Pn A
CVT Cursor Vertical Tabulation-	ESC [Pn Y
DA Device Attributes-	ESC [Pn c
DSR Device Status Report-	ESC [Pn n
ED Erase In Display-	ESC [Pn J
EL Erase In Line-	ESC [Pn K
HTS Horizontal Tabulation Set-	ESC H
HVP Horizontal & Vertical Position-	ESC [Pn ; Pn f
IND Index-	ESC D
KAM Keyboard Action Mode-	ESC [2 h ESC [2 l*
LNM Line Feed New Line Mode-	ESC [20 h ESC [20 l*

**Appendix D: ANSI Command
Summary - by Mnemonic**

MC Media Copy-	ESC [Pn i
NEL Next Line-	ESC E
NP Next Page-	ESC [U
PALN (Private) Screen Alignment Display-	ESC # 8
PATM (Private) ANSI Terminal Mode-	ESC [? 2 h ESC [? 2 l*
PAWM (Private) Auto Wrap Mode-	ESC [? 7 h ESC [? 7 l*
PCDP (Private) Cursor Display Mode-	ESC [> 5 h ESC [> 5 l*
	or ESC [l v ESC [Ø v
PKM (Private) Cursor Keys Mode-	ESC [? 1 h ESC [? 1 l*
PCNF (Private) Confidence Test-	ESC [Pn y
PDFK (Private) Default Function Key Mode-	ESC [? 29 h ESC [? 29 l*
PFNR (Private) Function Key Rate Mode-	ESC [? 31 h ESC [? 31 l*
PIDT (Private) Identify Terminal-	ESC Z
PKPA (Private) Keypad Application Mode-	ESC =
PKPN (Private) Keypad Numeric Mode-	ESC >
PLOT (Private) Plot Graphics Commands-	ESC [Pn;Pn;Pn;Pn z
PMRG (Private) Set Margins-	ESC [Pn ; Pn r
POM (Private) Origin Mode-	ESC [? 6 h ESC [? 6 l*
PP Previous Page-	ESC [V
PPFN (Private) Program Function Keys-	ESC [Pn _{key} {;Pn ₁ ...;Pn _n } s
PRCP (Private) Restore Cursor Position-	ESC 8
PRKC (Private) Repeat Key Control	ESC [? 8 h ESC [? 8 l*
PRM (Private) Reset Mode-	ESC [? Pn l*

**Appendix D: ANSI Command
Summary - by Mnemonic**

PRPT (Private) Request/Report Terminal Parameters-	ESC [Pn ; ... Pn x
PSCP (Private) Save Cursor Position-	ESC 7
PSM (Private) Set Mode-	ESC [? Pn h
PUL (Private) Use One-	ESC Q chr
RI Reverse Index-	ESC M
RIS Reset to Initial State-	ESC c
RM Reset Mode-	ESC [Pn ; ... Pn l*
SGR Select Graphic Rendition-	ESC [Pn ; ... Pn m
SM Set Mode-	ESC [Pn ; ... Pn h
SRM Send-Receive Mode-	ESC [12 h ESC [12 l*
SS2 Single Shift Two	ESC N chr
SS3 Single Shift Three	ESC O chr
TBC Tabulation Clear-	ESC [Pn g
TSM Tabulation Stop Mode-	ESC [18 h ESC [18 l*
VTS Vertical Tabulation Set-	ESC J

*Note: The character is a lower case L.

SUMMARY
OF ANSI CONTROL SEQUENCES
(In Order by Function)

Cursor Positioning:

CUU	Cursor Up-	ESC [Pn A
CUD	Cursor Downward-	ESC [Pn B
CUF	Cursor Forward-	ESC [Pn C
CUB	Cursor Backward-	ESC [Pn D
CUP	Cursor Position-	ESC [Pn ; Pn H
PSCP	(Private) Save Cursor Position-	ESC 7
PRCP	(Private) Restore Cursor Position-	ESC 8
CPR	Cursor Position Report-	ESC [Pn ; Pn R
HVP	Horizontal & Vertical Position-	ESC [Pn ; Pn f

Erase Screen:

ED	Erase In Display-	ESC [Pn J
EL	Erase In Line-	ESC [Pn K

Screen Scrolling, Line Movement,
and Page Switching:

IND	Index-	ESC D
RI	Reverse Index-	ESC M
NEL	Next Line-	ESC E
NP	Next Page-	ESC [U
PP	Previous Page-	ESC [V
PRKC	Arrow Key Repeat Control	ESC [? 8 h
		ESC [? 8 l

Tabulation:

CHT	Cursor Horizontal Tabulation-	ESC [Pn I
CTC	Cursor Tabulation Control-	ESC [Pn W
CVT	Cursor Vertical Tabulation-	ESC [Pn Y
CBT	Cursor Backward Tabulation-	ESC [Pn Z
TBC	Tabulation Clear-	ESC [Pn g
HTS	Horizontal Tabulation Set-	ESC H

Appendix E: ANSI Control Sequences - by Function

VTS Vertical Tabulation Set- ESC J

Terminal Reporting & Terminal States:

DA	Device Attributes-	ESC [Pn c
DSR	Device Status Report-	ESC [Pn n
PRPT	(Private) Request/Report Terminal Parameters-	ESC [Pn ; . . . Pn x
PIDT	(Private) Identify Terminal-	ESC Z
PCNF	(Private) Confidence Test-	ESC [Pn y
RIS	Reset to Initial State-	ESC c
PALN	(Private) Screen Alignment Display-	ESC # 8

Set/Reset Modes:

SM	Set Mode-	ESC [Pn ; . . . Pn h
RM	Reset Mode-	ESC [Pn ; . . . Pn l
PSM	(Private) Set Mode-	ESC [? Pn h
PRM	(Private) Reset Mode-	ESC [? Pn l
PCKM	(Private) Cursor Keys Mode-	ESC [? 1 h ESC [? 1 l
PATM	(Private) ANSI Terminal Mode-	ESC [? 2 h ESC [? 2 l
POM	(Private) Origin Mode-	ESC [? 6 h ESC [? 6 l
PAWM	(Private) Auto Wrap Mode-	ESC [? 7 h ESC [? 7 l
PRKC	(Private) Repeat Key Control	ESC [? 8 h ESC [? 8 l
PDFK	(Private) Default Function Key Mode-	ESC [? 29 h ESC [? 29 l
PFNR	(Private) Function Key Rate	ESC [? 31 h ESC [? 31 l
PCDP	(Private) Cursor Display Mode	ESC [> 5 h ESC [> 5 l
		or ESC [1 v ESC [0 v
KAM	Keyboard Action Mode-	ESC [2 h ESC [2 l
CRM	Control Representation Mode-	ESC [3 h ESC [3 l

Appendix E: ANSI Control Sequences - by Function

SRM	Send-Receive Mode-	ESC [12 h ESC [12 l
TSM	Tabulation Stop Mode-	ESC [18 h ESC [18 l
LNМ	Line Feed New Line Mode-	ESC [20 h ESC [20 l
PKPA	(Private) Keypad Application Mode-	ESC =
PKPN	(Private) Keypad Numeric Mode-	ESC >

Miscellaneous:

MC	Media Copy-	ESC [Pn i
SGR	Select Graphic Rendition-	ESC [Pn ; . . . Pn m
PMRG	(Private) Set Margins-	ESC [Pn ; Pn r
PPFN	(Private) Program Function Keys	ESC [Pn _k ; Pn ₁ . . . ; Pn _n ^s
PLOT	(Private) Plot Graphics Commands-	ESC [Pn ; Pn ; Pn ; Pn z
PUL	(Private) Use One	ESC Q chr
SS2	Single Shift Two	ESC N chr
SS3	Single Shift Three	ESC O chr

Appendix F: ANSI Control Sequences - by Code

SUMMARY

OF ANSI CONTROL SEQUENCES

(In Order by Codes)

PSCP (Private) Save Cursor Position-	ESC 7
PRCP (Private) Restore Cursor Position-	ESC 8
PKPA (Private) Keypad Application Mode-	ESC =
PKPN (Private) Keypad Numeric Mode-	ESC >
IND Index-	ESC D
NEL Next Line-	ESC E
HTS Horizontal Tabulation Set-	ESC H
VTS Vertical Tabulation Set-	ESC J
RI Reverse Index-	ESC M
SS2 Single Shift Two	ESC N chr
SS3 Single Shift Three	ESC O chr
PUL (Private) Use One	ESC Q chr
PIDT (Private) Identify Terminal-	ESC Z
RIS Reset to Initial State-	ESC c
PALN (Private) Screen Alignment Display-	ESC # 8
CUU Cursor Up-	ESC [Pn A
CUD Cursor Downward-	ESC [Pn B
CUF Cursor Forward-	ESC [Pn C
CUB Cursor Backward-	ESC [Pn D
CUP Cursor Position-	ESC [Pn ; Pn H
CHT Cursor Horizontal Tabulation-	ESC [Pn I
ED Erase In Display-	ESC [Pn J
EL Erase In Line-	ESC [Pn K
CPR Cursor Position Report-	ESC [Pn ; Pn R
NP Next Page-	ESC [U
PP Previous Page-	ESC [V
CTC Cursor Tabulation Control-	ESC [Pn W
CVT Cursor Vertical Tabulation-	ESC [Pn Y
CBT Cursor Backward Tabulation-	ESC [Pn Z
DA Device Attributes-	ESC [Pn c
HVP Horizontal & Vertical Position-	ESC [Pn ; Pn f
TBC Tabulation Clear-	ESC [Pn g
SM Set Mode-	ESC [Pn ; . . . Pn h
MC Media Copy-	ESC [Pn i
RM Reset Mode-	ESC [Pn ; . . . Pn l
SGR Select Graphic Rendition-	ESC [Pn ; . . . Pn m
DSR Device Status Report-	ESC [Pn n
PMRG (Private) Set Margins-	ESC [Pn ; Pn r
PPFK (Private) Program Function Key	ESC [Pn _k ; Pn ₁ . . . ; Pn _n s

Appendix F: ANSI Control Sequences - by Code

PRPT (Private) Request/Report Terminal Parameters-	ESC [Pn ; . . . Pn x
PCNF (Private) Confidence Test-	ESC [Pn y
PLOT (Private) Plot Graphics Commands-	ESC [Pn ; Pn ; Pn ; Pn z
PCDP (Private) Cursor Display	ESC [0 v
	ESC [1 v
KAM Keyboard Action Mode-	ESC [2 h
	ESC [2 l
CRM Control Representation Mode-	ESC [3 h
	ESC [3 l
SRM Send-Receive Mode-	ESC [12 h
	ESC [12 l
TSM Tabulation Stop Mode-	ESC [18 h
	ESC [18 l
LNM Line Feed New Line Mode-	ESC [20 h
	ESC [20 l
PCDP (Private) Cursor Display	ESC [> 5 h
	ESC [> 5 l
PSM (Private) Set Mode-	ESC [? Pn h
PRM (Private) Reset Mode-	ESC [? Pn l
PCKM (Private) Origin Mode-	ESC [? 1 h
	ESC [? 1 l
PATM (Private) ANSI Terminal Mode-	ESC [? 2 h
	ESC [? 2 l
POM (Private) Origin Mode-	ESC [? 6 h
	ESC [? 6 l
PAWM (Private) Auto Wrap Mode-	ESC [? 7 h
	ESC [? 7 l
PRKC (Private) Repeat Key Control	ESC [? 8 h
	ESC [? 8 l
PDFK (Private) Default Function Key Mode	ESC [? 29 h
	ESC [? 29 l
PFNR (Private) Function Key Rate	ESC [? 31 h
	ESC [? 31 l

TECHNICAL SPECIFICATIONS

Screen Capacity: 1920 characters

Screen Size: 13-inch diagonal

Characters per Line: 80

Character Generation: on a 6 x 12 dot matrix

Character Set: 96 character displayable ASCII subset plus graphics characters and Control Representation Mode (CRM) characters

Cursor Type: Blinking Underscore

Refresh Rate: 50 or 60 Hz

Keyboard: Electronic, 101 keys with 65 key layout similar to standard typewriter keyboard with auxiliary special function keys and an 18-key numeric pad with period, comma, minus, enter and four general-purpose function keys.

Audible Signals:

- Keyclick: Sounds each time a key is depressed (selectable)
- Bell: 1) Sounds upon receipt of BEL code
- 2) Sounds eight characters from right margin
- 3) Sounds upon keyboard buffer overflow

Line Interface: RS 232/CCITT-V.24

Speeds: Baud Rate- 16 standard rates from 50 to 19200 selectable in SET-UP mode. May have different rates for host communications and auxiliary device.

Communications: Asynchronous Serial

Character Size: 7 bits

Parity: Even, odd, or none- selectable in SET-UP

Communications Protocols: XON/XOFF control codes- selectable in SET-UP

Power Supply: 104-126V or 207-253V AC, 50-60 Hz, 100W

Operating Temperature: 0 - 40 degrees Centigrade

LIGHT PEN

As an option, the 2405 can have a light pen. Field installation and adjustment of the pen is covered in the 2400 Series Maintenance Manual. This appendix describes the use of the pen.

When the terminal is operating in the local mode, the light pen can be used to reposition the cursor without using the keyboard. When the terminal is on line and the host is appropriately programmed, the pen can be used to make picks of displayed data, to draw graphs, to reposition the cursor, etc. Installation of a light pen does not involve any changes in terminal software.

Use of the pen requires that some light be available at the position on the video screen where it is positioned. This light may be provided as a foreground or background color other than black. The pen is activated by pressing its point against the screen. It can then detect any light at the position where it is placed and cause the terminal to register this position. When the terminal has registered a light pen position it indicates the fact in one of two ways. When in the local mode, it automatically places the cursor in this position. When on line, the terminal transmits a cursor position escape sequence (CUP) to its host. The host responds to this sequence in accordance with its program. It could simply echo the sequence, in which case the terminal would reposition the cursor, or it could respond with some other command. When the terminal is on line and operating in the Echo mode, the escape sequence is transmitted to the host and the cursor is repositioned.

Note: Most light pens are most sensitive to blue and least sensitive to red light. Some pens will not respond readily to a spot of red the size of a period, but most are capable of responding to a character like "e" displayed in red on a black background.

SCHEMATIC DIAGRAMS

8

7

6

5

4

3

2

1

REVISIONS			
REV	DESCRIPTION	DATE	APPROVED
1	ENG. RELEASE	2912	1-11-83 <i>ESG/MLB</i>

00 CONT @	01 CONT A	02 CONT B	03 CONT C	04 CONT D	05 CONT E	06 CONT F	07 CONT G	08 CONT H	09 CONT I	0A CONT J	0B CONT K	0C CONT L	0D CONT M	0E CONT N	0F CONT O	0G CONT P	0H CONT Q	0I CONT R	0J CONT S	0K CONT T	0L CONT U	
01 2 3 4 5 6 7 8 9 A B																						
16 CONT V	17 CONT W	18 CONT X	19 CONT Y	1A CONT Z	1B CONT [1C CONT \	1D CONT]	1E CONT ^	1F CONT _	20 SPACE	21 !	22 "	23 #	24 \$	25 %	26 &	27 '	28 (29)	2A *	2B +	
01 2 3 4 5 6 7 8 9 A B																						
2C ,	2D -	2E .	2F /	30 0	31 1	32 2	33 3	34 4	35 5	36 6	37 7	38 8	39 9	3A :	3B ;	3C <	3D =	3E >	3F ?	40 @	41 A	
01 2 3 4 5 6 7 8 9 A B																						
42 B	43 C	44 D	45 E	46 F	47 G	48 H	49 I	4A J	4B K	4C L	4D M	4E N	4F O	50 P	51 Q	52 R	53 S	54 T	55 U	56 V	57 W	
01 2 3 4 5 6 7 8 9 A B																						
58 X	59 Y	5A Z	5B [5C \	5D]	5E ^	5F _	60 `	61 a	62 b	63 c	64 d	65 e	66 f	67 g	68 h	69 i	6A j	6B k	6C l	6D m	
01 2 3 4 5 6 7 8 9 A B																						
6E n	6F o	70 p	71 q	72 r	73 s	74 t	75 u	76 v	77 w	78 x	79 y	7A z	7B {	7C	7D }	7E ~	7F #	80-9F UNUSED				DF _
01 2 3 4 5 6 7 8 9 A B																						
E0 c	E1 d	E2 b	E3 c	E4 d	E5 e	E6 f	E7 g	E8 h	E9 i	EA j	EB k	EC l	ED m	EE n	EF o	FO p	F1 q	F2 r	F3 s	F4 t	F5 u	
01 2 3 4 5 6 7 8 9 A B																						
F6 v	F7 w	F8 x	F9 y	FA z	FB {	FC	FD }	FE ~	FF DEL													
01 2 3 4 5 6 7 8 9 A B																						

- NOTES:
1. THE NUMBER AT THE UPPER LEFT CORNER OF EACH BLOCK IS THE HEXADECIMAL REPRESENTATION OF THE EIGHT HIGH ORDER ADDRESS BITS (SR00-7) TO THE CHARACTER MEMORY, UC9.
 2. THE NUMBERS AT THE LEFT OF THE BLOCKS ARE THE HEXADECIMAL REPRESENTATIONS OF THE FOUR LOW ORDER ADDRESS BITS (RA0-3) TO THE CHARACTER MEMORY, THESE BITS SINGLE OUT THE SCAN LINES.
 3. THE CHARACTER AT THE UPPER RIGHT OF EACH BLOCK IS THE ASCII CHARACTER WHOSE CODE, FURNISHED BY THE KEYBOARD OR BY A HOST, IS USED TO DISPLAY THE CHARACTER IN THE BLOCK, DISPLAY OF THE CONTROL CODE SYMBOLS AND SPECIAL CHARACTERS (DF-FF) REQUIRES SPECIAL COMMANDS.

UNLESS OTHERWISE SPECIFIED		APPROVALS		DATE
DIMENSIONS ARE IN INCHES		DRAWN M. WESTRAY		12-16-82
TOLERANCES ARE:		CHECKED		
FRACTIONS	DECIMALS	ENG		
±	±			
MATERIAL				
FINISH				
DO NOT SCALE DRAWING				
 CHARACTER SET 2405				
PROPRIETARY		SIZE		REV
This document, submitted in confidence, contains proprietary information which shall not be reproduced or transferred to other documents or disclosed to others or used for manufacturing or any other purpose without prior written permission of Intelligent Systems.		D		1
		DRAWING NO.		
		102307		
		SCALE		SHEET 1 OF 1

8

7

6

5

4

3

2

1

JUMPER #	INSTALL FOR
W1	50% MODULATION OF VIDEO
W2	100% MODULATION OF VIDEO
W3	FIXED CTS TO KEYBOARD
W4	CONTROLLABLE CTS TO KEYBOARD
W5	FOR ACTIVE LOW VIDEO
W6	FOR ACTIVE HIGH VIDEO
W7	2732 AND 2764 EPROMS
W8	2716 EPROM
W9	2K X 8 STATIC RAM
W10	PAGE MODE ADDRESSING OF REFRESH RAM
W11	LINEAR MODE ADDRESSING OF REFRESH RAM
W12	EXTERNAL RECEIVE CLOCK
W13	EXTERNAL TRANSMIT CLOCK
W14	TO OUTPUT XMIT CLOCK

REVISONS				REV	DESCRIPTION	ECN	DATE	APPROVED	REV	DESCRIPTION	ECN	DATE	APPROVED
5	SEE ECN	3098	8/2/83	1	ENG. RELEASE				1		2781	9/2/82	
6	SEE ECN	3124/3159	9/19/83	2	SEE ECN				2		2806	10/21/82	
				3	SEE ECN				3		2938	2/28/85	
				4	SEE ECN				4		2864	4-28/87	

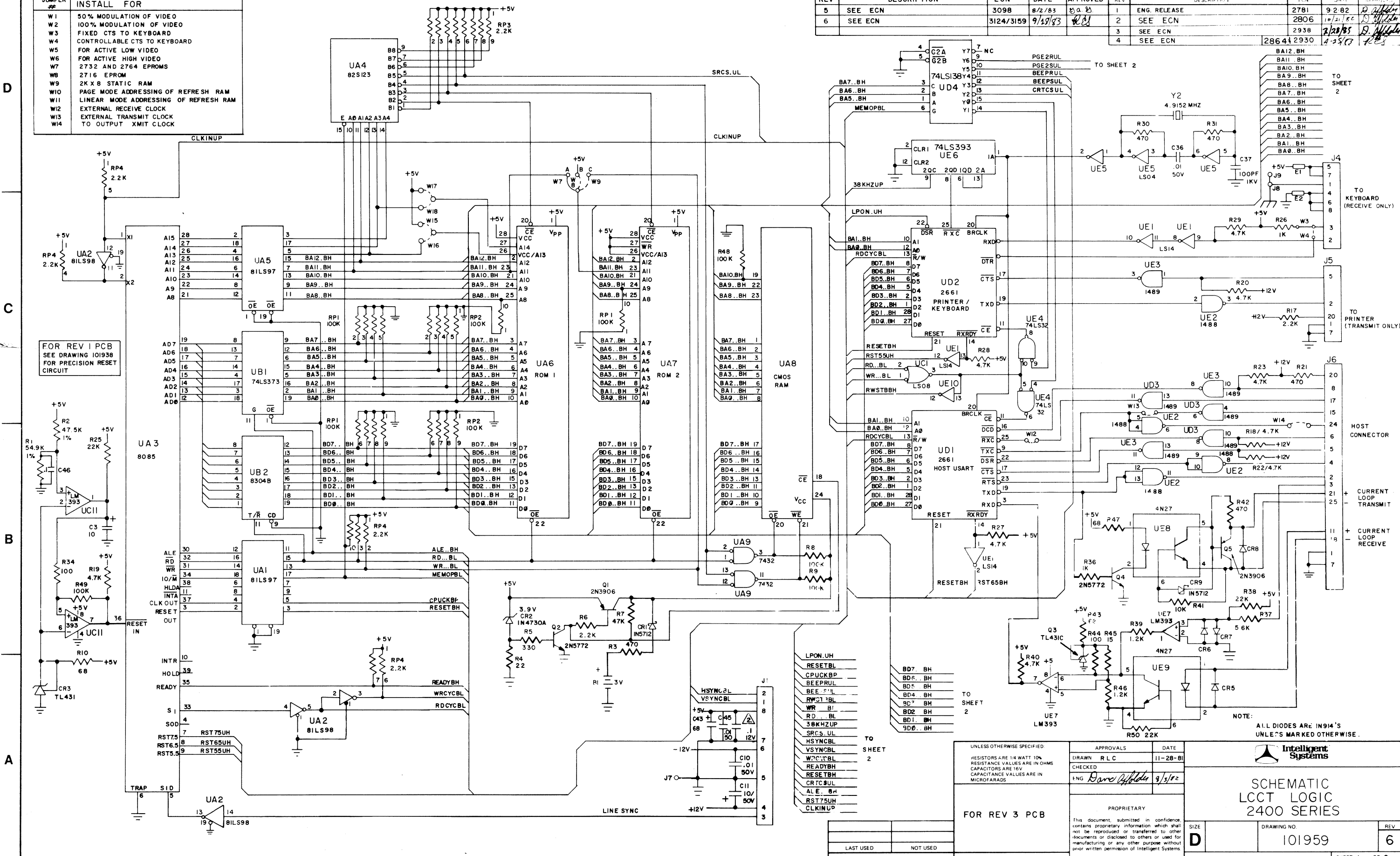

FOR REV 1 PCB
SEE DRAWING 101938
FOR PRECISION RESET
CIRCUIT

FOR REV 3 PCB

UNLESS OTHERWISE SPECIFIED:	
RESISTORS ARE 1/4 WATT 10% RESISTANCE VALUES ARE IN OHMS	
CAPACITORS ARE 16V CAPACITANCE VALUES ARE IN MICROFARADS	

APPROVALS		DATE
DRAWN RLC	CHECKED	11-28-81
ENG Dave Affelder		9/5/82

PROPRIETARY
This document submitted in confidence, contains proprietary information which shall not be reproduced or transferred to other documents or disclosed to others or used for manufacturing or any other purpose without prior written permission of Intelligent Systems.

SIZE	D	DRAWING NO.	101959	REV	6
------	---	-------------	--------	-----	---

Intelligent Systems
SCHEMATIC LCCT LOGIC 2400 SERIES

D
C
B
A

D
C
B
A

REVISIONS				
REV	DESCRIPTION	ECN	DATE	APPROVAL
1	ENG. RELEASE	2781	9-2-82	[Signature]
2	SEE ECN	2806	10/21/82	[Signature]
3	SEE ECN	2938	1/28/83	[Signature]
4	SEE ECN	2864	4-25-83	[Signature]
5	SEE ECN	3098	[Signature]	[Signature]
6	SEE ECN	3124 / 3159	9/28/83	[Signature]

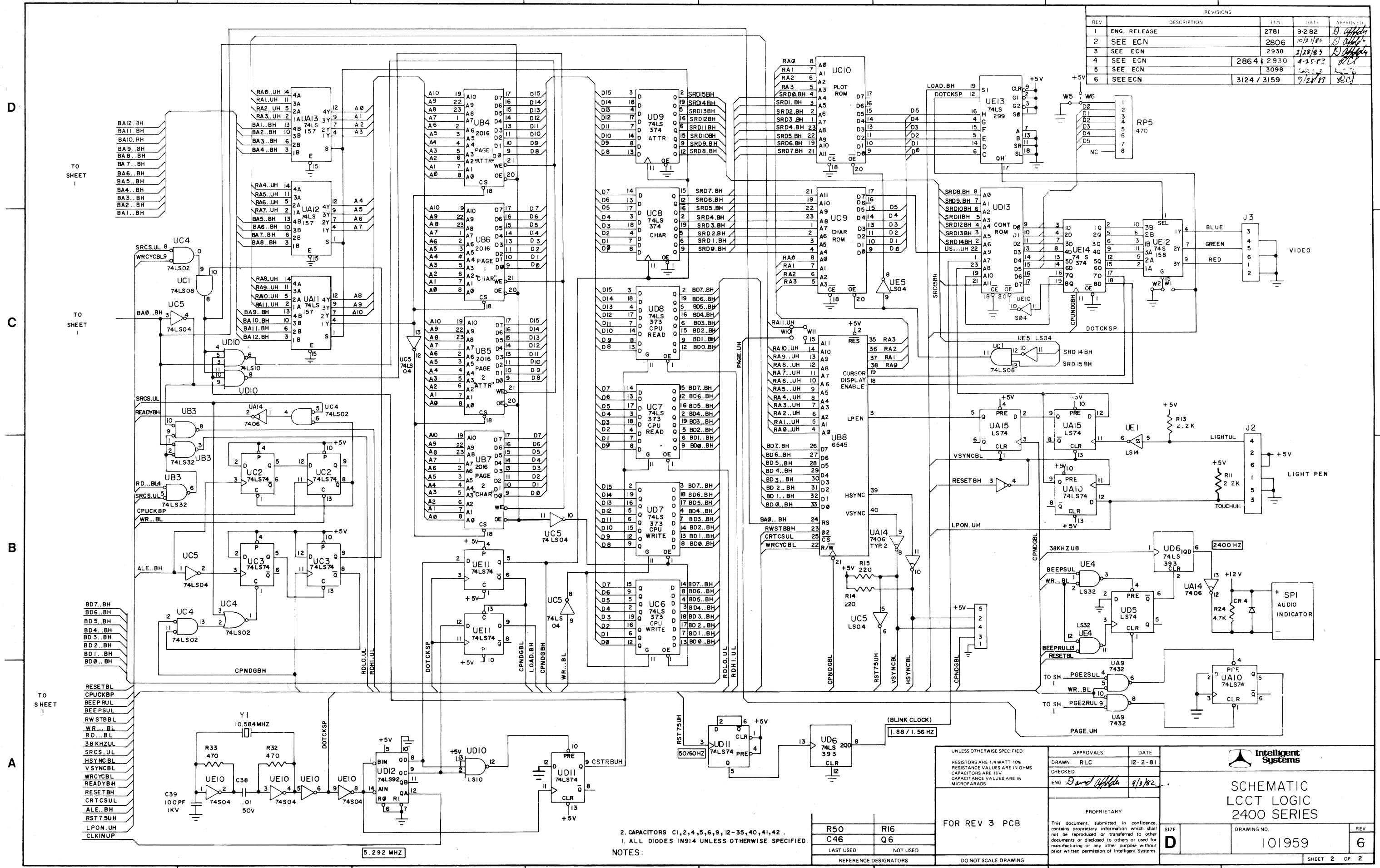

2. CAPACITORS C1,2,4,5,6,9,12-35,40,41,42 .
 1. ALL DIODES IN914 UNLESS OTHERWISE SPECIFIED.

R50	R16
C46	Q6
LAST USED	NOT USED
REFERENCE DESIGNATORS	

FOR REV 3 PCB
 DO NOT SCALE DRAWING

APPROVALS		DATE
DRAWN	RLC	12-2-81
CHECKED		
ENG	[Signature]	9/3/82

Intelligent Systems

SCHEMATIC LCCT LOGIC 2400 SERIES

PROPRIETARY

This document, submitted in confidence, contains proprietary information which shall not be reproduced or transferred to other documents or disclosed to others or used for manufacturing or any other purpose without prior written permission of Intelligent Systems.

SIZE	DRAWING NO.	REV
D	101959	6

SHEET 2 OF 2

REVISIONS				
REV	DESCRIPTION	ECN	DATE	APPROVED
1	ENG. RELEASE	2783	9-2-82	DLT
2	SEE ECN	NEW 2899	3-8-83	TCJ

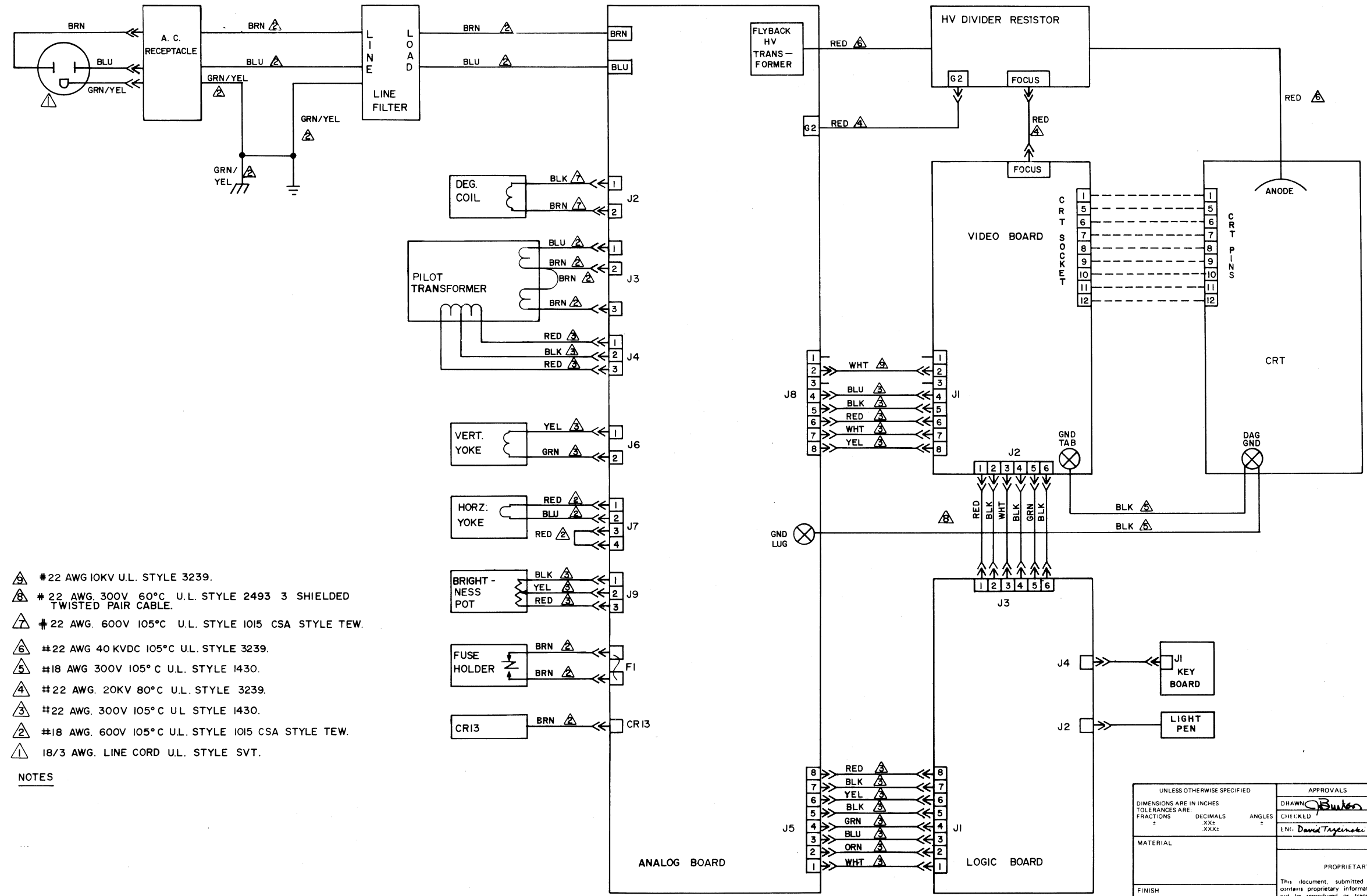

- NOTES
- ① #22 AWG 10KV U.L. STYLE 3239.
 - ② #22 AWG. 300V 60°C U.L. STYLE 2493 3 SHIELDED TWISTED PAIR CABLE.
 - ③ #22 AWG. 600V 105°C U.L. STYLE 1015 CSA STYLE TEW.
 - ④ #22 AWG 40 KVDC 105°C U.L. STYLE 3239.
 - ⑤ #18 AWG 300V 105°C U.L. STYLE 1430.
 - ⑥ #22 AWG. 20KV 80°C U.L. STYLE 3239.
 - ⑦ #22 AWG. 300V 105°C U.L. STYLE 1430.
 - ⑧ #18 AWG. 600V 105°C U.L. STYLE 1015 CSA STYLE TEW.
 - ⑨ 18/3 AWG. LINE CORD U.L. STYLE SVT.

UNLESS OTHERWISE SPECIFIED		APPROVALS		DATE
DIMENSIONS ARE IN INCHES		DRAWN <i>DBurke</i>		3/2/82
TOLERANCES ARE:		CHECKED		
FRACTIONS	DECIMALS	ENG. <i>David Trzynski</i>		9/8/82
+	XX±			
	XXX±			
MATERIAL				
FINISH				
DO NOT SCALE DRAWING				
PROPRIETARY			This document, submitted in confidence, contains proprietary information which shall not be reproduced or transferred to other documents or disclosed to others or used for manufacturing or any other purpose without prior written permission of Intelligent Systems.	
INTELLIGENT SYSTEMS		DRAWING NO. 101962		REV 2
SIZE D	SCALE <i>1/8"</i>		SHEET	OF

8 7 6 5 4 3 2 1

REVISIONS				
REV	DESCRIPTION	ECN	DATE	APPROVED
1	ENG. RELEASE	2782	92-82	DLT

FROM ANALOG

J1

6.3 VRMS

+60V

+12V

+5V

+5V

J2

FROM LOGIC

FROM FOCUS CONTROL

J3

XAI

HEATER 9

HEATER 10

G2 7

G1 5

RED CATHODE 8

GREEN CATHODE 6

BLUE CATHODE 11

GND TAB

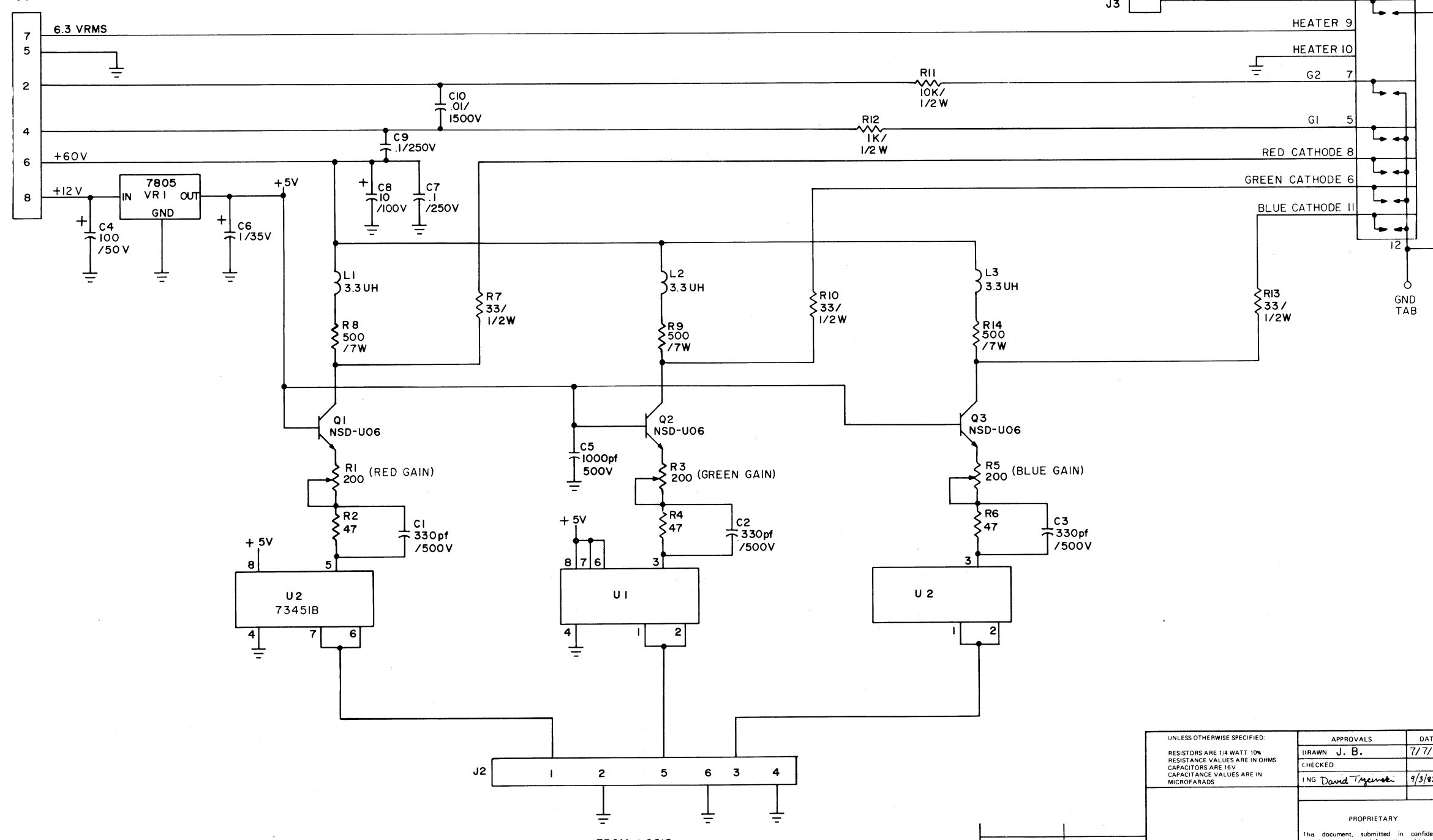

UNLESS OTHERWISE SPECIFIED: RESISTORS ARE 1/4 WATT 10% RESISTANCE VALUES ARE IN OHMS CAPACITORS ARE 16V CAPACITANCE VALUES ARE IN MICROFARADS	APPROVALS	DATE
	DRAWN J. B.	7/7/82
	CHECKED ING David Trzynski	9/3/82
PROPRIETARY		
This document, submitted in confidence, contains proprietary information which shall not be reproduced or transferred to other documents or disclosed to others or used for manufacturing or any other purpose without prior written permission of Intelligent Systems.		
LAST USED	NOT USED	
REFERENCE DESIGNATORS	DO NOT SCALE DRAWING	

SCHEMATIC LCCT VIDEO 2400 SERIES		
SIZE	DRAWING NO.	REV
D	101976	1
SHEET 1 OF 1		

8 7 6 5 4 3 2 1

8 7 6 5 4 3 2 1

REVISIONS			
REV	DESCRIPTION	LEN	DATE
1	ENG. RELEASE	3004	7/25/83

FROM ANALOG

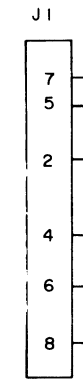

FROM FOCUS CONTROL

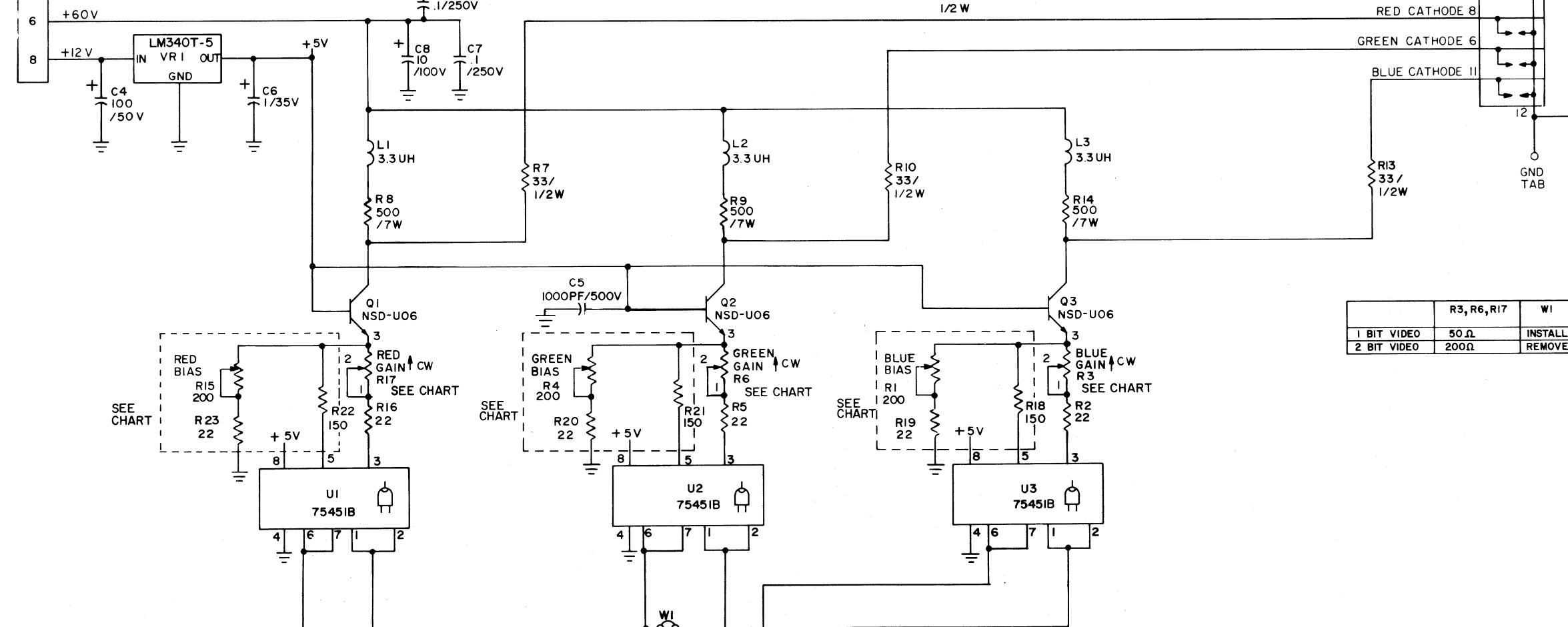
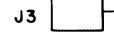

	R3, R6, R17	W1	CIRCUIT IN OUTLINE
1 BIT VIDEO	50Ω	INSTALLED	REMOVED
2 BIT VIDEO	200Ω	REMOVED	INSTALLED

SEE CHART

SEE CHART

SEE CHART

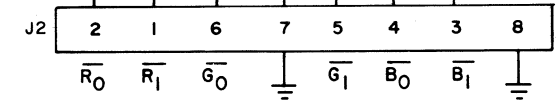

FROM LOGIC

APPROVALS		DATE
DRAWN	DKMOORE	4-6-83
CHECKED		
ENG.	<i>[Signature]</i>	5-3-83

UNLESS OTHERWISE SPECIFIED:
 - RESISTORS ARE 1/4 WATT 10%
 - RESISTANCE VALUES ARE IN OHMS
 - CAPACITORS ARE 1%
 - CAPACITANCE VALUES ARE IN MICROFARADS

PROPRIETARY
 This document submitted in confidence contains proprietary information which shall not be reproduced or transferred to other individuals or disclosed to others or used for manufacturing or any other purpose without prior written permission of Intelligent Systems.

LAST USED: NOT USED

REFERENCE DESIGNATORS: DO NOT SCALE DRAWING

Intelligent Systems

SCHEMATIC 2/1 BIT VIDEO ILVA

SIZE: **D** DRAWING NO: **102700** REV: **1**

SHEET 1 OF 1

8 7 6 5 4 3 2 1