

M71 - SERIES

MODEL 7/16 BASIC

MAINTENANCE MANUAL

GENERAL DESCRIPTION		
General Description		29-364A12
PROCESSOR		
Processor Installation Specification		01-070R01A20
Processor Maintenance Specification		01-070R01A21
SELECTOR CHANNEL		
Selector Channel Installation Specification		02-232M01R03A20
Selector Channel Maintenance Specification		02-232M02R01A21
AUTO LOADER		
Automatic Loader Information Specification		02-352A12
TEST AID		
Test Aid Information Specification		02-276R01A12
MICRO-PROGRAMS		
Micro-program Listing		05-048R01A13
DROM Micro-program Listing without Multiply/Divide		05-049F01A13
DROM Micro-program Listing with Multiply/Divide		05-049F02A13
DISPLAY PANEL		
Hexadecimal Display Panel Information Specification		09-065A12
DRAWINGS		
Processor Schematic		01-058R06D08
CPU-HI Board Component Locator		35-446R08E03
CPU-LO Board Component Locator		35-520E03
CPU-LO Board Component Locator		35-520M01E03
Selector Channel Schematic		02-232M01R03D08
Selector Channel Component Locator		35-391M02R02E03
Auto Loader Schematic		02-271R01C08
Test Aid Schematic		02-276R01D08
Basic Control Switch Panel Schematic		02-272R01B08
Hexadecimal Display Panel Schematic		09-065D08
Power Supply Schematic		34-017R06D08
Power Supply Schematic		34-020R03D08
Hexadecimal Display Panel Component Locator		35-519R02D03



2 Crescent Place, Oceanport, New Jersey 07757

QUICK REFERENCE INDEX

To aid in quickly locating a particular section, the index marks on the edge of this page are aligned with similar marks at the beginning of each section.

GENERAL DESCRIPTION



PROCESSOR



SELECTOR CHANNEL



AUTO LOADER



TEST AID



MICRO-PROGRAMS



DISPLAY PANEL



DRAWINGS



GENERAL DESCRIPTION



MODEL 7/16

GENERAL DESCRIPTION

1. INTRODUCTION

The Model 7/16 Processor combines advanced circuitry and packaging designs to give the user a price/performance optimized machine. The Processor is completely upward compatible with INTERDATA Model 3 and 4 Processor user instructions, interrupt handling, input/output formats and control sequencing. In addition, many of the powerful features of the INTERDATA Models 5, 70, 74 and 80 are included. Because of this compatibility, the Processor can use the wide range of existing software and peripheral devices.

The Processor offers a comprehensive set of 96 instructions making the system both easy to program and efficient to operate. Through multi-function instructions and direct core addressing, coding and debugging time is reduced to a minimum.

Memory is addressable to the eight-bit byte level. Memory is expandable from the basic 8,192 bytes to 65,536 bytes. All memory is directly addressable with the primary instructions, no paging or indirect addressing is required. Sixteen 16-bit General Registers can be used as Accumulators, fifteen of which can also be used as Index Registers. Register-to-Register instructions permit operations between any of the sixteen General Registers, eliminating redundant loads and stores.

The Processor also provides a flexible Input/Output system in addition to conventional means of programmed I/O. In the Automatic I/O Service mode, the Processor acknowledges all I/O interrupts and automatically performs much of the overhead prior to activating the Interrupt Service Routine.

A Direct Memory Access Channel can be added to a Processor memory system. This channel operates over the common Memory Bus, on a cycle stealing basis, through a Direct Memory Access Port which is built into the Processor. Two types of Direct Memory Access Channels can be used with the Model 7/16 System: The Selector Channel, which permits direct data transfer between any standard oriented INTERDATA device controller and memory; and the Direct Memory Access Channel custom designed by the user for special applications.

2. SCOPE

This specification is intended to enable the digital technician to understand the INTERDATA documentation system. Number Notation, the Part Numbering System, and the Drawing System are described. Illustrations are provided to help understand these systems. Other publications which may be of interest to Model 7/16 users are shown in Table 1.

A cross reference between INTERDATA part numbers and standard industry part numbers for the ICs and transistors found in the Model 7/16 may be found in Appendix 1.

TABLE 1. RELATED PUBLICATIONS

Title	Publication Number
Universal Clock Instruction Manual	29-265
Users Manual	29-261
Model 7/16 Maintenance Manual	29-364*
Multiplexor Bus Buffer Instruction Manual	29-267
8 Line Interrupt Module Instruction Manual	29-268

*This General Description is a part of 29-364.

3. BLOCK DIAGRAM

A Model 7/16 simplified block diagram is shown in Figure 1. The Model 7/16 is a 16-bit digital computer. The Processor logic is contained on two PC boards:

<u>Part No.</u>	<u>Description</u>	<u>Card File Position</u>
35-446	CPU-HI	6
35-520	CPU-LO	7

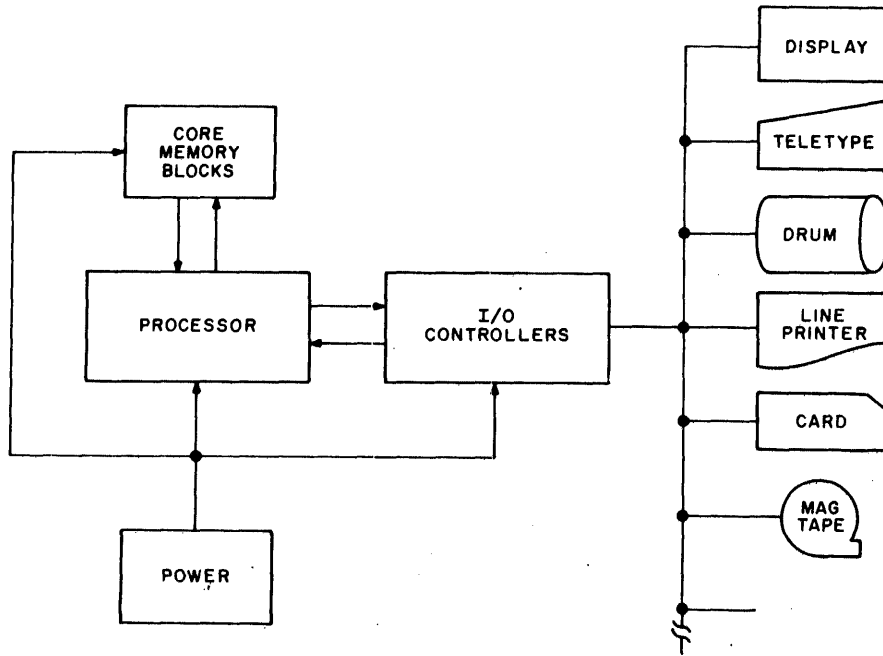

Figure 1. Model 7/16 Simplified Block Diagram

4. DOCUMENTATION

This section describes the style and conventions used with INTERDATA documentation.

4.1 Number Notation

The most common form of number notation used in INTERDATA documentation is hexadecimal notation. In this system, groups of four binary digits are represented by a single hexadecimal digit. Table 2 lists the hexadecimal characters employed.

TABLE 2. HEXADECIMAL NOTATION DATA

Binary	Decimal	Hexadecimal	Binary	Decimal	Hexadecimal	Binary	Decimal	Hexadecimal
0000	0	0	0110	6	6	1100	12	C
0001	1	1	0111	7	7	1101	13	D
0010	2	2	1000	8	8	1110	14	E
0011	3	3	1001	9	9	1111	15	F
0100	4	4	1010	10	A			
0101	5	5	1011	11	B			

To differentiate between decimal and hexadecimal numbers, hexadecimal numbers are preceded by the letter "X", and the number is enclosed in single quotation marks. Examples of hexadecimal numbers are: X'1234', X'2EC6', X'A340', X'EEFA', and X'10B9'.

This information is proprietary and is supplied by INTERDATA for the sole purpose of using and maintaining INTERDATA supplied equipment and shall not be used for any other purpose unless specifically authorized in writing.

4.2 Part Numbering System

INTERDATA parts, drawings, and publications employ a common numbering system. The part number and drawing numbers for drawings which describe the part are related. The publication number is also often related to the part number of the device or program described. Figure 2 shows the format used for INTERDATA part numbers. The fields are described in the following paragraphs.

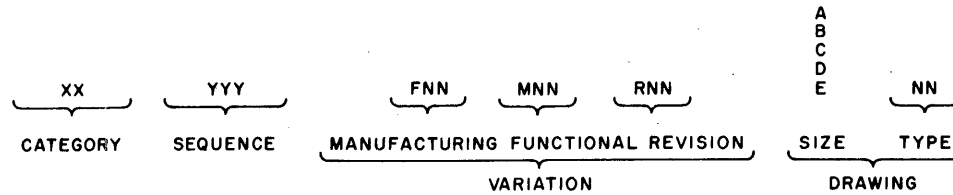

Figure 2. Part Number Format

4.2.1 Category Field. The two-digit Category number indicates the broad class or category to which a part belongs. Typical examples of category number assignments are:

01 - Basic Hardware Systems	13 - Panels
02 - Basic Hardware Expansions	17 - Wire and Cables
03 - Basic Software Systems	19 - Integrated Circuits
04 - Software Packages	20 - Transistors
05 - Micro-programs	27 - Peripheral Equipment
06 - Test Programs	29 - Manuals
07 - Subroutines of General Utility	34 - Power Supplies
10 - Spare Parts Packages	35 - Assembled Printed Circuit Boards
12 - Card File Assemblies	36 - Electro-Mechanical Devices

4.2.2 Sequence Field. The Sequence number identifies a particular item within the category. Sequence numbers are assigned serially, and have no other significance.

NOTE

The Sequence Field, like all other part number fields, may be lengthened as required. The field lengths shown on Figure 2 are minimum lengths (insignificant zeros must be added to maintain these minimums).

4.2.3 Functional Variation Field. The optional Functional Variation Field consists of the letter "F" followed by two digits. The F Field is used to distinguish between parts which are not necessarily electrically or mechanically equivalent, but which are described by the same set of drawings. For example, a power supply may be strapped internally to operate on either 110 vac or 220 vac. Except for this strap, all power supplies of this type are identical. The strapping option is easily described by a note on the assembly and test specification drawings. Therefore, this is a functional variation.

4.2.4 Manufacturing Variation Field. The optional Manufacturing Variation Field consists of the letter "M" followed by two digits.

NOTE

A part number must contain a Category number and a Sequence number. All other fields are optional.

The M Field is used to distinguish between parts which are electrically and mechanically equivalent (interchangeable), but which vary in method of manufacture. For example, if leads are welded instead of soldered on an assembly, the M Field changes.

An important exception to the meaning of the M Field exists for categories related to software. Here the M Field number, when used, indicates the form in which a particular program is presented. For example, define a program as a set of machine instructions. These same identical instructions may be presented on punched cards, paper tape, or magnetic tape; and for any of these they could be in symbolic form. Thus, there are many ways to represent the same identical program. These ways are identified by the M Field numbers as follows:

- M01 - Symbolic Punched Cards
- M02 - Relative Binary Punched Cards
- M03 - Absolute Binary Punched Cards
- M04 - Symbolic Magnetic Tape
- M05 - Relative Binary Magnetic Tape
- M06 - Absolute Binary Magnetic Tape
- M07 - Symbolic Punched Paper Tape
- M08 - Relative Binary Punched Paper Tape
- M09 - Absolute Binary Punched Paper Tape
- M10 - Bootstrap Binary Object Punched Paper Tape
- M11 - Read-Only-Memory (ROM) Absolute Binary Object Punched Paper Tape
- M12 - ROM Wiring and Test Set (ROMWATS) Wiring Punched Paper Tape
- M13 - ROMWATS Check Punched Paper Tape
- M14 - Eight-bit Paper Tape
- M15 - DROM Absolute Binary Object Punched Paper Tape
- M16 - Relocatable Non-Zoned Loader Format Paper Tape
- M17 - Absolute Non-Zoned Loader Format Paper Tape
- M18 - Non-Zoned Established Task Object Tape
- M19 - Source Cassette
- M20 - Object Cassette

4.2.5 Revision Field. The optional Revision Field consists of the letter "R" followed by two digits. The R Field is used to indicate minor electrical or mechanical changes to a part which do not change the part's original character. R Field changes often reflect improvements. A part with a revision level HIGHER than the one specified will work. A part with a revision level LOWER than specified should not be used.

4.2.6 Drawing Field. The optional Drawing Field consists of a letter from "A" to "E" followed by two digits. The letter indicates the size of the original drawing. The sizes for each letter are:

- A - 8½" X 11"
- B - 11" X 17"
- C - 17" X 22"
- D - 22" X 34"
- E - 34" X 44"

The two digits indicate the drawing type as follows:

- | | |
|-----------------------------|-----------------------------------|
| 01 - Parts List | 13 - Program Listing |
| 02 - Machine Details | 14 - Abstracts |
| 03 - Assembly Details | 15 - Program Description |
| 05 - Art Details | 16 - Operating Instructions |
| 06 - Wire Run List | 17 - Program Design Specification |
| 08 - Schematic | 18 - Flow Charts |
| 09 - Test Specification | 19 - Product Specification |
| 10 - Purchase Specification | 20 - Installation Specification |
| 11 - Bill of Material | 21 - Maintenance Specification |
| 12 - Information | 22 - Programming Specification |

4.2.7 Examples. The following list provides some examples of the part numbering system. The numbers were arbitrarily selected, and in most cases are fictitious.

- 35-060 The 60th printed-circuit board assigned a part number under this system.
- 35-060M01 A printed circuit board electrically and mechanically interchangeable with the 35-060, but differing in method of manufacture.
- 35-060F01 A printed-circuit board not electrically and mechanically interchangeable with the 35-060, but described by the same set of drawings.
- 35-060R01 A revised 35-060 printed-circuit board. Probably supersedes the 35-060.
- 35-060A01 The 8½ by 11 inch parts list for a 35-060.
- 35-060B08 The 11 by 17 inch schematic for a 35-060.
- 06-072 The 72nd utility program assigned a part number.
- 06-072A13 An 8½ by 11 inch listing of the 06-072 program.
- 06-072M03 An absolute binary deck of punched cards for the 06-072 program.
- 06-072A12 An 8½ by 11 inch information drawing on the 06-072 program. Probably a part of the program.
- 29-060 The 60th manual assigned a number under this system. Note that this number is not referenced in any way to the part number of equipment described in the manual.

4.3 Drawing System

This section describes the drawings provided with INTERDATA equipment. Note that drawings provided with peripheral devices and other purchased items may vary from the system described in this Section.

A digital system may be divided into a collection of functionally independent circuits such as memory, Processor, and I/O device controllers. These circuits may or may not be saleable units in their own right, but in the electrical sense they are essentially self contained and capable of performing their function with minimum dependence on other functional circuits in the system. Hence a functional circuit is treated as a building block. Each schematic contains a variety of information including type and location of discrete integrated circuits (IC's), pin connections, all interconnections within the schematic, connector pin numbers and connections to other schematics. Further, the schematics are drawn to reflect, in an orderly fashion, all logical operations performed by the circuits. Generally, symbols used on schematics conform to MIL-STD-806B.

Registers are named according to the following rules:

1. The register mnemonic name has a maximum of three letters, excluding 'I, O, Q, and Z'.
2. Each bit in the register is numbered, usually starting at 00 on the left, or most significant position, and continuing to N-1 on the right, where N is the number of bits in the register.
3. The 00 bit is the Most Significant Bit and the N-1 is the Least Significant Bit.

The IC's, mounted directly on the logic board, are represented on the schematic drawings by logic symbols. Each symbol contains the reference designation, device part number (category and sequence), and symbol mnemonic designation. Refer to Figure 3.

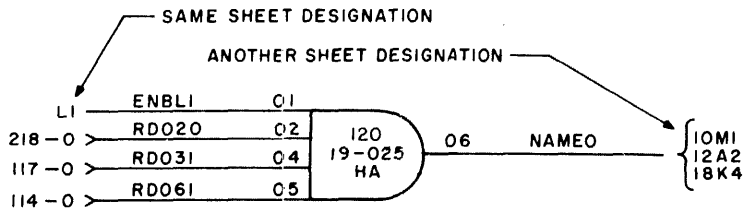

Figure 3. Example of a High Speed AND Gate

The designations, numbers, and references shown in Figure 3 are:

120 - This indicates the component location on the logic board. Figure 4 illustrates the method generally used to determine component location on a logic board. With the logic board oriented so that the header connectors (Conn 0 and Conn 1) are on the right, the components are numbered from left to right starting in the upper left corner. That is, the first IC in the upper left corner is 01 and the first capacitor is C1. Test points are lettered right to left from A-Y (omitting I, O, L, E).

19-025- The number 19 is the category number of ICs, and the 025 is the sequence number of the component.

HA - Indicates this component is a high speed AND gate. Some other common designations used are:

- | | | | | | |
|-----|---|---------------------------------|-----|---|---------------------------------------|
| B | - | Buffer | HP | - | High Speed Power Gate |
| G | - | Gate | HPO | - | High Speed Power Gate, Open Collector |
| GH | - | High Speed Gate | P | - | Power Gate |
| HB | - | High Speed Buffer | SA | - | Schottky AND Gate |
| HGO | - | High Speed Gate Open Collector | SG | - | Schottky Gate |
| HO | - | High Speed Gate, Open Collector | XOR | - | Exclusive OR |

L1 - This input lead is from area L1 on the same schematic sheet.

10M1, 12A2, 18K4 - Indicate outputs to another logic schematic sheet.

218-0, 117-0, 114-0 - Indicate inputs from Connector 0.

Note that the pin numbers (01, 02, 04, 05, and 06) correspond directly to the actual IC pin numbers.

Figure 4 also shows the locations of the header connectors (Conn 0 and Conn 1) and the cable connectors (Conn 2 and Conn 3). All logic boards always contain Header Connectors 0 and 1, however, any combination (either, both, or none) of cable connectors (Conn 2 and Conn 3) may be provided.

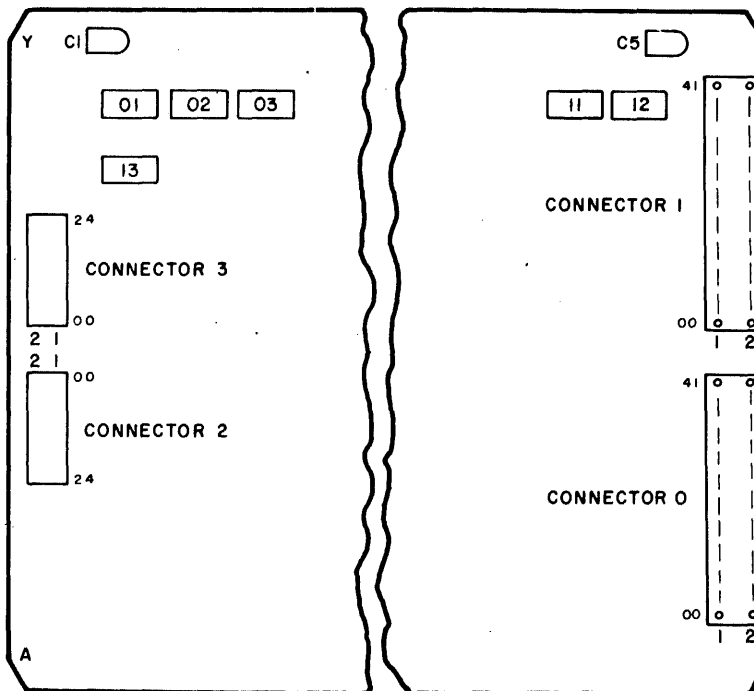

Figure 4. Example of a Logic Board Layout

This information is proprietary and is supplied by INTERDATA for the sole purpose of using and maintaining INTERDATA supplied equipment and shall not be used for any other purpose unless specifically authorized in writing.

Wherever possible, the immediate output of a flip-flop (1 or 0 side) will have a mnemonic name preceded by an 'F'. A flip-flop whose name is PSEL (Processor selected) will have an output mnemonic, on the 0 side, FPSELO (see Figure 5). This provides the digital technician with an indication when observing a mnemonic at the terminal end of a net, that the signal is the output of a flip-flop rather than a decoded function.

Clocked devices, flip-flops and counters in particular, are drawn in a manner which indicates information concerning their inputs. An input which has a circle adjacent to the pin designation implies a low active signal is required to perform the specified operation. In addition, an inverted V at the clock input shows that the device changes state on an edge. Thus, if no circle is present the chip is positive edge triggered. Refer to Figure 5 for examples.

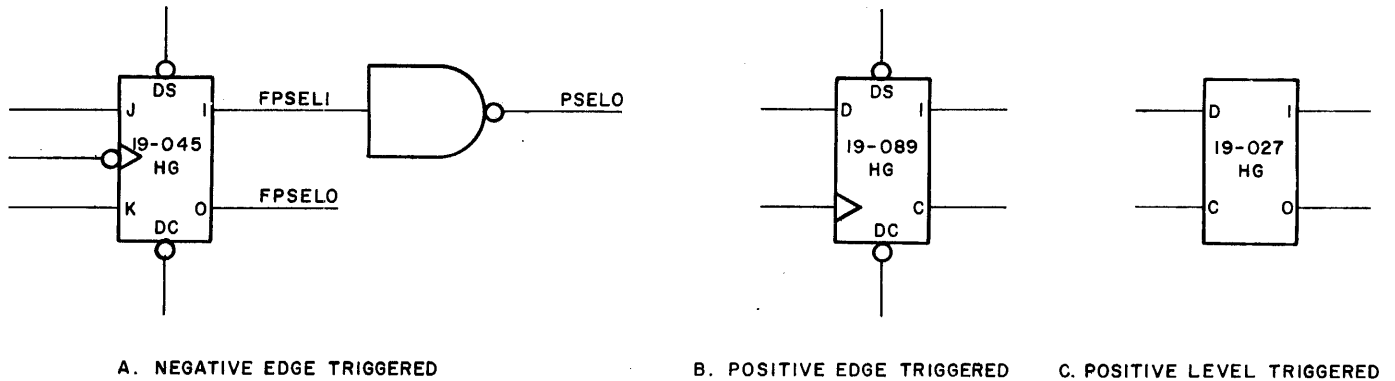

Figure 5. Examples of Clocked Devices

Figure 5 provides the pin numbering scheme for the header and cable connectors. Header connectors always have 2 rows of pins and 42 positions. Cable connectors always have 2 rows of pins but may vary in the number of positions. The number of positions may only vary in increments of five positions (10 contacts). For instance, if 24 positions are desired, five blocks of five positions each (25 positions) must be used.

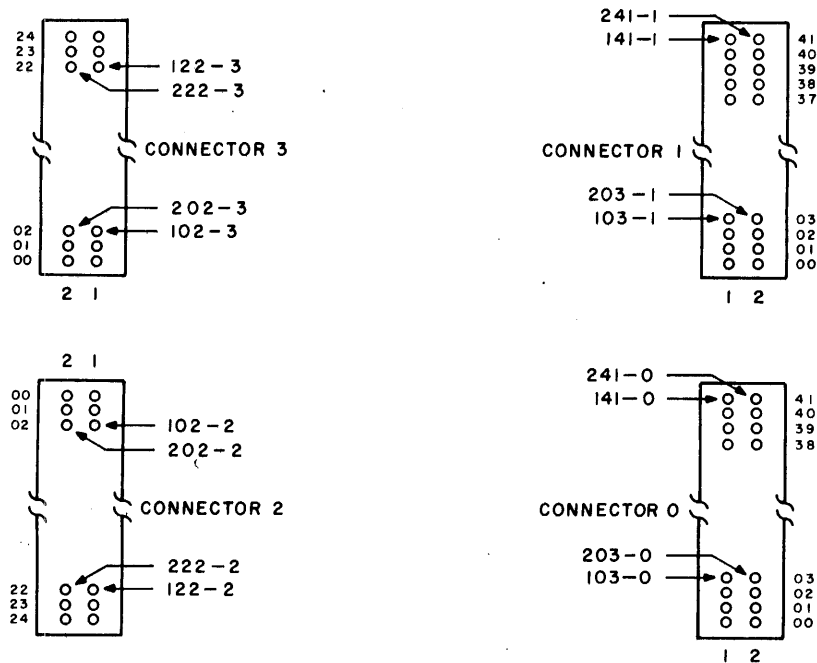

Figure 6. Connector Pin Numbering

This information is proprietary and is supplied by INTERDATA for the sole purpose of using and maintaining INTERDATA supplied equipment and shall not be used for any other purpose unless specifically authorized in writing.

A net is defined as an electrical connection between two or more points in a circuit. Ordinarily, a net has an originating end (usually a collector where the signal is generated) and one or more terminating ends. Often it is convenient to assign descriptive mnemonic names to nets as a way of identifying them on schematics. Whether a net is named or not is sometimes arbitrary. However, a net is always assigned a name if:

1. The net is contained on one drawing sheet but is not shown as a complete solid line on that sheet.
2. Part of the net appears on more than one sheet.
3. Part of the net connects with a different schematic.
4. Part of the net leaves a logic board.

If a net is named, the following rules are observed.

1. All mnemonic names are a maximum of six characters.
2. All decimal digits and upper case letters except the letters "I, O, Q, and Z" are permitted.
3. No other characters permitted.
4. Where possible, mnemonics are descriptive. However, it should be recognized that descriptive names are not always possible and a danger of misinterpreting a mnemonic exists.
5. Mnemonic names are not repeated within a schematic.
6. Every mnemonic is suffixed by a state indicator. This indicator consists of the digit "1" for the logically true state, or the digit "0" for the logically false state. For example, the set side of a flip-flop would have the "1" state indicator, while the reset side would have the "0" state indicator. The state indicator for a function changes each time that function is inverted. Thus, the state indicator permits assigning the same mnemonic to functions that are identical except for an inversion.
Logic '0' = .4VDC or less, Logic '1' = 2.4VDC or more.
7. When a logical function is inverted, an inversion indicator is added after the state indicator. This allows for functionally equivalent, but electrically different nets to have the same mnemonic name. For example, assume a signal NAME1. NAME1 may be inverted to produce NAME0. If NAME0 is then inverted, NAME1A is produced. NAME1 and NAME1A are functionally equivalent, but physically different nets.

Sometimes a net fans-out to many sheets in a schematic. It is also possible for a net to fan-out to sheets in different schematics. In these situations, the net is assigned a mnemonic name. The net is also "zoned" from sheet to sheet to allow for properly identifying the originating and terminating ends of the net. The originating end of a net is defined as the collector at which a signal is generated. All other points to which the net connects are called terminating ends. When a lead leaves a sheet at the originating end, it is zoned to each and every sheet on which the net reappears, by indicating first the page number, followed by the schematic number that contains the page. For example, assume that the gate shown on Figure 3 is on a schematic, sheet 20. The output, NAME0, appears on sheets 10, 12 and 18 of the schematic. Note that the schematic number is implied. When a net enters a sheet from another sheet, it is labeled with the same mnemonic name, and is zoned back to the originating end of the net only. Thus, on Figure 3, the ENBL1 may, however, have many other terminations in addition to the one shown. Generally then, when a net leaves the sheet where it originates, it is zoned to every other sheet where the net terminates, while the terminating end is zoned only to the originating sheet. Note that in the Model 7/16 schematics, signals are co-ordinated between sheets only when the sheets are related to the same board. When a signal leaves a board, the Back Panel Map must be used.

When a lead leaves a logic board, it usually does so through a logic board back panel connector pin. These connector pins must be shown on the schematic even if the complete net is shown on one drawing sheet. Only the connector pin number need be indicated under the pin symbol, since the connector number itself is implied by the logic board location number in the logic symbol or in the footnote. Thus, on Figure 3, RD061 enters the logic board on Pin 114 of Header Connector 0.

Figure 7 is a typical schematic sheet with call-outs illustrating many of the conventions described in this section.

The schematic drawings for the basic Digital System and some of the more common expansions are commonly included in the rear of the appropriate Digital System Maintenance Manual. Schematic drawings for other expansions are included with the expansion or with the publications that describe the expansion.

REVISIONS	
AREA NO:	ADDED
1002	RES.
P4	12-1-72
	155

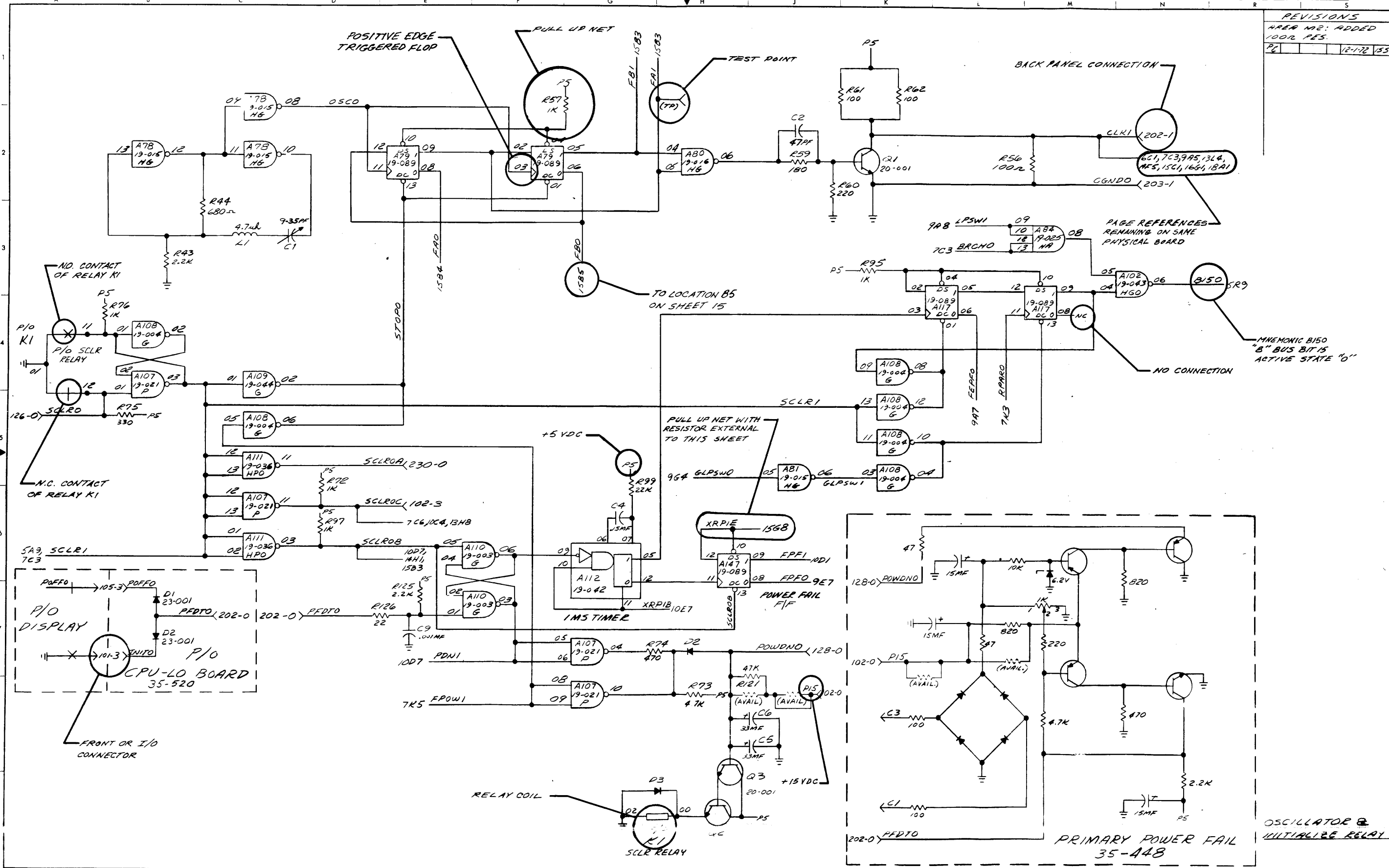

NOTES
 ALL APPARATUS ON THIS SHEET LOCATED
 ON CPU-MI BOARD 35-446 UNLESS OTHERWISE
 SPECIFIED

Figure 7. Functional Schematic Format Drawing

NAME	DATE	FILE	DESCRIPTION
E. MEGINLEY	12-9-72	35-446	FUNCTIONAL SCHEMATIC MODEL PROCESSOR
			35-058 008 2

APPENDIX 1

PART NUMBER CROSS REFERENCE TABLE

<u>INTERDATA Part Number</u>	<u>Type</u>	<u>JEDIC Number</u>
19-001	Dual 4 Input Nand DTL	15861
19-002	Triple 3 Input Nand DTL	15863
19-003	Quad 2 Input Nand DTL	15849N
19-004	Hex 1 Input Nand DTL	15837N
19-005	Dual Power Gate DOC	8633N
19-006	Dual Buffer DTL	1582N
19-007	Flip-Flop DTL	15848N
19-008	Gate Expander Dual 4 Input DTL	15833N
19-009	8 Bit Stack DTL	903059 (Fairchild)
19-010	Differential Compator LIN	72710L
19-012	Dual 4 Input Buffer TTL	74H40H
19-013	Quad 2 Input Nand DTL	15846
19-014	Dual J-K Flip-Flop DTL	158097N
19-015	Hex Inverter 1 Input	74H04H
19-016	Quad 2 Input TTL	74H00N
19-017	Triple 3 Input TTL	74H10N
19-018	Dual 4 Input TTL	74H20N
19-019	Single 8 Input TTL	MC3015 (Motorola)
19-020	Operational Amplifier LIN	MC1709C (Motorola)
19-021	Quad 2 Input Power DOC	15858N
19-022	Dual J-K Flip-Flop TTL	MC3061P (Motorola)
19-023	Selected Dual Buffer 19-006 with 20-30 nsec. delay DTL	15832N
19-024	Triple 3 Input AND TTL	74H11N
19-025	Dual 4 Input AND TTL	74H21N
19-026	2-2-2-3 Input AND-OR TTL	74H52

<u>INTERDATA Part Number</u>	<u>Type</u>	<u>JEDIC Number</u>
19-027	4 Bit Latch TTL	7475N
19-028	4 Bit Adder TTL	7483N
19-029	Quad Exclusive - OR TTL	7486N
19-030	4 Bit Shift Register TTL	7495N
19-031	One Shot TTL	7412N
19-032	1 out of 10 Decoder TOC	74145N 5445 7445
19-033	Sense Amplifier LIN	7524N
19-034	Retriggerable One Shot TTL	74122N
19-035	4 Bit Counter TTL	74193N
19-036	Quad 2 Input Open Collector TTL	7438N
19-037	High Performance Operational Amp	7748393 (Fairchild)
19-038	Dual 4 line to 1 line Mux TTL	74153
19-039	4 Bit ALU TTL	74181
19-040	Look Ahead Carry TTL	74182
19-041	4 x 4 Register Stack TTL	74170
19-042	Dual Retriggerable One Shot TTL	74123N
19-043	Quad 2 Input Open Collector TTI	74H01N
19-044	Hex-Inverter Open Collector TTL	74H05N
19-045	Dual J-K Flip-Flop TTL	74H106
19-046	Quad RS-232C Line Driver	MC1488L (Motorola)
19-047	Quad RS-232C Line Receiver	MC1489AL (Motorola)
19-048	8 Bit Shifter	74198N
19-050	8 Input Nand TTL	74H30
19-051	1024 Bit PROM TTL	74187 (Fairchild)
19-055	Quad 2 Input Nand STTL	74S00
19-056	Quad 2 Input Nand Open Collector STTL	74S03
19-057	Hex 1 Input Inverter STTL	74S04
19-058	Triple 3 Input Nand STTL	74S10
19-059	Triple 3 Input AND STTL	74S11
19-060	Dual 4 Input Nand STTL	74S20

<u>INTERDATA Part Number</u>	<u>Type</u>	<u>JEDIC Number</u>
19-061	Dual 4 Input Buffer STTL	74S40
19-062	2-2-3-4 Input AND-OR Inverter STTL	74S64
19-063	Dual D Edge Triggered Flip-Flop STTL	74S74
19-064	Dual J-K Flip-Flop STTL	74S112
19-065	Quad 2:1 Max Non-inverting STTL	74S157
19-066	Quad 2:1 Mux Inverting STTL	74S158
19-067	4 Bit ALU STTL	74S181
19-068	Carry Look Ahead STTL	74S182
19-069	8 line to 1 line Mux STTL	74151
19-070	4 Bit Synchronous Counter TTL	74161
19-071	Quad D Edge Triggered Flip-Flop	74175
19-072	4 Bit Left/Right Shift Register TTL	74194
19-073	Dual 4:1 Mux Tri-State TTL	8214 (National)
19-074	8 Bit Priority Encoder TTL	9318 (Fairchild)
19-075	16 x 4 Register Stack TTL	3101A (Intel)
19-076	1024 Bit Memory MOS	TM54062
19-077	256 Bit Memory TTL	6531 (Monolithic Memories)
19-078	Dual 4 Input Nand-OC	74S22
19-080	High-Speed PROM	82S29 (Signetics)
19-081	Univ. Asynchronous Receiver/Transmitters	TR1042A (Western Digital)
19-082	2-2-3-4 Input AND-OR Invert Open Collector STTL	74S65
19-083	9 Bit Parity Generator/Checker STTL	82S62 (Signetics)
19-085	Monolithic Timing Circuit	MC1555 (Motorola) NE555V (Signetics)
19-086	741 C DIP Operational Amplifier	U6A7741393 (Fairchild)
19-087	747 DIP Operational Amplifier	U7A774 (Fairchild)
19-088	737 C DIP Operational Amplifier	U6A773393 (Fairchild)
19-089	Dual D Edge Triggered Flip-Flop	74H74
19-090	High Speed (710) Differential Comparator DIP	U6A771093 (Fairchild)
19-091	Retriggerable Single One Shot	9600 (Fairchild)

<u>INTERDATA Part Number</u>	<u>Type</u>	<u>JEDIC Number</u>
19-092	Negative Voltages Regulator	MC1463R (Motorola)
19-093	Positive Voltages Regulator	MC1469R (Motorola)
19-094	Voltage Regulator	U6A7723393 (Fairchild) MC1723CL (Motorola)
19-095	Linear Positive Voltage Regulator	U9H7805393 (Fairchild)
19-096	First In-First Out Serial Memory 64 Word 4 Bit	3341 (Fairchild)
19-097	Amplifier	LH0002H (National)
19-098	Quad 2:1 Multiplexor Non-Inverting	74157
19-099	Dual Sense Amplifier	75234N
19-100	Driver	75452N
19-101	4-2 Input Buffer	7437N
19-102	6-1 Input Buffer OC	7407N
19-103	1 out of 10 Decoder	7442N
19-104	Current Switch	75325N
20-001	Transistor NPN High Speed Switch	2N3646
20-002	Transistor PNP 500 MA	MPS6534 (Motorola)
20-003	Transistor	2N3902
20-004	Transistor NPN	2N5189
20-006	Transistor NPN 15 Amps 100W T03 case	2N3055 (RCA)
20-007	Transistor NPN 3 Amps	TIP31A
20-008	Transistor PNP 3 Amps	TIP32A
20-009	Transistor Triac 2 Amps 100V	A03001 (Electronic Control Corp).
20-010	Transistor NPN 500 MA Code Driver	2N5845
20-011	Transistor Photo	2N5777
20-012	Transistor PNP High Current Switch	2N2907
20-013	Transistor NPN	2N3303
20-014	Transistor NPN	2N4238
20-015	Transistor PNP	2N4235
20-016	Transistor PNP	2N3740
20-017	Transistor NPN	2N3766

<u>INTERDATA Part Number</u>	<u>Type</u>	<u>JEDIC Number</u>
20-018	Transistor, Power Silicon NPN	2N3054
20-019	Transistor NPN Fast PWR Switch	2N6308 (Motorola)
20-020	Transistor Switching 1 Amp T05 can	2N3725
20-021	Transistor NPN Silicon	MPS3646 (Motorola)
20-022	Transistor NPN	1N1711
20-023	Transistor PNP	2N2905A
20-024	Transistor Switch	2N3776
21-025F01	1K ohm-15 to Common DIP	898-1-1K ohm (Beckman)
21-025F02	470 ohm-15 to Common DIP	898-1-470 ohm (Beckman)
21-025F03	330 ohm-15 to Common DIP	898-1-330 ohm (Beckman)
23-001	Diode High Speed-High Current	1N914
23-002	Diode 5.1 V Zener	1M5.1ZS5 (Motorola)
23-003	Diode 10V Zener	1M10ZS5 (Motorola)
23-004	Diode 6.2 V Zener	1M6.2ZS5 (Motorola)
23-007	Diode Mot Bridge	MDA962-2 (Motorola)
23-008	Diode Int. Rectifier	40HF-5R
23-009	Diode	1N4735
23-010	Diode Int. Rectifier	S1Y1P
23-011	Diode Rectifier	2N681
23-012	Diode Thermister	KA31J1 (Fenwall)
23-013	Diode 9.4V	1N2163
23-014	Diode	1N3880
23-015	Diode	1N3889
23-016	Diode Bridge Rectifier	VS448 (Varo)
23-017	Diode	1N2070
23-018	Diode 18 V Zener	1N4746A
23-019	Diode	1N3615
23-020	Diode 8.2V Zener	1N756A
23-021	Diode 9.1 V Zener	1N757A
23-022	Diode 3.3V Zener	1N746A
23-023	Diode Bridge Rectifier	KBH2506 (General Instrument)

<u>INTERDATA Part Number</u>	<u>Type</u>	<u>JEDIC Number</u>
23-024	Diode, Power Fast Rec. 30 Amps.	1N3909
23-025	Diode, Power Fast Rec. 3 Amps.	A115A (General Electric)
23-026	Triac 600V 30 Amps	2N6162
23-027	Diac 32V	1N5761
23-028	Power SCR Thyristor	2N4441
23-029	Diode	1N4607
23-030	Diode	1N4156
23-031	Diode 6.6 V Zener	1N4736
23-032	Diode 8.8 V Zener	1N4739
23-033	16 Diode Array	45190 (Litton)
30-018	100 nsec. Delay Line 10 taps	30-018 (Princeton Advanced Eng.)
30-019	50 nsec. Delay Line 10 taps	30-018 (Princeton Advanced Eng.)

PROCESSOR



M71-SERIES

MODEL 7/16

INSTALLATION SPECIFICATION

1. INTRODUCTION

The INTERDATA Model 7/16 Digital System features a highly modular structure which permits configurations to suit the user's exact needs. It provides the means for convenient expansion as the user's requirements grow. This document describes the Processor and System Expansion Chassis, Power Supply Mounting, Filler and Display Panel mounting, and the interconnecting cables. Printed circuit boards are discussed with respect to cabling and location only. Circuit descriptions of these boards are provided in the appropriate maintenance or instruction manuals. Note that the following discussion assumes that the equipment is mounted in standard INTERDATA cabinets. In addition, this specification covers the installation of the Basic Switch Control Panel and Model 7/16 Memory.

2. MECHANICAL COMPONENTS

This section is intended to familiarize the reader with the mechanical components that are discussed here (i.e., Cabinet Uprights, Chassis Support Rails, Filler Panels). Figures 4 through 8 provide the dimensions and mounting configurations for the Rack, Chassis Support Rails, and Filler/Display Panels. Note in Figure 8, that while 3 1/4", 7", and 10 1/2" Filler Panels and the Display Panel mount the same way (via retaining brackets), the smaller 1 3/4" Filler Panel mounts with spring clips.

3. POWER SUPPLY MOUNTING

The Power Supply mounts in the rear of the cabinet, behind the Processor or Expansion Chassis. It is attached to the right mounting upright (looking from rear). Either of two Power Supplies may be supplied with the Model 7/16 System.

WARNING

Before hinging out the power supplies, the rack levelling feet should be lowered. After the levellers are in contact with the floor surface, up to three power supplies may be hinged out at one time.

34-017 and 34-020 Power Supplies. The 34-017 and 34-020 supplies attach to the mounting upright via four 10-32 X 1/2 Lg PHPS screws. See Figure 9.

When either power supply is in the installed operating position, it is secured to the left rear upright by two 10-32 screws. The power supply cable connects to terminal lugs at the right rear (looking from rear) of its respective Processor or Expansion Chassis via faston lugs and a connector for fan AC power. Refer to Figure 10. There is adequate slack provided in the cable to allow the Power Supply to hinge out freely. In order to prevent the cable from being pinched between the Power Supply and the Chassis Support Rails, a service loop is required. A maximum of five power supplies may be mounted in one rack.

3.1 New Power Supply

INTERDATA now has several new Power Supplies available for use with its line of digital systems. These supplies are manufactured by INTERDATA, and may replace those previously used. This section provides information on these new supplies, and on several associated changes to INTERDATA systems.

There were three power supplies available:

Model Number 34-012 Power Supply. The 34-012 is the original power supply. This unit has a transformer that always supplies 115V for fan power at both 115V and 230V strappings. It supplies chassis fan power with a male connector (now discontinued).

Model Number 34-017 Power Supply. The 34-017 is the 25 ampere version of the INTERDATA supply. This unit supplies 115V or 230V depending on AC source for fan power. Chassis fan power is supplied with a U.L. approved female connector.

Model Number 34-020 Power Supply. The 34-020 is the 50 ampere version of the INTERDATA supply. The fan power consideration and the output connector are the same as for the 34-017 unit.

Two types of fan jumper cables are provided. Cable 17-181 is wired with two male connectors, while cable 17-287 is wired with one male and one female connector.

Because the newer power supplies supply line power for the fans, it is necessary to re-wire the fans in the chassis to operate with 230VAC. The New Chassis provides an AC power switch for switching fan power to either voltage. When using the newer supplies (34-017 or 34-020) with the former chassis, only 115V operation is possible, unless the chassis is modified.

3.2 Configuration Data

The 34-012 may be replaced in the following ways.

25 AMP	34-012 (1 each)	Replaced by 34-017 (1 each)
50 AMP	34-012 (2 each)	Replaced by 34-020 (1 each)

The following paragraphs outline the factors involved in using different combinations of chassis, power supplies, and cables.

1. The 34-012 with the "Former Chassis".

This unit is used for 115/230V operation. The "Former Chassis" (1 or 2 fan) is wired for 115V operation and equipped with two female connectors for fan power. Refer to Figure 1.

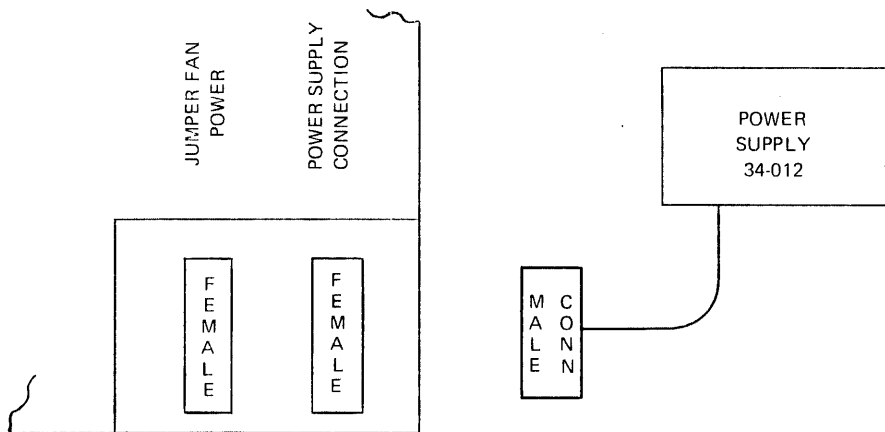

Figure 1. Former Chassis

2. The 34-012 Power Supply with a "New Chassis".

This unit is used for 115/230V operation, however, the 115/230V fan switch on the "new chassis" must remain in the 115V position for 115V or 230V operation. If two or more "new chassis" are powered, standard fan jumper cable, 17-181, must be replaced by cable 17-287.

NOTE

The "new chassis" (1 or 2 fan) is wired for 115/230V fan operation and equipped with one male and one female connector for fan power. See Figure 2.

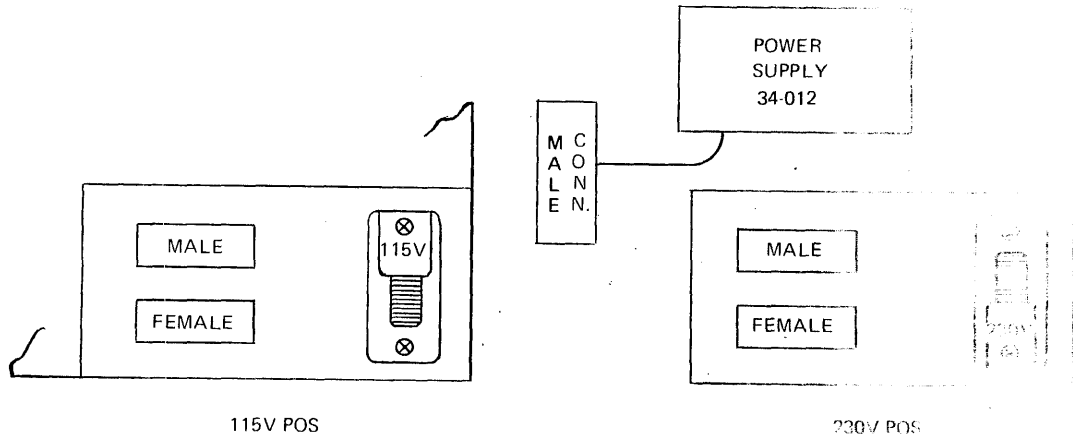

Figure 2. New Chassis

3. The 34-017 Power Supply with a "New Chassis".

This unit is used for 115/230V operation, however, the 115/230V fan switch on the chassis must be matched with the 115V or 230V strapping in the Power Supply.

4. The 34-017 Power Supply with a "Former Chassis".

This unit is used for 115V operation (ONLY) using cable 17-181.

NOTE

The "former chassis" must be rewired for 230V operation. Kits 39-020F01 (1 fan) and 39-020F02 (2 fans) must be used to convert a chassis wired for 115V to 115/230V fan operation.

3.3 Exhaust Fans

New exhaust fan plates are equipped with a switch to provide either 115 or 230VAC operation. See Figure 3.

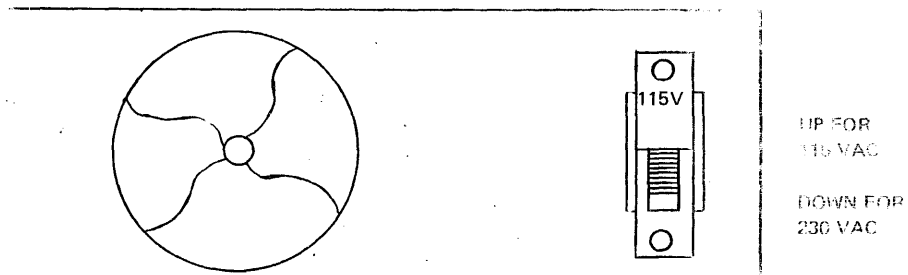

Figure 3. Fan Switch Setting

This information is proprietary and is supplied by INTERDATA for the sole purpose of using and maintaining INTERDATA supplied equipment and shall not be used for any other purpose unless specifically authorized in writing.

WARNING

All AC fan connectors on Power Supplies which are not connected to mating receptacles **MUST** remain covered or shorting may occur. See Figure 4.

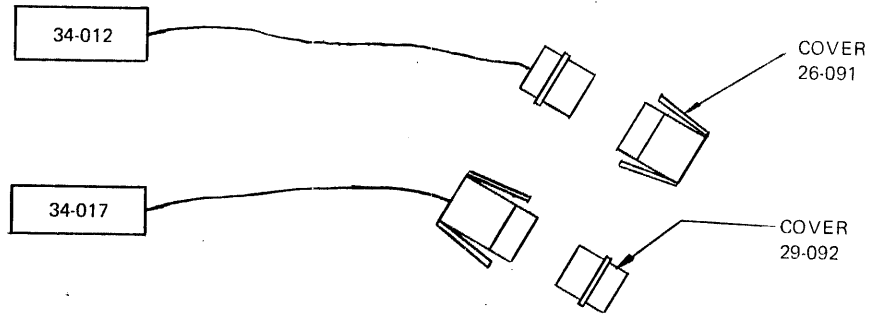

Figure 4. Fan Connector Caps

4. PROCESSOR AND EXPANSION CHASSIS MOUNTING

Two Expansion Chassis (10 inch and 15 inch) are available for expanding the Model 7/16 Digital System. The (15 inch) Expansion Chassis has the same over-all dimensions as the Processor Chassis. See Section 8 on Configuration.

The Expansion or Processor Chassis slides into the rack on the two Chassis support rails (see Figures 6 and 7) from the front of the rack.

CAUTION

No chassis should be mounted in cantilever fashion.
Chassis support rails **MUST** be used. If a rack cabinet other than an INTERDATA cabinet is used, consult rack manufacturer for proper support rails.

The chassis support rails are fastened to the mounting uprights at the front and rear of the rack. Slots are provided in the rails to allow vertical adjustment. The Expansion or Processor Chassis are screwed in place at the mounting uprights in front of the rack. All Expansion Chassis mount below the Processor Chassis. Expansion Chassis cabling is discussed later in this document. Figure 11 shows Expansion Chassis location with respect to the filler panel and power supply.

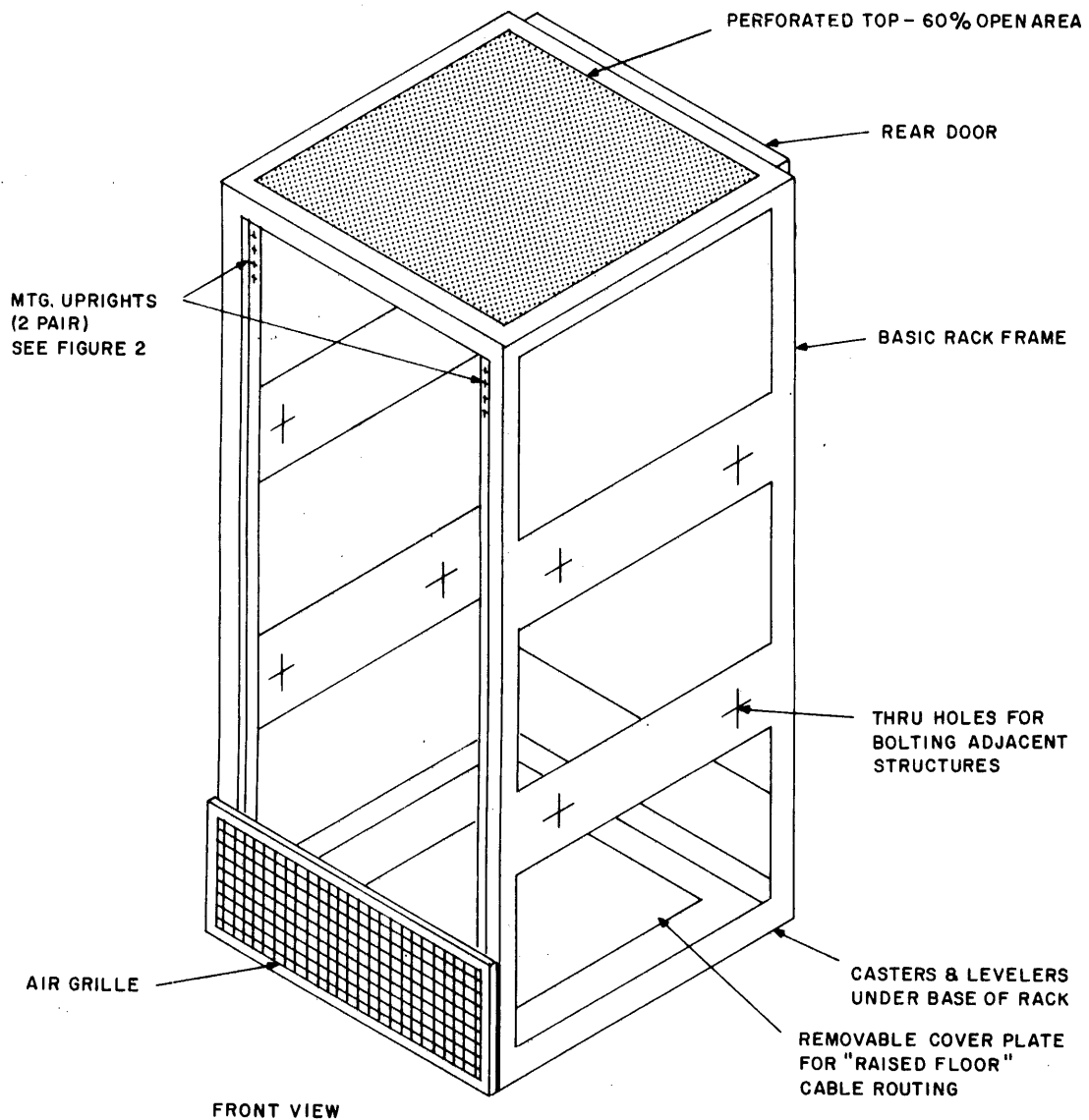

Figure 5. Basic Cabinet

This information is proprietary and is supplied by INTERDATA for the sole purpose of using and maintaining INTERDATA supplied equipment and shall not be used for any other purpose unless specifically authorized in writing.

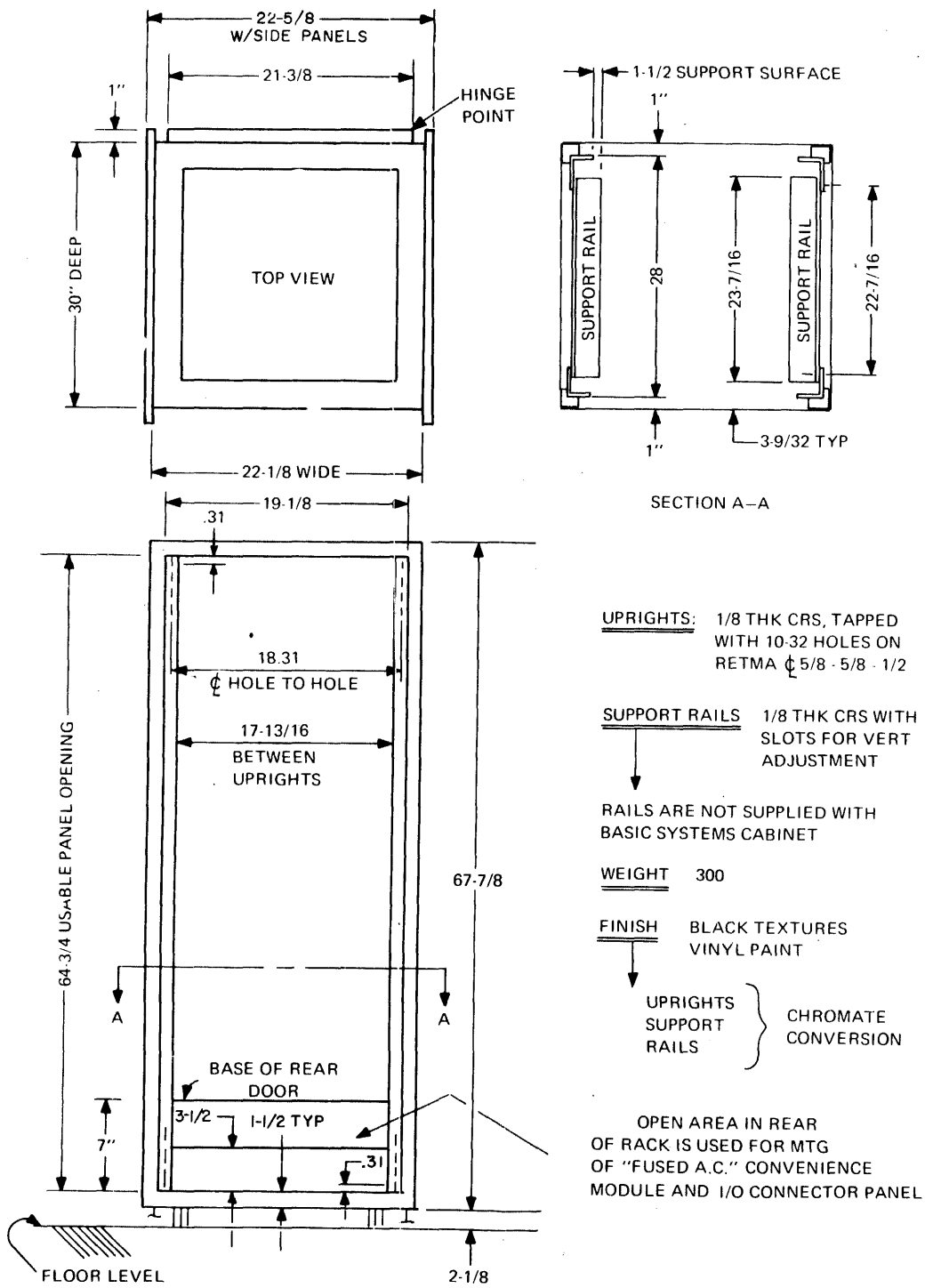

Figure 6. Basic Cabinet Physical Dimensions

This information is proprietary and is supplied by INTERDATA for the sole purpose of using and maintaining INTERDATA supplied equipment and shall not be used for any other purpose unless specifically authorized in writing.

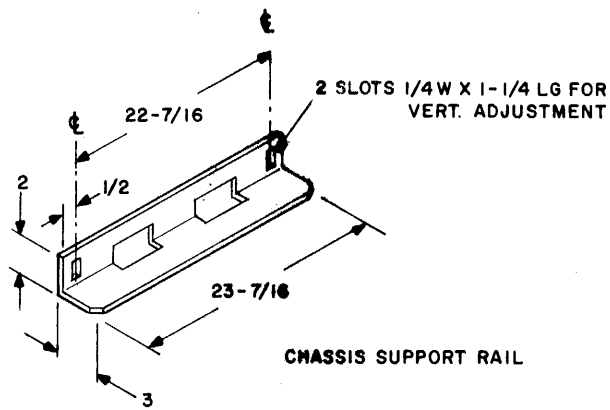

Figure 7. Chassis Support Rail

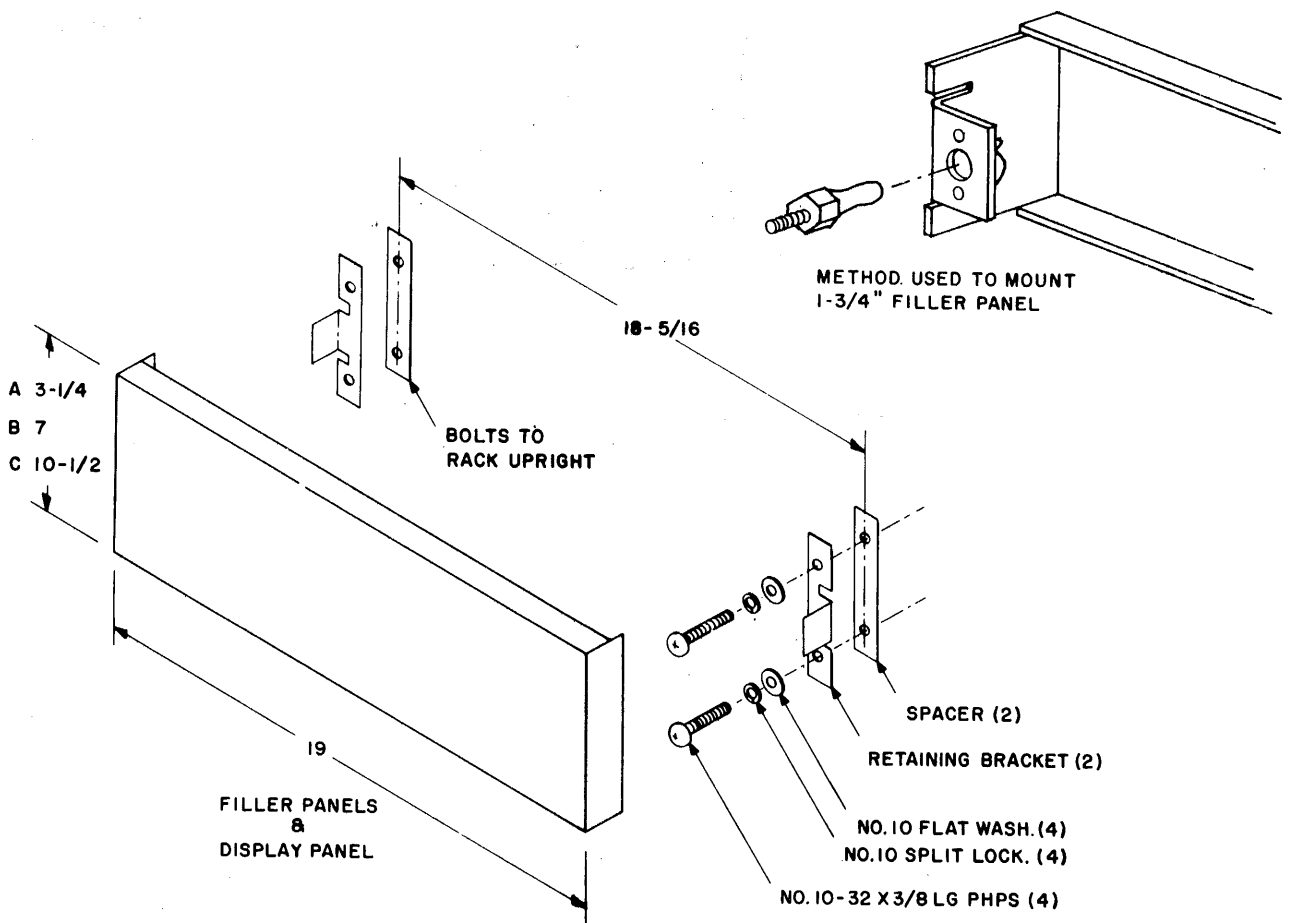

Figure 8. Typical Mounting Configuration for Display and Filler Panels

This information is proprietary and is supplied by INTERDATA for the sole purpose of using and maintaining INTERDATA supplied equipment and shall not be used for any other purpose unless specifically authorized in writing.

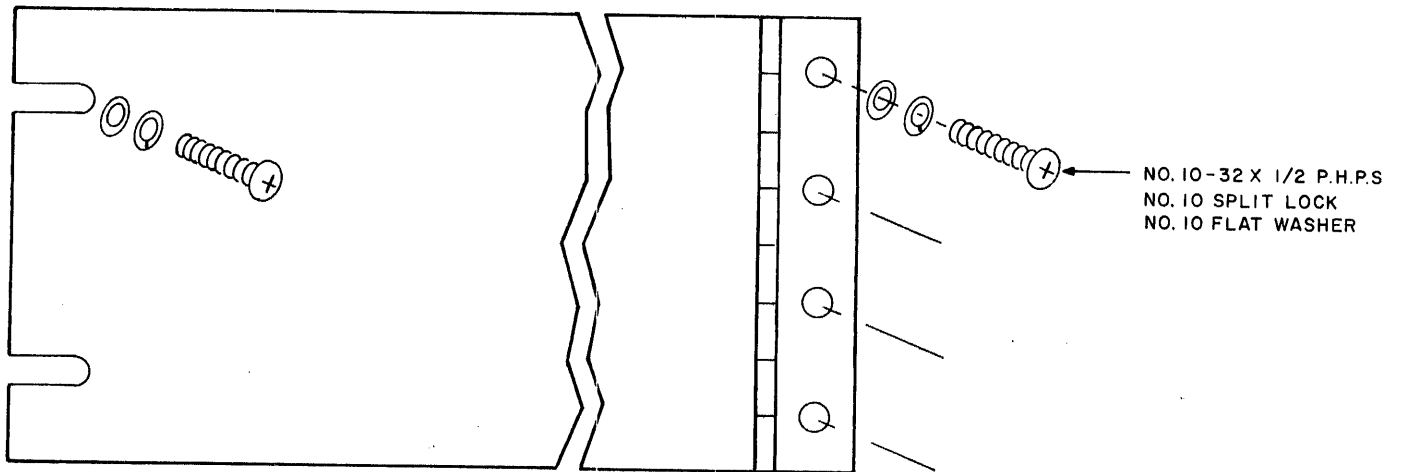

Figure 9. 34-017 and 34-020 Power Supply Mounting

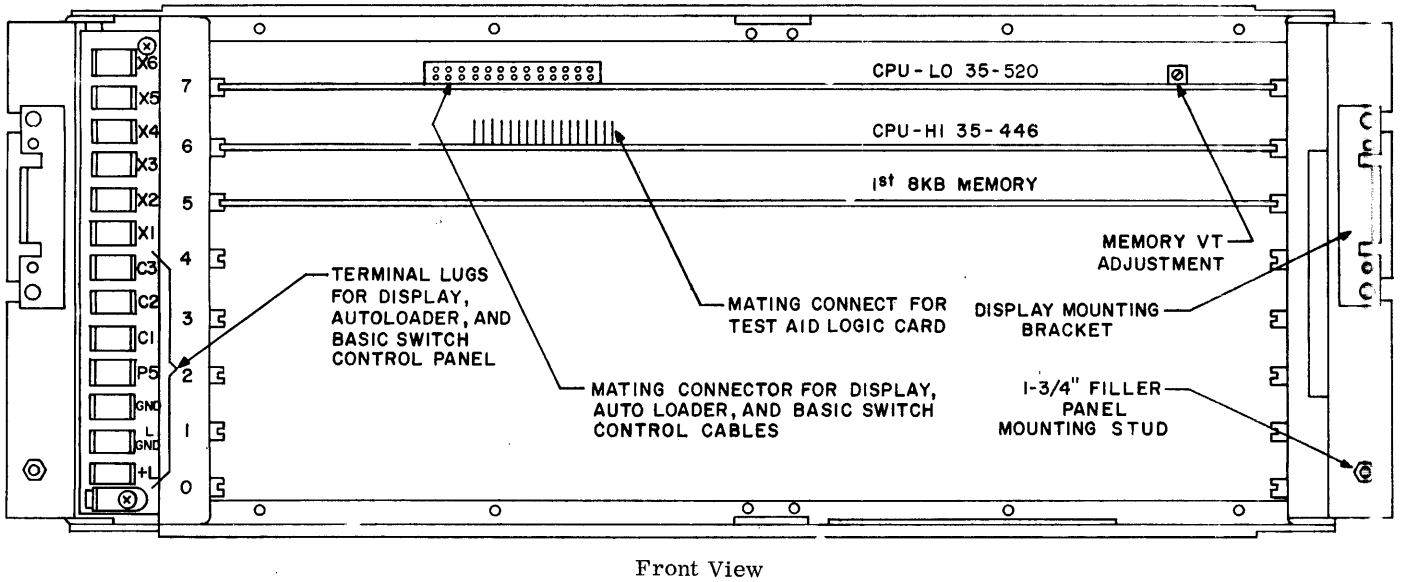
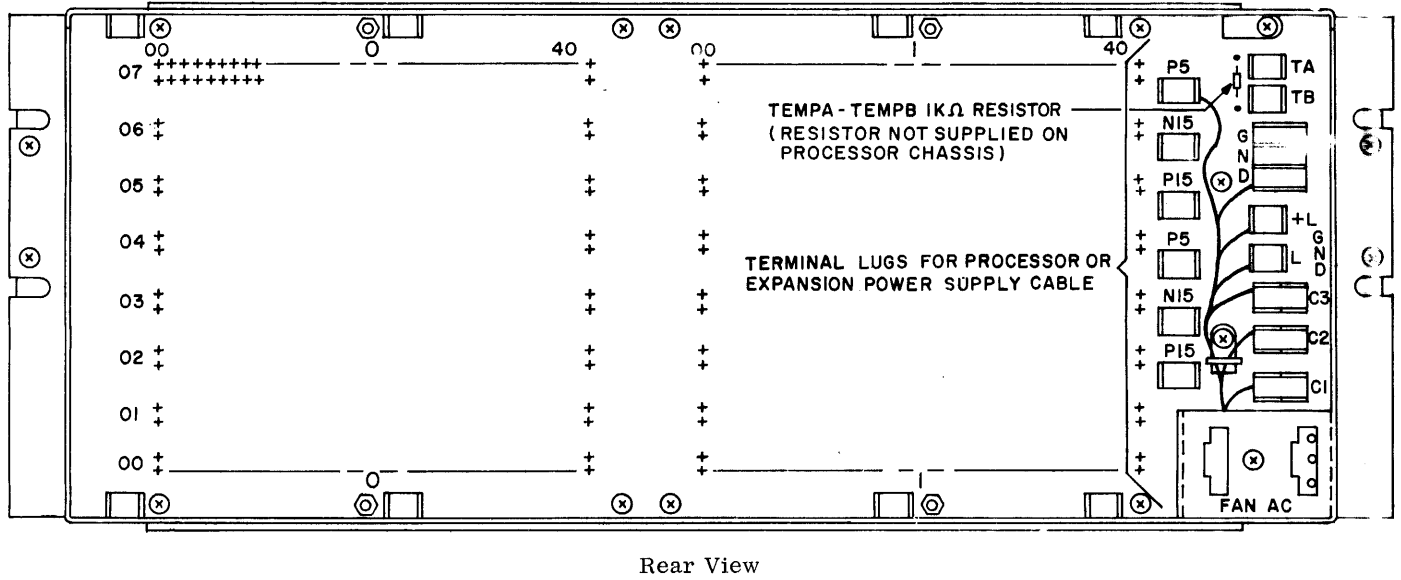
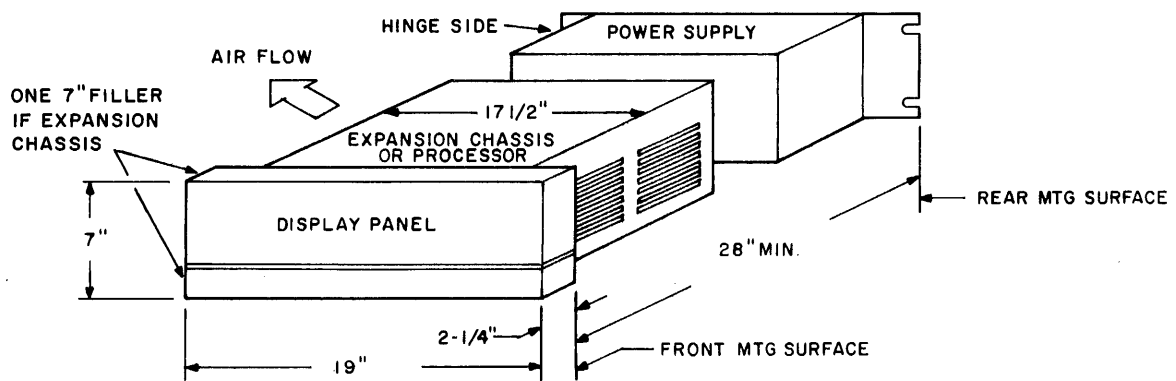

Figure 10. View of the Processor and 15 Inch Expansion Chassis



This information is proprietary and is supplied by INTERDATA for the sole purpose of using and maintaining INTERDATA supplied equipment and shall not be used for any other purpose unless specifically authorized in writing.

4.1 15 Inch Expansion Chassis

The 15 inch Expansion Chassis contains eight universal expansion slots which can accept combinations of memory modules, single board peripheral controllers, system modules, Selector Channel, or user designed interfaces. Included with this chassis are the cooling fans and interconnecting cables. The chassis may be ordered with or without a power supply.

4.1.1 7 and 10 Inch Boards in a 15 Inch Chassis. A 10 inch I/O Controller (provided it does not use Connector 1) may be inserted in a 15 inch chassis via the 02-234 I/O Adapter Kit (see Figure 8). One or two 7 inch boards (half boards) may be inserted into a 15" chassis via the 16-398 Half Board Adapter Kit (see Figure 13). The Half Board Adapter Kit may hold two active 7" boards or one active and one blank 7" board, depending on requirements. No wiring takes place between the boards and the adapters. The adapters are designed such that the connectors on the boards plug directly into the Expansion Chassis.

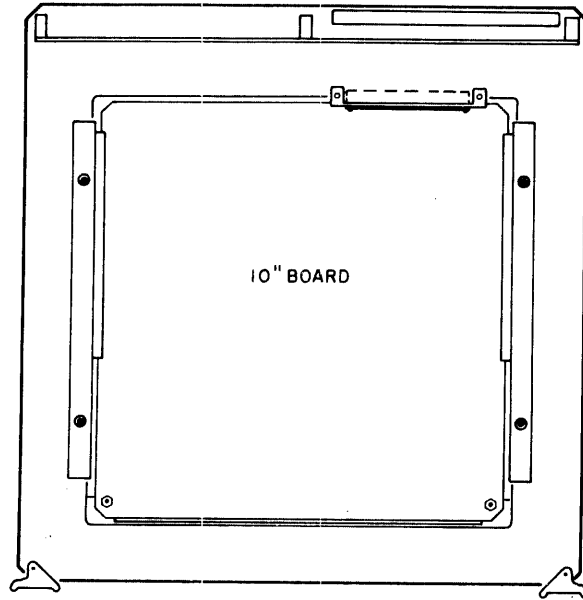

Figure 12. 02-234 I/O Adapter (Top View)

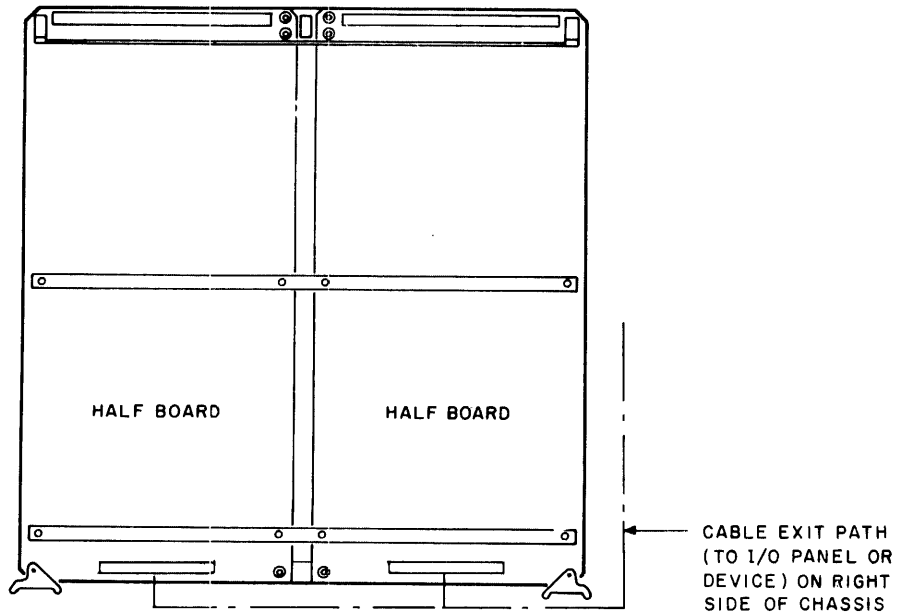

Figure 13. 16-398 Half Board Adapter

This information is proprietary and is supplied by INTERDATA for the sole purpose of using and maintaining INTERDATA supplied equipment and shall not be used for any other purpose unless specifically authorized in writing.

4.2 10 Inch Expansion Chassis

The 10 inch Expansion Chassis contains six 10 inch I/O expansion slots which can accept any combination of up to six 10 inch wire-wrap or copper peripheral controllers, systems, modules, or user designed interfaces. Included with the chassis are the cooling fans and system interconnecting cables. The Power Supply is separate.

5. DISPLAY PANEL INSTALLATION

The optional Model 7/16 Hexadecimal Display Panel is electrically tied to the Processor via one connector and seven Faston lugs. The connector is installed on Connector 3 of the CPU-LO board (35-520) and the seven terminal lugs mate into a terminal strip on the left side of the Processor Chassis. The terminal lugs are identified at the Faston connector and are mated to their corresponding terminal pin (C1, C2, etc.) on the chassis. See Figure 10.

The Hexadecimal Display Panel is physically mounted to the brackets provided on the Processor Chassis. The 1 3/4 inch Filler Panel is mounted directly below the Hexadecimal Display Panel on this same chassis. Refer to Figure 10.

6. BASIC SWITCH CONTROL PANEL INSTALLATION

The Basic Switch Control Panel is connected to the Processor in the same manner as the Hexadecimal Display Panel discussed above. Only two Faston connectors are provided with this assembly, but their installation is the same.

The Panel on which the switches are installed may be mounted to the chassis uprights with standard 10-32 hardware. This panel is intended to mount behind a door or filler panel to prevent easy accessibility when the system is running. The Hexadecimal Display Panel option, the Automatic Loader option, and the Basic Switch Control Panel option may not be installed together on the same Processor.

7. MEMORY INSTALLATION AND EXPANSION

The first Model 7/16 memory module must be installed in Slot 5 of the Processor card file. Further memory expansions are installed in adjacent slots in this chassis. Slots 0 and 1 of the Processor Chassis must not be used for memory if the system includes more than six-8KB memory modules. These slots may be used for I/O controllers or Slot 0 may be used for a Selector Channel. For systems with more than six-8KB memory modules the fifth memory module must be installed in Slot 7 of the first expansion chassis. This is necessary to insure proper temperature tracking characteristics for the memory voltages from the Expansion Chassis Power Supply. The additional modules are then installed in one of the slots prewired to accept that module. Refer to the Configuration Data Sheet, Figure 14, for module assignments. When memory is installed in an expansion chassis, the 1K ohm resistor between TEMA and TEMA at the back panel must be removed. If for any reason the memory module installed in Slot 7 is removed (see Figure 10), the resistor must be replaced before applying power. A strap option located on the Model 7/16 CPU-HI (35-446) is used to indicate to the Processor whether the system has parity in non-parity memories. See 35-446E03 component locator. Strap M to N for non-parity and Strap L to M for parity memory.

NOTE

Parity and non-parity memories may not be mixed in a system.

8. PRIMARY POWER FAIL/AUTO-RESTART INSTALLATION

Install the logic card (35-448) for the Primary Power Fail/Auto-Restart option on the back panel of the CPU chassis at Slot 6, Connector 0 with the apparatus side up. The cables (17-182F01 and 17-182F02), which supply 12 VAC to the logic card, connect between C1 on the logic card and C1 on the back panel and C3 on the logic card and C3 on the back panel as indicated on the cables. On the CPU-HI board (35-446) remove the jumper between J and K and add a jumper between H and K. (These letters refer to designations on the component locator, 35-446E03 only.)

9. CONFIGURATION

9.1 System Expansion Chassis

When configuring a multi-chassis system there are four rules that must be followed:

1. The system Expansion Chassis must be mounted below the basic Processor Chassis.
2. All chassis must be contiguous.
3. All 15 inch system expansion chassis must be mounted above any 10 inch system Expansion Chassis.
4. Multiboard peripheral device controllers (on 10 inch circuit boards) can only be used in the 10 inch system Expansion Chassis.

9.2 Circuit Board Distribution

Model 7/16 Digital Systems may be configured in a variety of ways. However, the following factors must be considered when determining circuit board distribution within the basic Processor and the system Expansion Chassis. See Figure 14.

1. The Selector Channel can be placed in Slot 0 or Slot 2 of the Processor Chassis, or Slots 6, 4, 2, or 0 of the system Expansion Chassis.
2. All slots on Connector 1 below the position where the SELCH is inserted become SELCH Bus slots. (This only applies within the chassis containing the SELCH.) The SELCH Bus extends down the left side connectors (front view). Note that all device controllers on 10" adapter boards connect to the Multiplexor Bus from the right side connectors (front view). Therefore, these device controllers may be inserted in vacant SELCH Bus slots, but will not be on the SELCH Bus. This also applies to all 7" boards on adapters, installed on the right side.
3. The SELCH Bus can be extended by cable to any even numbered slot in an I/O chassis adjacent to the chassis containing the SELCH controller.
4. All device addresses are hard-wired on the device controller cards, (device addresses may be changed at option) so that the distribution of I/O device controllers in the chassis normally need only be considered as a matter of priority in the RACK0/TACK0 "daisy-chain" and convenience.
5. Slots 5, 4, 3, 2, 1, and 0 of the Processor Chassis and all slots of the universal Expansion Chassis are pre-wired with memory module addresses for up to 64KB. It is mandatory that Slot 5 of the Processor Chassis be used for memory. If memory is installed in an Expansion Chassis it is mandatory that one module is installed in Slot 7.
6. The 15 inch system Expansion Chassis, and the basic Processor Chassis may only be used for single board I/O device controllers unless the interconnection between boards takes place via cables installed on the outer edge of the board. For multi-board 10 inch device controllers, the 10 inch system Expansion Chassis must be used.
7. Priority is established by the physical placement within a chassis. Priority for interrupt driven devices should normally be established in order of descending speed, i.e., drum higher than magnetic tape, and card reader higher than a paper tape reader, etc.

INTERDATA Configuration Data Sheet B, Figure 14, indicates possible circuit board distribution in the basic Processor and System Expansion Chassis.

9.3 Back Panel Wiring

The Acknowledge Control line from the Processor carries the Interrupt Acknowledge (ACK) signal. This line breaks up into a series of short lines to form the "daisy-chain" priority system. The ACK signal must pass through every controller that is equipped with Interrupt Control circuits. Refer to Figure 14 to determine order of priority.

Back panel wiring for interrupt control at a given position is: The Received ACK (RACK0) at Pin 122-1 and the Transmitted ACK (TACK0) at Pin 222-1. The daisy-chain bus is formed by a series of isolated lines which connect Terminal 222-1 of a given position to Terminal 122-1 of the next position (lower priority). On unequipped positions, a jumper shorts 122-1 and 222-1 of the same connector to complete the bus. Back panels are wired with jumpers on all positions. Whenever a card chassis position is equipped with a controller, the jumper from 122-1 and 222-1 must be removed from the back panel at that position.

For controllers that occupy several positions, the jumper is removed only at the position where the controller board has ATN/ACK circuits. For details on the various devices, see the appropriate installation specification.

9.4 System Configuration

System configuration data is provided in the User's Manual, Publication Number 29-261.

CONFIGURATION DATA SHEET B, MODEL 7/16, REAR VIEW

SALES ORDER NO.	P.O. OR QUOTE NO.	DATE	REV
CUSTOMER		SHEET	OF
SALESMAN		IN-HOUSE	

- HEXADECIMAL DISPLAY
- BINARY DISPLAY PANEL
- TURN KEY

AUTO LOADER

DEVICE NUMBER

COMMAND BYTE

7/16

MODEL 7/16 PRIORITY	PROCESSOR BOARDS		7
	CONN 0 MPX BUS	CONN 1 SELECTOR OR BUFFERED BUS	
1st 8KB			6
2nd 8KB	6TH PRIORITY	1ST PRIORITY	4
3rd 8KB			3
4th 8KB, SELCH, MBFR			2
5th 8KB			1
6th 8KB, SELCH, MBFR			0

IF MEMORY EXCEEDS 48KB, DO NOT USE SLOTS 0 AND 1 FOR MEMORY MODULES (MAY BE USED FOR I/O)

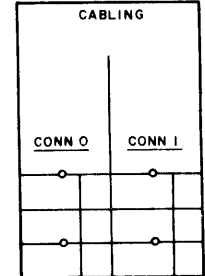

15" EXPANSION PRIORITY	11TH PRIORITY		7*
	CONN 0	CONN 1	
5th 8KB			6*
6th 8KB, SELCH, MBFR			5
7th 8KB			4
8th 8KB, SELCH, MBFR			3
8th 8KB			2
7th 8KB, SELCH, MBFR			1
6th 8KB			0
5th 8KB, SELCH, MBFR			

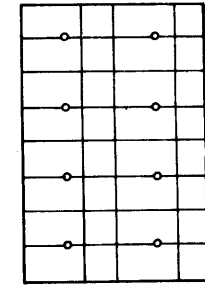

- 17- _____
- 17- _____
- 17- _____
- M49-020
- M49-021**
- M49-000
- M49-002
- M49-022

10" EXPANSION PRIORITY	I/O ONLY		7*
	CONN 0	CONN 1	
I/O ONLY OR MBFR			6*
I/O ONLY			5
I/O ONLY OR MBFR			4
I/O ONLY			3
I/O ONLY OR MBFR			2
I/O ONLY			1
I/O ONLY OR MBFR			0

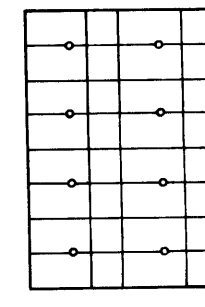

- 17- _____
- 17- _____
- 17- _____
- M49-020
- M49-021**
- M49-000
- M49-002
- M49-022

REMARKS _____

* NOT AVAILABLE ON M49-000
 ** PALS ONLY

Figure 14. Configuration Data Sheet

This information is proprietary and is supplied by INTERDATA for the sole purpose of using and maintaining INTERDATA supplied equipment and shall not be used for any other purpose unless specifically authorized in writing.

9.5 Terminators

The termination end of both legs, Connector 0 and 1, of the Multiplexor Bus must have a standard INTERDATA termination card (35-433) installed. These cards are installed, on the back panel at the lowest numbered slot of both connectors on the Multiplexor Bus that exists, e.g., If a Selector Channel or bus buffer is installed in Slot 4 on the first expansion chassis and only the Processor Chassis and one Expansion Chassis is used in the system, the Multiplexor Bus must be terminated at Slot 0, Connector 0, and Slot 5, Connector 1 of the Expansion Chassis. In addition, the buffered bus or the SELCH Bus should be terminated at Slot 0, Connector 1 of this chassis.

Depending upon system configuration, any SELCH Bus or buffered bus may be terminated by a 15" Terminator (35-433) or a 10" Terminator (35-434). The choice of terminators depends on the type of chassis in which the last slot of the bus is present.

10. CABLES

10.1 Power Cables

The standard INTERDATA Cabinet is wired for 30 Ampere service. On the main power cable (part of the AC Distribution Panel), the 30 Ampere UL plug is a three wire, twist lock, grounding 125 volt V (Hubbell #2611 or equivalent) connector. A 30 Ampere, 125 VAC receptacle (Hubbell #2610 or equivalent) is required to accept this plug. INTERDATA also offers 20 Ampere service with a 20 Ampere UL plug (Hubbell #5364 or equivalent) having one blade perpendicular to the other two blades. A three wire, grounding 20 Ampere 125 VAC receptacle (Hubbell #5362 or equivalent) is required to accept this plug.

10.2 System Expansion Cable

A number of standard cables are available for configuring systems made up of the INTERDATA Expansion Chassis discussed in Section 4. The choice of cables is dependent upon system configuration. The following cables are available:

1. 17-162 and 17-163: I/O and Memory Expansion Cables (see note)

The 17-162 cable is used to connect the "0" connector field and the 17-163 cable is used to connect the "1" connector field from the Processor to the corresponding connector in the first 15 inch expansion file. The expansion file must be mounted immediately below the basic Processor as these cables contain the memory bus which is restricted to the first 15 inch expansion only.

These cables are always used in pairs.

2. 17-193: I/O Expansion Cable, Connector "0"

This cable is used to connect the "0" connector field between two adjacent 15" card files.

3. 17-194: I/O Expansion Cable (see note)

This cable is used to connect the "1" connector I/O fields between two adjacent 15" card files.

4. 17-216: I/O Expansion Cable, 36 Inch Long

This is a 36" long cable. It can be used to connect two 15" files that are not adjacent.

It must not be used to extend the basic Processor Multiplexor Bus.

It can be used to extend a buffered bus or a SELCH Bus. It plugs into a "1" side connector. The "receiving" end can plug into the "0" or "1" side of the expansion file.

5. 17-214: 15" to 10" Expansion Cable

This cable is used to connect the "0" connector field of a 15" card file to a lower adjacent 10" card file. It provides an 8 bit I/O bus to the 10" card file.

6. 17-166: 15" to 10" I/O Expansion Cable, 36 Inch Long

This cable is used to connect the "1" side of a 15" expansion file to a 10" expansion file. It provides an 8 bit I/O bus to a 10" card file.

It must not be connected to the basic CPU Multiplexor Bus.

It may be driven either by a Selector Channel or a bus buffer.

Can be used on the older 10" card file (13 I/O slot).

7. 17-183: "0" to "1" Connector

This cable can be used to interconnect the "0" field and the "1" field within a 15" card file.

It can also be used to connect a "0" side (Slot 0) of a file, to the "1" side (Slot 7) of the next adjacent file, or vice versa.

8. 17-215: 10" to 10" I/O Expansion Cable

This cable is used to connect two adjacent 10" card files.

NOTE

On the receive end of either a 17-163 or 17-194 cable a strap is installed in the factory. This strap must be removed unless the cable is being used to jumper a private I/O Bus (SELCH or bus buffer). This strap jumpers Pin 222-0001 of the upper chassis to Pin 122-0701 of the first expansion chassis. If these cables are used to extend a SELCH or bus buffer the following wiring changes are required on the lower chassis:

Remove the strap from Pin 134-0700 to Pin 122-0701

Add the strap from Pin 134-0700 to Pin 122-0700

M71-SERIES

MODEL 7/16 PROCESSOR

MAINTENANCE SPECIFICATION

1. INTRODUCTION

The Model 7/16 is a low cost, 16 bit general purpose minicomputer. It is a fourth generation Processor suitable for use in data communications, process control, or stand-alone scientific computer applications. The Processor is modularly constructed for ease of maintenance and is compatible with all building blocks in the INTERDATA product line.

2. SCOPE

This specification describes the functional operation of the Model 7/16 Processor and provides maintenance information useful to the digital technician in maintaining this Processor. A block diagram analysis, a micro-program description, and a functional analysis of major Processor areas are included.

3. BLOCK DIAGRAM ANALYSIS

Refer to the Block Diagram in Figure 1.

3.1 System Organization

The Model 7/16 Processor is organized between two 16-bit buses. The B Bus is used to present data to the Arithmetic Logic Unit (ALU). The S Bus then transfers the ALU output to the appropriate destination. The source and destination of data on the B Bus and S Bus, as well as the function performed by the ALU, is controlled by micro-instructions contained in the Read-Only-Memory (ROM).

3.2 Read-Only-Memory (ROM)

The Read-Only Memory is a high speed, solid-state, non-destructive memory organized into three pages of 256 words each. Each word in ROM is 20 bits long and represents one micro-instruction. Each micro-instruction read out of ROM is placed in the 20 bit ROM Data Register (RD). RD is the micro-instruction register for the micro-Processor. Most micro-instructions are executed in one machine cycle of 250 nanoseconds. RD bits are decoded to select a Source to be statically unloaded to the B Bus. The ALU then forms a result on the S Bus. This result becomes available some time before the end of the machine cycle; at the start of the next machine cycle the appropriate destination register is loaded and the next micro-instruction is fetched. The meaning of the micro-instruction word bits is explained later.

Locations in the ROM are addressed by the 10 bit ROM Address Register (RAR). Micro-instructions are normally located at sequential addresses in the ROM. The RAR is an up-counter which increments by one as each new micro-instruction is read into RD. The RAR therefore holds the address of the next micro-instruction to execute. When it becomes necessary to jump out of sequence, RAR can be loaded with a new address from the RD register, from the Decoder Read-Only-Memories, or it can be preset by the hardware.

3.3 Flag Register (FLR)

The Flag Register (FLR) is a four-bit register containing the following flags: Carry (C), Overflow (V), Greater than Zero (G), and Less than Zero (L). These flags are modified at the conclusion of arithmetic and logical micro-operations to reflect the result of the operation. The FLR is loaded from Bits 12 through 15 of the S Bus when either the FLR or the Program Status Word (PSW) is the specified Destination Register.

3.4 Program Status Word (PSW)

The Program Status Word (PSW) is a 16-bit register used to indicate the system status relative to the user program being emulated. Bits 0 through 11 of the PSW define enabled interrupts and the operational status or mode of the user level Processor. Some of the PSW bits have hardware significance while others are of significance only to the micro-program. Bits 12 through 15 of PSW make up the Condition Code field (CC) which reflects the result of the most recent user instruction.

The Condition Code may only be updated from the FLR. When PSW is the specified Destination Register, Bits 0 through 11 of the S Bus are loaded into Bits 0 through 11 of the PSW and S Bus Bits 12 through 15 are captured in the FLR. The Condition Code field remains unchanged until the micro-program causes it to be updated from the FLR or when the hardware, in the case of the Instruction Read, copies the contents of the FLR into the Condition Code.

The Location Counter (LOC) is a 16-bit appendix to PSW which holds the main memory address of the next user instruction to be performed.

3.5 Main Memory

The Main Memory consists of random access memory providing storage for user instructions and data. The Memory Address Register (MAR) is a 16-bit register which is loaded with the address of main memory locations. Memory is actually addressed by the Memory Address Slave Register (MAS). MAS is automatically updated from MAR at the start of each memory cycle. Data read from or written into memory is buffered in the Memory Data Register. The micro-program initiates a main memory cycle by issuing a memory read, memory write, or instruction read command. After issuing a memory command, the micro-program is free to do other instructions. The memory cycle is accomplished asynchronous of other Processor activity. If the micro-program, however, attempts to use the contents of MDR after a memory read or instruction read before memory data becomes available, or attempts to load MDR or issue another memory command before the current memory cycle is complete, the Processor stops until the desired function can be performed.

With core memory, a memory cycle consists of two phases. First, the contents of the specified location are read out and placed into the MDR and replaced by zeros (destructive read-out). The contents of MDR are then written into the specified location. A Memory Read consists of a read cycle that saves the contents of the specified location in MDR. The contents of the MDR are then written back to the specified location on the write cycle. A memory write does not save the read-out so that the specified location is written with the contents of MDR. An instruction read differs from a memory read in that after the data becomes available in MDR, it is automatically transferred to the user's Instruction Register.

3.6 Instruction Register (IR)

After an instruction read has been issued, when the read-out is available in MDR, MDR Bits 0 through 7 are placed in the register labeled OP, Bits 8 through 11 are placed in the register labeled YD, and Bits 12 through 15 are placed in the register labeled YS. These three registers (OP, YD, and YS) comprise the user's Instruction Register.

3.7 Decoder Read-Only Memory (DROM)

The OP register is used to address locations in the Decoder Read-Only Memory (DROM). The DROM is a separate Read-Only Memory, consisting of the two halves - DROM 1 and DROM 2. Each half contains 128 12-bit words. The micro-program can interrogate either DROM 1 or DROM 2 at anytime other than on a Branch or Input/Output micro-instruction. The least significant 10 bits of the resulting read-out are jammed into the RAR, resulting in an automatic branch to an address that is related to the user's operation code. Bit 5 of DROM 1 is used to suppress unnecessary memory reads. Bit 4 of DROM 2 is used to identify the halfword I/O user instructions.

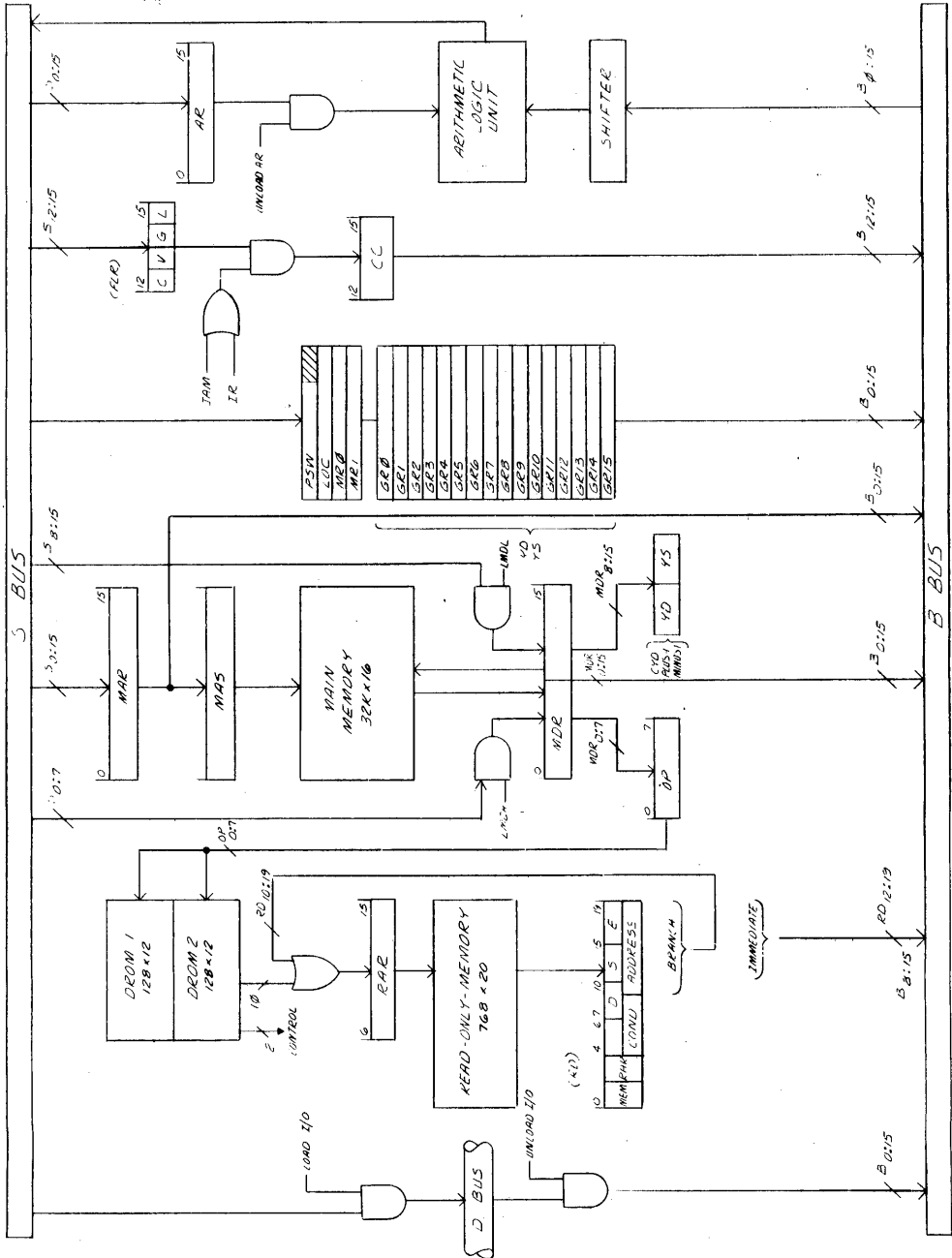
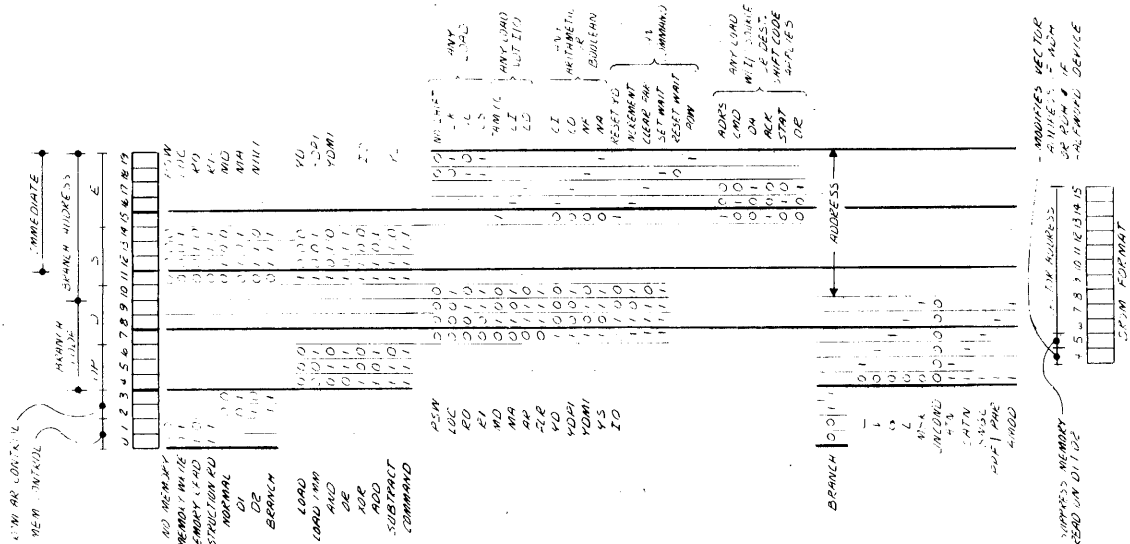

This information is proprietary and is supplied by INTERDATA for the sole purpose of using and maintaining INTERDATA supplied equipment and shall not be used for any other purpose unless specifically authorized in writing.

Figure 1. Block Diagram

3.8 General Registers (GR)

It is most often the case that the micro-program accesses the user's General Registers without caring which of the 16 General Registers it gets. Consequently, no provision has been made in the Model 7/16 for the micro-program to randomly access an explicit General Register. Of course, it matters that when the micro-program accesses a General Register for emulating a user instruction that it be the General Register specified in that user instruction. Since after instruction read, the register address(es) specified by the user are in the YD and YS Register, the micro-program can access the appropriate General Register by specifying the YD or YS Instruction Register. The hardware then selects the General Register whose number is in the YD or YS Register.

The YD Register is an up/down counter so that sequential General Registers can be accessed. The micro-program can also clear the YD Register when it needs to access specific General Registers.

3.9 Micro-Registers (MR)

The two 16-bit registers labeled MR0 and MR1 are available to the micro-program for general purpose use.

3.10 Arithmetic Register (AR)

The 16-bit A Register (AR) holds the second operand for arithmetic and logical micro-operations. It is one of two direct inputs to the Arithmetic Logic Unit (ALU). The other input is the output from the "B" Bus Shifter. The Shifter can shift B Bus data left or right one bit position, do an 8-bit rotate, or gate the "B" Bus directly into the ALU.

3.11 Arithmetic Logic Unit (ALU)

The ALU comprises a 16-bit parallel adder/subtractor logic network with look ahead carry. The arithmetic or logical result is formed on the 16-bit S Bus.

3.12 Input/Output (I/O)

Input/Output operations are achieved by gating S Bus data onto the D Bus and activating an I/O Control Line, or by activating an I/O Control Line and gating the D Bus data onto the B Bus.

4. MICRO PROGRAM DESCRIPTION

4.1 Introduction

Micro-programming is a means for implementing the control logic of a digital computer. At INTERDATA, micro-programming has been effectively used to maintain upward compatibility in a family of Processors whose internal hardware varies from one member to the next.

The Model 7/16 is designed to execute micro-instructions stored in a Read-Only Memory (ROM). Each micro-instruction causes one or more hardware functions to be performed, such as transferring the contents of one register to another, arithmetic or Boolean operations between registers, controlling input/output operations, or initiating main memory accesses.

A series of micro-instructions is called a micro-program. The complete Model 7/16 micro-program is, by definition, an emulator, causing the Model 7/16 hardware to react to a user program in main memory and to external events as would the Processor described in the User's Manual, Publication Number 29-261. Every user instruction, interrupt handling feature, and Hexadecimal Display Panel function is simulated by some portion of the Model 7/16 micro-program.

4.2 Word Formats

4.2.1 General. The Processor executes nine basic micro-instructions. Branch is identified by having Bits 2 and 3 of the micro-instruction word set. For all other micro-instructions, Bits 4, 5 and 6 specify the Op-Code. See Table 1.

TABLE 1. MODEL 7/16 MICRO-INSTRUCTIONS

RD BITS 23 456				SYMBOLIC OP CODE	MEANING
Bits 2 & 3 do not - 11	11	xxxx		B	BRANCH
	xx	0000		L	LOAD
	xx	0011		LI	LOAD IMMEDIATE
	xx	0100		N	AND
	xx	0111		O	OR
	xx	1000		X	EXCLUSIVE OR
	xx	1011		A	ADD
	xx	1100		S	SUBTRACT
	xx	1111		C	COMMAND

Micro-instructions can have any one of three machine language formats, depending upon the specific operation. The formats are listed in the following paragraphs by the micro-instructions which use them.

4.2.2 Add, Subtract, AND, OR, Exclusive OR, Load, and Command.

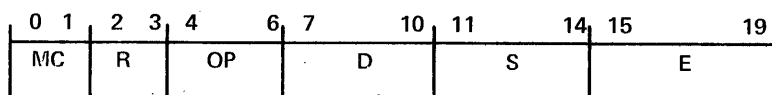

- MC Memory Control field. Memory actions (Memory Read, Memory Write, Instruction Read) are specified in this field.
- R ROM Address Register Control. This field is used to interrogate DROM 1 or DROM 2. If both Bits 2 and 3 are set this is a branch Op-Code.
- OP Specifies the function to be performed.
- D Destination field. The result of the operation is placed in the register specified by this field.
- S Source field. The address of the register containing the first operand is in this field. The second operand, when necessary, is contained in the AR.
- E Extended Operation field. Instruction options are specified in this field.

4.2.3 Load Immediate.

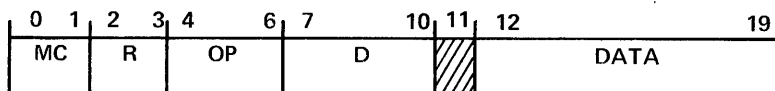

DATA The first operand is in this field. Bit 11 of the instruction is undefined.

4.2.4 Branch.

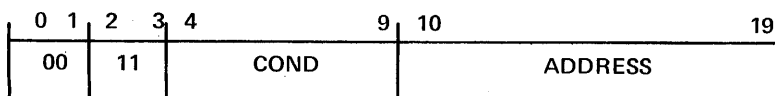

- COND Specifies the condition for branching.
- ADDRESS If the specified condition is true, the program is transferred to the address specified by this field. No memory activity is allowed on a Branch.

This information is proprietary and is supplied by INTERDATA for the sole purpose of using and maintaining INTERDATA supplied equipment and shall not be used for any other purpose unless specifically authorized in writing.

4.3 Source and Destination Registers

Source Registers are available to all micro-instructions except Branch and Load-Immediate. The sources that may be addressed are shown in Table 2.

TABLE 2. ADDRESSABLE SOURCES

RD BITS				SYMBOLIC REGISTER	MEANING
11	12	13	14		
0	0	0	0	PSW	Program Status Word
0	0	0	1	LOC	Location Counter
0	0	1	0	MR0	Micro-Register 0
0	0	1	1	MR1	Micro-Register 1
0	1	0	0	MDR	Memory Data Register
0	1	0	1	MAR	Memory Address Register
0	1	1	0	NULL	Null Source. First Operand=0
0	1	1	1	---	Undefined
1	0	0	0	YD	Register specified by YD field
1	0	0	1	YDP1	Register specified by YD field
1	0	1	0	YDM1	Register specified by YD field
1	0	1	1	---	Undefined
1	1	0	0	IO	Input D Bus to B Bus
1	1	0	1	---	Undefined
1	1	1	0	YS	Register specified by YS field
1	1	1	1	---	Undefined

The source registers may be used freely by the micro-program. The following paragraphs point out special considerations.

The user's 16 general purpose registers do not have individual source addresses. Instead, common symbolic addresses—YD, YDP1, YDM1 and YS—cause the General Registers to be selected from the YD or YS field of the user's Instruction Register. When the source specification is YD, YDP1, or YDM1, the General Register whose number is in the YD field is unloaded to the B Bus. Then, for YDP1 (YDM1) the YD field is incremented (or decremented) by one. When the source specification is YS, the General Register whose number is in the YS field is unloaded to the B Bus.

The General Register specified by YD may not be used as a source immediately after a YDP1 or YDM1 specification; nor may a particular General Register be used as a source immediately after it was a destination. The micro-programmer should allow one micro-instruction worth of settle time for these cases.

When I/O appears as the source, an input operation is to be performed. The nature of the input request is encoded into the extended field of the instruction. When the device responds, the data is gated onto the B Bus. Completion of the micro-instruction is suspended until the device responds or a false sync occurs.

If an attempt is made to unload MDR when the memory data is not yet available (after a memory read), execution of that micro-instruction is suspended until memory data is available. Memory data is unavailable for two machine cycles following a memory read.

When PSW is specified as the source register, only Bits 0 through 11 of the PSW are gated to the B Bus. B Bus Bits 12 through 15 reflect the contents of the Condition Code for this micro-instruction.

Destination Registers are available to all micro-instructions except Branch.

The Destination Registers that may be addressed are shown in Table 3.

This information is proprietary and is supplied by INTERDATA for the sole purpose of using and maintaining INTERDATA supplied equipment and shall not be used for any other purpose unless specifically authorized in writing.

TABLE 3. ADDRESSABLE DESTINATIONS

RD BITS				SYMBOLIC REGISTER	MEANING
7	8	9	10		
0	0	0	0	PSW	Program Status Word
0	0	0	1	LOC	Location Counter
0	0	1	0	MR0	Micro Register 0
0	0	1	1	MR1	Micro Register 1
0	1	0	0	MDR	Memory Data Register
0	1	0	1	MAR	Memory Address Register
0	1	1	0	AR	A Register
0	1	1	1	FLR	Flag Register
1	0	0	0	YD	Register specified by YD field
1	0	0	1	YDP1	Register specified by YD field
1	0	1	0	YDM1	Register specified by YD field
1	0	1	1	YS	Register specified by YS field
1	1	0	0	IO	Output data to D Bus
1	1	0	1	---	Undefined
1	1	1	0	---	Undefined
1	1	1	1	---	Undefined

The Destination Registers may be used freely by the micro-program noting the following special cases.

When PSW is loaded, Bits 12 through 15 of the S Bus are captured in the FLR. PSW Bits 12 through 15 (the Condition Code) are updated from the FLR on an Instruction Read or at any time when directed by the micro-program.

When LOC is loaded, MAR is also loaded with the same value.

Loading LOC or MAR has no immediate affect on MAS. MAS is updated from MAR at the start of each memory cycle.

If an attempt is made to load MDR when memory is busy, execution of that micro-instruction is suspended until the current memory cycle is finished. A memory cycle lasts four machine cycles.

When I/O is the destination, an output operation is to be performed. The nature of the output operation is encoded in the extended field of the Load micro-instruction. S Bus data is gated onto the D Bus. Completion of the micro-instruction is suspended until the device responds or false sync occurs.

When YS is the destination, the General Register specified by the YS field is loaded.

When YD is the destination, the General Register specified by the YD field is loaded.

When YDP1 or YDM1 is the destination, the General Register specified by the YD field is loaded, then the YD field is incremented or decremented by one.

This information is proprietary and is supplied by INTERDATA for the sole purpose of using and maintaining INTERDATA supplied equipment and shall not be used for any other purpose unless specifically authorized in writing.

4.4 The Micro-Program

The Model 7/16 micro-program can be divided into three major functional areas. These are: 1. user instruction fetch; 2. user instruction execution; and 3. interrupt support. Refer to Figure 2.

The user instruction fetch routine tests for interrupts. If any interrupts are pending, the interrupt support routine is entered. If there are no interrupts, the instruction fetch continues. The second operand is placed in the AR and the appropriate instruction execution routine is entered. After finishing the emulated instruction, the next user instruction is fetched.

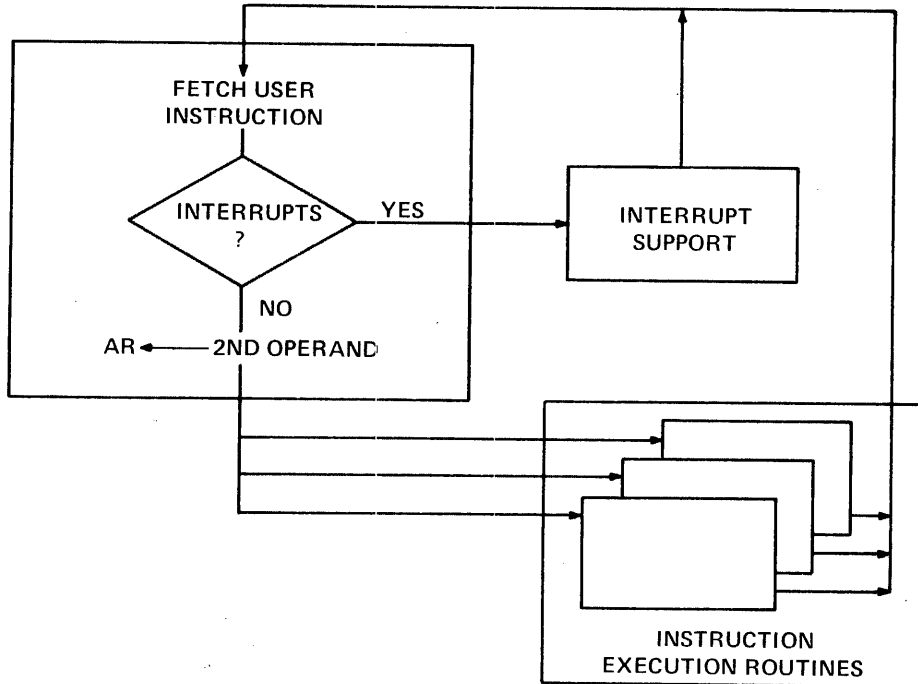

Figure 2. Micro-Program Functional Areas

4.4.1 System Initialization. On power up, or following initialize, when the System Clear signal (SCLR0) goes high, the Processor starts executing micro-instructions. SCLR0 presets the ROM Data Register (RD) to X'30100' if the Auto-Restart option is not present, or to X'30102' if the Auto-Restart option is present. Consequently, the first micro-instruction executed after power up or initialize is the preset unconditional branch to address X'100' or X'102'.

Referring to Figure 3, address X'100' corresponds to the symbolic label PWRUP on the flow chart and address X'102' corresponds to the label ARST. The micro-program loads MR1 with a zero or a one to flag the absence or presence of the Auto-Restart option.

Then the Loader Storage Unit (LSU) is addressed. If the LSU exists, it responds with a sync. The test for false sync fails and routine AUTO1 is entered. If a false sync does occur, the micro-program branches to routine PWRUP2, the normal power-up sequence.

CAUTION

Device Number X'05' is reserved for the Loader Storage Unit (LSU) Controller. This is a device which is treated specially by the hardware during power up or initialize sequences, which automatically loads a new PSW and up to 2,048 bytes of main memory. The hardware assumes if Device Number X'05' exists in a system that it is an LSU and the automatic PSW and memory load sequence occurs on power up. Accordingly, extraordinary results can occur if Device Number X'05' is assigned to any other device controller.

The PSW and LOC are restored from their power fail save locations, X'0024' and X'0026' in main memory, and the user's General Registers are restored from their main memory power fail save locations. The General Register save area is a 32-byte block of memory whose starting address is contained in memory location X'0022'.

After restoring the registers, Bits 13, 14, and 15 of location X'20' are examined. If non-zero, the Hexadecimal Display Panel was not in the Run mode when power went down. Routine PWRUP3 is entered. If zero, the Hexadecimal Display Panel was in the Run mode. The Auto-Restart queue in MR1 is tested. If set, routine MMF is entered to do the Machine Malfunction interrupt if PSW Bit 2 is set. If the ARST queue is not set, routine LOCDIS is entered. Routine PWRUP3 is entered on power up after the registers have been restored, if the Hexadecimal Display Panel was not in the Run mode when power went down. The status byte from the Display Controller is examined. If the least significant four bits of the status are 0X01₂, the Processor is equipped with the Automatic Loader option, and an auto-boot load from a particular device is desired. In this case, the micro-program reads two bytes from the Display Controller. The first byte is the device number and the second byte is the required output command. The device is addressed and the output command is issued, then routine AUTO1 is entered.

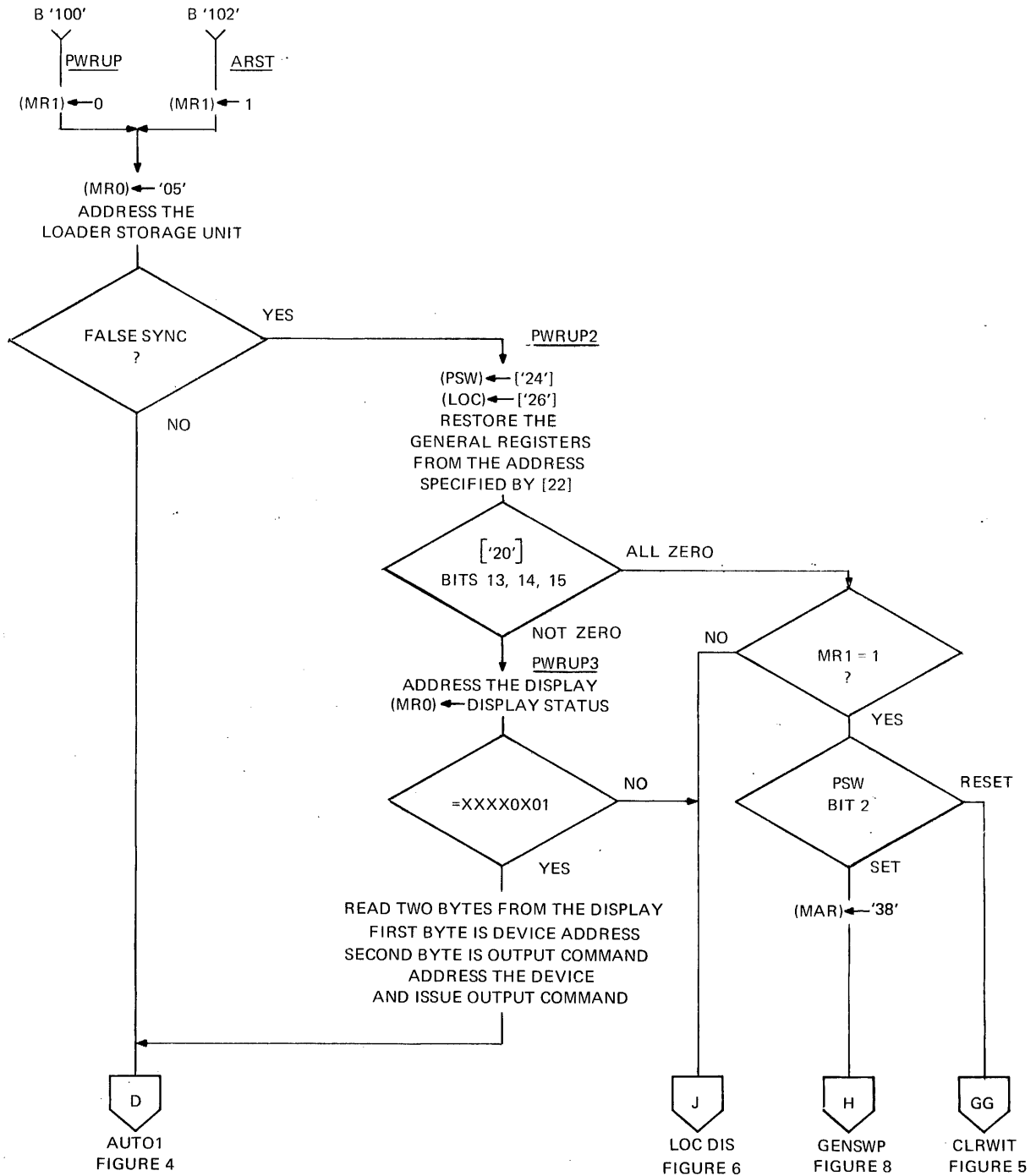

Figure 3. System Initialization

This information is proprietary and is supplied by INTERDATA for the sole purpose of using and maintaining INTERDATA supplied equipment and shall not be used for any other purpose unless specifically authorized in writing.

If the Display Controller status is other than XXXX 0X01₂, then either a Hexadecimal Display Panel is present or the Automatic Loader option exists but no boot load is desired. The micro-program goes to LOCDIS to display the present value of the Location Counter.

The Auto-Boot Load routine, AUTO1 is shown on Figure 4. The micro-program reads in a new PSW and LOC, a starting memory address and an ending memory address from the specified auto-boot device. The tests for busy device status are necessary when devices other than the Loader Storage Unit are used. The micro-program then forms in MR1 the difference between the ending address and the starting address. If a carry is produced, the end address was less than the start address. Routine IDLE is entered. If the end address is not less than the start address, the data input loop, AUTOL, is entered. Any bad status from the device causes the micro-program to go to IDLE. Otherwise, data bytes are read from the device and stored in consecutive byte locations in main memory until the difference count in MR1 is decremented from X'0000' to X'FFFF'. When this happens, all the data has been loaded into main memory and routine TEST2 is entered.

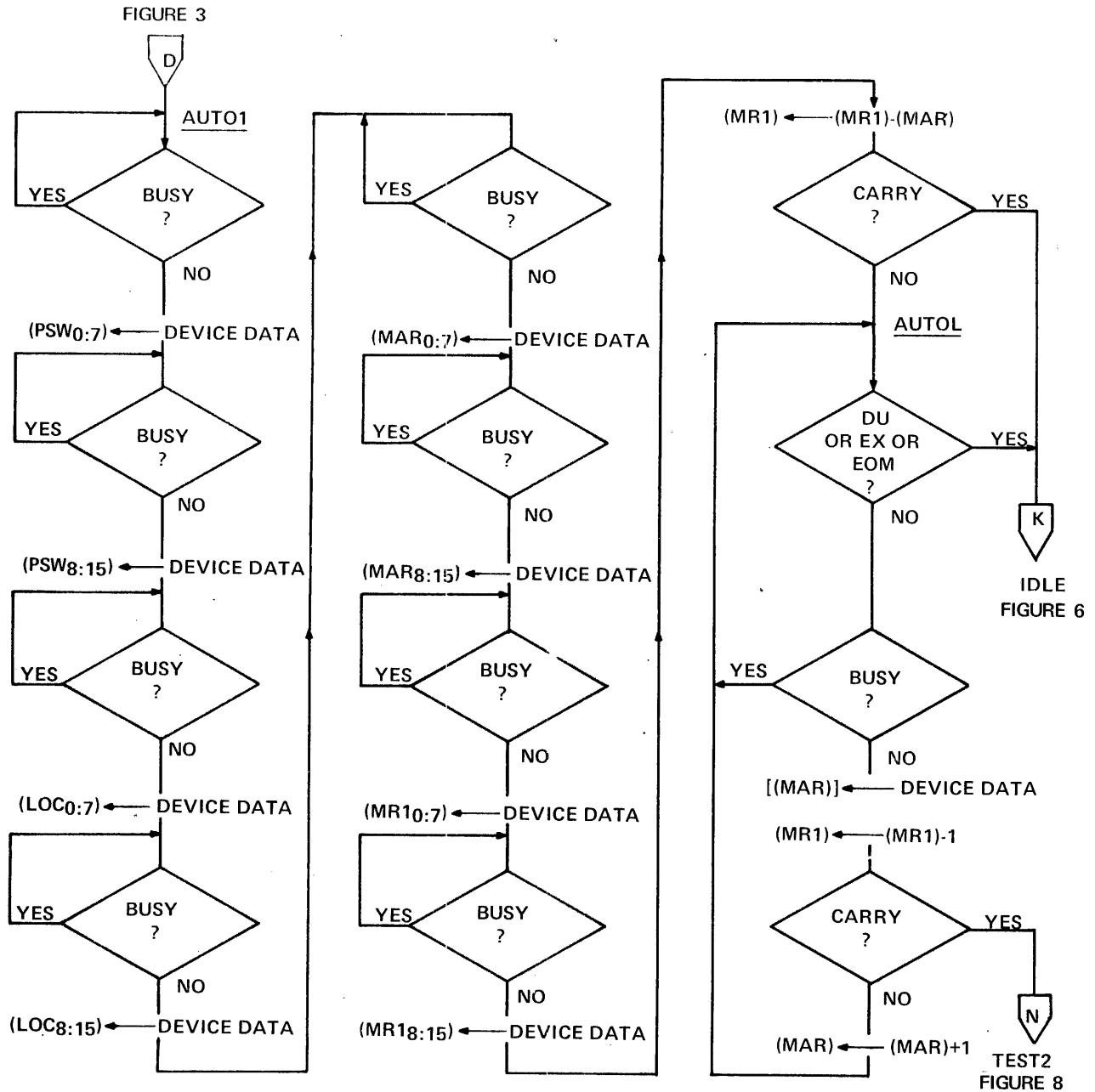

Figure 4. Auto-Boot Loader

This information is proprietary and is supplied by INTERDATA for the sole purpose of using and maintaining INTERDATA supplied equipment and shall not be used for any other purpose unless specifically authorized in writing.

Routine TEST2 is in the general load/swap PSW coding. If Bit 0 of the PSW is set (Wait bit), the micro-program branches to the high speed interruptable WAIT loop. If Bit 0 is not set, the micro-program goes through routine NOB to copy LOC into MAR, update the FLR from the Condition Code, and do an Instruction Read to fetch the first user instruction.

4.4.2 Hexadecimal Display Panel Support. The Hexadecimal Display Panel is serviced by two major routines; CONSER and DISPLY. Routine CONSER is entered if during user instruction execution, the micro-program determines that either CATN or SNGL are active; or if in the IDLE loop or the WAIT loop, CATN becomes active but SNGL is not active. See Figure 5.

The Display Controller is addressed and its status is examined. The most significant four bits of the status byte are stored as the least significant four bits of location X'20'. If the SNGL signal is active the FLR is cleared and the micro-program returns to the user instruction fetch routine at START+1. If SNGL is not active and the Hexadecimal Display Panel is not equipped, routine CLRWIT is entered, which resets the Wait bit in the PSW and fetches the next user instruction.

If status Bit 1 is set a function or a register has been selected. Routine FN is entered. If status Bits 0, 4, 5, 6 and 7 are all reset, Function 0 was selected. If PSW Bit 4 is also set, the micro-code simulates an interrupt from device number 1 (Hexadecimal Display Panel Interrupt). If not enabled by the PSW bit, routine CLRWIT is entered to fetch the next user instruction.

If the Display status indicates Address or Memory Write, routine ADRMW is entered. The Switch Register is read into MDR and if the mode is ADRS, routine ADR is entered; where the data in MDR is forced even, copied to LOC and routine LOCDIS is entered. If the mode is Memory Write, routine DISMEM is entered, where the data in MDR is written to the memory location specified by LOC. LOC is then incremented by two and copied to MR0. The data written is copied into MR1 and MDR is set equal to X'80' to illuminate the Memory Address/Memory Data diagram lamp and clear the MA12:15 field of the display. Routine OUTDIS is entered.

If the mode is Memory Read, the read is performed from the address specified by LOC and routine DISMEM is entered.

Display status Bits 1, 2, and 3 being reset indicate Run mode. Routine CLRWIT is entered to fetch the next user instruction.

Routine DISPLY is entered from routine CONSER if the status indicates that a function other than Function 0 or a Register was selected; or before the interruptable Wait loop is entered, if SNGL is active. See Figure 6.

The Display Controller is addressed and its status is tested. If a General Register is selected, routine REGDIS is entered. If Function codes 4 or 5 are indicated, routine PSWLOC is entered. Otherwise, the uninterruptable IDLE loop is entered.

At REGDIS, the eight-bit status byte in MR0 is rotated left one position so that Bit 0 of the status byte becomes the least significant status bit. The YD field is cleared and incremented until it equals the register number specified by the least significant four status bits. The specified General Register is copied to MR1, MR0 is cleared and MDR is set equal to X'2n', where n is the number of the specified register. Routine OUTDIS is then entered.

At PSWLOC, status Bit 0 is examined to differentiate between Functions 4 and 5. If status Bit 0 is set, the Function is 5 and routine LOCDIS is entered. Otherwise, the PSW is copied to MR1, MR0 is cleared, and MDR is set equal to X'44'.

Routine LOCDIS copies LOC to MR1, clears MR0 and sets MDR equal to X'45'. Routine OUTDIS is then entered.

Routine OUTDIS outputs the five bytes contained in MDR8:15, MR0 and MR1 to the Display Controller. The Controller is then given an output command Normal mode, so that the next time it is addressed the byte counter will reset, then the uninterruptable IDLE loop is entered.

The IDLE loop is a high speed loop that can only be exited if a power failure occurs or a CATN is detected.

4.4.3 Instruction Fetch. A user's Instruction Fetch begins when a micro-instruction specifying Instruction Read is performed. The hardware sets the ROM Address Register to '000', which corresponds to the label START on the flowchart, see Figure 7. If any interrupts are pending, the micro-program branches to routine HELP. If no interrupts are pending, the LOC is incremented by two. The hardware copies the instruction word from MDR into the Instruction Register (OP, YD, and YS). The General Register specified by YS is loaded into the AR and DROM1 is interrogated. If DROM1 read-out Bit 5 is false, a memory read is initiated from the address specified by the new contents of LOC. If DROM1 read-out Bit 5 is active, no memory read occurs.

If the user's operation code is one of the 128 valid op-codes. DROM1 supplies an appropriate address to resume micro-code execution. If the user's operation code is not legal, the hardware sets the ROM Address Register to '008', causing a branch to routine ILEG. There, the LOC is decremented by two, the MAR is set to '0030' and routine GENSWP is entered.

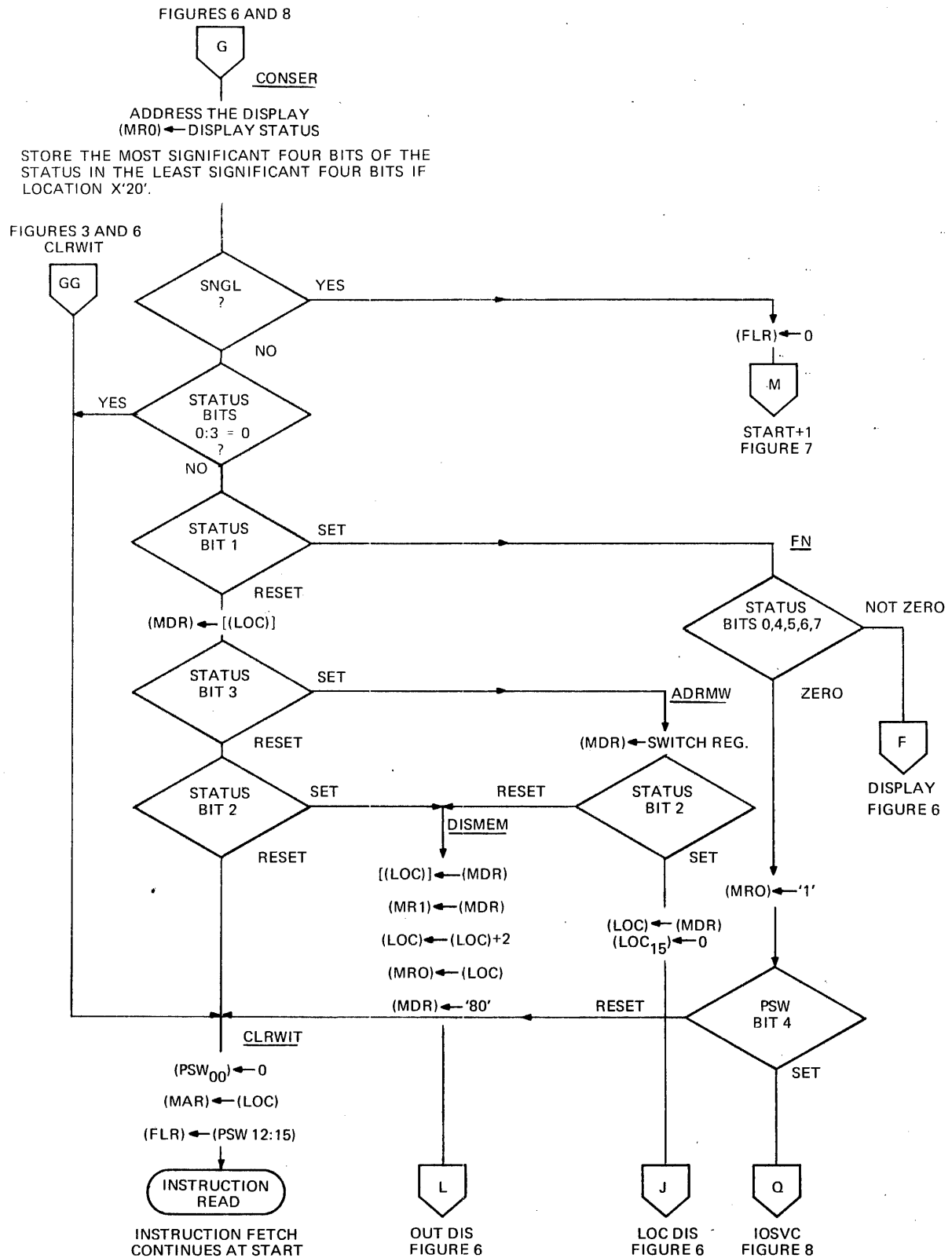

Figure 5. Routine CONSER

This information is proprietary and is supplied by INTERDATA for the sole purpose of using and maintaining INTERDATA supplied equipment and shall not be used for any other purpose unless specifically authorized in writing.

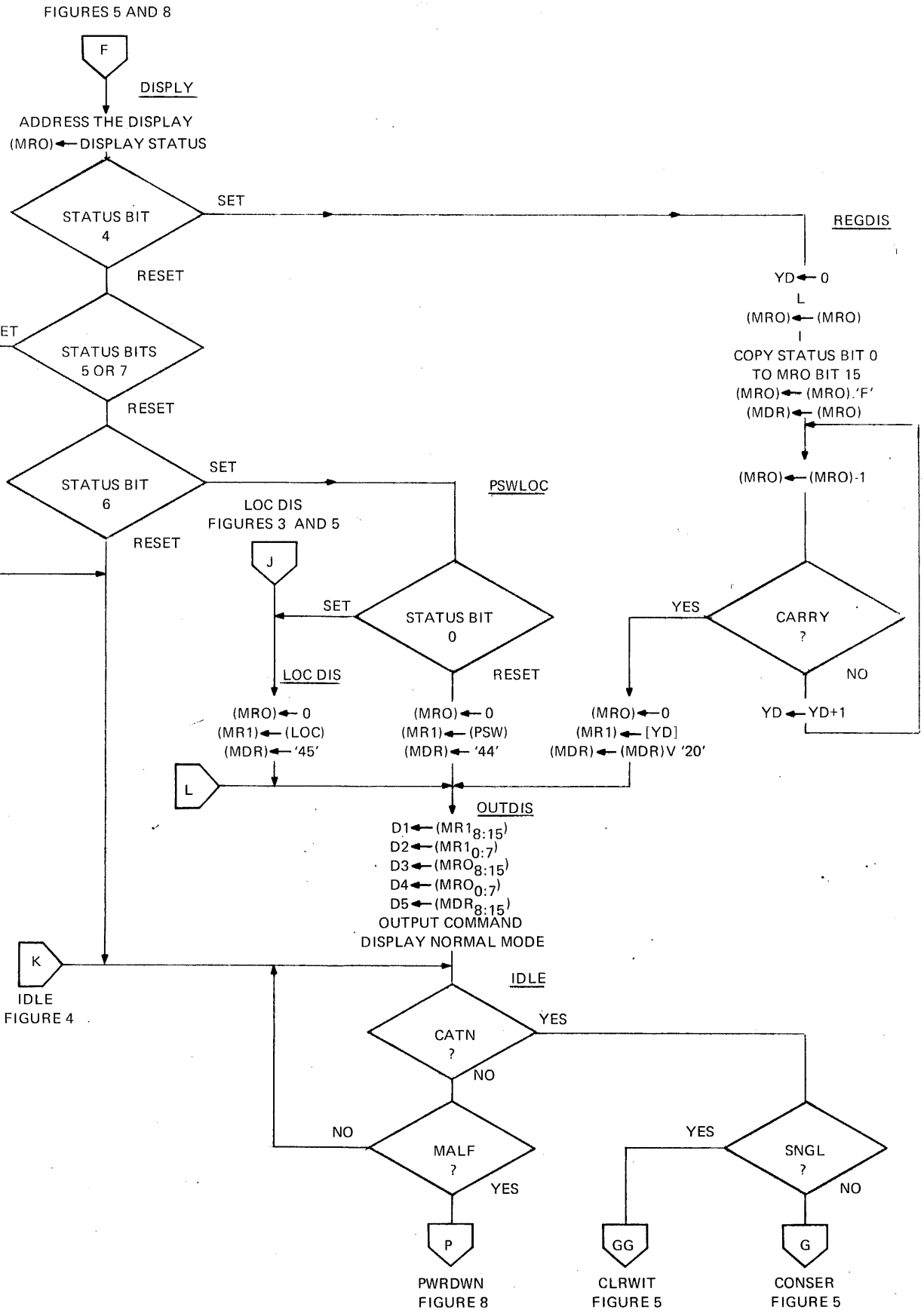

Figure 6. Routine Display

This information is proprietary and is supplied by INTERDATA for the sole purpose of using and maintaining INTERDATA supplied equipment and shall not be used for any other purpose unless specifically authorized in writing.

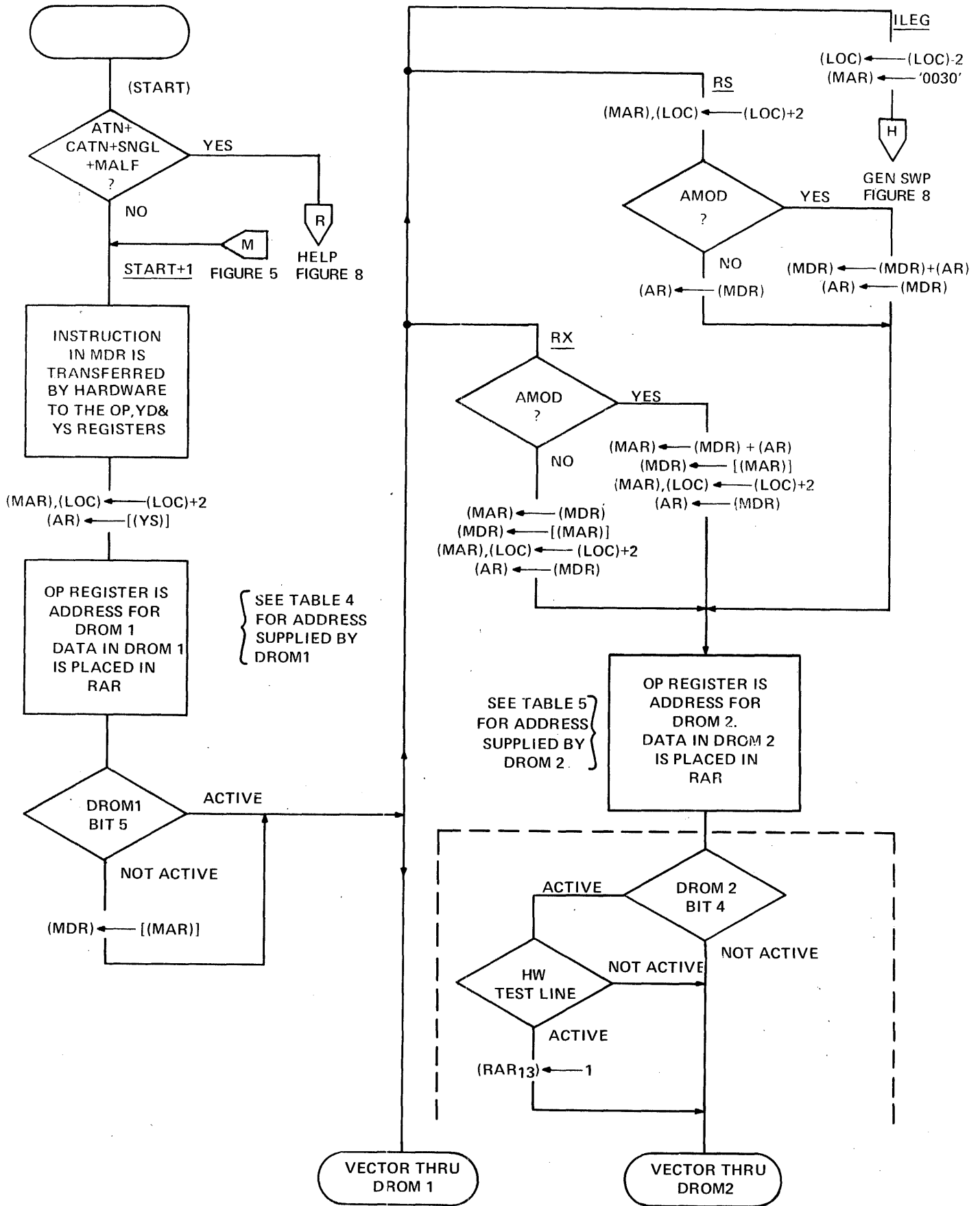

Figure 7. Instruction Fetch

This information is proprietary and is supplied by INTERDATA for the sole purpose of using and maintaining INTERDATA supplied equipment and shall not be used for any other purpose unless specifically authorized in writing.

4.4.4 User Instructions. The ROM address supplied by DROM1, in a way, categorizes the user instructions into those that require operand set-up and those that do not. Table 4 shows the symbolic ROM addresses contained in DROM1. For those instructions that do not require any operand set-up, the micro-program goes directly to the appropriate execution routine via DROM1 and DROM2 is not used at all. For those instructions that do require some pre-processing, after that processing is complete, DROM2 is interrogated to get the starting address of the execution routine. Table 5 shows the symbolic ROM addresses contained in DROM2.

Rather than explain every user instruction, only those more involved instructions are elaborated upon.

TABLE 4. DROM1 DATA

Op-Code MSD	0	2	4	6	9	D	C	E	
Op-Code LSD	0	ILEG*	BTFR*	STH	ILEG*	SRLS*	STMLM*	BXLH	ILEG*
	1	BAL *	BTFR*	RS	STB	SLLS*	STMLM*	BXLH	STMLM*
	2	BTC *	BFFR*	RS	ILEG*	STBR*	STB	RS	RS
	3	BFC *	BFFR*	RS	ILEG*	LBR *	STB	RS	ILEG*
	4	NH *	SHORT*	RX	ILEG*	EXBR*	STB	RS	ILEG*
	5	CLH *	SHORT*	RX	ILEG*	EPSR*	RS	RS	ILEG*
	6	OH *	SHORT*	RX	ILEG*	RWBRR*	RWBRX	RS	ILEG*
	7	XH *	SHORT*	RX	ILEG*	RWBRR*	RWBRX	RS	ILEG*
	8	LH *	ILEG*	RX	ILEG*	RRIO*	RXIO	RS	ILEG*
	9	CH *	ILEG*	RX	ILEG*	RRIO*	RXIO	RS	ILEG*
	A	AH *	ILEG*	RX	ILEG*	RRIO*	RXIO	RS	RLR
	B	SH *	ILEG*	RX	ILEG*	RRIO*	RXIO	RS	RLR
	C	MH *	ILEG*	RX	ILEG*	MHU *	RX	SRH	SR
	D	DH *	ILEG*	RX	ILEG*	RRIO*	RXIO	SLH	SL
	E	ACH *	ILEG*	RX	ILEG*	RRIO*	RXIO	SRH	SR
	F	SCH *	ILEG*	RX	ILEG*	AIR *	AI	SLHA	RLR

*Bit 5 of the DROM read-out suppresses Memory Read.

TABLE 5. DROM2 DATA

	0	2	4	6	9	D	C	E
0	-	BKWD	STH1	-	SRHL	STM	BXH	-
1	-	FRWD	BAL	AHM	SLHLL	LM	BX1E	SVC
2	-	BKWD	BTC	-	NOCCC	STB1	LPSW	SINT
3	-	FRWD	BFC	-	NOCCC	LB	THH	-
4	-	LH	NH	-	NOCCC	CLB	NH	-
5	-	LCS	CLH	-	TEST1	AL	CLH	-
6	-	AH	OH	-	WB	WB	OH	-
7	-	SH	XH	-	RB	RB	XH	-
8	-	-	LH	-	WHR*	WH*	LH	-
9	-	-	CH	-	RHR*	RH*	CH	-
A	-	-	AH	-	WD	WD	AH	RRLI
B	-	-	SH	-	RDR	RD	SH	RLLL
C	-	-	MH	-	-	MHU	SRHL	SRL
D	-	-	DH	-	SSR	SS	SLHLL	SLL
E	-	-	ACH	-	OC	OC	SRHA	SRA
F	-	-	SCH	-	SSR	SS	SLHAL	SLAL

*Bit 4 of the DROM read-out forces RAR Bit 13 set if the Halfword Test Line is active.

Multiply Halfword.

When the routine MH is entered, the AR contains the second operand and the first operand is in the General Register whose address is the value of the YD field plus 1. The General Register pair specified by (YD) and (YD+1) contains the final product. Initially, the micro-program clears the most significant 16 bits of the product in (YD).

The sign of the result product is calculated and saved in MDR and then the multiplier and multiplicand are forced positive. The multiply loop is then entered where the 32 bits in (YD) and (YD+1) are shifted right, double precision, one position at a time. Each time a carry is produced, the multiplier, which was saved in MR0, is added to the most significant 16 bits of the partial product forming in (YD) and (YD+1). The loop is transversed 16 times. At the end of the loop, the 32 bit product is shifted right one more time to make room for the sign bit, then the sign bit in MDR is affixed.

The Unsigned Multiply halfword instruction is identical to the signed multiply with the exception of the sign pre and post processing.

Divide Halfword.

When routine DH is entered, the 16 bit divisor is in the AR and the 32 bit dividend is in the General Register pair specified by (YD) and (YD+1). Initially, the micro-program calculates the sign bit in MDR Bit 15. The dividend sign, which will be the remainder sign, is saved in MDR Bit 14. The divisor is moved from the AR to the MAR and is tested. If minus, routine OKDIV is entered. If positive, routine COMSOR is entered. If zero, routine DFAULT is entered.

Routine COMSOR two's complements the divisor in MAR so that it will be negative, then routine OKDIV is entered. There, the dividend in (YD) and (YD+1) is moved to MR0 and MR1. If it was negative, it is two's complemented.

This information is proprietary and is supplied by INTERDATA for the sole purpose of using and maintaining INTERDATA supplied equipment and shall not be used for any other purpose unless specifically authorized in writing.

In the divide loop, the divisor in MAR is added to the most significant 16 bits of the dividend in MR0, leaving the difference (remember that the divisor is negative and the dividend is positive) in MR0. If a carry did not result, the attempted division was unsuccessful so MR0 is restored by subtracting MAR from it. Then the MR0, MR1 register pair is shifted left one position and the carry from the trial addition is shifted into Bit 15 of MR1. These carries constitute the result quotient forming in MR1; MR0 contains partial remainders. The divide loop is traversed 17 times.

At the end of the divide loop, the remainder in MR0 is shifted right one place. If a carry results, routine DFAULT is entered. A carry at this point means that the dividend was larger than the divisor by a factor of 2^{16} .

The sign of the quotient in MR1 is then examined. If it is positive, the result quotient and remainder signs are affixed, MR0 and MR1 are copied back into (YD) and (YD+1), and the emulation is complete.

If the sign of the quotient in MR1 is negative, then the dividend was equal to or greater than 2^{15} times the divisor. Only the equal case is allowable, meaning that the quotient should be considering signs, equal to X'8000' or -32,768. Any other quotient means a divide fault and routine DFAULT is entered.

Routine DFAULT causes a PSW swap with core location X'0048' if PSW Bit 3 is set. If the enabling PSW bit is not set, the emulation is completed without modifying (YD) or (YD+1).

4.4.5 Interrupt Support. During user instruction fetch, the micro-program tests for interrupts. If any of the tested interrupts (MALF, ATN, CATN, SNGL) are active, routine IHELP is entered. See Figure 8.

Machine Malfunction If MALF is active, routine TEST is entered. MALF can be caused by Memory Parity Error or Early Power Fail if PSW Bit 2 is set; or by Primary Power Fail. At routine TEST, the micro-program clears the memory parity error and early power fail alarms. If MALF is still active, then the Primary Power Fail signal is active. Routine PWRDWN is entered. There, the PSW and LOC are stored in their core memory save locations and the user's General Registers are saved in the area of core whose starting address is contained in location X'0022'. The Command Power Down micro-instruction is then performed which stops the Processor and closes the initialize (SCLR) relay.

If Primary Power Fail was not causing MALF, the micro-program does a Machine Malfunction PSW swap with location X'0038'. Routine GENSWP, the common PSW swap routine, is discussed later.

I/O Attention If MALF is not active, the micro-program tests for I/O attention (ATN). If ATN is active, routine TEST0 is entered. If PSW Bit 4 is set, routine HSSVC is entered, otherwise, a PSW swap is performed with location X'0040'.

Routine HSSVC acknowledges the I/O interrupt. The returned device number times two is used to index the Service Pointer table beginning at core location X'00D0'. The halfword contained in the selected location is fetched and placed in MAR. The micro-program then stores the PSW in the location whose address is (MAR) and the LOC in the location whose address is (MAR)+2. The contents of the location whose address is (MAR)+4 is fetched and placed in the PSW, LOC is set equal to (MAR)+6, and the user instruction now pointed to is fetched and executed.

Console Interrupt If neither MALF nor ATN are active, the micro-program tests for Console Attention (CATN). If not active, the interrupt must have been SNGL, and routine DISPLY is entered. There, the selected register(s) is output to the Display Console and then the Idle loop is entered. See Section 4.4.2.

If CATN is active, routine CONSER is entered. There, the Display Console is addressed, which resets CATN indication. If SNGL is then also active, the micro-program continues the user instruction emulation. When the next user instruction fetch begins, CATN is inactive but SNGL is still present, causing routine DISPLY to be entered. See Section 4.4.2.

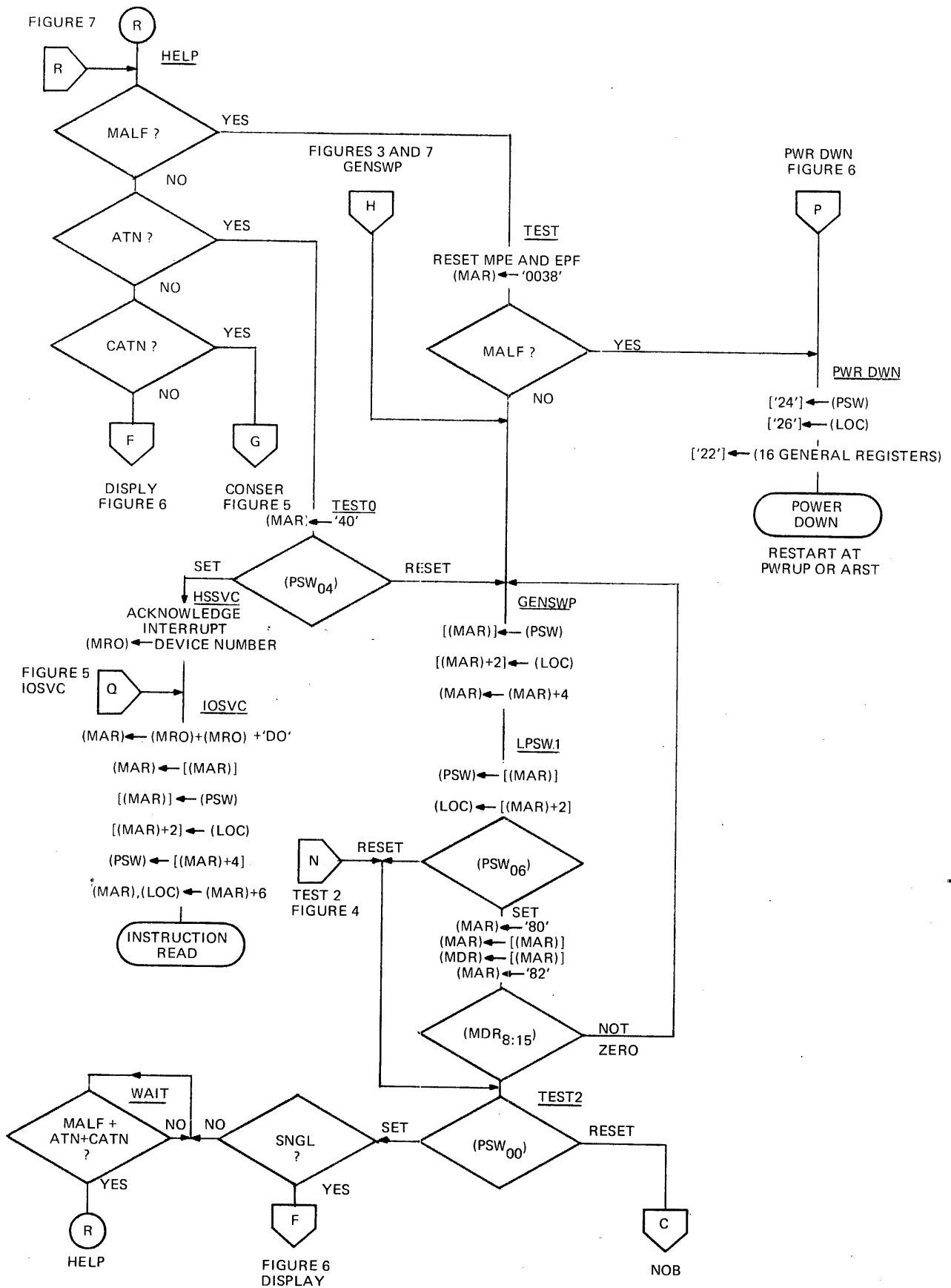

Figure 8. Interrupt Support

This information is proprietary and is supplied by INTERDATA for the sole purpose of using and maintaining INTERDATA supplied equipment and shall not be used for any other purpose unless specifically authorized in writing.

Routine GENSWP

Routine GENSWP is the common PSW swap routine, entered with MAR containing the address of the swap area. The PSW is stored in the location whose address is (MAR). IOC is stored in the location whose address is (MAR)+2. The PSW is loaded with the contents of the location addressed by (MAR)+4 and IOC is loaded from location (MAR)+6.

If Bit 6 of the new PSW is set, the micro-program examines Bits 8:15 of the halfword whose address is in location X'0080'. If this byte is non-zero, another PSW swap is performed immediately with location X'0082'. If Bit 6 of the new PSW is not set, the micro-program tests PSW Bit 0. If not set, user instruction execution begins with the instruction specified by IOC. If Bit 0 is set, the interruptable WAIT loop is entered. The WAIT loop tests for MALF, ATN, or CAEN. If any interrupt occurs, routine HELP is re-entered.

4.5 Interrupt System

The interrupt structure provides rapid response to external and internal events that require special software attention. The descriptions that follow are oriented towards the emulator.

4.5.1 Internal Interrupts. Five different internal interrupts may be generated. Of these, the Fixed-Point Divide Fault, Queue Service, and Supervisor Call Interrupts are created by the Emulator, and the Illegal Instruction and Machine Malfunction Interrupts are generated in the hardware.

4.5.1.1 Illegal Instruction Interrupt. The illegal instruction interrupt occurs when an instruction not in the user's repertoire is attempted. Table 6 shows the Model 7/16 user's instruction repertoire. Only 128 of the possible 256 combinations of Op Codes are available in the DROM. The 128 that aren't available are trapped by the hardware when DROM1 is interrogated. The RAR is automatically set to '008', the starting address of the Illegal Instruction Interrupt micro-routine. Of the 128 allowable combinations, there are still some illegal instructions. For these Op-Codes, the data in DROM1 equals '008'. When DROM1 is interrogated, a branch to ROM address '008' occurs.

TABLE 6. USER'S INSTRUCTION REPERTOIRE

OP CODE BITS 4:7	OP-CODE BITS 0:3							
	0	2	4	6	9	C	D	E
0		BTBS	STH		SRLS	BXII	STM	
1	BALR	BTFS	BAL	AHM	SLLS	BXLE	LM	SVC
2	BTCR	BFBS	BTC		STBR	LPSW	STB	SINT
3	BFCR	BFFS	BFC		LBR	THI	LB	
4	NHR	LIS	NII		EXBR	NHI	CLB	
5	CLHR	LCS	CLH		EPSR	CLHI	AL	
6	OHR	AIS	OII		WBR	OHI	WB	
7	XHR	SIS	XII		RBR	XHI	RB	
8	LHR		LII		WHR	LHI	WH	
9	CHR		CII		RHR	CHI	RII	
A	AHR		AH		WDR	AHI	WD	RRL
B	SHR		SII		RDR	SHI	RD	RIL
C	MHR*		MH*		MHUR*	SRIIL	MHU*	SRL
D	DHR*		DH*		SSR	SLHL	SS	SLL
E	ACHR		ACH		OCR	SRIIA	OC	SRA
F	SCHR		SCH		AIR	SLHA	AI	SLA

*Completed only with M71-105 Multiply/Divide option.

This information is proprietary and is supplied by INTERDATA for the sole purpose of using and maintaining INTERDATA supplied equipment and shall not be used for any other purpose unless specifically authorized in writing.

4.5.1.2 Machine Malfunction Interrupt. The Machine Malfunction Interrupt occurs on a memory parity error or early power fail if PSW Bit 2 is set. The emulator also performs a Machine Malfunction PSW swap on Power Up if PSW Bit 2 is set, Auto-Restart is present, and the Run mode is specified.

If the Memory Parity option is present, the parity bit of each halfword in main memory is set or reset to maintain odd parity. The parity bit is generated on every memory write and checked on every memory read or instruction read. If a parity error occurs, and PSW Bit 2 is set, the testable signal MALF goes active. During the user instruction fetch part of the micro-program, MALF, along with other interrupts, is tested. If any interrupt is pending, the micro-program branches to a routine to sort interrupts by priority.

The Early Power Fail condition (EPF) exists if the optional power fail detector determines that the line voltage is low. The condition also occurs when the Initialize key is depressed or when the Power switch is turned off. One millisecond after Early Power Fail, the Primary Power Fail signal (PPF) goes active. The testable signal MALF is active if EPF is active and PSW Bit 2 is set or if PPF is active. When the micro-program does a Command Clear Memory Parity, the EPF flag is also reset.

4.5.2 External Interrupts. If individually enabled by the user's program, a peripheral device controller is allowed to request Processor service when the device itself is ready to transfer data. If PSW Bit 1 is reset, I/O device interrupt signals are ignored. The signal (ATN) remains pending, however, until PSW Bit 1 is set and the interrupt is acknowledged.

The Processor may service an I/O interrupt in one of two ways, depending on the state of PSW Bit 4. Refer to Figure 8.

5. FUNCTIONAL DIAGRAM ANALYSIS

5.1 Introduction

This section relates to Functional Schematic 01-058D08, Sheets 4 through 26. Note that in INTERDATA functional schematics, the last character in the mnemonic symbol designates the logic level when the signal is active. For example; D050 is Data Line Number 5 (D05). The last character (0) indicates that when D050 is active, the line is at a logical zero level. Refer to the General Description section of this manual for further information concerning the INTERDATA documentation system.

5.2 Clock Control

The Clock Generator is shown on Sheet 12. The clock system employs a free running 16 MHz oscillator. The oscillator output is inverted to generate OSC0. The oscillator is adjustable (via the variable Capacitor C1), over the range of 55 to 120 nanoseconds.

OSC0 is used as the clock inputs to a pair of flip-flops arranged as a two bit counter. The outputs from this counter are ANDed to form Clock (CLK1). CLK1 is the basic clock of the Model 7/16 from which all other clocks are derived. The counter is initialized and held in this initialized state by STOP0, on a power down or a power up, to inhibit clocks. Refer to Figure 9 for clock timing.

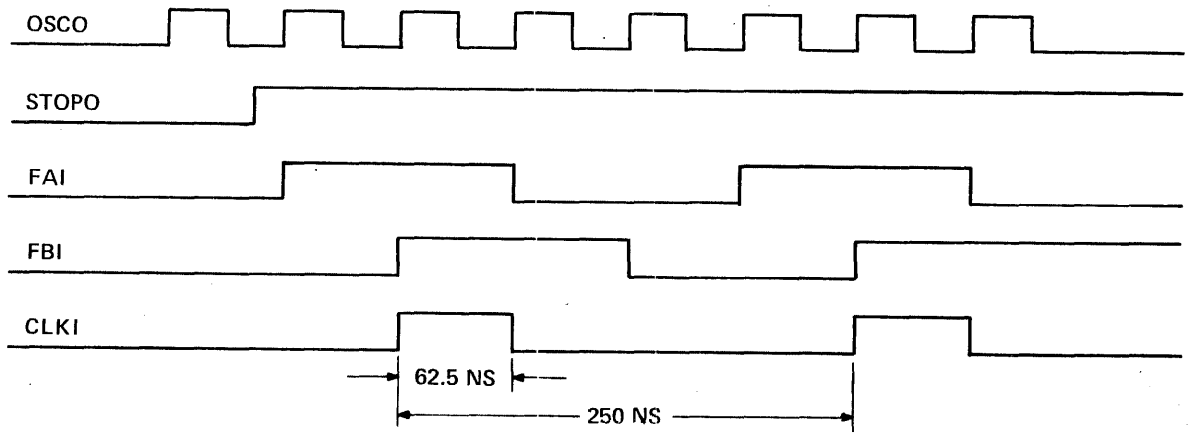

Figure 9. Clock Timing Nominal

This information is proprietary and is supplied by INTERDATA for the sole purpose of using and maintaining INTERDATA supplied equipment and shall not be used for any other purpose unless specifically authorized in writing.

The clock control logic of the Model 7/16 is shown on Sheet 13 of the functional schematics. All the clock inputs to all flip-flops or registers are derived from CLK1 and are delayed from CLK1 by one and only one TTL gate delay.

C-Clock (CCLK1) (13N5) is used to generate the Load ROM Address Register pulse LRAR0 on either a Branch, a Decode, or an Instruction Read Op Code and to provide a clock for the generation of Input/Output timing. CCLK1 is disabled when MSTOP0 is active.

Clock ROM Data (CKRD0) (13H6) is used to increment the ROM Address Register and to strobe data from the ROM into the ROM Data Register. CKRD0 is skipped whenever RSTOP0 is active.

B-Clock (BCLK1) (14H5) is used to synchronize the memory control logic. This clock is an uninhibited clock and is present whenever CLK1 is present.

Various clocks are used for gating data into Processor registers. These clocks, loosely defined as destination clocks, are inhibited by DSTP0.

A hierarchy of clock stops controls the clock system in the Processor. Memory Stop (MSTOP0) stops all clocks except BCLK1 which is used for memory control. Stop I/O (STPIO0) stops all clocks except CCLK1 which is used to control I/O operations. In addition, destination clocks and CKRD0 are skipped for one clock cycle for any micro-instruction which specifies an Instruction Read or a Decode. On a branch micro-operation, no destination clock is generated and one CKRD0 is skipped if the branch is taken. This hierarchy, as well as the structure of the micro-program, insures that Processor clocks are stopped for one reason only.

The SKIP flip-flop (13K8) provides the capability of skipping a clock while performing a Decode, an Instruction Read, or a true Branch. These micro-instructions require two machine cycles for their execution. This flip-flop is set for any of the above reasons and is always reset on the next CLK1.

For the sake of illustration, the timing for an Instruction Read sequence is shown in Figure 10.

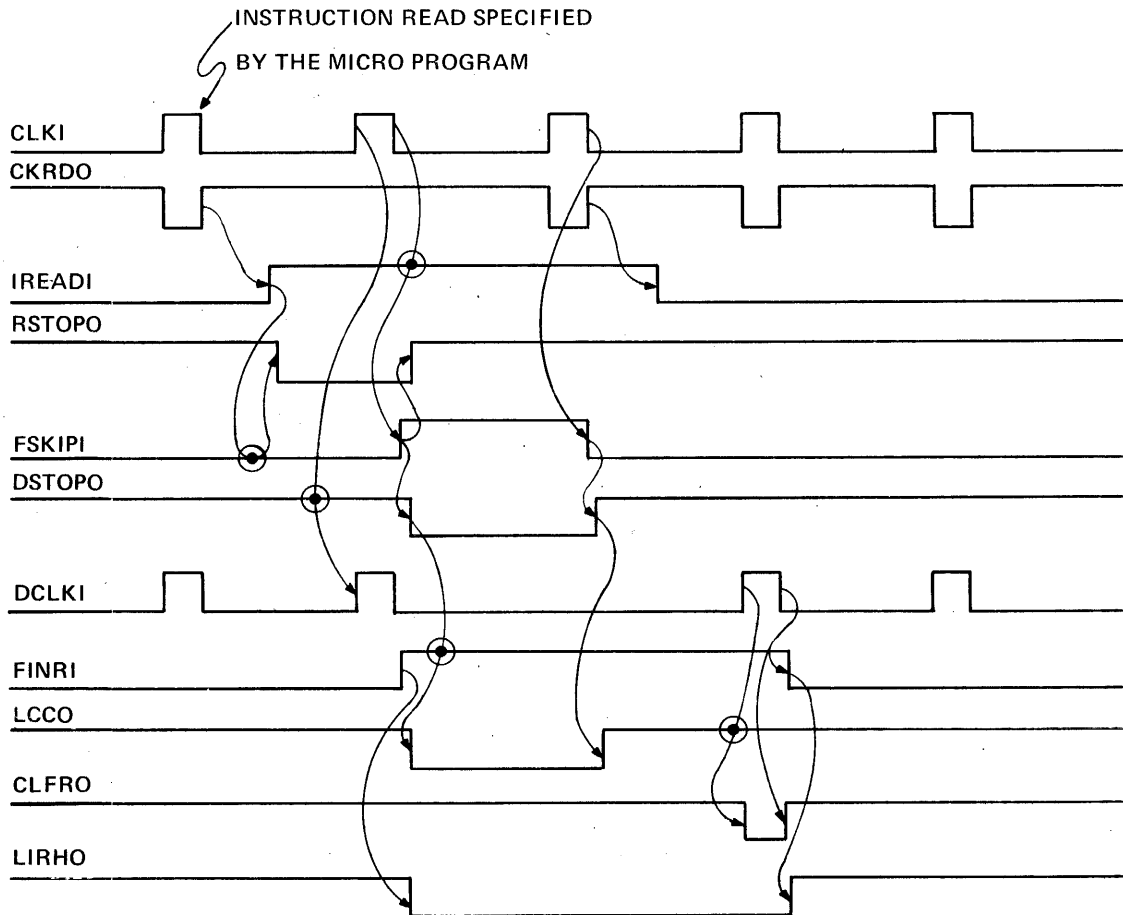

Figure 10. Instruction Read Timing

This information is proprietary and is supplied by INTERDATA for the sole purpose of using and maintaining INTERDATA supplied equipment and shall not be used for any other purpose unless specifically authorized in writing.

5.3 Initialize Control

System initialization is performed by de-energizing the System Clear (SCLR) relay (12H9 and 12A4). This relay is de-energized as a result of one of the following conditions.

1. Placing the Processor in the OFF position.
2. Operating the Processor Initialize key.
3. Activating PFDT0 by the watchdog timer feature of the optional Loader Storage Unit or other external source.
4. Activating PFDT0 from the optional Primary Power Fail detection if the AC input level falls below a minimum operating level.
5. Loss of either +5VDC or -15VDC from the Processor power supply.

The SCLR function provides an orderly shut down of the Processor as well as a reset signal to both the memory and the Multiplexor Bus. On a power up, the SCLR relay remains deactivated until all DC voltages are in regulation. This assures predictable initial states of latched functions.

An Early Power Fail indication is provided to the user program if Bit 2 of the PSW is set. This indication is provided by the micro-program by means of a machine malfunction interrupt swap.

Upon receipt of a power down indication, PFDT0 (12D7) active, by the hardware, the one millisecond timer (12G7) is triggered. The leading edge of this pulse sets the Early Power Fail flip-flop (12K4) which in turn enables, if PSW Bit 2 is set, a branch on machine malfunction to be taken by the micro-program. The micro-program then issues a Command Reset Parity to differentiate between a power fail indication or either an Early Power Fail or Parity Fail. If this Command, RPAR0 active, is not successful in resetting the machine malfunction indication, Power Fail is indicated and the micro-program commences its power down routine. In the event the machine malfunction indication was reset, the micro-program causes a machine malfunction interrupt swap and if the machine malfunction was caused by an Early Power Fail, the less than flag is set in the condition code of the new PSW by copying the contents of the Buffered Early Power Fail flip-flop BEPF (12M4) on the Load PSW (LPSW1 active) micro-instruction. On the trailing edge of the pulse from the one millisecond timer, the Power Fail flip-flop (12H6) becomes set, initiating a power down sequence.

The optional Primary Power Fail Detector (Sheet 12) monitors the AC input by sampling the secondaries of a 12VAC transformer, C₁ and C₃, from the Processor power supply. If the AC is lost or if the AC falls below a preset level, PFDT0 (12K9) and POWDN0 (12K7) become active. PFDT0 initiates the power down sequence and POWDN0 provides a fast discharge path for Capacitors C₅ and C₆ which de-energizes the SCLR relay and holds the relay off in the event the AC is fluctuating about its preset power down level.

5.4 Read-Only-Memory

The Read-Only-Memory (ROM) is a high-speed, solid-state, non-destructive memory used to hold the micro-program. The ROM is organized into pages of 256 20-bit words. Each page of ROM contains five integrated circuit (IC) packages arranged such that each integrated circuit holds four-bits of each word on the associated page.

The Model 7/16 micro-program is complete in three ROM pages and fifteen ROM integrated circuits. Three additional ROM integrated circuits comprise the Decoder ROM (DROM).

Each ROM integrated circuit has two enable leads. Both enables have to be low before a read-out is obtained. If the enables are false, the four data output leads are high. Address decoding is done internal to the IC.

5.4.1 Decoder Read-Only-Memory. The Decoder Read-Only-Memory (DROM) consists of the three ROM integrated circuits shown on Sheet 4. Each IC contains 256 four-bit words. The DROM is addressed by a decoded function of the eight most significant bits of the Instruction Register (Op Code field). Each of the 128 possible combinations of this decoded function may address two locations in the DROM depending on the state of RD021. When this function is low, one of the first 128 words of the DROM is selected, corresponding to a micro-code D1, when high, the second half is selected and a D2 is indicated. If an illegal instruction is decoded by the hardware, the DROM is disabled.

This information is proprietary and is supplied by INTERDATA for the sole purpose of using and maintaining INTERDATA supplied equipment and shall not be used for any other purpose unless specifically authorized in writing.

5.4.2 ROM Address Register. The ROM Address Register (RAR) (Sheet 4) is a ten bit register which is loaded from the false SRAXX0 bus. This bus contains the data from the DROM during a Decode micro-operation and the RD register during a Branch micro-operation. In addition, SRA120 is forced low if an Illegal instruction is detected (9R4) and SRA130 is forced low for a data transfer in the Halfword (16-bit) mode. The eight least significant bits of this register are arranged as a counter so that sequential ROM addresses, in a given page, may be selected.

5.4.3 ROM Data Register. The contents of the ROM from the selected address are loaded into the ROM Data Register (RD) (Sheet 5) on the trailing edge of Clock RD (CKRD0). The RD is a 20 bit register which can be thought of as the micro-instruction register. Refer to the Micro-Program Description section of the specification for the micro-instruction word format.

The RD is initialized by SCLR on a power up to either an X'30100', in the normal mode, or an X'30102' with the auto re-start option installed. This is decoded as an unconditional branch to either address X'100' or X'102' which starts the micro-program execution at the specified location.

5.5 Processor Registers

The majority of instructions in the micro-program are concerned with moving data from one Processor register to another. This transfer takes place by way of the 16-bit B and S Buses and modification of the data, under control of the micro-program, is done by either the Arithmetic Logic Unit (ALU) or the Shifter. Most of the Processor registers are general purpose but a few of them perform special functions. Each register is described in the following paragraphs.

5.5.1 Memory Address Register and Memory Address Slave. The Memory Address function of the Model 7/16 is accomplished in two steps. First, the selected address is loaded by the micro-program into the Memory Address Register (MAR) and then, the hardware copies the contents of the MAR into the Memory Address Slave (MAS) at the beginning of a memory cycle and presents this address to the memory. The micro-program is then free to modify the contents of the MAR.

Both registers are 16-bit registers and are shown on Sheet 16. The MAR is loaded from the S Bus whenever either the MAR or the LOC is specified as a destination and its outputs are dumped onto the B Bus if MAR is decoded as a source register or are loaded into the MAS at the beginning of a memory cycle on the leading edge of LMAS0.

5.5.2 Memory Data Register. The Memory Data Register (MDR) is shown on Sheets 18 and 19. This register is divided into two parts MDR High and MDR Low and each half is located on its corresponding Processor board CPU-HH and CPU-LO. On a memory read operation, the MDR is first direct cleared by either CLMDH0 or CLMDL0 and then each active bit from the memory Strobed Data Lines (MS000:160) direct sets its corresponding bit in the MDR. The MDR may also be loaded from the S Bus when it is specified as a destination register by the micro-program. When loading from the S Bus, if Cross Shift is specified, only MDR High is loaded when Bit 15 of the MAR is set and only MDR Low is loaded when Bit 15 is reset.

The outputs of the MDR are presented to the Memory during the write portion of a memory cycle, to the B Bus if MDR is a source register and, to the Instruction Register in the case of an Instruction Read.

5.5.3 Instruction Register. The Instruction Register (IR) is a 16-bit register which stores the user instruction presently being executed. The IR is divided into three parts or fields; OP code field (Bits 0:7), YD field (Bits 8:11), and YS field (Bits 12:15). The IR is loaded from the MDR, by the hardware, on an Instruction Read. Refer to Figure 10 for timing information.

The Op Code field, (Sheet 9), contains the encoded instruction to be performed. Its outputs are decoded by the hardware and presented as address to the Decoder Read Only Memory. Of the possible 256 combinations 96 are defined as legal instructions and have unique entry points in the micro-program. The remaining 160 combinations are directed by either the hardware or the firmware to the illegal instruction entry point in the micro-program, address X'008'.

The YD field is defined as the user destination field. YD selects one of the sixteen General Registers, in the Processor, in which the result of the user instruction is to be stored. This portion of the IR (Sheet 21) is arranged as an up/down counter. If YDP1 is specified as either the source or destination of a micro-instruction, the YD field of the IR is incremented by one at the end of the instruction. Likewise, if YDM1 is specified, YD is decremented by one.

YS is the user source field of the instruction being emulated. The second operand of the instruction is contained in the General Register specified by YS for RR format instructions. This field also contains the number of the General Register being used as the index register on an RX or an RS instruction or the actual hexadecimal number in a short form instruction. Refer to User's Manual, Publication Number 29-261, for instruction format information.

5.5.4 Arithmetic Register. The Arithmetic Register (AR) (Sheet 23) is used to hold the second operand of the Add, Subtract, OR, AND, or Exclusive OR micro-instructions. The AR may be loaded from the S Bus when it is specified as the destination of a micro-instruction and its outputs form the 'B' inputs to the ALU for all micro-instructions except a Command, as long as NO AR (NA) is not specified. In the case of the Load micro-instruction, even though the information is present at the B inputs to the ALU, this input is ignored.

5.5.5 Flag Register and Condition Code. The Flag Register (FLR) (Sheet 21) is a four bit register which contains the Carry Flag (C), the Overflow Flag (V), the Greater Than Flag (G), and the Less Than Flag (L). The outputs from the FLR are copied into another four bit register, the Condition Code, at the end of each user instruction being emulated. These flags represent results of instructions not otherwise indicated.

The FLR is loaded from the S Bus whenever either the FLR or the Program Status Word (PSW) register is specified as a destination. The contents are copied into the Condition Code on an Instruction Read (see Figure 10) or on a Load micro-instruction if JAM CC is specified. The outputs from the Flag Register are also used by the Branch Circuit (Sheet 8) for conditional branches. The contents of the CC are copied onto the B Bus Bits 12:15) when the PSW is specified as the source register.

The following conditions also modify the FLR:

1. Carry Flag - The C-flag changes on any Arithmetic, Boolean, or Load (except Load Immediate or Load I/O) micro-instruction if carry out is specified. It sets if B Bus Bit 0 is set on a Shift Left, if B Bus Bit 15 is set on a Shift Right, if Carry Save (CSV1) from the ALU is set on an Add, or if CSV1 is inactive on a Subtract. For all other cases the C Flag is reset.
2. Overflow Flag - The V-flag is direct set if false sync is detected on an I/O operation and is changed on any Add or Subtract micro-instruction if No Flags (NF) is not specified. The V flag is set on an Add if the sign of the number on the B Bus is positive and the sign of the B Bus is the same as the sign of the A Bus (Arithmetic Register) and the resulting sign (S Bus) is negative or the number on the B Bus is negative and the sign of the B Bus is again the same as the sign of the A Bus and the result is positive. This flag is also set on a subtract operation if the sign of the B Bus is positive and the signs of the B Bus and A Bus differ and the result sign is negative and the B and A Bus signs differ and the result is positive. For all other combinations of A, B, and S Bus signs on Adds and Subtracts, the V-flag becomes reset. The following Boolean expression also defines the setting of the V flag:

$$\begin{aligned}
 V = & \text{ADD} \cdot \overline{B000} \cdot \overline{(B000 \oplus GA000)} \cdot S000 \\
 & + \text{ADD} \cdot B000 \cdot \overline{(B000 \oplus GA000)} \cdot S000 \\
 & + \text{SUB} \cdot \overline{B000} \cdot (B000 \oplus GA000) \cdot S000 \\
 & + \text{SUB} \cdot B000 \cdot (B000 \oplus GA000) \cdot S000
 \end{aligned}$$

3. Greater Than and Less Than - These flags change on any Arithmetic or Boolean micro-instruction as long as NF is not specified. The G-flag is set if the result of the operation (S Bus) is positive or if the result is zero and either the G or L flag was set from a previous operation. The L flag is set if the resulting sign is negative. Either flag is reset if these conditions are not met.

5.5.6 Register Stack. The Register Stack shown on Sheet 25 consists of 20 16-bit registers, 16 of which are the General Registers specified by the YD and YS fields of the IR. The remaining four registers are defined as PSW, LOC, MR0, and MR1 and are collectively called Micro-Registers. These registers are loaded from the S Bus and are unloaded onto the B Bus.

The register stack consists of 20 19-041 four-bit by four-word register files arranged in a four by five array. Each IC has a read enable and two read select lines, and a write enable and two write select lines. This allows a stack register to be used as both a source and destination in the same micro-instruction. Each enable line selects a group of four registers in the array and the select lines select one register of the group that is enabled. Since the contents of the CC register are gated onto the B Bus if PSW is specified as the source by the micro-program, only the first three ICs in the array are selected for this special case.

The source and destination decoding for the General Register portion of the stack is located on Sheet 24 and micro-stack decoding is found on Sheet 6. Refer to the truth table on Sheet 25 for word selection information.

5.6 Shifter and Latch

The Shifter/Latch circuit (Sheet 22) takes the data on the B Bus, manipulates that data and stores it (when CLK1 is active) prior to presenting it to the A inputs of the ALU. The shifter can load, shift left, shift right, or cross shift the B Bus data. The function performed is determined by the state of the A and B inputs to the eight shifter ICs. A truth table defining these inputs is provided on Sheet 20. The 19-073 ICs which comprise the shifter are tri-state devices. When the S inputs to the shifter are at a logical ZERO level, the chips are enabled and the specified function is performed. If these inputs are high, the outputs of the shifter are disabled and assume a high impedance state.

The cross coupled flip-flops at the output of each state of the shifter latch the data on the Gated B Bus (GB000-150) during the time that CLK1 is active. This prevents the data, which may be changing on the B Bus at this time, from being felt at the inputs to the ALU when CLK1 is active.

5.7 Arithmetic Logic Unit (ALU)

The Arithmetic Logic Unit (ALU) consists of four 19-039 four-bit ALU packs and one 19-040 Carry Look-Ahead pack. The ALU is shown on Sheet 23.

FUNCTION	M	S ₀	S ₁	S ₂	S ₃
LOAD	1	1	1	1	1
AND	1	0	1	1	1
OR	1	1	1	0	1
XOR	1	1	0	0	1
ADD	0	1	0	0	1
SUB	0	0	1	1	0
CMD	0	1	0	0	1

Each 19-038 ALU pack develops four-bits of the low active S Bus. The internal Carry Propagated (CP) from the most significant stage of the ALU pack and the Carry Generated (CG) for the most significant stage (CPXX1 and CGXX1) are applied to the 19-040 Carry Look-Ahead pack to develop the Carry into the next more significant ALU pack (CNXX1). Only the carry output of the most significant ALU chip is used (CSV1) (23C9). Each function of the ALU that is used is described in the following paragraphs. All gate references are to the arbitrary labels on Figure 11. The mnemonics indicated are the actual symbols used as reference on the ICs (23D6).

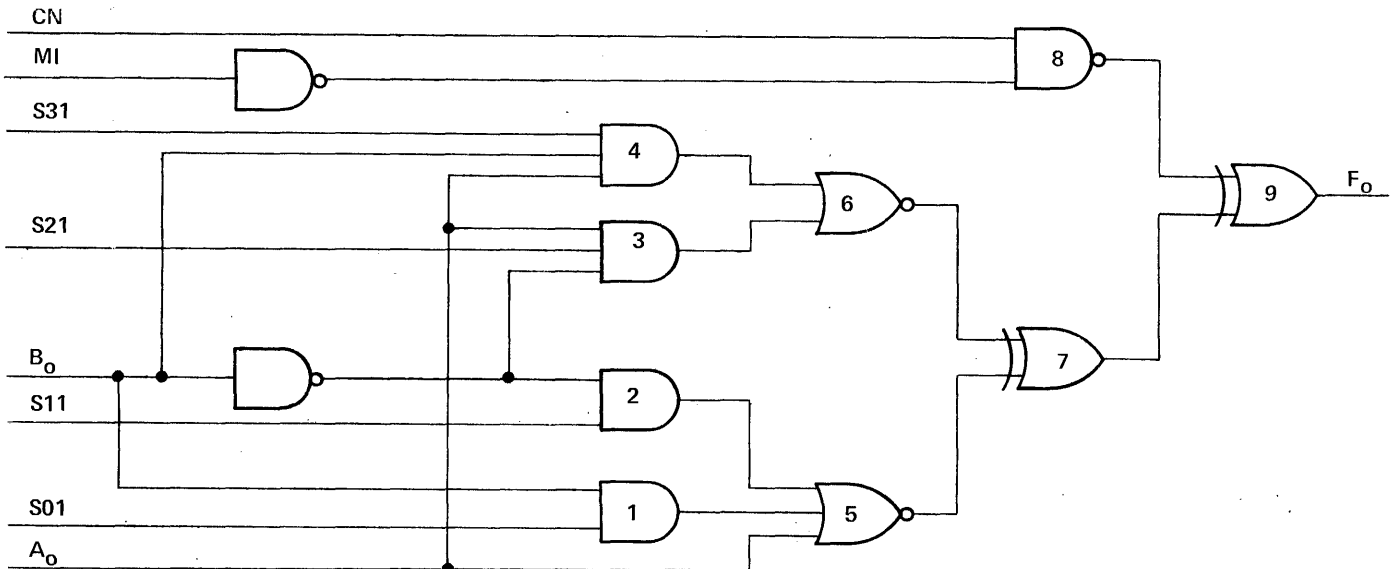

Figure 11. Least Significant ALU Stage

This information is proprietary and is supplied by INTERDATA for the sole purpose of using and maintaining INTERDATA supplied equipment and shall not be used for any other purpose unless specifically authorized in writing.

5.7.1 Load. The ALU is conditioned to the Load mode on any Load micro-instruction. In this mode, Gates 1, 2, 3, and 4 are enabled by S01, S11, S21, and S31 respectively, and Gate 8 is disabled by M1. Since both Gates 1 and 2 are enabled, at least one of their outputs are high producing a low at the output from Gate 5. The state of Gate 6 is the inverse of Ao. If Ao is Low, the output of Gate 7 is high and the output of Gate 8 is Low (\overline{Fo}). For Ao high, the inverse is true at each stage causing \overline{Fo} to also be high. Therefore, in this mode, the state of \overline{Fo} is the same as the state of Ao independent of the Bo input. The state of the Gated B Bus is passed, unmodified, to the S Bus.

5.7.2 AND. The AND function produced by the AND micro-instruction conditions the ALU to logically AND each bit of the Gated B Bus with the gated outputs of the AR. In this mode the output equation for Gate 5 is $(Bo \cdot Ao)$ and the output equation for Gate 6 is (Ao) . The simplified expression for the output from Gate 7 is then $(Ao \cdot Bo)$. Since Gate 8 is disabled by the M1 input to the ALU, its output is high causing the output from Gate 9 to be defined by the same equation as the output from Gate 7, the AND function.

5.7.3 OR. The OR micro-instruction causes each bit from the B Bus to be logically ORed with the corresponding bit from the gated output of the AR. Gate 5 produces a low because of the complimentary Bo inputs. The output equation for Gates 6 and 7 is $(Ao + Bo)$ which corresponds to the \overline{Fo} output from Gate 9.

5.7.4 Exclusive OR. The Exclusive OR micro-instruction produces a logical low at the S Bus if the corresponding bits on the Gated B Bus and the gated outputs of the AR are at different logic levels. The expressions for the outputs from Gates 5 and 6 are $(Ao \cdot Bo)$ and $(AoBo)$ respectively. The function of the output from Gate 7 is; therefore, $Ao\overline{Bo} + \overline{Ao}Bo$, the Exclusive OR function. Since, once again, the output from Gate 8 is high, \overline{Fo} is the same as the output from Gate 7.

5.7.5 Add. The ALU is conditioned to the Add mode on either a command or an Add micro-instruction. Note that with the exception of the M1 control line, Add is the same as Exclusive OR. The M1 control line enables the carry network internal to the ALU device so that the output from Gate 8 is CN. \overline{Fo} now becomes $CN(AoBo + Ao\overline{Bo}) + CN(\overline{Ao}Bo + \overline{Ao}\overline{Bo})$. Figure 11 shows only the least significant stage of the 19-039 four bit ALU. The next three stages are identical except for the internally propagated carry.

5.7.6 Subtract. The Subtract function produced by the four-bit ALU device is A-B-1. For this reason, the carry in to the least significant stage is inverted by the Exclusive OR gate (23B3) on a Subtract micro-instruction. The output equation for Gate 5 is $(Ao \cdot Bo)$ and the equation for Gate 6 is $(Ao + Bo)$. Gate 7 produces a high output when the equation $(Ao \cdot Bo + AoBo)$ is satisfied. The output function, $\overline{Fo} = CN(AoBo + Ao\overline{Bo}) + CN(\overline{Ao}Bo + \overline{Ao}\overline{Bo})$, yields A-B.

5.8 I/O Control

An I/O operation is initiated if I/O is the Source or Destination of a Load micro-instruction. The I/O control logic is shown on Sheet 10. If I/O is a source, then an input operation is initiated if I/O is a destination, an output operation is indicated. I/O timing is discussed separately for input and output.

5.8.1 Input. Refer to Figure 12 for input timing information.

When I/O is specified as a source, IO IN (IO11) (10G2) is decoded. On the trailing edge of the next clock, the Control In flip-flop sets, enabling the specified control line. The zero output of the Control In flip-flop is inverted to generate ULDI01 (11D9) which gates the D Bus onto the B Bus for presenting the data to the specified Destination Register. On the receipt of SYN0 (10C1) or the detection of False Sync, the Sync flip-flop sets, allowing the Control In flip-flop to reset. This disables the active Control Line, causes the device to raise the Sync Line, and allows the resetting of the SYNC flip-flop. The I/O operation is now complete and a new micro-instruction can be executed.

5.8.2 Output. An I/O out is very similar to the input operation except that the two micro-instructions are required for completion of the operation. The first instruction activates the I/O Out (IOO1) line (10G2) but does not specify a Control Line. The first step generates a Stop I/O (STPIO0) (10J5) if the SYNC flip-flop is still set from a previous operation. If the Sync flip-flop is reset, the next micro-instruction is performed. This micro-instruction, besides generating IOO1, specifies a control line which activates CONT1 (10G2). CONT1 and IOO1 gate the data from the S Bus to the D Bus, LDI01 active. On the next clock the Control Out flip-flop sets and the specified control line goes active. The output operation now progresses in the same manner as the IO IN discussed above. Refer to Figure 13 for this timing information.

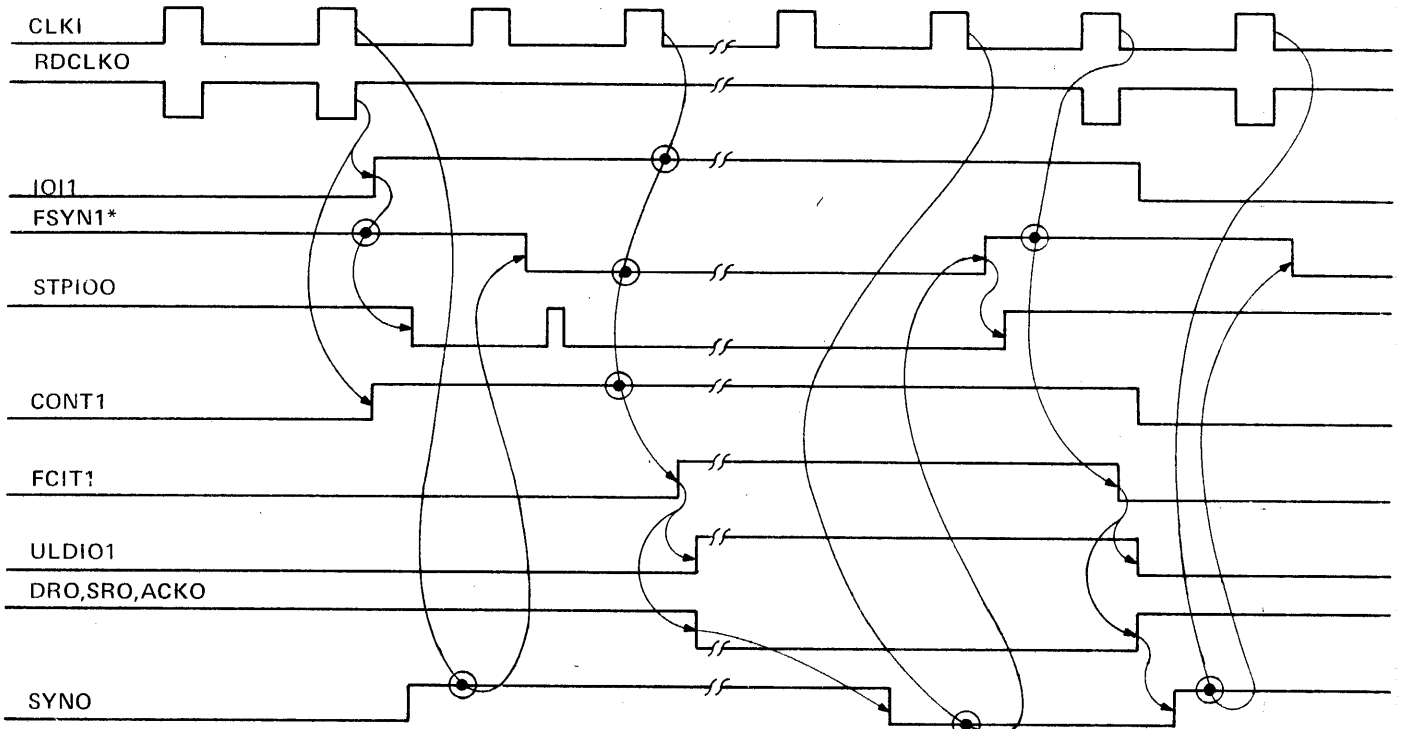

* THE SYNC FLIP-FLOP IS SHOWN SET FROM A PREVIOUS I/O OPERATION

Figure 12. I/O IN

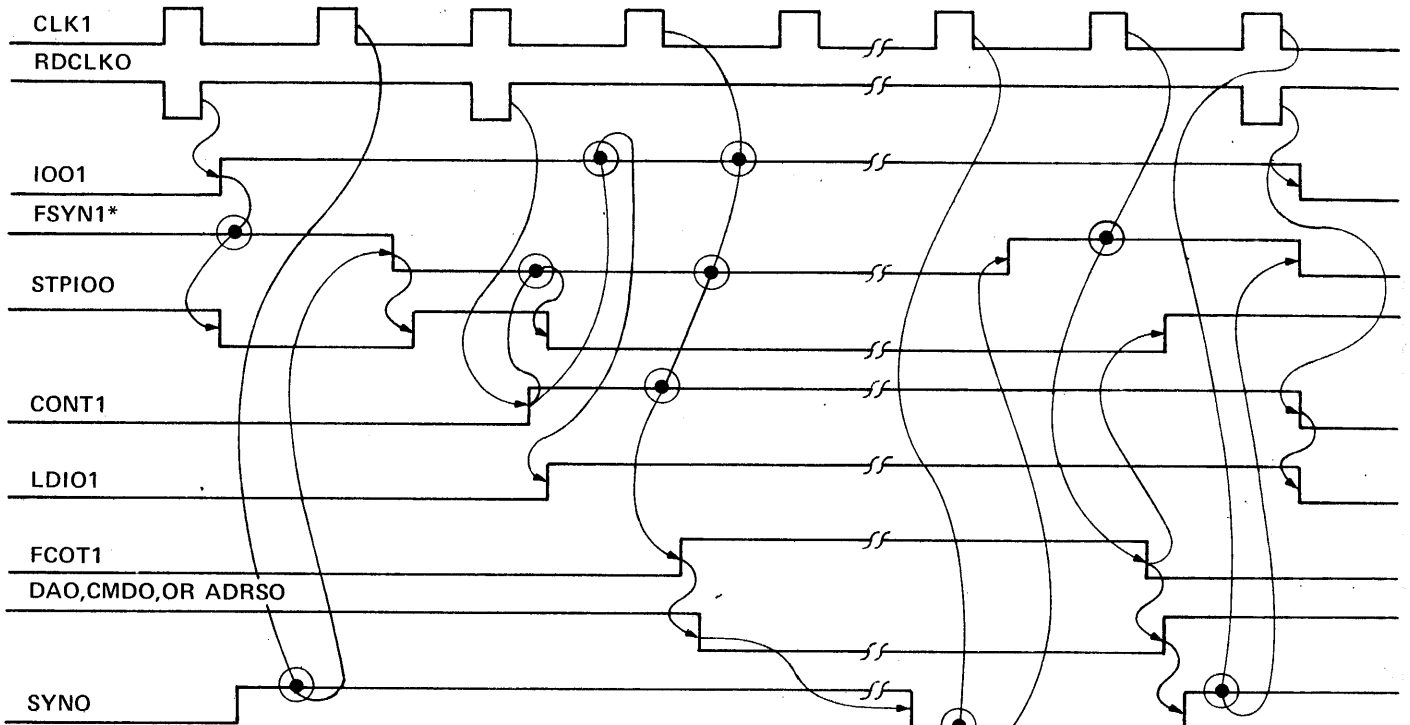

* THE SYNC FLIP-FLOP IS SHOWN INITIALLY SET FROM A PREVIOUS I/O OPERATION

Figure 13. I/O OUT

This information is proprietary and is supplied by INTERDATA for the sole purpose of using and maintaining INTERDATA supplied equipment and shall not be used for any other purpose unless specifically authorized in writing.

5.9 Memory Control and Timing

The memory control logic in the Processor is found on Sheet 14 of the schematics. Refer to Figure 14 for Memory Control and Timing information.

All memory operations, both Processor and DMA, are initiated by activating SF11 (14K4). This function triggers the One Shot (15E1) which starts the memory timing and in addition enables the setting of the F11 flip-flop (14K5) and the Memory Busy (BSY) flip-flop (14J5). The F11 flip-flop is set for one system clock (250 ns) only. It is used to clear the MDR on a read operation and to copy the memory address from the MAR to the MAS. If a memory read was indicated by the micro-program, the Read flip-flop sets on the same clock that set the F11 and BSY flip-flops. The Read flip-flop is set for two clocks and is used to indicate Data Unavailable, generate MSTOP0 (13F3) if the MDR is specified as a source when the flip-flop is set, and to enable the loading of the MDR from the Memory Strobed Data Lines (MS000-160). For Processor initiated memory cycles, the Processor Memory Busy (PBSY) (14S5) flip-flop is set as well as the BSY flip-flop. This function prevents the loading of the MDR (MSTOP0) and its trailing edge sets the Parity Fail flip-flop (17M5) if the parity option is installed and a parity error is detected. Both Busy indications are reset on the third system clock.

If a device interfaced to the DMA port of the Processor requests a memory cycle, REQ0 (14M1) becomes active. This causes the EN0 flip-flop (14L5) to become set. When EN0 is active and the memory is not busy, the Processor Select flip-flop (14H5) and the EN0 flip-flop reset, initiating a memory cycle.

The logic for generating the memory timing is shown on Sheet 12. Its outputs are presented to the memory in the Model 7/16 system. The initiation of a memory cycle is described above and the timing is shown in Figure 14.

5.10 Display System

The Display System provides, if the Hexadecimal Display Panel is present, a means for reading the contents of all the system registers and any core memory location, together with the capability of manually entering data and programs. Figure 15 shows the Hexadecimal Display Panel layout. Within the Hexadecimal Display Panel are five eight-bit byte Display Registers, D1 through D5, that hold data output from the Processor, and a 20-bit Switch Register which stores data input from the Hexadecimal Keyboard.

Associated with each Display Register D1 through D4 are eight indicator lamps that provide a binary read-out and two optional hexadecimal read-out indicators. Associated with Display Register 5 are four indicator lamps for binary display and one optional hexadecimal read-out indicator.

The most significant four bits of Display Register D5 (Bits 0:3) control four of the five indicator lamps along the left edge of the Hexadecimal Display Panel. The fifth indicator lamp is controlled by logic internal to the Hexadecimal Display Panel. To the right of each of these five lamps is a diagram that defines what is being displayed. In general, only one of the diagram lamps is on at a time. If none of the diagram lamps are on, a user program has written data to the display registers.

The most significant 20-bits of the display show the contents of Display Registers D3 and D4 and the least significant four bits of Display Register D5 (Bits 4:7) or the contents of the 20-bit Switch Register. When the Switch Register is being displayed, the lamp next to the Switch Register diagram is illuminated. Any other diagram lamp that may have been on, remains on. When the Switch Register is no longer displayed, its diagram lamp goes out and the most significant 20-bits of the display again shows the contents of Display Registers D3 and D4 and the least significant four bits of Display Register D5 (Bits 4:7).

The Key Operated Security Lock is a three-position, OFF-ON-LOCK, key-operated locking switch, which controls the primary power to the system. This switch can also disable the Hexadecimal Display Panel, thereby preventing any accidental manual input to the system. The power indicator lamp (PWR) associated with the key lock is located in the lower right corner of the Hexadecimal Display Panel. The PWR lamp is on when the key lock is in the ON or LOCK position. The relationship between the key lock switch positions, primary power, the Control keys, and the Hexadecimal keys is:

OFF	The primary power is OFF.
ON	The primary power is ON and the Control keys and Hexadecimal keys are enabled.
LOCK	The primary power is ON and the Control keys and Hexadecimal keys are disabled.

The Hexadecimal Display Panel operating procedures may be found in the appropriate User's Manual.

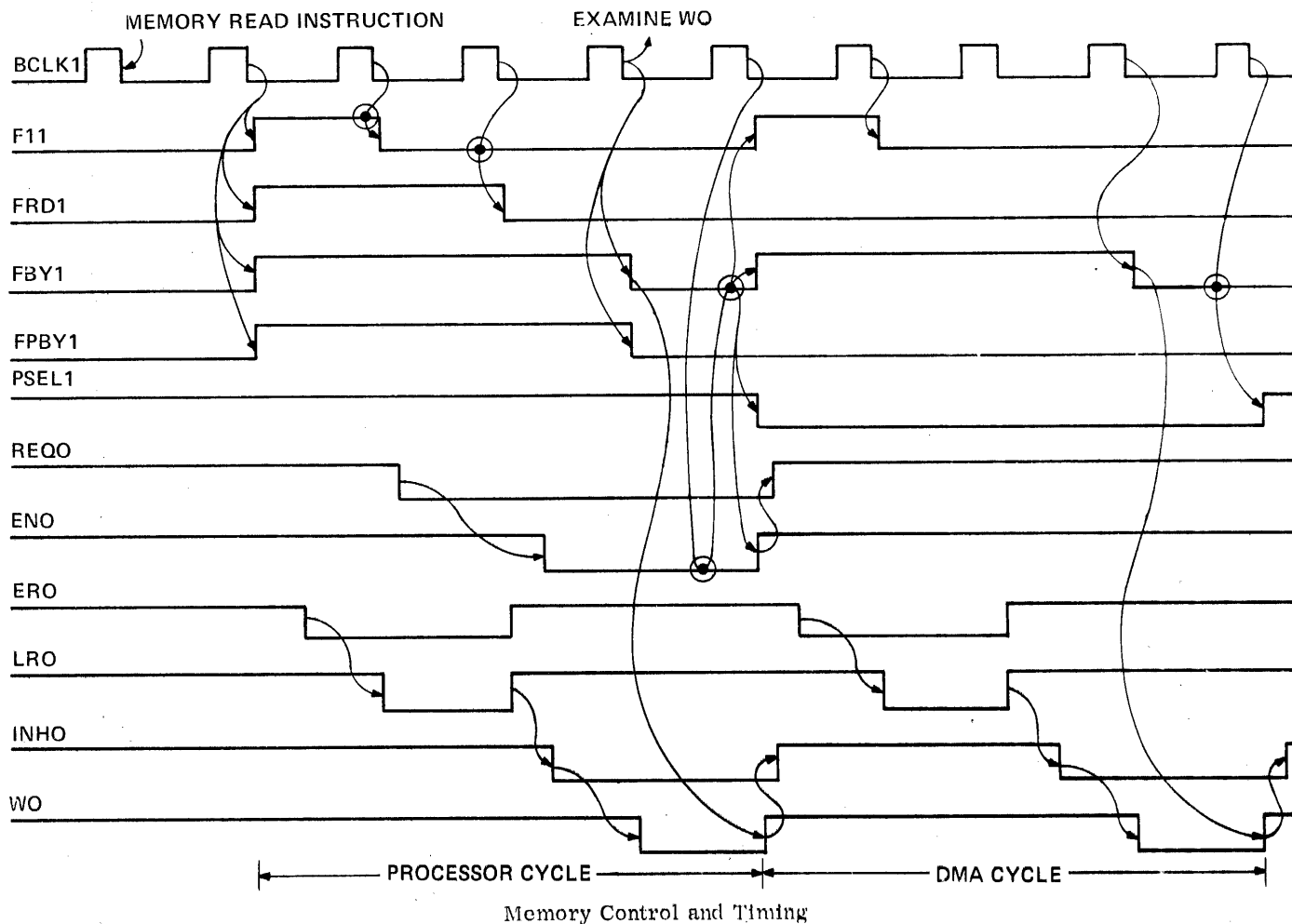

Memory Control and Timing

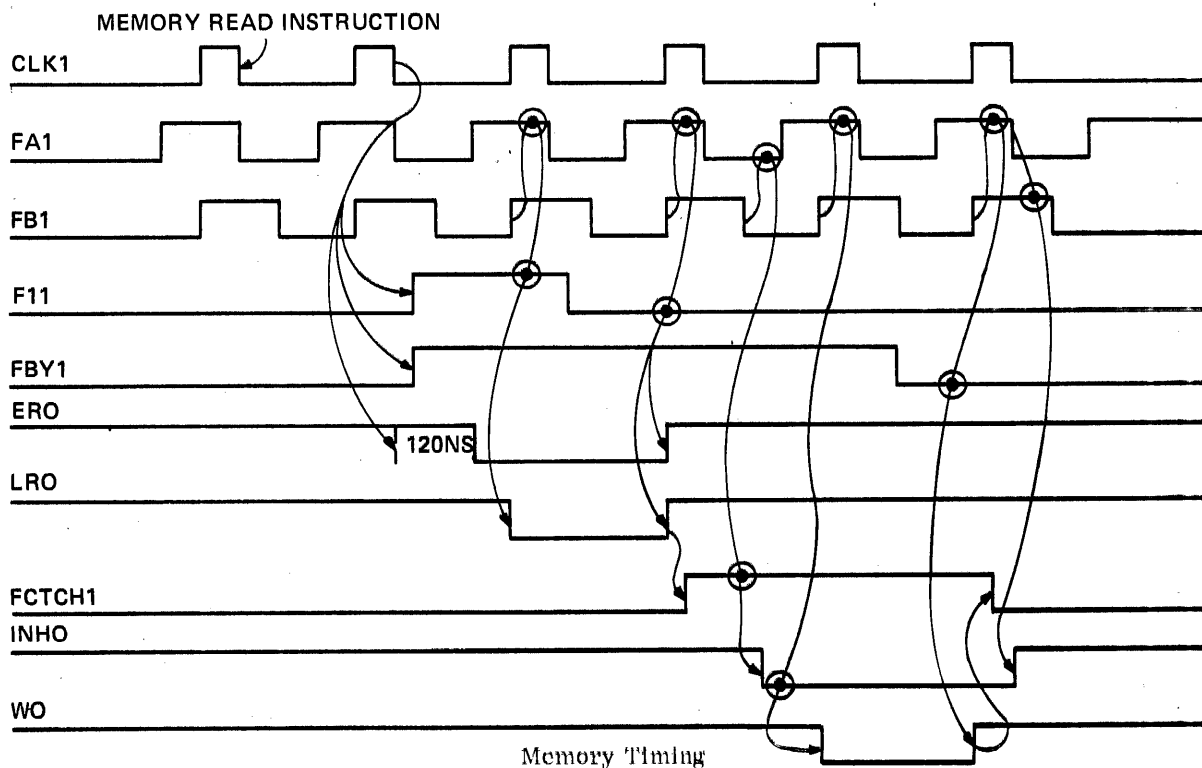

Memory Timing

Figure 14. Memory Control and Timing

This information is proprietary and is supplied by INTERDATA for the sole purpose of using and maintaining INTERDATA supplied equipment and shall not be used for any other purpose unless specifically authorized in writing.

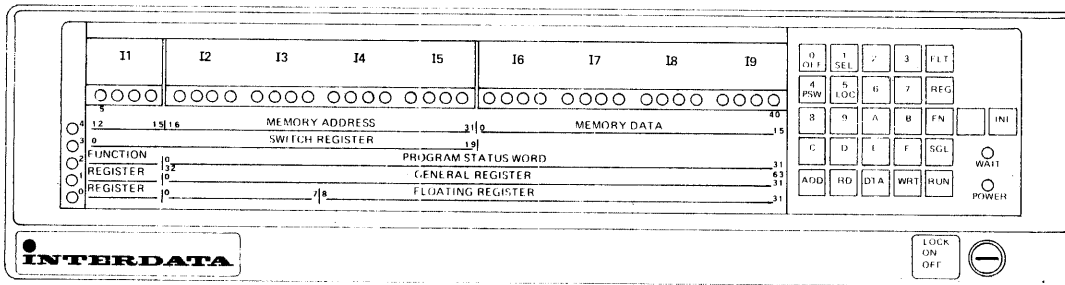

Figure 15. Hexadecimal Display Panel

The Display Controller, built into the Processor, is shown on Sheet 26. Unlike most I/O controllers, data transfer does not take place over the D Bus. Data from the Hexadecimal Display Panel is gated directly to the B Bus, B08:14, and the content of the S Bus, S08:15, is gated by DAG1 and sent to the Hexadecimal Display Panel. Data is transmitted between the Hexadecimal Display Panel and the Display Controller one byte at a time.

5.10.1 Data Transfer. When the display is in the Normal mode, all data outputs are directed into Display Register D1. Conditioning the controller to the Incremental mode, via an Output command, causes the four bit counter (26H7) to be incremented at the trailing edge of DAG1. This counter directs the one-out-of-ten decoder (26H8) to activate LA0, in response to the first DAG1 and then IB0 for all subsequent DAG1's until the counter is initialized. In this mode, the first DA loads Display Register D1, the next DA loads Display Register D2. The next two DAs load Display Registers D3 and D4. This counter is initialized by SCLR0, by an Output command placing the controller in the Incremental mode, or whenever the display is addressed and the Normal mode is selected.

Input data from the Switch Register on the Hexadecimal Display Panel is handled in a similar manner as output data. In the Normal mode or on the first Data Request, (DR), if in the Incremental mode, Switch Register Bits 12:19 are read. The second DR, in the Incremental mode, reads Switch Register Bits 4:11. The two bit counter (26H5) directs the DR to the appropriate group of Switch Registers. This counter is initialized by the same function as the four bit counter discussed above and is incremented at the trailing edge of DRG1.

NOTE

Bits 0:3 are gated out as part of the status byte when address is read.

5.10.2 Control Logic. When the display requires micro-program support, it generates two outputs, ESNO0 and ESNC0, which are latched in the RS flip-flop at 26C2. The output of this flip-flop sets the Console Attention flip-flop (CATN) at 26F1. This flip-flop is reset by GADR0 when the Processor addresses the display.

When the SGL function switch is depressed, SSGL1 becomes active (26A3) and ESNC0 and ESNO0 are generated which caused the Single flip-flop (26G3) to become set. This flip-flop remains set until another execute is generated and the SGL function is not selected.

5.10.3 Status Input. The status byte encoding is shown in Table 7. The status byte is gated onto the SD00:07 lines by the SRG0 lead. SRG0 gates the SD00:07 lines onto Bits 08:15 of the B Bus.

This information is proprietary and is supplied by INTERDATA for the sole purpose of using and maintaining INTERDATA supplied equipment and shall not be used for any other purpose unless specifically authorized in writing.

TABLE 7. DISPLAY STATUS AND COMMAND ENCODING

		STATUS							
		0	1	2	3	4	5	6	7
Run	X	0	0	0	X	X	X	X	
Memory Write	X	0	0	1	X	X	X	X	
Memory Read	X	0	1	0	X	X	X	X	
Address	X	0	1	1	X	X	X	X	
Fixed Register	X	1	0	0	X	X	X	X	} Single or Halt
Floating Register	X	1	0	1	X	X	X	X	
Function	X	1	0	0	X	X	X	X	

General Register	0	1	2	3	4	5	6	7	8	9	A	B	C	D	E	F	Floating Register
0	0	X	X	X	1	0	0	0	0								0
1	1	X	X	X	1	0	0	0									2
2	0	X	X	X	1	0	0	1									4
3	1	X	X	X	1	0	0	1									6
4	0	X	X	X	1	0	1	0									8
5	1	X	X	X	1	0	1	0									A
6	0	X	X	X	1	0	1	1									C
7	1	X	X	X	1	0	1	1									E
8	0	X	X	X	1	1	0	0									
9	1	X	X	X	1	1	0	0									
A	0	X	X	X	1	1	0	1									
B	1	X	X	X	1	1	0	1									
C	0	X	X	X	1	1	1	0									
D	1	X	X	X	1	1	1	0									
E	0	X	X	X	1	1	1	1									
F	1	X	X	X	1	1	1	1									

Function	0	1	2	3	4	5	6	7	8	9	A	B	C	D	E	F
0	0	X	X	X	0	0	0	0								
1	1	X	X	X	0	0	0	0								
2	0	X	X	X	0	0	0	1								
3	1	X	X	X	0	0	0	1								
4	0	X	X	X	0	0	1	0								
5	1	X	X	X	0	0	1	0								
6	0	X	X	X	0	0	1	1								
7	1	X	X	X	0	0	1	1								
8	0	X	X	X	0	1	0	0								
9	1	X	X	X	0	1	0	0								
A	0	X	X	X	0	1	0	1								
B	1	X	X	X	0	1	0	1								
C	0	X	X	X	0	1	1	0								
D	1	X	X	X	0	1	1	0								
E	0	X	X	X	0	1	1	1								
F	1	X	X	X	0	1	1	1								

		COMMAND							
		1	0	0	0	0	0	0	0
Normal	1	0	0	0	0	0	0	0	0
Incremental	0	1	0	0	0	0	0	0	0

This information is proprietary and is supplied by INTERDATA for the sole purpose of using and maintaining INTERDATA supplied equipment and shall not be used for any other purpose unless specifically authorized in writing.

5.11 Basic Switch Control Panel (Figure 16)

Refer to Functional Schematic 02-272B08. The Basic Switch Control Panel provides a means by which a program, previously loaded into memory, can be executed without the aid of the optional Control Console.

This panel provides a means of controlling the system power, initializing the system, and generating a Console Attention (FCATN1) to start program execution, if the Primary Power Fail/Auto Restart option is not installed.

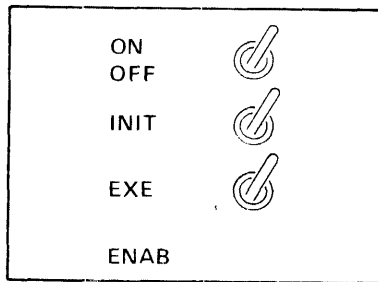

Figure 16. Basic Control Switch Panel

This option conditions the Processor to the Run mode by grounding SSGL1, SD011, SD021, and SD031 at the Control Console connector. The Display Controller, when addressed by the micro-program in the power up sequence, indicates the Run mode. With the Auto-Restart option present, program execution commences at the address specified in the Location Counter (LOC), when the system is turned on and without the Auto-Restart option the micro-program performs a normal power up sequence and then goes to the un-interruptable Idle Loop until the Execute (EXE) switch is operated. When the EXE switch is operated, program execution then begins as above.

6. MAINTENANCE

This section describes maintenance procedures which may be used to check and, if necessary, adjust the Processor.

6.1 Clock Timing

There is only one adjustment associated with the system clocks. The variable capacitor, C1, on the CPU-III mother board, 35-446, is very stable and should not require field adjustment. The adjustment should only be changed after the test indicates that it is out of tolerance and there are no faulty components in the system.

Clock timing is checked, with the use of an oscilloscope, by monitoring CLK1 at the Back Panel Pin 202-1 of either CPU-III or CPU-LO. The period of CLK1 should be 250 nanoseconds. Adjust capacitor C1 to get the 250 nanosecond period. Refer to Section 5.2 of this specification for a description of the clock system.

6.2 Memory Timing Adjustment (Figure 17)

There is only one adjustment associated with the memory timing in the Processor. This adjusts the interval between the fall of CLK1 and the fall of ER0. All other memory timing relationships are under control of the basic Processor clock. Refer back to Figure 14 for memory timing information.

The interval between the fall of CLK1 and the fall of ER0 should be 120 nanoseconds (see Figure 17). This can be tested if the Display Option is installed, by grounding the SCATN0 Test Point on the front edge of CPU-LO. The Control Console rotary function switch should be placed in the Memory Read (MRD) position with the Single (SNG) Switch depressed. For systems without a display panel, this timing relationship can be checked during normal program execution.

Sync may be obtained from the F11 Test Point (F) on CPU-III. Monitor CLK1 (202-1) and ER0 (204-0) on CPU-III and adjust variable resistor, R129, for the proper timing relationship.

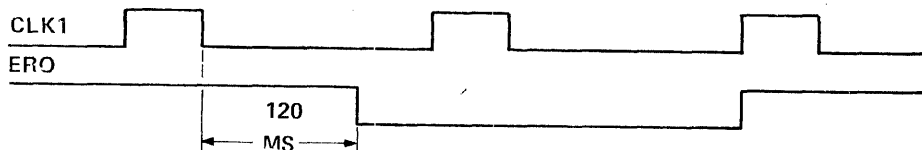

Figure 17. Memory Timing Adjustment

6.3 Overall Processor Test

Use the 06-106 Processor Test Program to perform a comprehensive test of the Processor.

This information is proprietary and is supplied by INTERDATA for the sole purpose of using and maintaining INTERDATA supplied equipment and shall not be used for any other purpose unless specifically authorized in writing.

7. MNEMONICS

The following list provides a brief description of each mnemonic found in the Model 7/16 Processor. The 01-058D08 source of each signal is also provided.

<u>MNEMONIC</u>	<u>MEANING</u>	<u>SCHEMATIC LOCATION</u>
ACK0	Acknowledge Control Line. This signal starts the RACK0/TACK0 daisy chain.	10E9
ADD0	Add micro-instruction decoded.	6M6
ADRS0	Address Control Line.	10F9
ADR1	Output of the Display Controller's Address Latch.	26M7
AMOD1	Address Modification Test Point to the Branch Logic.	21D9
AND0	AND micro-instruction decoded.	6R6
ATN0	Attention Test Line from the I/O Bus.	9A7
BCLK1	Basic Clock. A non-stopable clock used for memory timing and Test Aid control.	14A5
BRAN0	Indicates a true branch was detected.	8R6
BRCH1	Branch. This indicates a branch micro-instruction.	7K7
BRIH1	Indicates a true Branch was detected and RD041 is active.	9R7
BRHL0	Indicates a true Branch was detected and RD041 is inactive.	8H6
B000-150	The B Bus which transmits data from the specified source to the Shifter.	Sheets 5 & 11
CGND0	Ground Reference for system clock, CLK1.	12M2
CGXX1	Carry Generated from the ALU to the look-ahead carry generator.	Sheet 23
CKMDLO	Clock Memory Data Low.	19B4
CKMDHO	Clock Memory Data High.	18B4
CKRD0	The clock used to load the ROM Data Register and increment the ROM Address Register.	13N6
CLFR0	Clear Flag Register.	20C7
CLK1	The major Processor clock from which all other clocks are derived.	12M2
CLMDHO	Clear Memory Data Register High.	14L6
CLMDLO	Clear Memory Data Register Low.	14M6
CLYD0	Clear YD pulse to the YD field of the IR.	7K4
CL070	Control Line 7. This function provides an early power fail indication to devices on the I/O Bus.	10D9
CMD0	Command Control Line.	10F9

<u>MNEMONIC</u>	<u>MEANING</u>	<u>SCHEMATIC LOCATION</u>
CMG1	Command Control Line gated by the Display Controller's Address latch.	26G5
CMND1	Command micro-instruction decoded.	7K2
CONT1	Control Line Enable for I/O operations.	10G3
CPXX1	Carry Propagated from the ALU to the look-ahead carry generator.	Sheet 23
CRYIN0	Carry In to the least significant bit of the ALU.	23A1
CSV0	Carry Save. Carry Out from the ALU.	23D9
CS0	Cross Shift. Conditions the B Bus shifter to perform a Cross Shift.	20B7
DAG0	Data Available Control Line gated by the Display Controller's Address latch.	26G6
DA0	Data Available Control Line.	10E9
DCLK1	Destination Clock. CLK1 gated with DSTOP0.	21D4
DEC0A	Decode. A decode is specified by the micro-program.	9R5
DRG0	Data Request Control Line gated by the Display Controller's Address latch.	26G6
DR0	Data Request Control Line.	10D9
DSTOP0	Destination Stop. Prevents the loading of any destination register when active.	13M4
D000-150	I/O Bus Data Lines.	Sheet 11
ENBY1	Enable Busy. Enables the setting of the Processor Busy flip-flop.	13E4
ENHW0	Enable Halfword line from the DROM.	4A5
ENH1	Enable High. Enables the loading of the Memory Data Register High.	20B7
ENL1	Enable Low. Enables the loading of Memory Data Register Low.	20B7
ENMS0	Enable MS. Gates the contents of the Memory Strobed Data Lines to the MDR on a Read operation.	14K7
EN0	Enable signal to the Direct Memory Access Port.	14M9
ER0	Early Read, used for Read memory timing.	15M2
ESNC0	Execute Switch normally closed contact.	26B1
ESN00	Execute Switch normally open contact.	26B2
EVEN0	Output from the memory parity generator/detector.	17H4
EXDU0	External Data Unavailable. External input which may be used to extend the memory access time beyond .5 microsecond.	14J1
EXMBY0	External Memory Busy. External input which may be used to extend the memory cycle time to more than 1 microsecond.	14J1.

<u>MNEMONIC</u>	<u>MEANING</u>	<u>SCHEMATIC LOCATION</u>
FA1	Output from the Processor Timing flip-flop, state A.	12H1
FBY0	Output from the Memory Busy flip-flop.	14J6
FB1	Output from the Processor timing flip-flop, state B.	12G1
FCATN1	Output from the Console Attention flip-flop indicating a request for console service	26G2
FCIT0	Output from the Control Line In flip-flop.	10E6
FCOT0	Output from the Control Line Out flip-flop.	10F6
FEPF0	Output from the Early Power Fail Relay.	12L4
FER1	Output from the Early Read flip-flop.	15H2
FINCRO	Output from the Display Controller's Incremental mode flip-flop.	26E9
FINH1	Output from the Inhibit flip-flop.	15G5
FINR1	Output from the Instruction Read flip-flop.	21E6
FLGL0	Flag Register Greater Than or Less Than Set.	21S9
FLR1	Output from the Late Read flip-flop.	15H3
FPAR0	Output from the Parity Fail flip-flop.	17N4
FPBY1	Output from the Processor Memory Busy flip-flop.	14S6
FPOW1	The ONE output from the Power Down flip-flop. Set by the micro-program to initialize the system.	7K5
FPSEL1	Output from the Processor Select flip-flop.	14J7
FPSW011	The ONE output from the Program Status Word, Bit 1, Latch.	9J4
FPSW021	The ONE output from the Program Status Word, Bit 2, Latch.	9J5
FRD1	Output from the Memory Read flip-flop.	14N6
FSKIP0	Output from the SKIP flip-flop.	13J8
FSYN0	Output from the SYNC flip-flop.	10C5
FTIT0	Clock Stop signal from the Test Aid.	13B2
FWAIT0	Active when the Processor is in the Wait State.	7K5
FW1	Output from the Write flip-flop.	15H7
F11	Active during the first CLK1 period of a memory operation.	14L6
GARBL0	Gated Arithmetic or Boolean. Arithmetic or Boolean operation gated by No Flags.	21M4
GADR0	Gated Address. Address Control Line gated by the decoded address of the Display Controller.	26A6
GAR0	Gated Arithmetic. Arithmetic operation decoded and gated by No Flags.	21K4

<u>MNEMONIC</u>	<u>MEANING</u>	<u>SCHEMATIC LOCATION</u>
GB000-150	Gated B Bus. The output from the Shifter/Latch circuit to the ALU.	Sheet 22
GCCB1	Gates Condition Code to B Bus.	6F6
GCRY0	Gated Carry. Enables the clock to the Carry Flag.	10L5
GCS0	Gated Cross Shift. Cross Shifted line gated by MAR15.	20E6
GRMS0	Gated Read Micro Stack. Active when PSW is specified as the source register.	6F6
GR00-30	Read Enable to the General Register Stack.	24J8-R8
GW00-30	Write Enable to the General Register Stack.	24B9-24D9
HPARE0	Output from the high 8-bits of the memory parity generator/detector circuit.	17F3
HW0	Halfword I/O test line from the active device.	10G9
ILLE1	Illegal. This indicates that an illegal instruction was detected.	9R3
IMME1	Immediate. Decoded function used on a Load Immediate.	8J9
IMM1	Immediate micro instruction decoded.	6G6
INH0	Inhibit, used for Write memory timing.	15M6
INIT0	Output from the system Initialize Switch.	12B7
IOI1	I/O Input operation decoded.	10G2
IOO1	I/O Out operation decoded.	10G3
IR00-07	The outputs from the op code field of the Instruction Register (IR).	Sheet 9
IR08-15	The outputs from the YD and YS fields of the Instruction Register.	Sheet 21
LAR0	Load Arithmetic Register control line.	6M6
LA0	Load Display Byte A, to Display 2 Bits 8-15.	26H9
LB0	Load Display Byte B, to Display 2 Bits 0-7.	16H9
LCC0	Load Condition Code from Flag Register.	10K5
LC0	Load Display Byte C, to Display 1 Bits 8-15.	26H9
LDFLR0	Load the Flag Register from the S Bus.	9G9
LDIO1	Load I/O. Gates data from S Bus to D Bus.	11B9
LD0	Load Display Byte D, to Display 1 Bits 0-7.	26H9
LD1	A Load micro instruction but not a Load Immediate.	7K8
LIRH0	Load Instruction Register high.	21G9
LMAR0	Load the Memory Address Register from the S Bus.	8L9

<u>MNEMONIC</u>	<u>MEANING</u>	<u>SCHEMATIC LOCATION</u>
LMDR0	Load the Memory Data Register from the S Bus.	19B3
LMDR1	Load the Memory Data Register from the S Bus.	8K4
LOAD0	Any LOAD micro-instruction decoded.	7K6
LRAR0	Load ROM Address Register. Enables the loading of the RAR.	13N7
LR0	Late Read, used for Read memory timing.	15M3
MA000-150	Memory Address Bus to Memory Modules.	Sheet 16
MAR151	Output from the Memory Address Register Bit 15.	16R6
MD000-160	Memory Data Bus to the Memory System.	Sheets 18-19
MDR001-151	Outputs from the Memory Data Register.	Sheets 18-19
MSK0	Mask Test point to Branch Logic.	21H9
MSTOP0	Memory Stop. Stops all clocks except BCLK1 when active.	13J5
MS000-160	Memory Strobed Data Bus from the Memory System.	Sheets 18-19
M1	The M input to the ALU decoded.	20J7
OSC0	Shaped output from the System Clock Oscillator.	12D2
OVAS1	Overflow enable function on an Add or Subtract.	20N7
OVA1	Overflow enable function on an Add.	20L7
OVS1	Overflow enable function on a Subtract.	20N7
PDN1	Power Down. Indicates the start of a power down sequence in the hardware.	12E7
POFF0	Output from the On/Off Power Switch controlling system power.	12B7
POP1	Indicates that a memory operation is specified by the micro program, and that memory cycle is not suppressed by the DROM.	4A5
POWDN0	Power is Down. Resets the SCLR Relay.	12J7
RAR060-150	The outputs from the RAR.	4H1-4H7
RA1	Read Select to the 'A' inputs of the General Register Stack.	24G6
RB1	Read Select to the 'B' inputs of the General Register Stack.	24F6
RD00-19	The outputs from the ROM Data Register.	Sheet 5
REQ0	Request from the Direct Memory Access Port.	14M1
RMS0	Read Micro Stack. Active when either PSW, LOC, MR0 or MR1 is specified as the source.	6G6

<u>MNEMONIC</u>	<u>MEANING</u>	<u>SCHEMATIC LOCATION</u>
RPAR0	Reset Parity. Active on a command Reset Parity by the micro program when attempting to suppress a Machine Malfunction interrupt.	7K3
RSTOP0	ROM Stop. Stops CKRD0 when active.	13J7
SCATN0	Test Point which when grounded generates a constant console Attention indication.	26F1
SCLR0	System Clear. Signal used to initialize the system on a power up or power down.	12A6
SD001-071	Status and Data Bus to the Display Console.	26R1-26R6
SEQ01	S Bus equals zero.	23N7
SFCOT1	Set Control Out flip-flop enable signal.	10G4
SHCRY1	Shifted Carry. Enables the setting of the Carry Flag on either a Shift Right or Shift Left.	21H3
SHI0	Input high Data Switches.	26J6
SHL1	Shift Left. Conditions the B Bus Shifter to shift the data left one place.	20E7
SHR1	Shift Right. Conditions the B Bus Shifter to shift the data right one place.	20F7
SLO0	Input Low Data Switches.	26J6
SNGL1	Single. Test Point to the micro program indicating status of the Control Console.	26G3
SRA060-150	The Set ROM Address lines to the RAR.	4D6-4D9
SRD000-150	The outputs from the ROM used to load the ROM Data Register.	4S2-4S7
SRG0	Status Request Control Line gated by the Display Controller's Address latch.	26E4
SR0	Status Request Control Line.	10D9
STPIO0	Clock Stop signal for I/O operations.	10J5
STPRD0	Stop RD. Test point which when grounded prevents incrementing the ROM Address Register.	13J6
SV0	Set Overflow flag. Direct sets the Overflow flag when False Sync is detected.	10B1
S000-150	S Bus. Outputs from the ALU.	
S01	The S0 input to the ALU decoded.	20K7
S11	The S1 input to the ALU decoded.	20J7
S20	The S2 input to the ALU decoded.	20K7
S31	The S3 input to the ALU decoded.	6N6
TBRAN0	True Branch. Stops CKRD0 when active.	13G7
TEN1	Toggle EN0. Used to toggle the EN0 flip-flop.	14E6

<u>MNEMONIC</u>	<u>MEANING</u>	<u>SCHEMATIC LOCATION</u>
ULAR1	Unload Arithmetic Register to the ALU.	20G7
ULDIO1	Unload I/O. Gates data from D Bus to B Bus.	11E9
UMAR0	Unload the Memory Address Register to the B Bus.	8K9
UMDR0	Unload the Memory Data Register to the B Bus.	8J9
VT	Memory sense amplifier threshold voltage.	14E8
WAIT1	Controls the state of the Wait indicator on the Control Console.	26K4
WA1	Write Select to the 'A' inputs of the General Register Stack.	24F6
WB1	Write Select to the 'B' inputs of the General Register Stack.	24E6
WMS0	Write Micro Stack. Active when either PSW, LOC, MR0 or MR1 is the destination.	6C6
W0	Write, used for Write memory timing.	15M7
YDEST0	Active when either YD or YS is specified as the destination.	6B6
YDM1	YD Minus one. Decrement YD.	6K6
YDP1	YD Plus one. Increment YD.	6J6
YDS0	YD is specified as the source register.	6J6
YSS0	YS is specified as the source register.	6H6
YS0	Active when either YD or YS is specified as a source.	6B6

SELECTOR CHANNEL



M70-103

NS SELECTOR CHANNEL

INSTALLATION SPECIFICATION

1. INTRODUCTION

This specification provides the necessary information for the installation of the 02-232 Selector Channel (SELCH) (Product Number M70-103) in a Model 70, 74, 80, 7/16 or 7/16 HSALU Processor System. The NS Selector Channel is complete on one 35-391M02 printed circuit board.

2. PHYSICAL CHARACTERISTICS

- 2.1 Dimensions 15 3/8 x 14 7/8"
- 2.2 Weight 2 1/2 pounds maximum

3. INSTALLATION

The NS SELCH may be installed in any even numbered universal expansion slot (i.e., 0, 2, 4, or 6) in the Central Processor Unit (CPU) or in the first memory-I/O expansion chassis. See Figure 1. On 7/16 HSALU the NS SELCH may only be installed in Slot 0 of the CPU back panel.

To install a NS Selector Channel on a Model 74 or a 7/16 BASIC, the Selector Channel must be a 35-391M02. To install a Selector Channel on a 7/16 HSALU the Selector Channel must be a 35-391M02, R02 or higher.

NOTE

A SELCH may be installed in slots 0, 1, or 2 of a Model 80/85 CPU chassis only. In this case cutting of the multiplexor bus is not necessary.

3.1 Back Panel Wiring

3.1.1 Multiplexor Channel Bus. At the time of installation it is necessary to cut the Multiplexor Bus wiring between the even numbered slot accepting the SELCH and the next higher numbered slot on the One (1) connector only. The RACK0/TACK0 daisy chain wiring on the back panel is rerouted according to Figure 1. The lower numbered card slots in the chassis become part of the private SELCH Bus on the One (1) connector only.

For the convenience of cutting the Multiplexor Bus, the connections between every other slot are made using "top" wire wraps. (This refers to wire wrap back panels only.) This allows the cutting of the bus by simply lifting the top wraps when the SELCH is installed in an even numbered slot. Refer to Figure 1 A during the following example.

To install a SELCH in Slot 4:

1. Remove all wires on Connector One (1), between Slots 4 and 5, on Pins 11 through 26, Rows 1 and 2. (See backpanel map in 02-232M01D08 Sheet 7.)
2. Remove the wire between 222-0001 and 122-0700.
3. Remove the RACK0/TACK0 jumper between Pins 122 and 222 on both the Zero (0) and One (1) connectors of Slot 4.
4. Connect 122-0700 to 222-0501.
5. Install the SELCH into Slot 4 of the chassis. The private SELCH Bus now appears on the Connector One (1) side of Slots 4, 3, 2, 1, and 0. All slots on the Connector Zero (0) side and Slots 7, 6, and 5 on Connector One (1) side remain as standard Multiplexor Bus slots.

To install a SELCH in any other even numbered slot of a CPU chassis or a Memory-I/O chassis, a similar procedure is followed. Refer to Figure 1 B, C, D, and E.

NOTE: THE CIRCLED NUMBERS ON ILLUSTRATIONS A, B, AND C REFER TO THE CORRESPONDING NUMBERS IN THE FOLLOWING INSTALLATION PROCEDURES.

TO INSTALL A SELECTOR CHANNEL IN SLOT 4 OF THE MEMORY I/O CHASSIS _____

- ① CUT THE MULTIPLEXOR BUS BY REMOVING THE TOP WRAPS.
- ② JUMPER RACKO/TACKO AS SHOWN, REMOVE DASHED JUMPER.
- ③ THIS SECTION BECOMES THE PRIVATE SELECTOR BUS ON THE CONNECTOR ONE (CONN.1) SIDE ONLY. ALL SLOTS ON THE CONNECTOR ZERO (CONN.0) SIDE, AND SLOTS 7, 6 AND 5 ON CONNECTOR ONE SIDE REMAIN AS STANDARD MULTIPLEXOR BUS SLOTS.
- ④ IF REQUIRED, EXTEND THE SELECTOR CHANNEL BUS TO OTHER CHASSIS BY INSTALLING A CABLE HERE.
- ⑤ EXTEND THE MULTIPLEXOR BUS TO OTHER CHASSIS BY INSTALLING A CABLE HERE.
- ⑥ MEMORY MODULE 7, IF IT EXISTS, MUST BE LOCATED IN SLOT 3.

TO INSTALL A SELECTOR CHANNEL IN SLOT 2 OF THE CPU CHASSIS _____

- ① CUT THE MULTIPLEXOR BUS BY REMOVING THE TOP WRAPS.
- ② JUMPER RACKO/TACKO AS SHOWN, REMOVE DASHED JUMPER.
- ③ THIS SECTION BECOMES THE PRIVATE SELECTOR BUS ON THE CONNECTOR ONE (CONN.1) SIDE ONLY. ALL SLOTS ON THE CONNECTOR ZERO (CONN.0) SIDE REMAIN AS STANDARD MULTIPLEXOR BUS SLOTS.
- ④ IF REQUIRED, EXTEND THE SELECTOR CHANNEL BUS TO OTHER CHASSIS BY INSTALLING A CABLE HERE.
- ⑤ EXTEND THE MULTIPLEXOR BUS TO OTHER CHASSIS BY INSTALLING A CABLE HERE.

NOTE: 1
IF A MEMORY I/O CHASSIS IS USED IN THE SYSTEM, ANY SELECTOR CHANNELS MUST BE INSTALLED IN THAT CHASSIS.

NOTE: 2
A SELECTOR CHANNEL MAY NOT BE INSTALLED IN SLOT 2 OF THE 7/16 HSALU. SLOT 0 IS THE ONLY SLOT IN WHICH A SELCH MAY BE INSTALLED.

TO INSTALL 4 SELECTOR CHANNELS (IN SLOTS 6, 4, 2 AND 0) OF THE MEMORY I/O CHASSIS _____

- ① CUT THE MULTIPLEXOR BUS IN FOUR PLACES.
- ② JUMPER RACKO/TACKO AS SHOWN, REMOVE DASHED JUMPER.
- ③ EACH SELCH, EXCEPT THE ONE IN SLOT 0, HAS ONE SLOT AVAILABLE ON IT'S PRIVATE BUS. THE PRIVATE BUSES CAN BE EXTENDED TO OTHER CHASSIS BY INSTALLING CABLES IN SLOT POSITIONS 0, 1, 3 AND 5 ON CONNECTOR ONE (CONN.1) SIDE.
- ④ ALL SLOTS ON THE CONNECTOR ZERO (CONN.0) SIDE REMAIN AS THE STANDARD MULTIPLEXOR BUS. THIS BUS CAN BE EXTENDED BY INSTALLING A CABLE HERE.
- ⑤ MEMORY MODULES 5 AND 7, IF THEY EXIST, MUST BE LOCATED IN SLOTS 1 AND 3.

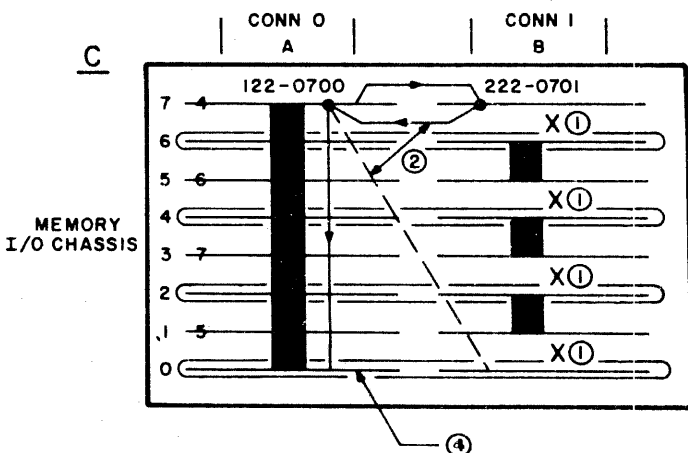
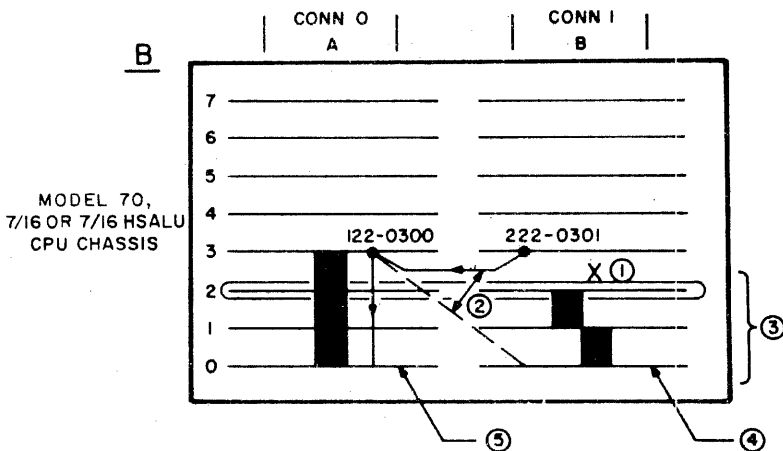
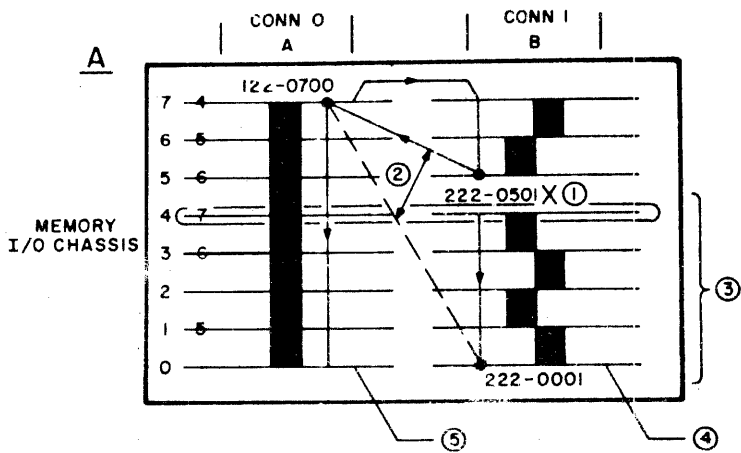
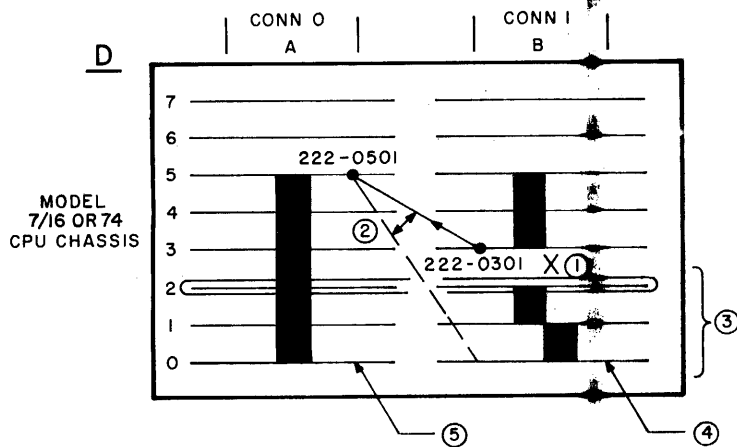

Figure 1. Backpanel Modifications

This information is proprietary and is supplied by INTERDATA for the sole purpose of using and maintaining INTERDATA supplied equipment and shall not be used for any other purpose unless specifically authorized in writing.



TO INSTALL A SELECTOR CHANNEL IN SLOT 2 OF THE CPU CHASSIS—

- ① CUT THE MULTIPLEXOR BUS BY REMOVING THE TOP WRAPS.
- ② JUMPER RACKO/TACKO AS SHOWN, REMOVE DASHED JUMPER.
- ③ THIS SECTION BECOMES THE PRIVATE SELECTOR BUS ON THE CONNECTOR ONE (CONN.1) SIDE ONLY. ALL SLOTS ON THE CONNECTOR ZERO (CONN.0) SIDE REMAIN AS STANDARD MULTIPLEXOR BUS SLOTS.
- ④ IF REQUIRED, EXTEND THE SELECTOR CHANNEL BUS TO OTHER CHASSIS BY INSTALLING A CABLE HERE.
- ⑤ EXTEND THE MULTIPLEXOR BUS TO OTHER CHASSIS BY INSTALLING A CABLE HERE.

NOTE:
IF A MEMORY I/O CHASSIS IS USED IN THE SYSTEM, THE SELECTOR CHANNEL MUST BE IN SLOT 0 OF THE CPU CHASSIS OR IN SOME SLOT OF THE EXPANSION.

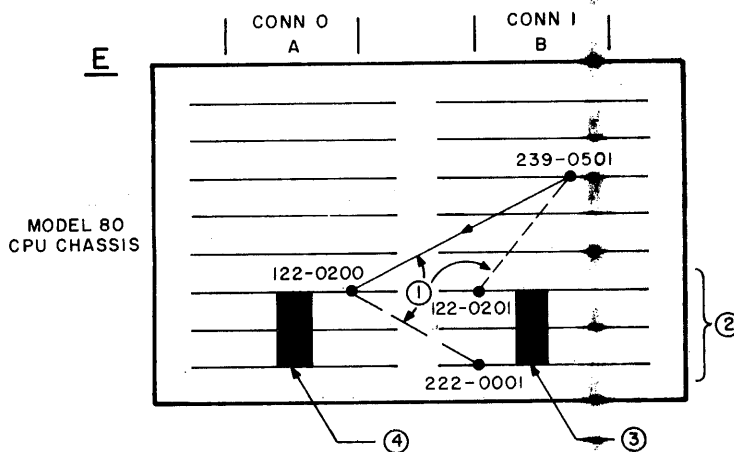

TO INSTALL A SELECTOR CHANNEL IN SLOT 0, 1 OR 2 CHASSIS—

- ① JUMPER RACKO/TACKO AS SHOWN, REMOVE DASHED JUMPERS.
- ② THIS SECTION BECOMES THE PRIVATE SELCH BUS ON THE CONNECTOR ONE (CONN.1) SIDE ONLY. ALL SLOTS ON THE CONNECTOR (CONN.0) SIDE REMAIN AS STANDARD MULTIPLEXOR SLOTS.
- ③ EXTEND THE SELCH BUS TO OTHER CHASSIS BY INSTALLING A CABLE HERE.
- ④ EXTEND THE MULTIPLEXOR BUS TO OTHER CHASSIS BY INSTALLING A CABLE HERE.

NOTES:

1. IF A 17-183 CABLE IS INSTALLED BETWEEN CONNECTORS ZERO AND ONE IN THE CPU CHASSIS, THIS CABLE MUST BE REMOVED PRIOR TO INSTALLING SELCH.
2. THE INSTALLATION OF A SELECTOR CHANNEL OR OTHER I/O DEVICE CONTROLLER IN THE M80 CPU CHASSIS REDUCES THE MAXIMUM MEMORY SIZE BY 16K BYTES (ONE MSU) FOR EACH SLOT USED!
3. ONLY ONE SELECTOR CHANNEL MAY BE CONFIGURED IN THE MODEL 80 PROCESSOR CHASSIS.

Figure 1. Backpanel Modifications
(Continued)

3.1.2 ACT0/TAC0. The ACT0/TAC0 jumper between Pins 137-0 and 237-0 must be removed from the slot used by the SELCH controller. If the Selector Channel is not the first Direct Memory Access (DMA) channel on the Memory Bus, jumper "K" on the SELCH controller must be removed. Note that on a Model 74 only one DMA device is permitted.

NOTE (Not Applicable on Model 74)

On installations with Multiple SELCH's, remove the "EN0" and the "INH0" filters on all but the last SELCH (Remove the following: R70, R72, C59 and C61).

3.2 Cabling

The cabling necessary for the SELCH depends on the system's physical configuration. When the SELCH Bus does not extend outside the chassis, no cabling is required. When the SELCH Bus must be extended to another chassis, a number of cable configurations can be used. See Figure 2. Care should be taken to minimize bus lengths.

See Figure 2 for a summary of cables. Refer also to User's Manual, Publication Number 29-261, for further details on system configurations.

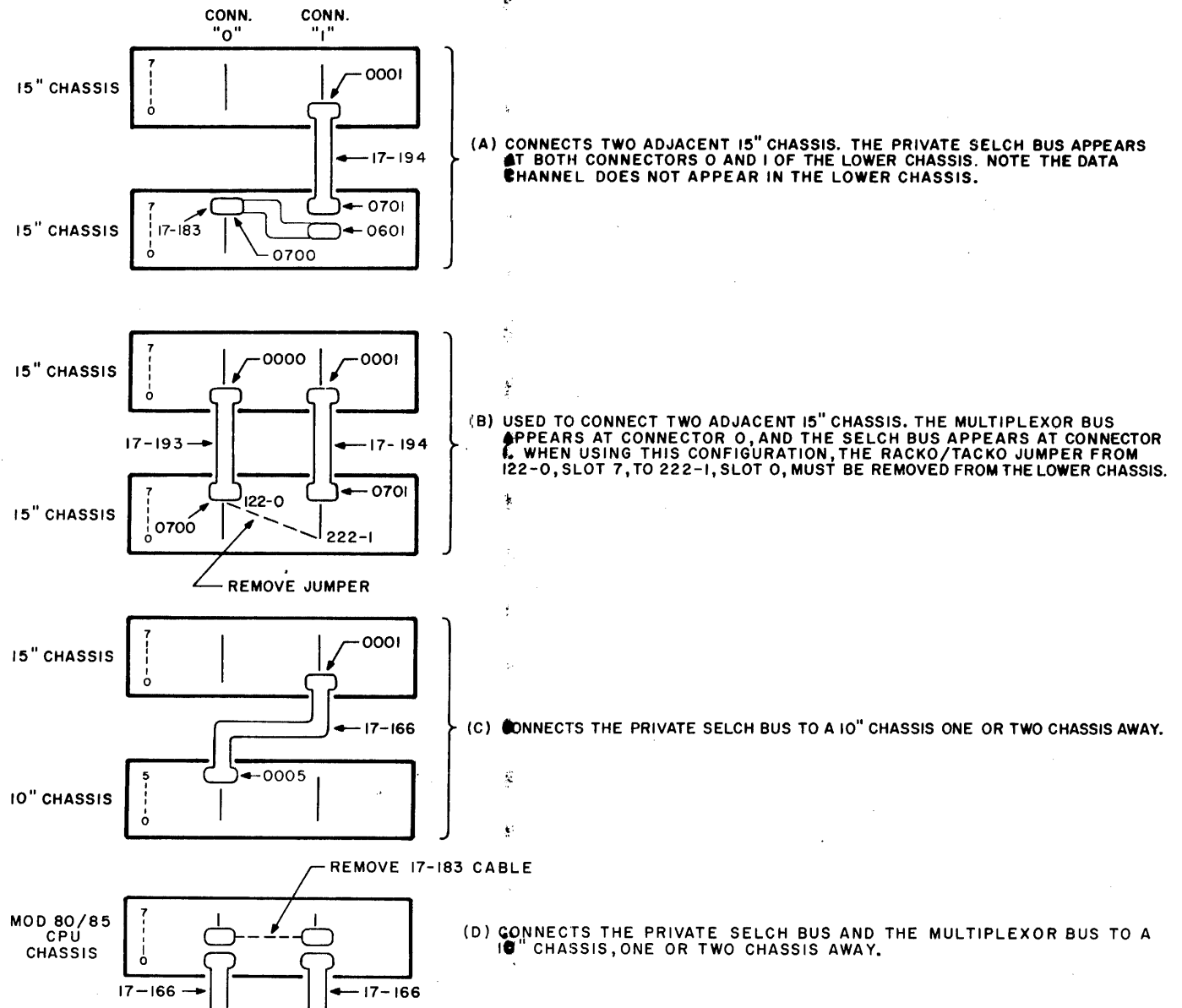

Figure 2. Cabling

4. ADDRESS STRAPPING

The preferred address of the NS Selector Channel is X'F0'. The controller is strapped for this address at the factory. To change the address, refer to Functional Schematic 02-232M01D08. The number and letter designations shown on the schematic refer to the designations on the apparatus side of the SELCH controller board.

5. MODEL 80/85 STRAPPING

For use with the Model 80 or 85 the following options must be exercised:

1. Remove the jumper labeled J located between IC 14 and 15.
2. Change the jumper, above IC 53, from (L to X) to (L to 2).

6. INSTALLATION CHECKS

The NS SELCH is factory tested using a special high speed device. Therefore, field checks are contingent upon the user having appropriate hardware and software available with which to exercise the Selector Channel. When the SELCH is used with Model 80 or 85, insure that the strap options on the SELCH have been made according to Section 5.

NS SELECTOR CHANNEL MAINTENANCE SPECIFICATION

1. INTRODUCTION

The 02-232M01 NS Selector Channel (SELCH) (Product Number M70-103) is a Direct Memory Access port (DMA) which provides block data transfer between a device controller and memory. Once initiated, the transfer is independent of the Processor. The Processor sets up the device controller, loads the SELCH with the starting and final addresses of the memory block, specifies the type of operation (Read or Write), and issues a GO Command. The SELCH then handles the transfer without further direction by the Processor.

The NS Selector Channel is complete on one printed circuit board and occupies one slot in a system chassis. The SELCH provides the drivers, receivers and termination resistors for the private SELCH Bus. This bus originates at Connector One (1) of the SELCH slot and extends to each lower numbered slot in the system chassis on the Connector One (1) side only. The private SELCH Bus can be extended to other chassis, as required. For installation information, refer to Installation Specification 02-232M01A20.

2. SCOPE

This specification describes the operation of the SELCH in its various modes; Setup, Memory Read, Memory Write, and Termination. Where necessary, this specification references the Multiplexor Channel Bus and Memory Bus operations. These buses are described in detail in the User's Manual, Publication Number 29-261.

3. BLOCK DIAGRAM ANALYSIS

Refer to the SELCH block diagram on Sheet 7 of Functional Schematic 02-232M01D08, and the SELCH Flow Chart, Figure 1, during the following analysis. Before initiating a data transfer via the SELCH, the device controller and the SELCH must be set up. The setup procedure is implemented by the Processor via the Multiplexor Bus (MPX-Bus). When the SELCH is in the Idle mode, the MPX-Bus is tied directly to the private SELCH Bus through the SELCH. This allows the Processor to communicate directly with any device on the private SELCH Bus.

To prepare the SELCH for data transfer, the Address Register (AR) and Auxiliary Address Register (AAR) must be loaded with the starting address in memory where the transfer is to begin, and the Final Address Register (FAR) must be loaded with the address of the last memory location to be accessed. These registers are loaded from the eight least significant Data Lines D080:150 by four consecutive Data Availables (DAs) from the Processor. The first two Data Availables simultaneously load the AR and AAR, which are 16-bit incrementing registers. The AR is incremented, by two, after each halfword is transferred to/from memory, and the AAR is incremented, by one, with each byte transferred to/from the device. Data transfer is terminated when the AAR is equal to the FAR or when the AAR increments past its maximum value, X'FFFF'.

Data transfer is begun by the Processor issuing a GO Command to the SELCH. Transfer to/from the device is now independent of the Processor. The GO Command also prevents communication between the Processor and any device on the private SELCH Bus until the transfer is terminated and the SELCH is addressed.

Data transfer is controlled in the Move Data circuit by inspection of the four least significant bits of the Status Byte presented by the active device on the private SELCH Bus. When any one of the three least significant bits are set, (EX, EOM, or DU), the transfer is terminated. Bit-12 (Busy) regulates the rate of data transfer. In the Memory Read mode, the actual data transfer begins with a memory request, REQ0 active, as soon as a GO Command is issued. When the memory request is serviced by the Processor, the SELCH Memory Bus Control circuit activates Select (SEL), which gates the contents of the Address Register (AR) onto the Memory Address Bus, and gates a halfword of data from memory into the Data Register (DR). At the termination of the memory transfer, the data is loaded from the DR to the Data Buffer (DB) and the AR is incremented.

NOTE

Unless the SELCH has dropped REQ0 in time to remain selected during the next memory cycle, the SELCH is deselected by the rising edge of Inhibit (INH0) after the halfword has been transferred.

This information is proprietary and is supplied by INTERDATA for the sole purpose of using and maintaining INTERDATA supplied equipment and shall not be used for any other purpose unless specifically authorized in writing.

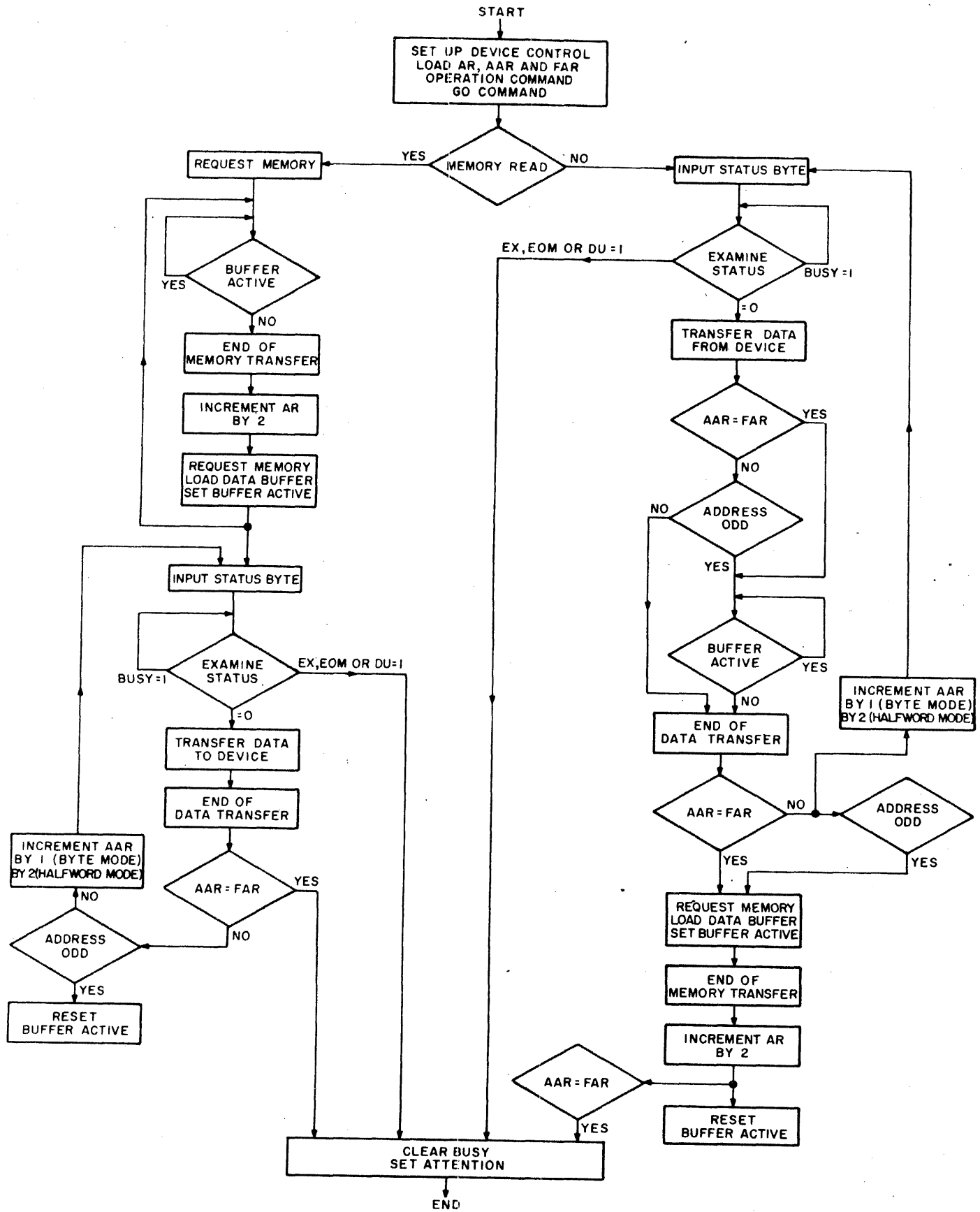

Figure 1. Flow Chart

This information is proprietary and is supplied by INTERDATA for the sole purpose of using and maintaining INTERDATA supplied equipment and shall not be used for any other purpose unless specifically authorized in writing.

Once the DB is loaded, data transfer to the device over Private Data Lines PD000:150 is initiated and, when applicable, a request is made to fetch the next halfword from memory. This cycle continues until either a match is detected between the contents of the Auxiliary Address Register and contents of the Final Address Register, or until the transfer is aborted due to an error condition.

In the Memory Write mode, the data transfer sequence described previously for Memory Read mode is reversed. That is, two bytes of data are loaded into the DR from the device prior to a memory request and the data flow is from the device to the DR, DR to the DB, and finally into memory.

The Branch Gate circuit and the Move Data circuit control the flow of data between memory and the device. The Branch Gate supervises the overall data flow, while the Move Data circuit performs the handshaking between the SELCH and the active device on the private SELCH Bus.

Upon termination of the data transfer, the program is notified via an interrupt and by the inactive state of the SELCH Busy flip-flop which is presented to the program as Bit-12 of the SELCH Status Byte.

Selector Channel Status and Command Byte Data is shown on Table 1.

TABLE 1. SELECTOR CHANNEL STATUS AND COMMAND BYTE DATA

BIT NUMBER	0	1	2	3	4	5	6	7
STATUS BYTE					BSY			
COMMAND BYTE			READ	GO	STOP			

- BSY When this bit is set, a one shot generates the EBS1 pulse to start the appropriate SELCH operation. When this bit is cleared an interrupt is generated.
- READ This command, Bit-2, sets the Memory Write (WT) flip-flop. The controller on the SELCH Bus is setup for a device Read operation.
- GO This command, Bit-3, clears the MSC flip-flop and sets the BSY flip-flop to initiate the Data Transfer mode.
- STOP This command, Bit-4, from the Processor clears the BSY flip-flop and initializes the Load/Unload Sequencer. During the Data Transfer mode, execution of the command is delayed until the end of a memory cycle, if one is in progress.

4. FUNCTIONAL DIAGRAM ANALYSIS

4.1 Introduction

This section relates to Functional Schematic 02-232M01D08, Sheets 1 through 6. Note that in INTERDATA functional schematics, the last character in the mnemonic symbol designates the logic level when the signal is active. For example; D080 is Data Line Number 8 (D08). The last character (0) indicates that when D080 is active, the line is at a logical Zero level.

4.2 SELCH Control Circuit

In the Idle mode, the SELCH Address (2M8), Busy (3F3), and Multiplexor-SELCH (MSC) (3FA) flip-flops are reset and the private SELCH Bus is tied directly to the Multiplexor Bus. This allows the Processor to communicate, via the Multiplexor Bus, with any device on the private SELCH Bus.

To communicate with the SELCH, it must first be addressed. The SELCH Address (X'F0' preferred) is placed on Data Lines D080:150 (1A3-8) and the Address control line is activated (ADRS0)(4B8). The SELCH Address is decoded by the four input NAND gate (1F4) and the Address flip-flop is set (2M8). The set output from the Address flip-flop (AD1)(2J7), when active, prevents the control signals on the MPX-Bus from passing onto the private SELCH Bus by holding the Control Line Gate inactive (CLG1) (1B2). Capacitors C33 and C34 (4D8) delay the propagation of the Private Address control line (PADRS0) (4F9) to the SELCH Bus, so that when the SELCH is being addressed PADRS0 does not become active. This delay allows the SELCH to be addressed without resetting the Address flip-flop of the active device on the private SELCH Bus.

The simultaneous loading of the Address Register (AR) and Auxiliary Address Register (AAR), and the loading of the Final Address Register (FAR) is accomplished by four consecutive Data Availables (DAs) from the Processor. The Load/Unload Sequencer (2L2) controls the loading of these registers (AR, AAR, and FAR) and the unloading of the AAR. The sequencer is set to its initial state by the termination of the last data transfer, a Stop Command, or a System Clear (SCLR0)(4MS) so that the first DA, through Data Available Gate (DAG0)(2L4), will activate Load Address Register High (LARH0)(2S2).

LARH0 gates Data Lines DA081:151 (1D3-8) into the eight most significant bits of the AR and AAR. The rising edge of the first and each successive Data Available Gate (DAG0)(2L4) increments the sequencer and allows the next DA to activate the next load line. The second DA loads the eight least significant bits of these registers. The third and fourth DAs will then load the Final Address Register in the same order. The contents of the AAR may be inspected, via the program, by issuing two Data Requests (DR) to the SELCH whenever the Load/Unload Sequencer is in its initial state. (c.g., Upon termination of a SELCH transfer, sequencer initialized, the FAR may be inspected to determine if the entire block of data had been transferred.)

If a Memory Write operation is desired, an Output Command with Bit-10 set must be issued to set the Write flip-flop (3F5). Since the Write flip-flop is reset by the Data Available/Request Gate (DARG1)(2L5) whenever a DA or DR is sent to the SELCH (setup procedure), no command is necessary to initiate a Memory Read operation.

Data transfer commences with a GO Command from the Processor, which is an Output Command with Bit-11 set. The GO Command sets both the Busy (3F3) and MSC (3F4) flip-flops. The setting of the Busy flip-flop causes an End of Busy Set pulse (EBS1) (3H4) to be generated. This pulse is generated from the falling edge of BSY0 (3F3), and is used by the Branch Gate circuit to initiate the transfer cycle. The Busy latch circuit remains set until the Selector Channel detects the termination of transfer and its state is presented to the program via Bit-12 of the Sense Status Byte.

The MSC flip-flop is reset by SCLR0A or by addressing the SELCH, Set Gate active (SGAD1)(2L9), when the Busy flip-flop is reset. The resetting of the MSC flip-flop, MSC0 active, clears any pending interrupt in the Selector Channel.

Information is steered from the SELCH to both the Data Lines D080:150 (1B4-9) and the Private Data Lines PD080:150 (1S4-9) by the proper gating of four each, four-to-one line multiplexors (Sheet 1). For example; with the SELCH idle, Busy reset, all Data Lines are tied directly to the Private Data Lines in both directions.

4.3 Memory Bus Control Circuit

Memory Bus Control timing relationships are shown in Figure 2. A SELCH request for memory is started by activating Set Request (SREQ0)(3S4). SREQ0 is activated by the Branch Gate circuit (3M8) when either the SELCH has received a halfword of data from the device or, in the Memory Read mode, whenever the Memory Data Register is available to accept the next halfword.

SREQ0 is applied to the direct set input of the Request flip-flop (REQ)(4L5) which sets the flip-flop and sends REQ0 to the Processor. When REQ0 is received, the Processor generates Enable (EN0). EN0, on the first DMA device, is jumpered to Accept (ACT0) which generates the daisy chain priority loop through all DMAs in the system. The daisy chain begins at the highest priority DMA as EN0, and propagates to the lower priority DMAs as Transmit Accept (TAC0) until it is captured by the first DMA requesting a memory cycle. When the REQ flip-flop is set and ACT0 (EN0) is active, the ACT0/TAC0 contention circuit (4H2) blocks the propagation of TAC0, and provide highs on the J input to the SEL flip-flop and the K input to the REQ flip-flop. Thus, on the rising edge of EN0, the Select flip-flop becomes set and the Request flip-flop is reset. When the SELCH REQ flip-flop is reset and ACT0 (EN0) is active, the ACT0 signal is propagated as TAC0 to the DMA with a lower priority.

The trailing edge of Inhibit (INH0) (4H5), from the Processor, indicates the end of the memory cycle. This edge, unless the SELCH has dropped REQ0 in time to remain selected during the next cycle, causes the SEL flip-flop to reset. Two pulses, End of Memory Transfer (EMX0) (4M7) and Inhibit (INH0P) (4M2), are generated by the leading and trailing edges of INH0 respectively. EMX0 is used by the Branch Gate circuit to indicate the end of the memory transfer. The Address Register is toggled by the AND function of SEU and INH1.

In the Memory Read mode, the Memory Data Register (MDR) is cleared by Clear Data Register (CDR0) (4R2) which is generated by the trailing edge of REQ1. Write Not (WTOA) (3F5) is ANDed with SEL1 to form Enable Memory Data Read (ENMDR1) (4R6), which gates the contents of the MDR onto the Memory Data Lines MD000:150 (Sheet 6) for the restore portion of the memory cycle. (This function is disabled when using solid state memory.) The contents of the memory location accessed is gated to the direct set inputs of the MDR by Enable Memory Strobe (ENMS1) (4R4). This function is WT•SEL•CDR0 for use with core memory and WT•SEL•INH when using solid state memory (4R4).

When writing to memory, the contents of the Data Buffer is gated onto Memory Data Lines MD000:150 (Sheet 6) by Enable Memory Data Write (ENMDW1)(4R3), when selected. A Memory Write operation is indicated to the Processor by activating WRT0A (4S3).

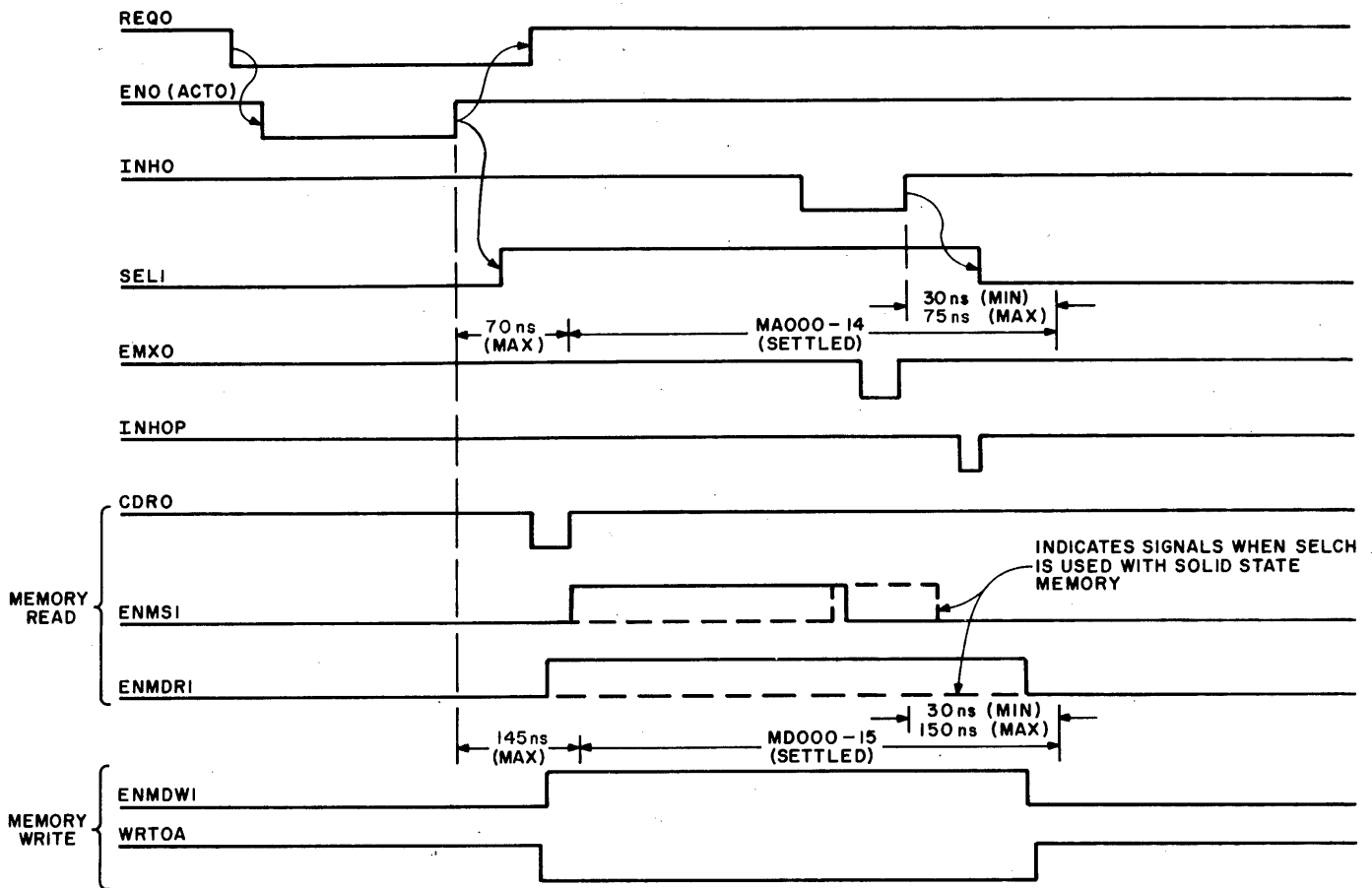

Figure 2. Memory Bus Control Timing Diagram

4.4 Address Register and Auxiliary Address Register.

The Address Register (AR) and Auxiliary Address Register (AAR) (Sheet 5) each consist of four, four-bit counters. These registers are loaded simultaneously by the Processor from Data Lines D080:150 (1A3-8), under control of the Load/Unload Sequencer (as discussed in Section 4.2), with the starting address from which the block transfer is to begin. The contents of the AR (Sheet 5) is gated onto Memory Address Lines MA000:140 (5R1-8) whenever the SELCH is selected, SEL flip-flop set. The AR is incremented with each memory transfer by Select-Inhibit (SINH0) (4K8). The AAR (Sheet 5) keeps track of the transfer between the SELCH and the device. This register is incremented, by one, for each byte of data transferred by Toggle Auxiliary Address Register (TAAR0) (3M1). When the transfer is in the Half-word mode, TAAR0 is generated twice for each transfer. The outputs of the AAR are used by the Match circuit to determine the end of the data block. Its contents may be examined, via the program, by issuing two consecutive DRs to the SELCH when the sequencer is initialized. In addition, AAR151 is used in the Byte Transfer mode to determine whether the byte being transferred is odd or even, for byte steering. Carry Out from the most significant stage of the AAR (CO) (541) terminates the transfer, clear Busy, when a transfer is attempted past the maximum memory address. This feature prevents 'wrap-around' in memory.

4.5 Final Address Register

The Final Address Register (FAR) is implemented by four quad latches (Sheet 5). This register, like AR and AAR, is loaded by the Processor under control of the Load/Unload Sequencer. The outputs of this register are used exclusively by the Match circuit to determine when the final address of the transfer is reached.

4.6 Memory Data Register and Data Buffer

The Memory Data Register (MDR)(Sheet 6) is a 16-bit register composed of 16 edge triggered JK flip-flops. In the Memory Read mode, the MDR is first cleared by Clear Data Register (CDR0) (4R2) and then direct set by each active bit on Memory Strobed Data Lines MS000:150 (Sheet 6). During a Memory Write, the data, in double rail format, present at the J and K inputs to the MDR, is toggled into the flip-flops on the trailing edge of either Load Data Register High (LDRH0)(649) or Load Data Register Low (LDRL0)(6J9).

As soon as the MDR is loaded, if the Data Buffer (DB) is empty (as determined by the inactive state of the Buffer Active flip-flop)(3H1), the MDR contents are loaded into the DB (Sheet 6) by Load Data Buffer (LDB1)(357). Information present in the DB is, in turn, either written into memory via Memory Data Lines MD000:150 or sent to the device on Private Data Lines PD000:150.

4.7 Data Transfer Circuit

Refer to Figure 3 for Memory Read timing diagrams and Figure 4 for Memory Write timing diagrams. The Memory Read timing diagram shows the timing of a three byte transfer, in the Byte mode, of 2,000,000 bytes/second. Figure 4 shows a transfer of two halfwords, in the Halfword mode, to a slower device.

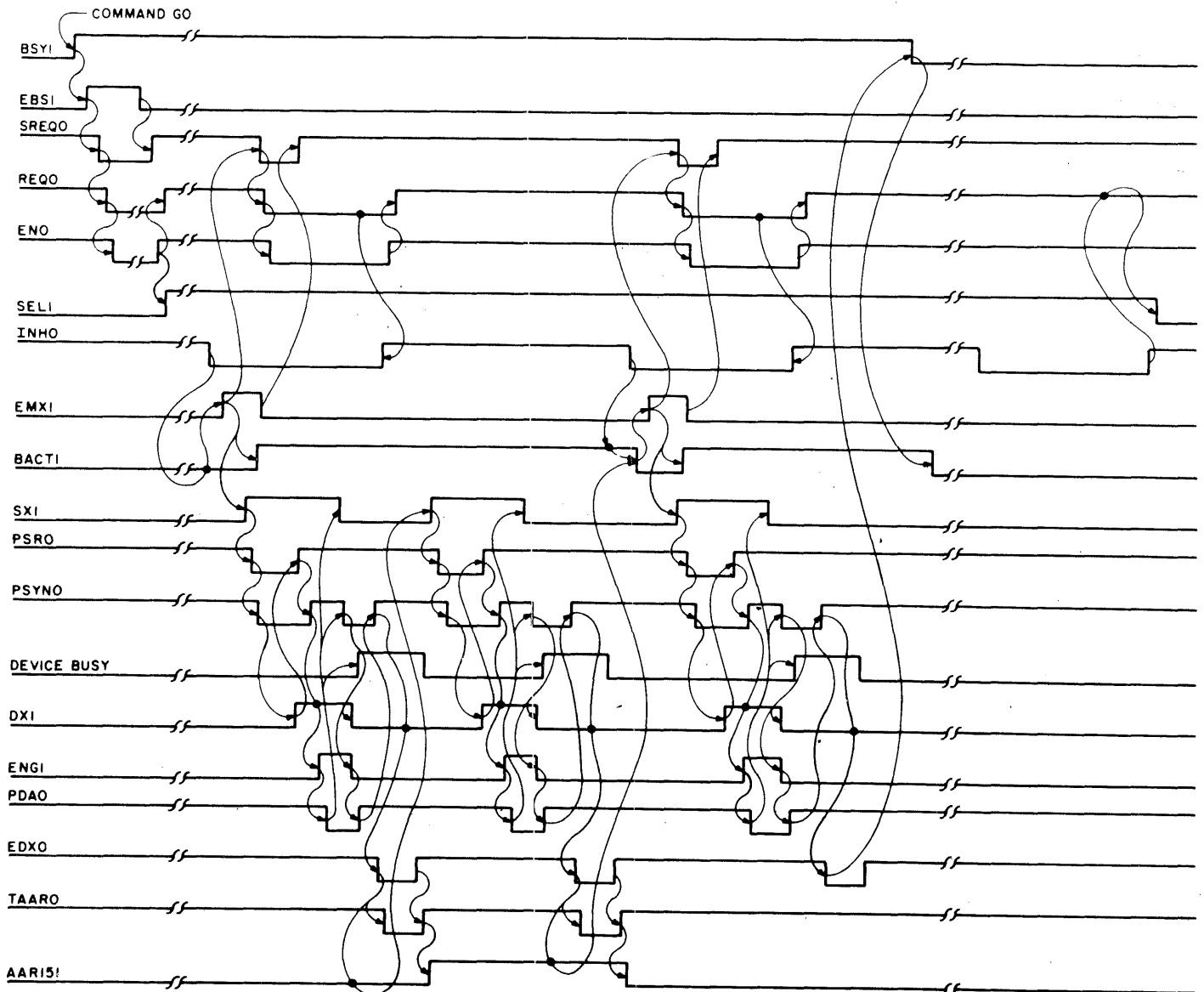

Figure 3. Memory Read (Byte Mode)

This information is proprietary and is supplied by INTERDATA for the sole purpose of using and maintaining INTERDATA supplied equipment and shall not be used for any other purpose unless specifically authorized in writing.

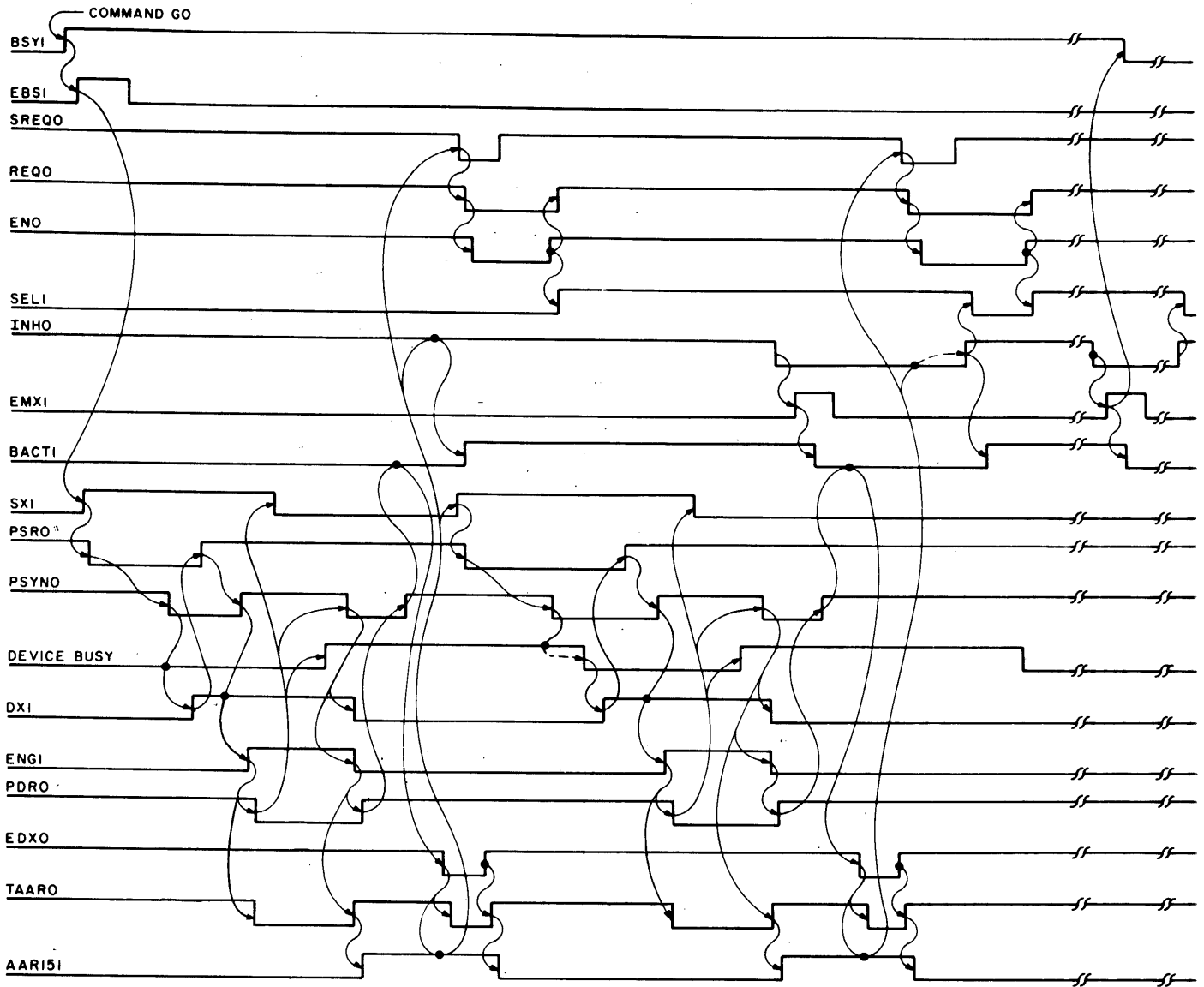

Figure 4. Memory Write (Halfword I/O Mode)

A GO Command to the Selector Channel sets the Busy flip-flop which generates the End of Busy Set pulse (EBS1)(3K8).

In the Memory Read mode, EBS1 is decoded by the Branch Gate circuit and SREQ0 is generated. Thus, a request for memory is initiated. When the halfword of data is present in the MDR, the End of Memory Transfer pulse (EMX1)(4R6) becomes active and the Branch Gate circuit once again requests memory and generates Set Status Transfer (SSX0)(3S5) and Load Data Buffer (LDB1)(3S7). These signals initiate the transfer to the device and load the Data Buffer (DB) respectively.

SSX0 sets the Status Request flip-flop (3F6) which activates the Private Status Request control line (PSR0)(3G6) to the active device on the private SELCH Bus. This Status Request examines the four least significant bits of the Status Byte. If any of the three least significant bits (EX, EOM, or DU) are set, the transfer is terminated by resetting the Busy flip-flop (3F3). The assumption is made that each of these status bits remain reset for the remainder of this discussion. With Bit-12 (Busy) of the Status Byte reset, the Data Transfer flip-flop becomes set (3F7). Data Transfer (DX0)(3E1) inhibits the generation of PSR0, which causes Private Sync (PSYN1)(4B4) from the device to become inactive. This enables Engage to go high (ENGI)(3D8), which allows the Private Data Available control line (PDA0)(3H5) to become active. The Private Data Available/Request signal (PDAR1)(3H5), generated whenever a Private Data Available (PAD0) or Private Data Request (PDR0) signal is active, will then clear the Status Request flip-flop. Upon receipt of Sync from the device, PSYN1 active, the Data Transfer flip-flop becomes reset and ENGI goes low, disabling PAD0. When the Sync is removed by the device, an 80 nanosecond End of Data Transfer pulse is generated (EDX0)(3J8) which increments the Auxiliary Address Register and is used by the Branch Gate circuit to generate a function in accordance with the truth table for EDX on Sheet 3. This cycle continues until termination of the transfer is detected.

In the Memory Write mode, WT1 active (3F5), EBS1 is used to generate SSX0, and the Branch Gate circuit directs the loading of a halfword of data into the DB before a memory request is made. The transfer of data from the device is the same as described in the Memory Read mode, except that ENG1 is used to generate the Private Data Request control line (PDR0)(3H5) rather than PDA0. Data from the device is loaded into the MDR on the trailing edge of either Load Data Register High (LDRH0)(2R2) or Load Data Register Low (LDRL0)(2R2), depending on which eight bits are being loaded. In the Halfword Transfer mode, both LDRH0 and LDRL0 are generated simultaneously. With WT1 active, the generation of EDX1 is delayed by activating the clear input to the one-shot (3H8) when the Buffer Active flip-flop is set (BACT1)(3H1), if either the transfer to the device is on an odd boundary or when a Match is detected (MCH0)(5J2). This prevents the reloading of the Data Buffer (DB) before the last halfword has been written into memory.

4.8 RACK0/TACK0 Contention Circuit

The Selector Channel directs the propagation of the Acknowledge signal to lower priority devices on the Multiplexor Channel Bus as well as devices on the private SELCH Bus. If the Selector Channel Attention flip-flop (4B4) is set, the SELCH captures the Receive Acknowledge signal (RACK0) (4B3), place its device address on the Data Lines and return Sync to the Processor, Attention Sync (ATSYN0)(4F4) active. If the Attention flip-flop is reset, RACK0 is propagated as either Private Transmit Acknowledge (PTACK0)(4F2) or Transmit Acknowledge (TACK0)(4F3). Since devices on the private SELCH Bus have a higher interrupt priority than devices below the SELCH on the MPX Bus; if the Private Attention Test line is active (PATN0) (4B1), PTACK0 is generated rather than TACK0. Note that when MSC0 is high (3F4), PATN0 is disabled so that a device on the private SELCH Bus may not interrupt the Processor while the SELCH is active.

5. MAINTENANCE, TROUBLE SHOOTING, AND TEST

Before attempting any maintenance or testing, insure that the necessary back panel modifications and SELCH board option strapping have been made in accordance with the NS Selector Channel Installation Specification 02-232M01A20.

To insure a 2,000,000 Byte/second transfer rate in the Byte Transfer Mode, it is necessary to limit the maximum delay between PDA0, PDR0, and PSR0 and the return of Sync from the device (PSYN0), to 30 nanoseconds. In addition, the device must be ready for the next byte of data, Busy Status Bit reset, whenever a Status Request is made. Field testing of this device is contingent upon the user having appropriate software and hardware available with which to exercise the Selector Channel. There are no adjustments associated with this device. Do not install Terminator Boards 35-433 or 35-434 on the SELCH bus if a transfer rate of 2,000,000 Bytes/second is to be maintained in the Byte (8 Bit) Mode. The SELCH Bus should be contained on a single 15 inch chassis if no terminators are used.

6. MNEMONICS

The following list provides a brief description of each mnemonic found in the SELCH. The source of each signal on Functional Schematic 02-232M01D08 is also provided.

<u>MNEMONIC</u>	<u>MEANING</u>	<u>SCHEMATIC LOCATION</u>
AAR001:151	Outputs of the Auxiliary Address Register	5F1-5F9
ACT0	Accept - Request for memory accepted by Processor	4H1
AD1	Address - Active when SELCH is addressed	2K7
ADRS0	Address control line from MPX-Bus	4B8
AG081:151	Address Gated Lines - Output of Address Strap	1E3 - 1E8
ATN0	Attention - Attention to Processor	4F1
ATSYN	Attention Sync - Generated by an Acknowledge Attention from Processor	4F4
BACT1	Buffer Active - Indicates that valid data is present in the DB	3H1
BSY	Busy - Indicates a data transfer is in progress	3F3
CDR0	Clear Data Register - Clears MDR prior to loading from MS000:150	4R2
CBSY0	Clear Busy - Terminates transfer when a match is detected	3M3
CL070	Control Line 7 - Control Line from MPX-Bus	4B6
CLG1	Control Line Gate - Gates Private Control Lines	1C2

This information is proprietary and is supplied by INTERDATA for the sole purpose of using and maintaining INTERDATA supplied equipment and shall not be used for any other purpose unless specifically authorized in writing.

<u>MNEMONIC</u>	<u>MEANING</u>	<u>SCHEMATIC LOCATION</u>
CLUSO	Clear Load/Unload Sequencer - Clears Sequencer	3S2
CMD0	Command Control Line from MPX-Bus	4B8
CMG	Command Gated by AD1	2S7
COO	Carry Out of the AAR - Prevents Memory 'Wrap-around'	5A1
D000:150	Data Lines from MPX-Bus	1A3 - 1A8 2A1 - 2A8
DA0	Data Available Control Line from MPX-Bus	4B7
DLG0	Data Line Gate - Gates Data Lines and Private Data Lines	1R2 - 1D3
DB001:151	Outputs of Data Buffer	6G2 - 6G9 6R2 - 6R9
DR0	Data Request Control Line from MPX-Bus	4B7
DRG0	Data Request Gated by AD1	2L5
DX	Data Transfer flip-flop	3F8
EBS1	End of Busy Set - Signals the start of a SELCH transfer	3J4
EDX1	End of Data Transfer - Signals the end of a device transfer	3J8
EMX1	End of Memory Transfer - Signals the end of a memory transfer	4R7
EN0	Enable from Memory Bus	4H2
ENG1	Engage - Gates either PDS0 or PDR0	3D8
ENMDR1	Enable Memory Data Register Read - Gates contents of MDR to MD000:150	4R6
ENMDW1	Enable Memory Data Register Write - Gates contents of DB to MD000:150	4R3
ENMS1	Enable Memory Strobe - Gates contents of MS000:150 to MDR	4R4
HW0	Halfword Control Line from MPX-Bus	1D2
INH0	Inhibit from Memory Bus	4H5
LARH0	Load Address Register High - Loads AAR and AR, Bits 00:07	2R2
LARL0	Load Address Register Low - Loads AAR and AR, Bits 08:15	2R2
LDB1	Load Data Buffer - Load contents of MDR to DB	3S2
LDRH0	Load Data Register High - Loads MDR Bits 00:07	3F8
LDRL0	Load Data Register Low - Loads MDR Bits 08:15	3H9
LFRH0	Load Final Address Register High - Loads FAR Bits 00:07	2S3
LFRL0	Load Final Address Register Low - Loads FAR Bits 08:15	2S3
MA000:140	Memory Address Lines to Memory Bus	5R1 - 5R8
MCH1	Match - Indicates a match between AAR and FAR	5J6

This information is proprietary and is supplied by INTERDATA for the sole purpose of using and maintaining INTERDATA supplied equipment and shall not be used for any other purpose unless specifically authorized in writing.

<u>MNEMONIC</u>	<u>MEANING</u>	<u>SCHEMATIC LOCATION</u>
MD000:150	Memory Data Lines to Memory Bus	6G1 - 6G8 6R1 - 6R8
MS000:150	Memory Strobed Data Lines from Memory Bus	6A1 - 6A8 6H1 - 6H8
MSC0	Multiplexor SELCH Control flip-flop	3F4
PADRS0	Private Address Control Line to SELCH Bus	4F8
PATN0	Private Attention from SELCH Bus	4B1
PCL070	Private Control Line 7 to SELCH Bus	4R6
PCMD0	Private Command Control Line to SELCH Bus	4F8
PD000:150	Private Data Lines - SELCH Bus	2F1 - 2F8 1S3 - 1S9
PDA0	Private Data Available Control Line to SELCH Bus	3H5
PHW0	Private Halfword Control Line from SELCH Bus	1A1
PSR0	Private Status Request Control Line to SELCH Bus	3H6
PSYN0	Private Sync from SELCH Bus	4B5
PTACK0	Private Transmit Acknowledge to SELCH Bus	4F2
RACK0	Receive Acknowledge from MPX-Bus	4B5
RBA0	Reset Buffer Active - Resets Buffer Active flip-flop	3M2
REQ0	Request - Request for memory cycle to Memory Bus	4R5
SCLR0	System Clear - Initialize Signal	4H4
SGAD1	Set Gate - Sets Address flip-flop	2LR
SR0	Status Request Control line from MPX-Bus	4B6
SREQ0	Set Request - Initiates a request for memory	3S4
SSX0	Set Status Transfer - Sets the Status Request flip-flop.	3S5
SX	Status Transfer - Status Request flip-flop	3F6
SYN0	Sync to MPX-Bus	2S5
TAC0	Transmit Accept - To lower priority DMAs	4R1
TACK0	Transmit Acknowledge - To lower priority devices on MPX Bus	4F3
TAAR0	Toggle Auxiliary Address Register - Increments AAR	3M1
TAR0	Toggle Address Register - Increments AR	4S7
UAAH0	Unload Auxiliary Address Register High - Unloads AAR Bits 00:07	2R4
UAARL0	Unload Auxiliary Address Register Low - Unloads AAR Bits 08:15	2R4
VT	Write flip-flop	3F5
VRT0A	Write to Memory Bus, when selected	4R3

This information is proprietary and is supplied by INTERDATA for the sole purpose of using and maintaining INTERDATA supplied equipment and shall not be used for any other purpose unless specifically authorized in writing.

AUTO LOADER



M71-103

AUTOMATIC LOADER

INFORMATION SPECIFICATION

1. INTRODUCTION

The Automatic Loader consists of a logic card connector, cable, and switch panel which connects onto CPU-LO board Connector 3 (Display Connector). The Automatic Loader provides a means of applying power to the Processor via a LOCK/ON/OFF switch, initializing the Processor (INIT), and starting a resident program (EXE). The micro-program in the Processor fetches a device address and a command byte from the Automatic Loader on its power up sequence, when enabled. This information is used to load a program from the specified device.

This information specification covers installation and operation of the Automatic Loader.

2. INSTALLATION

The Automatic Loader is installed on CPU-LO board Connector 3, and to the 25-327 Terminal Strip, Positions C1 and C2. Refer to Figure 1. Prior to installation, the Automatic Loader must be modified to specify the appropriate device number and command byte. The Automatic Loader is initially equipped with a device number of X'FF' and a command of X'FF'. Refer to Functional Schematic 02-325C08 for the information necessary to change the device and command designations.

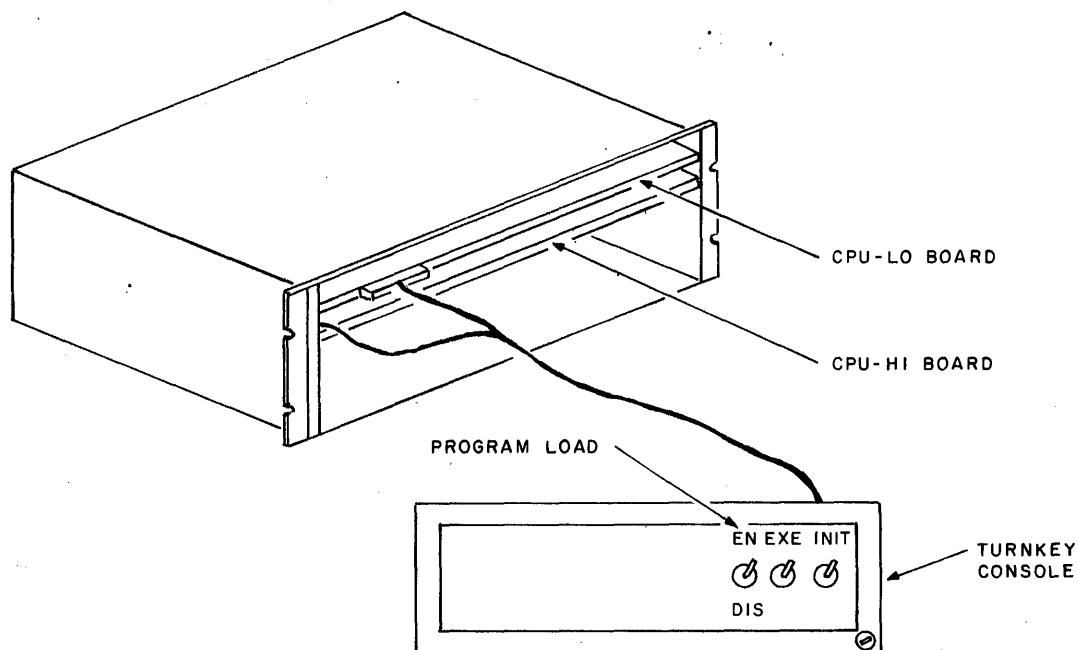

Figure 1. CPU-LO Board Connection

3. OPERATION

Refer to Figure 2 during this description.

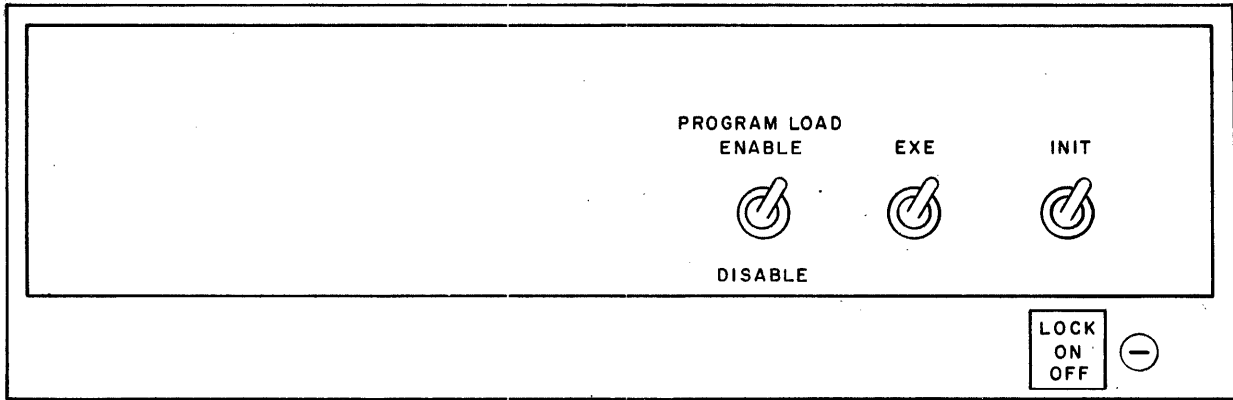

Figure 2. Switch Features

OFF/ON/LOCK

Power switch. This is a three position key operated security lock switch which controls primary power to the system. When placed in the OFF position, the testable Primary Power Fail signal (PPF) goes active which causes a power fail indication and removes the DC voltages to the system. In the ON position, DC power is applied to the Processor. In the LOCK position, the power remains on but the EXE and INIT switches are disabled.

INIT

Initialize switch. The Initialize switch generates the testable PPF signal. The micro-program responds to PPF by saving the Processor status in main memory and then doing a Command Power Down to initialize the system.

EXE

Execute switch. The Execute switch generates the testable Console Attention signal (CATN0). The micro-program always assumes the Run mode in response to the Automatic Loader CATN0 (EXE), except when the Program Load switch is in the Enable position.

PROGRAM LOAD

Program Load switch. The Program Load switch determines whether or not an auto-load is to be performed after the system is initialized or upon power up. If the Program Load switch is in the Enable position, upon initialization or power up, an automatic load is performed from the device number specified by the Automatic Loader logic card.

The micro-program determines that the Automatic Loader option has been selected by the unique status of the display controller; namely a zero in Bit 4 of the status and a one in Bit 7. The state of the Program Load switch is presented to the Processor as Bit 6 of the display status. On power up or initialize, the micro-program determines that the Automatic Loader option is present, then does two data requests from the device number '01' (Automatic Loader). The first data byte received is the device number from which an automatic load is to be performed and the second data byte is an appropriate output command for that device. The device number and command byte are a function of the Automatic Loader logic card.

NOTE

The type device used must be able to respond with data with one Output command. This device must also have a valid status (busy only or all zeros) immediately after the Output command. The first data byte read must be valid data.

Figure 3 shows the data format for automatic loading. This data may be appended to a system program or may be a stand-alone program used as a general purpose boot loader. Appendix 1 is an example of the latter.

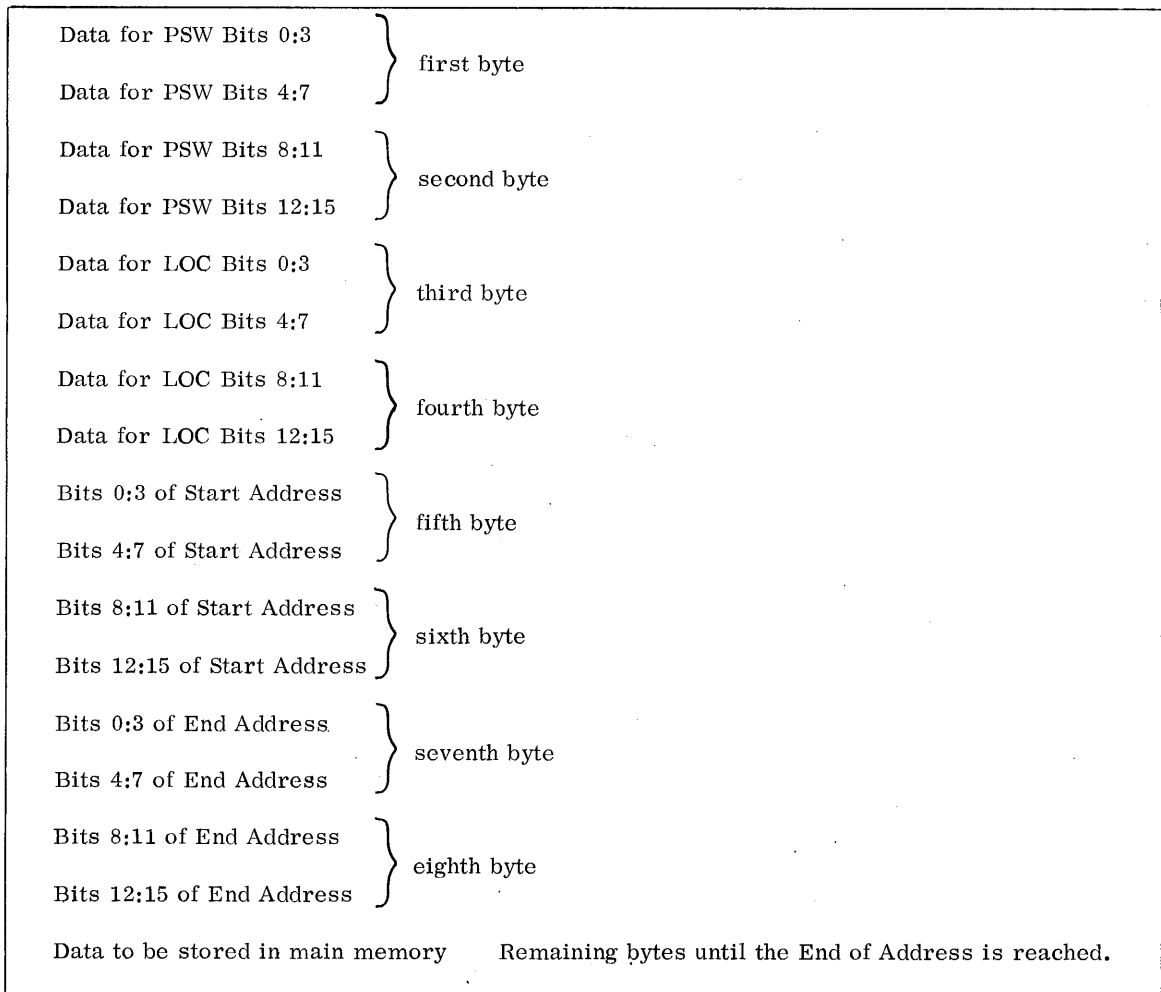

Figure 3. Data Format for Automatic Loading

On the completion of the Auto-Load, the micro-program commences to execute the User program from the Memory Address specified by LOC (third and fourth bytes). Note that if Bit 0 of the PSW, as specified by the first byte, is set, the Processor goes to the "Wait" state. Program execution then begins when the Execute switch is operated.

APPENDIX 1

GENERAL BOOT LOADER PROGRAM

1. PROGRAM DESCRIPTION

The General Boot Loader Program automatically sets the Binary Input Device definition to the device number and command byte associated with the Automatic Loader logic card.

General Boot Loader Program

```
                                ORG  X'0048'  
0048      8000                  DC  X'8000' START  SET WAIT BIT  
004A      0050  
004C      0050                  DC  START,END  
004E      005D  
0050      2401      START      LIS  0,1          SET REGISTER 0  
0052      D900                  RH  0,X'78'      READ DEVNO AND COMMAND  
0054      0078  
0056      D500                  AL  X'CF'        DO AUTO LOAD  
0058      00CF  
005A      4300                  B    X'80'  
005C      0080  
                                END          EQV  *-1
```

The above program places the Processor in the Wait state after loading. When the Execute switch is operated, the device number and command byte associated with the Boot Loader logic card is read into location X'0078', the binary input device specification. Then, the Auto Load instruction is executed.

2. PROGRAM CREATION

The user can prepare an eight bit tape of this program on any INTERDATA Processor equipped with a display panel by loading CLUB (03-013) or an equivalent program; then, key the program into memory. Use the 'Q' directive with limits of X'0048' through X'005D'. (Any program can be used which generates an eight bit tape. Note that the tape must not be punched with a leading X'F0' as occurs with some operating systems when punching eight bit paper tape.)

3. OPERATION PROCEDURES

Use the following procedure to load programs using the General Boot Loader Program.

1. Place the PROGRAM LOAD switch in the ENABLE position.
2. Apply power to the appropriate input device (e.g., Teletype) and place the General Boot Loader tape in the device with the first character over the read station.
3. Turn the Power switch to the ON position.
4. Note that if a Teletype is used as the input device, place the lever on the TTY reader to the "START" position.
5. The Processor reads the tape and then halts. Any program that can be loaded with a standard 50 Sequence, (AL X'CF') can now be loaded.
(B X'80')
6. Place the appropriate paper tape in the Binary Input Device and momentarily depress the EXE switch. The 50 Sequence which was loaded by the Automatic Loader now begins execution.

4. USAGE

Using a Boot Loader Program that establishes the standard 50 Sequence in memory, in general, the following programs can be run on a Model 7/16 with the Automatic Loader option.

1. Any M10 Tape can be loaded immediately after loading the 50 Sequence (i.e., General Loader, Rel Loader, Basic Assembly, BOSS, or DOS object tape).
2. Any M08, M09, M16, or M17 program tape can be loaded with the General Loader or Rel Loader, provided it has an end transfer address (i.e., CLUB, Memory test, or Processor test).
3. Any M14 Tape can be loaded after CLUB has been loaded and executed to modify the 50 Sequence with an appropriate ending address.

APPENDIX 2

ALTERNATE BOOT LOADER PROGRAM

The following listing shows an alternate program designed to be loaded from a TTY. The information loaded comprises a standard '50 Sequence' with device definition table. After loading, the program issues an X-OFF to the TTY to stop the paper tape. Then an asterisk is printed to indicate that the 50 Sequence is in memory and ready. Execution of the 50 Sequence is begun by depressing the Break key on the TTY. This program issues an X-ON to the TTY to start the tape advancing through the reader before the 50 Sequence is begun.

INTERDATA MODEL 7/16 AUTO-BOOT LOADER				PAGE 1
* * * ROUTINE IS AUTOMATICALLY LOADED FROM TTY ON * POWER UP OR INITIALIZE. AFTER LOAD, TTY READER * IS TURNED OFF AND AN ASTERISK IS PRINTED. THE * OPERATOR THEN PLACES GENERAL LOADER OR REL LOADER * PAPER TAPE IN TTY READER. DEPRESS BREAK KEY * ON KEYBOARD TO START AUTOLOAD SEQUENCE. * *				
0008	RET	EQU	8	
0009	STAT	EQU	9	
000A	TTY	EQU	10	
000B	TWRT	EQU	11	
000C	TREAD	EQU	12	
000D	DAT	EQU	13	
000F	OUT	EQU	14	
000F	XON	EQU	15	
* *				
0048		ORG	X'0048'	
* *				
0048	0100	DC	X'0100',START	PSW AND LOC
	0058			
004C	0050	DC	LOAD	START ADDRESS
004E	0093	DC	END	END ADDRESS
* *				
0050	0500	LOAD	AL	X'CF'
	00CF			
0054	4300	B	X'80'	
	0080			
* *				
0058	01A0	START	LM	TTY,DATA
	0080			SET UP REGISTERS
005C	9EAB	OCR	TTY,TWRT	WRITE MODE
005E	018E	BALR	RET,OUT	XOFF
0060	94DD	EXBR	DAT,DAT	
0062	018E	BALR	RET,OUT	*
0064	9EAC	OCR	TTY,TREAD	READ MODE
0066	9DA9	SSR	TTY,STAT	
0068	2241	BFBS	4,1	WAIT FOR BREAK
006A	9EAB	OCR	TTY,TWRT	WRITE MODE
006C	08DF	LHR	DAT,XON	
006F	018E	BALR	RET,OUT	XON
0070	9DA9	SSR	TTY,STAT	WAIT FOR
0072	2091	BTBS	9,1	XON CHARACTER
0074	4300	B	LOAD	DO AUTO LOAD
	0050			
* *				
0078	0294	DC	X'0294'	BINDV
007A	0298	DC	X'0298'	ROUTDV
007C	0294	DC	X'0294'	SINDV
007E	0298	DC	X'0298'	LISTDV
* *				
0080	0002	DATA	DC	2
0082	0098	DC	X'98'	

0084	0094		DC	X'94'
0086	2A93		DC	X'2A93'
0088	008C		DC	OUTPUT
008A	0091		DC	X'91'
008C	9DA9	OUTPUT	SSR	TTY,STAT
008E	20F1		BTBS	15.1
0090	9AAD		WDR	TTY,DAT
0092	0308		BR	RET
0093		END	EQU	*-1
0094			END	

NO ERRORS

DAT	000D
DATA	0080
END	0093
LOAD	0050
OUT	000F
OUTPUT	008C
RET	0008
START	0058
STAT	0009
TREAD	000C
TTY	000A
TWRT	000B
XON	000F

TEST AID



M49-410 TEST AID INFORMATION SPECIFICATION

1. INTRODUCTION

This Information Specification covers installation, operation, and maintenance of the M49-410 Test Aid (02-276) and the associated logic in the Processor. Refer to 02-276D08 for schematics of the M49-410 Test Aid.

2. GENERAL DESCRIPTION

The Test Aid, consists of a switch/display panel and a 17-229 logic card which attaches to the 35-446 CPU-HI board. The Test Aid provides the ability to examine the addresses of the micro-code and to stop Processor clocks at option.

3. INSTALLATION

This section provides the information necessary to install the Test Aid on the Processor.

The installation procedure is:

1. Remove the display from the chassis.
2. Place Test Aid logic card over pins on CPU-HI board (installed in Slot 6 of CPU chassis) (refer to Figure 1) and press down until Test Aid logic card rests on spacers on CPU-HI board. The switch/display panel assembly may be placed on a table or mounted on the chassis as shown in Figure 2.

CAUTION

Refer to Section 12 for use of extender boards.

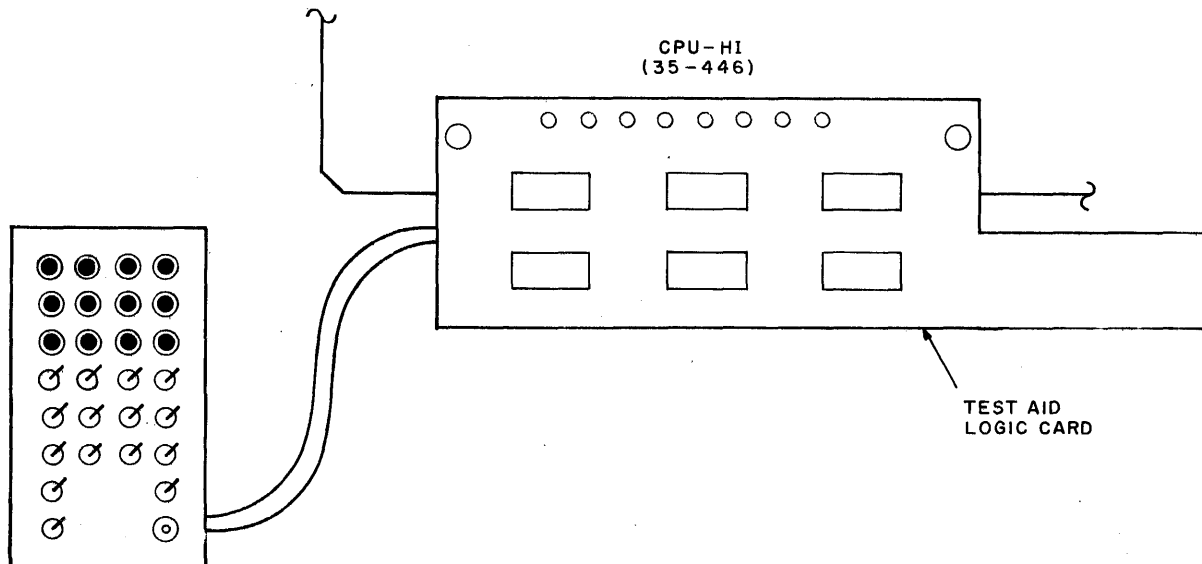

Figure 1. Test Aid Installation

This information is proprietary and is supplied by INTERDATA for the sole purpose of using and maintaining INTERDATA supplied equipment and shall not be used for any other purpose unless specifically authorized in writing.

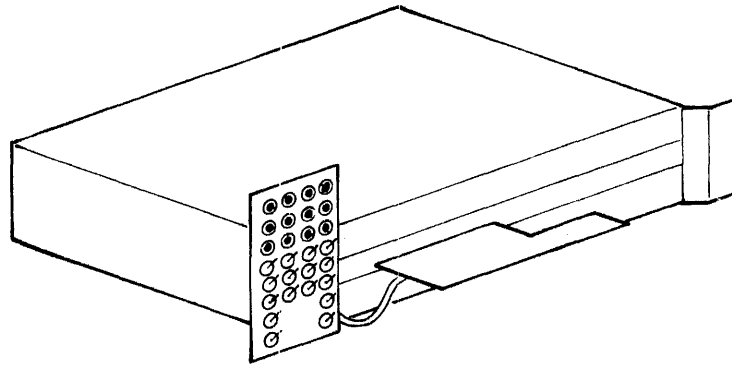

Figure 2. Switch Panel Mounting

4. POWER

Power and ground are supplied by the CPU-III board. There are no other power requirements.

5. OPERATION

Refer to Figure 3 during the operating description. The 12 light-emitting diodes (LEDs) numbered 4-15 display the contents of the ROM Address Register. The numbers assigned to the LEDs correspond to the ROM Address Register bits. The 12 toggle switches labelled 4-15 provide the ability to set-up a match address. The Test Aid logic stops the Processor clocks when the selected "match address" is in the ROM Address Register and the Address Match switch is in the ON (up) position.

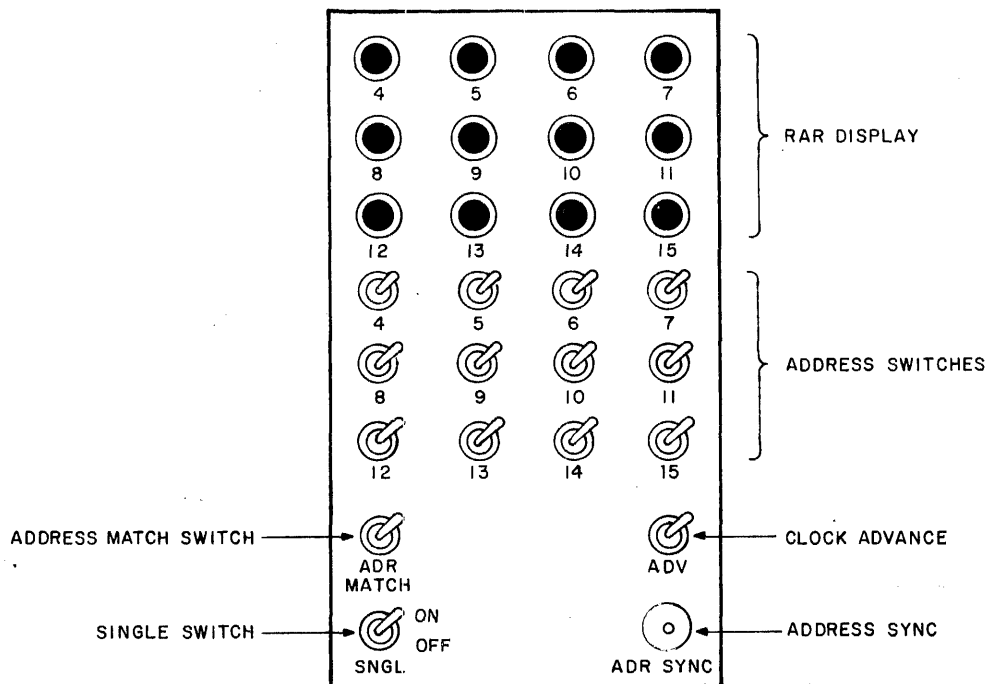

Figure 3. Switch Panel

6. ADDRESS MATCH SWITCH

After selecting an address on the Address Switches, place the Address Match in the ON (up) position. When the ROM Address Register of the Processor contains the "match address", the Processor clocks are stopped on the next clock. The Address Match Switch feature can also be used to interrupt and continue micro-code loops. Follow the procedure for address matching. Select an address within a micro-code loop. Once the match has been found, depressing the Clock Advance (ADV) switch once allows the micro-code to go through the loop and match on the selected address again.

This information is proprietary and is supplied by INTERDATA for the sole purpose of using and maintaining INTERDATA supplied equipment and shall not be used for any other purpose unless specifically authorized in writing.

NOTE

The LED display in most cases is one increment ahead of the match address. The micro-code instruction at the address selected has been executed or is one clock into execution when the match occurs and the Processor clocks stop.

7. CLOCK ADVANCE SWITCH

The Clock Advance switch allows the Processor to generate one clock each time it is depressed when the Address Match or Single switches are in the ON (up) position.

8. SINGLE SWITCH

When the Single switch is in the ON (up) position, the Processor clocks are stopped. With this switch ON the micro-program may be executed in a micro-instruction at a time by depressing the Clock ADVance switch.

9. ADDRESS SYNC

Address Sync is a BNC connector whose output is a low going signal that becomes active when the Address switches and the contents of the ROM Address Register compare. The contents of the ROM specified by the ROM Address Register will not be loaded into the ROM Data Register until the next clock RD (CKRD0).

10. OPTION

Pins 'A' and 'B' are normally wired together. Pin 'A' is the output of a comparator that compares the ROM Address Register and the Address switches. When they compare, the signal on Pin A goes high (+5 VDC) causing Processor clocks to stop. Removing the wire between Pins 'A' and 'B' provides a means to bring in any high active signal on Pin 'B' to stop Processor clocks. Removing the wire between 'A' and 'B' will remove the capability to stop Processor clocks on address match. See Figure 4.

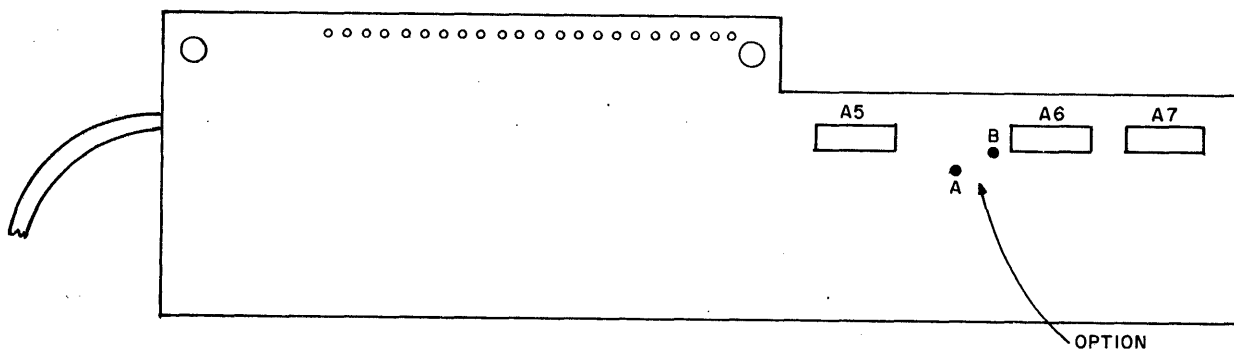

Figure 4. Option Connections

11. TEST AID MAINTENANCE

11.1. Timing

This section defines timing sequences (Figure 5) in the logic of the Test Aid and associated logic in the Processor. Refer to (01-058D08) the Processor schematics, Sheet 13, Clock Control, for logic detail of the clock stop.

TIMING CHART FOR ADDRESS MATCH

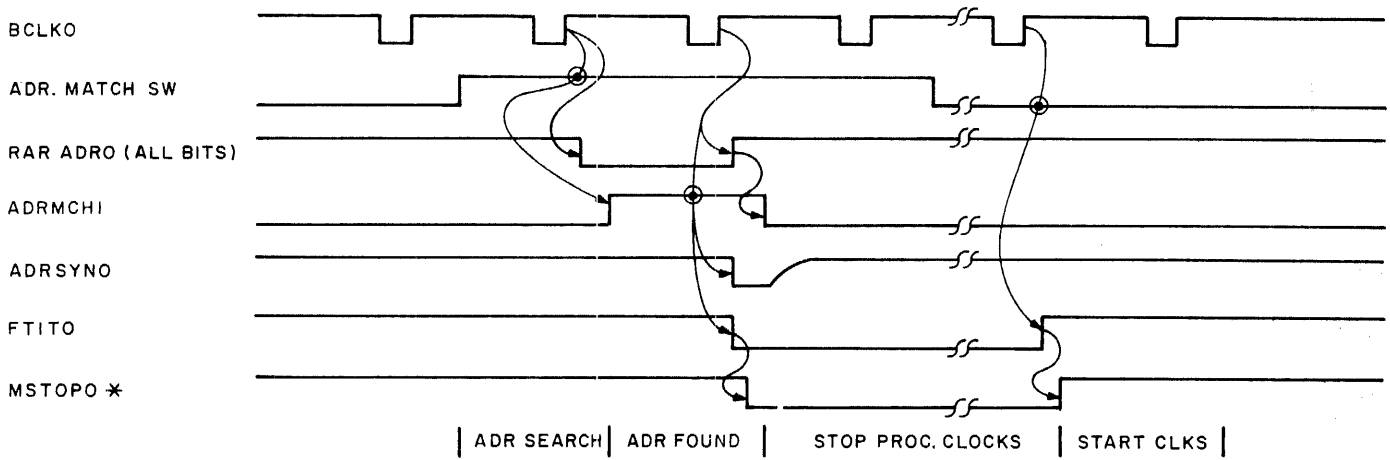

TIMING CHART FOR SINGLE STEPPING

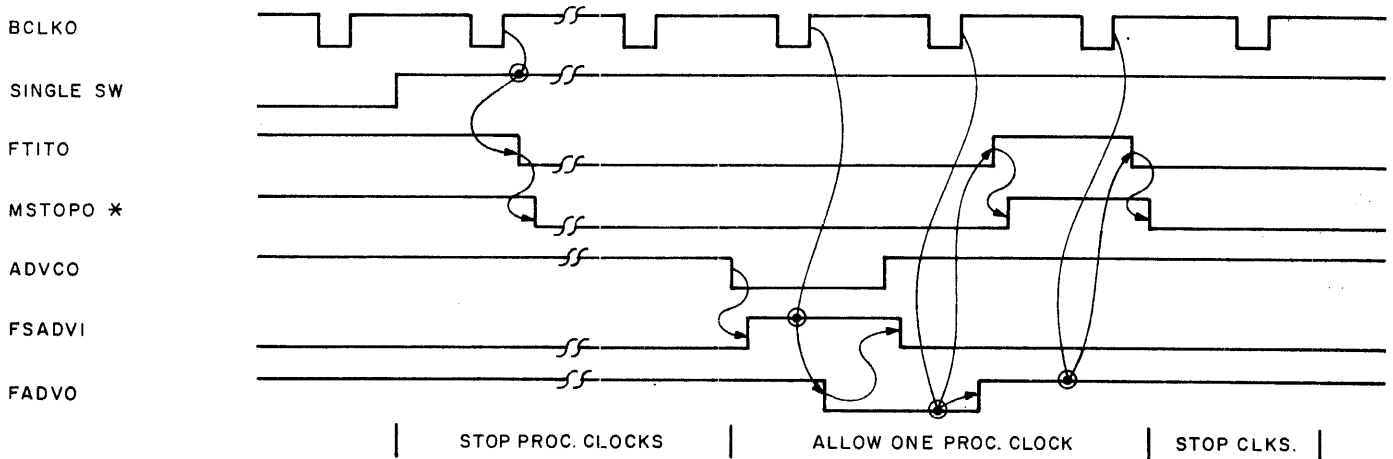

* MSTOPO IS A CLOCK STOPPING SIGNAL INTERNAL TO THE MODEL PROCESSOR.
WHEN ACTIVE ALL PROCESSOR CLOCKS EXCEPT CLKI, BCLKI AND BCLKO ARE STOPPED.

Figure 5. Test Aid Timing

11.2 Mnemonic Definitions

- ADRMCHI - This signal is active when the contents of the ROM Address Register and the Address switches are equal.
- ADVCO - Flip-flop output which goes active when the ADV switch is depressed, inactive when the ADV switch is released.
- BCLK0 - Derived from the Processor. This is a clock that cannot be stopped by any clock stop in the Processor. BCLK0 width is typically 60 nanoseconds and the period is typically 250 nanoseconds.
- FADVO - When active, allows FTITO to be inactive for one clock period. If ADVCO and BCLK0 are active at the same time, the FADVO flip-flop sets.
- FTITO - This flip-flop is reset by Single switch ON, Address Match switch ON, and a match address.
- MCH06-150 - When active indicates that a particular address switch has been selected.
- RAR06-150 - ROM Address Register outputs indicating the address of the micro-instruction to be executed on the next clock.

This information is proprietary and is supplied by INTERDATA for the sole purpose of using and maintaining INTERDATA supplied equipment and shall not be used for any other purpose unless specifically authorized in writing.

12. USE OF MODEL 70 EXTENDER BOARD (11-103) ON THE PROCESSOR

12.1 Hazards

All Model 70 extender boards, below revision level 11-103R02, when used to extend Processor boards, present two hazards.

1. All stiffening metal on the extender board when being plugged in becomes +5VDC. This hazard exists with either Processor board on the extender.
2. When the Test Aid is installed and the CPU-LO is on the extender board, a stiffening bar located on the underside of the extender board rests on top of the Test Aid logic card and forces it down possibly causing a short.

12.2 Modification

The following information describes how to modify the 11-103R01 extender board:

1. Pins 200-0, 200-1, 241-0 and 241-1 are tied into the ground bus of the extender board. These pins in the Processor are +5VDC. Both ends of the extender board tie these pins to the extender board ground but via feedthrough holes causing the ground bus to become +5VDC. Cut the copper between these feedthrough holes and the extender board ground bus. Add a strap from the copper run of Pins 101-0, 101-1, 140-0 and 140-1 to the adjacent ground shield to restore the continuity of back panel ground to extender board ground.
2. Remove stiffening bar on underside of extender board. Three new clearance holes must be drilled so that the stiffening bar mounts horizontally rather than vertically. The original screws may bottom out; if so, use #4-40 x 5/8 screws. Refer to Figure 6.

After this change is made, care should still be taken to insure that the Test Aid logic card is not shorting to the stiffening bar.

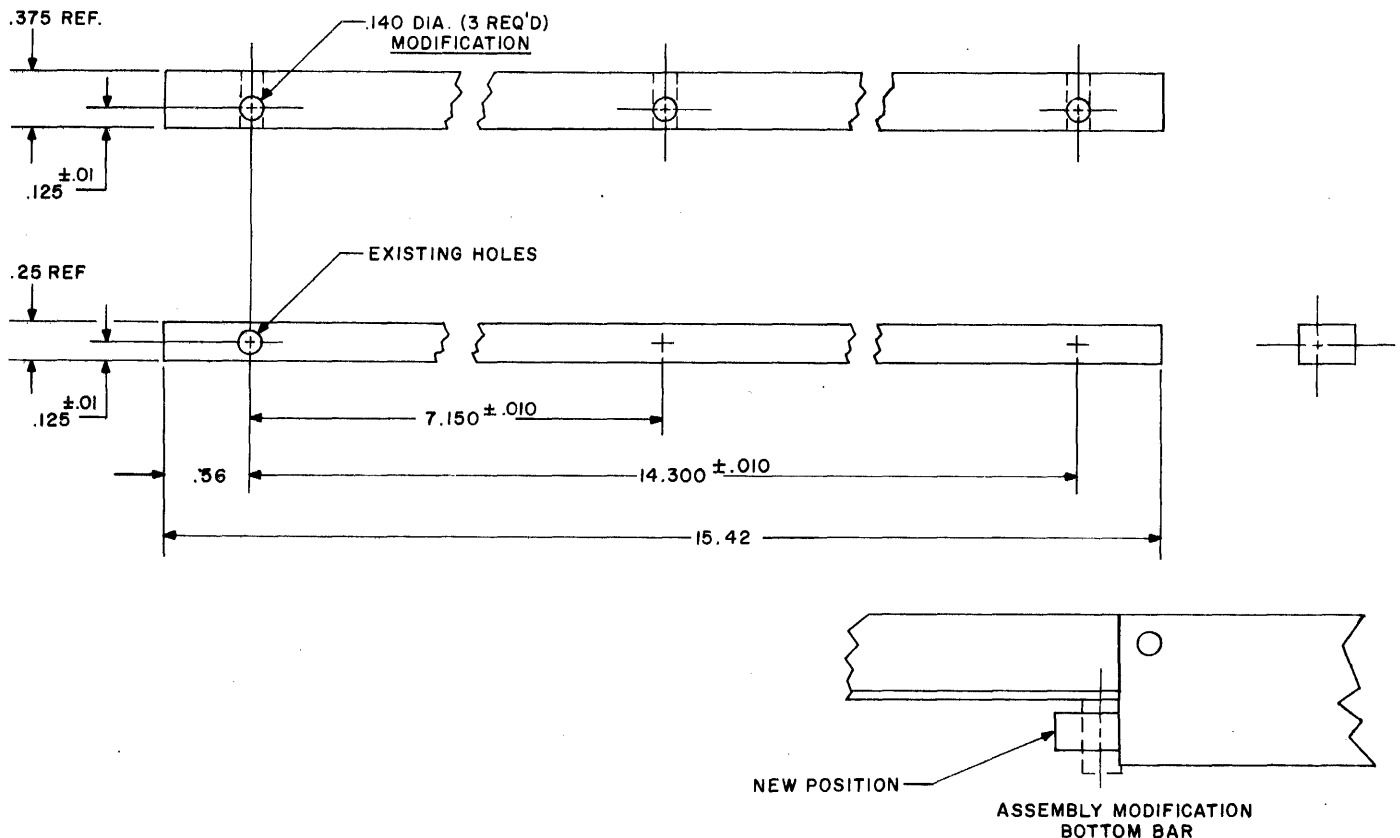

Figure 6. Stiffening Bar

This information is proprietary and is supplied by INTERDATA for the sole purpose of using and maintaining INTERDATA supplied equipment and shall not be used for any other purpose unless specifically authorized in writing.

MICRO-PROGRAMS



```

*
* MODEL 7/16 WITHOUT HIGH SPEED ALU
*
* COPYRIGHT INTERDATA INC. MARCH 1974
* MARCH 7, 1974
*
* IFA GABBERT
*
0022 P. TR EQU *22*
0024 APSW EQU *24*
0026 ALOC EQU *26*
0030 ILPSW EQU *30*
0038 OMPSW EQU *38*
0040 OIPSW EQU *40*
0048 OEPSW EQU *48*
0000 SPTABL EQU *00*
*
*
* BEGIN INSTRUCTION DECODING
* INSTRUCTION READ IS IN PROGRESS
*
000 3E8FC START B ATN+CATN+SNGL+MALF,HELP TEST FOR INTERRUPTS
*
* IF NO INTERRUPTS, CONTINUE INSTRUCTION FETCH
*
001 0E228 C LOC,LOC,INC INCREMENT LOC
002 90DCC L AR,YS,MR+L1 VECTOR THRU DROM1
*
* IF RR OR SF, DROM SUPPRESS MR
* AR CONTAINS SECOND OPERAND
* IF RX OR RS, AR CONTAINS INDEX VALUE
*
*
* COMMON RS
*
003 0E228 RS C LOC,LOC,INC INCREMENT LOC
004 38406 B AMOD,R SX
005 20C8C L AR,MDR,D2
* 2ND OPERAND TO AR, VECTOR THRU DROM2
*
006 0A882 RSX A MDR,MDR,NF+NC FORM A+(X2)
007 20C8C L AR,MDR,D2
* 2ND OPERAND TO AR, VECTOR THRU DROM2
*
* ILLEGAL INSTRUCTIONS TRAPPED IN DROM3
*
008 02C02 ILEG LI AR,2
009 0C22C S LOC,LOC DECREMENT LOC
00A 02A30 LI MAR,ILPSW
00B 301C1 B GENSWP DC PSW SWAP
*
*
* COMMON RX
*
00C 38410 RX B AMOD,RXX
00D 80A8C L MAR,MDR,MR FETCH (A)

```

7160001
7160002
7160003
7160004
7160005
7160006
7160007
7160008
7160009
7160010
7160011
7160012
7160013
7160014
7160015
7160016
7160017
7160018
7160019
7160020
7160021
7160022
7160023
7160024
7160025
7160026
7160027
7160028
7160029
7160030
7160031
7160032
7160033
7160034
7160035
7160036
7160037
7160038
7160039
7160040
7160041
7160042
7160043
7160044
7160045
7160046
7160047
7160048
7160049
7160050
7160051
7160052
7160053
7160054
7160055

00E	0E228	C	LOC,LOC,INC	INCREMENT LOC	71600560
00F	20C8C	L	AR,MDR,D2		71600570
			* 2ND OPERAND TO AR, VECTOR THRU DROM2		71600580
			*		71600590
010	8AA82	RXX	A	MAR,MDR,MR+NF+NC	71600600
011	0E228	C	LOC,LOC,INC	INCREMENT LOC	71600610
012	20C8C	L	AR,MDR,D2		71600620
			* 2ND OPERAND TO AR, VECTOR THRU DROM2		71600630
			*		71600640
			*		71600650
			* STORE HALFWORD (ENTERED FROM DROM1)		71600660
			*		71600670
013	38415	STH	B	AMOD,STHX	71600680
014	20A8C	L	MAR,MDR,D2	ADDRESS A	71600690
			* GO THRU DROM2 TO STH1		71600700
			*		71600710
015	0AA8C	STHX	A	MAR,MDR	71600720
016	4090C	STH1	L	MDR,YD,MW	71600730
017	0E228	C	LOC,LOC,INC	STORE	71600740
018	C0E0C	NOCCC	L	FLR,PSW,IR	71600750
				ADRS NEXT	71600760
				NO CC CHANGE	71600770
			*		71600780
			* SHORT IMMEDIATES		71600790
			*		71600800
019	02C0F	SHORT	LI	AR,'F'	71600810
01A	24C82	N	AR,MDR,NF+NC+D2	VECTOR THRU DROM2	71600820
			*		71600830
			* NH,NHI,NHR		71600840
			*		71600850
01B	C510C	NH	N	YD,YD,IR	71600860
			*		71600870
			*		71600880
			* OH,OHI,OHR		71600890
			*		71600900
01C	C710C	OH	O	YD,YD,IR	71600910
			*		71600920
			*		71600930
			* XH,XHI,XHR		71600940
			*		71600950
01D	C910C	XH	X	YD,YD,IR	71600960
			*		71600970
			*		71600980
			* LH,LHI,LHR,LIS		71600990
			*		71601000
01E	C70CC	LH	O	YD,NULL,IR	71601010
			*		71601020
			*		71601030
01F	CD0C0	LCS	S	YD,NULL,NC+IR	71601040
			*		71601050
			*		71601060
			* CH,CHI,CHR		71601070
			*		71601080
020	0890C	CH	X	MDR,YD	71601090
021	30824	B	L,DIFFER	COMPARE SIGNS	71601100
			* SIGNS ALIKE, SUBTRACT TO SET FLAGS		71601110
022	02E00	LI	FLR,0		71601120

		*				71601130
		* CLH,CLHI,CLHR				71601140
		*				71601150
023	CCD0C	CLH	S	AR,YD,IR		71601160
		*				71601170
024	00D06	DIFFER	L	AR,YD,SL+CO	SET C=1ST OP SIGN	71601180
025	C6D01		O	AR,YD,NA+NC+IR	SET G,L & FETCH NEXT	71601190
		*				71601200
		* ACH,ACHR				71601210
		*				71601220
026	00E0C	ACH	L	FLR,PSW	PROPOGATE FLAGS	71601230
		*				71601240
		* AH,AHI,AHR,AIS				71601250
		*				71601260
027	CB10C	AH	A	YD,YD,IR		71601270
		*				71601280
		*				71601290
		* SCH,SCHR				71601300
		*				71601310
028	00E0C	SCH	L	FLR,PSW	PROPOGATE FLAGS	71601320
		*				71601330
		* SH,SHI,SHR,SIS				71601340
		*				71601350
029	CD10C	SH	S	YD,YD,IR		71601360
		*				71601370
		*				71601380
		*				71601390
		* BXLE,BXH				71601400
		*				71601410
02A	3842C	BXLH	B	AMOD,BXLHX		71601420
02B	02C00		LI	AR,0		71601430
02C	0A882	BXLHX	A	MDR,MDR,NF+NC	FORM A+(X2)	71601440
02D	00D2C		L	AR,YDP1		71601450
02E	0E228		C	LOC,LOC,INC	INCREMENT LOC	71601460
02F	0A542		A	MRO,YDM1,NF+NC	(R1)+(R1+1)	71601470
030	0124C		L	YDP1,MRO	INDEX	71601480
031	00D2C		L	AR,YDP1	NOP	71601490
032	20C4C		L	AR,MRO,D2		71601500
		* INCREMENTED INDEX TO AR,VECTOR THRU DROM2				71601510
		*				71601520
033	0CD04	BXH	S	AR,YD,CO	COMPARE	71601530
034	34038		B	C,BRANCH	BRANCH IF INDEX GREATER	71601540
035	C0E0C	NOBRAN	L	FLR,PSW,IR		71601550
		*				71601560
		*				71601570
036	0CD04	BXLE	S	AR,YD,CO	COMPARE	71601580
037	34035		B	C,NOBRAN	BRANCH IF INDEX NOT GREATER	71601590
038	0028C	BRANCH	L	LOC,MDR	DO BRANCH	71601600
039	C0E0C		L	FLR,PSW,IR		71601610
03A	00000		DC	0	FILLER	71601620
		*				71601630
		*				71601640
		*				71601650
		* BAL,BALR (AR=BRANCH ADRS)				71601660
		*				71601670
03B	0102C	BAL	L	YD,LOC	DO LINK	71601680
03C	062CC		O	LOC,NULL	DO BRANCH	71601690

03D	00E0C		L	FLR,PSW,IR		71601780
		*				71601780
		*				71601720
		* BTC,BTCR				71601730
		*				71601740
03E	30442	BTC	B	MSK,DOB		71601750
03F	00A2C	NOB	L	MAR,LOC		71601760
040	00E0C		L	FLR,PSW,IR		71601770
		* INSTRUCTION FETCH CONTINUES AT '000'				71601780
		*				71601790
		*				71601800
		* BFC,BFCR				71601810
		*				71601820
041	3043F	BFC	B	MSK,NOB		71601830
042	062CC	DOB	O	LOC,MULL		71601840
043	00E0C		L	FLR,PSW,IR		71601850
		*				71601860
		* INPUT/OUTPUT INSTRUCTION SETUPS				71601870
		*				71601880
044	01190	AIR	L	YD,IO,ACK	ACKNOWLEDGE	71601890
045	02E00		LI	FLR,0	NOF	71601900
		*				71601910
		* COMMON RDR,WDR,RHR,WHR,OCR,SSR,AIR				71601920
		*				71601930
046	01900	RRIC	L	IO,YD		71601940
047	01910		L	IO,YD,ADRS	ADDRESS THE DEVICE	71601950
048	209CF		L	MDR,YS,CS+D2	VECTOR THRU DROM2	71601960
		*				71601970
		*				71601980
049	01190	AI	L	YD,IO,ACK	ACKNOWLEDGE	71601990
04A	02E00		LI	FLR,0	NOF	71602000
		*				71602010
		* COMMON RD,WD,RH,WH,OC,SS,AI				71602020
		*				71602030
04B	01900	RXIO	L	IO,YD		71602040
04C	01910		L	IO,YD,ADRS	ADDRESS THE DEVICE	71602050
		*				71602060
		* COMMON STB,LB,CLB,AHM,RD,WD,RH,WH,OC,SS,AI				71602070
		*				71602080
04D	0E228	STR	C	LOC,LOC,INC	INCREMENT LOC	71602090
04E	38450		R	AMOD,STBX		71602100
04F	A0A8C		L	MAR,MDR,MR+D2	VECTOR THRU DROM2	71602110
		*				71602120
050	AAA82	STBX	A	MAR,MDR,NF+NC+NR+D2	VECTOR THRU DROM2	71602130
		*				71602140
		*				71602150
		* BYTE HANDLING INSTRUCTIONS				71602160
		*				71602170
051	02CFF	STBR	LI	AR,'FF'		71602180
052	04DCC		N	AR,YS		71602190
053	089CC		X	MDR,YS	CLEAR LO 2ND OP	71602200
054	02CFF		LI	AR,'FF'		71602210
055	04D0C		N	AR,YD	CLEAR HI 1ST OP	71602220
056	2768C		O	YS,MDR,D2	TO NOCCC	71602230
		*				71602240
		*				71602250
057	4090F	STB1	L	MDR,YD,CS+MW	INSRT BYTE & STORE	71602260

053	00A2C		L	MAR,LOC	ADRS NEXT INSTR	71602270
059	C0E0C		L	FLR,PSW,IR		71602280
		*				71602290
		*				71602300
05A	02CFF	LBR	LI	AR,'FF'		71602310
05B	251CC		N	YD,YS,D2	TO NOCCC	71602320
		*				71602330
		*				71602340
05C	00C8F	LB	L	AR,MDR,CS		71602350
05D	024FF		LI	MRO,'FF'		71602360
05E	0504C		N	YD,MRO	LOAD LU	71602370
05F	00A2C		L	MAR,LOC	ADRS NEXT INSTR	71602380
060	C0E0C		L	FLR,PSW,IR		71602390
		*				71602400
		*				71602410
061	02CFF	CLB	LI	AR,'FF'		71602420
062	0450E		N	MRO,YD,NF	1ST OP BYTE	71602430
063	00C8F		L	AR,MDR,CS		71602440
064	026FF		LI	MR1,'FF'		71602450
065	04C6E		N	AR,MR1,NF	2ND OP BYTE	71602460
066	0CC4C		S	AR,MRO	DO COMPARE	71602470
067	C0A20		L	MAR,LOC,NC+IR		71602480
		*				71602490
		*				71602500
068	211CF	EXRK	L	YD,YS,CS+D2	TO NOCCC	71602510
		*				71602520
		*				71602530
		*		INPUT/OUTPUT INSTRUCTIONS		71602540
		*				71602550
		*				71602560
069	01883	WD	L	IO,MDR,CS		71602570
06A	01887		L	IO,MDR,CS+DA	DATA AVAILABLE	71602580
06B	C0A2C		L	MAR,LOC,IR		71602590
		*				71602600
		*				71602610
06C	01784	RDR	L	YS,IO,DR	DATA REQUEST	71602620
06D	C0A2C		L	MAR,LOC,IR		71602630
		*				71602640
		*				71602650
06E	00983	RD	L	MDR,IO,CS		71602660
06F	00987		L	MDR,IO,CS+DR	DATA REQUEST	71602670
070	4088C		L	MDR,MDR,MW	STORE IT	71602680
071	C0A2C		L	MAR,LOC,IR		71602690
		*				71602700
		*				71602710
072	01788	SSR	L	YS,IO,STAT	STATUS REQUEST	71602720
073	00A2C		L	MAR,LOC	NOP	71602730
074	C0FCC		L	FLR,YS,IR	LS 4 BITS TO CC	71602740
		*				71602750
		*				71602760
075	00983	SS	L	MDR,IO,CS		71602770
076	0098B		L	MDR,IO,CS+STAT	STATUS REQUEST	71602780
077	40E8F		L	FLR,MDR,CS+MW	LS 4 BITS TO CC, STORE	71602790
078	C0A20		L	MAR,LOC,NC+IR		71602800
		*				71602810
		*				71602820
		*				71602830

079	01883	OC	L	IO,MDR,CS		71602840
07A	0188B		L	IO,MDR,CS+CMD	OUTPUT COMMAND	71602850
07P	C0A2C		L	MAR,LOC,IR		71602860
		*				71602870
		*				71602880
		* AUTOLOAD				71602890
		*				71602900
07C	0068C	AL	L	MRI,MDR	FINAL ADRS	71602910
07D	82A78		LI	MAR,'78',MR		71602920
07E	02C80		LI	AR,'80'	START ADRS	71602930
07F	0C66C		S	MRI,MR1	START MINUS END	71602940
080	342E0		B	C,FINIS	START GREATER THAN END	71602950
081	01883		L	IO,MDR,CS		71602960
082	01993		L	IO,MDR,CS+ADRS	ADDRESS THE DEVICE	71602970
083	01880		L	IO,MDR		71602980
084	01888		L	IO,MDR,CMD	OUTPUT COMMAND	71602990
085	82A80		LI	MAR,'80',MR		71603000
		*				71603010
		*				71603020
086	00F88	INAL	L	FLR,IO,STAT		71603030
087	33AE1		B	VGL,END	BAD STATUS	71603040
088	34086		B	C,INAL	JUST BUSY	71603050
089	00584		L	MRO,IO,DR	INPUT DATA	71603060
08A	0084F		L	MDR,MRO,CS		71603070
08B	02CFF		LI	AR,'FF'		71603080
08C	0444C		N	MRO,MRO	TEST	71603090
08D	02C01		LI	AR,1		71603100
08E	31A4A		B	GL,LOOPR1	NON ZERO	71603110
08F	30086		B	INAL	SKIP LEADER	71603120
		*				71603130
		*				71603140
		*				71603150
		* STORE MULTIPLE, LOAD MULTIPLE, SUPERVISOR CALL				71603160
		*				71603170
090	00481	STMLM	L	MRO,MDR,SR+NC	SAVE INSTR	71603180
091	02C78		LI	AR,'78'		71603190
092	0444C		N	MRO,MRO	ISOLATE YD FIELD	71603200
093	00441		L	MRO,MRO,SR+NC		71603210
094	00441		L	MRO,MRO,SR+NC	MRO=2X YD FIELD	71603220
095	80DCC		L	AR,YS,MR	(X2) TO AR	71603230
096	0E228		C	LOC,LOC,INC		71603240
097	38499		B	AMOD,STMLMX		71603250
098	02C00		LI	AR,0		71603260
099	8AA8C	STMLMX	A	MAR,MDR,MR	FETCH A+(X2)	71603270
09A	02C1E		LI	AR,'1E'		71603280
09B	0844C		X	MRO,MRO	COMPLEMENT COUNT	71603290
09C	22C02		LI	AR,2,D2		71603300
		*				71603310
		*				71603320
09D	4092C	STM	L	MDR,YDP1,MW	STORE REGISTER	71603330
09E	0C444		S	MRO,MRO,CO	DECREMENT COUNT	71603340
09F	3403F		B	C,NOB	DONE	71603350
0A0	2AAA0		A	MAR,MAR,NC+D2	LOOP THRU DROM2	71603360
		*				71603370
		*				71603380
0A1	0128C	LM	L	YDP1,MDR	LOAD REGISTER	71603390
0A2	0C444		S	MRO,MRO,CO	DECREMENT COUNT	71603400

0A3	3403F		B	C,NOB	DONE	71603110
0A4	AAAA0		A	MAR,MAR,NC+MR+D2	LOOP THRU DROM2	71603120
		*				71603130
		*				71603140
		* SHORT BRANCHES				71603150
		*				71603160
0A5	3043F	BFFR	B	MSK,NOB		71603170
0A6	02C02	DOFRB	LI	AR,2		71603180
0A7	0C22C		S	LOC,LOC	POINT TO HERE	71603190
0A8	02CDF		LI	AR,'F'		71603200
0A9	24C8C		N	AR,MDR,D2	DISPLACEMENT (D)	71603210
		*				71603220
		*				71603230
0AA	0CCCC	BKWD	S	AR,NULL,NC	AR=-D	71603240
		*				71603250
0AB	0A220	FRWD	A	LOC,LOC,NC	LOC+2*(AR)	71603260
0AC	0A220		A	LOC,LOC,NC		71603270
0AD	C0E0C		L	FLR,PSW,IR		71603280
		*				71603290
		*				71603300
0AE	304A6	BTFR	B	MSK,DOFRB		71603310
0AF	00A2C		L	MAR,LOC		71603320
0B0	C0E0C		L	FLR,PSW,IR		71603330
		*				71603340
		*				71603350
		*				71603360
		* SHIFT INSTRUCTIONS				71603370
		*				71603380
		* COMMON SRLS,SRHL,SRHA				71603390
		*				71603400
0B1	0E228	SRH	C	LOC,LOC,INC		71603410
0B2	384B4		B	AMOD,SRHX		71603420
0B3	02C00		LI	AR,0		71603430
0B4	0A882	SRHX	A	MDR,MDR,NF+NC	FORM A+(X2)	71603440
		*				71603450
0B5	02C0F	SRLS	LI	AR,'F'		71603460
0B6	0488E		N	MDR,MDR,NF	COUNT	71603470
0B7	01106		L	YD,YD,SL+CO	PRE-SHIFT	71603480
0B8	004CD		L	MR0,NULL,SR	SAVE SIGN	71603490
0B9	22C01		LI	AR,1,D2		71603500
		*				71603510
		*				71603520
0BA	0C886	SRHL	S	MDR,MDR,NF+CO	DECREMENT COUNT	71603530
0BB	340C2		B	C,SRHLX	DONE	71603540
0BC	00446		L	MR0,MR0,SL+CO	SIGN TO CARRY	71603550
0BD	2110D		L	YD,YD,SR+D2	LOOP THRU DROM2	71603560
		*				71603570
		*				71603580
0BE	0C886	SRHA	S	MDR,MDR,NF+CO	DECREMENT COUNT	71603590
0BF	340C2		B	C,SRHLX	DONE	71603600
0C0	00646		L	MR1,MR0,SL+CO	PROPOGATE SIGN	71603610
0C1	2110D		L	YD,YD,SR+D2	LOOP THRU DROM2	71603620
		*				71603630
0C2	00446	SRHLX	L	MR0,MR0,SL+CO	CATCH LAST BIT	71603640
0C3	0110D		L	YD,YD,SR	COMPENSATE PRE-SHIFT	71603650
0C4	00A20		L	MAR,LOC,NC		71603660
0C5	C7101		O	YD,YD,NA+NC+IR		71603670

		*				71603980
		* COMMON	SLLS,SLHL,SLHA			71603990
		*				71604000
006	01106	SLHA	L	YD,YD,SL+CO		71604010
007	0060D		L	MR1,NULL,SR	SAVE SIGN	71604020
		*				71604030
008	0E228	SLH	C	LOC,LOC,INC		71604040
009	384CE		B	AMOD,SLHX		71604050
00A	02C00		LI	AR,0		71604060
00B	0A882	SLHX	A	MDR,MDR,NF+NC	FORM A+(X2)	71604070
		*				71604080
00C	02C0F	SLLS	LI	AR,*F*		71604090
00E	0488E		N	MDR,MDR,IF	COUNT	71604100
00E	01105		L	YD,YD,SR+CO	PRE-SHIFT	71604110
00F	004CE		L	MR0,NULL,SL	SAVE LSB	71604120
000	22C01		LI	AR,1,D2		71604130
		*				71604140
		*				71604150
001	0C886	SLHLL	S	MDR,MDR,NF+CO	DECREMENT COUNT	71604160
002	340D5		B	C,SLHLX	LOOP	71604170
003	00445		L	MR0,MR0,SR+CO		71604180
004	2110E		L	YD,YD,SL+D2	LOOP THRU DROM2	71604190
		*				71604200
005	00445	SLHLX	L	MR0,MR0,SR+CO		71604210
006	0110E		L	YD,YD,SL	COMPENSATE PRE-SHIFT	71604220
007	00A20		L	MAR,LOC,NC		71604230
008	C7101		O	YD,YD,NA+NC+IR		71604240
		*				71604250
		*				71604260
009	0C886	SLHAL	S	MDR,MDR,NF+CO	DECREMENT COUNT	71604270
00A	340DC		B	C,SLHAX		71604280
00B	2110E		L	YD,YD,SL+D2	LOOP THRU DROM2	71604290
		*				71604300
00C	00C6C	SLHAX	L	AR,MR1	SIGN TO AR	71604310
00D	00706		L	MR1,YD,SL+CO	SET C	71604320
00E	00661		L	MR1,MR1,SR+NC		71604330
00F	C7060		O	YD,MR1,NC+IR		71604340
		*				71604350
		*				71604360
		* COMMON	SRL,SRA			71604370
		*				71604380
0E0	384E2	SR	B	AMOD,SRX		71604390
0E1	02C00		LI	AR,0		71604400
0E2	0A882	SRX	A	MDR,MDR,NF+NC		71604410
0E3	0072C		L	MR1,YDP1		71604420
0E4	02C1F		LI	AR,*1F*		71604430
0E5	0110E		L	YD,YD,SL	PRE-SHIFT	71604440
0E6	0066E		L	MR1,MR1,SL		71604450
0E7	004CD		L	MR0,NULL,SR	SAVE SIGN	71604460
0E8	04882		N	MDR,MDR,NF+NC	MDR=COUNT	71604470
0E9	22C01		LI	AR,1,D2	VECTOR THRU DROM2	71604480
		*				71604490
		*				71604500
		*				71604510
0EA	384EC	SL	B	AMOD,SLX		71604520
0EB	02C00		LI	AR,0		71604530
0EC	0A882	SLX	A	MDR,MDR,NF+NC		71604540

0ED	0072D	L	MR1,YDP1,SR	PRL-SHIFT	71604.50
0EL	02C1F	LI	AR,'1F'		71604.60
0FF	0110D	L	YD,YD,SR		71604.70
0F0	004CE	L	MRO,NULL,SL	SAVE LSH	71604.80
0F1	04882	N	MDR,MDR,NF+NC		71604.90
0F2	22C01	LI	AR,1,D2		71604.00
		*			71604.10
		*			71604.20
		*	COMMON SLA,RRL,RLL		71604.30
		*			71604.40
0F3	384F5	RLR	B AMOD,RLRX		71604.50
0F4	02C00	LI	AR,0		71604.60
0F5	0A882	RLRX	A MDR,MDR,NF+NC		71604.70
0F6	0072C	L	MR1,YDP1		71604.80
0F7	00462	L	MRO,MR1,SL+NC		71604.90
0F8	00441	L	MRO,MRO,SR+NC	STRIP SIGN BIT	71604.00
0F9	02C1F	LI	AR,'1F'		71604.10
0FA	0488E	N	MDR,MDR,NF		71604.20
0FB	22C01	LI	AR,1,D2		71604.30
		*			71604.40
		*			71604.50
		*			71604.60
		*	COMMON INTERRUPT SUPPORT		71604.70
		*			71604.80
0FC	389BA	HELP	B MALF,TEST	PPF OR MPE	71604.90
0FD	3C18E	B	ATN,TEST0	ATN+PSW01	71604.00
0FE	3A164	B	CATN,CONSER		71604.10
0FF	30156	B	DISPLY		71604.20

						71604830
						71604840
						71604850
100	02600	PWRUP	LI	MR1,0	NO AUTO-RESTART	71604860
101	30103		R	PWRUPX		71604870
102	02601	ARST	LI	MR1,1	AUTO-RESTART	71604880
						71604890
103	02405	PWRUPY	LI	MRC,*05*	ADDRESS THE	71604900
104	31840		L	IO,MRO	LOADER STORAGE UNIT	71604910
105	01850		L	IO,MRO,ADRS	IF FALSE SYNC	71604920
106	32137		S	V,PWRUP2	NO AUTO-BOOT	71604930
						71604940
						71604950
						71604960
107	00F88	AUTO1	L	FLR,IO,STAT		71604970
108	34107		R	C,AUTO1		71604980
109	00087		L	AR,IO,DR+CS		71604990
10A	00F88	AUTO2	L	FLR,IO,STAT		71605000
10B	3410A		B	C,AUTO2		71605010
10C	00184		L	PSW,IO,DR		71605020
10D	00600		L	MR1, NULL, NC+JAM	SET CC	71605030
10E	06002		O	PSW,PSW, NF+NC	NEW PSW	71605040
10F	00F88	AUTO3	L	FLR,IO,STAT		71605050
110	3410F		B	C,AUTO3		71605060
111	00087		L	AR,IO,DR+CS		71605070
112	00F88	AUTO4	L	FLR,IO,STAT		71605080
113	34112		R	C,AUTO4		71605090
114	00384		L	LOC,IO,DR		71605100
115	0622C		O	LOC,LOC	NEW LOC	71605110
116	00F88	AUTO5	L	FLR,IO,STAT		71605120
117	34116		R	C,AUTO5		71605130
118	00087		L	AR,IO,DR+CS		71605140
119	00F88	AUTO6	L	FLR,IO,STAT		71605150
11A	34119		B	C,AUTO6		71605160
11B	00B84		L	MAR,IO,DR		71605170
11C	06AAC		O	MAR,MAR	START ADPS	71605180
11D	00F88	AUTO7	L	FLR,IO,STAT		71605190
11E	3411D		R	C,AUTO7		71605200
11F	00087		L	AR,IO,DR+CS		71605210
120	00F88	AUTO8	L	FLR,IO,STAT		71605220
121	34120		R	C,AUTO8		71605230
122	00784		L	MR1,IO,DR		71605240
123	0666C		O	MR1,MR1	FINAL ADPS	71605250
						71605260
124	00CAC		L	AR,MAR		71605270
125	0C66C		S	MR1,MR1	START MINUS END	71605280
126	3415F		R	C, IDLE		71605290
127	82C01		LI	AR,1,MR		71605300
						71605310
128	00F88	AUTO9	L	FLR,IO,STAT		71605320
129	3395F		R	VGL, IDLE	BAD STATUS	71605330
12A	34128		R	C,AUTO9	LOCK OR BUSY	71605340
12B	00983		L	MDR,IO,CS		71605350
12C	00987		L	MDR,IO,CS+DR	INPUT DATA	71605360
12D	4C66C		S	MR1,MR1,MW		71605370
12E	341CA		R	C,TEST2	DOPE	71605380
12F	8AAAC		A	MAR,MAR,MR		71605390

130	30128		B	AUTOL		71605400
		*				71605410
		*				71605420
		*				71605430
131	02A38	MMF	LI	MAR,OMPSW		71605440
132	00402		L	MRO,PSW,SL+NC	SHIFT PSW N11 2	71605450
133	00442		L	MRO,MRO,SL+NC		71605460
134	00446		L	MRO,MRO,SL+CO		71605470
135	341C1		B	C,GENSWP	MALE SWAP IF SET	71605480
136	3017D		B	CLRWIT	ELSE RUN	71605490
		*				71605500
		*		NORMAL POWER UP		71605510
		*				71605520
137	82A24	PWRUP2	LI	MAR,APSW,MR		71605530
138	0008C		L	PSW,MDR	LOAD PSW	71605540
139	82A26		LI	MAR,ALOC,MR		71605550
13A	00290		L	LOC,MDR,NC+JAM	LOAD LOC	71605560
13B	82A22		LI	MAR,PNTR,MR	FETCH RSAVE POINTER	71605570
13C	0E454		C	MRO,MRO,CYD+CMP	CLEAR YD FIELD	71605580
13D	0241E		LI	MRO,'1E'	COUNT	71605590
13E	02C02		LI	AR,'2'	INCREMENT	71605600
13F	80A8C		L	MAR,MDR,MR		71605610
		*				71605620
140	0128C	LMLP1	L	YDP1,MDR	LOAD REGISTER	71605630
141	0C444		S	MRO,MRO,CO	DECREMENT COUNT	71605640
142	34145		B	C,ENDLM1	DONE	71605650
143	8AAAC		A	MAR,MAR,MR	INCREMENT ADRS	71605660
144	30140		B	LMLP1	LOOP	71605670
		*				71605680
145	82A20	ENDLM1	LI	MAR,'20',MR	FETCH SAVED STATUS BYTE	71605690
146	00E8C		L	FLR,MDR	TEST IF LAST WAS RUN	71605700
147	3394B		B	VGL,PWRUP3	WAS NOT RUN MODE	71605710
		*				71605720
		*		DISPLAY WAS IN RUN MODE		71605730
		*				71605740
148	00E6C		L	FLR,MR1	TEST ARST FLAG	71605750
149	30931		B	L,MMF	DO MACHINE MALFUNCTION	71605760
14A	30152		B	LOCDIS	SHOW LOCATION COUNT	71605770
		*				71605780
		*		DISPLAY WAS NOT IN RUN MODE BEFORE POWER DOWN		71605790
		*				71605800
14B	02401	PWRUP3	LI	MRO,1		71605810
14C	01840		L	IO,MRO		71605820
14D	01850		L	IO,MRO,ADRS	ADDRESS THE DISPLAY	71605830
14E	00588		L	MRO,IO,STAT	SENSE STATUS	71605840
14F	00E4C		L	FLR,MRO		71605850
150	35152		B	CG,LOCDIS	NO BOOT LOAD	71605860
151	309AF		B	L,NODSPL	STATUS=XXXX 0X01	71605870
		*				71605880
152	02400	LOCDIS	LI	MRO,0	DISPLAY 1	71605890
153	0062C		L	MR1,LOC	DISPLAY 2	71605900
154	02845		LI	MDR,'45'	FN 5=LOC	71605910
155	30191		B	OUTDIS		71605920
		*				71605930
		*				71605940
		*				71605950
156	02401	DISPLY	LI	MRO,1		71605960

157	01840	L	IO,MR0		71605970
158	01850	L	IO,MR0,ADRS	ADDRESS THE DISPLAY	71605980
159	00588	L	MR0,IO,STAT	SENSE STATUS	71605990
15A	0064F	L	MR1,MR0,CS		71606000
15B	00E4C	L	FLR,MR0		71606010
15C	3419F	B	C,REGDIS	GENERAL REGISTER	71606020
15D	3295F	B	VL,IDLE		71606030
15E	3118C	B	G,PSWLOC	PSW OR LOC	71606040
		*			71606050
		*	UN-INTERRUPTABLE IDLE LOOP		71606060
		*			71606070
15F	0E226	IDLE	C LOC,LOC,SWA+CMP	SET WAIT LAMP	71606080
160	3A163	IDLE1	B CATN,IDLEX	EXECUTE	71606090
161	389D2	B	HALF,PWRDWN	POWER DOWN	71606100
162	30160	B	IDLE1	LOOP	71606110
		*			71606120
163	3917D	IDLEX	B SNGL,CLRWIT	SINGLE STEP	71606130
		*	FALL THRU TO CONSER		71606140
		*			71606150
		*			71606160
		*	CONSOLE SERVICE		71606170
		*			71606180
164	02401	CONSER	LI MR0,1		71606190
165	01840	L	IO,MR0		71606200
166	01850	L	IO,MR0,ADRS	ADRS THE CONSOLE	71606210
167	00588	L	MR0,IO,STAT	CONSOLE STATUS	71606220
168	00641	L	MR1,MR0,SR+NC	SHIFT STATUS BYTE	71606230
169	00661	L	MR1,MR1,SR+NC	RIGHT 4 PLACES	71606240
16A	00661	L	MR1,MR1,SR+NC		71606250
16B	00661	L	MR1,MR1,SR+NC		71606260
16C	301D5	B	PATCH		71606270
16D	02C0F	BACK	LI AR,OF	TEST STATUS 0:3	71606280
16E	08E62	X	FLR,MR1,NF+NC	FOR ANY BIT RESET	71606290
16F	37971	B	CVGL,MODE	IF SO, NO BOOT LOAD	71606300
170	3017D	B	CLRWIT	RUN IF BOOT LOAD	71606305
171	00E6C	MODE	L FLR,MR1	TEST STATUS 0:3	71606310
172	32177	B	V,FN	SGL, HALT, OR FN	71606320
173	80A2C	L	MAR,LOC,MR	READ MEMORY	71606330
174	30980	B	L,ADRMW	ADDRESS OR MEMORY WRITE	71606340
175	31184	B	G,DISMEM	MEMORY READ	71606350
176	3017D	B	CLRWIT	ASSUME RUN MODE	71606360
		*			71606370
		*	FUNCTION		71606380
		*			71606390
177	34156	FN	B C,DISPLY	STATUS = 11XX XXXX	71606400
178	00E4C	L	FLR,MR0	TEST STATUS 4:7	71606410
179	37956	B	CVGL,DISPLY	NOT FN 0	71606420
		*			71606430
		*	FUNCTION 0		71606440
		*			71606450
17A	02401	LI	MR0,1		71606460
17B	00E0F	L	FLR,PSW,CS	TEST PSW04	71606470
17C	342F4	B	C,IOSVC	DO CONSOLE INTERRUPT	71606480
		*			71606490
17D	00002	CLRWIT	L PSW,PSW,SL+NC	RESET WAIT BIT	71606500
17E	00001	L	PSW,PSW,SR+NC		71606510
17F	3003F	B	NOB	DO USER INSTRUCTION	71606520

		*				71606530
		*				71606540
		*				71606550
180	00980	ADRMW	L	MDR,IO		71606560
181	00984		L	MDR,IO,DR	INPUT LO BYTE	71606570
182	00987		L	MDR,IO,DR+CS	INPUT HI BYTE	71606580
183	31189		B	G,ADR	ADRS MODE	71606590
		* MEMORY WRITE				71606600
		*				71606610
184	4068C	DISMEM	L	MR1,MDR,MW	DISPLAY 2	71606620
185	0E22E		C	LOC,LOC,INC+SWA+CMP	INCREMENT LOC	71606630
186	0044C		L	MRO,MAR	DISPLAY 1	71606640
187	02880		LI	MDR,'80'	MEANS ADDRESS	71606650
188	30191		B	OUTDIS		71606660
		*				71606670
		*				71606680
189	00881	ADR	L	MDR,MDR,SR+NC	FORCE LOC TO BE EVEN	71606690
18A	00282		L	LOC,MDR,SL+NC		71606700
18B	30152		B	LOCDIS		71606710
		*				71606720
		*				71606730
18C	00666	PSWLOC	L	MR1,MR1,SL+CO	MS STATUS BIT	71606740
18D	34152		B	C,LOCDIS		71606750
18E	02400		LI	MRO,0	DISPLAY 1	71606760
18F	0060C		L	MR1,PSW	DISPLAY 2	71606770
190	02844		LI	MDR,'44'	FN 4=PSW	71606780
		*				71606790
		* OUTPUT DATA TO DISPLAY				71606800
		*				71606810
191	01860	OUTDIS	L	IO,MR1		71606820
192	01864		L	IO,MR1,DA	MD 8:15	71606830
193	01863		L	IO,MR1,CS		71606840
194	01867		L	IO,MR1,DA+CS	MD 0:7	71606850
195	01840		L	IO,MRO		71606860
196	01844		L	IO,MRO,DA	MA 24:31	71606870
197	01843		L	IO,MRO,CS		71606880
198	01847		L	IO,MRO,DA+CS	MA 16:23	71606890
199	01880		L	IO,MDR		71606900
19A	01884		L	IO,MDR,DA	MA 12:15	71606910
		*				71606920
		* FLIP DISPLAY MODE TO CLEAR COUNTERS				71606930
19B	02680		LI	MR1,'80'		71606940
19C	01860		L	IO,MR1		71606950
19D	01868		L	IO,MR1,CMD	NORMAL	71606960
19E	3015F		B	IDLE		71606970
		*				71606980
		*				71606990
19F	0E236	REGDIS	C	LOC,LOC,CYD+SWA+CMP	CLEAR YD FIELD	71607000
1A0	02C07		LI	AR,'7'		71607010
1A1	0444C		N	MRO,MRO	REGISTER SELECT	71607020
1A2	00666		L	MR1,MR1,SL+CO	MS STATUS BIT	71607030
1A3	0044A		L	MRO,MRO,SL+CI	TO LS POSITION	71607040
1A4	02C01		LI	AR,1		71607050
1A5	0084C		L	MDR,MRO	SAVE REGISTER NO.	71607060
1A6	0C444	REGLP	S	MRO,MRO,CO	DECREMENT NUMBER	71607070
1A7	341AA		B	C,REGS	FOUND	71607080
1A8	0072C		L	MR1,YDP1		71607090

1A9	301A6	B	REG6P		71607100	
		*			71607110	
1AA	004CC	REGS	L	MR0, NULL	DISPLAY 1	71607120
1AB	0070C		L	MR1, Y0	DISPLAY 2	71607130
1AC	02C20		LI	AR, '20'	REGISTER	71607140
1AD	0668C		C	MDR, MDR	NUMBER	71607150
1AE	30191		B	OUTBIS		71607160
		*				71607170
		*				71607180
		*				71607190
		*				71607200
1AF	00584	MODSPL	L	MR0, IO, DR	AUTO-BOOT DEVIC	71607210
1B0	00784		L	MR1, IO, DR	COMMAND	71607220
		*				71607230
1B1	01840		L	IO, MR0		71607240
1B2	01850		L	IO, MR0, ADRS	ADDRESS THE DEVICE	71607250
1B3	01860		L	IO, MR1		71607260
1B4	01868		L	IO, MR1, CMD	OUTPUT COMMAND	71607270
1B5	30107		B	AUTO1		71607280
		*				71607290
		*				71607300
		*				71607310
1B6	80A8C	LPSW	L	MAR, MDR, MR		71607320
1B7	301C5		B	LPSW1	LOAD PSW	71607330
		*				71607340
		*				71607350
1B8	02F00	CONT	LI	FLR, 0	CLEAR FLAGS AND	71607360
1B9	30001		B	START+1	CONTINUE INSTR. FETCH	71607370
		*				71607380
1BA	0E446	TEST	C	MR0, MR0, CMP+SWA	RESLT PARITY ALARM	71607390
1BB	02A38		LI	MAR, 0MPSW		71607400
1BC	389D2		B	HALF, PWRDWN	MUST BE PPF	71607410
1BD	301C1		B	GENSWP	MUST BE MPE+PSW02	71607420
		*				71607430
		*				71607440
1BE	02A40	TEST0	LI	MAR, 0IPSW		71607450
1BF	00E0F		L	FLR, PSW, CS	TEST PSW04	71607460
1C0	342F3		B	C, HSSVC	IMMEDIATE INTERRUPT	71607470
		*				71607480
		*				71607490
		*				71607500
		*				71607510
1C1	4080C	GENSWP	L	MDR, PSW, MW	STORE OLD PSW	71607520
1C2	0EAA8		C	MAR, MAR, INC		71607530
1C3	4082C		L	MDR, LOC, MW	STORE OLD LOC	71607540
1C4	8EAA8		C	MAR, MAR, INC+MR		71607550
		*				71607560
1C5	0EAA8	LPSW1	C	MAR, MAR, INC		71607570
1C6	8008C		L	PSW, MDR, MR	LOAD NEW STATUS	71607580
1C7	00290		L	LOC, MDR, NC+JAM	LOAD NEW LOC & CC	71607590
		*				71607600
1C8	00E0F	TEST1	L	FLR, PSW, CS	TEST PSW06	71607610
1C9	311EC		B	G, QUEBL	QUEUE SERVICE ENABLED	71607620
1CA	00C06	TEST2	L	AR, PSW, SL+CO	TEST PSW00	71607630
1CB	341CD		B	C, WAIT		71607640
1CC	3003F		B	NOB		71607650
		*				71607660

		* INTERRUPTABLE WAIT LOOP			716076 0
		*			716076 0
1CD	0E222	WAIT	C	LOC,LOC,SWA	716076 0
1CE	39156		B	SNGL,DISPLY	716077 0
1CF	3C8FC	WAIT1	B	MALF+ATN,HELP	716077 0
1D0	3A163		B	CATN,IDLEX	716077 0
1D1	301CF		B	WAIT1	716077 0
				LOOP	716077 0
		*			716077 0
		* POWER DOWN			716077 0
		*			716077 0
1D2	02A24	PWRDWN	LI	MAR,APSW	716077 0
1D3	4080C		L	MDR,PSW,MW	716077 0
1D4	301E0		B	PWRDN1	716078 0
				STORE PSW	716078 0
				SKIP PATCH AREA	716078 0
		*			716078 0
		*			716078 0
1D5	02A20	PATCH	LI	MAR,'20'	716078 0
1D6	4086C		L	MDR,MR1,MW	716078 0
1D7	391D9		B	SNGL,CONTIN	716078 0
1D8	30160		B	BACK	716078 0
				SAVE STATUS BIT 0:3 IN CORE	716078 0
				LOCATION X'20' ON EVERY CATN	716078 0
				KEEP GOING IF CATN & SNGL	716078 0
				GO TEST STATUS	716078 0
		*			716078 0
		*			716078 0
1D9	80A2C	CONTIN	L	MAR,LOC,MR	716078 0
1DA	30188		B	CONT	716078 0
1DB	00000		DC	0	716078 0
1DC	00000		DC	0	716078 0
1DD	00000		DC	0	716078 0
1DE	00000		DC	0	716078 0
1DF	00000		DC	0	716078 0
1E0	02A26	PWRDN1	LI	MAR,ALOC	716078 0
1E1	4082C		L	MDR,LOC,MW	716078 0
1E2	0E230		C	LOC,LOC,CYD	716078 0
1E3	82A22		LI	MAR,PNTR,MR	716078 0
1E4	0241E		LI	MRQ,'1E'	716078 0
1E5	02C02		LI	AR,2	716078 0
1E6	00A8C		L	MAR,MDR	716078 0
				STORE LOC	716078 0
				CLEAR YD FIELD	716078 0
				FETCH POINTER	716078 0
				COUNT	716078 0
		*			716078 0
1E7	4092C	STMLP1	L	MDR,YDP1,MW	716080 0
1E8	0C444		S	MR0,MR0,CO	716080 0
1E9	341F7		R	C,POW	716080 0
1EA	0AAA0		A	MAR,MAR,NC	716080 0
1EB	301E7		B	STMLP1	716080 0
				STORE REGISTER	716080 0
				DECREMENT COUNT	716080 0
				DONE	716080 0
				INCREMENT ADRS	716080 0
				LOOP	716080 0
		*			716080 0
		*			716080 0
		*			716080 0
		*			716080 0
1EC	82A80	QUEBL	LI	MAR,'80',MR	716081 0
1ED	02CFF		LI	AR,'FF'	716081 0
1EE	80A8C		L	MAR,MDR,MR	716081 0
1EF	02E00		LI	FLR,0	716081 0
1F0	02A82		LI	MAR,'82'	716081 0
1F1	04C8C		B	AR,MDR	716081 0
1F2	311C1		B	G,GENSWP	716081 0
1F3	301CA		B	TEST2	716081 0
				TEST NO-USED TALLY	716081 0
				NOT EMPTY, DO SWAP	716081 0
				LIST IS EMPTY	716081 0
		*			716081 0
		*			716081 0
		*			716081 0

1F4	020FF	SJNT	L1	AR,FF		71608200
1F5	044AC		N	DR0,MDR	DEVICE NUMBER	71608216
1F6	302F4		R	IOSVC	SIMULATE INTERRUPT	71608220
		*				71608230
		*				71608240
		*				71608250
1F7	0C88C	POD	L	MDR,MDR	WAIT FOR MEMORY	71608260
1F8	0E221		C	LOC,LOC,POW		71608270

Address	Code	Op	Op	Op	Op	Op	Op	Op	Op
									716082 0
		*							716082 0
		* HALFWORD IO							716083 0
		*							716083 0
200	009CC	WHR	L	MDR,YS				OUTPUT TWO BYTES	716083 0
201	01883	WH1	L	IO,MDR,CS				HI BYTE	716083 0
202	01887		L	IO,MDR,CS+DA					716083 0
203	30205		R	WHR1					716083 0
204	009CC	WHR1	L	MDR,YS				OUTPUT ONE HALFWORD	716083 0
205	01880	WHR1	L	IO,MDR					716083 0
206	01884		L	IO,MDR,DA				OUTPUT LO	716083 0
207	00A2C		L	MAR,LOC,IR					716083 0
		*							716084 0
208	00A2C		L	MAR,LOC				EVEN	716084 0
209	30201		R	WH1					716084 0
		*							716084 0
20A	00987	RHR	L	AR,IO,DR+CS				INPUT TWO BYTES	716084 0
20B	30210		L	WHR1					716084 0
20C	30205	WHR1	R	WHR1				OUTPUT ONE HALFWORD	716084 0
		*							716084 0
		*							716084 0
		* 1ST HALFWORD IMMEDIATE							716084 0
		*							716085 0
20D	C4E0C	THI	R	AP,YD,IR					716085 0
		*							716085 0
		*							716085 0
20E	01784	RHRB	L	YS,IO,DR				INPUT ONE HALFWORD	716085 0
20F	00A2C		L	MAR,LOC,IR					716085 0
210	00584	RHR1	L	MRO,IO,DR				INPUT LO	716085 0
211	C764E		O	YS,MRO,NF+IR				COMBINE	716085 0
		*							716085 0
212	00087	RH	L	AR,IO,DR+CS				INPUT TWO BYTES	716085 0
213	00584	RH1	L	MRO,IO,DR				LO BYTE	716085 0
214	4684E		O	MDR,MRO,NF+MW					716086 0
215	C0A2C		L	MAR,LOC,IR					716086 0
		*							716086 0
216	02C00	RHH	LI	AR,0				INPUT ONE HALFWORD	716086 0
217	30213		R	RH1					716086 0
		*							716086 0
		*							716086 0
		* ADD HALFWORD TO MEMORY							716086 0
		*							716086 0
218	00D0C	AHM	L	AR,YD					716087 0
219	4A88C		A	MDR,MDR,MW					716087 0
21A	C0A20		L	MAR,LOC,NC+1R					716087 0
		*							716087 0
		*							716087 0
		* BLOCK IO							716087 0
		*							716087 0
21B	0068C	RWRR	L	MR1,MDR				SAVE INSTR	716087 0
21C	005CC		L	MRO,YS				START ADDR	716087 0
21D	01900		L	IO,YD					716087 0
21E	01910		L	IO,YD,ADRS				ADDRESS THE DEVICE	716087 0
21F	02C0F		LI	AR,'F'					716087 0
220	0E230		C	LOC,LOC,CYD					716087 0
221	0466C		N	MR1,MR1				YS FIELD	716087 0
222	02C01		LI	AR,'1'					716087 0

223	00B2C	RWBR1	L	MAR,YDP1		71608850
224	0C66C		S	MR1,MR1	MAKE YD FIELD	71608860
225	34227		B	C,RWBR2	EQUAL YS FIELD+1	71608870
226	30223		B	RWBR1		71608880
		*				71608890
227	2070C	RWBR2	L	MR1,YD,D2	FINAL ADRS	71608900
		*		VECTOR THRU DROM 2		71608910
		*				71608920
		*				71608930
228	01900	RWBRX	L	IO,YO		71608940
229	01910		L	IO,YD,ADRS	ADDRESS THE DEVICE	71608950
22A	3862C		B	AMOD,RWBXX		71608960
22B	02C00		LI	AR,0		71608970
22C	8AA8C	RWBXX	A	MAR,MDR,MR		71608980
22D	02C02		LI	AR,2		71608990
22E	0048C		L	MRO,MDR	START ADRS	71609000
22F	8AAAC		A	MAR,MAR,MR		71609010
230	0E228		C	LOC,LOC,INC		71609020
231	2068C		L	MR1,MDR,D2	FINAL ADRS	71609030
		*				71609040
		*				71609050
		*				71609060
232	00C4C	WB	L	AR,MRO		71609070
233	0C66C		S	MR1,MR1	START MINUS END	71609080
234	342E0		B	C,FINIS		71609090
235	02C01		LI	AR,1		71609100
236	80A4C		L	MAR,MRO,MR		71609110
237	00F88	LOOPW	L	FLR,IO,STAT		71609120
238	37A3F		B	CVGL,TESTW		71609130
239	01883		L	IO,MDR,CS		71609140
23A	01887		L	IO,MDR,DA+CS	OUTPUT DATA	71609150
23B	0C66C		S	MR1,MR1	DECREMENT COUNT	71609160
23C	342E0		B	C,FINIS	DONE	71609170
23D	8AAAC		A	MAR,MAR,MR	INCREMENT ADRS	71609180
23E	30237		B	LOOPW		71609190
		*				71609200
		*				71609210
23F	33AE1	TESTW	B	VGL,END	BAD STATUS ABORT	71609220
240	34237		B	C,LOOPW	LOOP ON BUSY	71609230
		*				71609240
		*				71609250
241	00C4C	RB	L	AR,MRO		71609260
242	0C66C		S	MR1,MR1	START MINUS END	71609270
243	342E0		B	C,FINIS		71609280
244	02C01		LI	AR,1		71609290
245	80A4C		L	MAR,MRO,MR		71609300
		*				71609310
246	00F88	LOOPR	L	FLR,IO,STAT		71609320
247	37A4E		B	CVGL,TESTR		71609330
248	00983		L	MDR,IO,CS		71609340
249	00987		L	MDR,IO,DR+CS	INPUT DATA	71609350
24A	4C66C	LOOPR1	S	MR1,MR1,MW	DECREMENT COUNT	71609360
24B	342E0		B	C,FINIS	DONE	71609370
24C	8AAAC		A	MAR,MAR,MR	INCREMENT ADRS	71609380
24D	30246		B	LOOPR		71609390
		*				71609400
		*				71609410

24E	33AE1	TESTR	B	VGL,END	BAD STATUS ABORT	71609420
24F	34246		B	C,LOOPR	LOOP ON BUSY	71609430
		*				71609440
		*				71609450
		* MULTIPLY		HALFWORD		71609460
		*				71609470
250	012CC	MH	L	YDP1,NULL	CLEAR HI PRODUCT	71609480
251	02E02		LI	FLR,2		71609490
252	0890E		X	MDR,YD,NF	RESULT SIGN	71609500
253	064CC		O	MRO,NULL	MULTIPLIER	71609510
254	31256		H	G,MH1		71609520
255	0C4CC		S	MRO,NULL	2'S COMP IF NEGATIVE	71609530
256	06D0D	MH1	O	AR,YD,NA	MULTIPLICAND	71609540
257	31259		B	G,MH2		71609550
258	0CCCC		S	AR,NULL	2'S COMP	71609560
259	074CC	MH2	O	YDM1,NULL		71609570
25A	0260F		LI	MR1,15	COUNT	71609580
25B	0130D	MHL	L	YDP1,YD,SR	SHIFT YD,YDP1	71609590
25C	00C4D		L	AR,MRO,NC		71609600
25D	0150D		L	YDM1,YD,SR	RIGHT 1 PLACE	71609610
25E	3426D		B	C,ONE		71609620
25F	02C01	MHL1	LI	AR,1		71609630
260	0C66D		S	MR1,MR1,NC	DECREMENT COUNT	71609640
261	3125B		B	G,MHL		71609650
		*				71609660
262	0130D		L	YDP1,YD,SR		71609670
263	00CCD		L	AR,NULL,NC		71609680
264	0110D		L	YD,YD,SR		71609690
265	0688D		O	MDR,MDR,NA		71609700
266	3126C		B	G,ENDMPY		71609710
267	00D0C		L	AR,YD		71609720
268	0D4C4		S	YDM1,NULL,CO		71609730
269	00CCD		L	AR,NULL,NC		71609740
26A	00D0D		L	AR,YD,NC		71609750
26B	0D0CC		S	YD,NULL		71609760
26C	0E0C	ENDMPY	L	FLR,PSW,IR		71609770
		*				71609780
26D	0B104	ONE	A	YD,YD,CO		71609790
26E	3025F		B	MHL1		71609800
		*				71609810
		*				71609820
		* UNSIGNED MULTIPLY				71609830
		*				71609840
26F	010CC	MHU	L	YD,NULL		71609850
270	064CC		O	MRO,NULL		71609860
271	0260F		LI	MR1,15	COUNT	71609870
272	02801		LI	MDR,1		71609880
273	3025B		B	MHL	COMMON LOOP	71609890
		*				71609900
		*				71609910
		*				71609920
		*				71609930
		* DIVIDE		HALFWORD		71609940
		*				71609950
274	0890E	DH	X	MDR,YD,NF	MDR BIT 0 = RESULT SIGN	71609960
275	00B06		L	MAR,YD,SL+CO		71609970
276	0088E		L	MDR,MDR,SL	MDR BIT 14=DIVIDEND SIGN	71609980

277	008AE		L	MDR,MDR,SL	LEFT IS RESULT SIGN	71609990
		*				71610000
278	06ACC		O	MAP, NULL	DIVISOR	71610010
279	31A7D		B	L,DKDIV	IS NEGATIVE	71610020
280	3127C		B	G,COMSOR	IS POSITIVE	71610030
281	302A9		B	DEFAULT	IS ZERO	71610040
		*				71610050
276	0CACC	COMSOR	S	MAP, NULL	2'S COMP DIVISOR	71610060
270	0652D	DKDIV	O	MR0,YDM1,DA		71610070
27E	00C6C		L	AR,MR1		71610080
27F	0070C		L	MR1,YU		71610090
286	31285		P	G,DH2	DIVIDEND IS POSITIVE	71610100
281	00C6C		L	AR,MR1		71610110
282	0C6CC		S	MR1, NULL	2'S COMP	71610120
283	00C40		L	YR,MR0,NC	DIVIDEND	71610130
284	0C4CC		S	MR0, NULL		71610140
		*				71610150
285	02C03	DH2	LI	AR,3		71610160
286	0488C		N	MDR,MDR	MASK SIGN BITS	71610170
287	08C8C		X	AR,MDR	FLIP	71610180
288	02844		LI	MDR,'44'	COUNT	71610190
289	0688C		O	MDR,MDR	PACK	71610200
		*				71610210
		*				71610220
28A	02C04	DHL	LI	AR,4		71610230
28B	0C884		S	MDR,MDR,CO	DECREMENT COUNT	71610240
28C	34294		B	C,DTST		71610250
28D	00CAC		L	AR,MAP		71610260
28E	0A44C		A	MR0,MR0		71610270
28F	34291		B	C,GOES	OF	71610280
290	0C44C		S	MR0,MR0	RESTORE	71610290
291	0066E	GOES	L	MR1,MR1,SL	SHIFT IN QUOTIENT	71610300
292	0044E		L	MR0,MR0,SL	SHIFT REMAINDER	71610310
293	3028A		B	DHL		71610320
		*				71610330
		*				71610340
294	00445	DTST	L	MR0,MR0,SR+CO	ADJUST REMAINDER	71610350
295	342A9		B	C,DEFAULT		71610360
296	0666D		O	MR1,MR1,NA	TEST QUOTIENT SIGN	71610370
297	30AA4		B	L,STEST	NEGATIVE	71610380
298	00E8C		L	FLR,MDR		71610390
299	30A9D		B	L,DH4	QUOTIENT OK	71610400
29A	00C6C		L	AR,MR1		71610410
29B	0C6CC		S	MR1, NULL	2'S COMP QUOTIENT	71610420
29C	00E8C	DH3	L	FLR,MDR		71610430
29D	312A0	DH4	B	G,DH5	REMAINDER SIGN	71610440
29E	00C4C		L	AR,MR0	SHOULD EQUAL	71610450
29F	0C4CC		S	MR0, NULL	DIVIDEND SIGN	71610460
2A0	0146C	DH5	L	YDM1,MR1	STORE QUOTIENT	71610470
2A1	0104C		L	YD,MR0	STORE REMAINDER	71610480
2A2	00A2C	DHX	L	MAP,LOC		71610490
2A3	00E0C		L	FLR,PSW,IR		71610500
		*				71610510
2A4	00E8C	STEST	L	FLR,MDR		71610520
2A5	30AA9		B	L,DEFAULT		71610530
2A6	00C6C		L	AR,MR1		71610540
2A7	0C6CC		S	MR1, NULL	2'S COMP QUOTIENT	71610550

2A8	30A9C		B	L,OH3	OK IF MINUS	71610540
		*				71610550
		*				71610560
2A9	0040F	DEFAULT	L	MR0,PSW,CS		71610570
2AA	02A48		LI	MAR,DFPSW		71610600
2AB	00E41		L	FLR,MR0,SR+NC	TEST PSW03	71610630
2AC	341C1		B	C,GENSWP	DIVIDE FAULT SWAP	71610670
2AD	302A2		B	DHX		71610690
		*				71610690
		*				71610690
		*				71610690
		*				71610690
		*				71610690
		*				71610690
		*				71610690
		*				71610690
2AE	0C886	SRL	S	MDR,MDR,NF+CO	DECREMENT COUNT	71610690
2AF	342B9		B	C,SRLX		71610700
2B0	00446		L	MR0,MR0,SL+CO		71610710
2B1	0066D		L	MR1,MR1,SR	DO SHIFT	71610720
2B2	2110D		L	YD,YD,SR+D2	LOOP THRU DROM2	71610730
		*				71610740
		*				71610750
2B3	0C886	SRA	S	MDR,MDR,NF+CO		71610760
2B4	342B9		B	C,SRLX		71610770
2B5	00C46		L	AR,MR0,SL+CO		71610780
2B6	0066D		L	MR1,MR1,SR	DO SHIFT	71610790
2B7	0110D		L	YD,YD,SR		71610800
2B8	22C01		LI	AR,1,D2	LOOP THRU DROM2	71610810
		*				71610820
2B9	00446	SRLX	L	MR0,MR0,SL+CO		71610830
2BA	0066D		L	MR1,MR1,SR	COMPENSATE PRE-SHIFT	71610840
2BB	0110D		L	YD,YD,SR		71610850
2BC	302C5		B	SLLX1		71610860
		*				71610870
		*				71610880
2BD	0C886	SLL	S	MDR,MDR,NF+CO	DECREMENT COUNT	71610890
2BE	342C2		B	C,SLLX		71610900
2BF	00445		L	MR0,MR0,SR+CO		71610910
2C0	0110E		L	YD,YD,SL	DO SHIFT	71610920
2C1	2066E		L	MR1,MR1,SL+D2	LOOP THRU DROM2	71610930
		*				71610940
2C2	00445	SLLX	L	MR0,MR0,SR+CO		71610950
2C3	0110E		L	YD,YD,SL	COMPENSATE PRE-SHIFT	71610960
2C4	0066E		L	MR1,MR1,SL	SET CARRY	71610970
2C5	07501	SLLX1	O	YDM1,YD,NA+NC	SET FLAGS	71610980
2C6	0E228		C	LOC,LOC,INC		71610990
2C7	C7061		O	YD,MR1,NA+NC+IR		71611000
		*				71611010
		*				71611020
2C8	0C886	SLAL	S	MDR,MDR,NF+CO	DECREMENT COUNT	71611030
2C9	342CC		B	C,SLAX		71611040
2CA	0110E		L	YD,YD,SL	DO SHIFT	71611050
2CB	2044E		L	MR0,MR0,SL+D2	LOOP THRU DROM2	71611060
		*				71611070
2CC	0750D	SLAX	O	YDM1,YD,NA		71611080
2CD	00C66		L	AR,MR1,SL+CO		71611090
2CE	00CC9		L	AR,NULL,SR+CI	AR=SIGN BIT	71611100
2CF	00446		L	MR0,MR0,SL+CO	CARRY FROM BIT 1	71611110
2D0	00441		L	MR0,MR0,SR+NC		71611120

2D1	0E228		C	LOC,LOC,INC		71611130
2D2	C7040		O	YD,MRO,NC+IR		71611140
		*				71611150
		*				71611160
		*				71611170
2D3	0C886	RRLX	S	MDR,MDR,NF+CO	DECREMENT COUNT	71611180
2D4	342D8		B	C,RRLX		71611190
2D5	0050D		L	MRO,YD,SR	LS BIT TO CARRY	71611200
2D6	0066D		L	MR1,MR1,SR	DO ROTATE	71611210
2D7	2110D		L	YD,YD,SR+D2	LOOP THRU DROM2	71611220
		*				71611230
2D8	0714D	RRLX	O	YD,YDM1,NA	SET G AND L	71611240
2D9	0E228		C	LOC,LOC,INC		71611250
2DA	C706D		O	YD,MR1,NA+IR		71611260
		*				71611270
		*				71611280
		*				71611290
2DB	0C886	RLLL	S	MDR,MDR,NF+CO	DECREMENT COUNT	71611300
2DC	342D8		B	C,RRLX		71611310
2DD	0046E		L	MRO,MR1,SL	MS BIT TO CARRY	71611320
2DE	0110E		L	YD,YD,SL	DO ROTATE	71611330
2DF	2066E		L	MR1,MR1,SL+D2	LOOP THRU DROM2	71611340
		*				71611350
2E0	02E00	FINIS	LI	FLR,0		71611360
2E1	C0A2C	END	L	MAR,LOC,IR	DO NEXT INSTR	71611370
		*				71611380
		*				71611390
2E2	0100C	EPSR	L	YD,PSW	EXCHANGE PSW	71611400
2E3	00CC0		L	AR,NULL,NC	NOP	71611410
2E4	001CC		L	PSW,YS		71611420
2E5	201D0		L	PSW,YS,NC+JAM+D2	TO TEST1	71611430
		*				71611440
		*				71611450
		*				71611460
2E6	008AC	SVC	L	MDR,MAR	A+(X2)	71611470
2E7	42A94		LI	MAR,'94',MW	STORE IT	71611480
2E8	02A96		LI	MAR,'96'		71611490
2E9	02C1E		LI	AR,'1E'		71611500
2EA	4080C		L	MDR,PSW,MW	STORE PSW	71611510
2EB	02A98		LI	MAR,'98'		71611520
2EC	0844C		X	MRO,MRO	UN-COMPLEMENT COUNT	71611530
2ED	4082C		L	MDR,LOC,MW	STORE LOC	71611540
2EE	02C9C		LI	AR,'9C'	MRO=2X YD FIELD	71611550
2EF	82A9A		LI	MAR,'9A',MR		71611560
2F0	0AA40		A	MAR,MRO,NC		71611570
2F1	80080		L	PSW,MDR,NC+MR	NEW PSW	71611580
2F2	C0280		L	LOC,MDR,NC+IR	NEW LOC	71611590
		*				71611600
		*				71611610
2F3	00590	HSSVC	L	MRO,IO,ACK	ACKNOWLEDGE INTERRUPT	71611620
		*				71611630
2F4	02CD0	IOSVC	LI	AR,SPTABL	2X DEVNO INDEXES TABLE	71611640
2F5	0AC40		A	AR,MRO,NC		71611650
2F6	8AA40		A	MAR,MRO,NC+MR	FETCH ENTRY	71611660
2F7	02C02		LI	AR,2		71611670
2F8	00A8C		L	MAR,MDR		71611680
2F9	4080C		L	MDR,PSW,MW	STORE OLD PSW	71611690

2FA	0AAA0	A	MAR,MAR,NC			71611700
2FB	4082C	L	MDR,LOC,MW	STORE OLD LOC		71611710
2FC	8A2A0	A	LOC,MAR,NC+MR			71611720
2FD	0008C	L	PSW,MDR	NEW STATUS		71611730
2FE	CE228	C	LOC,LOC,INC+IR	NEW LOC		71611740
2FF		END				71611750

MICROCODE

ACH	9026
ADR	0159
ADKID	0160
AH	0027
AHM	0218
AI	0049
AIK	0044
AI	0070
ALCC	0026
APSW	0004
ALST	0102
AUT01	0107
AUT02	0108
AUT03	0108
AUT04	0112
AUT05	0118
AUT06	0119
AUT07	0118
AUT08	0120
AUT09	0128
BACP	0160
BAL	0038
BFC	0041
BFER	00A5
BKWD	00AA
BRANCH	003E
BTC	003E
BTER	00AE
BXH	0033
BXLF	0036
BXLH	002A
BXLHX	002C
CH	0020
CLB	0061
CLH	0023
CLRWIT	0170
COMSOR	027C
CONSER	0164
CONT	01B8
CONTIN	0109
DFault	02A9
DFPSW	0048
DH	0274
DH2	0285
DH3	029C
DH4	029D
DH5	02A0
DHL	028A
DHX	02A2
DIEFER	0024
DISMEM	0184
DISPLY	0156
DOB	0042

DOFRB	00A6
DTST	0294
END	02E1
ENDLMI	0145
ENDMPY	026C
EPSR	02E2
EXBR	0068
FINIS	02EG
FN	0177
FRWD	00AB
GENSWP	01C1
GOES	0291
HELP	00FC
HSSVC	02F3
IDLE	015F
IDLE1	0160
IDLEX	0163
ILEG	0008
ILPSW	0030
INAL	0086
IOSVC	02F4
LB	005C
LBR	005A
LCS	001F
LH	001E
LM	00A1
LMLP1	0140
LOCDIS	0152
LOOPR	0246
LOOPR1	024A
LOOPW	0237
LPSW	0106
LPSW1	01C5
MH	0250
MH1	0256
MH2	0259
MHL	025B
MHL1	025F
MHU	026F
MMF	0131
MODE	0171
NH	001B
NOB	003F
NOBRAN	0035
NOCCC	0018
NODSPL	01AF
OC	0079
OH	001C
OIPSW	0040
OKDIV	027D
OMPSW	0038
ONE	026D
OUTDIS	0191
PATCH	01D5
PNTR	0022
POW	01F7
PSWLOC	018C

PWRDN1	01E0
PWRDN	01D2
PWRUP	0100
PWRUP2	0137
PWRUP3	014B
PWRUPX	0103
QUEBL	01EC
RB	0241
RD	006E
RDR	006C
REGDIS	019F
REGLP	01A6
REGS	01AA
RH	0212
RH1	0213
RHH	0216
RHR	020A
RHR1	0210
RHRH	020E
RLLL	02DB
RLR	00F3
RLRX	00F5
RRIO	0046
RRLL	02D3
RRLX	02D8
RS	0003
RSX	0006
RWBR1	0223
RWBR2	0227
RWBRR	021B
RWBRX	0228
RWBXX	022C
RX	000C
RXIO	004B
RXX	0010
SCH	0028
SH	0029
SHORT	0019
SINT	01F4
SL	00EA
SLAL	02C8
SLAX	02CC
SLH	00C8
SLHA	00C6
SLHAL	0009
SLHAX	00DC
SLHLL	0001
SLHLX	00D5
SLHX	00CB
SLL	02BD
SLLS	00CC
SLLX	02C2
SLLX1	02C5
SLX	00EC
SPTABL	00D0
SR	00E0
SRA	02B3

SRH	00H1
SRHA	00BE
SRHL	00BA
SRHLX	00C2
SRHX	00B4
SRL	02AE
SRLS	00B5
SRLX	02B9
SRX	00E2
SS	0075
SSR	0072
START	0000
STB	004D
STB1	0057
STBR	0051
STBX	0050
STEST	02A4
STH	0013
STH1	0016
STHX	0015
STM	009D
STMLM	0090
STMLMX	0099
STMLP1	01E7
SVC	02E6
TEST	01BA
TEST0	01BE
TEST1	01C8
TEST2	01CA
TESTR	024E
TESTW	023F
THI	020D
WAIT	01CD
WAIT1	01CF
WB	0232
WD	0069
WH	0208
WH1	0201
WHH	020C
WHR	0200
WHR1	0205
WHRH	0204
XH	001D

OPT PASS1

* COPYRIGHT INTERDATA INC. NOVEMBER 1973

*

* IRA GABRETT

*

* * * * *

*

* COMMENT FIELD SHOWS OP-CODE AND MNEMONIC AND

* SYMBOLIC ROM ENTRY POINT IN PARENTHESES

*

* LOCATIONS 00 THRU 7F COMPRISE DROM 1

*

*

000	00400	DC	'408'	00	(ILFG)	DRM00030
001	00430	DC	'43B'	00	BALK (BAL)	DRM00040
002	0043E	DC	'43E'	02	BTCR (BTC)	DRM00050
003	00441	DC	'441'	03	BFCR (BFC)	DRM00060
004	0041B	DC	'41B'	04	BHR (BH)	DRM00070
005	00423	DC	'423'	05	CLDR (CLD)	DRM00080
006	0041C	DC	'41C'	06	CHR (CH)	DRM00090
007	0041D	DC	'41D'	07	XHR (XH)	DRM00100
008	0041E	DC	'41E'	08	LHR (LH)	DRM00110
009	00420	DC	'420'	09	CHR (CH)	DRM00120
00A	00427	DC	'427'	0A	AHR (AH)	DRM00130
00B	00429	DC	'429'	0B	SHR (SH)	DRM00140
00C	00408	DC	'408'	0C		DRM00150
00D	00408	DC	'408'	0D		DRM00160
00E	00426	DC	'426'	0E	ACHR (ACH)	DRM00170
00F	00428	DC	'428'	0F	SCHR (SCH)	DRM00180
010	004AE	DC	'4AE'	20	BTBS (BTB)	DRM00190
011	004AE	DC	'4AE'	21	BTFS (BTB)	DRM00200
012	004A5	DC	'4A5'	22	BFBS (BFB)	DRM00210
013	004A5	DC	'4A5'	23	BFFS (BFB)	DRM00220
014	00419	DC	'419'	24	LIS (SHORT)	DRM00230
015	00419	DC	'419'	25	LCS (SHORT)	DRM00240
016	00419	DC	'419'	26	AIS (SHORT)	DRM00250
017	00419	DC	'419'	27	SIS (SHORT)	DRM00260
018	00408	DC	'408'	28	(ILEG)	DRM00270
019	00408	DC	'408'	29	(ILEG)	DRM00280
01A	00408	DC	'408'	2A	(ILEG)	DRM00290
01B	00408	DC	'408'	2B	(ILEG)	DRM00300
01C	00408	DC	'408'	2C	(ILEG)	DRM00310
01D	00408	DC	'408'	2D	(ILEG)	DRM00320
01E	00408	DC	'408'	2E	(ILEG)	DRM00330
01F	00408	DC	'408'	2F	(ILEG)	DRM00340

020	00013	DC	'013'	40	STH (STH)	DRM00490
021	00003	DC	'003'	41	BAL (RS)	DRM00500
022	00003	DC	'003'	42	BTC (RS)	DRM00510
023	00003	DC	'003'	43	BFC (RS)	DRM00520
024	0000C	DC	'00C'	44	NH (RX)	DRM00530
025	0000C	DC	'00C'	45	CLH (RX)	DRM00540
026	0000C	DC	'00C'	46	OH (RX)	DRM00550
027	0000C	DC	'00C'	47	XH (RX)	DRM00560
028	0000C	DC	'00C'	48	LH (RX)	DRM00570
029	0000C	DC	'00C'	49	CH (RX)	DRM00580
02A	0000C	DC	'00C'	4A	AH (RX)	DRM00590
02B	0000C	DC	'00C'	4B	SH (RX)	DRM00600
02C	00408	DC	'408'	4C		DRM00610
02D	00408	DC	'408'	4D		DRM00620
02E	0000C	DC	'00C'	4E	ACH (RX)	DRM00630
02F	0000C	DC	'00C'	4F	SCH (RX)	DRM00640
						DRM00650
030	00408	DC	'408'	60	(ILEG)	DRM00660
031	0004D	DC	'04D'	61	AHM (STB)	DRM00670
032	00408	DC	'408'	62	(ILEG)	DRM00680
033	00408	DC	'408'	63	(ILEG)	DRM00690
034	00408	DC	'408'	64	(ILEG)	DRM00700
035	00408	DC	'408'	65	(ILEG)	DRM00710
036	00408	DC	'408'	66	(ILEG)	DRM00720
037	00408	DC	'408'	67	(ILEG)	DRM00730
038	00408	DC	'408'	68	(ILEG)	DRM00740
039	00408	DC	'408'	69	(ILEG)	DRM00750
03A	00408	DC	'408'	6A	(ILEG)	DRM00760
03B	00408	DC	'408'	6B	(ILEG)	DRM00770
03C	00408	DC	'408'	6C	(ILEG)	DRM00780
03D	00408	DC	'408'	6D	(ILEG)	DRM00790
03E	00408	DC	'408'	6E	(ILEG)	DRM00800
03F	00408	DC	'408'	6F	(ILEG)	DRM00810

040	004B5	DC	'4B5'	90	SRLS (SRLS)	DRM00850
041	004CC	DC	'4CC'	91	SLLS (SLLS)	DRM00840
042	00451	DC	'451'	92	STBR (STBR)	DRM00850
043	0045A	DC	'45A'	93	LBR (LBR)	DRM00850
044	00468	DC	'468'	94	EXBR (EXBR)	DRM00870
045	006E2	DC	'6E2'	95	LPSR (LPSR)	DRM00830
046	0061B	DC	'61B'	96	WBR (RWBR)	DRM00830
047	0061B	DC	'61B'	97	RBR (RWBR)	DRM00900
048	00446	DC	'446'	98	WHR (RRIO)	DRM00910
049	00446	DC	'446'	99	RHR (RRIO)	DRM00920
04A	00446	DC	'446'	9A	WDR (RRIO)	DRM00950
04B	00446	DC	'446'	9B	RDR (RRIO)	DRM00940
04C	00408	DC	'408'	9C		DRM00950
04D	00446	DC	'446'	9D	SSR (RRIO)	DRM00950
04E	00446	DC	'446'	9E	OCR (RRIO)	DRM00970
04F	00444	DC	'444'	9F	AIR (AIR)	DRM00980
						DRM00990
050	00490	DC	'490'	00	STM (STMLM)	DRM01000
051	00490	DC	'490'	01	LM (STMLM)	DRM01010
052	0004D	DC	'04D'	02	STB (STB)	DRM01020
053	0004D	DC	'04D'	03	LB (STB)	DRM01030
054	0004D	DC	'04D'	04	CLB (STB)	DRM01040
055	00003	DC	'003'	05	AL (RS)	DRM01050
056	00228	DC	'228'	06	WB (RWBR)	DRM01050
057	00228	DC	'228'	07	RB (RWBR)	DRM01070
058	0004B	DC	'04B'	08	WH (RXIO)	DRM01080
059	0004B	DC	'04B'	09	RH (RXIO)	DRM01090
05A	0004B	DC	'04B'	0A	WD (RXIO)	DRM01100
05B	0004B	DC	'04B'	0B	RD (RXIO)	DRM01110
05C	00408	DC	'408'	DC		DRM01120
05D	0004B	DC	'04B'	DD	SS (RXIO)	DRM01130
05E	0004B	DC	'04B'	DE	OC (RXIO)	DRM01140
05F	00049	DC	'049'	DF	AI (AI)	DRM01150

*
 * LOCATIONS 80 THRU FF COMPRISE DROM 2
 *

080	00000	DC	0	00		DRM01500
081	00000	DC	0	01	BALR	DRM01500
082	00000	DC	0	02	BTCR	DRM01500
083	00000	DC	0	03	BFCR	DRM01500
084	00000	DC	0	04	NHR	DRM01500
085	00000	DC	0	05	CLHR	DRM01500
086	00000	DC	0	06	UHR	DRM01600
087	00000	DC	0	07	XHR	DRM01600
088	00000	DC	0	08	LHR	DRM01600
089	00000	DC	0	09	CHR	DRM01600
08A	00000	DC	0	0A	AHR	DRM01600
08B	00000	DC	0	0B	SHR	DRM01600
08C	00000	DC	0	0C		DRM01600
08D	00000	DC	0	0D		DRM01600
08E	00000	DC	0	0E	ACHR	DRM01600
08F	00000	DC	0	0F	SCHR	DRM01600
* * *						
090	000AA	DC	'0AA'	20	BTRS (BKWD)	DRM01700
091	000AB	DC	'0AB'	21	BTFS (FRWD)	DRM01700
092	000AA	DC	'0AA'	22	BFBS (BKWD)	DRM01700
093	000AB	DC	'0AB'	23	BFFS (FRWD)	DRM01700
094	0001E	DC	'01E'	24	LIS (LH)	DRM01700
095	0001F	DC	'01F'	25	LCS (LCS)	DRM01700
096	00027	DC	'027'	26	AIS (AH)	DRM01700
097	00029	DC	'029'	27	SIS (SH)	DRM01700
098	00000	DC	0	28		DRM01700
099	00000	DC	0	29		DRM01800
09A	00000	DC	0	2A		DRM01800
09B	00000	DC	0	2B		DRM01800
09C	00000	DC	0	2C		DRM01800
09D	00000	DC	0	2D		DRM01800
09E	00000	DC	0	2E		DRM01800
09F	00000	DC	0	2F		DRM01800

0A0	00016	DC	'016'	40	STH (STH1)	DRM01880
0A1	0003B	DC	'03B'	41	BAL (BAL)	DRM01890
0A2	0003E	DC	'03E'	42	BTC (BTC)	DRM01900
0A3	00041	DC	'041'	43	BFC (BFC)	DRM01910
0A4	0001B	DC	'01B'	44	NH (NH)	DRM01920
0A5	00023	DC	'023'	45	CLH (CLH)	DRM01930
0A6	0001C	DC	'01C'	46	OH (OH)	DRM01940
0A7	0001D	DC	'01D'	47	XH (XH)	DRM01950
0A8	0001E	DC	'01E'	48	LH (LH)	DRM01960
0A9	00020	DC	'020'	49	CH (CH)	DRM01970
0AA	00027	DC	'027'	4A	AH (AH)	DRM01980
0AB	00029	DC	'029'	4B	SH (SH)	DRM01990
0AC	00000	DC	0	4C		DRM02000
0AD	00000	DC	0	4D		DRM02010
0AE	00026	DC	'026'	4E	ACH (ACH)	DRM02020
0AF	00028	DC	'028'	4F	SCH (SCH)	DRM02030
						DRM02040
0B0	00000	DC	0	60		DRM02050
0B1	00218	DC	'218'	61	AHM (AHM)	DRM02060
0B2	00000	DC	0	62		DRM02070
0B3	00000	DC	0	63		DRM02080
0B4	00000	DC	0	64		DRM02090
0B5	00000	DC	0	65		DRM02100
0B6	00000	DC	0	66		DRM02110
0B7	00000	DC	0	67		DRM02120
0B8	00000	DC	0	68		DRM02130
0B9	00000	DC	0	69		DRM02140
0BA	00000	DC	0	6A		DRM02150
0BB	00000	DC	0	6B		DRM02160
0BC	00000	DC	0	6C		DRM02170
0BD	00000	DC	0	6D		DRM02180
0BE	00000	DC	0	6E		DRM02190
0BF	00000	DC	0	6F		DRM02200

0C0	0008A	DC	'08A'	90	SRLS (SRHL)	DRM0222 0
0C1	000D1	DC	'0D1'	91	SLLS (SLHLL)	DRM0222 0
0C2	00018	DC	'018'	92	STBR (NOCCC)	DRM0222 0
0C3	00018	DC	'018'	93	LBR (NOCCC)	DRM0222 0
0C4	00018	DC	'018'	97	EXBR (NOCCC)	DRM0222 0
0C5	001C8	DC	'1C8'	95	EPSR (TEST1)	DRM0222 0
0C6	00232	DC	'232'	96	WBR (WB)	DRM0222 0
0C7	00241	DC	'241'	97	RBR (RB)	DRM0222 0
0C8	00A00	DC	'A00'	98	WHR (WHR)OR(WHRH)	DRM0231 0
0C9	00A0A	DC	'A0A'	99	RHR (RHR)OR(RHRH)	DRM0231 0
0CA	00069	DC	'069'	9A	WDR (WD)	DRM0232 0
0CB	0006C	DC	'06C'	9B	RDR (RDR)	DRM0232 0
0CC	00000	DC	0	9C		DRM0234 0
0CD	00072	DC	'072'	9D	SSR (SSR)	DRM0235 0
0CE	00079	DC	'079'	9E	OCR (OC)	DRM0235 0
0CF	00072	DC	'072'	9F	AIR (SSR)	DRM0237 0
0D0	0009D	DC	'09D'	D0	STM (STM)	DRM0235 0
0D1	000A1	DC	'0A1'	D1	LM (LM)	DRM0241 0
0D2	00057	DC	'057'	D2	STB (STB1)	DRM0241 0
0D3	0005C	DC	'05C'	D3	LB (LB)	DRM0242 0
0D4	00061	DC	'061'	D4	CLB (CLB)	DRM0242 0
0D5	0007C	DC	'07C'	D5	AL (AL)	DRM0244 0
0D6	00232	DC	'232'	D6	WB (WB)	DRM0245 0
0D7	00241	DC	'241'	D7	RB (RB)	DRM0245 0
0D8	00A08	DC	'A08'	D8	WH (WH)OR(WHH)	DRM0247 0
0D9	00A12	DC	'A12'	D9	RH (RH)OR(RHH)	DRM0248 0
0DA	00069	DC	'069'	DA	WD (WD)	DRM0249 0
0DB	0006E	DC	'06E'	DB	RD (RD)	DRM0250 0
0DC	00000	DC	0	DC		DRM0251 0
0DD	00075	DC	'075'	DD	SS (SS)	DRM0252 0
0DE	00079	DC	'079'	DE	OC (OC)	DRM0253 0
0DF	00075	DC	'075'	DF	AI (SS)	DRM0254 0

OE0	00033	DC	'033'	C0	BXH (BXH)	DRM02560
OE1	00036	DC	'036'	C1	BXLE (BXLE)	DRM02570
OE2	001B6	DC	'1B6'	C2	LPSW (LPSW)	DRM02580
OE3	0020D	DC	'20D'	C3	THI (THI)	DRM02590
OE4	0001B	DC	'01B'	C4	NHI (NH)	DRM02600
OE5	00023	DC	'023'	C5	CLHI (CLH)	DRM02610
OE6	0001C	DC	'01C'	C6	OHI (OH)	DRM02620
OE7	0001D	DC	'01D'	C7	XHI (XH)	DRM02630
OE8	0001E	DC	'01E'	C8	LHI (LH)	DRM02640
OE9	00020	DC	'020'	C9	CHI (CH)	DRM02650
OE9A	00027	DC	'027'	CA	AHI (AH)	DRM02660
OE9B	00029	DC	'029'	CB	SHI (SH)	DRM02670
OE9C	000BA	DC	'0BA'	CC	SRHL (SRHL)	DRM02680
OE9D	000D1	DC	'0D1'	CD	SLHL (SLHL)	DRM02690
OE9E	000BE	DC	'0BE'	CE	SRHA (SRHA)	DRM02700
OE9F	000D9	DC	'0D9'	CF	SLHA (SLHAL)	DRM02710
*						
OF0	00000	DC	0	E0		DRM02720
OF1	002E6	DC	'2E6'	E1	SVC (SVC)	DRM02730
OF2	001F4	DC	'1F4'	E2	SINT (SINT)	DRM02740
OF3	00000	DC	0	E3		DRM02750
OF4	00000	DC	0	E4		DRM02760
OF5	00000	DC	0	E5		DRM02770
OF6	00000	DC	0	E6		DRM02780
OF7	00000	DC	0	E7		DRM02790
OF8	00000	DC	0	E8		DRM02800
OF9	00000	DC	0	E9		DRM02810
OF9A	002D3	DC	'2D3'	EA	RRL (RRL)	DRM02820
OF9B	002DB	DC	'2DB'	EB	RLL (RLL)	DRM02830
OF9C	002AE	DC	'2AE'	EC	SRL (SRL)	DRM02840
OF9D	002BD	DC	'2BD'	ED	SLL (SLL)	DRM02850
OF9E	002B3	DC	'2B3'	EE	SRA (SRA)	DRM02860
OF9F	002C8	DC	'2C8'	EF	SLA (SLAL)	DRM02870

OPT PASS1

* COPYRIGHT INTERDATA INC. NOVEMBER 1973

*
* IRA GABBERT

*
* * * * *

* COMMENT FIELD SHOWS OP-CODE AND MNEMONIC AND
* SYMBOLIC ROM ENTRY POINT IN PARENTHESIS

* LOCATIONS 00 THRU 7F COMPRISE DROM 1

000	00408	DC	'408'	00	(ILEG)	DRM00050
001	0043B	DC	'43B'	00	BALK (BAL)	DRM00040
002	0043E	DC	'43E'	02	BTCR (BTCR)	DRM00050
003	00441	DC	'441'	03	BFCR (BFC)	DRM00060
004	0041B	DC	'41B'	04	NHR (NH)	DRM00070
005	00423	DC	'423'	05	CLHR (CLH)	DRM00080
006	0041C	DC	'41C'	06	OHR (OH)	DRM00090
007	0041D	DC	'41D'	07	XHR (XH)	DRM00100
008	0041E	DC	'41E'	08	LHR (LH)	DRM00110
009	00420	DC	'420'	09	CHR (CH)	DRM00120
00A	00427	DC	'427'	0A	AHR (AH)	DRM00130
00B	00429	DC	'429'	0B	SHR (SH)	DRM00140
00C	00650	DC	'650'	0C	MHR (MH)	DRM00150
00D	00674	DC	'674'	0D	DHR (DH)	DRM00160
00E	00426	DC	'426'	0E	ACHR (ACH)	DRM00170
00F	00428	DC	'428'	0F	SCHR (SCH)	DRM00180
010	004AE	DC	'4AE'	20	BTBS (BTFR)	DRM00190
011	004AE	DC	'4AE'	21	BTFS (BTFR)	DRM00200
012	004A5	DC	'4A5'	22	BFBS (BFFR)	DRM00210
013	004A5	DC	'4A5'	23	BFFS (BFFR)	DRM00220
014	00419	DC	'419'	24	LIS (SHORT)	DRM00230
015	00419	DC	'419'	25	LCS (SHORT)	DRM00240
016	00419	DC	'419'	26	AIS (SHORT)	DRM00250
017	00419	DC	'419'	27	SIS (SHORT)	DRM00260
018	00408	DC	'408'	28	(ILEG)	DRM00270
019	00408	DC	'408'	29	(ILEG)	DRM00280
01A	00408	DC	'408'	2A	(ILEG)	DRM00290
01B	00408	DC	'408'	2B	(ILEG)	DRM00300
01C	00408	DC	'408'	2C	(ILEG)	DRM00310
01D	00408	DC	'408'	2D	(ILEG)	DRM00320
01E	00408	DC	'408'	2E	(ILEG)	DRM00330
01F	00408	DC	'408'	2F	(ILEG)	DRM00340

020	00013	DC	'013'	40	STH (STH)	DRM00490
021	00003	DC	'003'	41	BAL (RS)	DRM00500
022	00003	DC	'003'	42	BTC (RS)	DRM00510
023	00003	DC	'003'	43	BFC (RS)	DRM00520
024	0000C	DC	'00C'	44	NH (RX)	DRM00530
025	0000C	DC	'00C'	45	CLH (RX)	DRM00540
026	0000C	DC	'00C'	46	OH (RX)	DRM00550
027	0000C	DC	'00C'	47	XH (RX)	DRM00560
028	0000C	DC	'00C'	48	LH (RX)	DRM00570
029	0000C	DC	'00C'	49	CH (RX)	DRM00580
02A	0000C	DC	'00C'	4A	AH (RX)	DRM00590
02B	0000C	DC	'00C'	4B	SH (RX)	DRM00600
02C	0000C	DC	'00C'	4C	MH (RX)	DRM00610
02D	0000C	DC	'00C'	4D	DH (RX)	DRM00620
02E	0000C	DC	'00C'	4E	ACH (RX)	DRM00630
02F	0000C	DC	'00C'	4F	SCH (RX)	DRM00640
						DRM00650
030	00408	DC	'408'	60	(ILEG)	DRM00660
031	0004D	DC	'04D'	61	AHM (STB)	DRM00670
032	00408	DC	'408'	62	(ILEG)	DRM00680
033	00408	DC	'408'	63	(ILEG)	DRM00690
034	00408	DC	'408'	64	(ILEG)	DRM00700
035	00408	DC	'408'	65	(ILEG)	DRM00710
036	00408	DC	'408'	66	(ILEG)	DRM00720
037	00408	DC	'408'	67	(ILEG)	DRM00730
038	00408	DC	'408'	68	(ILEG)	DRM00740
039	00408	DC	'408'	69	(ILEG)	DRM00750
03A	00408	DC	'408'	6A	(ILEG)	DRM00760
03B	00408	DC	'408'	6B	(ILEG)	DRM00770
03C	00408	DC	'408'	6C	(ILEG)	DRM00780
03D	00408	DC	'408'	6D	(ILEG)	DRM00790
03E	00408	DC	'408'	6E	(ILEG)	DRM00800
03F	00408	DC	'408'	6F	(ILEG)	DRM00810

040	004B5	DC	'4B5'	90	SRLS (SRLS)	DRM00830
041	004CC	DC	'4CC'	91	SLLS (SLLS)	DRM00840
042	00451	DC	'451'	92	STBR (STBR)	DRM00850
043	0045A	DC	'45A'	93	LBR (LBR)	DRM00860
044	00468	DC	'468'	94	EXBR (EXBR)	DRM00870
045	006E2	DC	'6E2'	95	EPSR (EPSR)	DRM00880
046	0061B	DC	'61B'	96	WBR (RWBR)	DRM00890
047	0061B	DC	'61B'	97	RBR (RWBR)	DRM00900
048	00446	DC	'446'	98	WHR (KRIO)	DRM00910
049	00446	DC	'446'	99	RHR (KRIO)	DRM00920
04A	00446	DC	'446'	9A	WDR (KRIO)	DRM00930
04B	00446	DC	'446'	9B	RDR (KRIO)	DRM00940
04C	0066F	DC	'66F'	9C	MHUR (MHU)	DRM00950
04D	00446	DC	'446'	9D	SSR (KRIO)	DRM00960
04E	00446	DC	'446'	9E	OCR (KRIO)	DRM00970
04F	00444	DC	'444'	9F	AIR (AIR)	DRM00980
						DRM00990
050	00490	DC	'490'	00	STM (STMLM)	DRM01000
051	00490	DC	'490'	01	LM (STMLM)	DRM01010
052	00040	DC	'040'	02	STB (STB)	DRM01020
053	00040	DC	'040'	03	LB (STB)	DRM01030
054	00040	DC	'040'	04	CLB (STB)	DRM01040
055	00003	DC	'003'	05	AL (RS)	DRM01050
056	00228	DC	'228'	06	WB (RWBRX)	DRM01060
057	00228	DC	'228'	07	RB (RWBRX)	DRM01070
058	0004B	DC	'04B'	08	WH (RXIO)	DRM01080
059	0004B	DC	'04B'	09	RH (RXIO)	DRM01090
05A	0004B	DC	'04B'	0A	WD (RXIO)	DRM01100
05B	0004B	DC	'04B'	0B	RD (RXIO)	DRM01110
05C	0000C	DC	'00C'	0C	MHU (RX)	DRM01120
05D	0004B	DC	'04B'	0D	SS (RXIO)	DRM01130
05E	0004B	DC	'04B'	0E	UC (RXIO)	DRM01140
05F	00049	DC	'049'	0F	AI (AI)	DRM01150

060	0002A	DC	'02A'	C0	BXH (BXLH)	DRM01170
061	0002A	DC	'02A'	C1	BXLE (BXLH)	DRM01180
062	00003	DC	'003'	C2	LPSW (RS)	DRM01190
063	00003	DC	'003'	C3	THI (RS)	DRM01200
064	00003	DC	'003'	C4	NHI (RS)	DRM01210
065	00003	DC	'003'	C5	CLHI (RS)	DRM01220
066	00003	DC	'003'	C6	OHI (RS)	DRM01230
067	00003	DC	'003'	C7	XHI (RS)	DRM01240
068	00003	DC	'003'	C8	LH (RS)	DRM01250
069	00003	DC	'003'	C9	CHI (RS)	DRM01260
06A	00003	DC	'003'	CA	AHI (RS)	DRM01270
06B	00003	DC	'003'	CB	SHI (RS)	DRM01280
06C	000B1	DC	'0B1'	CC	SRHL (SRH)	DRM01290
06D	000C8	DC	'0C8'	CD	SLHL (SLH)	DRM01300
06E	000B1	DC	'0B1'	CE	SRHS (SRH)	DRM01310
06F	000C6	DC	'0C6'	CF	SLHA (SLHA)	DRM01320
070	00408	DC	'408'	E0	(ILEG)	DRM01330
071	00490	DC	'490'	E1	SVC (STMLM)	DRM01340
072	00003	DC	'003'	E2	SINT (RS)	DRM01350
073	00408	DC	'408'	E3	(ILEG)	DRM01360
074	00408	DC	'408'	E4	(ILEG)	DRM01370
075	00408	DC	'408'	E5	(ILEG)	DRM01380
076	00408	DC	'408'	E6	(ILEG)	DRM01390
077	00408	DC	'408'	E7	(ILEG)	DRM01400
078	00408	DC	'408'	E8	(ILEG)	DRM01410
079	00408	DC	'408'	E9	(ILEG)	DRM01420
07A	000F3	DC	'0F3'	EA	RRL (RLR)	DRM01430
07B	000F3	DC	'0F3'	EB	KLL (RLR)	DRM01440
07C	000E0	DC	'0E0'	EC	SRL (SR)	DRM01450
07D	000EA	DC	'0EA'	ED	SLL (SL)	DRM01460
07E	000E0	DC	'0E0'	EE	SRA (SR)	DRM01470
07F	000F3	DC	'0F3'	EF	SLA (RLR)	DRM01480

*
 * LOCATIONS 80 THRU FF COMPRISE DROM 2
 *

080	00000	DC	0	00	DRM01510
081	00000	DC	0	01 BALR	DRM01520
082	00000	DC	0	02 BTCR	DRM01530
083	00000	DC	0	03 BFCR	DRM01540
084	00000	DC	0	04 NHR	DRM01550
085	00000	DC	0	05 CLHR	DRM01560
086	00000	DC	0	06 OHR	DRM01570
087	00000	DC	0	07 XHR	DRM01580
088	00000	DC	0	08 LHR	DRM01590
089	00000	DC	0	09 CHR	DRM01600
08A	00000	DC	0	0A AHR	DRM01610
08B	00000	DC	0	0B SHR	DRM01620
08C	00000	DC	0	0C MHR	DRM01630
08D	00000	DC	0	0D DHR	DRM01640
08E	00000	DC	0	0E ACHR	DRM01650
08F	00000	DC	0	0F SCHR	DRM01660
*					
090	000AA	DC	'0AA'	20 BTBS (BKWD)	DRM01700
091	000AB	DC	'0AB'	21 BTFS (FRWD)	DRM01710
092	000AA	DC	'0AA'	22 BFBS (BKWD)	DRM01720
093	000AB	DC	'0AB'	23 BFFS (FRWD)	DRM01730
094	0001E	DC	'01E'	24 LIS (LH)	DRM01740
095	0001F	DC	'01F'	25 LCS (LCS)	DRM01750
096	00027	DC	'027'	26 AIS (AH)	DRM01760
097	00029	DC	'029'	27 SIS (SH)	DRM01770
098	00000	DC	0	28	DRM01780
099	00000	DC	0	29	DRM01790
09A	00000	DC	0	2A	DRM01800
09B	00000	DC	0	2B	DRM01810
09C	00000	DC	0	2C	DRM01820
09D	00000	DC	0	2D	DRM01830
09E	00000	DC	0	2E	DRM01840
09F	00000	DC	0	2F	DRM01850

0C0	0000A	DC	'00A'	90	SRLS (SRHL)	DRM02290
0C1	00001	DC	'001'	91	SLLS (SLHLL)	DRM02291
0C2	00018	DC	'018'	92	STBR (NOCCC)	DRM02292
0C3	00018	DC	'018'	93	LBR (NOCCC)	DRM02293
0C4	00018	DC	'018'	97	EXBR (NOCCC)	DRM02297
0C5	00108	DC	'108'	95	LPSR (TEST1)	DRM02295
0C6	00232	DC	'232'	96	WBR (WB)	DRM02296
0C7	00241	DC	'241'	97	RBR (RB)	DRM02297
0C8	00A00	DC	'A00'	98	WHF (WHR)OR(WHRH)	DRM02300
0C9	00A0A	DC	'A0A'	99	RHR (RHR)OR(RHRH)	DRM02301
0CA	00069	DC	'069'	9A	WDR (WD)	DRM02302
0CB	0006C	DC	'06C'	9B	RDR (RDR)	DRM02303
0CC	00000	DC	'0'	9C	MHUR	DRM02304
0CD	00072	DC	'072'	9D	SSR (SSR)	DRM02305
0CE	00079	DC	'079'	9E	OCR (OC)	DRM02306
0CF	00072	DC	'072'	9F	AIR (SSR)	DRM02307
0D0	0009D	DC	'09D'	00	STM (STM)	DRM02308
0D1	000A1	DC	'0A1'	01	LM (LM)	DRM02401
0D2	00057	DC	'057'	02	STB (STB1)	DRM02402
0D3	0005C	DC	'05C'	03	LB (LB)	DRM02403
0D4	00061	DC	'061'	04	CLB (CLB)	DRM02404
0D5	0007C	DC	'07C'	05	AL (AL)	DRM02405
0D6	00232	DC	'232'	06	WB (WB)	DRM02406
0D7	00241	DC	'241'	07	RB (RB)	DRM02407
0D8	00A08	DC	'A08'	08	WH (WH)OR(WHH)	DRM02408
0D9	00A12	DC	'A12'	09	RH (RH)OR(RHH)	DRM02409
0DA	00069	DC	'069'	0A	WD (WD)	DRM0240A
0DB	0006E	DC	'06E'	0B	RD (RD)	DRM0250B
0DC	0026F	DC	'26F'	0C	MHU (MHU)	DRM0250C
0DD	00075	DC	'075'	0D	SS (SS)	DRM0250D
0DE	00079	DC	'079'	0E	OC (OC)	DRM0250E
0DF	00075	DC	'075'	0F	AI (SS)	DRM0250F

0E0	00033	DC	'033'	C0	BXH (BXH)	DRM02560
0E1	00036	DC	'036'	C1	BXLE (BXLE)	DRM02570
0E2	00186	DC	'186'	C2	LPSW (LPSW)	DRM02580
0E3	00200	DC	'200'	C3	THI (THI)	DRM02590
0E4	00018	DC	'018'	C4	NHI (NH)	DRM02600
0E5	00023	DC	'023'	C5	CLHI (CLH)	DRM02610
0E6	0001C	DC	'01C'	C6	OHI (OH)	DRM02620
0E7	00010	DC	'010'	C7	XHI (XH)	DRM02630
0E8	0001E	DC	'01E'	C8	LHI (LH)	DRM02640
0E9	00020	DC	'020'	C9	CHI (CH)	DRM02650
0EA	00027	DC	'027'	CA	AHI (AH)	DRM02660
0EB	00029	DC	'029'	CB	SHI (SH)	DRM02670
0EC	000BA	DC	'0BA'	CC	SRHL (SRHL)	DRM02680
0ED	000D1	DC	'0D1'	CD	SLHL (SLHLL)	DRM02690
0EE	000BE	DC	'0BE'	CE	SRHA (SRHA)	DRM02700
0EF	000D9	DC	'0D9'	CF	SLHA (SLHAL)	DRM02710
						DRM02720
0F0	00000	DC	0	E0		DRM02730
0F1	002E6	DC	'2E6'	E1	SVC (SVC)	DRM02740
0F2	001F4	DC	'1F4'	E2	SINT (SINT)	DRM02750
0F3	00000	DC	0	E3		DRM02760
0F4	00000	DC	0	E4		DRM02770
0F5	00000	DC	0	E5		DRM02780
0F6	00000	DC	0	E6		DRM02790
0F7	00000	DC	0	E7		DRM02800
0F8	00000	DC	0	E8		DRM02810
0F9	00000	DC	0	E9		DRM02820
0FA	002D3	DC	'2D3'	EA	RRL (RRL)	DRM02830
0FB	002D8	DC	'2D8'	EB	RLL (RLL)	DRM02840
0FC	002AE	DC	'2AE'	EC	SRL (SRL)	DRM02850
0FD	002BD	DC	'2BD'	ED	SLL (SLL)	DRM02860
0FE	002B3	DC	'2B3'	EE	SRA (SRA)	DRM02870
0FF	002C8	DC	'2C8'	EF	SLA (SLA)	DRM02880

100 END DRM02890

DISPLAY PANEL



M71-102

HEXADECIMAL DISPLAY

INFORMATION SPECIFICATION

1. INTRODUCTION

The optional Hexadecimal Display Panel provides a means to manually control the Processor, interrogate and display various Processor registers and machine status, set and display Processor memory locations, and may be programmed as an I/O device by the user.

This specification describes the 09-065F02 Hexadecimal Display Panel (Product Number M71-102). It is also applicable to the 09-065F01 Binary Display Panel (Product Number M71-101), which is identical to the Hexadecimal Display Panel except for the omission of the hexadecimal indicators. The Hexadecimal Display Panel provides the following functions:

Displays five bytes of programmable digital information.

Registers and displays five hexadecimal digits of manually entered keyboard data.

Displays the WAIT and Power (PWR) indicators for the Processor.

Provides a 26 key control keyboard for manual input to the display.

Provides two bytes of unbuffered Switch Register data to the Processor.

Provides one byte of status to the Processor.

Provides a three position OFF-ON-LOCK key type switch capable of switching three separate power supply control lines.

Provides a control signal to the Processor that the display requires micro-program support.

2. GENERAL DESCRIPTION

A complete description of the operation of the Hexadecimal Display Panel is provided in the appropriate User's Manual. This specification describes the display from a maintenance view point. Figure 1 shows the Hexadecimal Display Panel.

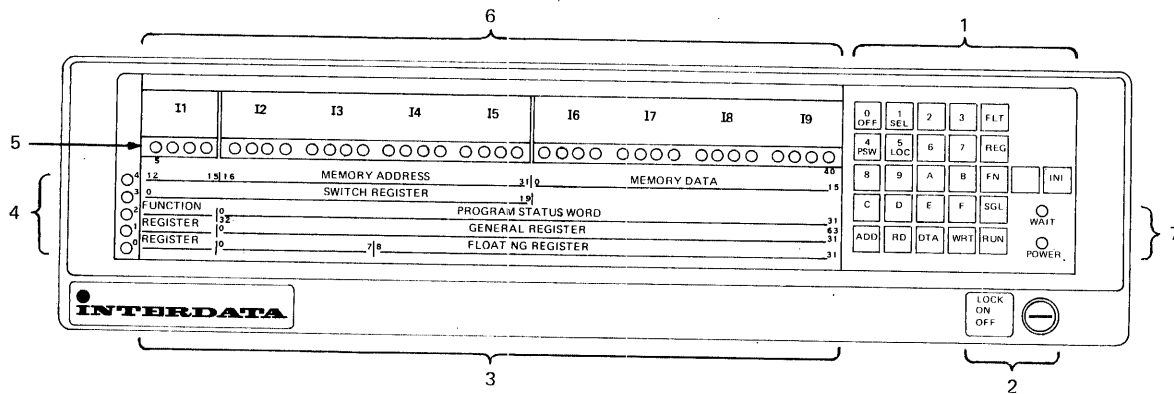

Figure 1. Hexadecimal Display Panel

Various parts of the Hexadecimal Display Panel in Figure 1 are numbered to correlate to the following descriptions.

1. Control Keyboard. The keyboard is the operators manual input to the Processor. The function of the specific keys are:

DTA The function of the Data (DTA) key is to clear the Switch Register, connect the Switch Register to the display indicators, and enable hexadecimal data to be entered into the register. The Switch Register remains enabled and connected to the display indicators until any non-hexadecimal key other than DTA is depressed.

Hexadecimal Keys 0, 1, 2, 3, 4, 5, 6, 7, 8, 9, A, B, C, D, E, and F supply data to the Switch Register when it is enabled, and the function number or register number for the Processor supported display (see Section 2.2).

- ADD** The Address (ADD) key causes the Processor to read the five hexadecimal characters of the Switch Register, store them in the address portion of the Program Status Word (PSW), and display PSW 32:63 on the indicators.
- RD** The Read (RD) key causes the Processor to read the memory location specified by the PSW, increment the PSW address by two, and display on the indicators the new address and the data read from memory.
- WRT** Depressing the Write (WRT) key causes the data contained in the Switch Register to be written into the address specified by the PSW, the PSW to be incremented by two, and the new address and the data written to be displayed on the indicators.
- FLT** Depressing the Floating-Point Register (FLT) key, followed by any hexadecimal key n, causes Floating-Point Register n to be displayed on the indicators.
- REG** Depressing the Register (REG) key, followed by any hexadecimal key n, causes general register n to be displayed.
- FN** Depressing the Function (FN) key, followed by any hexadecimal key n, causes the Processor to perform "Function n" as described in the appropriate User's Manual.
- SGL** Depressing the Single Step (SGL) key causes the Processor to execute one user instruction and display the last register or function selected.
- RUN** Depressing the Run (RUN) key causes the Processor to enter the Run mode at the address specified by the PSW.
- INI** Depressing the Initialize (INI) key initializes the Processor.

NOTE

The display requires support from the micro-program for all functions other than entering or displaying Switch Register data.

2. OFF-ON-LOCK Key Operated Locking Switch. This switch controls the power to the Processor and allows the keyboard to be completely disabled in the LOCK position.

3. Indicator Formats. These formats aid the user in interpreting the display indicators.

4. Format Selectors L0:4. Light Emitting Diode (LED) indicators L0:4 determine the format to be used to interpret display indicators L5:40.

5. Display Indicators L5:40. These LED indicators are used to display the PSW, general registers, etc., as described by the indicator formats.

6. Display Indicators I1:9. These indicators display the corresponding values displayed on L5:40 in the hexadecimal format.

7. WAIT and PWR. These indicators are illuminated when Processor is in the Wait state and Power is supplied to the Processor.

2.1 Switch Register Entries

When the operator is manipulating the Switch Register, there is no interaction between the display and the Processor. Data is entered into this register by first depressing the DTA key. This operation clears the Switch Register; connects the Switch Register to L5:24 of the display, and allows subsequent hexadecimal keyboard entries to be left shifted into the least significant digit of the register. The register is disconnected from the display and disabled when any non-hexadecimal key other than DTA is depressed. The register can be momentarily examined when it is disabled without affecting the Processor operation by depressing any hexadecimal key.

2.2 Processor Intervention

Depressing the following single keys causes the signals ESNC0 and ESNO0 to be complementarily pulsed (ESNC0 is a positive going pulse):

ADD
RD
WRT
SGL
RUN

Depressing one of the following sequences of two keys causes a similar action:

FLT n (n is any hexadecimal digit)
REG n
FN n

3. FUNCTIONAL DIAGRAM ANALYSIS AND CIRCUIT DESCRIPTION

Refer to Figure 2. Hexadecimal Display Panel Block Diagram and Functional Schematic 09-065D08.

3.1 OFF-ON-LOCK Switch

This switch (2K1) controls power to the Processor by completing the circuit between CONT2 and CONT1 in the ON and LOCK positions. The switch is factory wired to provide one set of closures, but two additional sets are available for switching power supplies connected to different phased AC power. This switch also provides a hard ground to the Processor as POFF0 in the OFF position which may be used as an early power down indication. When the switch is in the ON position, LP5 (2L1) is provided to the keyboard to enable the sensing of these switch closures.

3.2 Keyboard

The keyboard (Sheet 2) has a 5 x 5 switch array which is used to enter information to the Hexadecimal Display Panel logic, plus an Initialize (INI) key used to transmit this condition to the Processor (2G1). The keyboard is a self-contained unit and connects to the 35-520 logic board by 27 stakes 00-1 through 26-1. These normally open switches are encoded by diode logic (Sheet 2) to form HEX01:31 (2B8) and FUN00:30 (2C8), plus a few additional control signals mentioned later in this description. The switches are designed to be high active when a switch is depressed by biasing all receiving gates low with a 220 ohm input resistor. A switch being depressed causes an input gate to go high by supplying LP5 through a current limiting resistor from the common input, Pin 0, if the OFF-ON-LOCK switch is in the ON position. There is no keyboard rollover protection and if more than one key is simultaneously depressed, the result is unspecified.

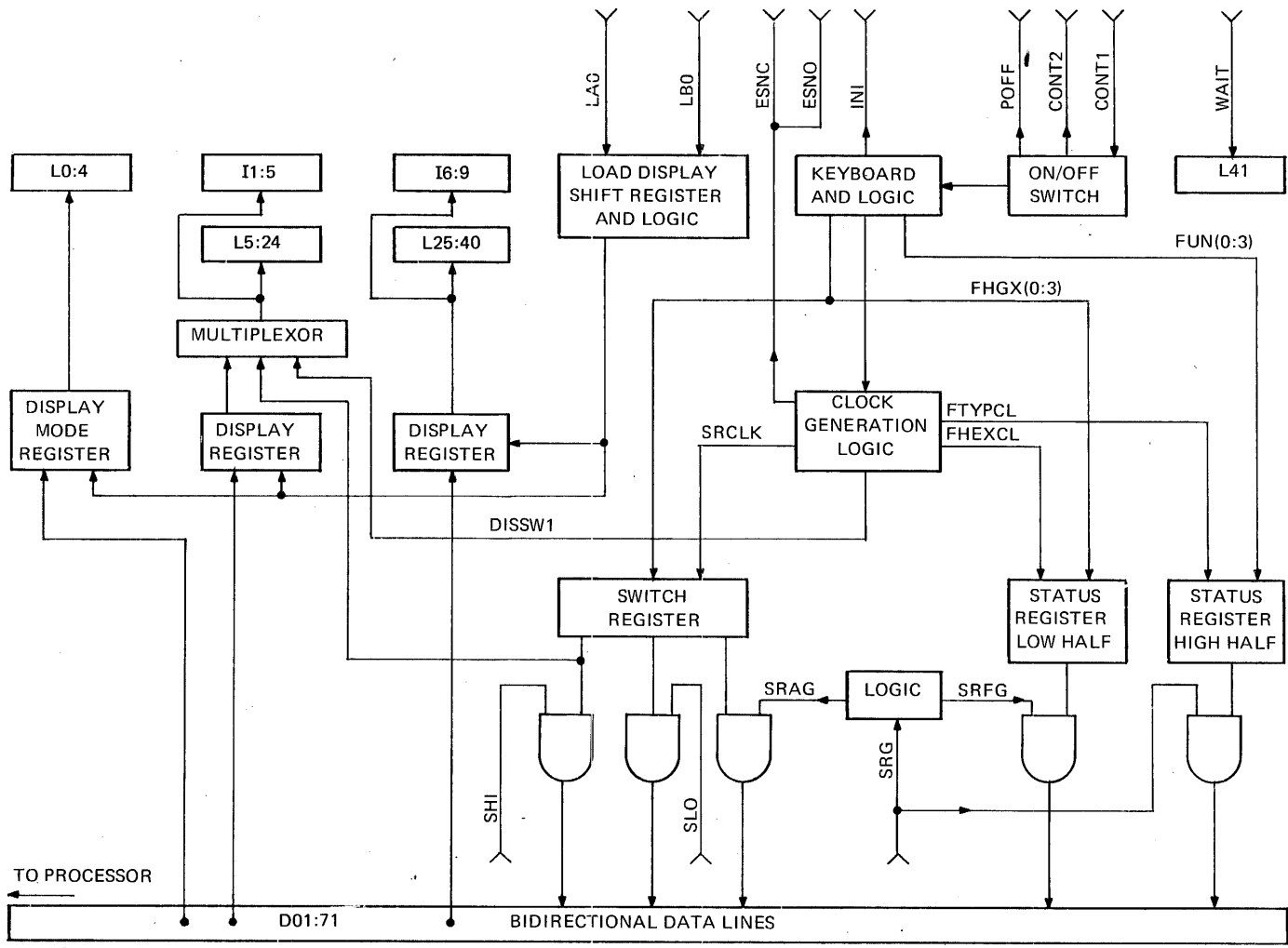

Figure 2. Hexadecimal Display Panel Block Diagram

3.3 Matrix Encoding

The diode matrix is encoded to drive signals HEX01:31 to the hexadecimal equivalent of the respective key 0:F (HEX31 is the LSB) when it is depressed. Depressing any function key other than DTA causes FUN00:30 to yield the codes specified by Table 1.

TABLE 1. FUNCTION KEY ENCODING (FUN00:30)

Key Depressed	FUN00	FUN10	FUN20	FUN30
SGL	0	1	1	1
RUN	1	1	1	1
WRT	1	1	0	1
RD	1	0	1	1
ADD	1	0	0	1
REG	0	1	1	0
FLT	0	1	0	0
FN	0	1	1	1

3.4 Clocking

Depressing any keyboard key other than DTA or INI generates one of three types of clocks used by the Hexadecimal Display Panel logic. This is accomplished by a positive transition of signal KEY1 (2F8) whenever one of these keys is depressed. The one shot triggered by this transition (2G8) is used to allow a one to two millisecond interval for switch bounce to subside before triggering the second one shot STRB1 (2K8) which is used to generate one of the three clocks. Since contact bounce is likely to retrigger these one shots when a key is released, the occurrence of signal KEY1 (any key depressed), HKEY1 (2F9 a hexadecimal key depressed), or FKEY1 (2H7 a function key depressed) being true in coincidence with the one shot is used to derive the clocks.

3.5 Switch Register Clocks

The Switch Register is enabled for clocking by depressing the DTA key. This is accomplished by direct clearing the Switch Register Enable flip-flop (SRENB) (2L6) when DTA is depressed and ANDing the zero output of the flip-flop plus HKEY1 and STRB1 to drive the Switch Register Clock (SRCLK0) (2M7). This clock is disabled by setting SRENB with the occurrence of FKEY1 when any function key is depressed.

3.6 Status Register Clocks

Two different clocks are used to load the status register. FTYPCLO (2M8) is generated whenever any function key other than DTA is depressed and is used to load FUN00:30 into one half of the status register. The second clock FHEXCLO (2N8) is generated whenever a hexadecimal key is depressed if the previously depressed key was FN, REG, or FLT. In this case, the hexadecimal input would be the register number or function number desired and FHEXCLO is used to clock HEX01:31 into the second half of the status register.

3.7 Processor Intervention

The logic of the display signals the Processor that a response is necessary to a console function by signal ESNC0 (2R7) and its compliment ESNO0 (2R7). These signals are complementarily pulsed whenever a function key other than DTA, FN, REG, or FLT is depressed, or whenever a hexadecimal key is depressed following FN, REG, or FLT (the occurrence of FHEXCLO).

3.8 Switch Register Loading

The Switch Register (4B1, 4D1, 4G1, 4J1, and 4M1) is loaded with a hexadecimal character with the occurrence of each SRCLK0 as mentioned previously. Data is entered into the least significant character (4B1) from the switches (HEX01:31) and left shifted through the register with each clock. The register is cleared whenever the DTA key is depressed.

3.9 Status Register

The status register is loaded in two parts as described previously. One half is loaded from FUN00:30 when a Function (FN) key is depressed by the occurrence of FTYPCLO. The least significant bit of this register is re-circulated on SGL or RUN and the second LSB is re-circulated on SSL to conform to the status codes indicated in Table 2. The second half of the register is loaded from HEX01:31 with the occurrence of FHEXCLO. These registers are initialized by SCLR0 from the Processor.

TABLE 2. STATUS CODES

KEY	DL1	DL2	DL3	DL4	DL5	DL6	DL7	DL0
SGL	1	U	X	X	X	X	X	X
INITIALIZE	U	U	U	U	U	U	O	U
RUN	0	0	0	X	X	X	X	X
WRT	0	0	1	U	U	U	U	U
RD	0	1	0	U	U	U	U	U
ADR	0	1	1	U	A ₁	A ₂	A ₃	A ₄
REG n	1	0	0	1	n ₁	n ₂	n ₃	n ₄
FLT n	1	0	1	1	n ₁	n ₂	n ₃	n ₄
FN n	1	0	0	0	n ₁	n ₂	n ₃	n ₄

A = Most significant hexadecimal digit of Switch Register

U = Unspecified

X = Unchanged

n = Hexadecimal digit associated with function (see Section 6)

The display status is presented to the Processor on the data lines (DL01:71) for the duration of time that control signal SRG0 is at a logical zero level. The data presented for status is in accordance with Table 2.

3.10 Display Register Loading

The Hexadecimal Display Panel registers and displays five bytes of data transmitted from the Processor. Two control signals are transmitted from the Processor to direct the loading of these registers. LA0 (2K5) is a low active pulse which signifies that data is available on bi-directional Data Lines D01:71 and it is to be loaded into the least significant byte of the display register. LA0 is used to initialize a four bit shift register (2M4) to 1000_2 which is used to load subsequent bytes, and generate a load pulse LA1 which is used to load the data into the LSB of the display register (2B6 and 3E6). Four subsequent LB0 pulses sent from the Processor gates data from D01:71 into successive bytes of the display register (3G6 and 3J6, 4C5 and 4E5, 4G5 and 4K5, 4N5 and 3N2). This is accomplished as each LB0 pulse is inverted and gated as LDB1, LDC1, LDD1 and LDE1 (2N4) respectively as controlled by the sequencing shift register (2M4) which is right shifted with each LB0 pulse.

3.11 Display Indicators

The two least significant bytes of the display register are gated directly to LEDs L25:40 and the hexadecimal indicators I6:9 (Sheet 3). LEDs L5:24 and hexadecimal indicators I1:5 are used to display either the most significant bytes of the display registers or the Switch Register. These sets of registers are selected through the 2:1 multiplexors (4C6, 4E6, 4H6, 4K6 and 4N6) as determined by the state of the DISSW1 (2N6). DISSW1 is high whenever the Switch Register is enabled (SRENB1) or a hexadecimal key is depressed (HKEY1).

3.12 Processor Inputs

Data is gated to the Processor in response to control signals SHI0, SLO0 or SRG0. SLO0 gates the two least significant digits of the Switch Register onto the bi-directional Data Lines D01:71 (4C3 and 4C4). SHI0 gates the next two Switch Register digits onto the bi-directional Data Lines D01:71 (4H3 and 4K3). SRG0 causes the status register bits to be gated (3D4) as per Table 2. Note that either the most significant Switch Register character is gated (4N3) if DL11 is low or the hexadecimal portion of the status register if DL11 is high (3I14).

4. PROCESSOR INTERFACING

4.1 Processor Connector

Signals from the display are terminated at a 26-080F06 type connector per the following list:

SIGNAL	PIN	SIGNAL	PIN
D01	109	LA0	203
D11	110	LB0	114
D21	111	SHI0	200
D31	112	SLO0	206
D41	202	WAIT1	102
D51	204	SRG0	113
D61	205	ESNC0	103
D71	208	ESNO0	104
POFF0	105	INIT0	101
CONT1	DB1-C1	SSGL1	106
CONT2	DB1-C2	GND	100-3
CONT3	213	GND	108
SCLR0	107	GND	212 twisted with 114
		GND	201 twisted with 203

4.2 Timing

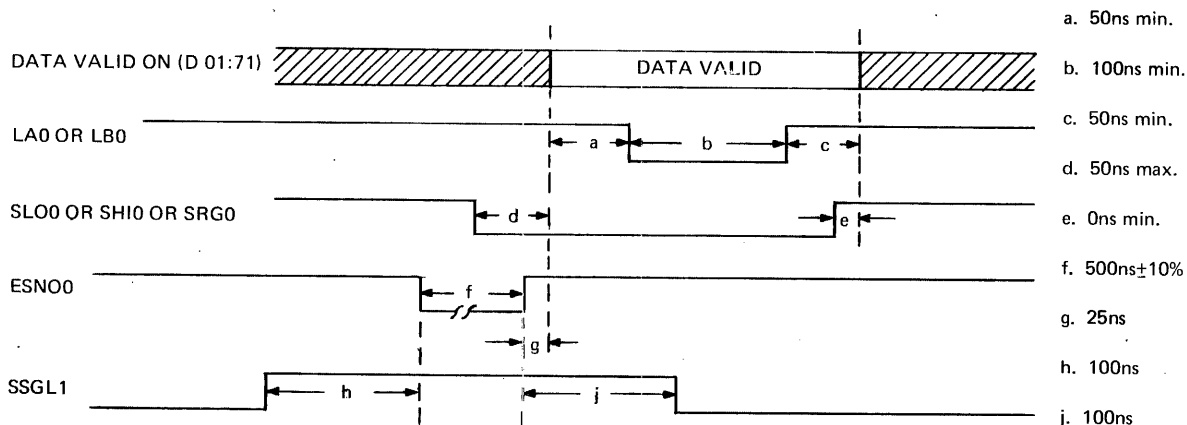

Figure 3. Hexadecimal Display Panel Timing

5. INSTALLATION PROCEDURE

The Hexadecimal Display Panel is connected to the Processor via a 17-305 cable. The 26-080F06 30-pin connector of the Hexadecimal Display Panel plugs into the mating connector as shown in Figure 4.

CNTL1, CNTL2, P5, GND, LGND, +L jumpers go to corresponding lugs on the Processor chassis display terminal strip as shown in Figure 4.

6. POWER

The Hexadecimal Display Panel draws its power from the P5 and +L lugs on the Processor chassis display terminal strip. See Figure 4.

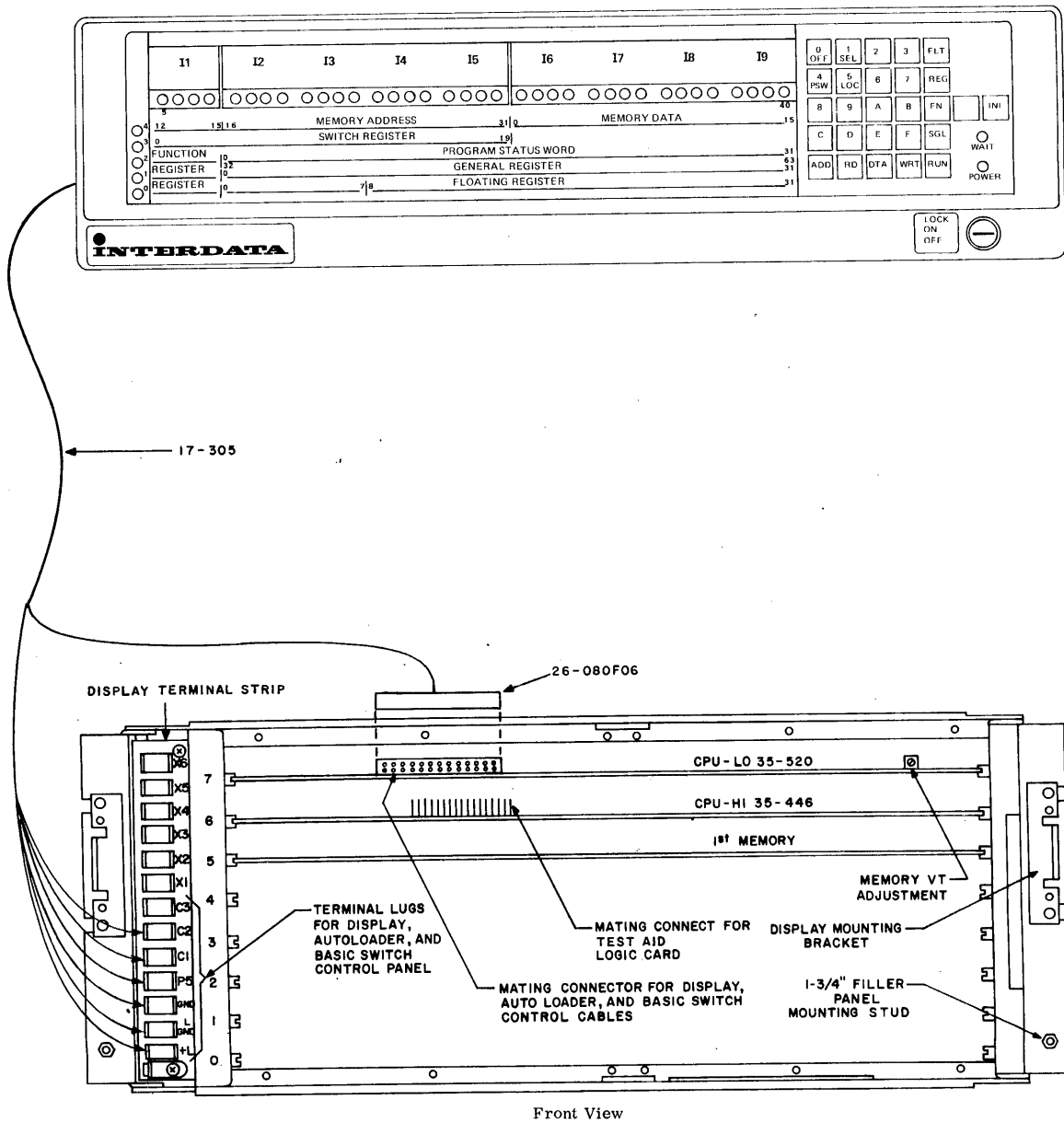

Figure 4. Typical Hexadecimal Display Installation

7. MNEMONICS

The following list provides a brief description of each mnemonic found in the Hexadecimal Display Panel. The source of each signal on Functional Schematic 09-065D08 is also provided.

<u>MNEMONIC</u>	<u>MEANING</u>	<u>SCHEMATIC LOCATION</u>
CONT1	12 VAC to turn on power supply	2L1
CONT2	12 VAC to turn off power supply	2M1
DISSW1	Controls Display Multiplexors for L5:24	2R6
ESNC0	Execute switch normally open	2R7
ESNO0	Execute switch normally closed	2R7
FTYPCL0	Function type status register clock	2N7
FHEXCL0	Hexadecimal type status register clock	2N8
FUN00:30	Encoded functional keys	Sheet 2
HEX01:31	Encoded hexadecimal keys	Sheet 2
INIT0	Initialize Processor	2H2
LA0	Low active signal from Processor which initializes the loading sequence and loads the least significant byte of the Hexadecimal Display Panel	2K5
LB0	Low active signal from Processor used to control loading of display registers by generating LDB1, LDC1, LDD1, LDE1	2L5
LDB1 } LDC1 } LDD1 }	Load display registers	2R3 2R4 2R4
LDE1	Loads display mode register and most significant hexadecimal digit of the display	2R4
POFF0	Early power OFF failure	2K1
SCLR0	System Clear, initialize status registers	3J1
SDA0	DTA key depressed	2J2
SHI0	Switch Register high half gate command	2M2
SLO0	Switch Register low half gate command	2L3
SOR0	SGL or RUN keys depressed	2K2
SRAG1	Switch Register most significant hexadecimal digit gate command	2R2
SRCLK0	Switch Register clock	2M7
SRFG1	Status Register Function high half gate command	2R2
SRG1	Status Register low half gate command	2M2
SSL1	SGL key depressed	2J6
WAIT1	Wait light control	2M6

DRAWINGS



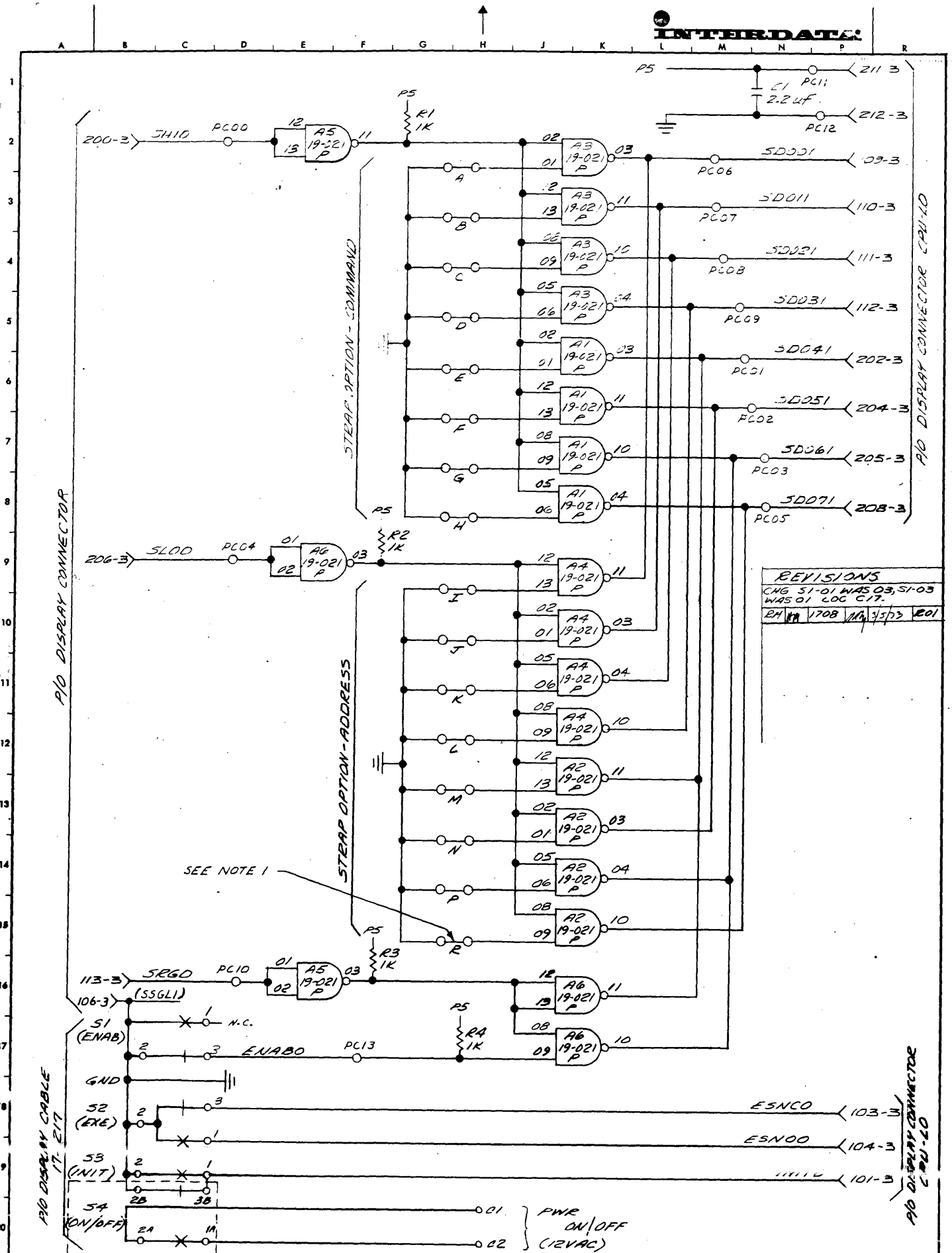

REVISIONS

CWG	51-01	WAS	03, 51-03
WAS	01	LOC	C17
EA	1708	16/3/73	201

SEE NOTE 1

NOTES 1. CIRCUIT AS SHOWN WILL GATE ADDRESS AS XFF AND COMMAND AS XFF

NAME	TITLE	DATE	TITLE
V. PERRI	DRAFT	7-18-72	FUNCTIONAL SCHEMATIC
E. GERO	CHECK	1-15-73	AUTOMATIC LOAD BD.
G. JOYCE	EMER	12-19-72	MODEL 7A
H. ROSS	O.C.	12-19-72	03018

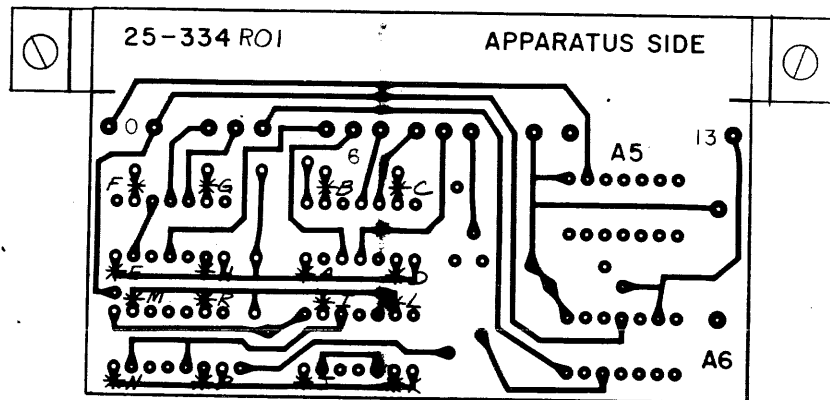

* INDICATES WHERE OPTIONAL CUTS MUST BE MADE

NAME	TITLE	DATE	TITLE
	DRAFT		
	CHK		
	ENGR		
	DIR ENG		
		TASK NO. 03018	SHEET OF 2-2
		REV. NO. 02-271 R01000	



A B C D E F G H J K L M N P R

REVISIONS

MB 1-3-73
 CHG: S2 WAS S3 & S3 WAS
 S2 LOC C4, C5.

RM	MM	1717	MM	3/9/73	EOI
----	----	------	----	--------	-----

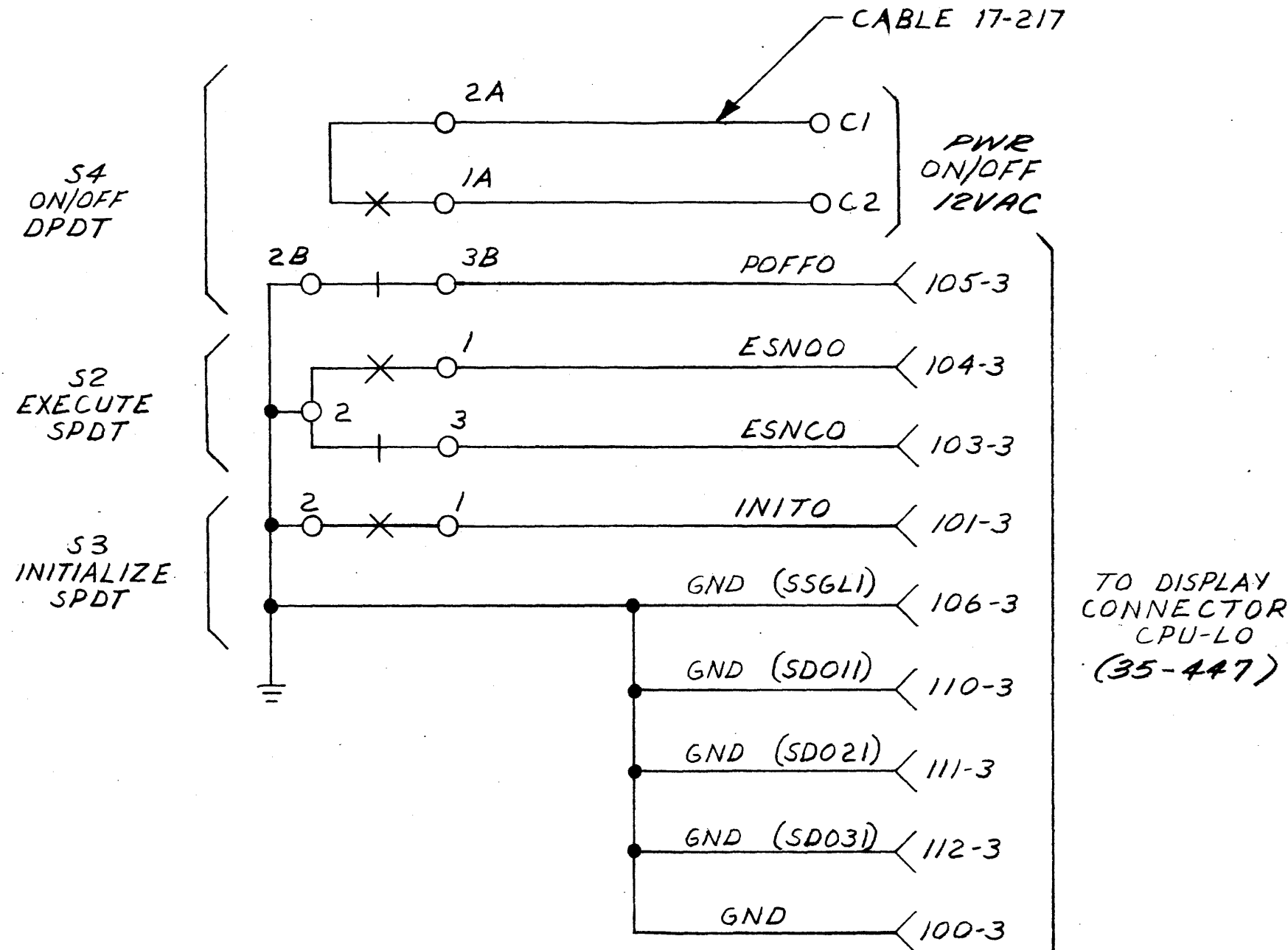

NOTES

NAME	TITLE	DATE	TITLE FUNCTIONAL SCHEMATIC
B. GRAY	DRAFT	11-13-72	MOD 74 BASIC CONTROL SWITCH
B. CERO	CHK	11-15-72	
D. FRANKENBERGER	ENG	12-19-72	
H. ROSS	QC	12-19-72	
R. E. JONES	DIR ENG	1-3-73	
			TASK NO. 03018
			DWG. NO. 02-272 EO1 BOB
			SHEET OF 1-1

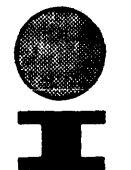

REVISIONS
 RELEASED FOR PRODUCTION
 M 12/5/74

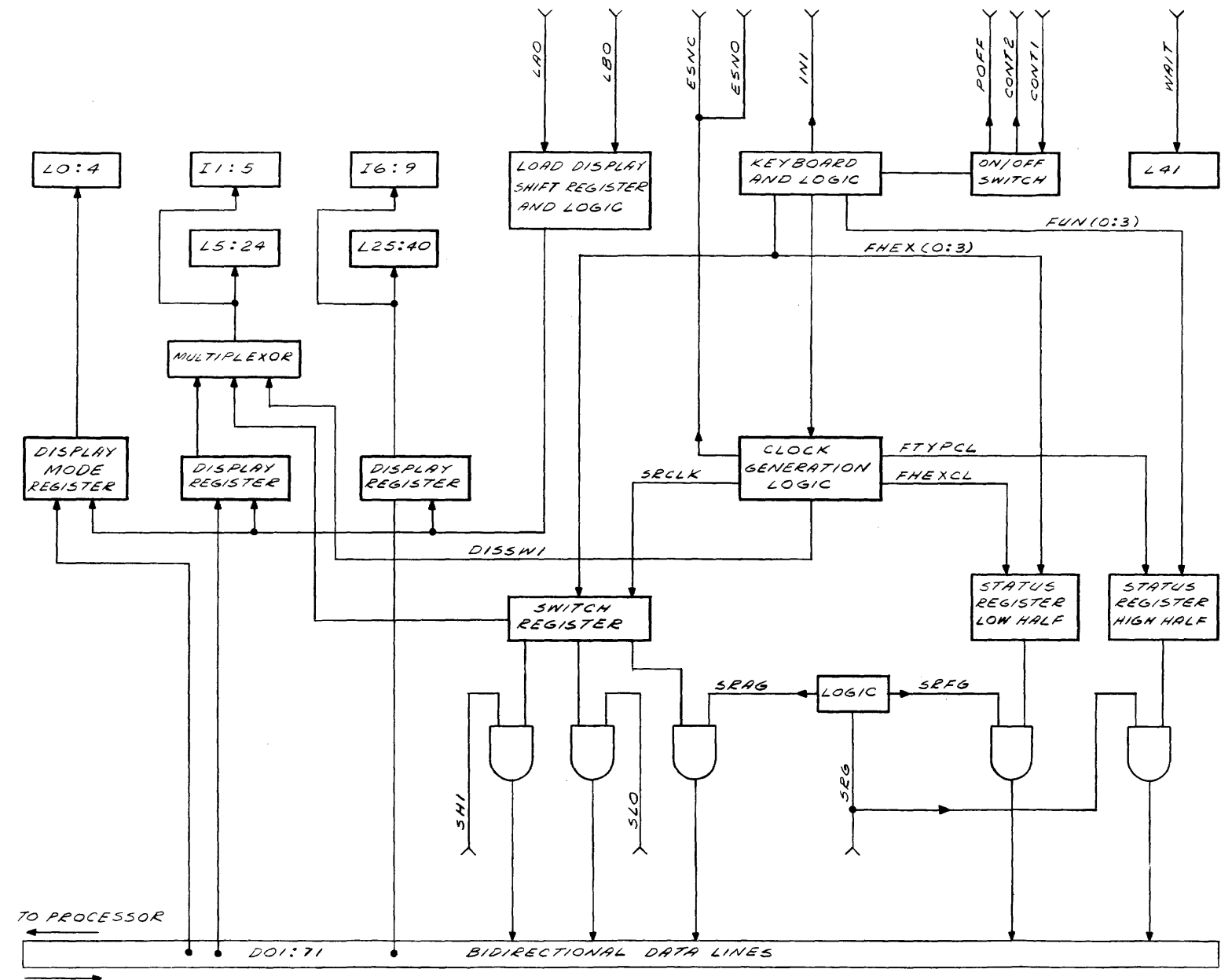

CONN-3		
TERM	ROW 1	ROW 2
00	GND	SH10
01	INIT0	GND
02	WAIT1	D41
03	ESNCO	L90
04	ESNOO	D51
05	POFF0	D61
06	SSGL1	SLOO
07	SCLRO	
08	GND	D71
09	D01	
10	D11	
11	D21	
12	D31	GND
13	SRG0	CONT3
14	L80	

BLOCK DIAGRAM

REVISION LEVEL OF THIS SHEET IS CONSIDERED THE REVISION LEVEL OF THE DOCUMENT

SHEET	REV			
INDEX	SHT	2	3	4

BRUNING 41 231 16042

NOTES

NAME	TITLE	DATE	TITLE
H. MATTER	DRAFT	1-28-74	FUNCTIONAL SCHEMATIC
H. MATTER	CHK	1-28-74	HEXADECIMAL DISPLAY
S. ALSSINA	ENGR	1-31-74	
L. JOHANN	TEST	1-31-74	

SHEET OF 1-4



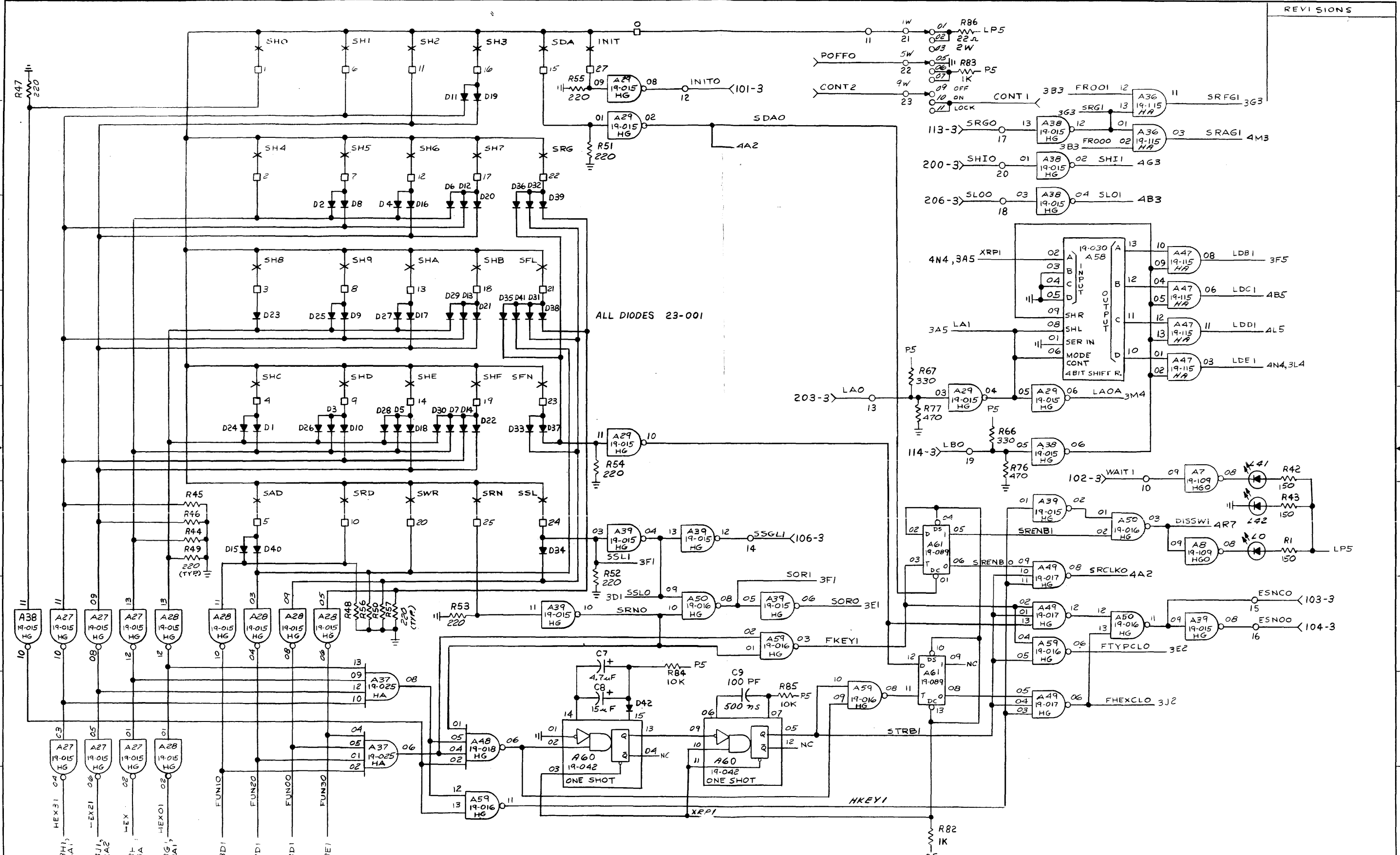

ALL DIODES 23-001

NOTES
1. L0 THRU L42 ARE 33-027

NAME	TITLE	DATE	TITLE FUNCTIONAL SCHEMATIC
P. EDWARDS	DRAFT	12-5-73	HEXADECIMAL DISPLAY
	ENGR		
	DIR ENG		

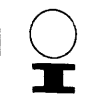

BRUNING 44231 16042

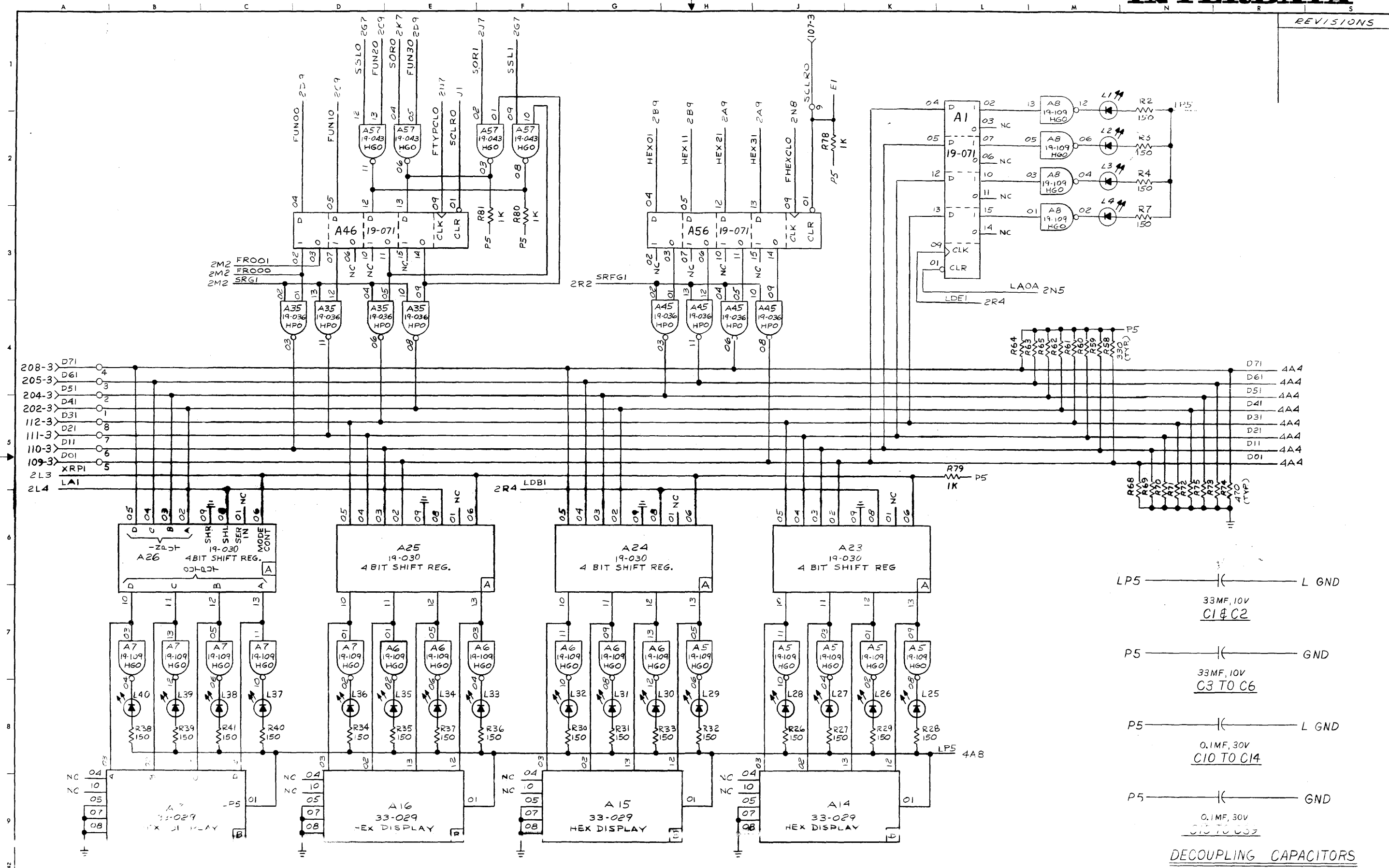

- LP5 ———— L GND
33MF, 10V
C1 & C2
- P5 ———— GND
33MF, 10V
C3 TO C6
- P5 ———— L GND
0.1MF, 30V
C10 TO C14
- P5 ———— GND
0.1MF, 30V
C15 TO C32

DECOUPLING CAPACITORS

NOTES

NAME	TITLE	DATE	TITLE FUNCTIONAL SCHEMATIC
F. EDWARDS	DRAFT	2-2-73	HEXADECIMAL DISPLAY
	CHK		
	ENGR		

BRUNING 44 231 16042

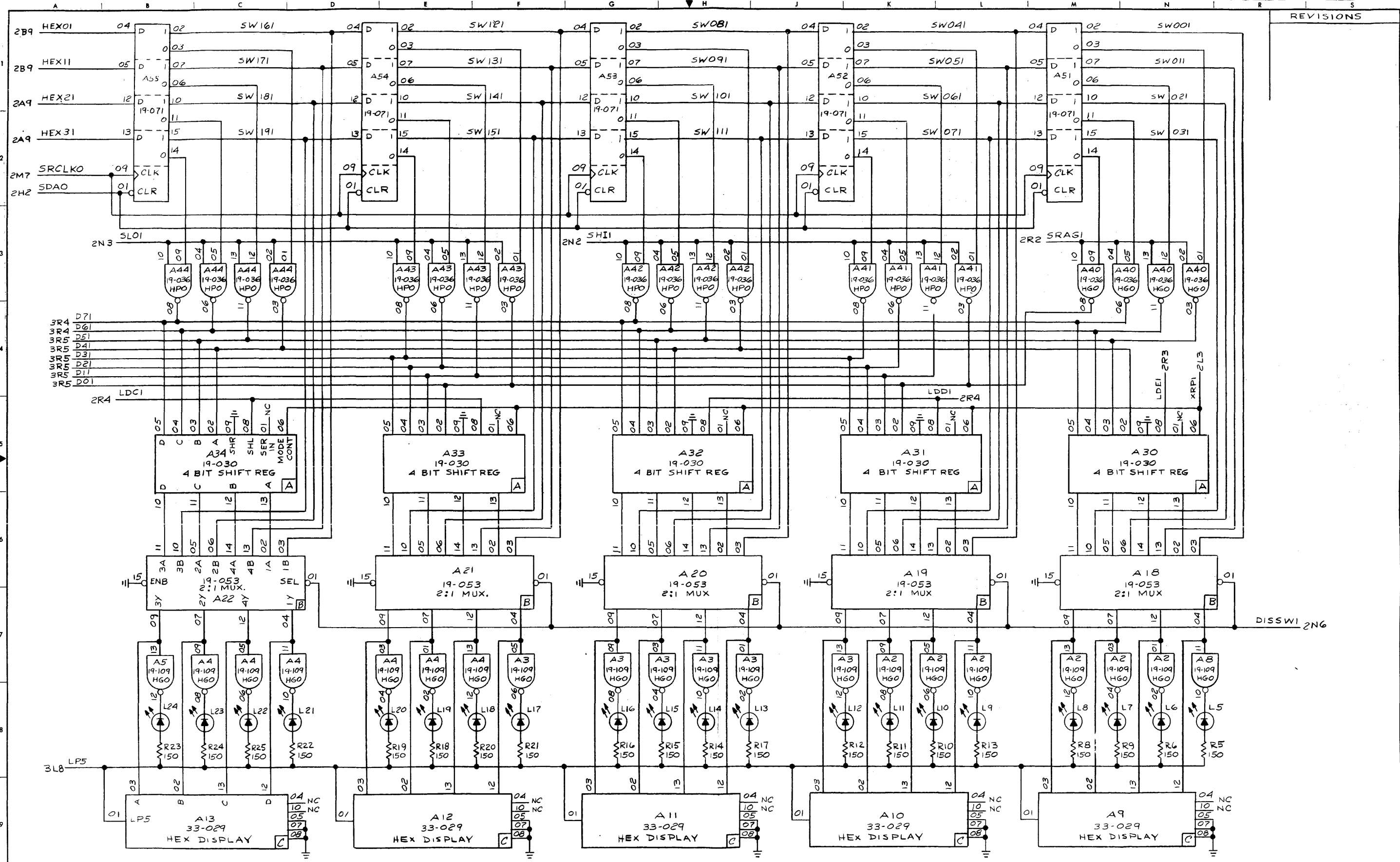

REVISIONS

BRUNING 44.231.16042

NOTES

NAME	TITLE	DATE	TITLE FUNCTIONAL SCHEMATIC
P EDWARDS	DRAFT	2-3-73	HEXADECIMAL DISPLAY
	CHK		
	ENGR		
	DIR ENG		



4-4

REVISIONS	
PRE PRODUCTION APPROVAL	INIT DATE
WP/CI 3030-001	6-27-73 R01
REVISED CIRCUITRY	
WP/CI 3030-001	7-18-73 R02
RELEASED FOR PRODUCTION	
MFG. ENG. 10-23-73 R03	
R11 & R12 WERE 5.1K	
R66 WAS 1/2 W. (R2)	
R11 & R12 WERE 2.4K	
ADDED C36 & GND SYMBOL	
ADDED LEADS TO TBI-8, 9.	
ADDED (3) STRAP OPTION JUMPER'S	
WP/CI 2026	11-17-79 R05

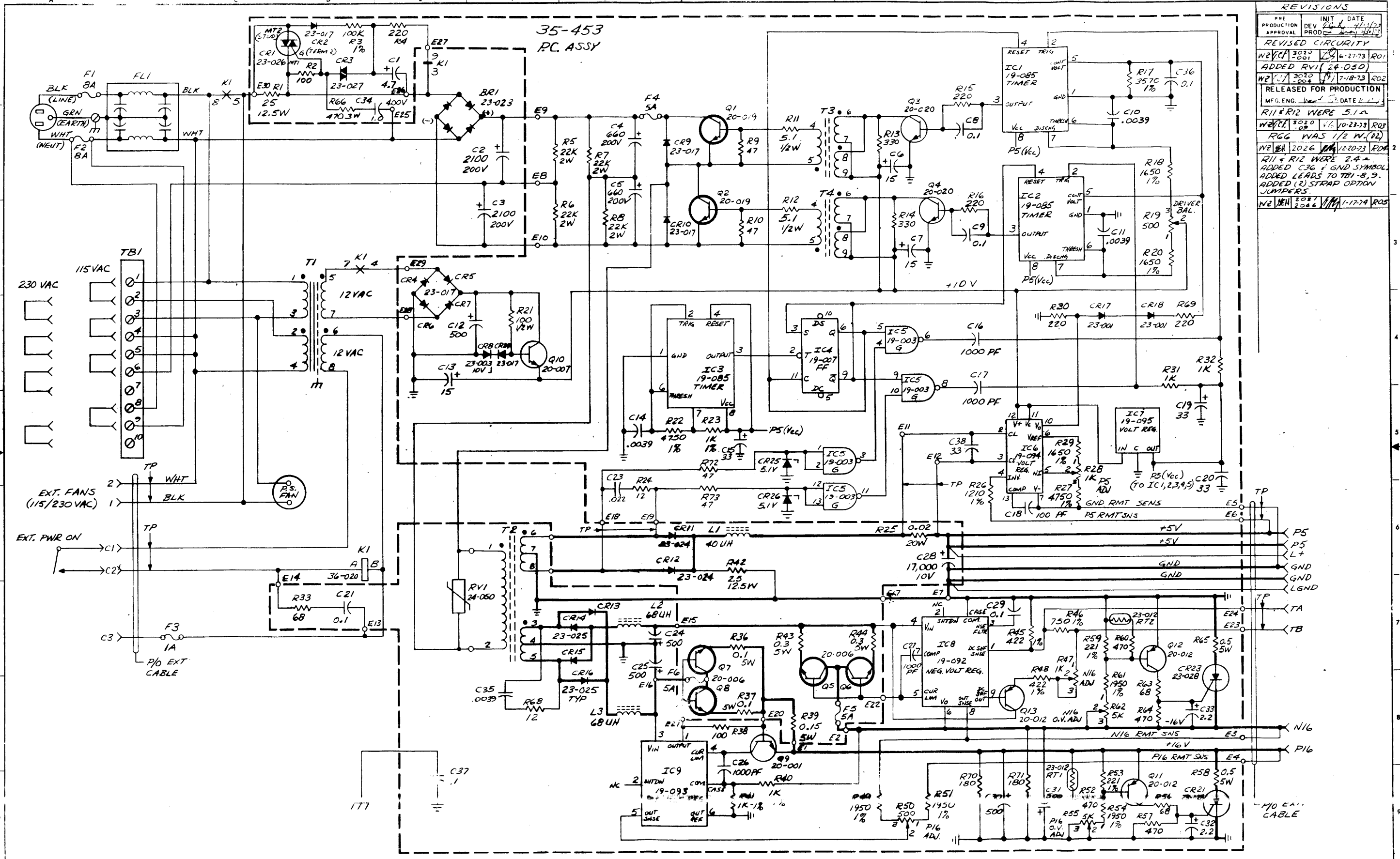

NOTES 1. UNLESS OTHERWISE SPECIFIED, RESISTOR VALUES ARE IN OHMS-1/4W; CAPACITOR VALUES ARE IN MICROFARADS.

R73 T4	NAME	TITLE	DATE	TITLE
C38 R72	J.F. FLEMING	SWITCHING REGULATED	10-25-72	POWER SUPPLY
R26 RV1	W. ZILGER		1-26-73	
Q13	T. LAUGSEN, JR.		3/9/73	
FG				
L3				

BRUNING 44 231 1604Z

REVISIONS

NO.	DATE	BY	DESCRIPTION
1	12-14-73	RUY	ADDED R82 RESISTOR
2	12-14-73	RUY	ADDED C36 + GND SYMBOL
3	12-14-73	RUY	ADDED LEADS TO T81-8, 9
4	12-14-73	RUY	ADDED (2) STRAP OPTION JUMPERS
5	1-17-74	R03	

35-510
P.C. ASSY

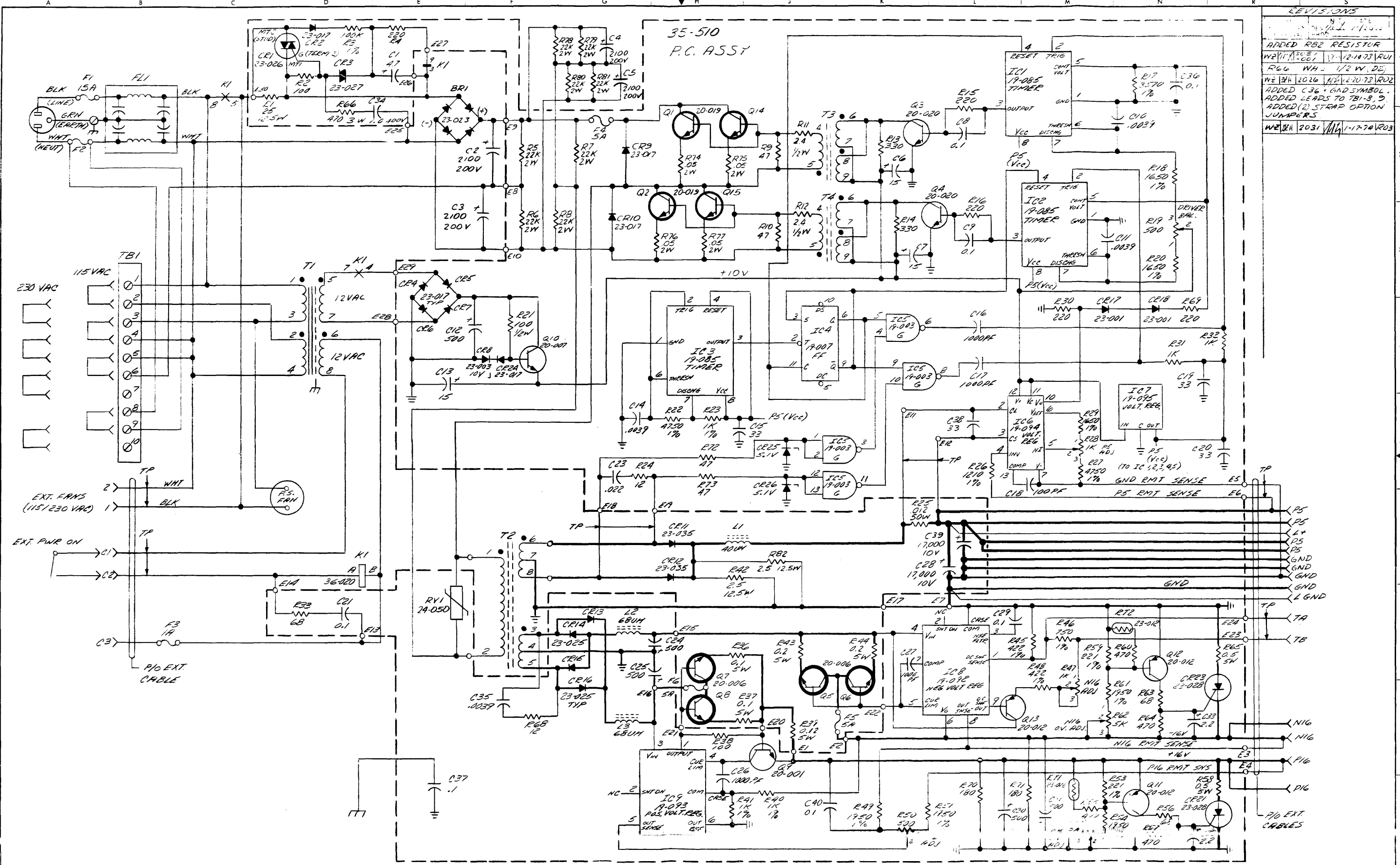

NOTES 1. UNLESS OTHERWISE SPECIFIED,
RESISTOR VALUES ARE IN OHMS, 1/4W,
CAPACITOR VALUES ARE IN MICRO-
FARADS

NAME	TITLE	DATE	TITLE
E82 TA	SWITCHING REGULATED POWER SUPPLY	12-14-73	SCHEMATIC
L40 ETC			
CR26 RV1			
Q15			
F6			
L3			

BRUNING 44-231-16042



INTERDATA

RELEASED FOR PRODUCTION
 MFG. ENG. DATE 2-20-74
 REVISED TO REFLECT
 ROE COPPER
 FOR THE USE OF THE
 CHANGES. SEE PART 101
 FOR LED'S DIO NOT USE FLAT SIDE
 3M 2074 1/1 10 M RO1

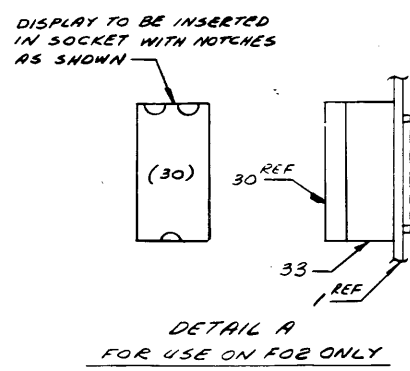
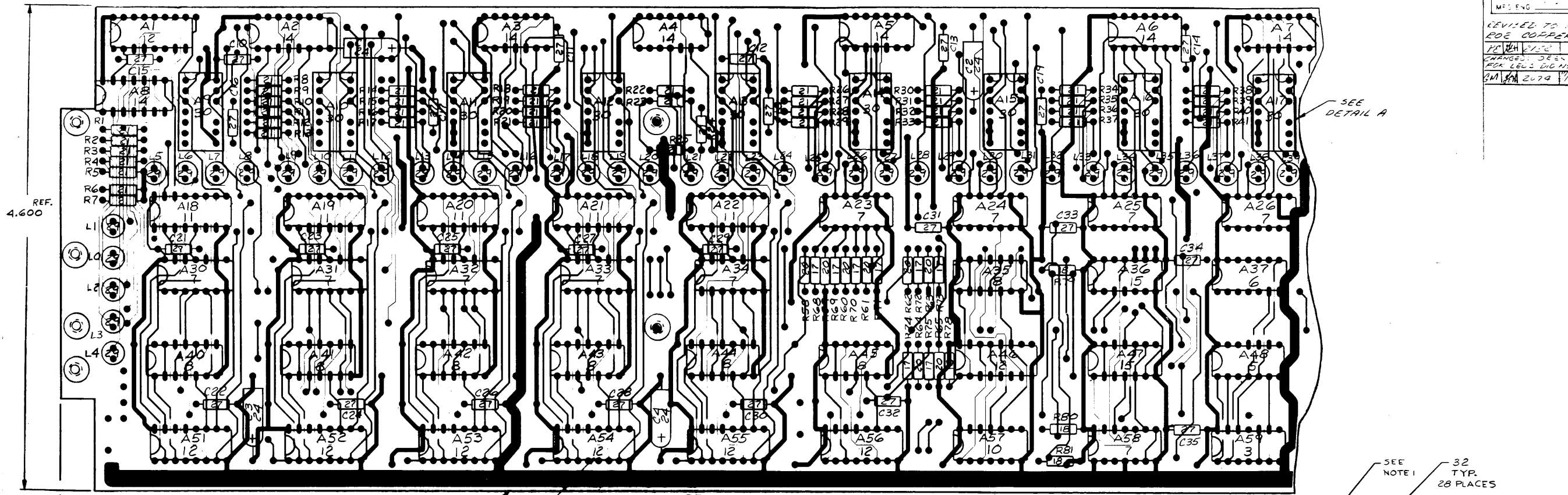

F02	AS SHOWN
F01	LESS ITEMS 30 & 33
MIRRATION INFORMATION	

CLOSED DOT OR
 FLAT SIDE OF LED
 INDICATES CATHODE
 END. (TYPICAL)

BASE OF LED'S MUST BE
 PARALLEL TO P.C. BOARD TO
 ACHIEVE PERPENDICULARITY
 BEFORE & DURING FLOW
 SOLDER.

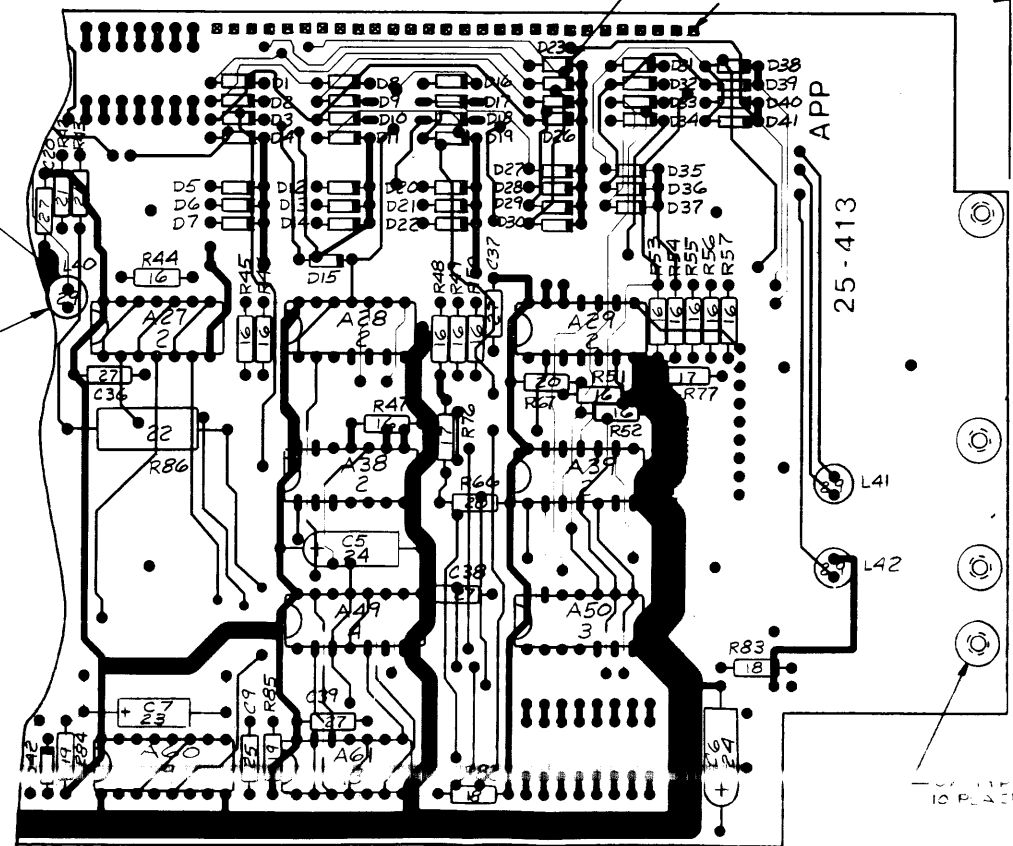

DESIGNED BY	DATE	ASSEMBLY PRT. CRT.
PEDWARDS	1-16-74	HEXIDECIMAL
H. MATTER	19 FEB 74	DISPLAY
S. MESSINA	2-15-74	
S. MESSINA		35-51962 D03

UNLOCATED COMPONENTS ARE ITEM 28.

REVISIONS

REVISED SHEET 12
 12/17/73 VA 831-73 R01
 REVISED SH7, 1, 6, 9, 17, 20, 24
 126, 35-446 F 35-447 WERE R01
 B. J. 12/20/73 VA 112-13-73 R02
 ADDED SCLRC0 PINS TO
 CONN 3 PIN INDEX TABLE.
 ADDED 35-446 F01 35-446
 F02 35-446 F03 TO SUPPLE-
 MENTARY INFO TABLE.
 REVISED TITLE BLOCK
 SNITS 1 THRU 26
 12/23/73 VA 112-13-73 R03
 REVISE SH7 1A IN
 REV LEVEL TABLE
 REV LEVEL OF 35-446
 R04 WAS R03.
 12/23/73 VA 112-13-73 R04
 REVISE SNITS 1, 3 & 12
 IN REV LEVEL TABLE
 REVISION LEVEL OF
 35-446 R05, 35-446
 F01 R02 & 35-446
 F02 R02 WERE SPEC'D
 AS R04, R00 & R00
 RESP.
 12/29/73 VA 112-13-73 R05
 REVISED SNITS 7, 14, 15
 IN REV LEVEL TABLE
 REV LEVEL OF 35-446
 WAS R05, 35-446 F01 WAS
 R05, 35-446 F02 WAS R02
 ADDED IN SUPP INFO 35-520M01
 12/29/73 VA 112-13-73 R06
 12/29/73 VA 112-13-73 R07

MNEM.	SCHEMATIC LOCATION		TYPE
	CPU-HI	CPU-LO	
ACKO	10E9-SOURCE		I/O
ADDO	6M6-SOURCE	20H8-INPUT	INT.
ADRSO	10E9-SOURCE	26A5-INPUT	I/O
ANQDI	8N1-INPUT	21D9-SOURCE	INT.
ANDO	6R6-SOURCE	20K1-INPUT	INT.
ATNO	9E7-INPUT		I/O
B000	1666-SOURCE	22E1-INPUT	INT.
B010	1666-SOURCE	22C1-INPUT	INT.
B020	1666-SOURCE	22C1-INPUT	INT.
B030	1666-SOURCE	22D1-INPUT	INT.
B040	1666-SOURCE	22E1-INPUT	INT.
B050	1664-SOURCE	22F1-INPUT	INT.
B060	1664-SOURCE	22G1-INPUT	INT.
B070	1663-SOURCE	22H1-INPUT	INT.
B080	5N3-SOURCE	22J1-INPUT	INT.
B090	5N4-SOURCE	22K1-INPUT	INT.
B100	5N5-SOURCE	22L1-INPUT	INT.
B110	5N6-SOURCE	22M1-INPUT	INT.
B120	5N6-SOURCE	22N1-INPUT	INT.
B130	5N7-SOURCE	22O1-INPUT	INT.
B140	5N8-SOURCE	22P1-INPUT	INT.
B150	5N7-SOURCE	22S1-INPUT	INT.
BCLKO	14H8-SOURCE		EXT. TEST
CGNDO	12N2-SOURCE	21C1-INPUT	INT.
CL070	10D9-SOURCE		I/O
CLB1	12N2-SOURCE	21C1-INPUT	INT.
CLMD10	14M9-SOURCE	17E5-INPUT	INT.
CLVDO	7K4-SOURCE	21A3-INPUT	INT.
CMPO	10F9-SOURCE	26A4-INPUT	I/O
CMND1	7K2-SOURCE	20M1-INPUT	INT.
D000	11M1-SOURCE	INPUT	I/O
D010	11M2-SOURCE	INPUT	I/O
D020	11M3-SOURCE	INPUT	I/O
D030	11M4-SOURCE	INPUT	I/O
D040	11M5-SOURCE	INPUT	I/O
D050	11M6-SOURCE	INPUT	I/O
D060	11M7-SOURCE	INPUT	I/O
D070	11M8-SOURCE	INPUT	I/O
D080	11M9-SOURCE	INPUT	I/O
D090	11M2-SOURCE	INPUT	I/O
D100	11M3-SOURCE	INPUT	I/O
D110	11M4-SOURCE	INPUT	I/O
D120	11M5-SOURCE	INPUT	I/O
D130	11M6-SOURCE	INPUT	I/O
D140	11M7-SOURCE	INPUT	I/O
D150	11M8-SOURCE	INPUT	I/O
D160	10E9-SOURCE	26A5-INPUT	I/O
D170	10D9-SOURCE	26A4-INPUT	I/O
DSTORD	12N8-SOURCE	21D1-INPUT	INT.
END	14L6-SOURCE		MEM.
ENH1	18A1-INPUT	20B8-SOURCE	INT.
ENMS1	18A7-SOURCE	19C3-INPUT	INT.
ENSCO		26C2-INPUT	EXT. DIS.
ERO	16N2-SOURCE		MEM.
ESN00		26C1-INPUT	EXT. DIS.
FCRTN1	9E7-INPUT	26M1-SOURCE	INT.
FLR121	8G1-INPUT	21N7-SOURCE	INT.
FLR131	8G1-INPUT	21K7-SOURCE	INT.
FLR141	8G1-INPUT	21N7-SOURCE	INT.
FLR151	8G1-INPUT	21S7-SOURCE	INT.
FSRSD	14H6-SOURCE	16N2-INPUT	INT.
FSNGL1	9E7-INPUT	26H2-SOURCE	INT.
FTT10	13B2-INPUT		EXT. DIS.
FWR10	7K5-SOURCE	26H3-INPUT	INT.

MNEM.	SCHEMATIC LOCATION		TYPE
	CPU-HI	CPU-LO	
GCC81	6F6-SOURCE	21R9-INPUT	INT.
GCRY0	10L5-SOURCE	21F1-INPUT	INT.
GRMS0	6F6-SOURCE	22E1-INPUT	INT.
HPRR00	17F3-SOURCE	17E3-INPUT	INT.
NWO	10G9-INPUT		I/O
IMM0	6G6-SOURCE	20E1-INPUT	INT.
IMM1	6M6-SOURCE	24M1-INPUT	INT.
INNO	15N6-SOURCE		MEM.
IN370		12B7-INPUT	EXT. DIS.
IRAND1	13G4-SOURCE	21A4-INPUT	INT.
LRO		26M9-SOURCE	EXT. DIS.
LAR0	6L6-SOURCE	23L1-INPUT	INT.
LBO		26M9-SOURCE	EXT. DIS.
LCO		26M9-SOURCE	EXT. DIS.
LCC0	10K5-SOURCE	20D8-INPUT	INT.
LDO		26M9-SOURCE	INT.
LDFAR0	9E9-SOURCE	21S7-INPUT	INT.
LDI01	11M9-SOURCE	11M9-INPUT	INT.
LIRNO	9L1-INPUT	21E9-SOURCE	INT.
LMAR0	16J1-SOURCE		INT.
LMAS0	14K8-SOURCE	16J6-INPUT	INT.
LMAR1	14K4-SOURCE	16M1-INPUT	INT.
LAPD0	7K7-SOURCE	20E1-INPUT	INT.
LRO	15N3-SOURCE		MEM.
MR000	16R9-SOURCE		MEM.
MR001	16R9-SOURCE		MEM.
MR010	16R9-SOURCE		MEM.
MR011	16D9-SOURCE		MEM.
MR020	16D9-SOURCE		MEM.
MR021	16D9-SOURCE		MEM.
MR030	16E9-SOURCE		MEM.
MR040	16E9-SOURCE		MEM.
MR050	16E9-SOURCE		MEM.
MR060	16G9-SOURCE		MEM.
MR070	16G9-SOURCE		MEM.
MR080	16H9-SOURCE		MEM.
MR090	16H9-SOURCE		MEM.
MR100	16J9-SOURCE		MEM.
MR110	16K9-SOURCE		MEM.
MR120	16L9-SOURCE		MEM.
MR130	16M9-SOURCE		MEM.
MR140	16N9-SOURCE		MEM.
MR150	16N9-SOURCE		MEM.
MR160	16P9-SOURCE		MEM.
MR170	16Q9-SOURCE		MEM.
MR180	16R9-SOURCE		MEM.
MR190	16R9-SOURCE		MEM.
MR200	16S9-SOURCE		MEM.
MR210	16T9-SOURCE		MEM.
MR220	16U9-SOURCE		MEM.
MR230	16V9-SOURCE		MEM.
MR240	16W9-SOURCE		MEM.
MR250	16X9-SOURCE		MEM.
MR260	16Y9-SOURCE		MEM.
MR270	16Z9-SOURCE		MEM.
MR280	17A9-SOURCE		MEM.
MR290	17B9-SOURCE		MEM.
MR300	17C9-SOURCE		MEM.
MR310	17D9-SOURCE		MEM.
MR320	17E9-SOURCE		MEM.
MR330	17F9-SOURCE		MEM.
MR340	17G9-SOURCE		MEM.
MR350	17H9-SOURCE		MEM.
MR360	17I9-SOURCE		MEM.
MR370	17J9-SOURCE		MEM.
MR380	17K9-SOURCE		MEM.
MR390	17L9-SOURCE		MEM.
MR400	17M9-SOURCE		MEM.
MR410	17N9-SOURCE		MEM.
MR420	17O9-SOURCE		MEM.
MR430	17P9-SOURCE		MEM.
MR440	17Q9-SOURCE		MEM.
MR450	17R9-SOURCE		MEM.
MR460	17S9-SOURCE		MEM.
MR470	17T9-SOURCE		MEM.
MR480	17U9-SOURCE		MEM.
MR490	17V9-SOURCE		MEM.
MR500	17W9-SOURCE		MEM.
MR510	17X9-SOURCE		MEM.
MR520	17Y9-SOURCE		MEM.
MR530	17Z9-SOURCE		MEM.
MR540	18A9-SOURCE		MEM.
MR550	18B9-SOURCE		MEM.
MR560	18C9-SOURCE		MEM.
MR570	18D9-SOURCE		MEM.
MR580	18E9-SOURCE		MEM.
MR590	18F9-SOURCE		MEM.
MR600	18G9-SOURCE		MEM.
MR610	18H9-SOURCE		MEM.
MR620	18I9-SOURCE		MEM.
MR630	18J9-SOURCE		MEM.
MR640	18K9-SOURCE		MEM.
MR650	18L9-SOURCE		MEM.
MR660	18M9-SOURCE		MEM.
MR670	18N9-SOURCE		MEM.
MR680	18O9-SOURCE		MEM.
MR690	18P9-SOURCE		MEM.
MR700	18Q9-SOURCE		MEM.
MR710	18R9-SOURCE		MEM.
MR720	18S9-SOURCE		MEM.
MR730	18T9-SOURCE		MEM.
MR740	18U9-SOURCE		MEM.
MR750	18V9-SOURCE		MEM.
MR760	18W9-SOURCE		MEM.
MR770	18X9-SOURCE		MEM.
MR780	18Y9-SOURCE		MEM.
MR790	18Z9-SOURCE		MEM.
MR800	19A9-SOURCE		MEM.
MR810	19B9-SOURCE		MEM.
MR820	19C9-SOURCE		MEM.
MR830	19D9-SOURCE		MEM.
MR840	19E9-SOURCE		MEM.
MR850	19F9-SOURCE		MEM.
MR860	19G9-SOURCE		MEM.
MR870	19H9-SOURCE		MEM.
MR880	19I9-SOURCE		MEM.
MR890	19J9-SOURCE		MEM.
MR900	19K9-SOURCE		MEM.
MR910	19L9-SOURCE		MEM.
MR920	19M9-SOURCE		MEM.
MR930	19N9-SOURCE		MEM.
MR940	19O9-SOURCE		MEM.
MR950	19P9-SOURCE		MEM.
MR960	19Q9-SOURCE		MEM.
MR970	19R9-SOURCE		MEM.
MR980	19S9-SOURCE		MEM.
MR990	19T9-SOURCE		MEM.
MR1000	19U9-SOURCE		MEM.
MR1001	19U9-SOURCE		MEM.
MR1002	19U9-SOURCE		MEM.
MR1003	19U9-SOURCE		MEM.
MR1004	19U9-SOURCE		MEM.
MR1005	19U9-SOURCE		MEM.
MR1006	19U9-SOURCE		MEM.
MR1007	19U9-SOURCE		MEM.
MR1008	19U9-SOURCE		MEM.
MR1009	19U9-SOURCE		MEM.
MR1010	19U9-SOURCE		MEM.
MR1011	19U9-SOURCE		MEM.
MR1012	19U9-SOURCE		MEM.
MR1013	19U9-SOURCE		MEM.
MR1014	19U9-SOURCE		MEM.
MR1015	19U9-SOURCE		MEM.
MR1016	19U9-SOURCE		MEM.
MR1017	19U9-SOURCE		MEM.
MR1018	19U9-SOURCE		MEM.
MR1019	19U9-SOURCE		MEM.
MR1020	19U9-SOURCE		MEM.
MR1021	19U9-SOURCE		MEM.
MR1022	19U9-SOURCE		MEM.
MR1023	19U9-SOURCE		MEM.
MR1024	19U9-SOURCE		MEM.
MR1025	19U9-SOURCE		MEM.
MR1026	19U9-SOURCE		MEM.
MR1027	19U9-SOURCE		MEM.
MR1028	19U9-SOURCE		MEM.
MR1029	19U9-SOURCE		MEM.
MR1030	19U9-SOURCE		MEM.
MR1031	19U9-SOURCE		MEM.
MR1032	19U9-SOURCE		MEM.
MR1033	19U9-SOURCE		MEM.
MR1034	19U9-SOURCE		MEM.
MR1035	19U9-SOURCE		MEM.
MR1036	19U9-SOURCE		MEM.
MR1037	19U9-SOURCE		MEM.
MR1038	19U9-SOURCE		MEM.
MR1039	19U9-SOURCE		MEM.
MR1040	19U9-SOURCE		MEM.
MR1041	19U9-SOURCE		MEM.
MR1042	19U9-SOURCE		MEM.
MR1043	19U9-SOURCE		MEM.
MR1044	19U9-SOURCE		MEM.
MR1045	19U9-SOURCE		MEM.
MR1046	19U9-SOURCE		MEM.
MR1047	19U9-SOURCE		MEM.
MR1048	19U9-SOURCE		MEM.
MR1049	19U9-SOURCE		MEM.
MR1050	19U9-SOURCE		MEM.
MR1051	19U9-SOURCE		MEM.
MR1052	19U9-SOURCE		MEM.
MR1053	19U9-SOURCE		MEM.
MR1054	19U9-SOURCE		MEM.
MR1055	19U9-SOURCE		MEM.
MR1056	19U9-SOURCE		MEM.
MR1057	19U9-SOURCE		MEM.
MR1058	19U9-SOURCE		MEM.
MR1059	19U9-SOURCE		MEM.
MR1060	19U9-SOURCE		MEM.
MR1061	19U9-SOURCE		MEM.
MR1062	19U9-SOURCE		MEM.
MR1063	19U9-SOURCE		MEM.
MR1064	19U9-SOURCE		MEM.
MR1065	19U9-SOURCE		MEM.
MR1066	19U9-SOURCE		MEM.
MR1067	19U9-SOURCE		MEM.
MR1068	19U9-SOURCE		MEM.
MR1069	19U9-SOURCE		MEM.
MR1070	19U9-SOURCE		MEM.
MR1071	19U9-SOURCE		MEM.
MR1072	19U9-SOURCE		MEM.
MR1073	19U9-SOURCE		MEM.
MR1074	19U9-SOURCE		MEM.
MR1075	19U9-SOURCE		MEM.
MR1076	19U9-SOURCE		MEM.
MR1077	19U9-SOURCE		MEM.
MR1078	19U9-SOURCE		MEM.
MR1079	19U9-SOURCE		MEM.
MR1080	19U9-SOURCE		MEM.
MR1081	19U9-SOURCE		MEM.
MR1082	19U9-SOURCE		MEM.
MR1083	19U9-SOURCE		MEM.
MR1084	19U9-SOURCE		MEM.
MR1085	19U9-SOURCE		MEM.
MR1086	19U9-SOURCE		MEM.
MR1087	19U9-SOURCE		MEM.
MR1088	19U9-SOURCE		MEM.
MR1089	19U9-SOURCE		MEM.
MR1090	19U9-SOURCE		MEM.
MR1091	19U9-SOURCE		MEM.
MR1092	19U9-SOURCE		MEM.
MR1093	19U9-SOURCE		MEM.
MR1094	19U9-SOURCE		MEM.
MR1095	19U9-SOURCE		MEM.
MR1096	19U9-SOURCE		MEM.
MR1097	19U9-SOURCE		MEM.
MR1098	19U9-SOURCE		MEM.
MR1099	19U9-SOURCE		MEM.
MR1100	19U9-SOURCE		MEM.
MR1101	19U9-SOURCE		MEM.
MR1102	19U9-SOURCE		MEM.
MR1103	19U9-SOURCE		MEM.
MR1104	19U9-SOURCE		MEM.
MR1105	19U9-SOURCE		MEM.
MR1106	19U9-SOURCE		MEM.
MR1107	19U9-SOURCE		MEM.
MR1108	19U9-SOURCE		MEM.
MR1109	19U9-SOURCE		MEM.
MR1110	19U9-SOURCE		MEM.
MR1111	19U9-SOURCE		MEM.
MR1112	19U9-SOURCE		MEM.
MR1113	19U9-SOURCE		MEM.
MR1114	19U9-SOURCE		MEM.
MR1115	19U9-SOURCE		MEM.
MR1116	19U9-SOURCE		MEM.
MR1117	19U9-SOURCE		MEM.
MR1118	19U9-SOURCE		MEM.
MR1119	19U9-SOURCE</		

BACK PANEL MAP

FILE NO.	CPU0		CPU1		MEM/IO		CON.	FILE NO.	CON.	MEM/IO		FILE NO.
	ROW	ROW	ROW	ROW	ROW	ROW				ROW	ROW	
41	P5	P5	P5	P5	P5	GND		41				41
40	GND	GND	GND	GND	GND	GND		40				40
39	RD09A	UM50	RD09A	UM50	P15	P15		39				39
38	RD10A	GCCB1	RD10A	GCCB1	N15	N15		38				38
37	RD11A	RM50	RD11A	RM50	MD150	MD160		37				37
36	RD12A	RD13A	RD12A	RD13A	MD130	MD140		36				36
35	S31	AR00	S31	AR00	MD110	MD120		35				35
34	IMM1	AM01	IMM1	AM01	MD090	MD100		34				34
33	MD150	MD160	MD150	MD160	MD070	MD080		33				33
32	MD140	MD110	MD140	MD110	MD050	MD060		32				32
31	MD130	MD100	MD130	MD100	MD030	MD040		31				31
30	MD120	MD090	MD120	MD090	MD010	MD020		30				30
29	MD110	MD080	MD110	MD080	MD000	EXVT		29				29
28	YDESTO	SCL0A	YDESTO	SCL0A	YDPI	TEMPA		28				28
27	YDPI	AND0	YDPI	AND0	WRTO	TEMPB		27				27
26	YD50	YD50	YD50	YD50	YPMI	SCL00		26				26
25	YD50	YD50	YD50	YD50	EXMBO	HWO		25				25
24	IMM0	LR00	IMM0	LR00	EXDUO	SYNO		24				24
23	RD121	RD130	RD121	RD130	EXDUO	ATNO		23				23
22	RD131	RD140	RD131	RD140	RD190	RACKO		22				22
21	RD141	RD150	RD141	RD150	RACKO	TACKO		21				21
20	RD151	RD160	RD151	RD160	RD170	TACKO		20				20
19	RD161	RD170	RD161	RD170	RD180	DR0		19				19
18	RD171	RD180	RD171	RD180	RD190	DR0		18				18
17	RD181	RD190	RD181	RD190	DR0	DR0		17				17
16	RD191	RD200	RD191	RD200	DR0	DR0		16				16
15	RD201	RD210	RD201	RD210	DR0	DR0		15				15
14	RD211	RD220	RD211	RD220	DR0	DR0		14				14
13	RD221	RD230	RD221	RD230	DR0	DR0		13				13
12	RD231	RD240	RD231	RD240	DR0	DR0		12				12
11	RD241	RD250	RD241	RD250	DR0	DR0		11				11
10	RD251	RD260	RD251	RD260	DR0	DR0		10				10
09	RD261	RD270	RD261	RD270	DR0	DR0		09				09
08	RD271	RD280	RD271	RD280	DR0	DR0		08				08
07	RD281	RD290	RD281	RD290	DR0	DR0		07				07
06	RD291	RD300	RD291	RD300	DR0	DR0		06				06
05	RD301	RD310	RD301	RD310	DR0	DR0		05				05
04	RD311	RD320	RD311	RD320	DR0	DR0		04				04
03	RD321	RD330	RD321	RD330	DR0	DR0		03				03
02	RD331	RD340	RD331	RD340	DR0	DR0		02				02
01	RD341	RD350	RD341	RD350	DR0	DR0		01				01
00	RD351	RD360	RD351	RD360	DR0	DR0		00				00

FILE NO. 001
 FILE NO. 002
 FILE NO. 003
 FILE NO. 004
 FILE NO. 005
 FILE NO. 006
 FILE NO. 007
 FILE NO. 008
 FILE NO. 009
 FILE NO. 010
 FILE NO. 011
 FILE NO. 012
 FILE NO. 013
 FILE NO. 014
 FILE NO. 015
 FILE NO. 016
 FILE NO. 017
 FILE NO. 018
 FILE NO. 019
 FILE NO. 020
 FILE NO. 021
 FILE NO. 022
 FILE NO. 023
 FILE NO. 024
 FILE NO. 025
 FILE NO. 026
 FILE NO. 027
 FILE NO. 028
 FILE NO. 029
 FILE NO. 030
 FILE NO. 031
 FILE NO. 032
 FILE NO. 033
 FILE NO. 034
 FILE NO. 035
 FILE NO. 036
 FILE NO. 037
 FILE NO. 038
 FILE NO. 039
 FILE NO. 040
 FILE NO. 041
 FILE NO. 042
 FILE NO. 043
 FILE NO. 044
 FILE NO. 045
 FILE NO. 046
 FILE NO. 047
 FILE NO. 048
 FILE NO. 049
 FILE NO. 050
 FILE NO. 051
 FILE NO. 052
 FILE NO. 053
 FILE NO. 054
 FILE NO. 055
 FILE NO. 056
 FILE NO. 057
 FILE NO. 058
 FILE NO. 059
 FILE NO. 060
 FILE NO. 061
 FILE NO. 062
 FILE NO. 063
 FILE NO. 064
 FILE NO. 065
 FILE NO. 066
 FILE NO. 067
 FILE NO. 068
 FILE NO. 069
 FILE NO. 070
 FILE NO. 071
 FILE NO. 072
 FILE NO. 073
 FILE NO. 074
 FILE NO. 075
 FILE NO. 076
 FILE NO. 077
 FILE NO. 078
 FILE NO. 079
 FILE NO. 080
 FILE NO. 081
 FILE NO. 082
 FILE NO. 083
 FILE NO. 084
 FILE NO. 085
 FILE NO. 086
 FILE NO. 087
 FILE NO. 088
 FILE NO. 089
 FILE NO. 090
 FILE NO. 091
 FILE NO. 092
 FILE NO. 093
 FILE NO. 094
 FILE NO. 095
 FILE NO. 096
 FILE NO. 097
 FILE NO. 098
 FILE NO. 099
 FILE NO. 100

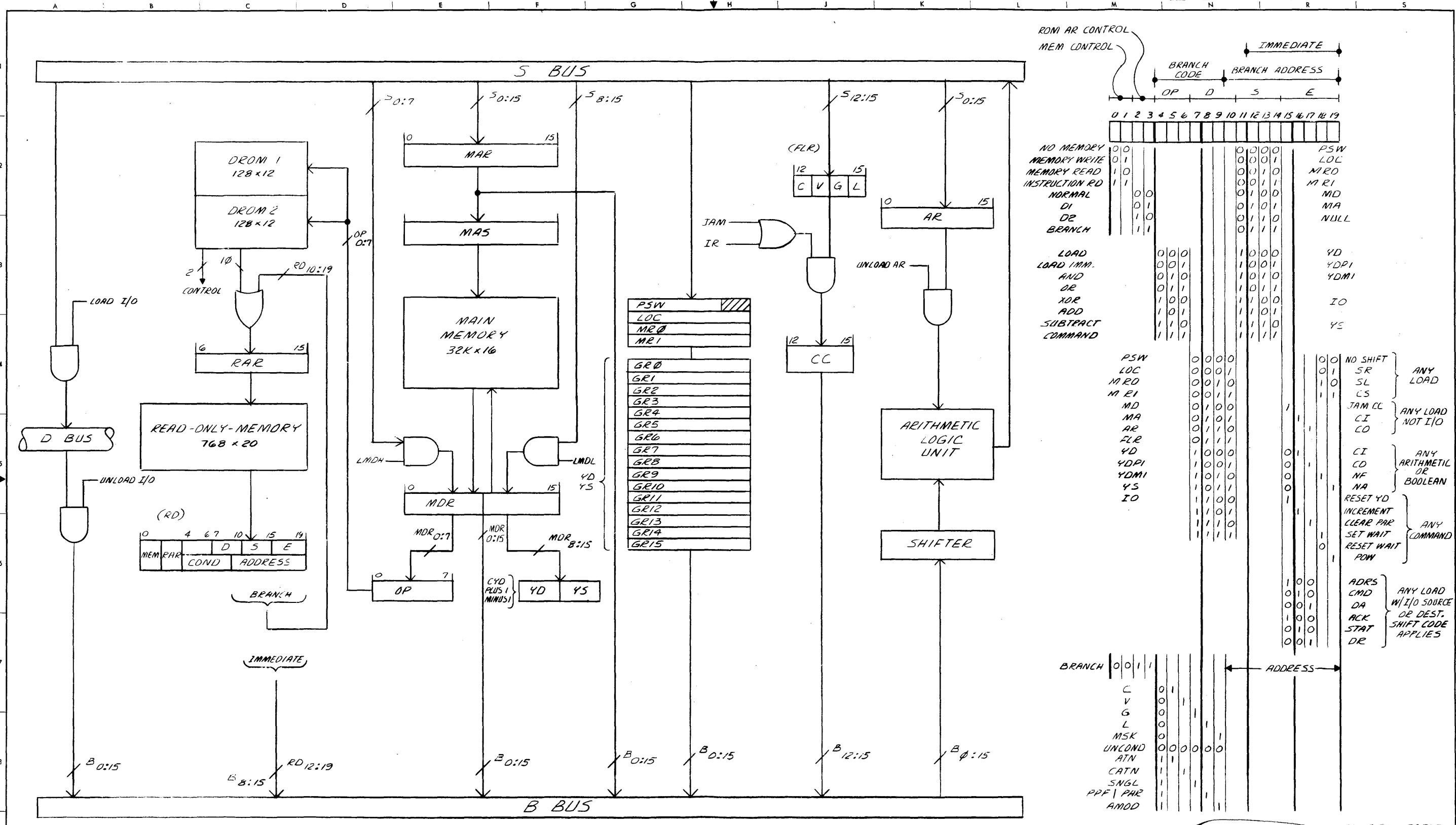

ROM AR CONTROL MEM CONTROL

OP	D	S	E	IMMEDIATE
0	1	2	3	4-19
NO MEMORY	0	0	0	PSW
MEMORY WRITE	0	1	0	LDC
MEMORY READ	1	0	0	MRO
INSTRUCTION RD	1	1	0	MRI
NORMAL	0	0	0	MD
DI	0	1	0	MA
DZ	1	0	0	NULL
BRANCH	1	1	0	
LOAD	0	0	0	YD
LOAD IMM.	1	0	0	YDPI
AND	0	1	0	YDMI
OR	0	1	1	
XOR	1	0	0	
ADD	1	0	1	IO
SUBTRACT	1	1	0	YS
COMMAND	1	1	1	

PSW	LDC	MRO	MRI	MD	MA	AR	FLR	YD	YDPI	YDMI	IO	YS
0	0	0	0	0	0	0	0	0	0	0	0	0
1	0	0	0	1	0	0	0	0	0	0	0	0
0	1	0	0	0	0	0	0	0	0	0	0	0
0	0	1	0	0	0	0	0	0	0	0	0	0
0	0	0	1	0	0	0	0	0	0	0	0	0
0	0	0	0	1	0	0	0	0	0	0	0	0
0	0	0	0	0	1	0	0	0	0	0	0	0
0	0	0	0	0	0	1	0	0	0	0	0	0
0	0	0	0	0	0	0	1	0	0	0	0	0
0	0	0	0	0	0	0	0	1	0	0	0	0
0	0	0	0	0	0	0	0	0	1	0	0	0
0	0	0	0	0	0	0	0	0	0	1	0	0
0	0	0	0	0	0	0	0	0	0	0	1	0
0	0	0	0	0	0	0	0	0	0	0	0	1

BRANCH

MEM PAR	COND	ADDRESS
0	4	6 7 10 15 19

IMMEDIATE

MEM PAR	COND	ADDRESS
0	4	6 7 10 15 19

BRANCH ADDRESS

BRANCH	ADDRESS
0	0
1	1
0	0
1	1
0	0
1	1
0	0
1	1
0	0
1	1
0	0
1	1
0	0
1	1
0	0
1	1
0	0
1	1
0	0
1	1

DROM FORMAT

VECTOR ADDRESS
4 5 6 7 8 9 10 11 12 13 14 15

BLOCK DIAGRAM & MICRO INSTRUCTION FORMAT

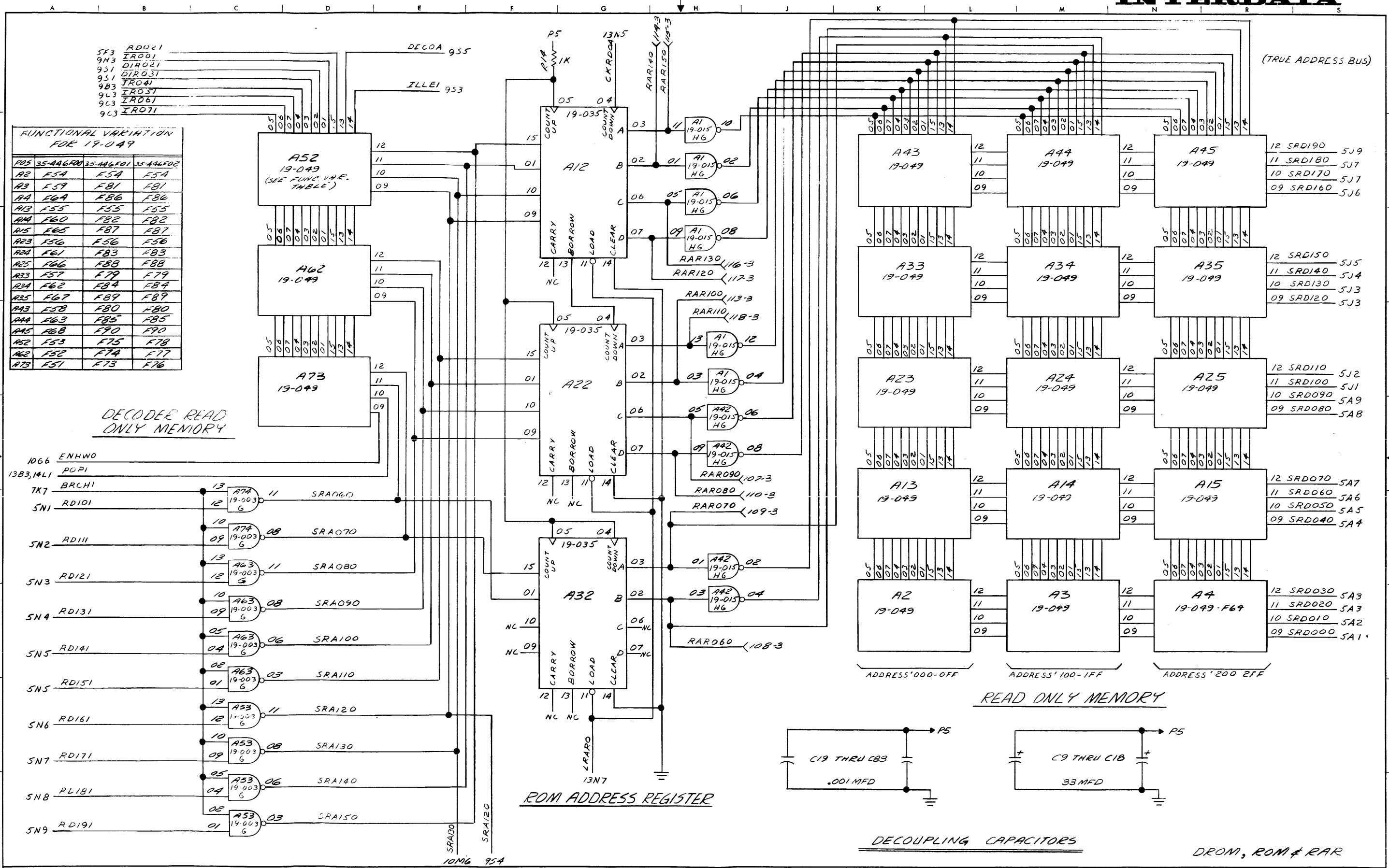

FUNCTIONAL VARIATION FOR 19-049

F05	35-446F00	35-446F01	35-446F02
A2	F54	F54	F54
A3	F59	F81	F81
A4	F6A	F86	F86
A13	F55	F55	F55
A14	F60	F82	F82
A15	F65	F87	F87
A23	F56	F56	F56
A24	F61	F83	F83
A25	F66	F88	F88
A33	F57	F79	F79
A34	F62	F84	F84
A35	F67	F89	F89
A43	F58	F80	F80
A44	F63	F85	F85
A45	F68	F90	F90
A52	F53	F75	F78
A53	F52	F74	F77
A73	F51	F73	F76

DECODED READ ONLY MEMORY

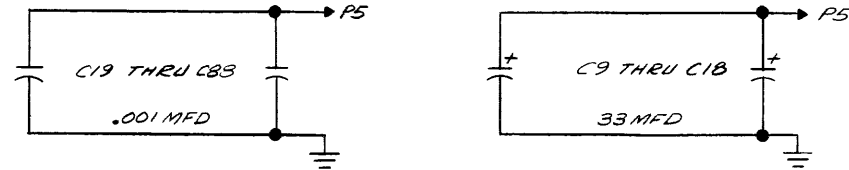
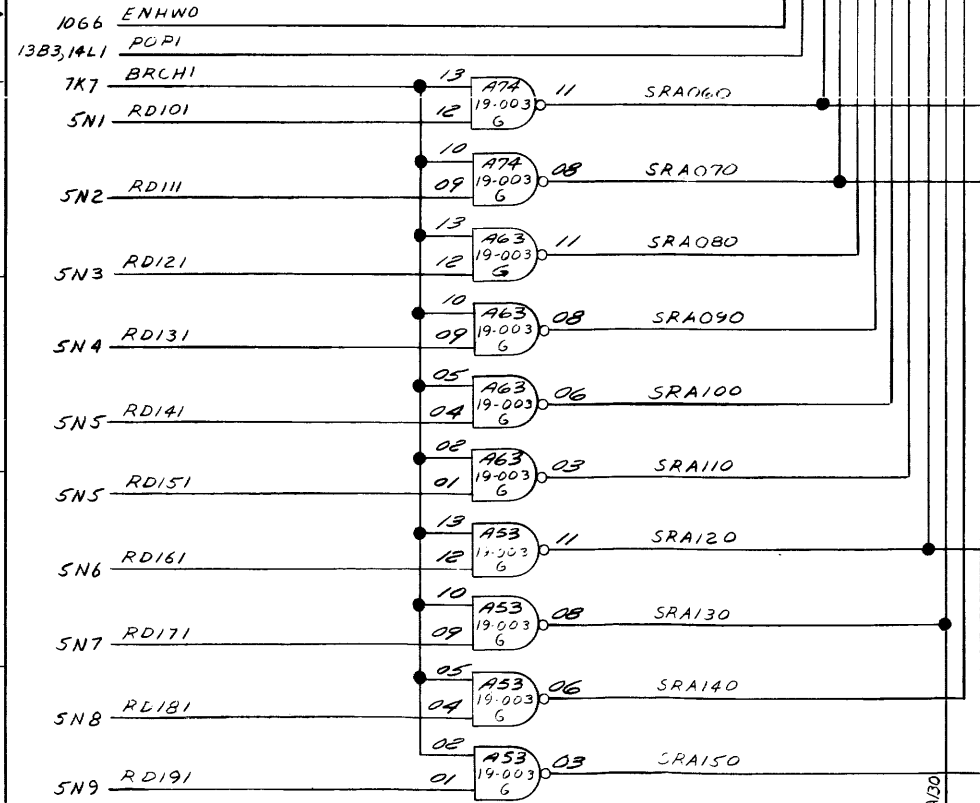

DROM, ROM & RAR

NOTES
ALL APPARATUS THIS SHEET LOCATED ON CPUHI BOARD 35-446F00, 35-446F01, AND 35-446F02 UNLESS OTHERWISE SPECIFIED.

REVISIONS		NAME	TITLE	DATE	TITLE
1	DELETED FUNC. VARI. FROM 19-049 & ADDED FUNC. VARI. TABLE REVISED TITLE BLOCK	B. GRAY	DRAFT	11-4-72	FUNCTIONAL SCHEMATIC
2			CHK		PROCESSOR
3			ENGR		
TASK NO. 0301B		DIR ENG		SHEET OF 4-26	
DATE 12-17-73		NO. 01-058E01 D08			

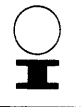

REVISIONS	
REVISED TITLE BLOCK	DATE
P2 10/2033	11/19/73
1001	

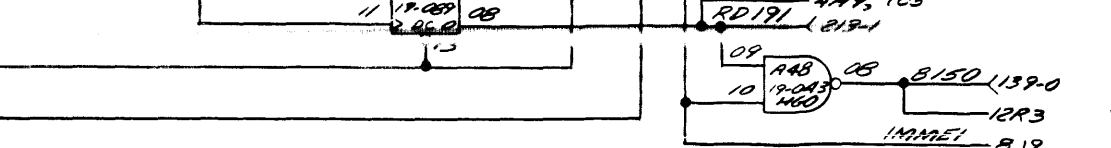
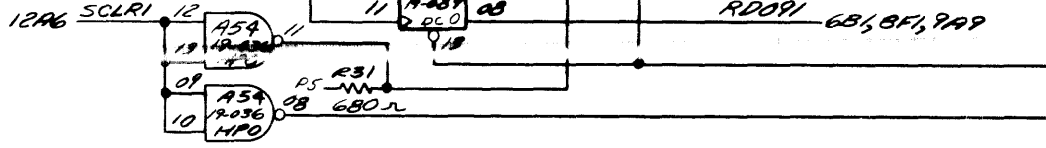
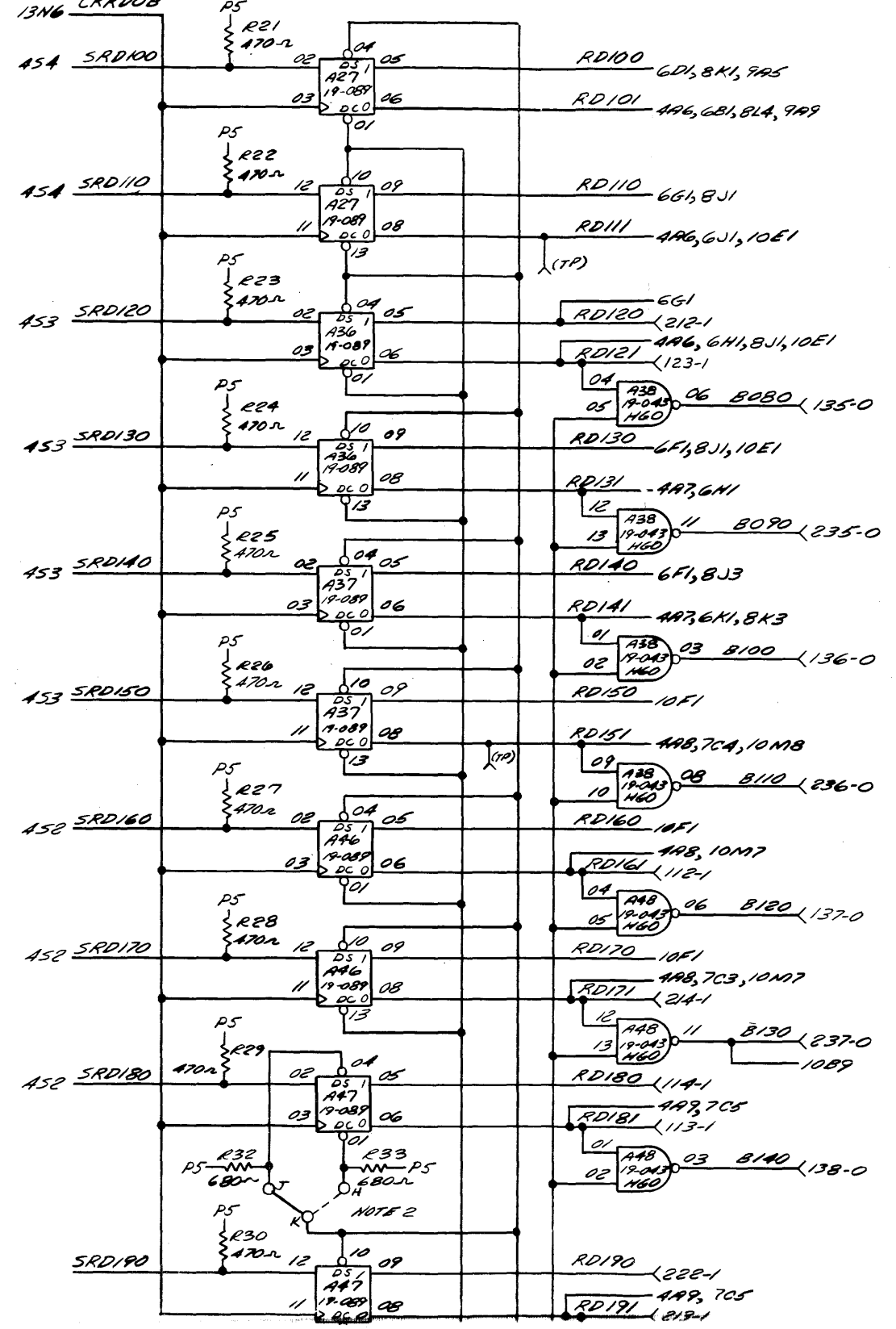
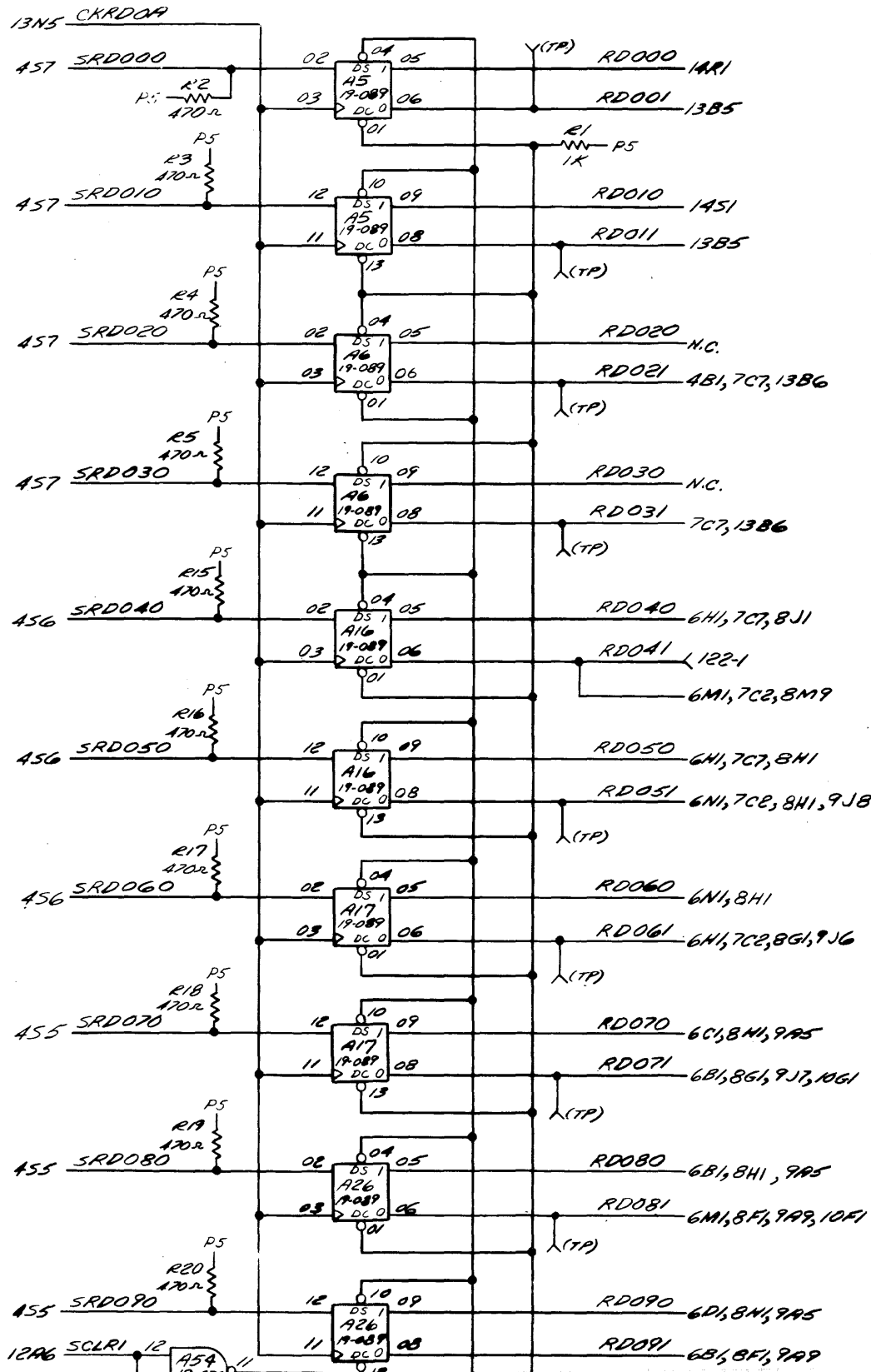

ROM DATA REGISTER
IMMEDI 8J9

NOTES
1. ALL APPROPRIATE THIS SHEET - LOCATED ON CPU BOARD 35-446F00, 35-446F01 AND 35-446F02 UNLESS OTHERWISE SPECIFIED.
2. RD INITIALIZED TO X'30100, NORMAL POWER UP; OR X'30102, AUTO RESTART.

NAME	TITLE	DATE	TITLE
REDWARDS	DRAFT		FUNCTIONAL SCHEMATIC
	CHK		PROCESSOR
	ENGR		03018
	DIR ENG		01-058E01 D08



REVISIONS

A18 WAS 19-015 (4 PLACES)	
B.G. GRAY	1900
REVISION TITLE BLOCK	
P2	2033

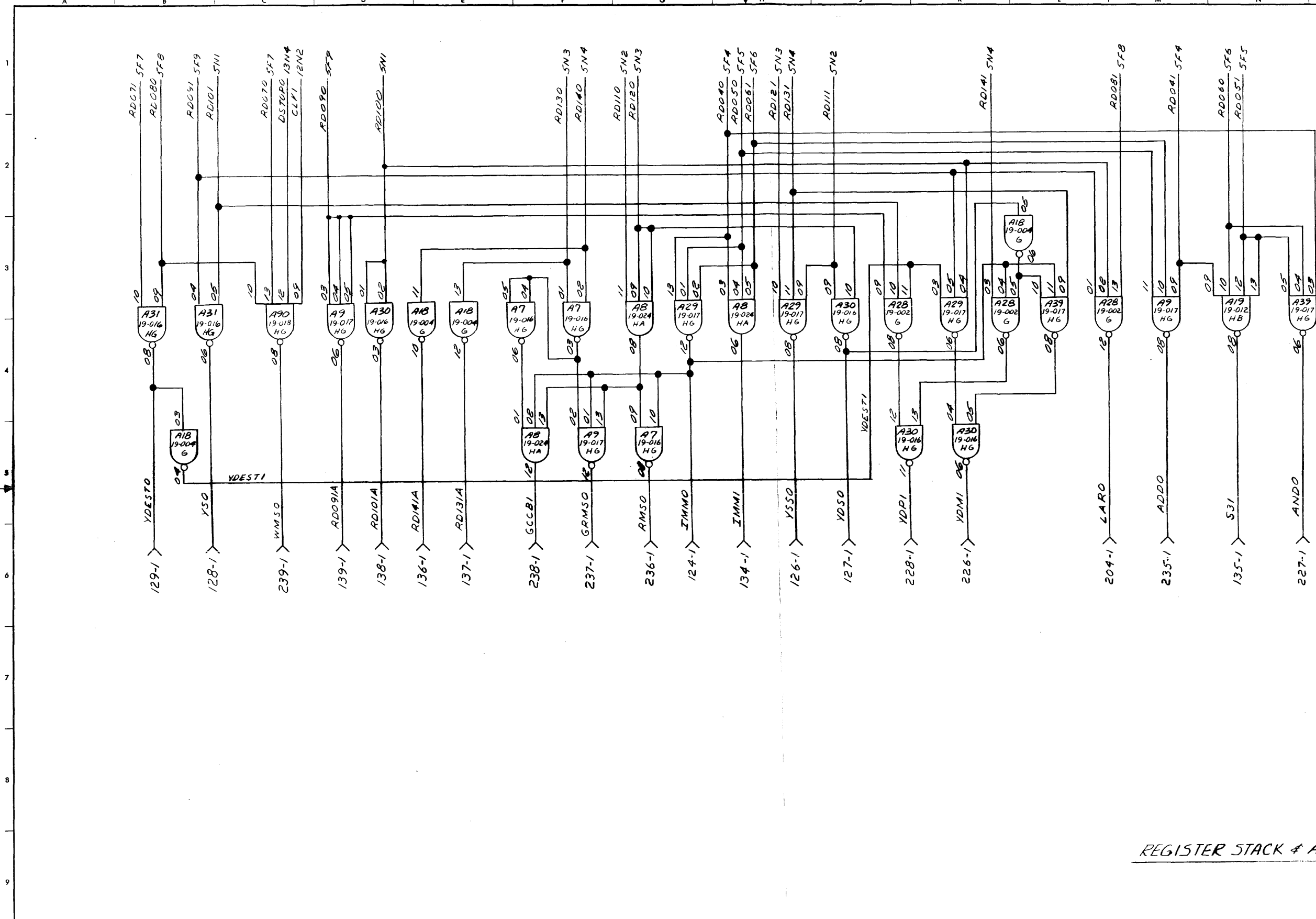

REGISTER STACK & ALU DECODERS

NOTES
 1. ALL APPARATUS THIS SHEET LOCATED ON
 CPUHI BOARD 35-446F00, 35-446F01 AND
 35-446F02 UNLESS OTHERWISE SPECIFIED.

NAME	TITLE	DATE	TITLE
B. GRAY	DRAFT	11-4-72	FUNCTIONAL SCHEMATIC
	CHK		PROCESSOR
	ENGR		
	DIR ENG		
TASK NO.	SHEET OF		
03018	6-26		
DOC NO.			
01-05BRO2D08			

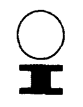

BRUNING 44-231 16042

REVISIONS			
AREA EA, ADDED 19-044 (FRSW020)			
12-9-78	ISS		
REVISED TITLE BLOCK			
2-11-73	213-73	201	
AREA NB: A87 WAS 19-043 HGO			
2-11-74	2145	4-3-74	202

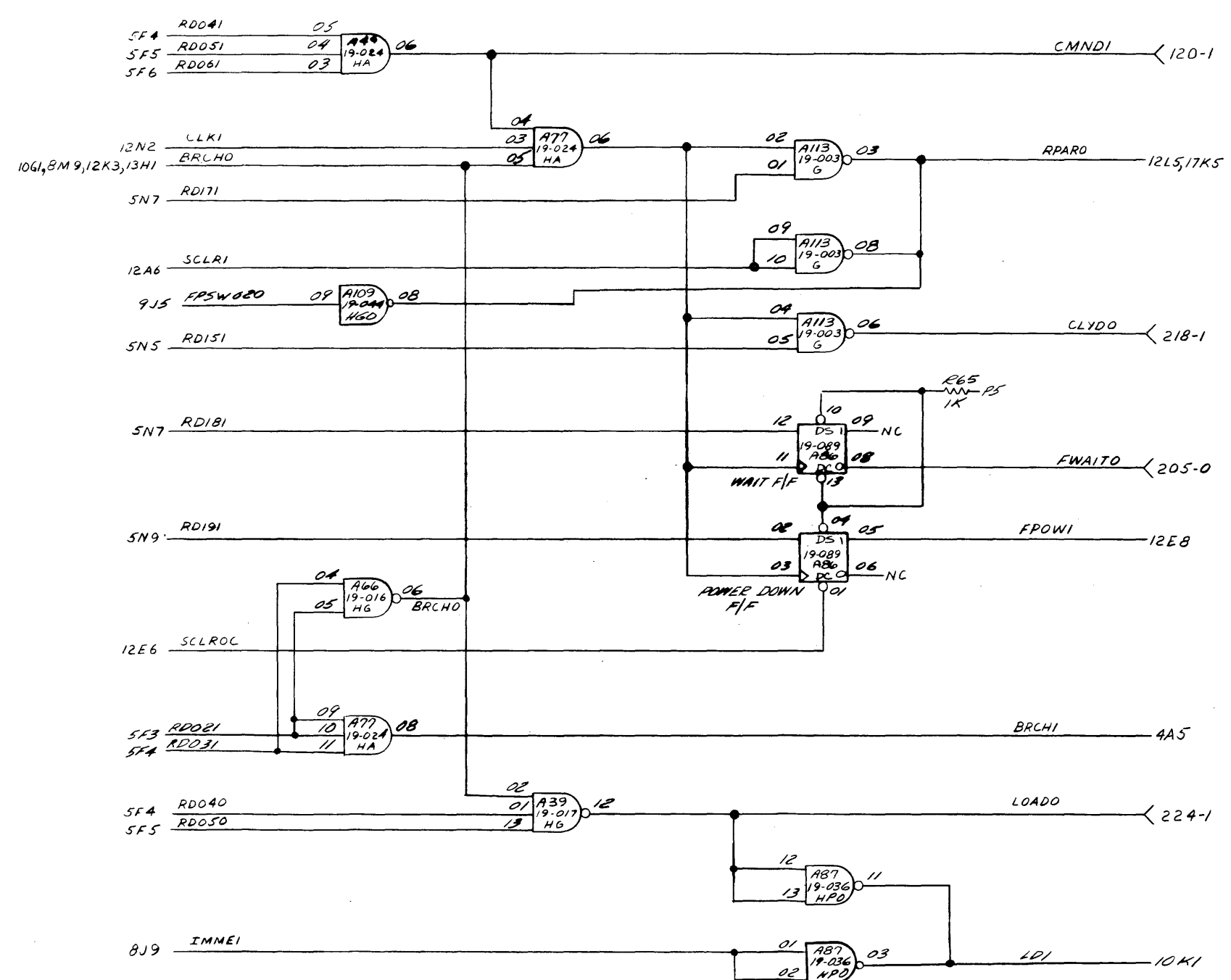

COMMAND DECODING

NOTES
 1. ALL APPARATUS THIS SHEET LOCATED ON CPUHI BOARD 35-446 (00, 11, 446, POLAND) 35-446 FOR UNLESS OTHERWISE SPECIFIED.

NAME	TITLE	DATE	TITLE
B GRAY	DRAFT		FUNCTIONAL SCHEMATIC
	CHK		PROCESSOR
	ENGR		TASK NO. 03012 SHEET OF 7-26
	DIR ENGR		NO. 01-058022 D08



REVISIONS		
REVISED	TITLE BLOCK	
PC 2033	11-2-73	EOI

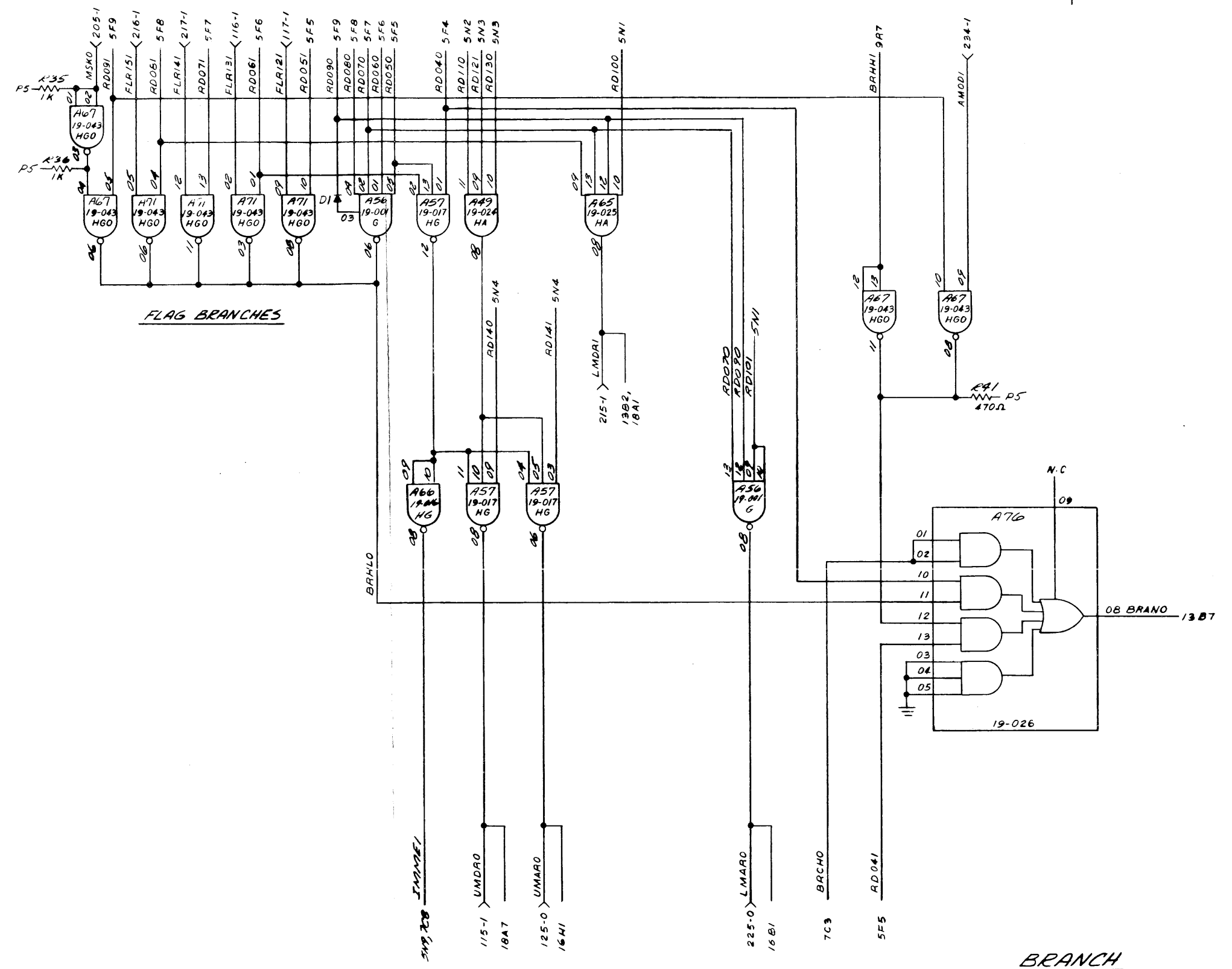

NOTES
 1. ALL APPARATUS THIS SHEET LOCATED ON
 CPUHI BOARD 35-446100. ALL APPARATUS
 35-446102 UNLESS OTHERWISE SPECIFIED.

NAME	TITLE	DATE	TITLE
STAN SILLS	DRAFT	11-4-72	FUNCTIONAL SCHEMATIC
	CHK		
	ENGR		
	DIR ENG		
TASK NO.	03016	SHEET OF	8-26
FILE NO.	01-058R01D08		



BRUNING 44-231 16042

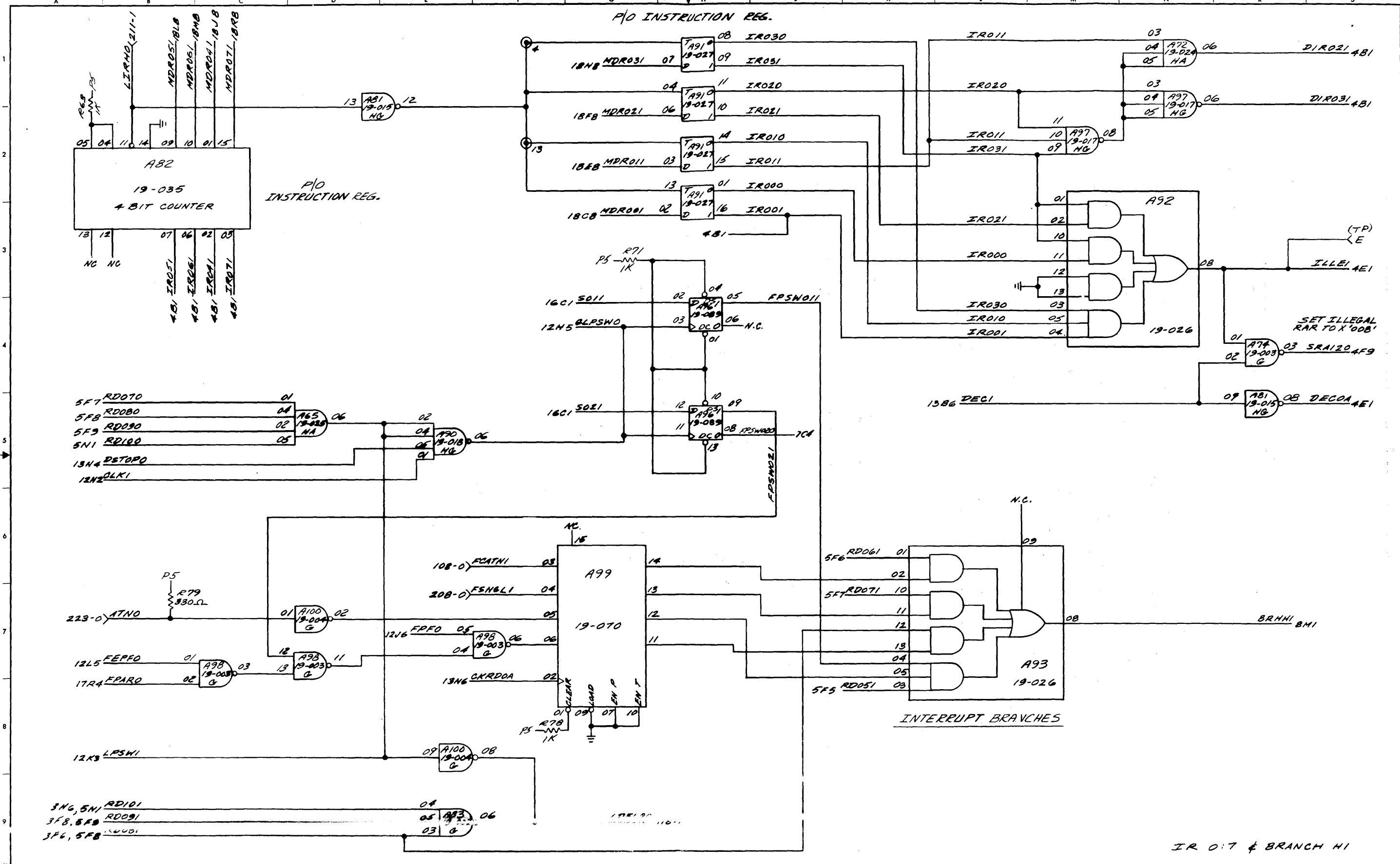

NOTES
 1. ALL APPARATUS ON THIS SHEET LOCATED ON CPU-M1 BOARD, 35-446F00, 35-446F01 AND 35-446F02 UNLESS OTHERWISE SPECIFIED.

REVISIONS		NAME	TITLE	DATE	TITLE
LOC EB	CRD08	E. ROE		11-4-72	FUNCTIONAL SCHEMATIC
BRN	1900/1914	RO1			
REVISED TITLE BLOCK					
PE	2033	12-13-73	RD2		

TASK NO	09018	SHEET OF	9-26
DRAWING NO	01-058902 DOB		

IR 0:7 & BRANCH HI

REVISIONS		
REVISED TITLE BLOCK	DATE	BY
2	11-13-73	RO1

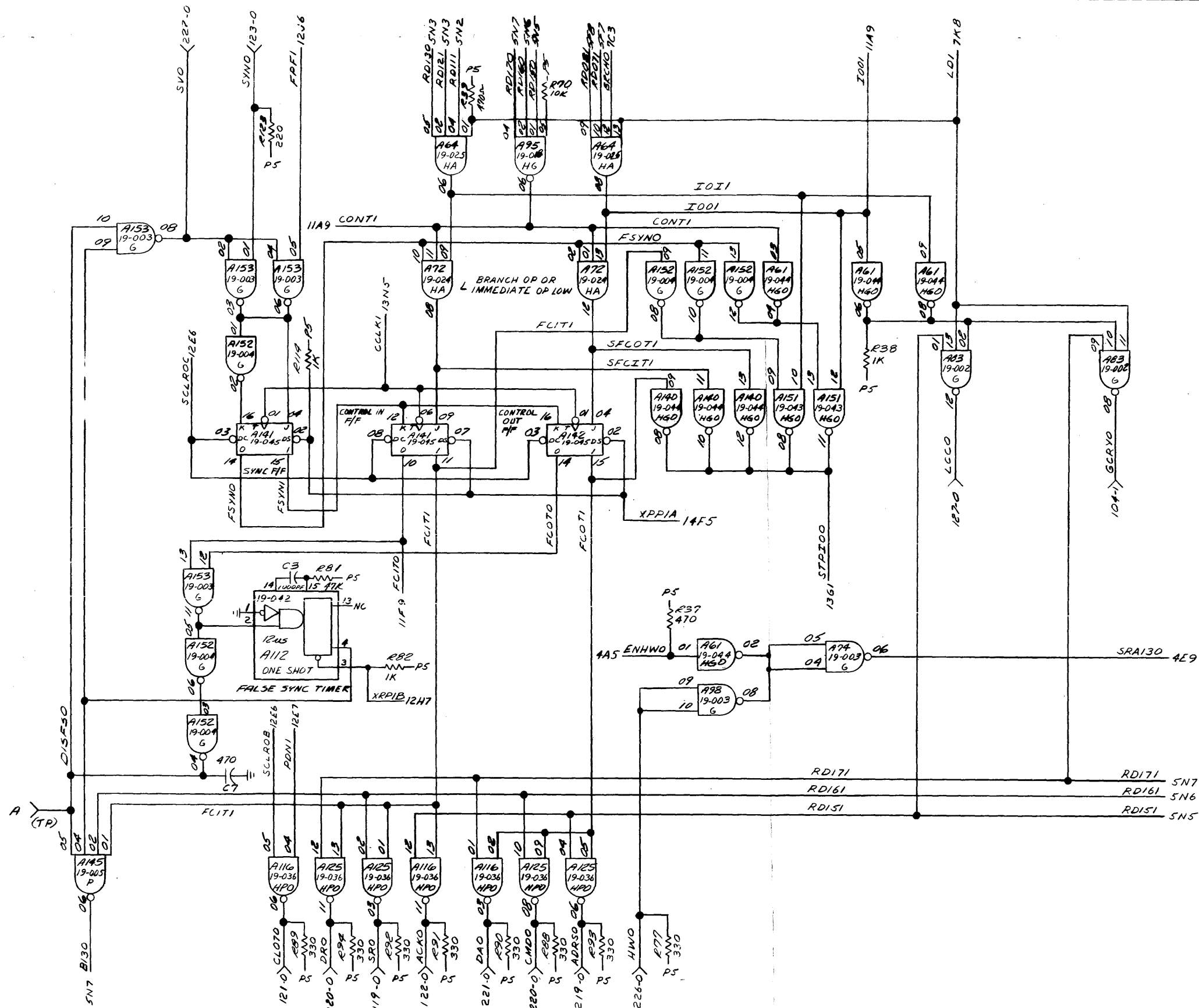

I/O CONTROL

NOTES
 1. ALL APPARATUS THIS SHEET LOCATED ON CPUHI BOARD 35-446F00, 35-446F01, AND 35-446F02 UNLESS OTHERWISE SPECIFIED.

NAME	TITLE	DATE	TITLE
B GRAY	DRAFT	11-6-72	FUNCTIONAL SCHEMATIC
	CHK		
	ENGR		
			PROCESSOR
			TASK NO. 03018
			SHEET OF 10-26
			DIR ENG. NO. 01-058ED1 D08



LOCATED ON CPUNI BOARD (35-446F00, 35-446F01, & 35-446F02)

LOCATED ON CPULO BOARD (35-447 & 35-520)

REVISIONS	
REVISED TITLE BLOCK	DATE
1	12-13-72
2	01-05-73

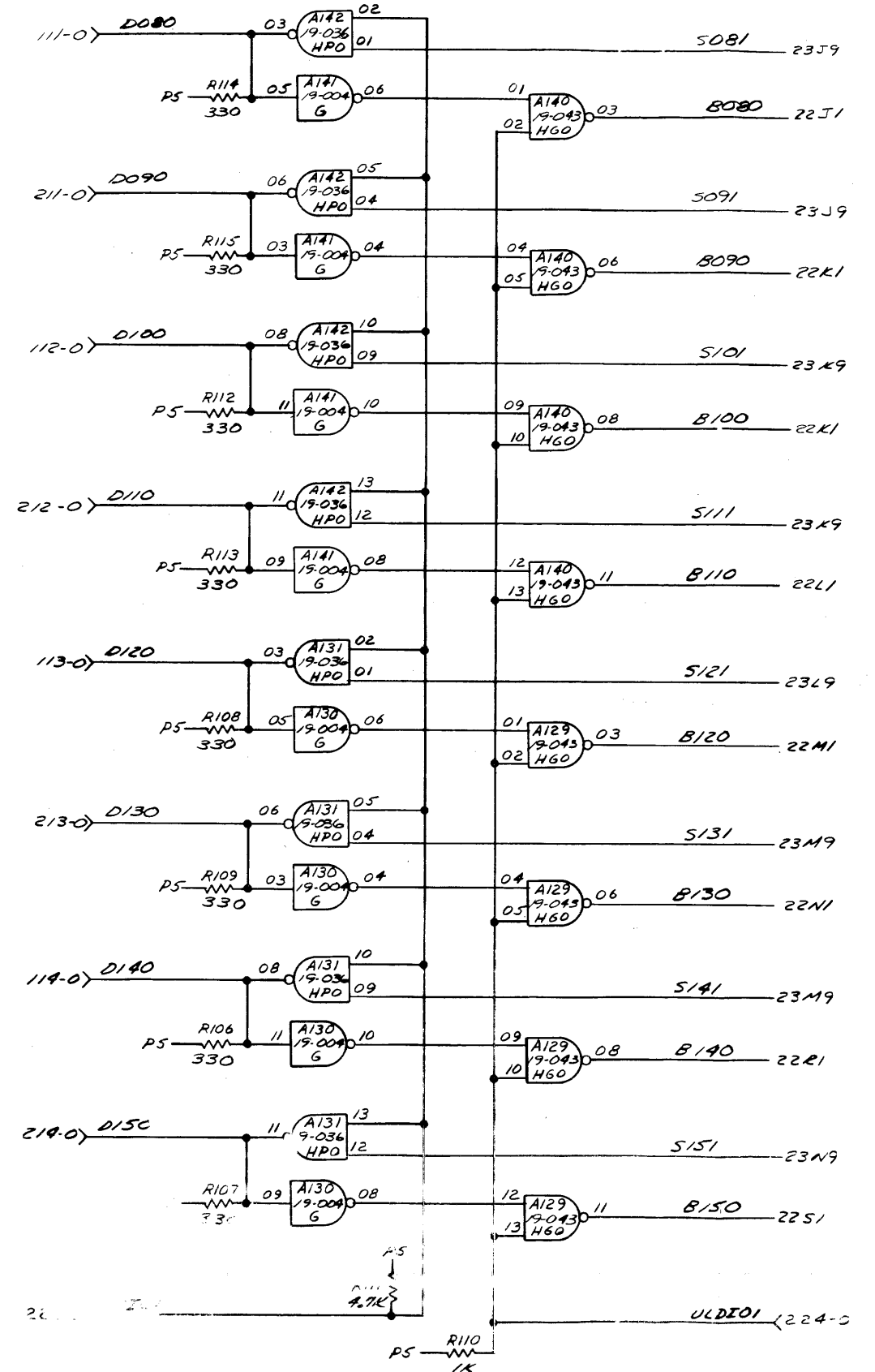
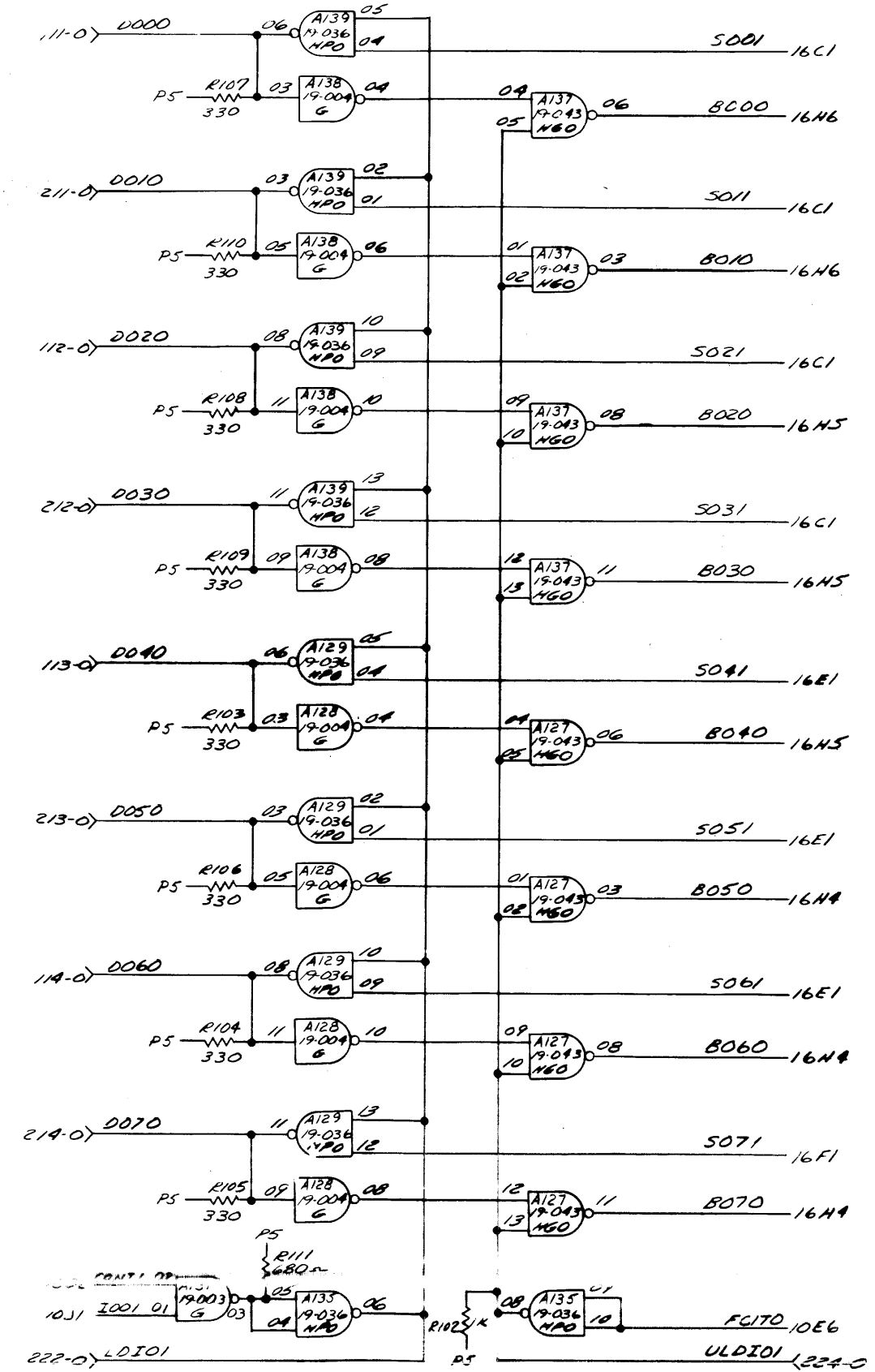

BRUNING 44-231 16042

NOTES

NAME	TITLE	DATE	TITLE
R. HEGINLEY	DRAFT	11-4-72	FUNCTIONAL SCHEMATIC
	CHK.		
	ENGR.		
	DIR. ENGR.		
	TASK NO.		
	03018		
	Q1-058 R01 008		
		SHEET OF	
		11-26	



REVISIONS			
AREA NO.:	ADDED	1002	RES.
P/	12-172	155	
HAZARD:	ADDED	ENTER	
HAZARD:	ADDED	1011	
REV.	1907	11/13/73	201
LEV.	12	7	202
REV.	1023	10/13/72	202
HAZARD:	ADDED	1135	
HAZARD:	ADDED	1132	
HAZARD:	ADDED	1131	
HAZARD:	ADDED	1130	
HAZARD:	ADDED	1129	
HAZARD:	ADDED	1128	
HAZARD:	ADDED	1127	
HAZARD:	ADDED	1126	
HAZARD:	ADDED	1125	
HAZARD:	ADDED	1124	
HAZARD:	ADDED	1123	
HAZARD:	ADDED	1122	
HAZARD:	ADDED	1121	
HAZARD:	ADDED	1120	
HAZARD:	ADDED	1119	
HAZARD:	ADDED	1118	
HAZARD:	ADDED	1117	
HAZARD:	ADDED	1116	
HAZARD:	ADDED	1115	
HAZARD:	ADDED	1114	
HAZARD:	ADDED	1113	
HAZARD:	ADDED	1112	
HAZARD:	ADDED	1111	
HAZARD:	ADDED	1110	
HAZARD:	ADDED	1109	
HAZARD:	ADDED	1108	
HAZARD:	ADDED	1107	
HAZARD:	ADDED	1106	
HAZARD:	ADDED	1105	
HAZARD:	ADDED	1104	
HAZARD:	ADDED	1103	
HAZARD:	ADDED	1102	
HAZARD:	ADDED	1101	
HAZARD:	ADDED	1100	

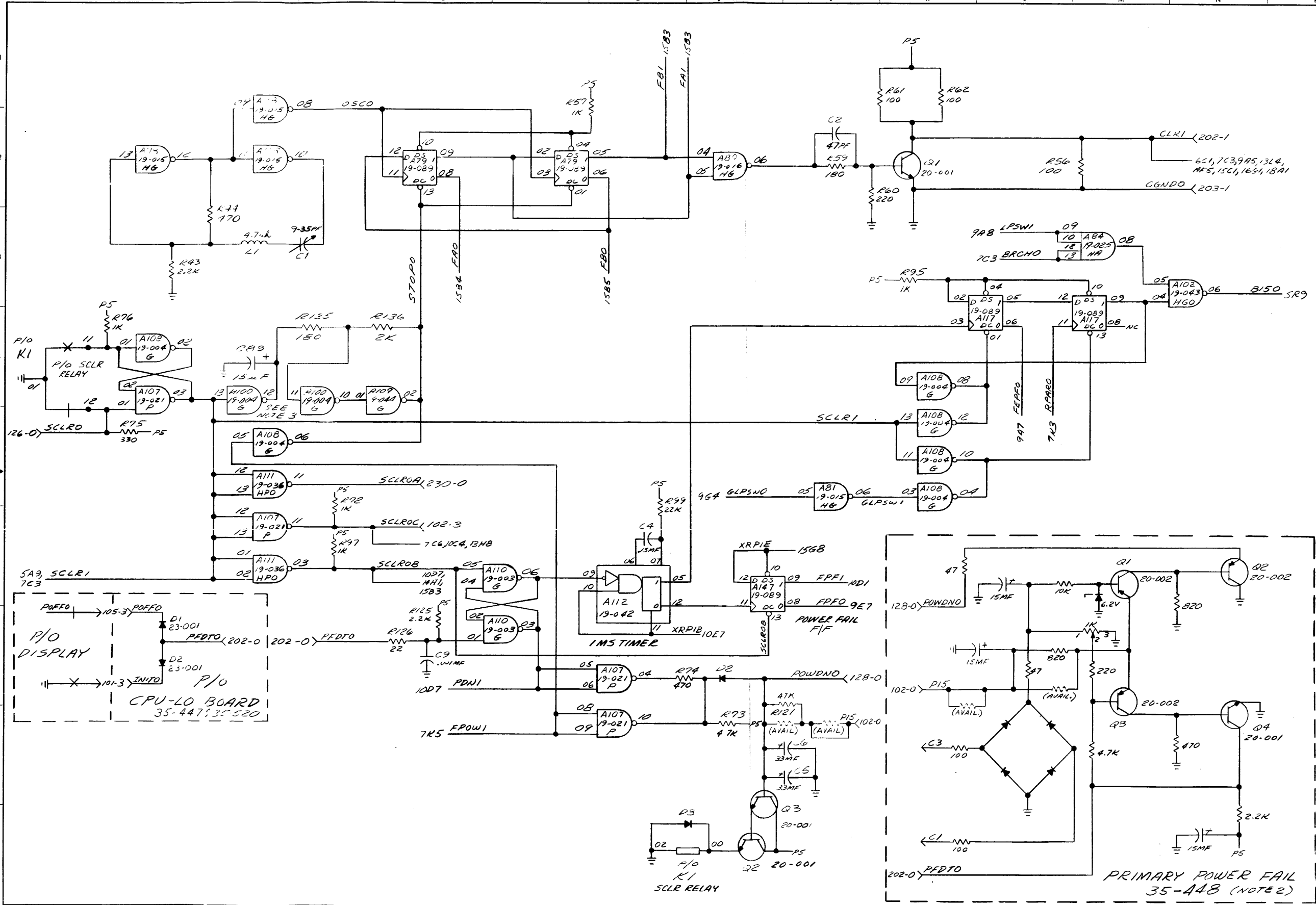

NOTES
 ALL APPARATUS ON THIS SHEET LOCATED ON CPU-MI BOARD 35-446
 THIS OPTION, WHEN EQUIPPED, IS INSTALLED IN THE BACKPANEL ON SLOT 6, CONNECTOR D.

3. 35-446 P/O ASSEMBLIES USING 25-355R02 LOGIC EMPLOY GATES A100 PINS 11 & 10 AND A132 PINS 05 & 06 INSTEAD OF A100 PINS 13 & 12 AND A100 PINS 11 & 10 REEP.

OSCILLATOR & INITIALIZE RELAY
 PRIMARY POWER FAIL 35-448 (NOTE 2)

NAME	TITLE	DATE	TITLE
P. MEGINLEY	DRAFT	11-9-72	FUNCTIONAL SCHEMATIC
	CHK		
	ENGR		
	DIR ENGR		
			PROCESSOR
			TASK NO. 03018
			REV. 01-058R03 DOB
			SHEET OF 12-26

REVISIONS	
REVISED TITLE BLOCK	
PC	10/23/73
1/14	12-13-73
1/01	

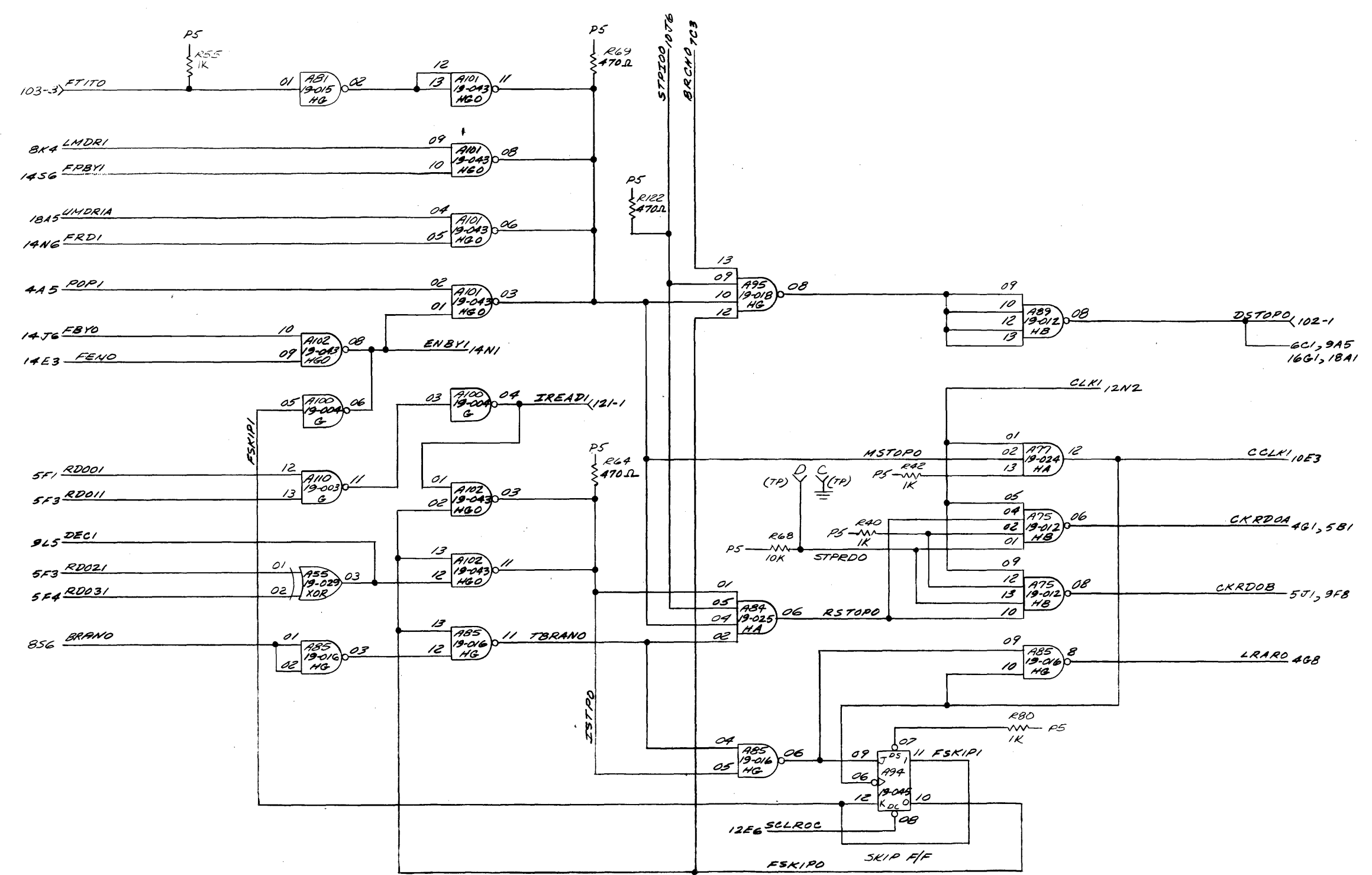

NOTES
 1. ALL APPARATUS ON THIS SHEET LOCATED ON CPU-MI BOARD, 35-446500, 35-446501, AND 35-446502 UNLESS OTHERWISE SPECIFIED.

CLOCK CONTROL

NAME	TITLE	DATE	TITLE
STAN SILLS	DRAFT	11-6-72	FUNCTIONAL SCHEMATIC
	CHK		
	ENGR		
	DIR ENG		



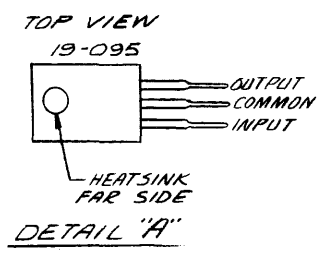
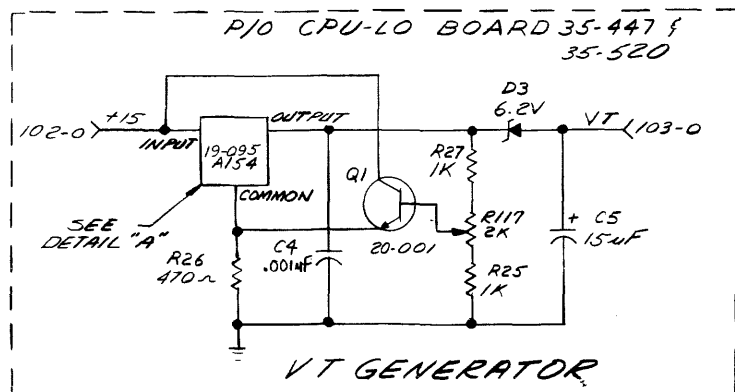
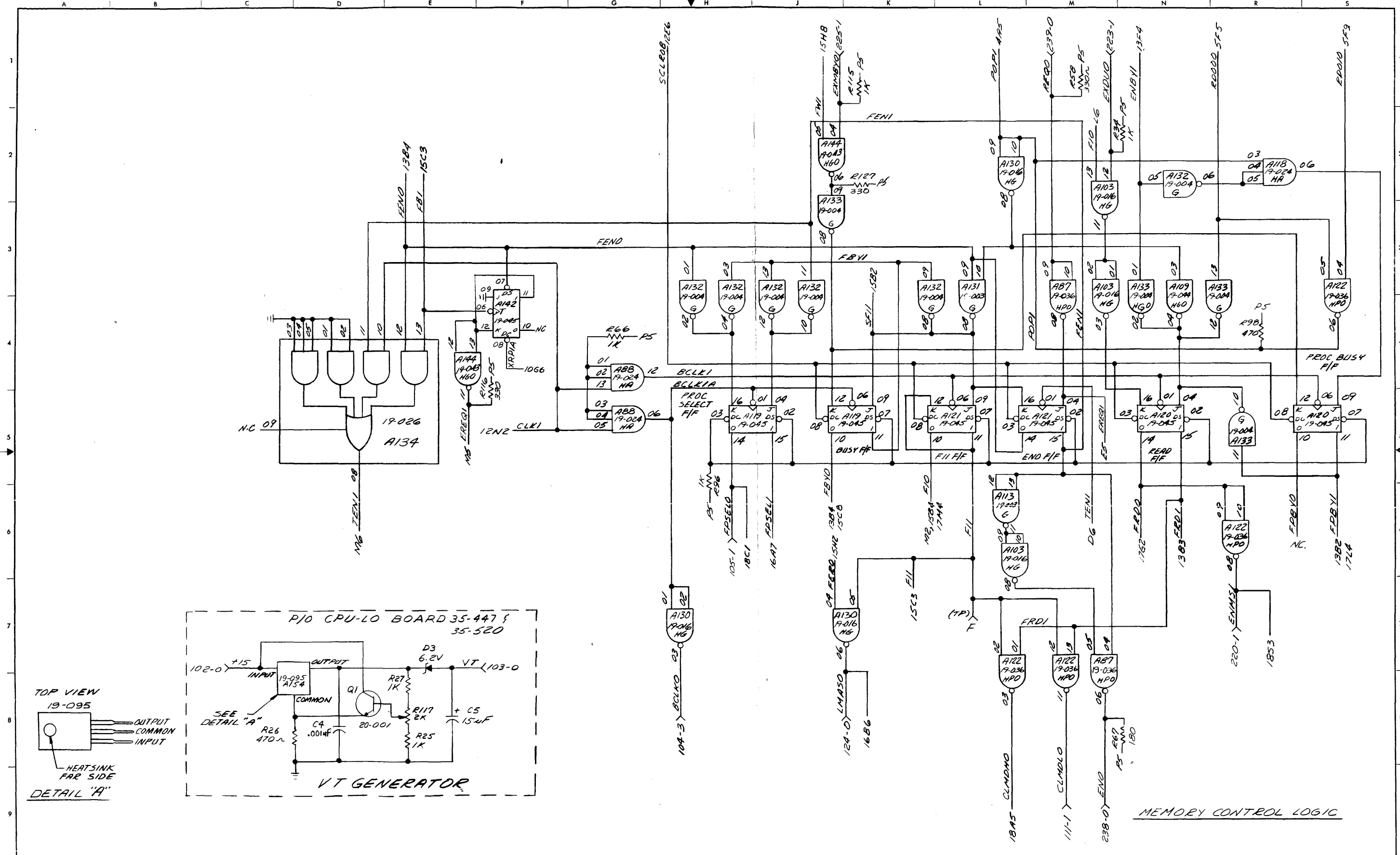

MEMORY CONTROL LOGIC

NOTES
 1. ALL APPARATUS ON THIS SHEET LOCATED ON CPU BOARD 35-446F00, 35-446F01, AND 35-446F02 UNLESS OTHERWISE SPECIFIED.

REVISED TITLE BLOCK	NAME	TITLE	DATE
REVISED TITLE BLOCK	R. MEGUNLEY	FUNCTIONAL SCHEMATIC	11-9-72
AREA N.B. REV WAS SPEC'D AS 330		PROCESSOR	
		TASK 03018	SHEET OF 26
		01-05-BEG-2-DR	14-26



REV 15, ONE
 REVISED TITLE BLOCK
 12/18/72 11/12/72 E01
 HREHS 12, 16, 18, 19, 20, 21, 22, 23, 24, 25, 26, 27, 28, 29, 30, 31, 32, 33, 34, 35, 36, 37, 38, 39, 40, 41, 42, 43, 44, 45, 46, 47, 48, 49, 50, 51, 52, 53, 54, 55, 56, 57, 58, 59, 60, 61, 62, 63, 64, 65, 66, 67, 68, 69, 70, 71, 72, 73, 74, 75, 76, 77, 78, 79, 80, 81, 82, 83, 84, 85, 86, 87, 88, 89, 90, 91, 92, 93, 94, 95, 96, 97, 98, 99, 100, 101, 102, 103, 104, 105, 106, 107, 108, 109, 110, 111, 112, 113, 114, 115, 116, 117, 118, 119, 120, 121, 122, 123, 124, 125, 126, 127, 128, 129, 130, 131, 132, 133, 134, 135, 136, 137, 138, 139, 140, 141, 142, 143, 144, 145, 146, 147, 148, 149, 150, 151, 152, 153, 154, 155, 156, 157, 158, 159, 160, 161, 162, 163, 164, 165, 166, 167, 168, 169, 170, 171, 172, 173, 174, 175, 176, 177, 178, 179, 180, 181, 182, 183, 184, 185, 186, 187, 188, 189, 190, 191, 192, 193, 194, 195, 196, 197, 198, 199, 200, 201, 202, 203, 204, 205, 206, 207, 208, 209, 210, 211, 212, 213, 214, 215, 216, 217, 218, 219, 220, 221, 222, 223, 224, 225, 226, 227, 228, 229, 230, 231, 232, 233, 234, 235, 236, 237, 238, 239, 240, 241, 242, 243, 244, 245, 246, 247, 248, 249, 250, 251, 252, 253, 254, 255, 256, 257, 258, 259, 260, 261, 262, 263, 264, 265, 266, 267, 268, 269, 270, 271, 272, 273, 274, 275, 276, 277, 278, 279, 280, 281, 282, 283, 284, 285, 286, 287, 288, 289, 290, 291, 292, 293, 294, 295, 296, 297, 298, 299, 300, 301, 302, 303, 304, 305, 306, 307, 308, 309, 310, 311, 312, 313, 314, 315, 316, 317, 318, 319, 320, 321, 322, 323, 324, 325, 326, 327, 328, 329, 330, 331, 332, 333, 334, 335, 336, 337, 338, 339, 340, 341, 342, 343, 344, 345, 346, 347, 348, 349, 350, 351, 352, 353, 354, 355, 356, 357, 358, 359, 360, 361, 362, 363, 364, 365, 366, 367, 368, 369, 370, 371, 372, 373, 374, 375, 376, 377, 378, 379, 380, 381, 382, 383, 384, 385, 386, 387, 388, 389, 390, 391, 392, 393, 394, 395, 396, 397, 398, 399, 400, 401, 402, 403, 404, 405, 406, 407, 408, 409, 410, 411, 412, 413, 414, 415, 416, 417, 418, 419, 420, 421, 422, 423, 424, 425, 426, 427, 428, 429, 430, 431, 432, 433, 434, 435, 436, 437, 438, 439, 440, 441, 442, 443, 444, 445, 446, 447, 448, 449, 450, 451, 452, 453, 454, 455, 456, 457, 458, 459, 460, 461, 462, 463, 464, 465, 466, 467, 468, 469, 470, 471, 472, 473, 474, 475, 476, 477, 478, 479, 480, 481, 482, 483, 484, 485, 486, 487, 488, 489, 490, 491, 492, 493, 494, 495, 496, 497, 498, 499, 500, 501, 502, 503, 504, 505, 506, 507, 508, 509, 510, 511, 512, 513, 514, 515, 516, 517, 518, 519, 520, 521, 522, 523, 524, 525, 526, 527, 528, 529, 530, 531, 532, 533, 534, 535, 536, 537, 538, 539, 540, 541, 542, 543, 544, 545, 546, 547, 548, 549, 550, 551, 552, 553, 554, 555, 556, 557, 558, 559, 560, 561, 562, 563, 564, 565, 566, 567, 568, 569, 570, 571, 572, 573, 574, 575, 576, 577, 578, 579, 580, 581, 582, 583, 584, 585, 586, 587, 588, 589, 590, 591, 592, 593, 594, 595, 596, 597, 598, 599, 600, 601, 602, 603, 604, 605, 606, 607, 608, 609, 610, 611, 612, 613, 614, 615, 616, 617, 618, 619, 620, 621, 622, 623, 624, 625, 626, 627, 628, 629, 630, 631, 632, 633, 634, 635, 636, 637, 638, 639, 640, 641, 642, 643, 644, 645, 646, 647, 648, 649, 650, 651, 652, 653, 654, 655, 656, 657, 658, 659, 660, 661, 662, 663, 664, 665, 666, 667, 668, 669, 670, 671, 672, 673, 674, 675, 676, 677, 678, 679, 680, 681, 682, 683, 684, 685, 686, 687, 688, 689, 690, 691, 692, 693, 694, 695, 696, 697, 698, 699, 700, 701, 702, 703, 704, 705, 706, 707, 708, 709, 710, 711, 712, 713, 714, 715, 716, 717, 718, 719, 720, 721, 722, 723, 724, 725, 726, 727, 728, 729, 730, 731, 732, 733, 734, 735, 736, 737, 738, 739, 740, 741, 742, 743, 744, 745, 746, 747, 748, 749, 750, 751, 752, 753, 754, 755, 756, 757, 758, 759, 760, 761, 762, 763, 764, 765, 766, 767, 768, 769, 770, 771, 772, 773, 774, 775, 776, 777, 778, 779, 780, 781, 782, 783, 784, 785, 786, 787, 788, 789, 790, 791, 792, 793, 794, 795, 796, 797, 798, 799, 800, 801, 802, 803, 804, 805, 806, 807, 808, 809, 810, 811, 812, 813, 814, 815, 816, 817, 818, 819, 820, 821, 822, 823, 824, 825, 826, 827, 828, 829, 830, 831, 832, 833, 834, 835, 836, 837, 838, 839, 840, 841, 842, 843, 844, 845, 846, 847, 848, 849, 850, 851, 852, 853, 854, 855, 856, 857, 858, 859, 860, 861, 862, 863, 864, 865, 866, 867, 868, 869, 870, 871, 872, 873, 874, 875, 876, 877, 878, 879, 880, 881, 882, 883, 884, 885, 886, 887, 888, 889, 890, 891, 892, 893, 894, 895, 896, 897, 898, 899, 900, 901, 902, 903, 904, 905, 906, 907, 908, 909, 910, 911, 912, 913, 914, 915, 916, 917, 918, 919, 920, 921, 922, 923, 924, 925, 926, 927, 928, 929, 930, 931, 932, 933, 934, 935, 936, 937, 938, 939, 940, 941, 942, 943, 944, 945, 946, 947, 948, 949, 950, 951, 952, 953, 954, 955, 956, 957, 958, 959, 960, 961, 962, 963, 964, 965, 966, 967, 968, 969, 970, 971, 972, 973, 974, 975, 976, 977, 978, 979, 980, 981, 982, 983, 984, 985, 986, 987, 988, 989, 990, 991, 992, 993, 994, 995, 996, 997, 998, 999, 1000

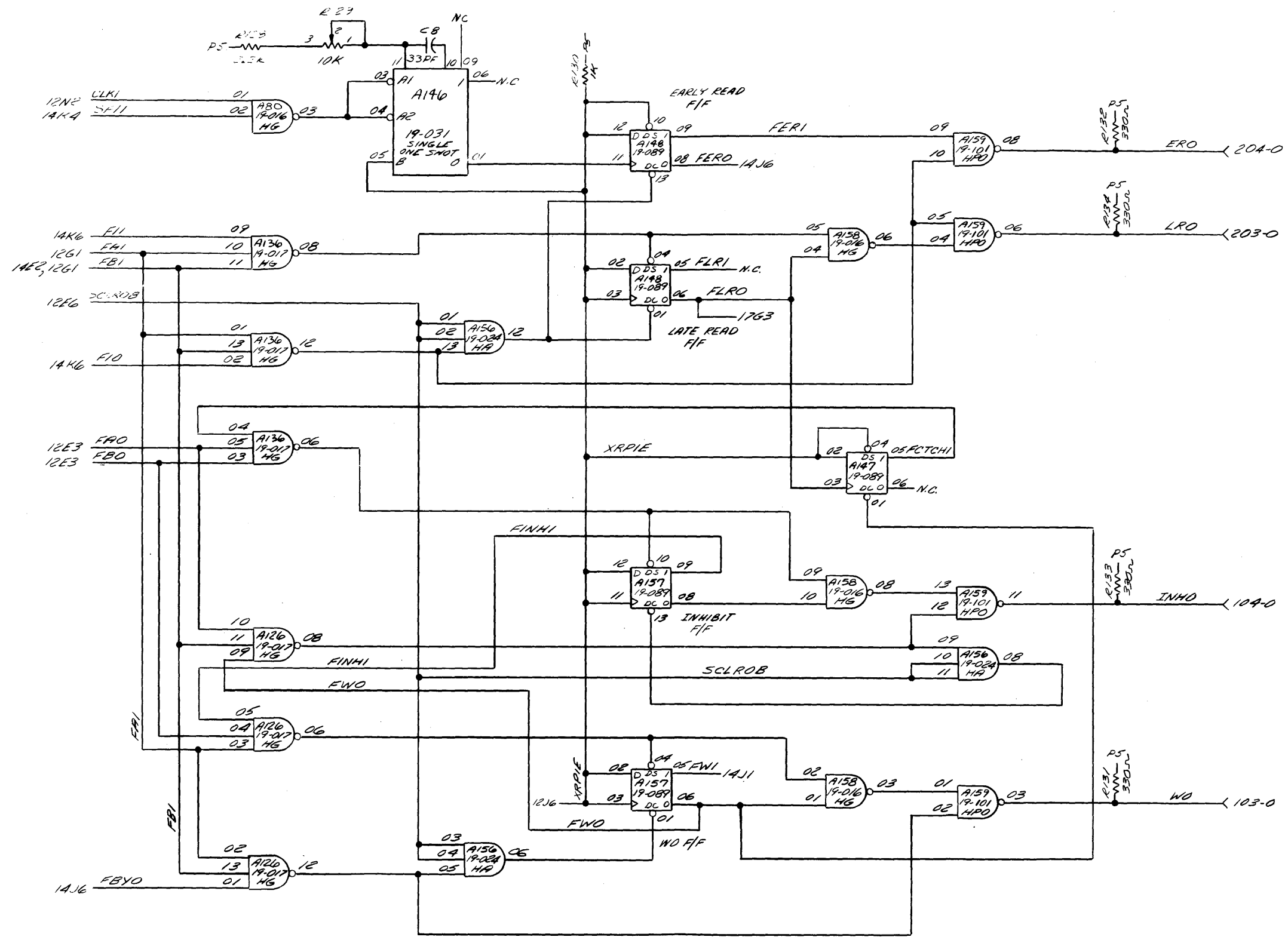

NOTES
 1. ALL APPARATUS ON THIS SHEET IS LOCATED ON CPU-M1 BOARD
 2. ALL SIGNALS ARE ACTIVE LOW UNLESS OTHERWISE SPECIFIED.

MEMORY TIMING

NAME	TITLE	DATE	TITLE
P. EDWARDS	DRAFT	11-5-72	FUNCTIONAL SCHEMATIC
	CHK		PROCESSOR
	ENGR		
	DIR ENG		

REV NO: 03018
 SHEET OF: 15-26
 DIR NO: 01-058, 002, 008

BRUNING 44-231 16042

REVISIONS		
11	11	11-11-72
ALL 11 MTS, MTS LEAD...		
WITHOUT PARITY OPTION		
10	11	11-11-72
REVISED TITLE BLOCK		
12	11	11-11-72
REVISED TITLE BLOCK		

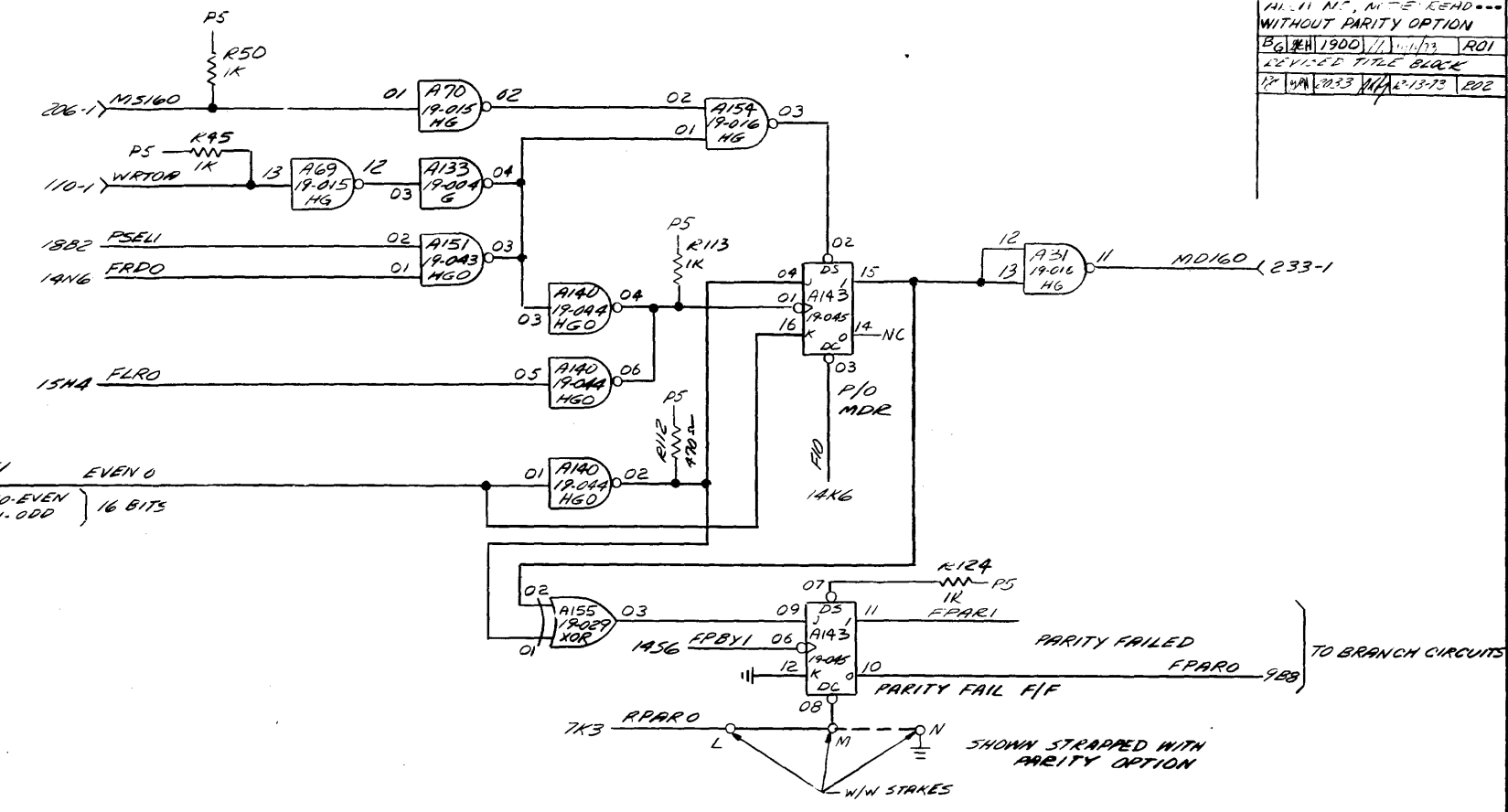
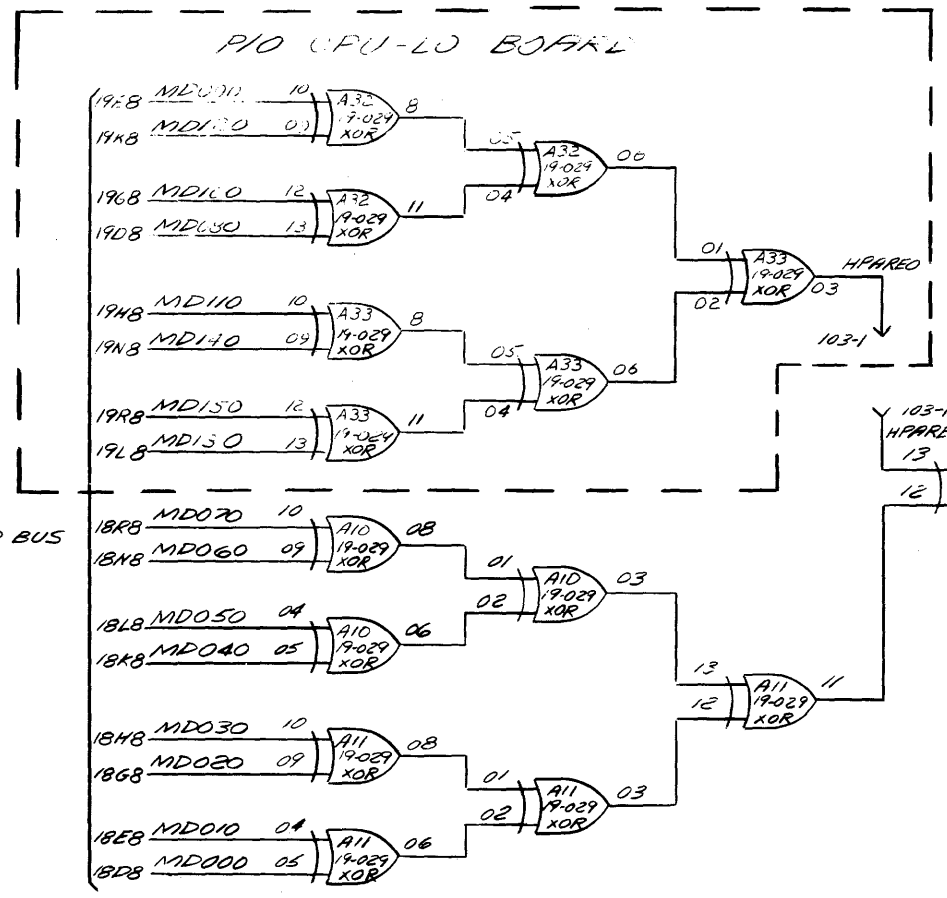

NOTES
 1. ALL APPARATUS ON THIS SHEET IS LOCATED ON CPU-MI BOARD, 35-446 FOR 35-446-10 AND 35-446-11. SEE DRAWING 35-446-10 FOR BOARD LAYOUT.

MEMORY PARITY			
NAME	TITLE	DATE	TITLE
REDWARS	DRAFT	11-2-72	FUNCTIONAL SCHEMATIC
	CHK		PROCESSOR
	ENGR		
	DIR ENG		
			REV 03016
			SHEET OF 17-26
			01-05BRO2 DCA

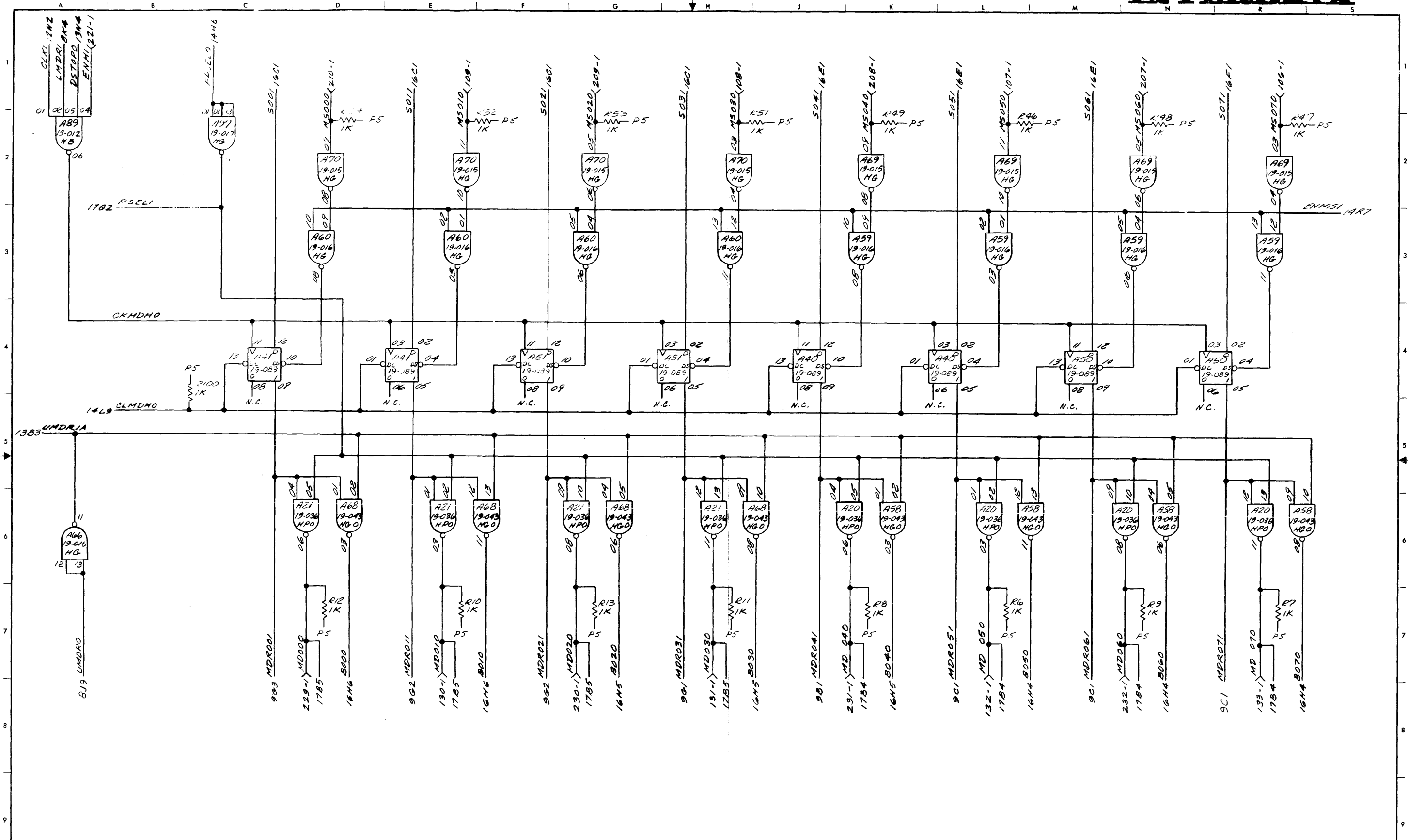

NOTES
 1. ALL APPARATUS ON THIS SHEET LOCATED ON CPU-MI BOARD, 35-446 F07, 35-446 F04 AND 35-446 F05

MEMORY DATA REGISTER HIGH

REV 15-01-72	NAME	TITLE	DATE	TITLE
REV 15-01-72	E. ROE	FUNCTIONAL SCHEMATIC	11-4-72	PROCESSOR
CHK				TASK NO. 0301B
ENGR				SHEET OF 18-26
DIR ENG				01-059001 D08

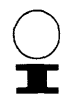

BRUNNIN 44 231 1604Z

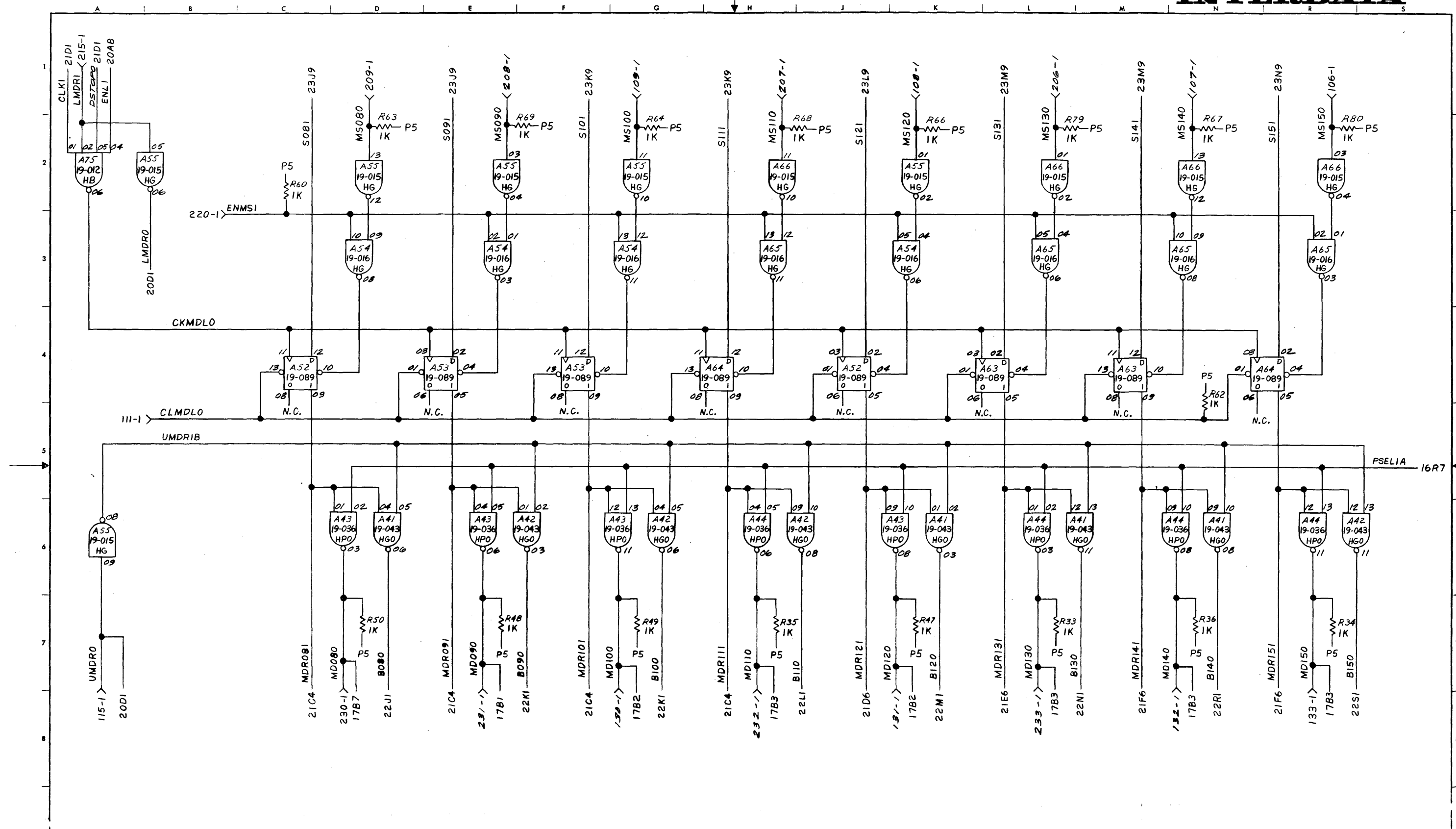

MEMORY DATA REGISTER LOW

NOTES
 1. ALL APPARATUS ON THIS SHEET LOCATED ON
 CPU-LO BOARD 35-447 AND 35-504 UNLESS
 OTHERWISE SPECIFIED.

REVISIONS		NAME	TITLE	DATE
REVISED	TITLE BLOCK	K. LAFFERTY	FUNCTIONAL SCHEMATIC	11-4-72
REVISED	2033		PROCESSOR	

TASK NO. 03018	SHEET OF 19-26
DIR ENG	



REVISIONS	
A74-12	WAS SHOWN AS INV.
B6	REVISED TO 1900 FROM 1911/13/RO1
F2	REVISED TO TIT. & BLOCK
F2	REVISED TO 2033 FROM 1911/13/2022

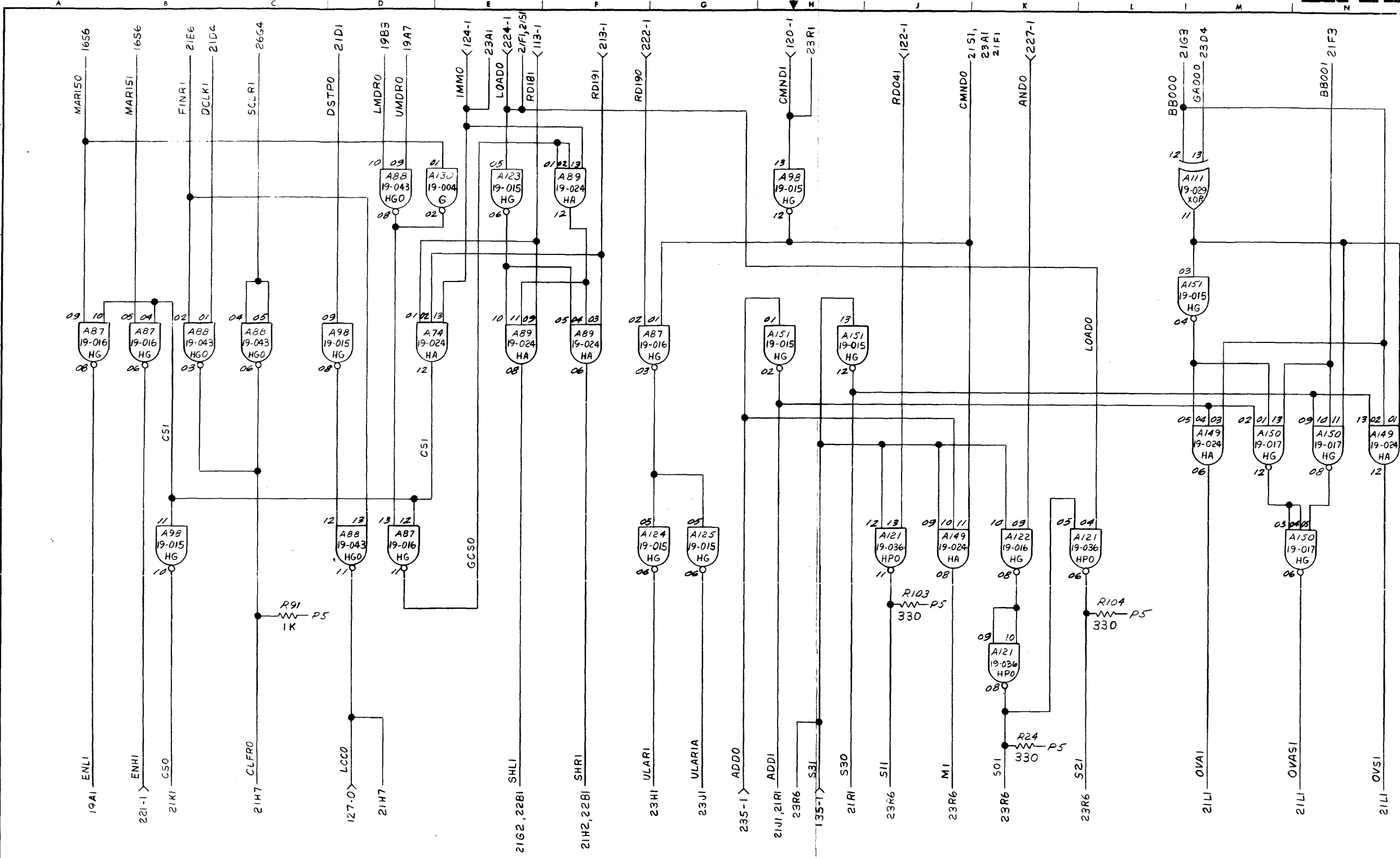

ADDRESS INPUTS	DATA INPUTS	STROBE	OUTPUT
B A	C0 C1 C2 C3	G	Y
x x	x x x x x x	/	H, Z
/ /	/ / / / / /	0	/ /
/ /	/ / / / / /	0	/ /
/ /	/ / / / / /	0	/ /
/ /	/ / / / / /	0	/ /
/ /	/ / / / / /	0	/ /
/ /	/ / / / / /	0	/ /
/ /	/ / / / / /	0	/ /
/ /	/ / / / / /	0	/ /

TRUTH TABLE FOR 19-073 4 TO 1 MUX SHEET 22

ALU CONTROL

NOTES
1. ALL APPARATUS ON THIS SHEET LOCATED ON CPU-LO BOARD 35-447 AND 35-500 UNLESS OTHERWISE SPECIFIED.

NAME K. LAFFERTY	TITLE DRAFT	DATE 11-4-72	TITLE FUNCTIONAL SCHEMATIC
	CHKR		PROCESSOR
	ENGR		
	DIR ENG		
			TASK NO. 03018
			SHEET OF 20-26
			REV. NO. 01-058, R02, R08



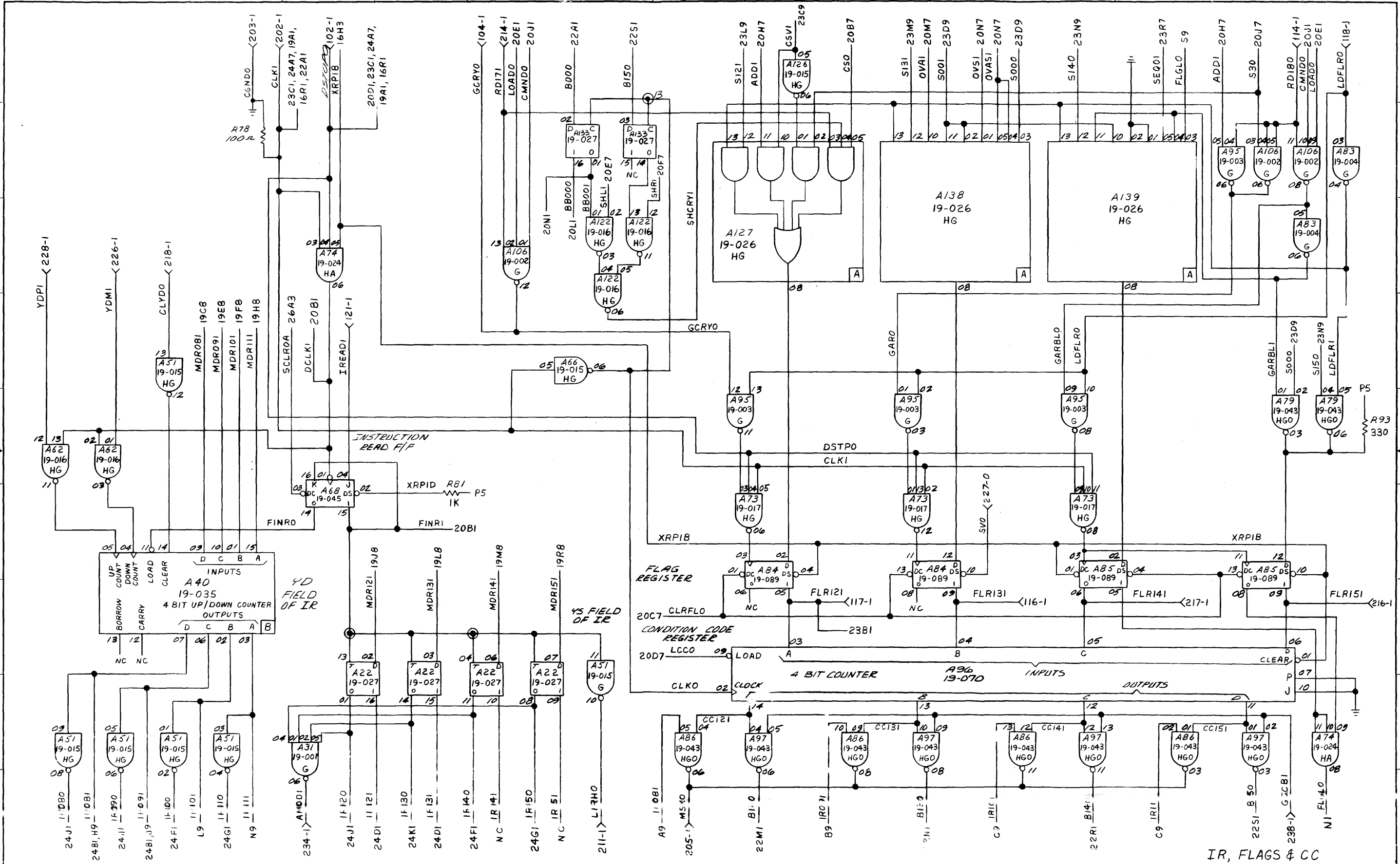

NOTES
 1. ALL APPARATUS THIS SHEET LOCATED ON CPU-LO BOARD 35-447
 OTHER WISE SPECIFIED.

REVISED TITLE BLOCK		NAME	TITLE	DATE	TITLE FUNCTIONAL SCHEMATIC
2033 11-6-72		K. LAFFERTY	DRAFT	11-6-72	PROCESSOR
2033 11-6-72			CHK		
2033 11-6-72			ENGR		
2033 11-6-72			DIR. ENG.		

TASK NO. 03018 SHEET OF 21-26
 01-058201 008

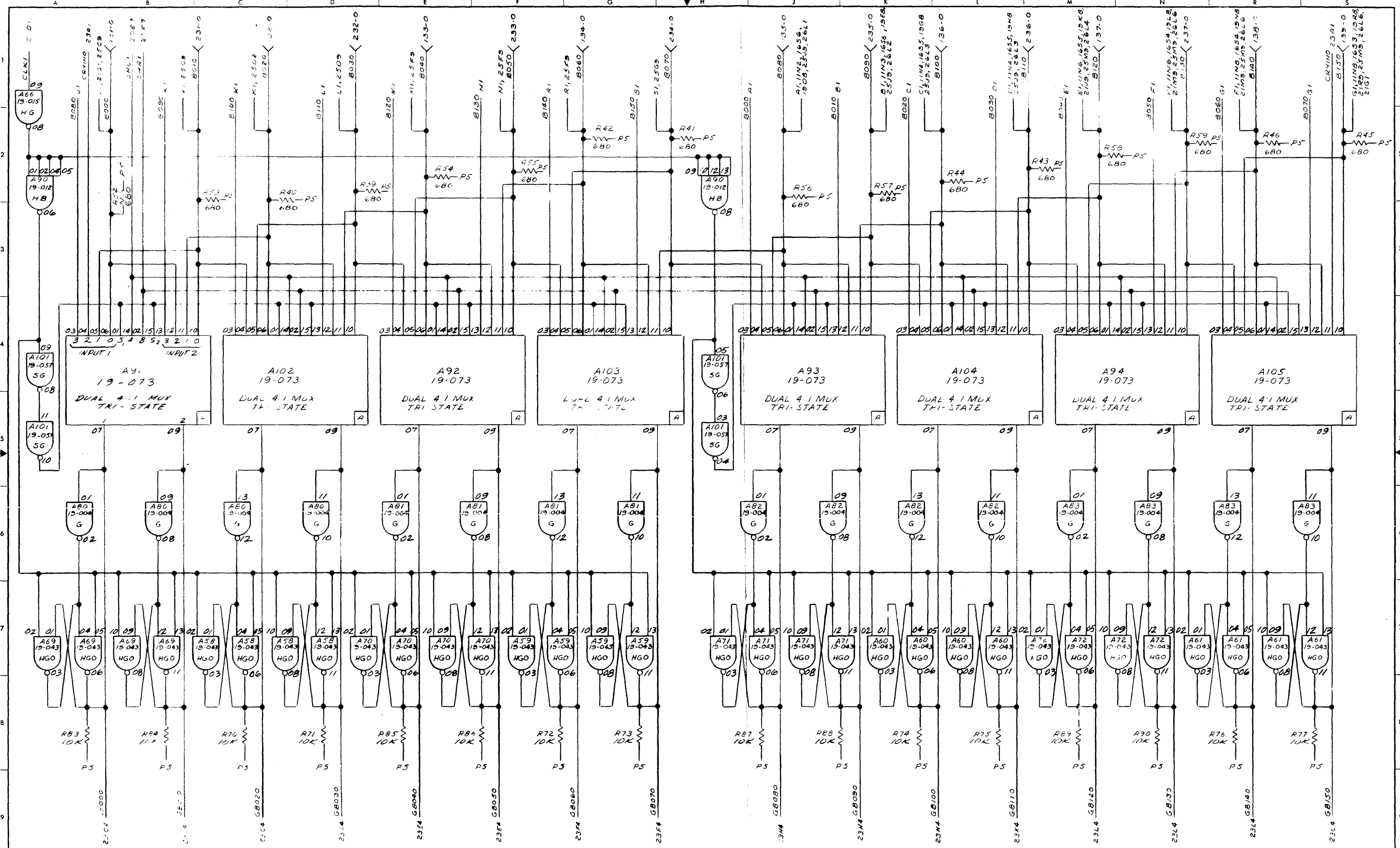

NOTES
 1. ALL COMPONENTS ON THIS SHEET LOCATED ON (P11) BOARD, 35-447 AND 35-520
 2. UNLESS OTHERWISE SPECIFIED.

REVISIONS		NAME	TITLE	DATE	TITLE
1	REVISED TITLE BLOCK	W. J. G. ...	FUNCTIONAL SCHEMATIC	11/2/72	PROCESSOR
2

DIR ENG	03018	SHEET OF
01-058601 008		22-26

SHIFTER & LATCH



REVISIONS	
REVISED TITLE	BLOCK
18	11/20/73
19	12/13/73
20	R01

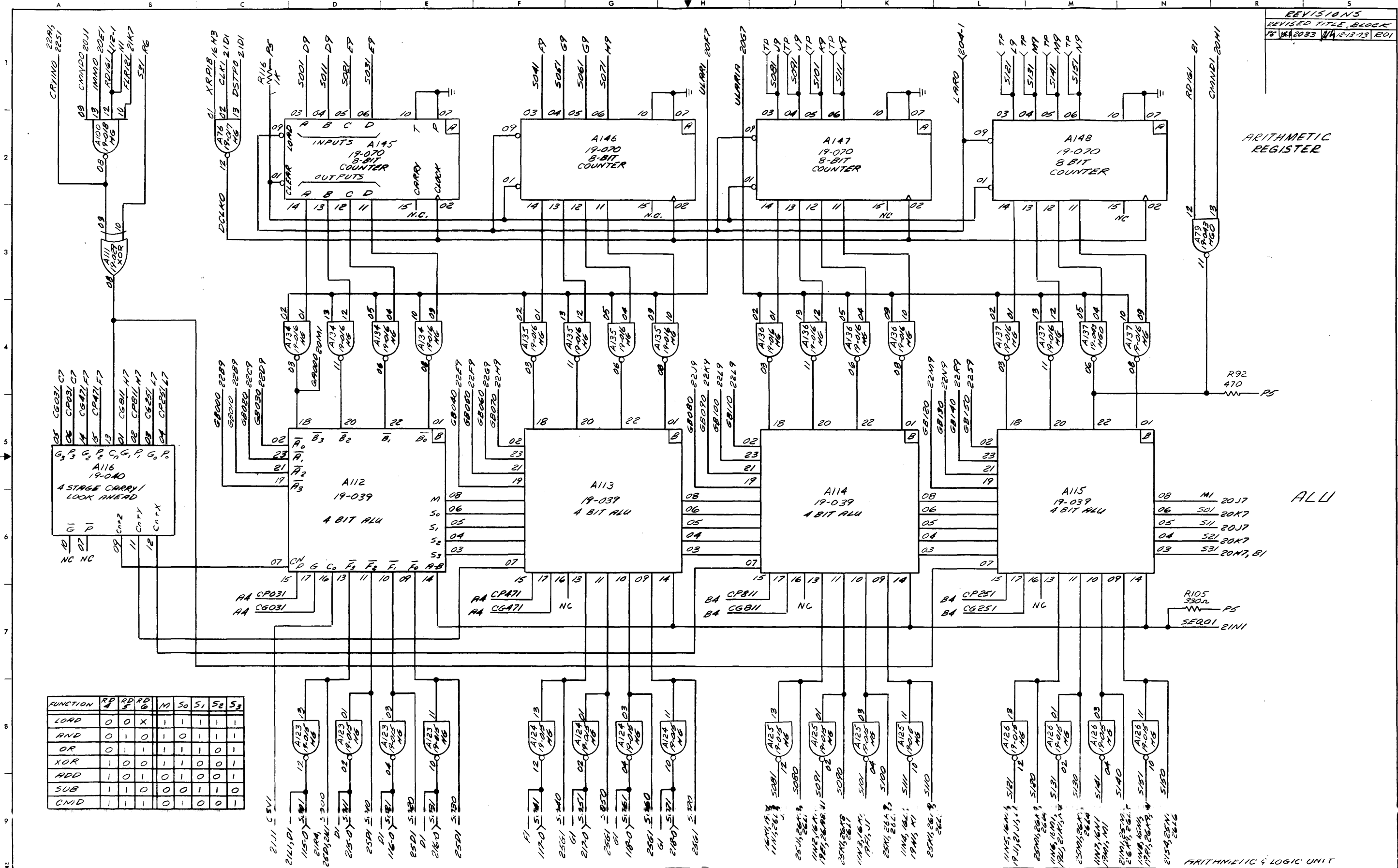

NOTES
 1. ALL APPARATUS ON THIS SHEET IS LOCATED ON CPU-10, 35-447 AND 35-520 UNLESS OTHERWISE SPECIFIED.

NAME	TITLE	DATE	TITLE
P. EDWARDS	DRAFT		FUNCTIONAL SCHEMATIC
	CHK		PROCESSOR
	ENGR		TASK NO. 03018
	DIR ENGR		SHEET OF 23-26
			01-058.E01 D08

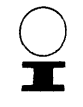

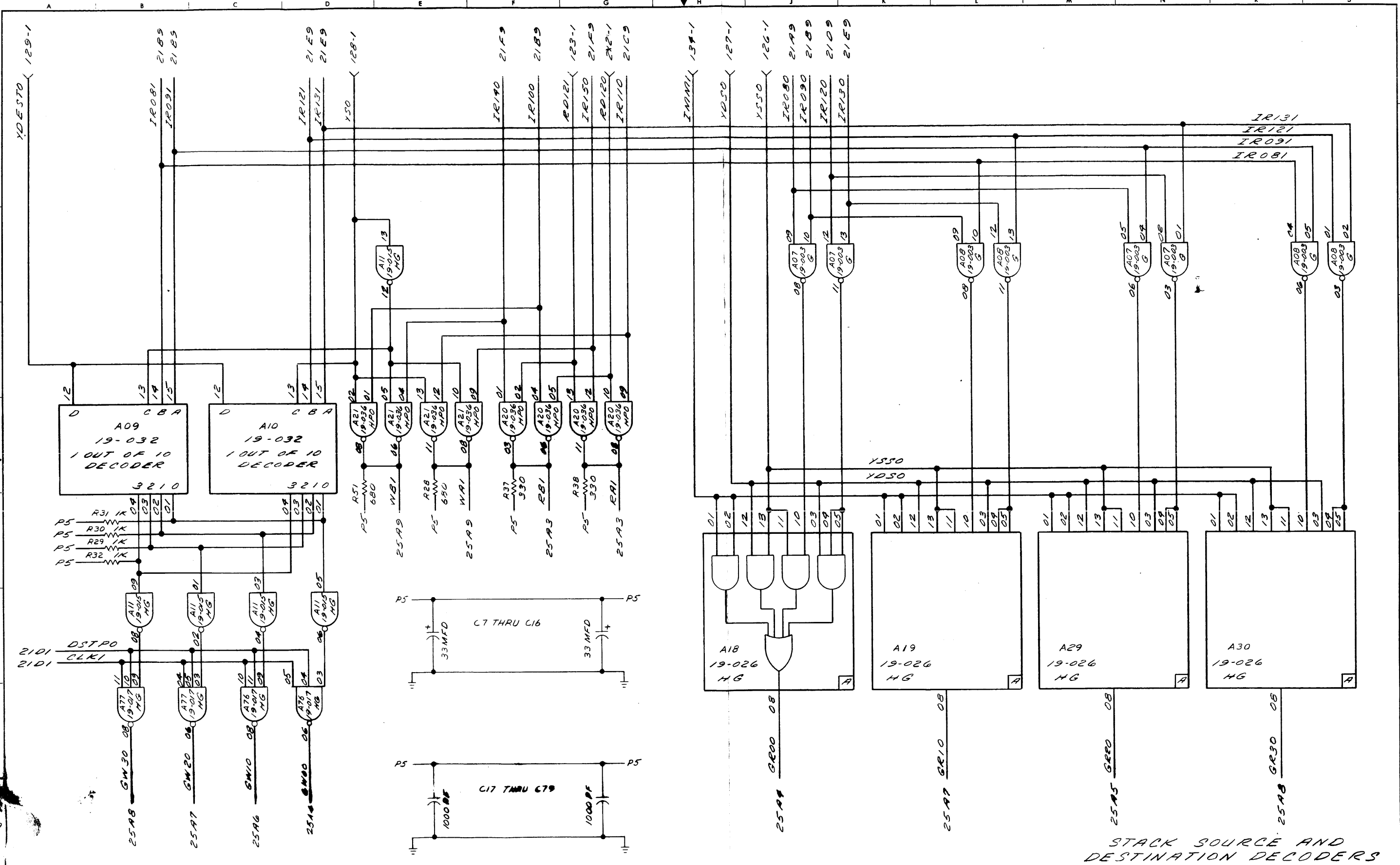

STACK SOURCE AND DESTINATION DECODERS

NOTES
 ALL APPARATUS ON THIS SHEET LOCATED ON CHU 10 UNLESS SPECIFIED OTHERWISE.

REVISIONS		NAME	TITLE	DATE	TITLE
330	LOC E6 R51; R28 WERE	R F CERO	DRAFT	4/10/72	FUNCTIONAL SCHEMATIC
331	BG NEW 1900 W/ 11/10/72 RO		CHK		PROCESSOR
	REVISED TITLE BLOCK		ENGR		0301B
	BY 2033 W/ 12/13/72 VEA		DIR ENGR		01-05B R02 DOB

SHEET OF 24-26

REVISIONS		
REVISED	TITLE	BLOCK
2	2033	114
1	1213-72	201

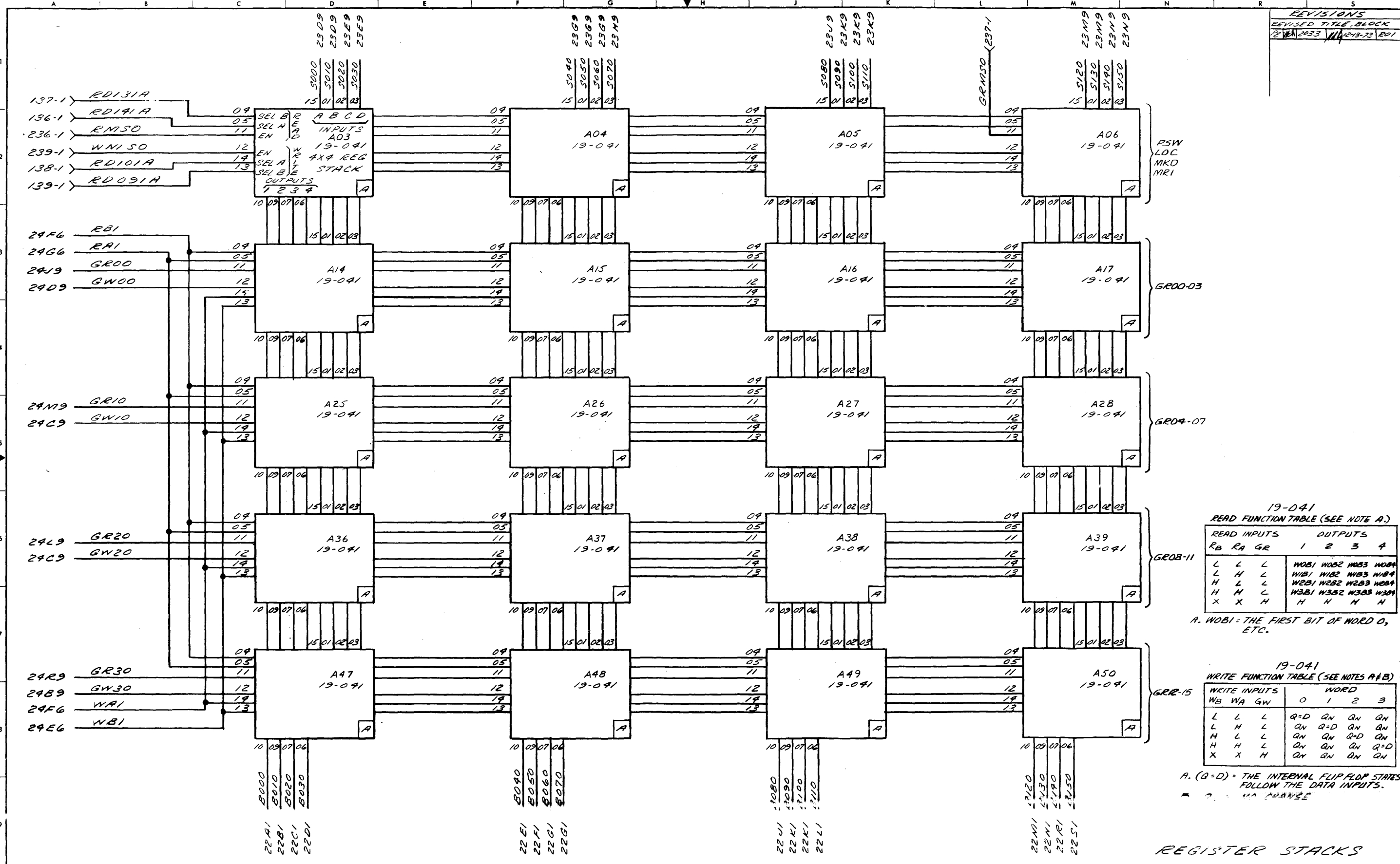

19-041
READ FUNCTION TABLE (SEE NOTE A.)

READ INPUTS			OUTPUTS			
Rb	Ra	Gr	1	2	3	4
L	L	L	W0B1	W0B2	W0B3	W0B4
L	H	L	W1B1	W1B2	W1B3	W1B4
H	L	L	W2B1	W2B2	W2B3	W2B4
H	H	L	W3B1	W3B2	W3B3	W3B4
X	X	H	H	H	H	H

A. W0B1 - THE FIRST BIT OF WORD 0, ETC.

19-041
WRITE FUNCTION TABLE (SEE NOTES A & B)

WRITE INPUTS			WORD			
Wb	Wa	Gw	0	1	2	3
L	L	L	Q=D	Qn	Qn	Qn
L	H	L	Qn	Q=D	Qn	Qn
H	L	L	Qn	Qn	Q=D	Qn
H	H	L	Qn	Qn	Qn	Q=D
X	X	H	Qn	Qn	Qn	Qn

A. (Q=D) = THE INTERNAL FLIP FLOP STATES FOLLOW THE DATA INPUTS.
B. Q = NO CHANGE

NOTES
ALL APPARATUS ON THIS SHEET LOCATED ON CPU-10 BOARD 35-497 AND 35-520 UNLESS OTHERWISE SPECIFIED.

NAME	TITLE	DATE	TITLE
R F CERD	DRAFT	4 NOV 72	FUNCTIONAL SCHEMATIC
CHK	ENGR		PROCESSOR
DIR ENG			0301B
			01-058201 D08

SHEET OF 25-26

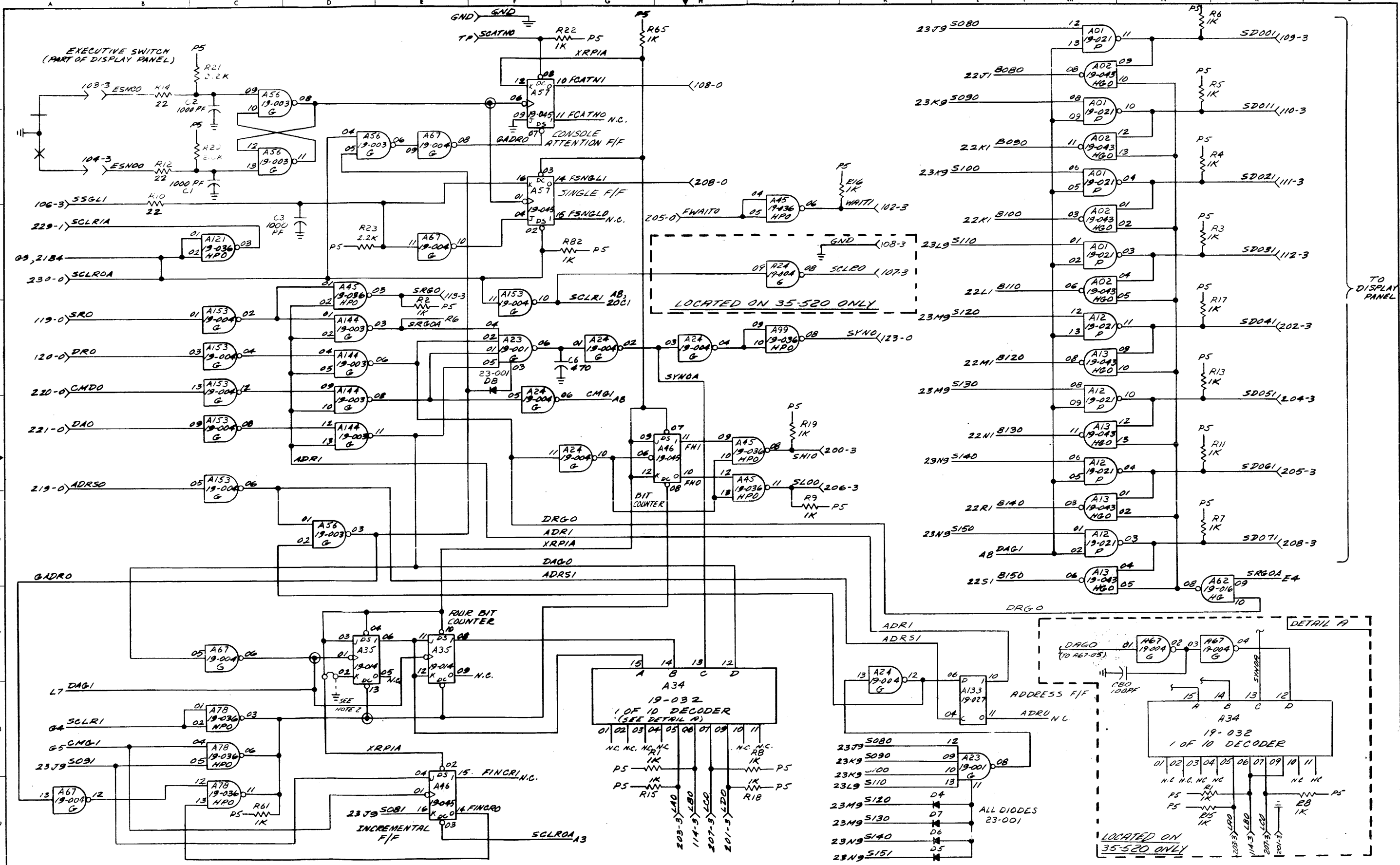

NOTES
 1. ALL APPARATUS ON THIS SHEET LOCATED ON CPU-LO BOARD, 35-447 AND 35-520 UNLESS OTHERWISE SPECIFIED.

2. FOR 35-447, PIN2 CONNECTS TO PIN3 OF I.C. A35.
 FOR 35-520, PIN2 IS GROUNDED.

ADDS J3 (R8)
 ADDED CIRCUITRY IN DASHED BOXES FOR 35-520 BD. REVISED TITLE BLOCK

REVISIONS
 LOC. C3, C3 WAS 470PF LOC. C7, A9 19-004 WAS 19-015 FOR 35-520 BD. LOC. C1 DELETED 19-004 ONE BETWEEN A56-08 & A57-06

NAME	TITLE	DATE	TITLE
E. ROE	FUNCTIONAL SCHEMATIC	11-6-72	PROCESSOR
	CHK		
	ENGR		
	DIR ENG		

26-26

BRUNING 44-231 16042

NOTES:
 1. SUFFERER BAR, ITEM 3, SHALL BE SOLDERED TO GND PINS AT 2 END POINTS & CENTER POINT.
 2. SOLDER PINS CLOSEST TO EDGE OF BOARD TO BE GENT INWARD PRIOR TO SOLDERING.

6
 MOUNT ON A-PARTIAL SIDE B PLACES

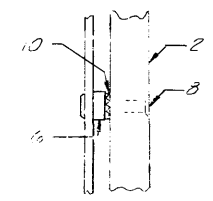

14.830 REF.

15.380 REF.

81 TYP 2 PLACES

SEE NOTE 1

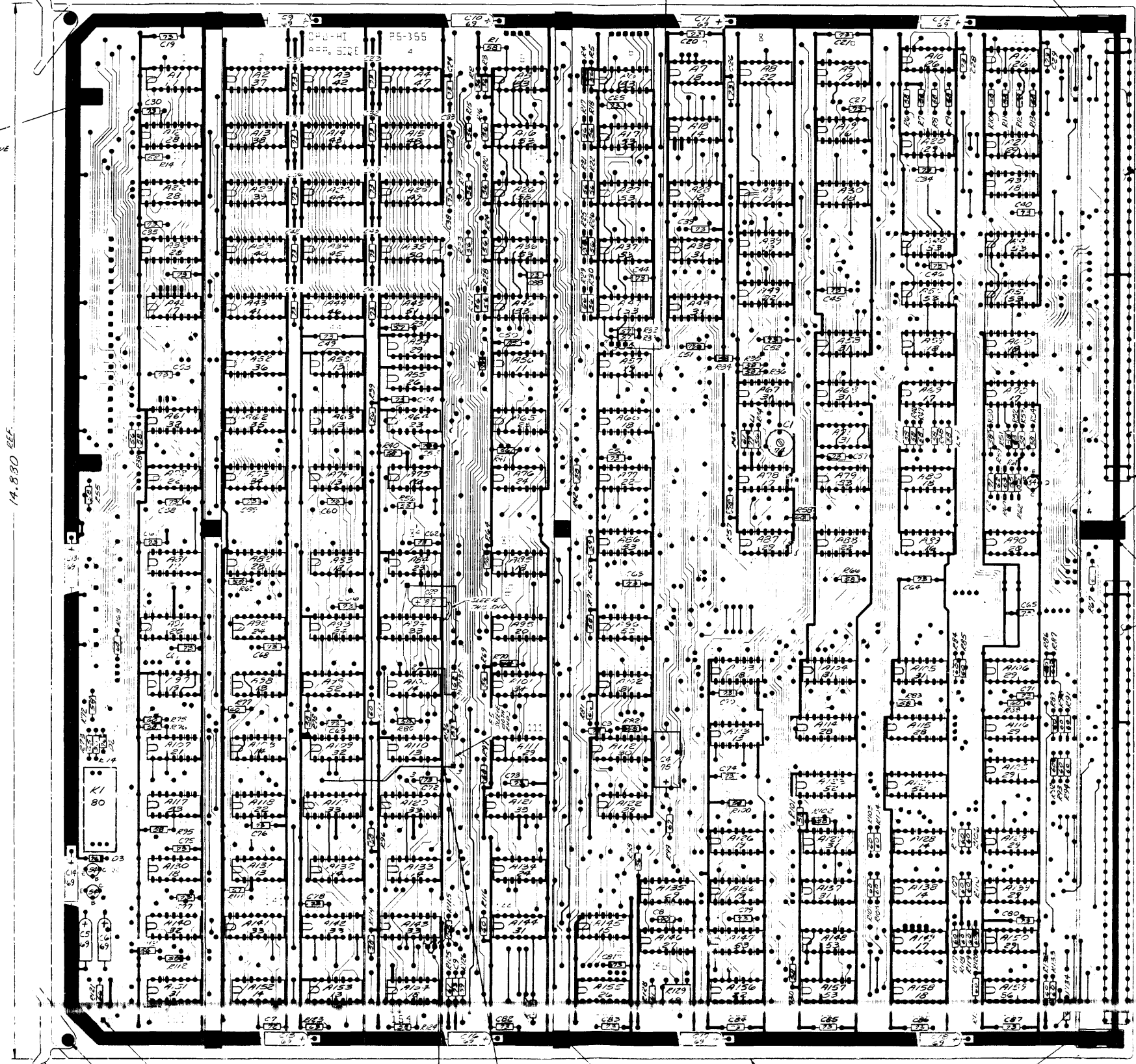

77

SEE NOTE 2

SEE NOTE 1

77

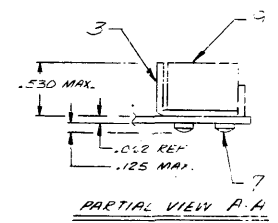

PARTIAL VIEW A-A

4 TYP 5 TYP
 7 1/2 TYP
 24 PLACES
 SHOWN

81 TYP
 2 PLACES

2.6, 8, 10

84 (3 PLACES)

SEE NOTE 1

COMPONENT	REFERENCE DESIGNATION
CAPACITOR	C1 THRU C85
RESISTOR	R1 THRU R150
INDUCTOR	L1 THRU L10

TRANSFORMER	T1 THRU T10
RELAY	K1
INDUCTOR	L1

REV.	DATE	TITLE
1	12-15-54	ASSEMBLY CPU-11 BOARD
2	1-10-55	
3	2-10-55	
4	3-10-55	
5	4-10-55	
6	5-10-55	
7	6-10-55	
8	7-10-55	
9	8-10-55	
10	9-10-55	

NOTES:
1. STIFFENER BAR (ITEM 3)
SHALL BE SOLDERED TO
GND BUD AT 2 END POINTS
AND CENTER POINT.
2. CONNECTOR PINS CLOSEST TO
EDGE OF BOARD TO BE BENT
INWARD PRIOR TO SOLDERING.
3. LAST STRAP NO. IS (11).

CUT COPPER
MOMENTOUS SIDE
(2 PLACES)

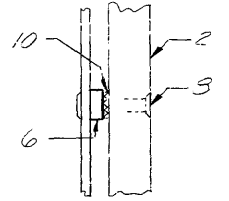

6
MOUNT IN
SOLDER 5/16"
2 PLACES

56
10 PLACES
SHOWN

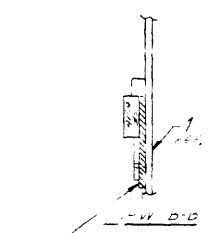

1/4" D.O.
CUT TO APPROXIMATE
SEE 4 INSTALL UNDER
ITEM 28.

15.380 REF.

SEE NOTE 1

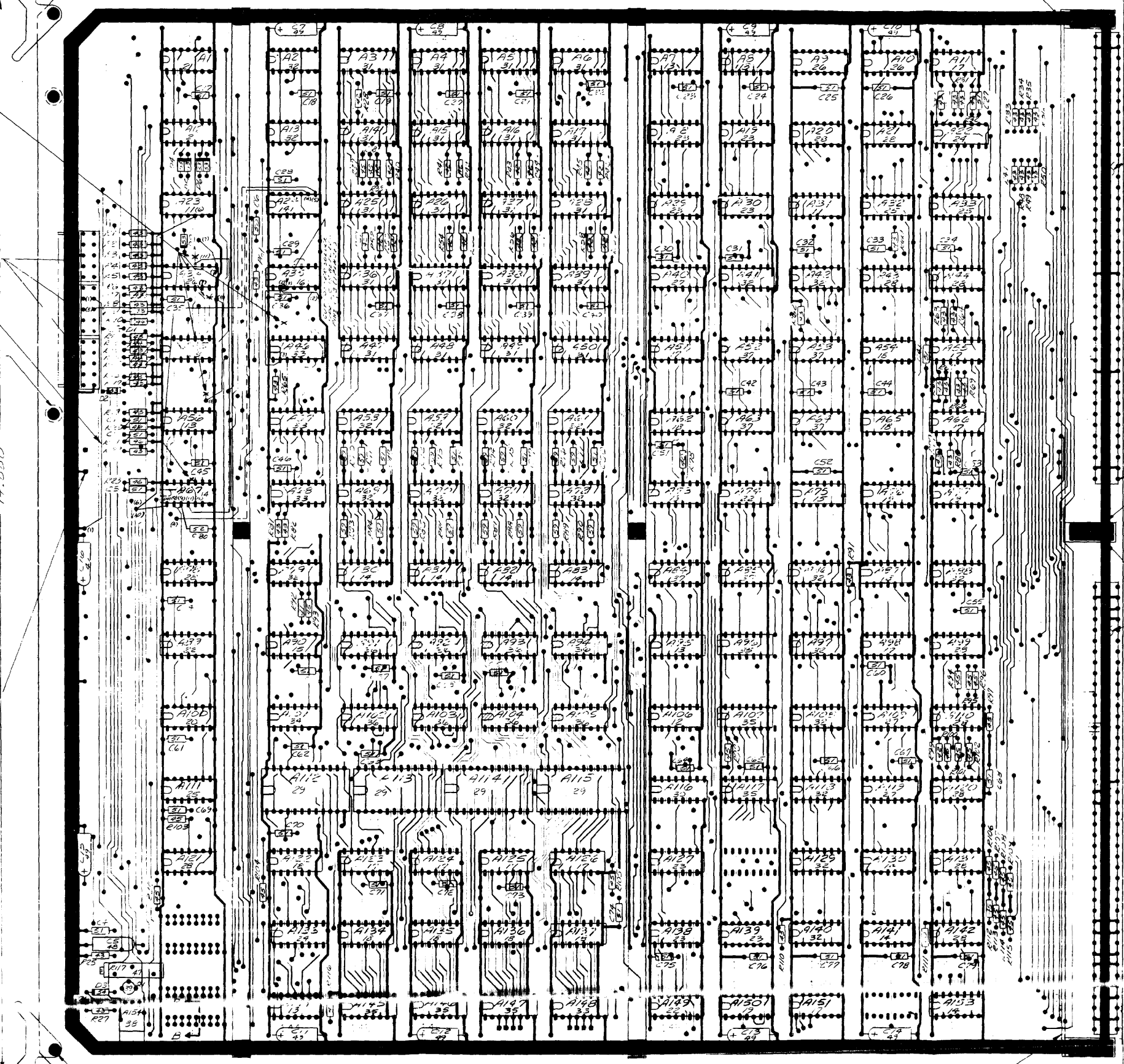

SEE NOTE 2

SEE NOTE 1

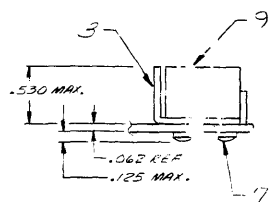

PARTIAL V-W A-A

MOD 71, CPU-LO 35-447
FORWARD RELEASED BY AUTHORITY
DATE 12-19-73
LIGORIO, J. J.
LIGORIO, J. J.
LIGORIO, J. J.

- NOTES:
1. STIFFENER BAR (ITEM 3) SHALL BE SOLDERED TO GND BUS AT 2 END POINTS AND CENTER POINT.
 2. CONNECTOR PINS CLOSEST TO EDGE OF BOARD TO BE BENT INWARD 1/16" TO SOLDERING.
 3. LAST STRAP NO. IS (2).

6
MOUNT ON SOLDER SIDE (2 PLACES)
56
(10 PLACES)

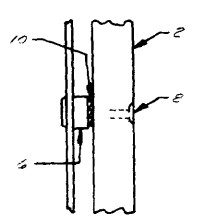

SEE FIG 3

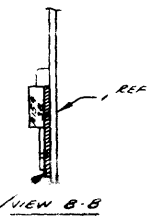

55 CUT TO APPROX. SIZE & WIDTH UNDER ITEM 38.

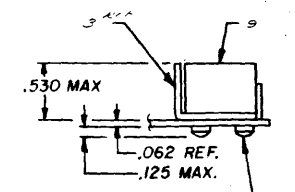
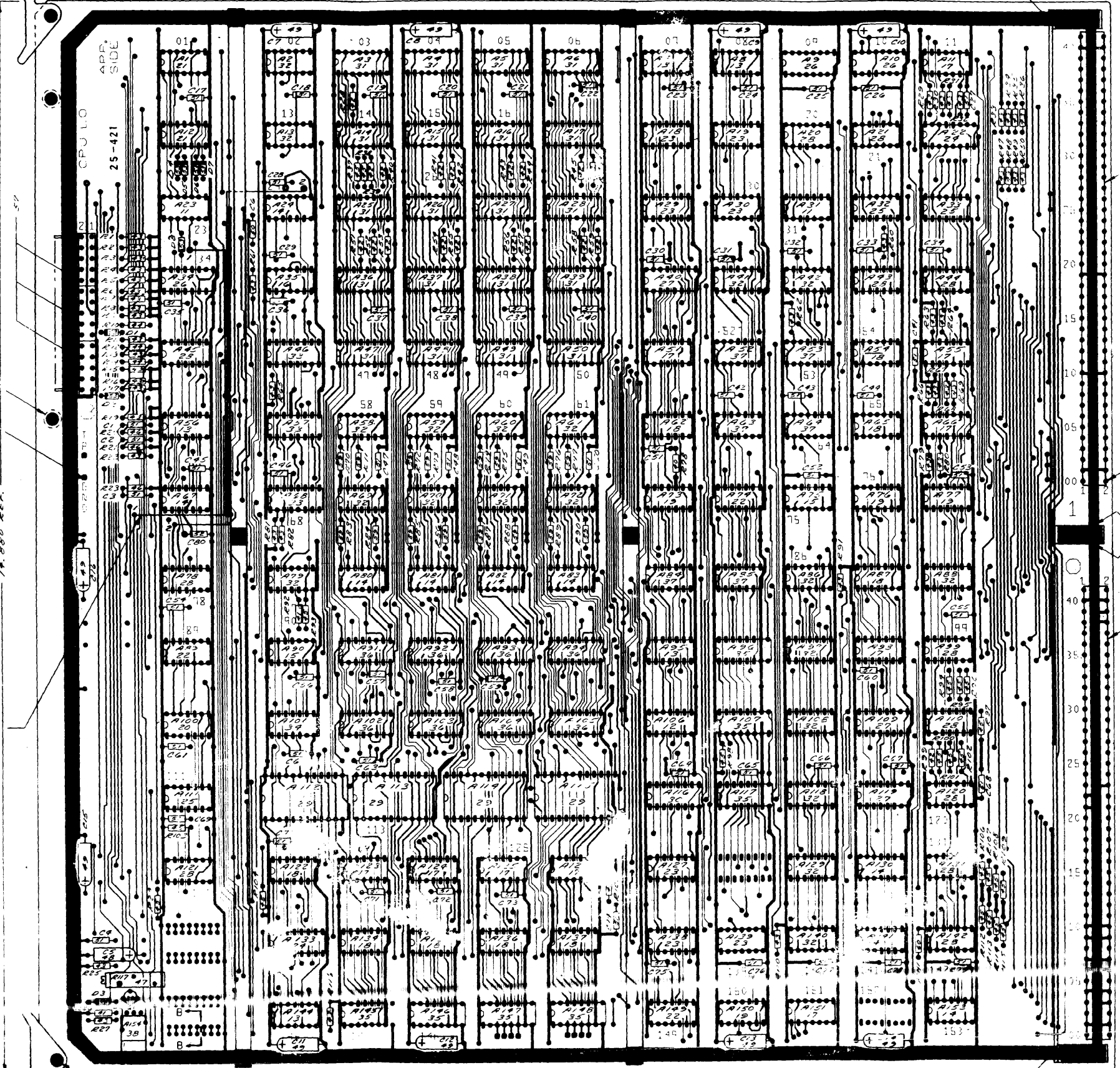

PARTIAL VIEW A-A

COMPONENT	REF DESIGNATION
CAPACITOR	C1 THRU C10
RESISTOR	R1 THRU R17
DIODE	D1 THRU D3
E.C.	A14 THRU A17
	A123 THRU A131
	A173 THRU A182
	A184 THRU A187
	A188 THRU A189

DATE	BY	CHKD	ASSEMBLY
11/17/54	H. ROSS	J. W. H.	CPU LO
11/17/54	H. ROSS	J. W. H.	MODEL 716
11/17/54	H. ROSS	J. W. H.	03087

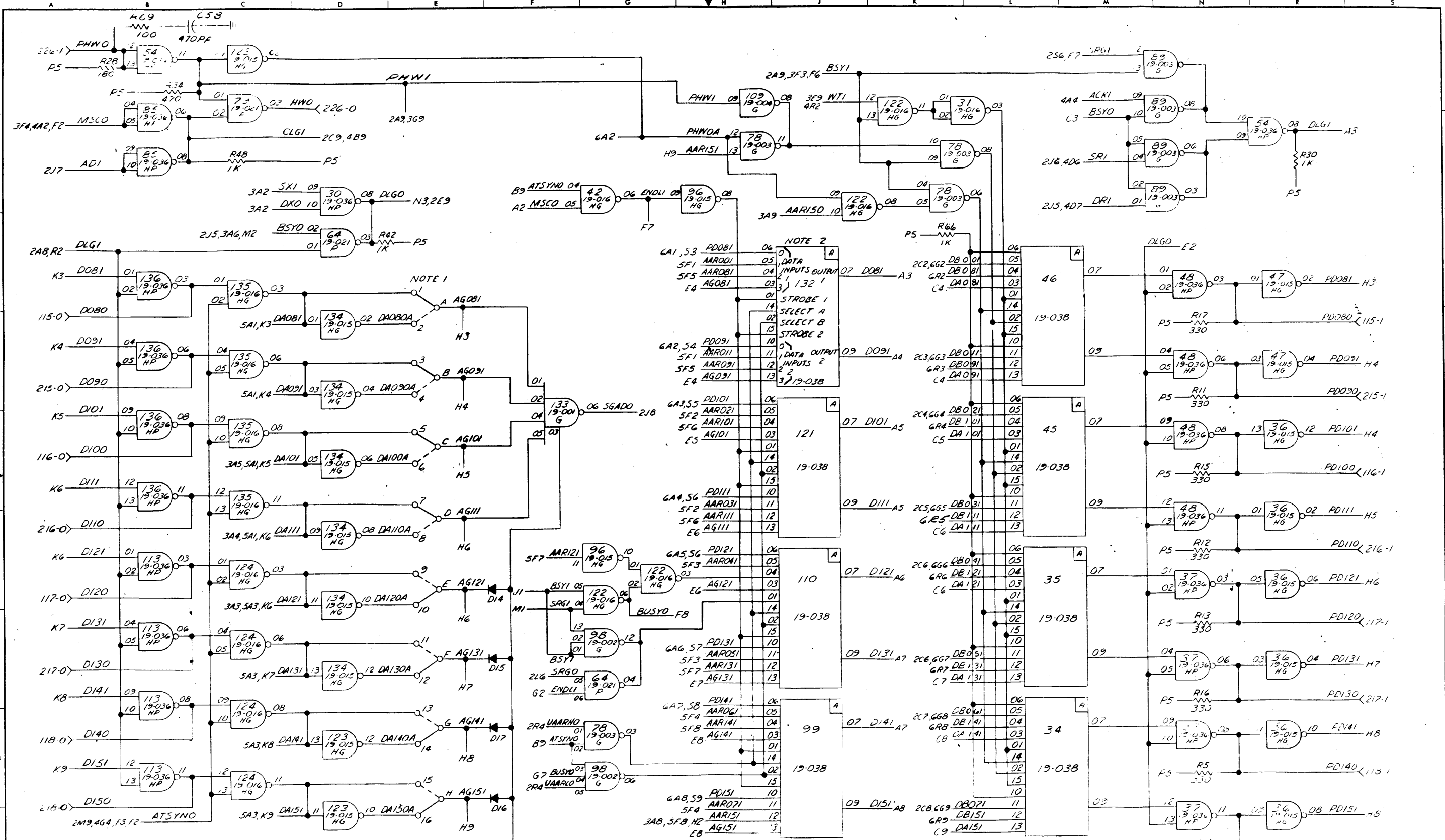

NOTES: 1. PREFERRED ADDRESS A'FO'
 ALL APPARATUS ON THIS SHEET IS LOCATED
 ON 35-341 MO. 111170K CHANNEL

NAME W. ZILGER	TITLE DRAFT	DATE 10-5-71	TITLE NS
REVISION R 100	CHK E 6 13	ENGR S 1 7 1	SELECTOR CHANNEL
DATE 10-5-71	DIR ENG	REVISION	



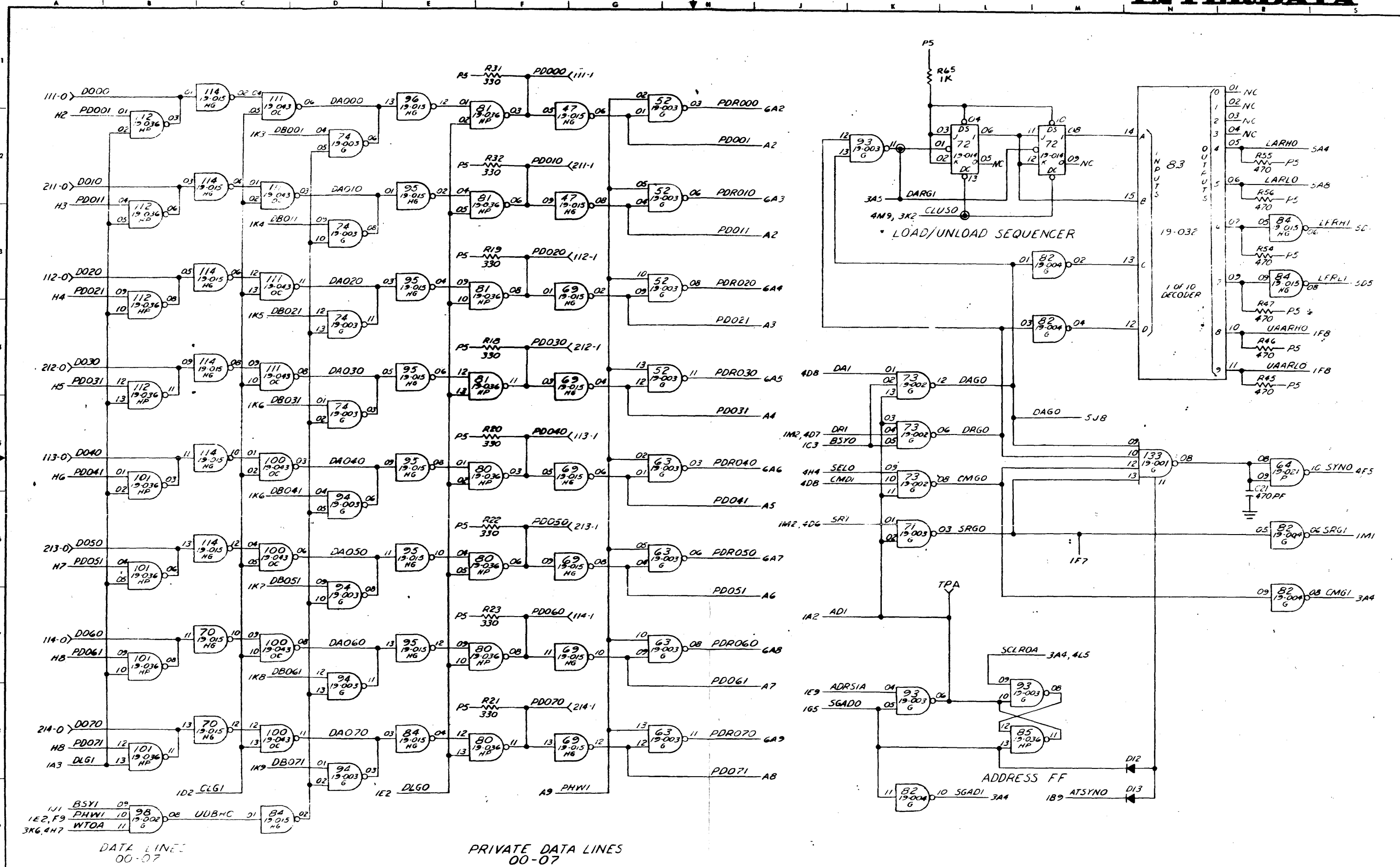

NOTES
 ALL APPARATUS ON THIS SHEET IS LOCATED
 ON 35 391 MCG SELECTOR CHANNEL

NAME	W. ZILLGER	TITLE	NS
DATE	10-5-71	CHP	
ENGR		DIP ENGR	
03075		02 232 MCI DOB 2 7	

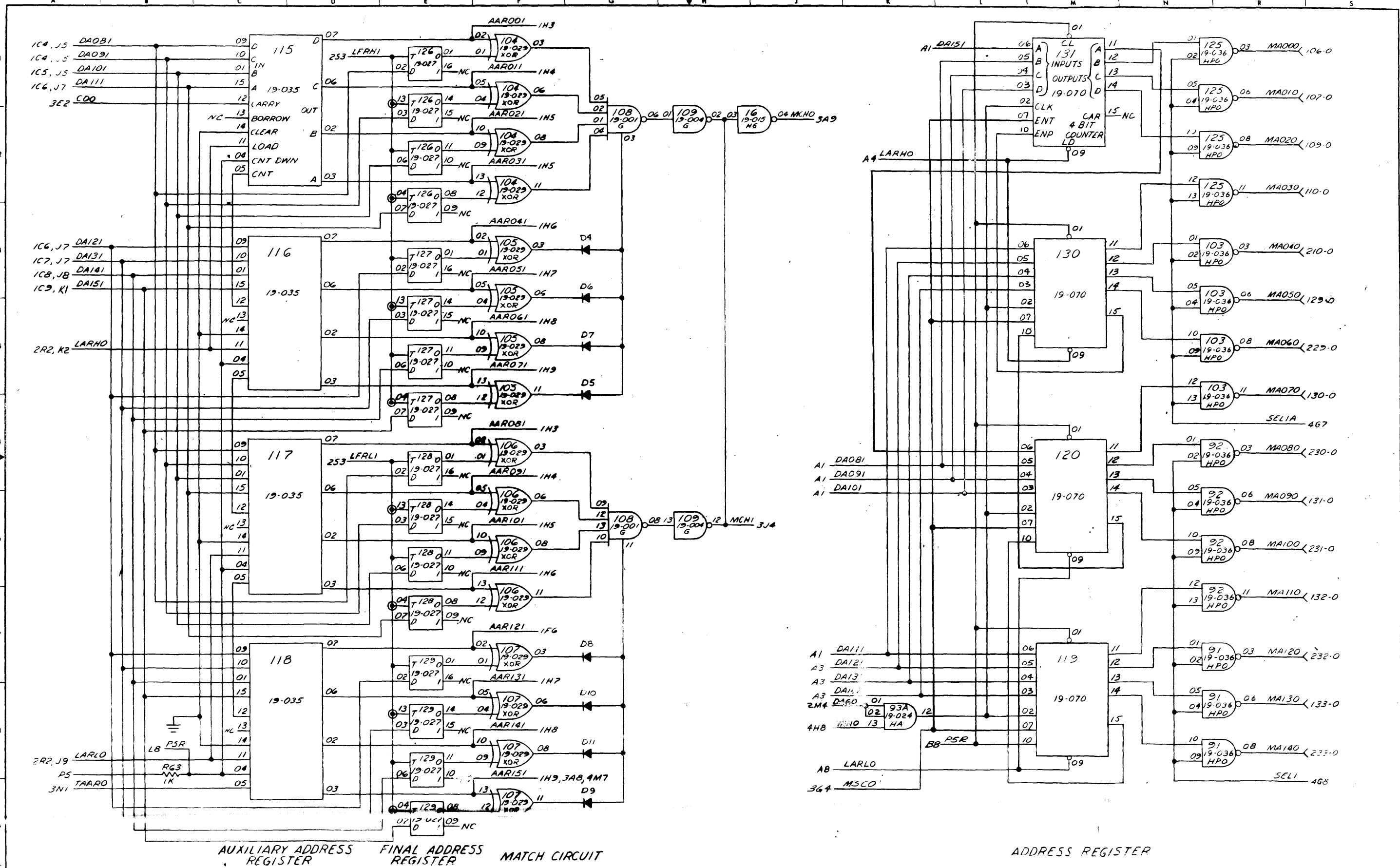

AUXILIARY ADDRESS REGISTER FINAL ADDRESS REGISTER MATCH CIRCUIT

ADDRESS REGISTER

NOTES
ALL APPARATUS ON THIS SHEET IS LOCATED ON 35-391 MO2 SELECTOR CHANNEL.

NAME W. ZILLGER	DATE 0-5-71	TITLE SELECTOR CHANNEL
NO.	03075	
REV.	02-232 MO1 DOB	5-7

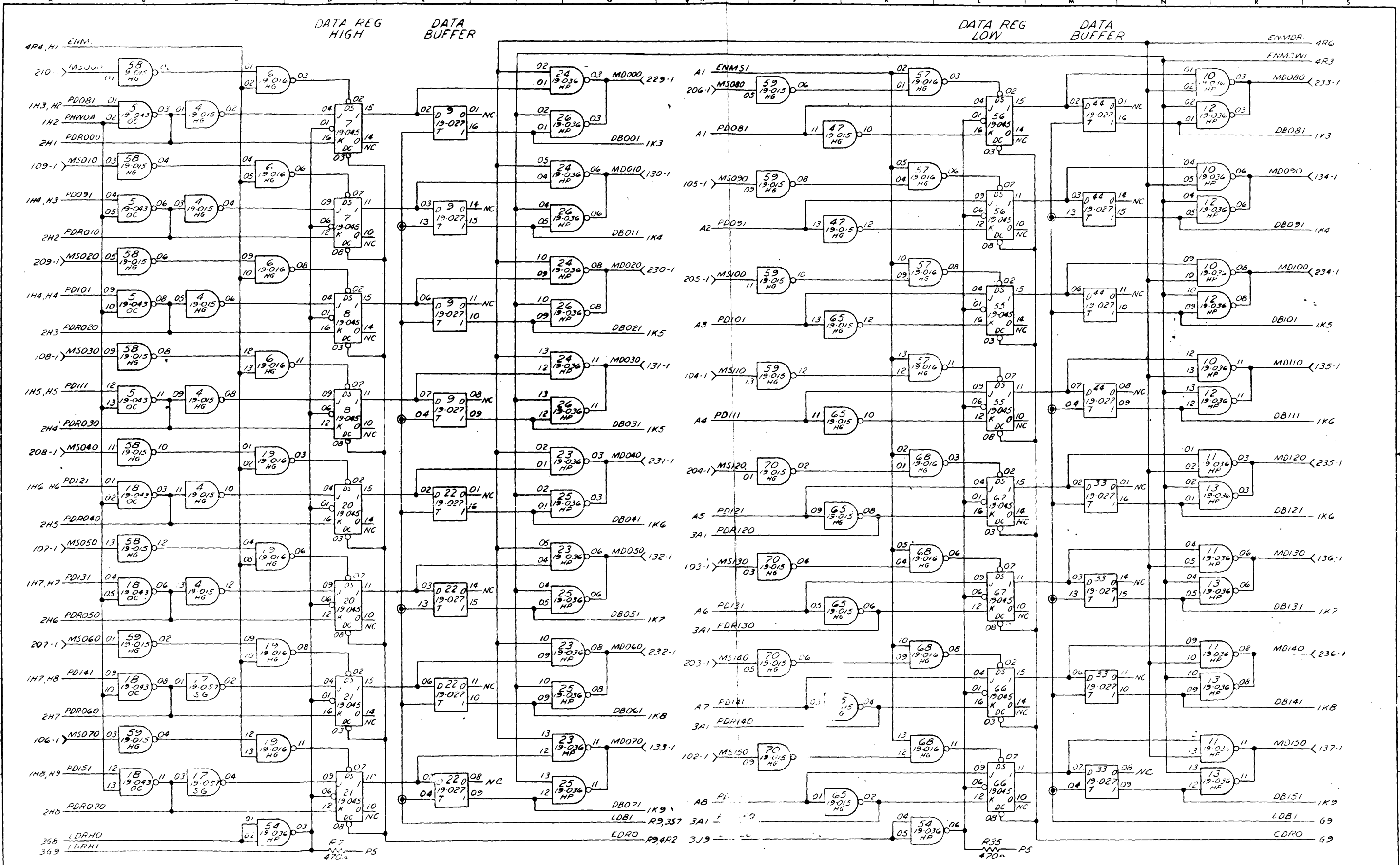

NOTES
 ALL APPARATUS ON THIS SHEET IS LOCATED
 IN 55-11112 SELECTOR CHANNEL

NAME	DATE	TITLE
H. ZILLGER	10-5-71	NS SELECTOR CHANNEL
REV		
1		03675
2		03675
3		03675
4		03675
5		03675
6		03675
7		03675
8		03675
9		03675

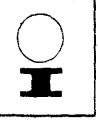

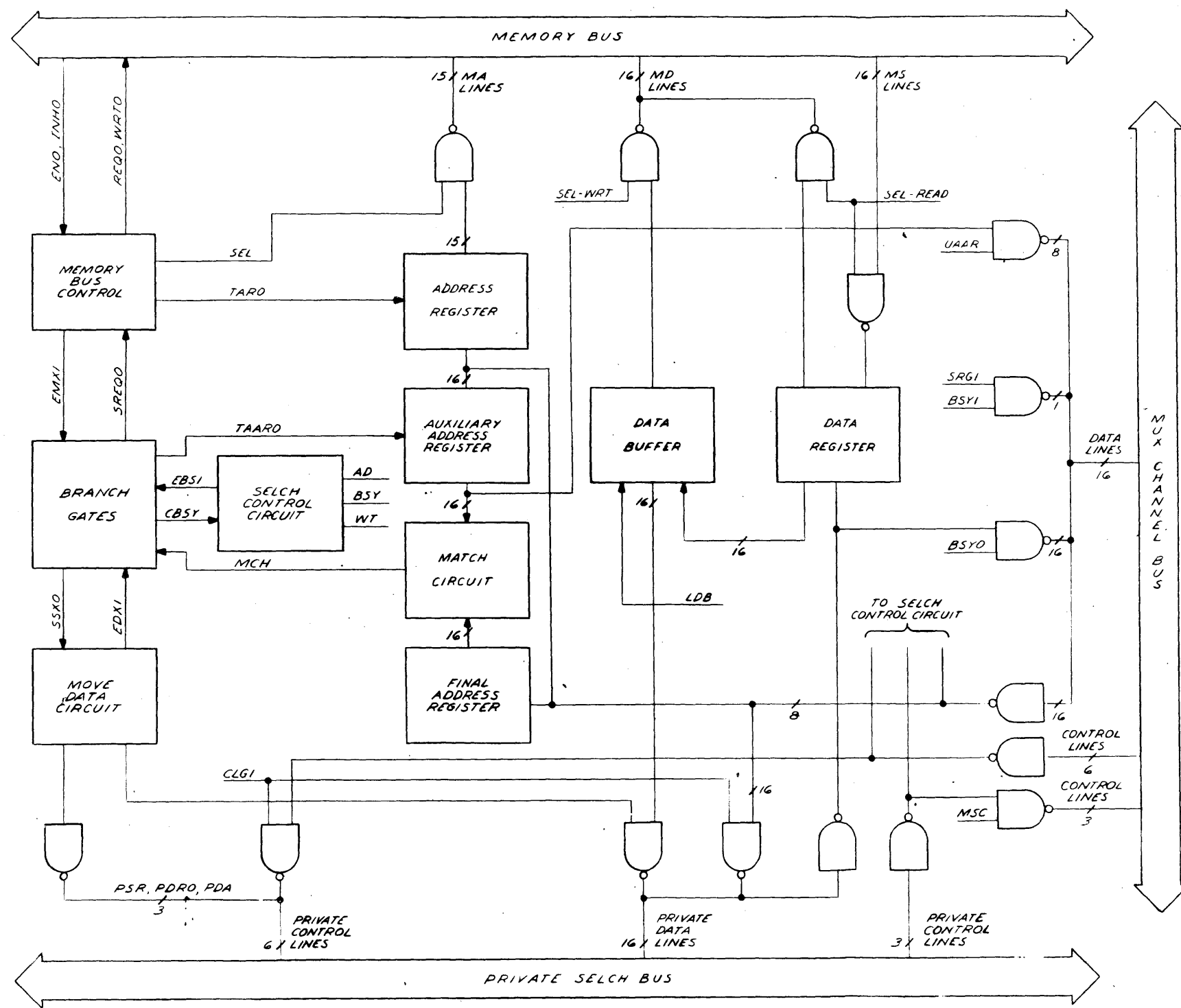

BACK PANEL PIN INDEX

MNEM	LOC.	MNEM	LOC.
ACTO	4H1	MD130	6R6
ADRSO	4B8	MD140	6R7
ATNO	4F1	MD150	6R8
CLO70	4B6	MS000	6A1
CMDO	4B3	MS010	6A2
DOO0	2A1	MS020	6A3
DO10	2A2	MS030	6A4
DO20	2A3	MS040	6A5
DO30	2A4	MS050	6A6
DO40	2A5	MS060	6A7
DO50	2A6	MS070	6A8
DO60	2A7	MS080	6H1
DO70	2A8	MS090	6H2
DO80	1A3	MS100	6H3
DO90	1A4	MS110	6H4
D100	1A5	MS120	6H5
D110	1A6	MS130	6H6
D120	1A6	MS140	6H7
D130	1A7	MS150	6H8
D140	1A8	PDRSO	4F8
D150	1A8	PATNO	4B1
DAO	4B7	PCL070	4F6
DRO	4B7	PCMDO	4F8
ENO	4H1	PDO00	2F1
HWO	1D1	PDO10	2F2
INHO	4H5	PDO20	2F3
MA000	5R1	PDO30	2F4
MA010	5R1	PDO40	2F5
MA020	5R2	PDO50	2F6
MA030	5R2	PDO60	2F7
MA040	5R3	PDO70	2F8
MA050	5R3	PDO80	1R4
MA060	5R4	PDO90	1R4
MA070	5R4	PD100	1R5
MA080	5R5	PD110	1R6
MA090	5R6	PD120	1R7
MA100	5R6	PD130	1R7
MA110	5R7	PD140	1R8
MA120	5R7	PD150	1R9
MA130	5R8	PDA0	4F7
MA140	5R8	PDR0	4F8
MD000	6G1	PHWO	1A1
MD010	6G2	PSRO	4F6
MD020	6G3	PSYNO	4B5
MD030	6G4	PSTACKO	4F2
MD040	6G5	RACKO	4B3
MD050	6G6	REOO	4B5
MD060	6G7	SCLRO	4H4
MD070	6G8	SRO	4B6
MD080	6R1	SYNO	4F5
MD090	6R2	TACKO	4H3
MD100	6R3	TACO	4R1
MD110	6R4	WRTOA	4R3
MD120	6R5		

BACK PANEL MAP

ROW		TERM NO	CONN
1	2		
PS	GND	41	
GND	GND	40	
		39	
		38	
MD150		37	
MD130	MD140	36	
MD110	M120	35	
MD090	MD100	34	
MD070	MD080	33	
MD050	MD060	32	
MD030	MD040	31	
MD010	MD020	30	
	MD000	29	
		28	
		27	
SCLRO	PHWO	26	
		25	
		24	
PSYNO	PATNO	23	
	PSTACKO	22	
PCL070	PDA0	21	
PDR0	PCMDO	20	
PSRO	PDRSO	19	
PD140	PD150	18	
PD120	PD130	17	
PD100	PD110	16	
PD080	PD090	15	
PD060	PD070	14	
PD040	PD050	13	
PD020	PD030	12	
PD000	PD010	11	
WRTOA	MS000	10	
	MS020	09	
	MS040	08	
	MS060	07	
	MS080	06	
	MS100	05	
	MS120	04	
	MS140	03	
	MS150	02	
GND	GND	01	
PS	GND	00	

TEST POINT INDEX

DESIG	MNEM	LOC.
A	ADI	2L6
B	WTI	3G5
C	SKI	3G6
D	MSCO	3G4
E	BSYO	3G3
F	ENMDRI	4S3
G	REQI	4S5
H	DXI	3G7
I	SELI	4L3
J	ENMSI	4S4
K	ENMDRI	4S6

SUPPLEMENTARY INFORMATION

PRINTED CIRCUIT BOARDS AGREEING WITH THIS SCHEMATIC MUST BE AT LEAST THE FOLLOWING REVISION

NS SELCH 35-391M02

NAME: W. ZILLGER TITLE: DATE: 3/13/71 TITLE: NS SELECTOR CHANNEL

DIR ENG: 03075 SHEET OF: 7-7

DRAWING 44 23 15041

15.380 REF.

RELEASE FOR PRODUCTION	
DATE: 11/15/54	BY: WJC
REVISIONS	
1	ADDED R72, C41
2	REMOVED R72, C41
3	ADDED STRAPS L2, L3
4	REMOVE TO REFLECT
5	ADD CHANGE
6	REMOVE STRAPS
7	ADDED STRAPS
8	ADD STRAPS
9	ADD STRAPS

48
11 JUMPERS

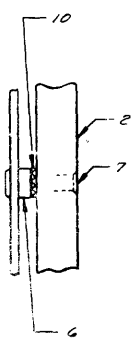

14.580 REF.

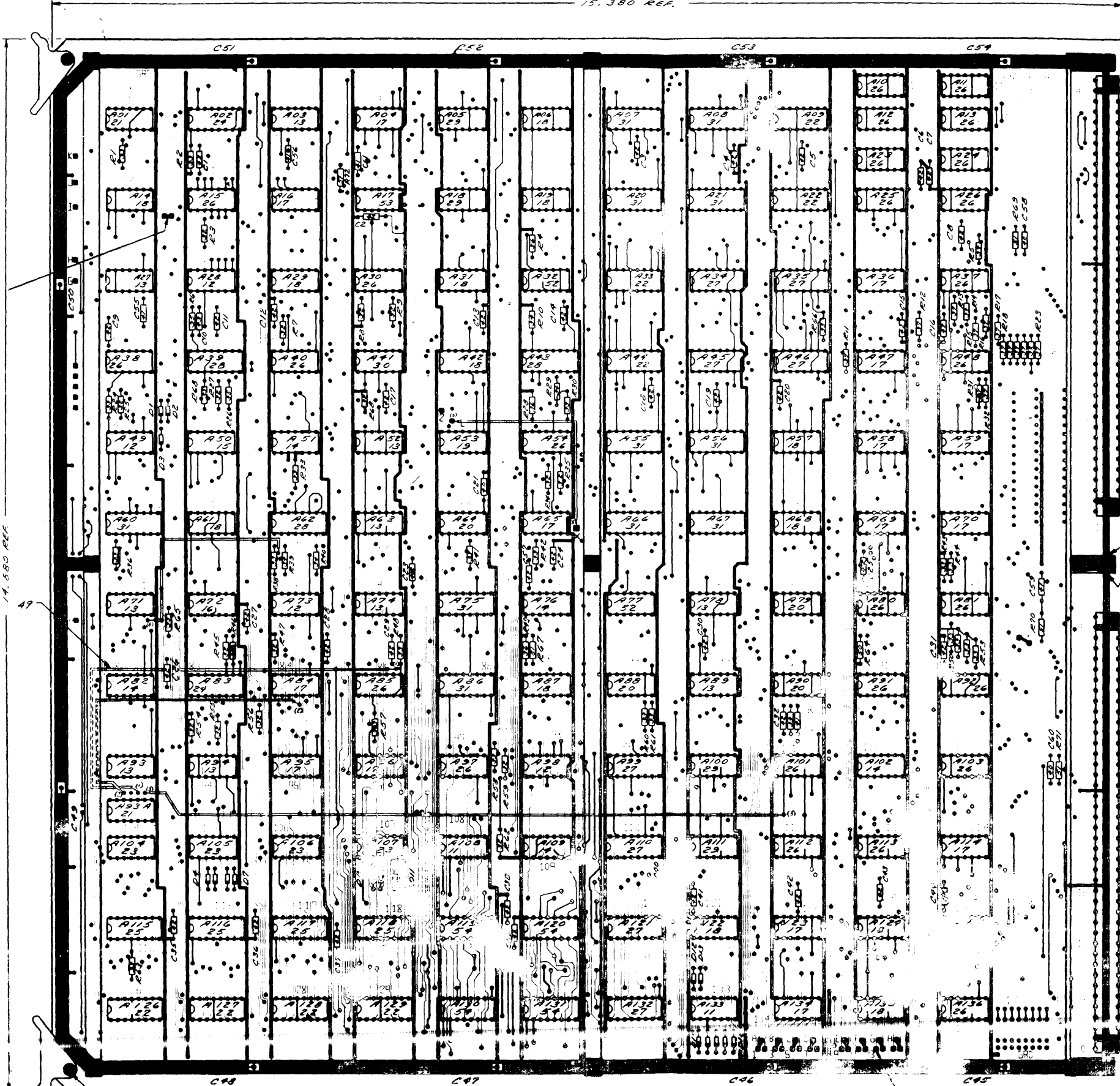

SEE NOTE 2

SEE NOTE 3

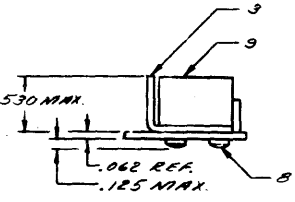

PARTIAL VIEW A-A

- NOTES:
- UNLESS OTHERWISE SPECIFIED ALL DIODES ARE ITEM #4.
 - STIFFENER BAR (ITEM 3) TO BE SOLDERED TO GROUND BUS AT 2 END POINTS AND CENTER POINT.
 - CONNECTOR PINS CLOSEST TO EDGE OF BOARD TO BE BENT INWARD PRIOR TO SOLDERING.

COMPONENT	REF. DESIGNATION
CAPACITOR	C1-21 & 23-60
RESISTOR	R1-36, 38-65 & 67-71
DIODE	D1, 2, 3, 4, 5, 6, 7, 8, 9, 10, 11, 12, 13, 14, 15, 16, 17, 18, 19, 20, 21, 22, 23, 24, 25, 26, 27, 28, 29, 30, 31, 32, 33, 34, 35, 36, 37, 38, 39, 40, 41, 42, 43, 44, 45, 46, 47, 48, 49, 50, 51, 52, 53, 54, 55, 56, 57, 58, 59, 60, 61, 62, 63, 64, 65, 66, 67, 68, 69, 70, 71, 72, 73, 74, 75, 76, 77, 78, 79, 80, 81, 82, 83, 84, 85, 86, 87, 88, 89, 90, 91, 92, 93, 94, 95, 96, 97, 98, 99, 100
	101 THRU 1136 & 934

LAST STRAP NO 13 (R)

46 INSTALL APPARATUS SIDE (42 PLACES)

SCALE 2:1	
DATE	11/15/54
BY	WJC
ASSEMBLY	N.S. SELECTOR
CHANGE	CHANGED
REVISION	1
DATE	11/15/54
BY	WJC

REVISIONS

FOR PREVIOUS REVISION SEE REV 000 VOIDED COPY IN FILE
2040/14/7-18-73/RO1

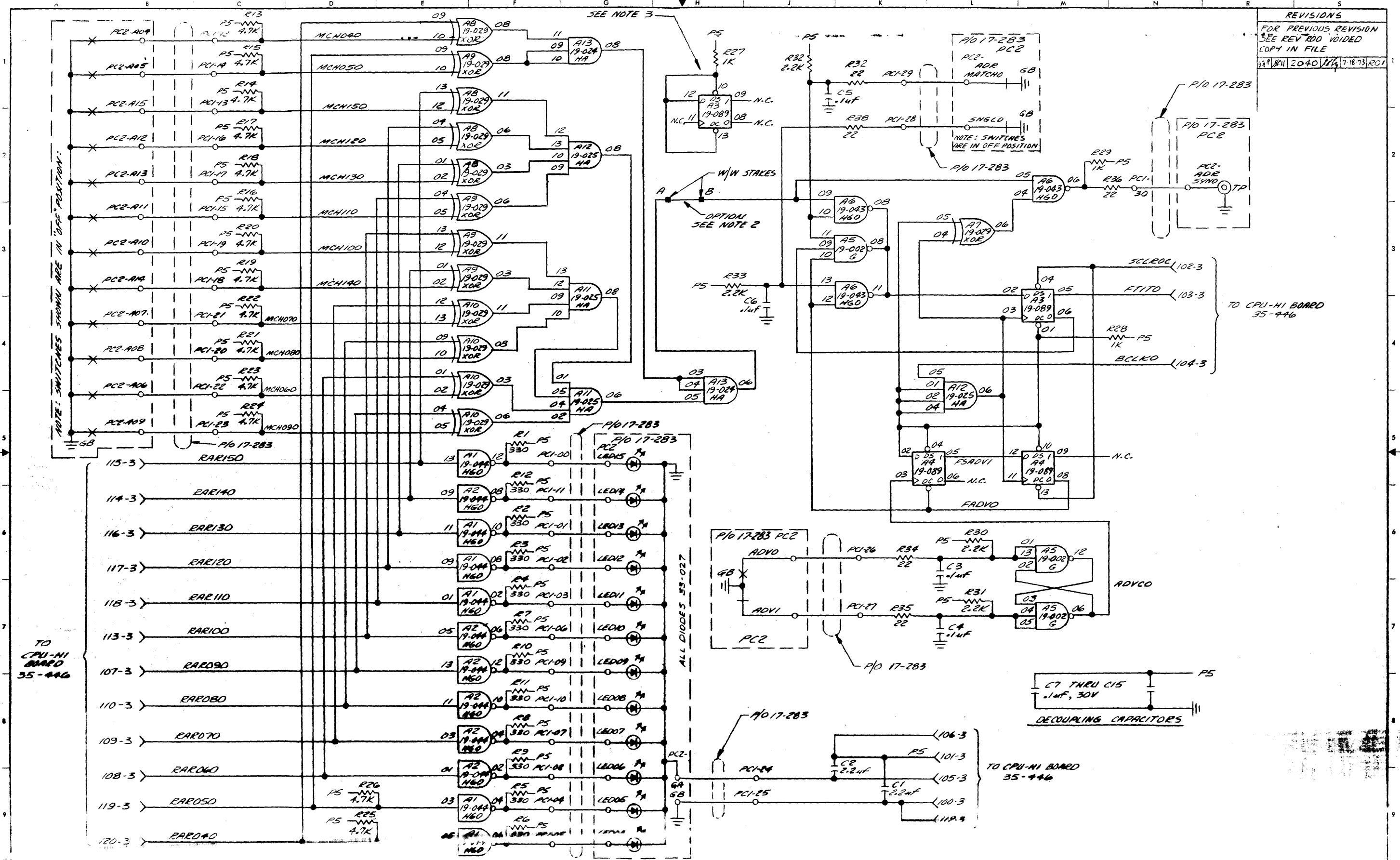

NOTES
 1. UNLESS OTHERWISE SPECIFIED ALL APPARATUS IS LOCATED ON TEST CONTROL BOARD 35-503.
 2. REFER TO 02-276 TEST AID INFO SPEC.

3. THIS FLIP FLOP-COULD BE USED AS A TEST AID.

NAME G. PERE E. CERO G. JOYCE H. ROSS J. FRANKENBERGER	TITLE TEST AID	DATE 7-17-73 7-18-73 7-19-73 7-20-73 7-21-73	TITLE FUNCTIONAL SCHEMATIC
DRAWN 7-17-73			1-1
ENGR 7-18-73			
D.C. 7-19-73			03087
DIR ENG 7-20-73			
02-276 R01/D08			



PUBLICATION COMMENT FORM

Please use this postage-paid form to make any comments, suggestions, criticisms, etc. concerning this publication.

From _____ Date _____

Title _____ Publication Title _____

Company _____ Publication Number _____

Address _____

FOLD

FOLD

Check the appropriate item.

Error (Page No. ____, Drawing No. _____)

Addition (Page No. ____, Drawing No. _____)

Other (Page No. ____, Drawing No. _____)

Explanation:

CUT ALONG LINE

FOLD

FOLD

Fold and Staple
No postage necessary if mailed in U. S. A.

STAPLE

STAPLE

FOLD

FOLD

BUSINESS REPLY MAIL
 NO POSTAGE NECESSARY IF MAILED IN U. S. A.

POSTAGE WILL BE PAID BY:

 **INTERDATA®**

2 Crescent Place, Oceanport, New Jersey 07757

FIRST CLASS
 PERMIT No. 22
 OCEANPORT, N.J.

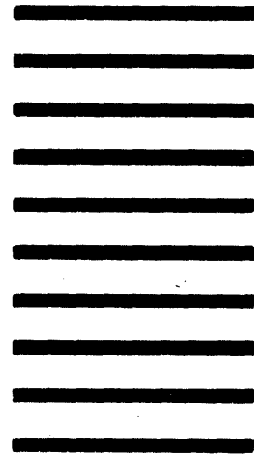

TECH PUBLICATIONS DEPT. MS15

FOLD

FOLD

STAPLE

STAPLE