

# CADR

Thomas F. Knight, Jr.  
David A. Moon  
Jack Holloway  
and Guy L. Steele, Jr.

The CADR machine, a revised version of the CONS machine, is a general-purpose, 32-bit microprogrammable processor which is the basis of the Lisp-machine system, a new computer system being developed by the Laboratory as a high-performance, economical implementation of Lisp. This paper describes the CADR processor and some of the associated hardware and low-level software.

Printed by Symbolics, Inc. under license from the Massachusetts Institute of Technology.

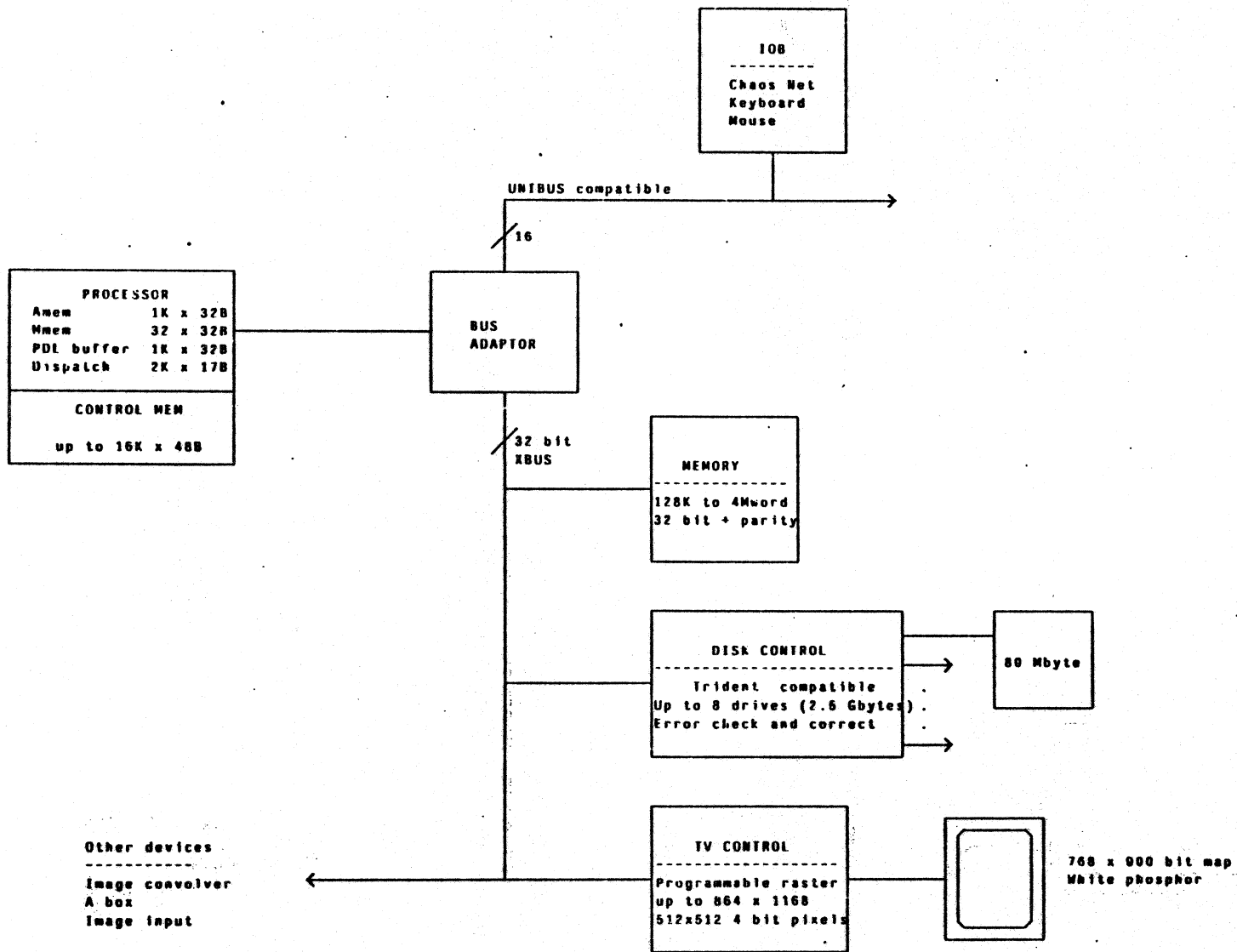

## Overview

The CADR microprocessor is a general purpose processor designed for convenient emulation of complex order codes, particularly those involving stacks and pointer manipulation. It is the central processor in the LISP machine project, where it interprets the bit-efficient 16-bit order code produced by the LISP machine compiler. (The terms "LISP machine" and "CADR machine" are sometimes confused. In this document, the CADR machine is a particular design of microprocessor, while the LISP machine is the CADR machine plus the microcode which interprets the LISP machine order code.)

The data paths of the CADR machine are 32 bits wide. Each 48-bit-wide microcode instruction specifies two 32-bit data sources from a variety of internal scratchpad registers; the two data-manipulation instructions can also specify a destination address. The internal scratchpads include a 1K pointer-addressable RAM intended for storing the top of the emulated stack, in a manner similar to a cache. Since in the LISP machine a large percentage of main memory references will be to the stack, this materially speeds up the machine.

The CADR machine has a 14-bit microprogram counter, which behaves much like that of a traditional processor, allowing up to 16K of writable microprogram memory. Also included is a 32-location microcode subroutine return stack.

Memory is accessed through a two-level virtual paging system, which maps 24-bit virtual addresses into 22-bit physical addresses.

There are four classes of micro-instructions. Each specifies two sources (A and M); the ALU and BYTE operations also specify a destination (A, or M plus functional). The A bus supplies data from the 1024-word A scratchpad memory, while the M bus supplies data from either the 32-word M scratchpad memory (a copy of the first 32 locations of the A scratchpad) or a variety of other internal registers. The four classes of microinstruction are:

- ALU**     The destination receives the result of a boolean or arithmetic operation performed on the two sources.
- BYTE**    The destination receives the result of a byte extraction, byte deposit, or selective field substitution from one source to the other. The byte so manipulated can be of any non-zero width.
- JUMP**     A transfer of control occurs, conditional on the value of any bit accessible to the M bus, or on a variety of ALU and other internal conditions such as pending interrupts and page faults.
- DISPATCH** A transfer of control occurs to a location determined by a word from the dispatch memory selected by a byte of up to seven bits extracted from the M bus.

There are several sources and destinations whose loading and use invoke special action by the microprocessor. These include the memory address and memory data

registers, whose use initiates main memory cycles.

Some of the ALU operations are conditional, depending upon the low order bit in the Q register and the sign of A source. These operations are used for multiply and divide steps.

The main features of this machine which make it suitable for interpreting the LISP machine order code are its dynamically writable microcode, its very flexible dispatching and subroutining, its excellent byte manipulation abilities, and its internal stack storage. While the design of CADR was strongly influenced by the requirements of the LISP machine design, a conscious attempt was made to avoid features that are extremely special-purpose. The goal is a machine that happens to be good at interpreting the particular order code of the LISP machine, but which is general enough to interpret others almost as well. In particular, no critical parts of the LISP machine design (such as LISP machine instruction formats) are "wired in"; thus any changes to the LISP machine design can be easily accommodated by CADR. However, there are several "efficiency hacks" in the hardware, designed to speed up certain common operations of the LISP machine microcode, which might not be useful for other microcodes. These are described in later sections of this document.

### Notational Conventions

All numbers used to describe bit positions, field widths, memory sizes, etc. are decimal. Octal is used only (and exclusively) to describe the values of fields. Bits within a word are consistently numbered from right to left, the least significant bit being bit <0>. Fields are described by the numbers of their most and least significant bits (e.g. "bits <22-10>").

Whenever a particular field value is described as "illegal", it does not mean that specifying that value will screw up the operation of the machine. It merely indicates a value which happens to have a certain function, not because it is considered directly useful, but because the internal workings of the machine may force certain selectors to that value for other reasons, and the user can select this value too even though it is not normally useful. These illegal values are described for the benefit of someone who may wish to fathom these inner workings.

A field value described as "unused" is reserved for possible design expansion and should not be used in programs. Bit fields described as "unused" should be zero in programs, for the sake of future compatibility.



Since the use of the term "micro" in referring to registers and instructions becomes redundant, its use will be dropped from here on in this part of the document. All instructions discussed are microinstructions.

The following bits are treated the same in every instruction. They will not be repeated in the individual instruction descriptions

- IR<48> = Odd parity bit
- IR<47> = Unused
- IR<46> = Statistics (see the description of the Statistics Counter)  
This can be used to count how many times specified areas of the microcode are executed, to implement microcode breakpoints, or to stop the machine at a certain "time".
- IR<45> = I LONG (1 means slow clock)
- IR<44-43> = Opcode (0 ALU, 1 JUMP, 2 DISPATCH, 3 BYTE)
- IR<42> = POPJ transfer. Causes a return from a micro subroutine, after executing one additional instruction.
- IR<11-10> = Miscellaneous Functions
  - 0 Normal
  - 1 Not used
  - 2 Write dispatch memory, if opcode is DISPATCH.
  - 3 Enable modification of the M-ROTATE field by the location counter (LC). See the description of the instruction-stream hardware.

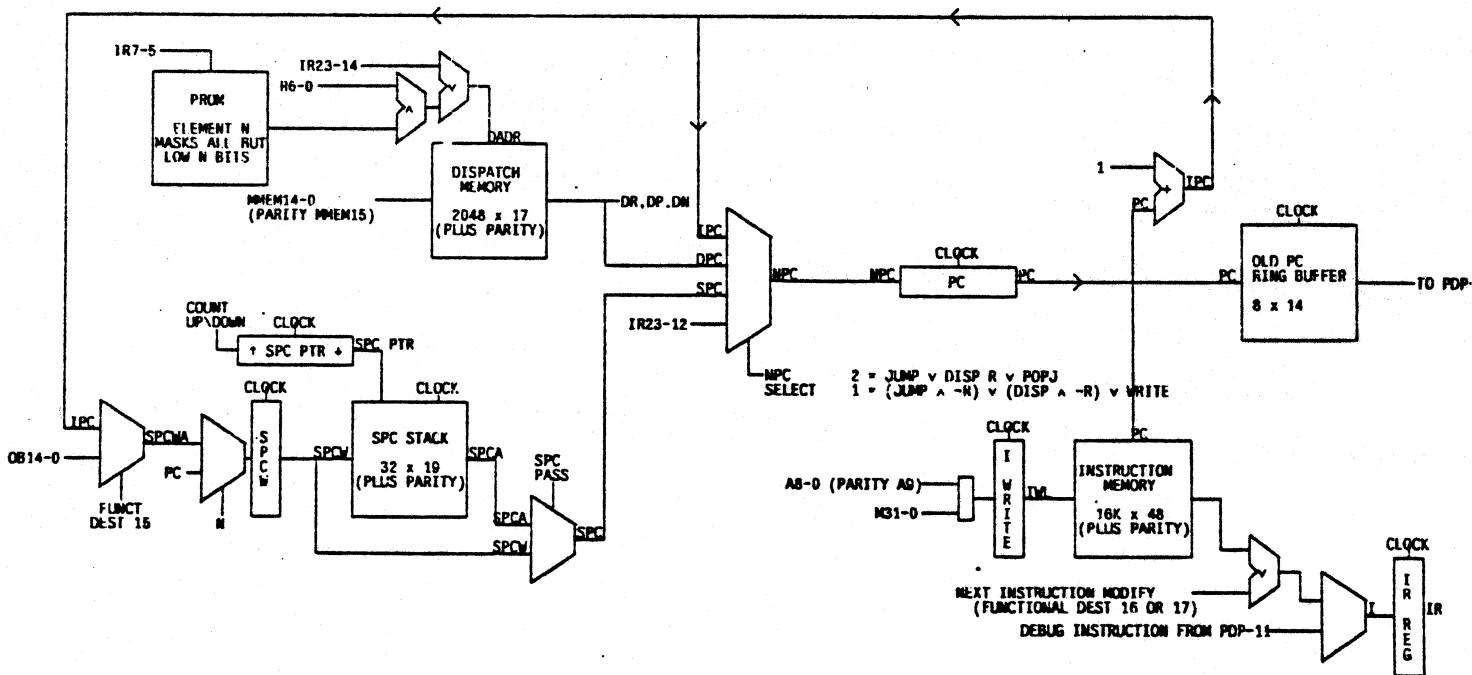

CADR Main Control Paths

## Data Paths

The data paths of the machine consist of two source busses A and M, which provide data to the ALU and byte extractor, and an output bus OB, which is selected from the ALU (optionally shifted left or right) or the output of the byte extractor, and whose data can be routed to various destinations. We first describe the specification of the source busses, which are identically specified for all instructions; then the destination specifiers which control where results are stored; and finally the two instructions for controlling the ALU and the byte extractor.

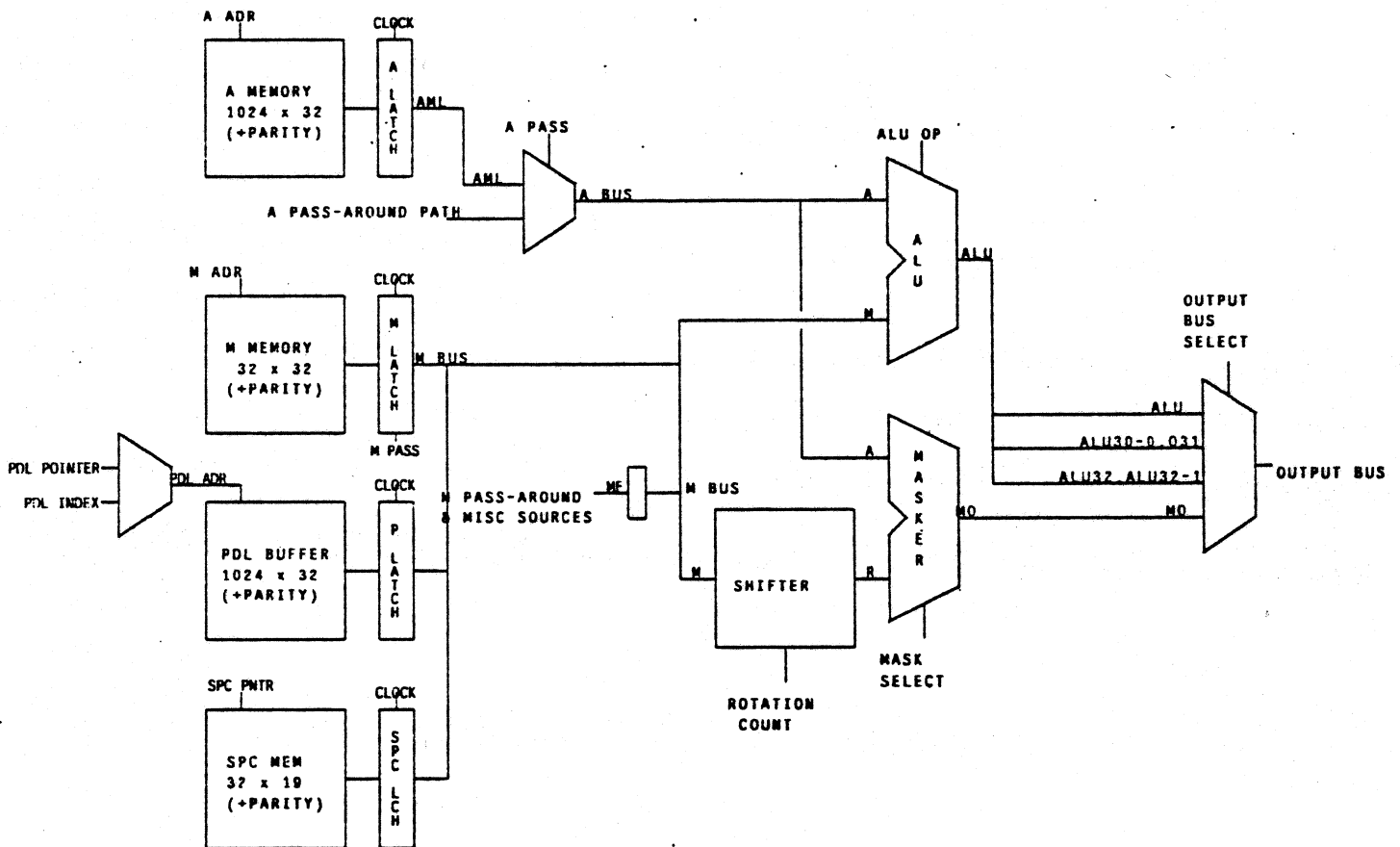

CADR A and M Busses

## Sources

All instructions specify sources in the same way. There are two source busses in the machine, the A bus and the M bus. The A bus is driven only from the A scratchpad memory of 1024 32-bit words. The M bus is driven from the M scratchpad of 32 32-bit words and a variety of other sources, including main memory data and control registers, the PC stack (for restoring the state of the processor after traps), the internal stack buffer and its pointer registers, the macrocode location counter, and the Q register. Addresses for the A and M scratchpads are taken directly from the instruction. The alternate sources of data for the M source are specified with an additional bit in the M source field.

IR<41-32> = A source address

IR<31-26> = M source address

If IR<31> = 0,

IR<30-26> = M scratchpad address

If IR<31> = 1,

IR<30-26> = M "functional" source

- 0 Dispatch constant (see below)
- 1 SPC pointer <28-24>, SPC data <18-0>
- 2 PDL pointer <9-0>
- 3 PDL index <9-0>
- 5 PDL Buffer (addressed by Index)
- 6 OPC registers (see below) <13-0>
- 7 Q register
- 10 VMA register (memory address)
- 11 MAP[MD]
- 12 MD register (memory data)
- 13 LC (location counter)
- 14 SPC pointer and data, pop
- 24 PDL buffer, addressed by Pointer, pop
- 25 PDL buffer, addressed by Pointer

Functional sources not listed above should not be used and may have side effects. Sources 15, 16, and 17 are reserved for future expansion. Source 4 is the PDL buffer, indexed by the PDL Index, and the PDL pointer is decremented, presumably a useless operation.

Programming hint: it is often convenient to reserve one A memory word and one M memory word and fill them with constant zeros, to provide a zero source for each source bus. It is also convenient to have an M memory word containing all ones. These are particularly useful for byte extraction, masking, bit setting, and bit clearing operations. The CONSLP assembler in fact assumes that A memory location 2 and M memory location 2 are sources of zeros. The UCONS microcode stores all ones in location 3.

The M scratchpad normally contains a duplicate copy of the first 32 locations of the A scratchpad. The effect is as if there were a single scratchpad memory, the first 32 locations of which were dual-ported. This makes programming more convenient, since

these locations are accessible to both sides of the ALU and shifter.

## Destinations

The 12-bit destination field in the BYTE and ALU instructions specifies where the result of the instruction is deposited. It is in one of two forms, depending upon the high-order bit. If the high-order bit is 1, then the low 10 bits are the address of an A memory location, and the remaining bit is unused. If the high order bit is 0, the low 10 bits are divided into a 5-bit "functional destination" field, and a 5-bit M scratchpad address, and both of the places specified by these fields get written into. The next-to-highest bit in the destination field is not used.

IR<25-14> = Destination

If IR<25> = 1,

IR<23-14> = A scratchpad write address

If IR<25> = 0,

IR<23-19> = Functional destination write address

0 None

1 LC (Location Counter)

2 Interrupt Control <29-26>

Bit 26 = Sequence-Break request

Bit 27 = Interrupt-Enable

Bit 28 = Bus-Reset

Bit 29 = LC Byte-mode

10 PDL (addressed by Pointer)

11 PDL (addressed by Pointer), push

12 PDL (addressed by Index)

13 PDL Index

14 PDL Pointer

15 SPC data, push

16 Next instruction modifier

("OA register"), bits <25-0>

17 Next instruction modifier

("OA register"), bits <47-26>

20 VMA register (memory address)

21 VMA register, start main memory read

22 VMA register, start main memory write

23 VMA register, write map. The map is addressed from MD and written from VMA. VMA<26>=1 writes the level 1 map from VMA<31-27>. VMA<25>=1 writes the level 2 map from VMA<23-0>.

30 MD register (memory data)

31 MD register, start main memory read

32 MD register, start main memory write

33 MD register, write map like 23

IR<18-14> = M scratchpad write address

Functional destinations not listed may have strange results. Destinations 3-7 are reserved for expansion.

**Note:** If you write into the M-memory, the machine will also write into the corresponding A-memory address. Therefore you should never write into A-memory locations 0-37; this way the first 40 (octal) locations of A-memory "map into" the M-memory.

The full details of the more complicated functional destinations are described in later sections below. The Q register is loaded by using the Q-control field of the ALU instruction, not by using a functional destination. In addition, it loads from the ALU outputs, not the output bus. This means that the left and right shift operations are ineffective for data being loaded into Q.

**Programming hint:** if a functional destination is specified, an M scratchpad location must also be specified. It is convenient to reserve one location of the M scratchpad for "garbage"; this location can be specified when it is desired to write into a functional destination but not into any other M scratchpad location. Since the CONSLP assembler defaults the M write address to zero, it is best to let location 0 be the garbage location. Location 0 of the A scratchpad will also be written and is also reserved as a garbage location.

## The ALU Instruction

The ALU operation performs most of the arithmetic in the machine. It specifies two sources of 32 bit numbers, and an operation to be performed by the ALU. The operation can be any of the 16 boolean functions on two variables, two's complement addition or subtraction, left shift, and several less useful operations. The carry into the ALU can be forced to be 0 or 1. The output of the ALU is optionally shifted one place, and then written into the specified destinations via the output bus. Additionally, the ALU instruction specifies one of four operations upon the Q register. These are do nothing, shift left, shift right, and load from the ALU outputs. An additional bit in the ALU operation field is decoded to indicate conditional operations; this is how the "multiply step" and "divide step" operations are specified. (Multiplication and division are explained in greater detail in another section.)

IR<44-43> = 0 (ALU opcode)  
 IR<41-32> = A source  
 IR<31-26> = M source  
 IR<25-14> = Destination  
 IR<13-12> = Output bus control

- 0 Byte extractor output (illegal)
- 1 ALU output
- 2 ALU output shifted right one, with the correct sign shifted in, regardless of overflow.
- 3 ALU output shifted left one, shifting in Q<31> from the right.

IR<9> = not used  
 IR<8-4> = ALU operation

- If IR<8> = 0,
  - IR<7-3> = ALU op code (see table)
- If IR<8> = 1,
  - IR<7-3> = Conditional ALU op code
    - 0 Multiply step
    - 1 Divide step
    - 5 Remainder correction
    - 11 Initial divide step

IR<2> = Carry into low end of ALU  
 IR<1-0> = Q control

- 0 Do nothing
- 1 Shift Q left, shifting in the inverse of the sign of the ALU output (ALU<31>)
- 2 Shift Q right, shifting in the low bit of the ALU output (ALU<0>)
- 3 Load Q from ALU output

ALU operation codes (from Table 1 of 74181 specifications). All arithmetic operations are two's complement. Note that the bits are permuted in such a way as to make the logical operations come out with the same opcodes as used by the Lisp BOOLE function. Names in square brackets are the CONSLP mnemonics for the operations.

IR<6-3>	<u>Boolean (IR&lt;7&gt;=1)</u>		<u>Arithmetic (IR&lt;7&gt;=0)</u>			
			<u>Carry in = 0</u>		<u>Carry in = 1</u>	
0	ZEROS	[SETZ]	-1		0	
1	$M \wedge A$	[AND]	$(M \wedge A) - 1$		$M \wedge A$	
2	$M \wedge \neg A$	[ANDCA]	$(M \wedge \neg A) - 1$		$(M \wedge \neg A)$	
3	M	[SETM]	M-1		M	
4	$\neg M \wedge A$	[ANDCM]	$M \vee \neg A$		$(M \vee \neg A) + 1$	
5	A	[SETA]	$(M \vee \neg A) + (M \wedge A)$		$(M \vee \neg A) + (M \wedge A) + 1$	
6	$M \oplus$					
A	[XOR]		M-A-1	[M-A-1]	M-A	[SUB]
7	$M \vee A$	[IOR]	$(M \vee \neg A) + M$		$(M \vee \neg A) + M + 1$	
10	$\neg A \wedge \neg M$	[ANDCB]	$M \vee A$		$(M \vee A) + 1$	
11	$M \equiv A$	[EQV]	M+A	[ADD]	M+A+1	[M+A+1]
12	$\neg A$	[SETCA]	$(M \vee A) + (M \wedge \neg A)$		$(M \vee A) + (M \wedge \neg A) + 1$	
13	$M \vee \neg A$	[ORCA]	$(M \vee A) + M$		$(M \vee A) + M + 1$	
14	$\neg M$	[SETCM]	M		M+1	[M+1]
15	$\neg M \vee A$	[ORCM]	$M + (M \wedge A)$		$M + (M \wedge A) + 1$	
16	$\neg M \vee \neg A$	[ORCB]	$M + (M \vee \neg A)$		$M + (M \vee \neg A) + 1$	
17	ONES	[SETO]	M+M	[M+M]	M+M+1	[M+M+1]



## The BYTE Instruction

The BYTE instruction specifies two sources and a destination in the same way as the ALU instruction, but the operation performed is one of selective insertion of a byte field from the M source into an equal length field of the word from the A source. The rotation of the M source is specified by the SR bit as either zero or equal to the contents of the ROTATE field. The rotation of the mask used to select the bits replaced is specified by the MR bit as either zero or equal to the contents of the ROTATE field. The length of the mask field used for replacement is specified in the LENGTH MINUS 1 field. The four states of the SR and MR bits yield the following operations:

MR=0 SR=0 Not useful (This is a subset of other modes.)

MR=0 SR=1 LOAD BYTE PDP-10 LDB instruction (except the unmasked bits are from the A source). A byte of arbitrary position from the M source is right-justified in the output.

MR=1 SR=0 SELECTIVE DEPOSIT The masked field from the M source is used to replace the same length and position byte in the word from the A source.

MR=1 SR=1 DEPOSIT BYTE PDP-10 DPB instruction. A right-justified byte from the M source is used to replace a byte of arbitrary position in the word from the A source.

The BYTE instruction automatically makes the output of the byte extractor available by forcing the output bus select code to 0 (byte extractor output).

IR<44-43> = 3 (BYTE operation)  
 IR<41-32> = A source  
 IR<31-26> = M source  
 IR<25-14> = Destination  
 IR<13> = MR = Mask Rotate (see above)  
 IR<12> = SR = Source Rotate (see above)  
 IR<9-5> = Length of byte minus 1 (0 means byte of length 1, etc.)  
 IR<4-0> = Rotation count (to the left) of mask and/or M source

The byte operation rotates the M source by 0 (if SR=0) or by the rotation count (if SR=1), producing a result called R. It also uses the MR bit, the rotation count, and the length minus 1 field to produce a selector mask (see description below). This mask is all zeros except for a contiguous section of ones denoting the selected byte. This mask is used to merge the A source with R, bit by bit, selecting a bit from A if the mask is 0 and from R if the mask is 1. This result is then written into the specified destination(s).

## Output of mask memories:

Right mask memory is indexed by 0 (MR=0) or by rotation count (MR=1).  
 Left mask memory is indexed by (the index into right mask memory) plus  
 (the length minus 1 field), mod 32.

octal index	LEFT MASK MEMORY contents	RIGHT MASK MEMORY contents
0	00000000000000000000000000000001	11111111111111111111111111111111
1	00000000000000000000000000000011	11111111111111111111111111111110
2	000000000000000000000000000000111	11111111111111111111111111111100
3	0000000000000000000000000000001111	111111111111111111111111111111000
4	00000000000000000000000000000011111	1111111111111111111111111111110000
5	000000000000000000000000000000111111	11111111111111111111111111111100000
6	0000000000000000000000000000001111111	111111111111111111111111111111000000
7	00000000000000000000000000000011111111	1111111111111111111111111111110000000
10	000000000000000000000000000000111111111	11111111111111111111111111111100000000
11	0000000000000000000000000000001111111111	111111111111111111111111111111000000000
12	00000000000000000000000000000011111111111	1111111111111111111111111111110000000000
13	000000000000000000000000000000111111111111	11111111111111111111111111111100000000000
14	0000000000000000000000000000001111111111111	111111111111111111111111111111000000000000
15	00000000000000000000000000000011111111111111	111111111111111111111111111111000000000000
16	00000000000000000000000000000011111111111111	1111111111111111111111111111110000000000000
17	000000000000000000000000000000111111111111111	11111111111111111111111111111100000000000000
20	000000000000000000000000000000111111111111111	11111111111111111111111111111100000000000000
21	000000000000000000000000000000111111111111111	11111111111111111111111111111100000000000000
22	000000000000000000000000000000111111111111111	11111111111111111111111111111100000000000000
23	000000000000000000000000000000111111111111111	11111111111111111111111111111100000000000000
24	000000000000000000000000000000111111111111111	11111111111111111111111111111100000000000000
25	000000000000000000000000000000111111111111111	11111111111111111111111111111100000000000000
26	000000000000000000000000000000111111111111111	11111111111111111111111111111100000000000000
27	000000000000000000000000000000111111111111111	11111111111111111111111111111100000000000000
30	000000000000000000000000000000111111111111111	11111111111111111111111111111100000000000000
31	000000111111111111111111111111111	11111110000000000000000000000000
32	000001111111111111111111111111111	11111100000000000000000000000000
33	000011111111111111111111111111111	11111100000000000000000000000000
34	000111111111111111111111111111111	11111100000000000000000000000000
35	001111111111111111111111111111111	11100000000000000000000000000000
36	011111111111111111111111111111111	11000000000000000000000000000000
37	111111111111111111111111111111111	10000000000000000000000000000000

After the two masks are selected, they are AND'ed together to get the final mask. This mask is all zeros, except for a field of contiguous ones defining the byte.





already in progress.) The cycle that would have executed that instruction is wasted.

The P and R bits are decoded as follows:

P=0 R=0	BRANCH	Normal program transfer.
P=1 R=0	CALL	Save the correct return address on the SPC stack, and jump to the new PC address.
P=0 R=1	RETURN	Ignore new PC; instead pop PC off the SPC stack.
P=1 R=1	FALL THROUGH	In a DISPATCH instruction, do not dispatch.
	I-MEM WRITE	In a JUMP instruction, write into the instruction memory, and do not jump.

The BRANCH transfer type is the normal program transfer, without saving a return address.

The CALL transfer type pushes the appropriate return address onto the SPC stack. This stack is 32 locations long. It is the responsibility of the programmer to avoid overflows. The return address is PC+2, or PC+1 if the N bit is also on. Actually, if the N bit is on the address of the instruction NOP'd is saved, which may not be identical to PC+1 if a transfer of control is already in progress. If the N bit is not on, 1 + the address of that instruction is saved. In the case of a dispatch, if the N bit is on and bit 25 of the instruction is on, save PC, the address of the dispatch instruction itself; this allows the dispatch to be re-executed upon return. (Actually, due to pipelining, when the above paragraph says PC it doesn't really mean PC.)

The RETURN transfer type pops a return PC from the SPC stack, ignoring the PC specified in the instruction or dispatch table.

The FALL THROUGH transfer type for dispatches allows some entries in a dispatch table to specify that the dispatch should not occur after all. The following instruction is executed (unless inhibited), followed by the one after that (unless the first following one branches and inhibits it!).

The I-MEM WRITE transfer type is the mechanism for writing instructions into the microprogram instruction memory, and is described in a later section. (The dispatch memory, unlike the instruction memory, is not written into by setting the P and R bits (after all, in a dispatch instruction these bits come from the dispatch memory!); instead, the Miscellaneous Function field is used.)

An additional bit in every instruction, including ALU and BYTE instructions, called the POPJ bit, allows specification of simultaneous execution of a RETURN transfer type along with execution of any instruction. That is, it does the same thing as if this instruction, in addition to whatever else it does, had executed a RETURN transfer type jump without the N bit on. It is the responsibility of the programmer to avoid conflicts in the use of this bit simultaneously with other types of transfers.

The POPJ bit should be used in a JUMP instruction only in conjunction with the RETURN transfer type. This will cause a RETURN operation in either case, but execution of the following instruction is conditional, controlled by the N bit and the conditional JUMP instruction. The POPJ bit, when used in a DISPATCH instruction, is

especially over-ruled by the JUMP and CALL transfer types. This allows you to RETURN normally, but jump off to other code in exceptional cases, using the same dispatch table as other dispatch instructions which do not want to return. The POPJ bit should not be used in conjunction with writing of dispatch or instruction memory, nor with the SPC pop and push functional source and destination. The machine doesn't bother to do anything reasonable in these cases.

## The DISPATCH Instruction

The dispatch instruction allows selection of any source available on the M bus [see description of M bus sources in the Data Path section], and the dispatch on any subfield of up to 7 bits from the selected word. The selected subfield is ORed with the "dispatch address" field of the instruction to produce an 11 bit address. This address is used to look up a 14 bit PC and 3 bit transfer type in the dispatch memory. The SPC-pointer-and-data-pop source will not operate reasonably in conjunction with the dispatch instruction.

- IR<44-43> = 2 (DISPATCH operation)
- IR<41-32> = Dispatch constant (also A source when writing D-MEM)
- IR<31-26> = M source
- IR<25> = Alter return address pushed on SPC by the CALL transfer type, if the N bit is set, to be the address of this instruction rather than the next instruction.
- IR<24> = Enable instruction-stream hardware (described later).
- IR<23> = Unused
- IR<22-12> = Address in dispatch memory
- IR<9-8> = Control dispatching off the map, see below.
- IR<7-5> = Length of byte (not minus 1!) from M source to dispatch on
- IR<4-0> = Rotation count (to the left) of M source

The dispatch operation takes the specified M source word and rotates it to the left as specified by the rotation count. All but the low K bits are masked out, where K is the contents of the length field. The result is OR'ed with the dispatch address, and this is used to address the 2K dispatch memory, which supplies the new PC and the R, P, and N bits.

If bits 8 and 9 of IR are not zero, the bottom bit of the dispatch address comes from the virtual memory map rather than the rotator and masker. The address inputs to the map in this case come from MD. This is primarily useful for testing pointers just fetched from main memory for validity with respect to the garbage collector's conventions. IR<8> selects bit 14 of the second level map, and IR<9> selects bit 15. Selecting both bits ORs them together.

The dispatch constant field is loaded into the DISPATCH CONSTANT register on every dispatch instruction. This register is accessible as an M source. The dispatch constant field has nothing whatsoever to do with the operation of dispatching; it is merely a convenient device for loading a completely random register while doing something else. (Uses for this feature are discussed in a later section.)

Miscellaneous function 2 inhibits the normal action of the instruction and instead loads the dispatch memory with the low order contents of the A memory scratchpad location specified in the A source. Note that the A source address is the same field as the dispatch constant field. The dispatch constant is loaded anyway, but this can be ignored. The parity bit (bit 17) is also loaded, and it is the responsibility of the

programmer to load correct (odd) parity into the memory. Normal addressing of the dispatch memory is in effect, so it is advisable to have the length field contain 0 so that the dispatch memory location to modify is uniquely specified by the dispatch address in the instruction.



## The JUMP Instruction

The JUMP instruction allows conditional branching based on any bit of any M source or on a variety of internal processor conditions, including ALU output. (While DISPATCH could also be used to test single M source bits, the use of JUMP saves dispatch memory.) The JUMP operation is also used, by means of a trick, to write into the instruction memory.

- IR<44-43> = 1 (JUMP operation)
  - IR<41-32> = A source
  - IR<31-26> = M source
  - IR<25-12> = New PC
  - IR<9> = R bit (1 means pop new PC off SPC stack)
  - IR<8> = P bit (1 means push return PC onto SPC stack)
  - IR<7> = N bit (1 means inhibit next instruction if jump successful)
  - IR<6> = If 1, invert sense of jump condition
  - IR<5> = If 0, test bit of M source; if 1, test internal condition
  - IR<4-0> = If IR<5>=0, rotation count for M source.
- If IR<5>=1, condition number:
- 0 Low bit of shifter output (illegal)
  - 1 M source < A source
  - 2 M source ≤ A source
  - 3 M source = A source
  - 4 Page fault
  - 5 Page fault or interrupt pending
  - 6 Page fault or interrupt pending or sequence break flag
  - 7 Unconditionally true

Page faults, interrupts, and sequence breaks are documented in later sections.

The jump condition is determined as follows. If IR<5>=0, then the M source is rotated left by the rotation count; the low-order bit of the result is then tested. Thus, to test the sign bit, a rotation count of 1 should be used. The jump condition is true if the low-order bit is 1. If IR<5>=1, then the specified internal condition is tested. In either case, the sense of the jump condition is inverted if IR<6>=1. In particular, this allows testing of all six arithmetic relations between the M and A sources.

If the final jump condition, possibly after inversion, is true, then the new PC field and the R, P, and N bits are used to determine the new contents of the PC. If the condition is not true, execution continues with the next instruction, modulo the POPJ bit.

If both the R and P bits are set (WRITE), then A and M sources are (conditionally!) written into the instruction memory. Bits <47-32> are taken from A source bits <15-0>; bits <31-0> are taken from M source <31-0>. Notice that this is not the same alignment of bits as is used for the "next instruction modify" functional destinations (16 and 17). The reason for the odd location of WRITE in the instruction

set is due to the way in which it operates. It causes the same operations as the CALL transfer type, resulting in the the old PC plus 1 or 2 being saved on the SPC stack and the PC register being loaded with the address to be modified. Then, when the instruction memory would normally be fetching the instruction to be executed from that location, a write pulse is generated, causing the saved data from the A and M sources to be written into the instruction memory. Meanwhile, the machine simulates a RETURN transfer instruction, causing the SPC stack to be popped back into the PC and instruction execution to proceed from where it left off. Note that this instruction requires use of a word on the SPC stack and requires an extra cycle. It is highly recommended that the N bit also be on in the JUMP instruction, since the processor will be executing a RETURN transfer type unconditionally during what should be the execution of the instruction following the write. If, however, this does not conflict with other things that this following instruction specifies, then the following instruction may be executed. Care is required.

## Program Modification

A novel technique is used for variabilizing fields in the program instruction. Two of the "functional destinations" of the output bus are (conceptual) registers (sometimes collectively referred to as the OA register), whose contents get OR'ed with the next instruction executed. Combined with the shifter/masker ability to move any contiguous set of bits into an arbitrary field, this feature provides, for example, variable rotation counts and the ability to use program determined addresses of registers; for example, it can be used to index into the A scratchpad memory.

Functional destination 16 (OA-REG-LOW), when written into, effectively OR's bits <25-0> into bits <25-0> of the next instruction; functional destination 17 (OA-REG-HIGH) effectively OR's bits <21-0> into bits <47-26> of the next instruction. The place between bits <26> and <25> is a natural dividing line for all classes of instructions. Note that only one half of a particular instruction can be modified, since it is impossible to write into both functional destinations simultaneously.

When this feature is used, parity checking is disabled for the word fetched from the instruction memory, since the OA "register" is OR'ed into the output of the memory before parity is checked.

This feature is particularly useful for supplying the address of a location of instruction memory or dispatch memory to be written into, for specifying variable addresses in the A and M memories, and for operations on bytes of variable length or position. Examples of these are detailed in a later section.

## Clocks

The CADR processor uses only one clock signal. This clock loads output data into the designated registers, and a new PC and instruction are also loaded. The only events which do not take place synchronous with the clock are the control signals for the A, M, and PDL scratchpads and the SPC stack. For these devices, a two stage cycle is performed. During the first phase, the source addresses of the respective devices are gated into the address inputs. After the output data has settled, the outputs of these devices are latched. Then, the address is changed to that specified as the write location from the previous instruction. After the address has settled, a write pulse is generated for the scratchpad memory to perform the write. Pass-around paths are provided (invisibly to the programmer) for the A and M memories, which notice and correct read references to a location which was written into on the previous cycle but has not yet actually been written into the scratchpad. No such pass-around path is provided for the PDL memory, because on any cycle in which the PDL memory is written into, the M scratchpad must also be written into, and so the next instruction can refer to that M scratchpad location, thereby using the M pass-around path. The SPC stack has a pass-around path when used by the RETURN transfer type, but does not have a pass-around path when used as an M source. The RETURN pass-around path makes it possible to have a subroutine only two instructions long. It would take extra hardware to provide the missing pass-around paths, and examination of actual microprograms showed that they would be very rarely used.

The clock cycle is of variable length. The duration of the first half of the cycle (the "read phase") is controlled by both the I LONG bit of the instruction (IR<45>) and by two "speed" bits from the diagnostic interface. The duration of the second half (the "write phase") is normally fixed. This clock serves as both the processor clock and a clock for the bus interface, memory, and external devices.

The clock can be stopped at the end of either phase, for several reasons. Usually the clock stops at the end of the read phase, referred to as "wait". This leaves the clock in the inactive high state, and leaves the latches on the memories open. The clock can wait because the machine was commanded to halt by the diagnostic interface, because a single-step commanded by the diagnostic interface has completed, because of an error such as a parity error, because of the statistics counter overflowing, or because of a memory-wait condition. This latter condition happens if a main memory cycle is initiated while a previous cycle is still in progress, or if the program calls for the result of a main memory read before the bus controller has granted the bus access needed to perform that read cycle. During a clock wait, the processor clock stops, but the clock to the rest of the system (the bus interface and XBUS devices), continues to run, allowing them to operate. When the processor finishes waiting the processor clock starts up in synchrony with the external clock.

The clock can also stop at the end of the write phase, referred to as "hang". This is used only during memory reads. If the processor calls for the result of a read which is in progress but has not yet completed, it hangs until the data has arrived from memory and sufficient time has passed for the data to flow through the data paths and appear on the output bus. This is also sufficient time for the parity of the data to be checked. In the case of a hang, both clocks stop, which allows them to restart synchronously without any extra delay. In this way, the speed of the processor is adjusted

to exactly match the speed of the memory.

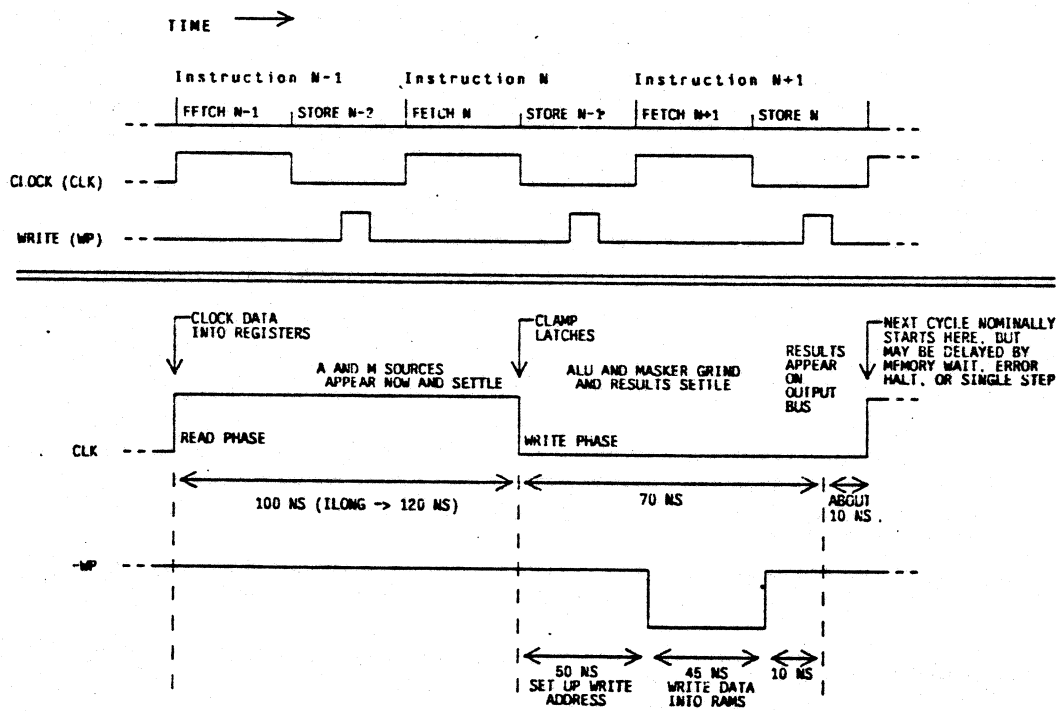

CADR Cycle Timing

## Accessing Memory

Access to main memory is accomplished through use of several functional sources and destinations. These perform three functions; first, they allow access to two registers, VMA (virtual memory address) and MD (memory data). Secondly, they can initiate memory operations. Thirdly, they can wait for a memory operation to be completed. Actually, this facility is not just for accessing main memory; it is used to access any device on the Xbus or the Unibus, which includes not only memory but peripheral equipment. For simplicity the term "memory" will be used, however.

There are eight functional destinations associated with the memory system. Four of these load data into the VMA, the other four load data into the MD. Each group of four consists of one with no other side effects, one which starts a read cycle, one which starts a write cycle, and one which writes into the virtual address map.

In a memory read operation, data from memory is placed in the MD register when it arrives, and can then be picked up by the program (using a functional source). In a memory write operation, the program places the data to be written into the MD register (by using a functional destination), whence it is passed to the memory.

The VMA register contains the virtual address of the location to be referenced. This is 24 bits long; the high 8 bits of the register exist but are ignored by the hardware. The VMA contains a "virtual" address; before being sent to the memory it is passed through the "map", which produces a 22 bit physical address, controls whether permission for the read or write operation requested is allowed, and remembers 8 bits which the software (microcode) can use for its own purposes.

Except when starting a memory cycle, the address to be mapped comes from bits <23-0> of the MD register, rather than the VMA register. The reason for this is to simplify the use of the map for checking what "space" a pointer being read from or written into memory points at, a frequently-needed operation in the Lisp machine garbage-collection algorithm.

The map consists of two scratchpad memories. The First Level Map contains 2048 5-bit locations, and is addressed by bits <23-13> of the VMA or MD. The Second Level map contains 1024 24-bit locations, and is addressed by the concatenation of the output from the First Level Map and bits <12-8> of the VMA or MD. The virtual address space consists of 2048 blocks, each containing 32 pages. Each page contains 256 words (of 32 bits, of course). Each block of virtual address space has a corresponding location in the First Level Map. Locations in the Second Level Map are not permanently allocated to particular addresses; instead, the First Level Map location for a block of virtual addresses indicates where in the Second Level Map those addresses are currently described. The Second Level Map contains sufficient space to describe 32 blocks, so at any given time most blocks must be described as "no information available." This done by reserving the last 32 locations in the Second Level Map for this purpose and filling them with "no information available" page descriptors; most First Level Map locations will point here.

The output of the Second Level Map consists of:

- MAP<23> = access permission
- MAP<22> = write permission
- MAP<21-14> = available to software. Note that bits 15 and 14 can be tested by the DISPATCH instruction.
- MAP<13-0> = physical page number

The physical address sent to memory is the concatenation of the physical page number and bits 7-0 of the VMA.

The two maps can be read by putting an appropriate address in the MD, and reading the functional source MEMORY-MAP-DATA (11):

- MAP<31> = 1 if the most recent memory cycle was not performed because it was an attempt to write without write permission, i.e. a 1 in bit 22 of the second level map.
- MAP<30> = 1 if the most recent memory cycle was not performed because there was no access permission, i.e. a 1 in bit 23 of the second level map. MAP<30> is 0 if no access fault exists, although a write fault may exist. Note that bits <31-30> apply to the last attempted memory cycle, and have nothing to do with the map locations addressed by the contents of MD.
- MAP<29> = 0 always.
- MAP<28-24> = First Level Map
- MAP<23-0> = Second Level Map

The maps can be written by using one of the functional destinations VMA-WRITE-MAP (23), MEMORY-DATA-WRITE-MAP (33). The MD supplies the address of the map location to be written, and the VMA supplies the data to be written, and tells which level of the map is being written. One register must be set up in a previous instruction, the other is written via the functional destination, and the actual writing into the map happens on the following cycle. There is no pass-around path and no latch for the map, so the following instruction must not use it.

The first level map is written from bits <31-27> of the VMA, if VMA<26> is a 1. (These are not the same bits as it reads into when using the MEMORY-MAP-DATA functional source.) The second level map is written from VMA<23-0>, if VMA<25> is a 1. Note that when writing the second level map the first level map supplies part of the address, and must have been written previously. Therefore it is not useful to write both at the same time, although it is possible to set both bits to 1.

Main memory operations are initiated by using one of the functional destinations VMA-START-READ (21), VMA-START-WRITE (22), and MEMORY-DATA-START-WRITE (32). There is also MEMORY-DATA-START-READ (31), but it is probably useless. In the case of a write, the VMA supplies the address and the MD supplies the data, so one register must be set up in advance and the other is set up by the functional destination that starts the operation. A main memory read can also be started by the

macro instruction-stream hardware, described later.

The register named (VMA or MD) is loaded with the result of the instruction (from the Output Bus) at the end of the cycle during which that instruction is executed. During the following cycle, the map is read. The instruction executed during this cycle should be a JUMP instruction which checks for a page fault condition. At the end of this cycle, if no page fault occurs, the memory operation begins. The processor continues executing while the memory operation happens, but if any operation which conflicts with the memory being busy is attempted, the machine waits or hangs until the memory operation has been completed. Such references include asking for the results of a read cycle by using the MEMORY-DATA (12) functional source, using any functional destination that refers to the VMA, MD, or MAP, or attempting to start a read cycle via the instruction-stream hardware.

The presence or absence of a page fault is remembered until the next time a memory cycle is started, so it is not strictly necessary to check for page fault immediately after starting a cycle, but is good practice.

The MEMORY-DATA-START-WRITE destination is useful for doing the second half of a read-followed-by-write operation, since the correct value is still in the VMA. Note that it is still necessary to check for a page fault after starting the write, since you may have read permission but not write permission.

There is a feature by which main memory parity errors can be trapped to the microcode. A bit in the diagnostic interface controls whether or not this is enabled. When the MEMORY-DATA functional source is used, and the last thing to be loaded into the MD was data from memory which had even parity, a main memory parity error has occurred. If trapping is enabled, the current instruction is NOPed and a CALL transfer to location 0 is forced. The following instruction is also NOPed. The trap routine must use the OPC registers to determine just where to return to if it plans to return, since if a transfer operation was in progress the address pushed on the SPC stack by the trap may have nothing to do with the address of the instruction which caused the trap. This is also true of the error-handler for microcode-detected programming errors. If a main memory parity error occurs, and trapping is not enabled, the machine halts if error-halting is enabled, just as it does in response to a parity error in an internal memory.

When using semiconductor main memory, which has single-bit error correction, a parity error trap indicates that an uncorrectable multiple-bit error occurred. Single-bit errors are corrected automatically by the hardware, and cause an interrupt so that the processor may, at its leisure, log the error and attempt to rewrite the contents of the bad location.



## The Instruction-Stream Feature

The CADR processor contains a small amount of hardware to aid in the interpretation of an instruction stream which comes in units smaller than the CADR word size. For example, the Lisp-machine macrocompiled instruction set uses 16-bit units. The hardware speeds up both fetching and decoding of instructions by relieving the microcode of some routine bookkeeping.

Both 8-bit (byte) and 16-bit (halfword) instructions are supported, depending on a mode bit (bit 29 of the "Interrupt Control" register, functional destination 2.) The hardware decides when it is time to fetch a new main-memory word, containing the next 2 or 4 units of the instruction stream, and alters the flow of microprogram control. The hardware provides a feature by which the rotator control can be made to select the current unit of the instruction stream; this is used when dispatching on the instruction being interpreted, and when extracting fields of the instruction via the BYTE microinstruction.

There is a 26-bit register called the Location Counter (LC), which can be read by functional source 13 and written by functional destination 1. It always contains the address of the next instruction stream unit, in terms of 8-bit bytes. In halfword mode LC<0> is forced to zero. The LC is capable of counting by 1 or 2 (depending on byte vs. halfword mode) and has a special connection to the VMA; the VMA is loaded from the LC, divided by 4, when an instruction-fetch occurs.

The high 6 bits of functional source 13 are not part of the LC per se, but contain various associated status, as follows:

- 31 Need Fetch. This is 1 if the next time the instruction stream is advanced, a new word will be fetched from main memory. This is a function of the low 2 bits of LC, of byte mode, and of whether the LC has been written into since an instruction word was last fetched from main memory.
- 30 not used, zero.
- 29 LC Byte Mode. 1 if the instruction stream is in 8-bit units, 0 if it is in 16-bit units. This reflects bit 29 of the Interrupt Control register.
- 28 Bus Reset. This reflects bit 28 of the Interrupt Control register, which is set to 1 to reset the bus interface, the Unibus, and the Xbus.
- 27 Interrupt Enable. 1 if external interrupt requests are allowed to contribute to the JUMP condition. This reflects bit 27 of the Interrupt Control register.
- 26 Sequence Break. 1 if a sequence break (macrocode interrupt signal) is pending. This flag does nothing except contribute to the JUMP condition. This reflects bit 26 of the Interrupt Control register.

Bit 14 of the SPC stack is used to flag the return address containing it as the address of the main instruction-interpretation loop. The hardware recognizes a RETURN transfer with SPC<14>=1 as completing the interpretation of one instruction and initiating the interpretation of the next. The instruction stream will be advanced to its next unit (byte or halfword) in the cycle following the RETURN transfer. (It is delayed one cycle for obscure timing reasons.) This cycle is free to also execute a useful microinstruction, provided it does not use the LC, VMA, MD, and associated hardware.

Advancing the instruction stream increments the LC, by 1 or 2. If a new word needs to be fetched from main memory, the unincremented LC, divided by 4, is transferred to the VMA and a read cycle is started. A fetch can be required either because the LC points at the first unit of a word or because the LC has been modified since the last instruction stream advance (a branch occurred). It is legal for the instruction which does the RETURN transfer to modify the LC, and a fetch will always be required. If no fetch is required, the RETURN transfer is altered by forcing SPC<1> to 1, skipping over two microinstructions which, in the fetch case, check for a page fault (or interrupt or sequence break) and transfer the new instruction stream word from MD into a scratchpad location.

The instruction stream can also be advanced by a DISPATCH instruction with bit 24 set. In this case, no alteration of the SPC return address occurs. The dispatch should check the NEEDFETCH signal, which is available as bit 31 of the LC functional source, to determine whether a new word is going to be fetched. If a fetch occurs, the DISPATCH should call a subroutine to check for page fault and transfer the new instruction stream word from MD to a scratchpad location. If no fetch occurs, the DISPATCH should drop through. The instruction after the DISPATCH may then operate on the next unit of the instruction stream. This feature is provided to facilitate the use of multi-unit instructions.

The remaining hardware associated with the instruction stream feature implements miscellaneous function 3, which alters the M-rotate field to select the current unit of the instruction stream from the current word, which should be supplied as the M-source. This applies to any operation which uses the rotator: BYTE instructions, DISPATCH instructions, and JUMP instructions which test a bit. The instruction should be coded for the unit (byte or halfword) at the right-hand end of the word. In half-word mode, IR<4> is XOR'ed with LC<1> to produce the high-order bit of the rotate count. In byte mode, IR<4> is XOR'ed with (LC<1> XOR LC<0>), and IR<3> is XOR'ed with LC<0>. The effect, since the LC always has the address of the next instruction, and the bits are numbered from right to left, is as desired. In halfword mode, the low half of the M source is accessed for the even instruction, when LC<1>=1, and the high half is accessed for the odd instruction, when LC<1>=0.



(NO-OP)

;Jump delay

To multiply numbers of less than 32 bits is also possible. With the same initial conditions, after  $n$  steps the high  $n$  bits of the  $Q$  contain the low  $n$  bits of the product, and the remaining bits of the product are in the low bits of the  $M$ -scratchpad location. Two BYTE instructions can be used to extract and combine these bits to produce a right-adjusted product, if the numbers are unsigned.

Division is a little more complex than multiplication. It too goes a bit at a time, using a non-restoring algorithm which either adds or subtracts at each stage. The basic idea is to keep subtracting the divisor from the dividend, shifted over by different amounts, as in long-division by hand. If the subtraction produces a positive result, it "goes in" and a quotient bit of 1 is produced. If the subtraction produces a negative result, it "fails to go in" and a quotient bit of 0 is produced. Instead of backing up and not doing the subtraction, we set a flag that too much has been subtracted, and add instead the next time. This works since the weight of the divisor on the next step is half as much, and  $B - (A/2) = B - A + (A/2)$ . The "flag" is simply the complement of the quotient bit produced, except for the first step when the flag must be forced to OFF.

Division does not handle 2's complement numbers as easily as multiplication does. The algorithm essentially requires all positive numbers, however the hardware automatically takes the absolute value of the divisor by interchanging addition and subtraction if the divisor is negative. It is up to the microcode to make the dividend positive beforehand, and to determine the correct signs for the quotient and remainder afterward. The sign of the quotient should be the XOR of the signs of dividend and divisor. The sign of the remainder should be the same as the sign of the dividend.

Initially the positive dividend is in the  $Q$  register and the signed divisor is in an  $A$ -scratchpad location. Appropriate conditional-ALU operations are used in conjunction with the SHIFT-Q-LEFT and OUTPUT-SELECTOR-LEFTSHIFT-1 functions. An  $M$ -scratchpad location receives the result of each step, and is fed back to the next step. This location initially contains the high 32 bits of the double-length dividend, or 0 if the dividend is single-precision. At each step, the OUTPUT-SELECTOR-LEFTSHIFT-1 operation brings the high bit of the  $Q$  into the low bit of the  $M$ -scratchpad, bringing up another bit of the dividend. At each step, the complement of the sign of the ALU output represents a bit of the quotient and is shifted into the low end of  $Q$ . After 33 steps,  $Q$  contains the positive quotient (which is why it is called the  $Q$ -for-quotient register). The reason why it takes 33 steps rather than 32 is a little difficult to explain. The quotient bit produced by the first step, if 1, indicates "divide overflow", and is not really part of the quotient. When using a single-precision dividend, "divide overflow" can only happen if the divisor is zero, since the initial operation is zero minus the absolute value of the divisor, which is negative unless the divisor is zero.

What is left of the dividend after all the subtractions is the positive remainder. The last step does not use OUTPUT-SELECTOR-LEFTSHIFT-1, so that the  $M$ -scratchpad will receive the remainder rather than the remainder times 2. If the "too much has been subtracted" flag is set, it is necessary to do one final addition to correct

the remainder. This addition simply undoes the previous subtraction, not also doing a new subtraction, because of the omission of the left shift.

The ALU operations for division are:

**DIVIDE-STEP** The conditional add or subtract described above, **SHIFT-Q-LEFT**, and **OUTPUT-SELECTOR-LEFTSHIFT-1**.  $Q\langle 0 \rangle = 0$  serves as the "too much has been subtracted" flag.

**DIVIDE-FIRST-STEP** Identical to **DIVIDE-STEP** except that the "too much has been subtracted" flag is forced to be off.

**DIVIDE-LAST-STEP** Identical to **DIVIDE-STEP** except that the **OUTPUT-SELECTOR-LEFTSHIFT-1** is omitted.

**DIVIDE-REMAINDER-CORRECTION-STEP** The conditional add or subtract logic is used, except subtract is turned into **SETM** by invoking part of the multiply logic. The exchanging of add and subtract if the divisor is negative then applies, doing the right thing. No shifting occurs and **Q** is unchanged.

Division of numbers smaller than 32 bits can be accomplished in less than 33 steps by sufficiently careful shifting of the inputs and outputs.

To illustrate how it all fits together, and show how to do the sign-correction, here is the code for 32-bit division, with a double-precision dividend, in the **CONSLP** format explained later in this document:

```

; Division Subroutine.
; M-AC and M-1 are the high and low words of the dividend, respectively.
; M-2 is the divisor. The quotient is in M-AC, the remainder in M-1.

DIV      (JUMP-GREATER-OR-EQUAL M-AC A-ZERO DIV1)           ;Check for negative dividend
        (JUMP-NOT-EQUAL-XCT-NEXT M-1 A-ZERO DIV0)         ;If so, change sign
        ((M-1 Q-R) SUB M-ZERO A-1)
        ((M-AC) SUB M-AC (A-CONSTANT 1))                 ;Borrow from high if low is zero
DIV0     ((M-AC) SETCM M-AC)                               ;1's complement high dividend
        (CALL DIV2)                                       ;Now, call positive-dividend case
        (POPJ-AFTER-NEXT (M-1) SUB M-ZERO A-1)           ;Make the remainder negative,
        ((M-AC) SUB M-ZERO A-AC)                          ;and change the sign of the quotient

; Divide routine for positive dividend.
DIV1     ((Q-R) M-1)                                       ;Low dividend to Q-R
DIV2     ((M-1) DIVIDE-FIRST-STEP M-AC A-2)               ;First division step
        (JUMP-IF-BIT-SET (BYTE-FIELD 1 0) Q-R DIVIDE-OVERFLOW) ;Error check
(REPEAT 31. ((M-1) DIVIDE-STEP M-1 A-2)                   ;Middle division steps
        ((M-1) DIVIDE-LAST-STEP M-1 A-2)                 ;Final step, quotient in Q-R
        ((M-1) DIVIDE-REMAINDER-CORRECTION-STEP M-1 A-2) ;M-1 gets remainder
        ((M-AC) Q-R)                                       ;Extract quotient from Q-R
        (POPJ-AFTER-NEXT
        POPJ-GREATER-OR-EQUAL M-2 A-ZERO)                 ; divisor is negative,

```

((M-AC) SUB M-ZERO A-AC)

; change sign of quotient

## The Bus Interface

The Bus Interface connects the CADR machine to two busses, the Unibus and the Xbus. The Unibus is a regular pdp11 bus, used to attach peripheral devices, especially commercial devices designed for the PDP11 line. The Xbus is a 32-bit bus used to attach memory and high-performance peripheral devices, such as disk. The bus interface also includes the diagnostic interface, which allows a unibus operator, such as a pdp10, a pdp11, or another lisp machine, to control the operation of the machine, hardware to pass interrupts from the Unibus and the Xbus to the processor, the logic which arbitrates the Xbus, and the logic which arbitrates the Unibus in the absence of a pdp11 on that bus.

The Bus Interface allows the CADR machine to access memory on the Xbus and devices on the Unibus, allows independent devices on the Xbus to access the Xbus (only), and allows Unibus devices to access Xbus memory (through a map since the Unibus address space is not big enough.) Buffering is provided when the Unibus accesses the Xbus, to convert a 32-bit word into a pair of 16-bit words.

The CADR machine sees a 22-bit physical address space of 32-bit words. The top 128K of this, locations 17400000-17777777, reference the Unibus. Each 32-bit word has a 16-bit Unibus word in bits 0-15, and zero in bits 16-31. There is no provision for using byte addressing on the Unibus, nor for read-pause-write cycles. The 128K immediately below the Unibus, locations 17000000-17377777, are reserved for Xbus I/O devices. Locations 0-16777777 are for Xbus memory.

The bus interface includes a number of Unibus registers which control its various functions:

## Spy Feature

Unibus locations 766000-766036 are used for the Spy feature, which is described in detail elsewhere. These locations read and write various internal signals in the CADR machine, and provide the necessary hook for microcode loading and diagnostics.

## Two-Machine Lashup

Two bus interfaces may be cabled together with a single 50-wire flat cable for maintenance purposes. One machine, the debugger, is able to perform reads and writes on the other machine's, the debuggee's, Unibus. Through registers on the Unibus (such as the Spy feature), the debuggee may be diagnosed and exercised. By using the debuggee's Unibus map (described below), the debuggee's Xbus can be exercised. The following locations on the debugger's Unibus control this feature:

- 766100 Reads or writes the debuggee-Unibus location addressed by the registers below.
- 766114 (Write only) Contains bits 1-16 of the debuggee-Unibus address to be accessed.  
Bit 0 of the address is always zero.
- 766110 (Write only) Contains additional modifier bits, as follows. These bits are reset to zero when the debuggee's Unibus is reset.

- 1 Bit 17 of the debuggee-Unibus address.
  - 2 Resets the debuggee's Unibus and bus interface. Write a 1 here then write a 0.
  - 4 Timeout inhibit. This turns off the NXM timeout for all Xbus and Unibus cycles done by the debuggee's bus interface (not just those commanded by the debugger).
- 766104 (Read only) These contain the status for bus cycles executed on the debuggee's busses. These bits are cleared by writing into location 766044 (Error Status) on the debuggee's Unibus. They are not cleared by power up. The bits are documented below under "Error Status".

### Error Status

- 766044 Reading this location returns accumulated error status bits from previous bus cycles. Writing this location ignores the data written and clears the status bits. Note that these bits are not cleared by power up.
- 1 Xbus NXM Error. Set when an Xbus cycle times out for lack of response.
  - 2 Xbus Parity Error. Set when an Xbus read receives a word with bad parity, and the Xbus ignore-parity line was not asserted. Parity Error is also set by Xbus NXM Error.
  - 4 CADR Address Parity Error. Set when an address received from the processor has bad parity. Indicates trouble in the communication between the processor and the bus interface.
  - 10 Unibus NXM Error. Set when a Unibus cycle times out for lack of response.
  - 20 CADR Parity Error. Set when data received from the processor has bad parity. Indicates trouble in the communication between the processor and the bus interface.
  - 40 Unibus Map Error. Set when an attempt to perform an Xbus cycle through the Unibus map is refused because the map specifies invalid or write-protected.
- The remaining bits are random (not necessarily zero).

### Interrupts

The bus interface allows the CADR machine to field interrupts on the Unibus, if no pdp11 is present. If a pdp11 is present, its program can forward interrupts to the CADR machine in a transparent way. The Xbus also can interrupt the CADR machine. The following Unibus locations control interrupts and the Unibus arbitrator:

- 766040 Reading this location returns interrupt status, as follows:
- 1 Disable Interrupt Grant. If this is set, the Unibus arbitrator will not grant BR4, BR5, BR6, and BR7 requests. It will continue to grant NPR



- requests. Powers up to zero.
- 2 Local Enable (read only). 1 means that the bus interface is arbitrating the Unibus. 0 means that a pdp11 is present on the bus and is doing the arbitration.
- 1774 Bits 9-2 contain the vector address of the last Unibus interrupt accepted by the bus interface or simulated by the pdp11 program.
- 2000 Enable Unibus Interrupts. A 1 here causes bit 15 (Unibus interrupt) to be set when the bus interface accepts a Unibus interrupt. This bit is not reset by power-up.
- 4000 Interrupt Stops Grants. A 1 here causes bit 0 (Disable Interrupt Grant) to be set when the bus interface accepts a Unibus interrupt, thus preventing further interrupts until the CADR machine has processed the first interrupt. This bit is not reset by power-up.
- 30000 Bits 13-12 are the "interrupt level" for purposes of Unibus granting. The mapping to normal pdp11 levels is: 0->0, 1->4, 2->5, 3->6. To simulate level 7, turn on Disable Interrupt Grant. These bits are not reset by power-up.
- 40000 Xbus Interrupt (read only). This bit is the interrupt-request line on the Xbus.
- 100000 Unibus Interrupt. A 1 indicates that a Unibus interrupt has been accepted by the bus interface or simulated by a pdp11 program, and is awaiting processing by the CADR program. This bit clears on power-up. Note that the interrupt-request signal to the CADR machine is the OR of bits 14 and 15.
- 766040 Writing this location writes into bits 0 and 10-13 (mask 36001) of the above register. This is used to change the "interrupt level" and to re-enable acceptance of Unibus interrupts after processing an interrupt.
- 766042 Writing this location writes into bits 2-9 and 15 (mask 101774) of the above register. This is used to simulate Unibus interrupts and to clear bit 15 (Unibus Interrupt) after processing an interrupt.

Locations between 766040 and 766136 not mentioned above are duplicates of other locations, and should not be used.

## Unibus Map

Unibus locations 140000-177777 are divided into 16 pages which can be mapped anywhere in Xbus physical address space. Each page is 512 16-bit words or 256 32-bit words long, the same size as the pages of the CADR virtual memory. The first 8 pages can be addressed by a pdp11, while the second 8 are hidden under the pdp11 I/O space. The Unibus map is intended to be used both as a diagnostic path to the Xbus and for operating Unibus peripherals that access memory.

Each Xbus location occupies 4 Unibus byte addresses. It takes two 16-bit Unibus cycles to read or write one 32-bit Xbus location. 16 buffers (one for each page) are provided to hold the data between the two Unibus cycles. As long as each page is only in

use by a single bus-master, the right thing will happen.

An additional feature is that writing an Xbus address of 17400000 or higher through the Unibus map writes into CADR's MD register. This provides a 32-bit parallel data path into the processor for diagnostic purposes. These Xbus addresses are otherwise unusable, because they are used by the processor to address the Unibus.

Unibus locations 766140-766176 contain the 16 mapping registers. Note that these power up to random contents, and should be cleared by an initialization routine. The bit layout is:

100000 Bit 15 is the map-valid bit. If this is 0, this mapping register is not set up, and will not respond to the Unibus; NXM timeout will occur and an Error Status bit will be set.

40000 Bit 14 is the write-permit bit. If this is 0, this mapping register will not respond to Unibus writes; NXM timeout will occur and an Error Status bit will be set.

37777 Bits 13-0 contain the Xbus page number. These bits are concatenated with bits 9-2 of the Unibus address to produce the mapped Xbus address.

## The Xbus

The Xbus is the standard 32 bit wide data bus for the CADR processor. Main memory and high speed peripherals such as the disk control and TV display are interfaced to the Xbus. Control of the Xbus is similar to the Unibus, in that transfers are positively timed and (as far as the devices are concerned) asynchronous. The bus is terminated at both ends with resistive pullups of 390 ohms to ground and 180 ohms to +5 volts, for an effective 123 ohm termination to +3.42 volts. At ground, each termination draws 28 ma. for a total load of 56 ma. The bus is open collector, and may be driven with any device capable of handling the 56 ma. load. The recommended driver is the AMD 26S10, which also provides bus receivers.

A typical read cycle begins with placing the address for the transfer on the -XADDR lines and the parity of the address on the -XBUS.ADDRPAR line. The -XBUS.RQ line is then lowered, initiating the request. The responding device places the requested data on the 32 -XBUS lines and the parity of the data on the -XBUS.PAR line. Should it not be convenient for the device to produce parity (as in the case of I/O registers), the device may assert -XBUS.IGNPAR to notify the bus master that the transfer should not be checked for correct parity. The responding device then asserts -XBUS.ACK, which remains asserted until the -XBUS.RQ signal is removed by the master.

Write requests proceed identically, except that the master asserts -XBUS.WR and the data to be written on the -XBUS lines along with the address lines. All bus masters are required to produce good parity data on writes.

Deskewing delays are the responsibility of the bus master. In particular, it is the responsibility of the bus master to assert good address, write, and data lines 80 ns. prior to asserting -XBUS.RQ, and these lines must be held until the -XBUS.ACK signal drops in response to the master dropping -XBUS.RQ. Responding devices are allowed to assert -XBUS.ACK at the same time they drive read data onto the -XBUS lines. Thus, masters should delay 50 ns. after receiving -XBUS.ACK before dropping -XBUS.RQ and strobing the data. Responding devices are required to drop -XBUS.ACK immediately after -XBUS.RQ is no longer asserted.

Normal bus master arbitration between the CADR processor and the Unibus requests is handled by the bus interface. Devices on the Xbus which must become bus master, such as the disk control, do so by asserting the -XBUS.EXTRQ signal. When the bus becomes free, the bus interface responds by asserting -XBUS.EXTGRANT. This signal is daisy chained between bus master devices on the Xbus, coming in on the -XBUS.EXTGRANT.IN pin and leaving on the -XBUS.EXTGRANT.OUT pin. Within each device, the decision is made whether or not to pass the grant onto the next device. Unlike the Unibus structure, the decision on whether to pass grant and the act of becoming bus master happen synchronously with a master clock signal distributed on the -XBUS.SYNC line.

When a device initiates a request, it immediately asserts -XBUS.EXTRQ. At the falling edge of -XBUS.SYNC it clocks the request signal into a D flip flop which we will call REQ.SYNC. When -XBUS.EXTGRANT.IN goes low, the device asserts -XBUS.EXTGRANT.OUT unless it has either the REQ.SYNC flip flop set, or is already the bus master. At the next falling edge of -XBUS.SYNC the device which has both -XBUS.EXTGRANT.IN and REQ.SYNC set becomes bus master. The device should

immediately assert **-XBUS.BUSY** and may immediately begin asserting address lines for a transfer. **-XBUS.BUSY** may be dropped asynchronously, after the slave device drops **-XBUS.ACK** in response to the master's request.

The **-XBUS.EXTGRANT.IN** signal must be terminated with a resistive pullup of 180 ohms to +5 volts within each device which does not simply connect it to **-XBUS.EXTGRANT.OUT**.

### **XBUS Signal review:**

#### **Data lines:**

<b>-XBUS&lt;31:0&gt;</b>	32 data lines, low when data is a one.
<b>-XBUS.PAR</b>	Parity of the 32 data lines. Required for writes.
<b>-XBUS.IGNPAR</b>	Ignore parity signal, may be asserted by any device for a read.

#### **Address lines:**

<b>-XADDR&lt;21:0&gt;</b>	22 address lines, low for address bit a one.
<b>-XADDR.PAR</b>	Odd parity for the address.

#### **Cycle control lines:**

<b>-XBUS.RQ</b>	Asserted by the master to request a read or write. Minimum of 80 ns following stable <b>-XADDR</b> , <b>-XBUS.WRITE</b> , and <b>-XBUS</b> data.
<b>-XBUS.ACK</b>	Asserted by the slave in response to <b>-XBUS.RQ</b> . No delay necessary following assertion of good read data.
<b>-XBUS.WR</b>	Asserted by the master during a write cycle.

#### **Mastership control lines:**

<b>-XBUS.BUSY</b>	Asserted when a device other than the bus interface is bus master. Only the bus interface examines this line. Asserted on a <b>-XBUS.SYNC</b> clock edge, dropped asynchronously after <b>-XBUS.ACK</b> drops.
<b>-XBUS.EXTRQ</b>	Asserted when a device other than the bus interface wishes to become bus master. Asserted asynchronously, may be removed asynchronously after the device becomes master, but before dropping <b>-XBUS.BUSY</b> .
<b>-XBUS.EXTGRANT.IN</b>	The daisy-chained mastership grant signal. Must be pulled up to +5V with a 180 ohm resistor.
<b>-XBUS.EXTGRANT.OUT</b>	Asserted initially by the bus interface, synchronously with the <b>-XBUS.SYNC</b> edge. The signal may be subject to synchronizer lossage, since it is a clocked version of <b>-XBUS.EXTRQ</b> which is not synchronous

with -XBUS.SYNC

**Miscellaneous:**

**-XBUS.INIT**

When low, resets all devices. This is low during power on and off; and when the machine is reset.

**-XBUS.SYNC**

Synchronization clock for mastership passing and other desired purposes. Devices become bus master synchronous with the edge of this signal. The request will normally follow the edge by 80 ns.

**-XBUS.INTR**

Driving this low requests an interrupt. All devices are required to initialize to a non-interrupt enable condition, and are required to have interrupt enable and disable bits which can selectively enable interrupts from that device. The "requesting interrupt" state must be readable in one of the device control register bits.

**XBUS.POWER.OK**

This line is HIGH when power is stable. It remains low for 3 seconds after power comes on, and goes low 3 seconds before power is turned off.

## **Error Checking**

All internal memories in the CADR machine have parity checking. If bad parity is detected, the machine is halted, if that is enabled. The processor always completes the current instruction, and clocks the next one into the IR, before halting. This is done to simplify the timing and to ensure that it halts with the scratchpad memory latches open. It means that the data with bad parity will no longer be on the busses once the machine stops. Furthermore, one incorrect instruction will have been executed. The OPC registers can be helpful in reconstructing what must have happened.

Upon initial power-on, error halting is disabled, but it is expected that as soon as the bootstrap program has initialized all internal memories it will enable error halting.

Main memory parity is checked and can either halt the machine, cause a microcode trap, or be ignored, depending on mode flags in the diagnostic interface.

The data paths do not have any redundant checking. When the machine is bootstrapped it runs some simple diagnostics designed to detect solid failures in the memories and data paths.

## Self Bootstrapping

When the machine is powered on it resets itself and the Unibus but does not automatically start up. A bootstrap sequence can be initiated in any of several ways. The diagnostic interface can command one. The diagnostic display panel, by grounding one wire, can start one. This is intended to be connected to a push button. The bus interface can start a bootstrap by grounding one wire. The chaos network interface, if it receives a certain sequence of messages from the network, will "push the boot button." The I/O board recognizes a special set of keyboard commands (left and right control-meta) as a boot signal. The character typed along with the left-right control-meta is available to the bootstrap for selection of software options.

The bootstrap sequence starts by resetting the machine, which will halt it if it is running. It turns on RUN, which will not do anything yet since the clock is stopped. It sets the machine to its slowest speed, disables parity traps, error halts, and the statistics counter, and enables the PROM (read-only) control memory. The trailing edge of the boot signal allows the clock to start, causing a trap to microcode location 0, just like the memory parity error trap. Location 0 of the PROM receives control. It must clear all internal memories (filling them with good parity), reset the Unibus (before first using it), enable error halts, set the machine speed to its normal value, run some diagnostic checks to be sure the machine is working to some extent, load the microcode from the disk, load the initial contents of main memory from the disk, and transfer control to the normal microcode at its start address by going over the Unibus and manipulating the diagnostic interface.

If the diagnostic self-test fails, the microcode goes into a loop, and the value of the PC can be read from the diagnostic display to determine what the problem seemed to be.

## Interrupts and Sequence Breaks

Interrupts are hardware signals to the microcode - typically the microcode transfers data in or out of a buffer in main memory. When the signal requires the attention of full Lisp code, a sequence break is triggered. This consists of setting a sequence-break pending flag in A-memory, and, if a defer-sequence-break flag (also in A-memory) is not set, setting the hardware sequence-break flag. This flag is tested at various convenient points such as macroinstruction fetch, and causes the microcode to turn off the flag and enter the sequence-break routines. The sequence-break flag is tested by the same jump instruction that tests for page faults and interrupts.

Interrupts can be generated by both the Xbus and the Unibus. The exact protocol is documented in the section on the bus interface.

Sequence-breaks are software signals indicating the need to run the scheduler (a Lisp program). A sequence-break suggests that the condition for which some process is waiting may have become true. The scheduler checks all processes for runnability, and also checks if it is time to perform periodic actions which are not full processes. Lisp programs can defer sequence-breaks to protect critical areas, while still allowing interrupts so that real-time response at the lowest level is preserved.

Access to virtual memory in the Lisp Machine software environment is viewed as a primitive operation. Regardless of the actual location of a memory datum, the fetch of that item is continued. This view considerably simplifies coding of the system, but imposes moderately high potential latencies in responding to sequence breaks. Interrupts are handled entirely at the microcode level, and the response time for these will be quite short.

The interrupt-control register, writable by functional destination 2, and readable in the high bits of LC (functional source 13), contains three bits relevant to interrupts. Bit <27>, INTERRUPT ENABLE, allows the external interrupt signal from the bus interface to be seen by the JUMP instruction. Bit <26>, SEQUENCE-BREAK, is the sequence-break flag which is testable by the JUMP instruction.

Bit <28>, BUS-RESET, generates a RESET signal on the Unibus (BUS INIT L) and on the Xbus (XBUS.INIT L), and resets the bus interface, when it is written 1 and then 0. The machine also resets the busses when it is powered up.

Bit <29> is used by the Instruction-Stream feature.



## The Statistics Counter

The statistics counter is a 32-bit counter, which increments whenever an instruction with bit 46 = 1 is executed. When the counter overflows from -1 to 0 the machine stops, after completing execution of the instruction which caused the overflow. (The stopping is under control of an enable bit in the diagnostic interface.) Bit 46 is always 0 in instructions from the PROM.

The statistics counter can be read and written using the diagnostic interface. It provides several facilities.

It can be used for metering, to measure how many instructions are executed, possibly restricted to a certain subset of the microprogram. The microcode debugger and console program has commands to set and clear the statistics bits in areas of control memory.

It can be used for breakpointing, by setting the counter to -1 and turning on the statistics bit in those instructions which have breakpoints set on them.

It can be used to find obscure bugs, by setting the statistics bit in all locations of control memory, and setting the appropriate number in the statistics counter to cause the machine to halt just before the point where the error appears, so that it can be single-stepped through the suspect microcode.

The statistics counter is loaded from the Instruction Write Register, rather than the normal diagnostic bus, because of its 32-bit width. Effectively it loads from the M bus with a 1-cycle delay. It is probably not possible for the machine to use the statistics counter on itself, although clever ways might be found.

## The Diagnostic Interface

The diagnostic interface occupies 16 Unibus addresses. It includes a 16-bit diagnostic bus which can be used to read and write various portions of the machine. There are 16 readable locations, and 8 writable locations. A readable location and a writable location at the same address have no relation to each other. The diagnostic bus is used by debugging and maintenance programs, including the "console" program, and in a few cases by the machine itself during bootstrapping.

First we will describe the readable locations. These are sometimes called the "spy feature." Naturally, most of these are somewhat meaningless if read while the machine is running.

766000 IR<15-0>. The low 16 bits of the currently-executing instruction.

766002 IR<31-16>. The middle 16 bits of the currently-executing instruction.

766004 IR<47-32>. The high 16 bits of the currently-executing instruction.

766006 not used

766010 OPC. The OPCs are described below.

766012 PC. The current program counter, which is the address of the next instruction to be executed.

766014 OB<15-0>. The low half of the output bus.

766016 OB<31-16>. The high half of the output bus.

766020 Flag Register 1. This provides various signals associated with starting and stopping the machine. When the machine stops due to a hardware error, this register tells what happened. The bits are:

<15> = -WAIT. 1 if the machine is running or runnable, 0 if it is waiting for memory. See the discussion of Clocks for the exact meaning of WAIT.

<14> = -V1PE. Normally 1, 0 if the level-2 map had a parity error at the last clock.

<13> = -VOPE. Normally 1, 0 if the level-1 map had a parity error at the last clock.

<12> = HIGHOK. 1 if the high runs in the machine are all valid, 0 if some are not. This is essentially a power-supply check, and a check for broken wires.

<11> = -STATHALT. Normally 1, 0 if the machine has been stopped by the statistics counter.

<10> = ERR. 1 if an error condition is present. If ERRSTOP is on in the mode register, the machine is stopped.

- <9> = SSDONE. 1 if a single-step operation has been completed.
- <8> = SRUN. 1 if the machine is trying to run (but it may be stopped by a parity error, by a wait condition, or by the statistics counter).
- <7> = -HIGHERR. 1 if there was HIGHOK at the last clock.
- <6> = -MEMPE. Normally 1, 0 if there was a main memory parity error that was not caught by a trap at the last clock.
- <5> = -IPE. Normally 1, 0 if there was a control memory parity error at the last clock.
- <4> = -DPE. Normally 1, 0 if there was a dispatch memory parity error at the last clock.
- <3> = -SPE. Normally 1, 0 if there was an SPC stack parity error at the last clock.
- <2> = -PDLPE. Normally 1, 0 if there was a PDL-buffer parity error at the last clock.
- <1> = -MPE. Normally 1, 0 if there was an M-scratchpad parity error at the last clock.
- <0> = -APE. Normally 1, 0 if there was an A-scratchpad parity error at the last clock.

**766022** Flag Register 2. This register contains flags associated with pipelining and some miscellaneous control signals which the debugging program likes to see. The bits are:

- <15> = unused
- <14> = unused
- <13> = WMAPD. The previous cycle said to write the map, and this cycle will.
- <12> = DESTSPCD. The previous cycle wrote into the SPC stack by using a functional destination (as opposed to a CALL transfer).
- <11> = IWRITED. The previous cycle did an I-MEM WRITE type of JUMP instruction, and this cycle will write control memory, do a RETURN transfer, and NOP the following cycle.
- <10> = IMODD. The previous cycle used the "OA register" to modify this cycle's instruction, or this cycle's instruction came from the DEBUG-IR (see below). This flag inhibits parity checking of the IR.
- <9> = PDLWRITED. The previous cycle caused a write into the PDL-buffer, and this cycle will do it.
- <8> = SPUSHD. The previous cycle caused a write into the SPC stack, and this cycle will do it.
- <7> = unused
- <6> = unused.
- <5> = IR<48>. This is the parity bit of the IR.
- <4> = NOP. The instruction currently in the IR is not really being executed; this cycle is a NOP cycle.
- <3> = -VMAOK. The last attempt to start a main memory cycle was not successful because the map indicated a page fault.

$\langle \triangleright \rangle$  = JCOND. 1 if the jump-condition is satisfied. Meaningless if the instruction in IR is not a JUMP instruction.

$\langle 1-0 \rangle$  = PCS1-0. These 2 bits select the next PC (the address of the instruction after next.) The encoded values are:

0 = SPC $\langle 13-0 \rangle$  the SPC stack.

1 = IR $\langle 25-12 \rangle$  the address specified by a JUMP instruction.

2 = DPC $\langle 13-0 \rangle$  the dispatch memory.

3 = IPC $\langle 13-0 \rangle$  the PC+1.

766024 M $\langle 15-0 \rangle$ . The low half of the M-source selected by the instruction currently in IR.

766026 M $\langle 31-16 \rangle$ . The high half of the M-source.

766030 A $\langle 15-0 \rangle$ . The low half of the A-source selected by the instruction currently in IR.

766032 A $\langle 31-16 \rangle$ . The high half of the A-source.

766034 ST $\langle 15-0 \rangle$ . The low half of the statistics counter.

766036 ST $\langle 31-16 \rangle$ . The high half of the statistics counter.

Here is a description of the writable registers of the diagnostic interface.

766000 DEBUG-IR $\langle 15-0 \rangle$ . The low 16 bits of an instruction supplied by the diagnostic interface.

766002 DEBUG-IR $\langle 31-16 \rangle$ . The middle 16 bits.

766004 DEBUG-IR $\langle 47-32 \rangle$ . The high 16 bits.

766006 Clock control register. Resetting the machine sets this to zero. The following bits exist:

$\langle 4 \rangle$  = LDSTAT. Setting this to 1, then clocking the machine, causes the statistics counter to load from IWR $\langle 31-0 \rangle$ , which loaded from the M bus on the previous clock.

$\langle 3 \rangle$  = IDEBUG. Setting this to 1 causes the IR to load from the DEBUG-IR instead of the PROM or the control memory, when the machine is clocked. The primary way that the machine can be manipulated through the diagnostic interface is by executing instructions using this mechanism.

$\langle \triangleright \rangle$  = NOP11. Setting this to 1 forces NOP. This allows you to clock the machine, for instance to transfer DEBUG-IR into IR, without the present contents of the IR causing unwanted side-effects by getting

executed as an instruction. NOP11 does not prevent the PC from getting changed (in fact it will be incremented), and it does not prevent previously-scheduled pipelined writes from happening.

- <1> = STEP. Setting this to 1, when SSDONE is 0, causes the processor clock to run for one cycle, and then set SSDONE. Setting STEP to 0 clears SSDONE. (Both of these operations really take several cycles of the clock to complete.) STEP is the way that the diagnostic interface "clocks" the machine. Note that the main clock is running all the time, even when the machine is stopped. STEP generates a single processor clock, in synchronism with the main clock.
- <0> = RUN. Setting this to 1 causes the machine to start running. You first use STEP to set up the state of all the registers and memories, the PC, and the IR, then turn on RUN. The first instruction executed is the one you left in the IR.

**766010 OPC control register.** Resetting the machine sets this to zero. This register contains some bits which need to be used by the console program in order to completely restore the state of the machine from a saved state. The bits are:

- <2> = OPCINH. Setting this to 1 inhibits the OPCs from being clocked by the processor clock. This bit must not be changed except when the clock is high (i.e. the machine is stopped). The process of restoring the OPCs consists of setting OPCINH, then getting the 8 values into the PC by executing JUMP instructions, and transferring those values into the OPCs via the OPCCLK bit. Once the OPCs have been restored, OPCINH remains set so that they will be undisturbed while the rest of the machine state is restored. Just before starting the machine, set OPCINH to 0.
- <1> = OPCCLK. Setting this to 1 and then to 0 generates a clock to just the OPCs. This is used to read out the 8 OPC registers without disturbing the state of the rest of the machine.
- <0> = LPC.HOLD. Setting this to 1 prevents the LPC register from loading from the PC register when the machine is clocked. This is used in restoring the LPC. The LPC is a duplicate copy of the first OPC register, used by the IR<25> feature of the DISPATCH instruction.

**766012 Mode register.** Resetting the machine sets this to zero. This register enables various features and controls the speed of the clock. The bits are:

- <7> = PROG.BOOT. Setting this to 1 starts a bootstrap sequence.
- <6> = PROG.RESET. Setting this to 1 resets the machine. Reset stops the machine by clearing RUN, forces the clock to stop until the RESET operation is over, clears the pipeline flags which cause things to happen in the next instruction, and clears the Clock, Mode, and OPC registers of the diagnostic interface.
- <5> = PROMDISABLE. A 1 here disables the PROM. A 0 here replaces the first 1K locations of control memory with the PROM.
- <4> = TRAPENB. A 1 here enables main memory parity errors to cause

microcode traps to location 0. A 0 here causes main memory parity errors to be treated the same as other parity errors.

<3> = STATHENB. A 1 here enables overflow of the statistics counter to halt the machine.

<2> = ERRSTOP. A 1 here enables hardware errors (HIGHERR and various parity errors) to halt the machine. A 0 causes it to continue blithely on.

<1-0> = SPEED<1-0>. These bits control the speed of the clock. The ILONG bit in the microinstruction also affects the speed, slowing it down by 40 nanoseconds. The speed codes are:

0 = Extra Slow

1 = Slow

2 = Normal

3 = Fast

766014 not used.

766016 not used.

The OPCs are a set of 8 registers which remember the last 8 values of the PC. This provides a useful history for debugging. It is also used by the microcode itself in certain trap-handling routines. You can only read the last of the 8 OPCs, which is what the PC was 8 clocks ago. Special control is provided over the clocking of the OPCs so that they can be read out without di so that they can be saved and restored by the microcode debugger. This is described above under 766010.

The OPCs can be read both by the diagnostic interface and as a functional source, for maximum flexibility.

The bus interface provides a special path by which the MD register may be loaded. This provides a parallel source of diagnostic input data. After loading MD, instructions can be executed via the DEBUG-IR to transfer the data to the desired destination.

There are several maintenance indicators (light-emitting diodes) scattered around the machine. Inside the front door, near the lower-left-hand corner, are 5 octal displays. These show the current value of the PC. The decimal points on these displays show various interesting conditions. From left to right:

1 - PROMENABLE. Indicates that the current instruction is coming from the PROM rather than the writable control memory.

2 - IPE. Indicates that control memory had a parity error at the last clock.

3 - DPE. Indicates that dispatch memory had a parity error at the last clock.

- 4 - TILT0. Indicates that the map or main memory had a parity error at the last clock.
- 5 - TILT1. Indicates that the A-scratchpad, the M-scratchpad, the PDL-buffer, or the SPC stack had a parity error at the last clock.

There is also provision for indicators for the various error conditions, "the machine is really running," and the status of the disk interface. The location of this indicator panel, and whether or not all machines will have one, is not yet determined.

## The Disk Controller

The Lisp machine disk controller attaches from 1 to 8 disk units of the "Trident" family to the CADR machine's XBUS. The 1-unit version consists of one board, and a second board is added when more than one disk unit is to be used. The two versions are almost program compatible.

### Interface Registers

The disk controller is operated by reading and writing four 32-bit registers which are on the XBUS. These are normally at physical addresses 17377774-17377777, which is just below the Unibus. The address can be changed by changing jumpers. Many bits in these registers refer to the "selected unit", which is that disk unit whose number is currently in bits <30:28> of the disk-address register.

When read, the registers are:

#### 0 STATUS

- <24:31> The block-counter of the selected unit. This tells you its current rotational position. Reading of this register is not synchronized to its incrementation, so you must read it twice and check that it came out the same both times.
- <23> Internal Parity Error. This indicates that parity of the bits seen at the disk and parity of the bits seen at the memory failed to agree; something must have been lost inside the controller someplace. The Read All and Write All commands cause spurious internal parity errors. The Read Compare command causes a spurious internal parity error if it sets Read Compare Difference (bit 22) and the the disk data and the memory data differ in parity. This error does not stop the transfer.
- <22> Read Compare Difference. This indicates that data from memory and data from the disk failed to agree. This bit is undefined unless the command is read-compare. This error does not stop the transfer.
- <21> CCW Cycle. This bit being on in combination with Memory Parity Error or Nonexistent Memory Error indicates that the error happened while fetching a CCW, rather than while reading or writing data.
- <20> Nonexistent Memory Error. Indicates that memory (or other XBUS device) failed to respond within 15 microseconds. This error stops the transfer.
- <19> Memory Parity Error. Indicates that even parity was read from memory (or other XBUS device). This error stops the transfer.
- <18> Header Compare Error. Indicates that a block-header read from disk failed to have the expected value. This may be because the disk head is not positioned at the proper place, because the disk is not correctly formatted, or because the header wasn't read correctly. This error stops the transfer.
- <17> Header ECC Error. Indicates that the error-correcting code of a block header failed to check. Unfortunately most header ECC errors show up as header compare errors instead. Maybe this can be fixed? This error stops the transfer. Header ECC Error also happens if an attempt is made to continue a



- read or write operation past the end of the disk.
- <16> **ECC Hard.** Indicates that the error correcting code discovered an error, and was unable to correct it. The data read from disk is wrong, try reading again. This error stops the transfer.
  - <15> **ECC Soft.** Indicates that the error correcting code discovered an error, and was able to determine which data bits were in error. The program can correct it, see the ECC Register for how. The error correcting code will correct any single burst of up to 11 erroneous bits. This error stops the transfer.
  - <14> **Read Overrun.** Indicates that data arrived from the disk faster than it could be stored into memory. This error stops the transfer.
  - <13> **Write Overrun.** Indicates that memory did not supply data fast enough for the disk. This error stops the transfer.
  - <12> **Start Block Error.** Indicates that a start-of-block (sector pulse) happened at a time when it should not have. Either the disk is incorrectly formatted or it is generating spurious sector pulses. This error stops the transfer.
  - <11> **Timeout Error.** Indicates that a disk operation took longer than 2.5 seconds. This error stops the transfer.
  - <10> **Selected Unit Seek Error.** The selected unit is reporting failure of a seek operation. This error stops the transfer. Reset the error by using the Recalibrate command.
  - <9> **Selected Unit not On-line.** The heads are not loaded, the disk is not powered on, or there is no disk at the specified unit number. This error stops the transfer.
  - <8> **Selected Unit not On-Cylinder.** Generally indicates that a seek is in progress on the selected unit. Not an error. If the disk goes off-cylinder during a write operation, a fault will occur. If it goes off cylinder during a read, presumably a header-compare error or an ECC error will occur.
  - <7> **Selected Unit Read-Only.** The status of a switch on the disk. Note that the read-only status can only change to reflect a change in the switch when the drive is not selected. Storing into the Disk Address register momentarily deselects the current unit so that it may update its read-only status from the switch. Writing while the disk is read-only causes a fault.
  - <6> **Selected Unit Fault.** Indicates either trouble with the disk or a programming error, see the Trident manual. This error stops the transfer. Reset by using the Fault Clear and/or Recalibrate commands. This error lights the Device Check light on the drive.
  - <5> **No Unit Selected.** This error stops the transfer. Happens if no disk is plugged into the selected unit number, or the disk unit is powered off or "degated".
  - <4> **Multiple Units Selected.** This error stops the transfer. This indicates that more than one disk drive is selected, or the wrong drive is selected.
  - <3> **Interrupt Request.** 1 means the disk controller is asserting - **XBUS.INTR.**
  - <2> **Selected Unit Attention.** Reset using the At Ease command. Attention indicates seek completion, recalibrate completion, initial loading of

the heads, seek incomplete error, or an emergency head retract. "Implicit" seeks do not cause attention.

- <1> Any Attention. Some unit has an attention, you have to select them one after another to find out which.
- <0> Not Active. 0 means the controller is busy, 1 means it is ready to accept a command.

## 1 MEMORY ADDRESS

- <31:24> not used
- <23:22> Disk type. 00 Trident 01 Marksman 10 unused 11 Trident (old control)
- <21:0> the address of the last memory reference made by the disk control. This is the address of a CCW if CCW Cycle is on in the status register, otherwise the address of a data word.

## 2 DISK ADDRESS

- <31> not used
- <30:28> Unit number. In the 1-unit version, always zero.
- <27:16> Cylinder number. A T-80 has 815 cylinders.
- <15:8> Head number. A T-80 has 5 heads. As it turns out, only the bottom 6 bits of the head number can work (this is a feature of the Trident.)
- <7:0> Block number. A T-80 is usually formatted with 17 blocks per track. "Block" is mostly synonymous with "sector".

When a transfer is terminated by an error, the disk address register contains the address of the block being transferred when the error occurred. When a transfer terminates normally, the disk address register has the address of the last block transferred.

## 3 ERROR CORRECTION REGISTER

- <31:16> Error pattern bits.
- <15:0> Error bit position+1.

When a soft ECC error occurs, this register tells where in the last block transferred the error was. The disk address register has the disk address of the block containing the error, and the command list pointer points to the CCW which points to the memory page containing the error. The error pattern should be XOR'ed into the contents of memory at the specified bit address; it may overlap across a word boundary. Note that the bit position is off by 1; the first bit in the block is bit 1.

You should not write any register while a transfer is active, except for using the Reset command to stop a hung transfer, and even then you should expect to lose.

When written, the registers are:

## 0 COMMAND

Writing the command register does NOT initiate a transfer, unlike most disk

controllers. Use register 3 (START) to initiate a transfer, after setting up the other registers. However, writing the command register does reset the various error flags. Note that the command register cannot be read back.

<31:12> not used

<11> Done Interrupt Enable. Enables not-active (bit 0 of the status register) to cause an interrupt. The interrupt will keep happening until you clear this bit. (This is really an idle interrupt rather than a done interrupt.)

<10> Attention Interrupt Enable. Enables any-attention (bit 1 of the status register) to cause an interrupt. (The interrupt will only happen if the controller is not active. While the controller is active you couldn't do anything about it anyway.) The interrupt will keep happening until you select the drive and give an at-ease command, or clear this bit.

<9> Recalibrate. In combination with command 5, causes the disk to return the heads to cylinder 0.

<8> Fault Clear. In combination with command 5, resets most fault conditions in the disk.

<7> Data Strobe Late. For recovery of marginal data.

<6> Data Strobe Early. For recovery of marginal data.

<5> Servo Offset. For recovery of marginal data, offsets the heads slightly. Bit 4 controls which direction. Note that this is somewhat kludgy, if you try to seek while the heads are offset you get a fault. (use command 6 first to clear the offset.) Transferring more than one block at a time while in servo offset mode, or even retrying a transfer without first doing an offset clear, will probably cause a fault. Of questionable worth anyway. Writing while the heads are offset causes a fault.

<4> Offset forward. 1 means offset forward, 0 means offset backward.

<3> I/O Direction. 1 means from-memory, 0 means to-memory. See below for valid combinations.

<2:0> Command code. The following combinations of bits are valid commands (here expressed in octal). Note that bits 10 and 11 may always be turned on, and bits 4 through 7 may be turned on in any reading command.

0000 Read.

0010 Read-compare. Reads from both disk and memory, and sets bit 22 of the status register if they don't agree.

0011 Write.

0002 Read All. Reads all bits of the disk starting at the specified rotational position. Note that internal parity errors will occur spuriously during this command, and that it will not automatically advance heads and cylinders. See the description of disk formatting below.

0013 Write All. Writes all bits of the disk starting at the specified rotational position. This is intended for formatting the disk, see below. The caveats under READ ALL apply to WRITE ALL also. In addition, it doesn't really write quite all of the last page; somewhere between zero and seventeen words will be lost.

- 0004 Seek. Initiates a seek to the cylinder specified in the disk address register. An attention will occur when the seek completes. Note that this command is not logically necessary; the controller always initiates a seek if necessary at the start of a data transfer command. The read, read-compare, and write commands also will seek in the middle of a transfer when necessary. The seek command is provided so you can overlap seeks on multiple units.
- 0005 At ease. Resets attention on the selected unit.
- 1005 Recalibrate. Seek to cylinder 0, without assuming the current position of the heads is correct. This is used to correct a seek error, and as part of error recovery. Recalibrate resets some error conditions in the drive, and causes an attention when complete.
- 0405 Fault clear. Resets most error conditions in the drive.
- 1405 This probably does both a Recalibrate and a Fault Clear.
- 0006 Offset clear. Take the heads out of the offset state. This does not wait for completion, but the next command will.
- xxx7 This is a reserved command, and will currently hang the controller, causing a timeout error (bit 11 in the status register.)
- 0016 Reset. This stops the current transfer and resets the controller. This command takes effect as soon as it is stored in the command register; no store in START is required. After storing a Reset command you should store 0 in the command register to turn off the reset condition. Use of Reset while a transfer is in progress isn't guaranteed not to do strange things.

All commands except for the xxx5 group and Reset wait for completion of any previous seek operation on the selected unit before starting. Thus even the Seek and Offset Clear commands can take finite time before the controller is ready for the next command.

## 1 COMMAND LIST POINTER

This is the address of a vector of Channel Command Words (CCWs) which specify what memory pages, and how many, are to be transferred to/from disk. Only bits <15:0> of the CLP can count, so if you try to carry across this boundary your command list will wrap around.

The format of a CCW is:

- <31:24> not used
- <23:8> Main memory address of a page
- <7:1> not used
- <0> More flag. If this bit is 0, this is the last CCW in the list. If this bit is 1, there is another CCW in the following location.

## 2 DISK ADDRESS

See the description of the disk address register under reading. Note that in the 1-unit version, the unit number bits <30:28> are ignored and regarded as always zero.

**3 START:**

Writing anything at this address initiates the operation specified in the command, disk address, and command list pointer registers.

**Disk Structure**

Each disk block contains one Lisp machine page worth of data, i.e. 256. words or 1024. bytes. You can transfer up to 65536. consecutive disk blocks to non-consecutive memory locations in a single operation, or you could if the machine supported that much main memory. A T-80 has 815. cylinders, each with 5 heads (tracks), each with 16. or 17. blocks depending on how you feel like formatting it. A T-300 is the same except it has 19. heads.

**Formatting**

The format is determined by the program that uses the Write All operation to format the disk, within the constraints determined by the hardware. A track contains (approximately) 20160. bytes (on a T-80 or a T-300). Jumpers in the disk are set to give 17. sector pulses per track, or one every 1164. bytes, with a little left over at the end of the track.

Everything goes low-order bit first and low-order byte first. Note that bits in the disk controller are the complement of bits seen by the drive. Thus all bits in the Trident manual should be thought of as complemented.

The format of a block is:

(sector pulse here)

PREAMBLE - 53. bytes of ones.

VFO LOCK - 8. bytes of ones.

SYNC - a byte containing octal 177

HEADER - a 32-bit word as follows:

<31:30> next block address code:

0 following block on same track

1 block 0 on next track (next head)

2 block 0 on head 0 of next cylinder

3 end of disk

<29:28> not used, should be zero

<27:16> cylinder number, used to verify that the disk is positioned to the correct cylinder.

<15:8> head number, used to verify the head selection.

<7:0> block number, used to verify the rotational position.

HEADER ECC - a 32-bit checkword.

VFO RELOCK - 20. bytes of ones.

SYNC - a byte containing octal 177

**PAD** - a byte containing octal 377, which is here to fix a bug in the logic for read-compare. (Ugh)  
**DATA** - 1024. bytes of whatever you want.  
**DATA ECC** - a 32-bit checkword.  
**POSTAMBLE** - 44. bytes of ones.

To format the disk, you should do it one track at a time. Lay out in memory the bits to be written on the track. Truncate the length to a multiple of a page, but make sure that the last 17. words don't matter (in general you will be writing 19. pages, or 19456. bytes, leaving about 771. bytes at the end of the track which may not get written, depending on how full the fifo is when the operation terminates. Depending on the block length chosen, you may not get a chance to fully write the last block, but as long as you get into the data area it will be all right. Do a WRITE ALL command of this data, with a disk address whose block-number field (bits <7:0>) is zero. Ignore any internal parity error (bit 23 of the status register.) You can verify it by using the Read All command (but the internal parity and read-compare features will not work), or you can use the ordinary write and read commands. You must compute the ECC check-words manually. The polynomial is  $x^{31}+x^{29}+x^{20}+x^{10}+x^8+1$  [if I understand this logic correctly.]

Note that, when using Read All, there is some ambiguity as to precisely where the data read starts. It is unlikely to line up the bytes on byte boundaries. The first several microseconds worth of data will be missing or corrupted.

## Debugging

Connector J11 is provided for a flat cable to an LED display, with the following useful signals on it. These are ground when inactive, 15 milliamps at +3 volts or so when active.

- 1 Read Active. The controller is active and bit 0 of the command register is 0.
- 2 Write Active. The controller is active and bit 0 of the command register is 1.
- 3 Seek. The selected unit is not on-cylinder.
- 4 Transfer Lossage. This is the IOR of Timeout, Read Overrun, Write Overrun, Memory Parity Error, and Nonexistent Memory Error.
- 5 Format Lossage. This is the IOR of Start Block Error, Header Compare Error, Header ECC Error, and Reset.
- 6 ECC Lossage. This is the IOR of Hard ECC Error and Soft ECC Error.
- 7 Disk Lossage. This is the IOR of Multiple Units Selected, No Units Selected, Selected Unit Fault, Selected Unit not On-Line, and Selected Unit Seek Error.
- 8 Spare. This probably does not light up.

<<Here insert a one-page table of instruction formats and so forth>>

the expression program is evaluated to produce the symbol's value (which may be conditional on the context in which it appears). Expression programs are discussed in a later section.

## Instructions

In general, CONSLP assembles a list into a data item by evaluating all the elements of the list and adding them up. There is a fairly rich language for specifying complex expression programs and assigning symbolic names to them; for now, however, we will merely use the symbols predefined by CONSLP. CONSLP also allows the fields of an instruction to be written in almost any order, but we will describe only the conventional order for writing them.

The general form of an I-MEM instruction is:

```
(<popj> (<destinations>) <operation> <condition>
  <M-source> <byte-descriptor> <A-source> <target-tag> <other fields>)
```

The <popj> field is POPJ-AFTER-NEXT to specify that the POPJ bit be set.

The <destinations> field may be an A or M memory tag, or the name of a functional destination, or both an M memory tag and a functional destination.

The <operation> specifies the instruction type, and possibly other fields (such as the jump condition) as well.

The <condition> may also be a separate field, though it usually is encoded as part of the operation.

The <byte-descriptor> describes the byte to be used in a BYTE or DISPATCH instruction.

The <M-source> and <A-source> specify the sources; these may be tags in the appropriate memories, or, for the <M-source>, the name of an M multiplexor source.

The <target-tag> is an I-MEM tag for JUMP instructions, or a D-MEM tag for DISPATCH instructions.

The <other fields> can be such things as the Q control and Miscellaneous Functions.

Many of these fields can be omitted, and CONSLP will default them appropriately. If the <operation> is omitted, then ALU is assumed, unless a <byte descriptor> is present either implicitly or explicitly, in which case BYTE is assumed. If only one source is present in an ALU instruction, then an opcode of SETA is supplied for an A source, and SETM for an M source, thus causing a simple movement of data. If the A source is omitted in a BYTE instruction, then location 2 in A memory is assumed (which is supposed to contain zero).

Here are some examples of instructions, with commentary. We assume the convention described above for A and M memory tags.

```
((A-FOO) M-BAR) ;move from BAR in M-MEM to FOO in A-MEM
```

```
(CALL ZAP) ;do a CALL transfer to instruction ZAP (N bit set)
```



```

((A-FOO) SUB M-BAR A-BAZ)
        ;subtract A-BAZ from M-BAR, put result in A-FOO

(JUMP-EQUAL-XCT-NEXT M-BAR A-FOO LOSE)
        ;jump to LOSE if M-BAR equals A-FOO; N bit is clear,
        ; so instruction after the JUMP is executed
        ; whether or not the JUMP succeeds

(POPJ-AFTER-NEXT (M-FOO) MEMORY-DATA)
        ;put data from memory into M-FOO,
        ; and also POPJ after next instruction

((M-SAVE MEMORY-DATA-START-WRITE)
  ADD MEMORY-DATA A-ZERO ALU-CARRY-IN-ONE)
        ;add one to the read memory data,
        ; transfer to write memory data and M-SAVE,
        ; and begin writing the data into main memory
        ; at the address already in the VMA

```

## Literals

CONSLP provides a facility for specifying literals in the A and M memories. The constructs

```
(A-CONSTANT <expression>) and (M-CONSTANT <expression>)
```

may appear as an A source or M source specification, causing CONSLP to allocate a word in the appropriate memory, assemble the literal expression there, and use the address of that location as the source location. If the same constant in the same memory is referenced many times, CONSLP will assemble only one copy of it. Two constants are considered the same if their final binary values are identical, regardless of the source expressions which reduced to those values. The zero constant is treated specially, and made to refer to location 2 of the appropriate memory (hence the user should reserve these locations as constant sources of zeros). Similarly the -1 constant is made to refer to location 3 of the appropriate memory.

## Byte Specifications

Rather than requiring the user to calculate the rotation count and length (minus 1) fields for BYTE and DISPATCH instructions, CONSLP provides a uniform method for specifying a byte in terms of its size and position in the word; CONSLP then calculates the fields appropriately.

The simplest way to describe a byte is with the BYTE-FIELD construct:

**(BYTE-FIELD <size in bits> <position from right>)**

For example, (BYTE-FIELD 5 0) is the low five bits of a word, and (BYTE-FIELD 7 5) is the seven bits above them. The two arguments to BYTE-FIELD must be constant integers.

Another way to describe a byte is:

**(LISP-BYTE <ppss>)**

where the low two octal digits of <ppss> are the size and the next two are the position. The argument <ppss> is evaluated as a LISP form (see below under "Expression Programs").

When a byte specifier appears in an instruction, the op-code is defaulted to BYTE, and the type of byte instruction defaulted to "load byte". If specified elsewhere in the instruction, the op-code may be DISPATCH instead; the dispatch is based on the specified byte. The op-code may also be JUMP, but only if the byte is one bit wide; this means that the jump will test the specified bit of the M source.

When CONSLP assembles the final instruction, it constructs the rotation count and length minus 1 fields on the basis of the byte specifier and the operation to be performed. For JUMP, DISPATCH, and "load byte" type BYTE instructions, this involves subtracting the byte position from 32 to obtain the correct rotation count. (Recall that CADR rotates words to the left.) If Miscellaneous Function 3 (LOW PC BIT specifies half word) is enabled, then the position (which should be less than 16) is subtracted from 16 instead. For "deposit byte" and "selective deposit" type BYTE instructions, the byte position itself is used as the rotation count. The length minus 1 field for BYTE and JUMP is computed by subtracting 1 from the byte length, unless the byte length is zero, in which case zero is used. (Note that CADR cannot really handle zero-length bytes, but CONSLP allows them to be defined on the theory that the "next instruction modify" feature may be in use. Programs which use this feature must be aware of the hackery which the assembler pulls, and allow for the actual values of the fields at run time.) The DISPATCH instruction has a length field instead of a length minus 1 field, and so no subtraction of 1 is performed for it.

Here are some examples of the use of byte specifiers:

**((M-X) (BYTE-FIELD 7 4) M-Y)**

```

:extracts a 7-bit byte, 4 bits from
: the right, from M-Y, and puts this
: byte right-justified in M-X. The
: A source is defaulted to 1, which
: should be a constant zero so that the
: other bits in M-X will be zero.

```

**(JUMP-IF-BIT-SET (BYTE-FIELD 1 3) M-ZAP QUUX)**

```

:jump to QUUX if the "10" bit is set in M-ZAP

```

**(DISPATCH (BYTE-FIELD 3 0) M-ZAP DTABLE)**

```

;use the low three bits of M-ZAP to index
; into the dispatch table DTABLE

```

It is possible to create a symbolic name for a byte field by using the ASSIGN pseudo-operation:

```
(ASSIGN LOW-HEX-DIGIT (BYTE-FIELD 4 0))
```

Since this is a common operation, another pseudo-op exists for the purpose:

```
(DEF-DATA-FIELD <symbol> <byte size> <byte position>)
```

For example:

```
(DEF-DATA-FIELD LOW-HEX-DIGIT 4 0)
```

It is also possible to associate a name with a byte field in a particular register. One way to do this is to sum the byte specifier and the name of the register:

```
(ASSIGN CONDITION-CODES (PLUS (BYTE-FIELD 4 0) PDP-11-PS))
(ASSIGN TRACE-TRAP-BIT (PLUS (BYTE-FIELD 1 4) PDP-11-PS))
(ASSIGN PRIORITY (PLUS (BYTE-FIELD 3 5) PDP-11-PS))
```

This case too is common enough to warrant a special pseudo-operation for the purpose:

```
(DEF-BIT-FIELD-IN-REG <symbol> <byte size> <byte position> <register>)
```

For example:

```
(DEF-BIT-FIELD-IN-REG CONDITION-CODES 4 0 PDP-11-PS)
(DEF-BIT-FIELD-IN-REG TRACE-TRAP-BIT 1 4 PDP-11-PS)
(DEF-BIT-FIELD-IN-REG PRIORITY 3 5 PDP-11-PS)
```

Note that the <register> had better be in the M-scratchpad. With this definition, it is only necessary to mention, say, PRIORITY, in an instruction to cause an appropriate byte reference to occur:

```
((A-PRIORITY) PRIORITY) ;extract the PRIORITY byte from PDP-11-PS
; and place it right-justified in A-PRIORITY
```

By special dispensation, it also works to use such symbols in the destination field. The appropriate DPB is assembled.

Two more pseudo-operations make it easy to define names for many consecutive bits or fields in a register.

(DEF-NEXT-FIELD <symbol> <byte size> <register>) .sp This defines <symbol> to be a byte of the specified size, in a position to the left of any fields already defined by DEF-NEXT-FIELD. If this is the first DEF-NEXT-FIELD for the specified register, then the field position is zero (at the low end of the word). For example:

```
(DEF-NEXT-FIELD REL-OFFSET 8 IBM-1130-INSTRUCTION)
(DEF-NEXT-FIELD TAG-FIELD 2 IBM-1130-INSTRUCTION)
(DEF-NEXT-FIELD FORMAT-BIT 1 IBM-1130-INSTRUCTION)
(DEF-NEXT-FIELD OP-CODE 5 IBM-1130-INSTRUCTION)
```

would be entirely equivalent to:

```
(DEF-BIT-FIELD-IN-REG REL-OFFSET 8 0 IBM-1130-INSTRUCTION)
(DEF-BIT-FIELD-IN-REG TAG-FIELD 2 0 IBM-1130-INSTRUCTION)
(DEF-BIT-FIELD-IN-REG FORMAT-BIT 1 10. IBM-1130-INSTRUCTION)
(DEF-BIT-FIELD-IN-REG OP-CODE 5 11. IBM-1130-INSTRUCTION)
```

The pseudo-operation:

```
(DEF-NEXT-BIT <symbol> <register>)
```

is entirely equivalent to:

```
(DEF-NEXT-FIELD <symbol> 1 <register>)
```

and so allocates a single bit. It may be intermixed freely with DEF-NEXT-FIELD. For example:

```
(DEF-NEXT-FIELD CONDITION-CODES 4 PDP-11-PS)
(DEF-NEXT-BIT TRACE-TRAP-BIT PDP-11-PS)
(DEF-NEXT-FIELD PRIORITY 3 PDP-11-PS)
```

The construct:

```
(RESET-BIT-POINTER <register>)
```

may be used to reset the pointer into <register> used by DEF-NEXT-FIELD and DEF-NEXT-BIT. This is useful if the data in <register> can have several different formats. For example:

```
(DEF-NEXT-BIT C PDP-11-PS)
(DEF-NEXT-BIT V PDP-11-PS)
(DEF-NEXT-BIT Z PDP-11-PS)
(DEF-NEXT-BIT N PDP-11-PS)
(RESET-BIT-POINTER PDP-11-PS)
(DEF-NEXT-FIELD CONDITION-CODES 4 PDP-11-PS)
```

```

(DEF-NEXT-BIT TRACE-TRAP-BIT PDP-11-PS)
(DEF-NEXT-FIELD PRIORITY 3 PDP-11-PS)

(DEF-NEXT-FIELD DST-REG 3 PDP-11-INSTRUCTION)
(DEF-NEXT-FIELD DST-MODE 3 PDP-11-INSTRUCTION)
(DEF-NEXT-FIELD SRC-REG 3 PDP-11-INSTRUCTION)
(DEF-NEXT-FIELD SRC-REG 3 PDP-11-INSTRUCTION)
(DEF-NEXT-FIELD OP-CODE 4 PDP-11-INSTRUCTION)
(RESET-BIT-POINTER PDP-11-INSTRUCTION)
(DEF-NEXT-FIELD BRANCH-OFFSET 8 PDP-11-INSTRUCTION)
(DEF-NEXT-FIELD BRANCH-CONDITION 3 PDP-11-INSTRUCTION)
(RESET-BIT-POINTER PDP-11-INSTRUCTION)

```

## Dispatch Tables

When assembling into the dispatch memory (i.e. (LOCALITY D-MEM)) it is necessary to use two special pseudo-operations, START-DISPATCH and END-DISPATCH, to allocate blocks of dispatch memory. These pseudo-operations specify the length of the block required, and CONSLP undertakes to pack the various odd-sized blocks into the dispatch memory in an appropriate manner.

The typical form for a dispatch block is:

```

(START-DISPATCH <log2 of size> <constant data>)
<dispatch table tag>
    <first word of table>
    ...
    <last word of table>
(END-DISPATCH)

```

The <log2 of size> is the number of bits that will be dispatched on, that is, the logarithm base 2 of the size of the dispatch block. The <constant data> will be added into each of the words of the dispatch table; this is useful for the P, R, and N bits (which in CONSLP are called P-BIT, R-BIT, and INHIBIT-XCT-NEXT-BIT). The END-DISPATCH is logically not necessary, but is used for error checking. Exactly the correct number of words must be assembled between the START-DISPATCH and END-DISPATCH, or CONSLP will give an error message.

As an example of a dispatch table, consider this code:

```

(LOCALITY M-MEM)
PDP-11-INSTRUCTION      (0)      ;HOLDS SIMULATED PDP-11 INSTRUCTION
(DEF-NEXT-FIELD DST-REG 3 PDP-11-INSTRUCTION)
(DEF-NEXT-FIELD DST-MODE 3 PDP-11-INSTRUCTION)
(DEF-NEXT-FIELD SRC-REG 3 PDP-11-INSTRUCTION)
(DEF-NEXT-FIELD SRC-REG 3 PDP-11-INSTRUCTION)
(DEF-NEXT-FIELD OP-CODE 4 PDP-11-INSTRUCTION)

```

```

...
(LOCALITY I-MEM)
  (DISPATCH-CALL-XCT-NEXT DST-MODE D-DST-MODE)
...

(LOCALITY D-MEM)
(START-DISPATCH 3 P-BIT)
D-DST-MODE
  (DST-REGISTER)           ;R0
  (DST-REG-INDIRECT)       ;@R0
  (DST-AUTO-INCREMENT)     ;(R0)+
  (DST-AUTO-INC-INDIRECT)  ;@ (R0)+
  (DST-AUTO-DECREMENT)    ;-(R0)
  (DST-AUTO-DEC-INDIRECT)  ;@ -(R0)
  (DST-INDEXED)           ;N(R0)
  (DST-INDEXED-INDIRECT)  ;@N(R0)
(END-DISPATCH)

```

Note that the use in I-MEM of the op-code DISPATCH-CALL-XCT-NEXT is purely for cosmetic purposes, to indicate that the P bit but not the N bit is a constant in all of the dispatch table entries; it is otherwise identical to the DISPATCH op-code.

## Standard Operation Codes

CONSLP supplies a large number of initial symbols for various operations, particularly for the various conditional jumps. While it is possible to define different ones, use of these standard ones is naturally encouraged. (These symbols are defined in the file LISPM; CONSYM >.)

## ALU Operations

The standard ALU operations supplied by CONSLP are:

### Boolean

SETCM	set to complement of M
ANDCB	AND together complements of both M and A
ANDCM	AND complement of M with A
SETZ	set to zeros
ORCB	OR together complements of both M and A
SETCA	set to complement of A
XOR	XOR (exclusive OR) M and A
ANDCA	AND M with complement of A
ORCM	OR complement of M with A

EQV	EQV M and A (complement of XOR)
SETA	set to A
AND	AND together M and A
SETO	set to ones
ORCA	OR M with complement of A
IOR	OR M and A (inclusive OR)
SETM	set to M

Arithmetic

ADD	M plus A (two's complement addition)
SUB	M minus A (two's complement subtraction)
M+M	M plus M (two's complement addition)
M+M+1	M plus M plus 1
M+A+1	M plus A plus 1
M-A-1	M minus A minus 1
M+1	M plus 1

Conditional Arithmetic

MULTIPLY-STEP  
 DIVIDE-FIRST-STEP  
 DIVIDE-STEP  
 DIVIDE-LAST-STEP  
 DIVIDE-REMAINDER-CORRECTION-STEP

The conditional ALU operations for multiplication and division are explained in detail in a later section.

The output bus selector field defaults to 1 (output bus gets ALU output). The other two choices must be specified explicitly:

OUTPUT-SELECTOR-RIGHTSHIFT-1  
 OUTPUT-SELECTOR-LEFTSHIFT-1

The Q control field of an ALU instruction may be specified by using one of these symbols:

SHIFT-Q-LEFT    shift Q left (shifts inverse of ALU<31> into Q<0>)  
 SHIFT-Q-RIGHT    shift Q right (shifts ALU<0> into Q<31>)  
 LOAD-Q    load Q from output bus

If none of these is present, the default is to do nothing to Q. (Instead of writing LOAD-Q, one may write Q-R in the destination portion of the instruction. This does not mean that Q is a functional destination; it merely forces the operation to be ALU, and forces the Q control field to be LOAD-Q.)

The carry field may be specified by ALU-CARRY-IN-ZERO or ALU-CARRY-IN-ONE. Note that the SUB, M+M+1, M+A+1, and M+1 operations have ALU-CARRY-IN-ONE as part of their definitions, so it is not necessary to specify it explicitly.

## BYTE operations

If a byte specifier is present in an instruction and the op-code is not explicitly forced to be JUMP or DISPATCH, then the op-code is BYTE by default, performing a "load byte" type of operation.

To get a "deposit byte" type operation, the symbol DPB is used; similarly, to get a "selective deposit", SELECTIVE-DEPOSIT is used. For example:

```
((A-FOO) DPB M-BAR (BYTE-FIELD 3 6) A-FOO)
    ;a true PDP-10 style DPB; the low octal
    ; digit of M-BAR replaces the third lowest
    ; octal digit of A-FOO.

((A-ZAP) DPB M-BAR (BYTE-FIELD 3 6) A-FOO)
    ;similar, but the result is placed in
    ; A-ZAP. A-FOO is not altered.

((A-ZAP) SELECTIVE-DEPOSIT M-FOO (BYTE-FIELD 16. 8) (A-CONSTANT -1))
    ;A-ZAP gets a copy of M-FOO with the high eight
    ; bits and the low eight bits replaced with all ones
    ; (alternatively, it gets a copy of the -1
    ; with the middle 16. bits replaced with
    ; the corresponding bits from M-FOO)
```

## DISPATCH Operations

Four op-codes are defined in CONSLP for dispatching:

```
DISPATCH
DISPATCH-CALL
DISPATCH-XCT-NEXT
DISPATCH-CALL-XCT-NEXT
```

These are provided purely for cosmetic purposes, since the actual dispatch action is controlled by the dispatch table. CONSLP makes no attempt to check that the "correct" op-code is used with a given dispatch table. By convention, the XCT-NEXT versions are used iff the instruction following the dispatch instruction will be executed (N bit not set), and the CALL versions are used if the P bit is set.

To specify the value of the 10-bit "immediate argument" which is loaded into the DISPATCH CONSTANT register, one may use

```
(I-ARG <expression>) ;immediate argument
```



in the dispatch instruction.

There is a special pseudo-op to facilitate use of the DISPATCH CONSTANT to pass a small, constant number as an argument to a subroutine. The form

```
((ARG-CALL FOO) (I-ARG BAR))
```

generates a DISPATCH instruction to a one-word table containing a CALL-type transfer to FOO, and puts BAR in the dispatch constant field of the dispatch instruction. FOO may then use the READ-I-ARG functional source to pick up and act on the argument.

Miscellaneous Function 2 (write into the dispatch memory) is specified by the symbol WRITE-DISPATCH-RAM.

## JUMP Operations

CONSLP defines a large number of names for the various JUMP operations. These are all built out of a logical progression of pieces:

```
<type> <condition> <xct next>
```

The <type> may be either JUMP, CALL, or POPJ, meaning that no bits, the P bit, or the R bit is set. The <condition> may be one of the following:

```
IF-BIT-SET
IF-BIT-CLEAR
EQUAL
NOT-EQUAL
LESS-THAN
GREATER-THAN
GREATER-OR-EQUAL
LESS-OR-EQUAL
IF-PAGE-FAULT
IF-NO-PAGE-FAULT
IF-PAGE-FAULT-OR-INTERRUPT
IF-NO-PAGE-FAULT-OR-INTERRUPT
IF-PAGE-FAULT-OR-INTERRUPT-OR-SEQUENCE-BREAK
IF-NO-PAGE-FAULT-OR-INTERRUPT-OR-SEQUENCE-BREAK
```

If omitted, the <condition> is assumed to be "always". The <xct next>, if present, is XCT-NEXT; its absence denotes the presence of the N bit, which inhibits the instruction after the jump if the jump is successful. The three parts are connected by "-".

Examples of these operations:

```
CALL-LESS-THAN
```

JUMP-LESS-THAN-XCT-NEXT  
 CALL  
 POPJ-IF-BIT-SET  
 CALL-IF-PAGE-FAULT-OR-INTERRUPT  
 CALL-IF-BIT-CLEAR-XCT-NEXT  
 JUMP-XCT-NEXT  
 POPJ-XCT-NEXT

The POPJ-XCT-NEXT operation is not to be confused with POPJ-AFTER-NEXT, which may be used in any instruction to set the POPJ bit.

Jump instructions which perform an arithmetic comparison should have both an A and an M source; the sources are compared. Jump instructions which test a bit should have an M source and a byte specifier for a 1-bit byte to test.

### Functional Sources

The following names are supplied by CONSLP for the various functional sources:

0	READ-I-ARG	The dispatch constant
1	MICRO-STACK-PNTR-AND-DATA	SPCPTR and SPC contents
	MICRO-STACK-POINTER	Byte specifier for bits <28-24>
	MICRO-STACK-DATA	Byte specifier for bits <18-0>
14	MICRO-STACK-PNTR-AND-DATA-POP	Like 1, but pops SPC stack
	MICRO-STACK-POINTER-POP	Like 1, but pops SPC stack
	MICRO-STACK-DATA-POP	Like 1, but pops SPC stack
2	PDL-BUFFER-POINTER	PDL-pointer register
3	PDL-BUFFER-INDEX	PDL-index register
5	C-PDL-BUFFER-INDEX	PDL-buffer addressed by index
25	C-PDL-BUFFER-POINTER	PDL-buffer addressed by pointer
24	C-PDL-BUFFER-POINTER-POP	PDL-buffer addressed by pointer, pop
6	OPC-REGISTER	The OPCs
7	Q-R	Q register
10	VMA	VMA register
11	MEMORY-MAP-DATA	MAP[MD]
12	MEMORY-DATA	MD
13	LOCATION-COUNTER	LC

## Functional Destinations

The following names are provided by CONSLP for functional destinations. Note that some of them are the same names used for sources; CONSLP distinguishes usage by context.

1	LOCATION-COUNTER	LC
2	INTERRUPT-CONTROL	Interrupt Control Register
10	C-PDL-BUFFER-POINTER	Pdl location addressed by PDL POINTER
11	C-PDL-BUFFER-POINTER-PUSH	Push data onto pdl, increment PDL POINTER
12	C-PDL-BUFFER-INDEX	Pdl location addressed by PDL INDEX
13	PDL-BUFFER-INDEX	PDL INDEX register
14	PDL-BUFFER-POINTER	PDL POINTER register
15	MICRO-STACK-DATA-PUSH	Push data onto SPC stack
16	OA-REG-LOW	Next instruction modify, bits <25-0>
17	OA-REG-HI	Next instruction modify, bits <47-26>
20	VMA	VMA register
21	VMA-START-READ	VMA, initiate read cycle
22	VMA-START-WRITE	VMA, initiate write cycle
23	VMA-WRITE-MAP	VMA, MAP[MD] ← VMA
30	MEMORY-DATA	MD register
31	MEMORY-DATA-START-READ	MD, initiate read cycle
32	MEMORY-DATA-START-WRITE	MD, initiate write cycle
33	MEMORY-DATA-WRITE-MAP	MD, MAP[MD] ← VMA

The symbol Q-R may also be used as a destination; it causes an ALU instruction to have its Q control field to be set to "load Q from ALU output"; this is equivalent to specifying LOAD-Q in the instruction. Do not use the output bus shifter in connection with Q-R as a destination!

## Operations Common to All Instructions

The symbol for the POPJ bit is POPJ-AFTER-NEXT.

Miscellaneous Function 3 is denoted by LOW-PC-BIT-SELECTS-HALF-WD.  
(This feature is described in greater detail in an earlier and a later section.)

## Expression Programs in CONSLP

Wherever an expression may be used in CONSLP, the following arcane forms may be used. In particular, the value of a symbol is normally an expression instead of a simple number. Whenever an expression (or a symbol with an expression as its definition) is encountered, it is evaluated according to the following rules:

<number>                      Evaluates to itself.

- (PLUS <exp1> <exp2>) Adds together the two expressions, and combines their properties (such as byte-specifier-ness).
- (DESTINATION-P <exp>) A conditional: if encountered while assembling a destination, returns the value of <exp>, and otherwise NIL.
- (SOURCE-P <exp>) A conditional: if encountered while assembling a source (M or A), returns the value of <exp>, and otherwise NIL.
- (DISPATCH-INSTRUCTION-P <exp>) A conditional: if encountered while assembling a DISPATCH instruction, returns the value of <exp>, and otherwise NIL.
- (JUMP-INSTRUCTION-P <exp>) A conditional: if encountered while assembling a JUMP instruction, returns the value of <exp>, and otherwise NIL.
- (ALU-INSTRUCTION-P <exp>) A conditional: if encountered while assembling an ALU instruction, returns the value of <exp>, and otherwise NIL.
- (BYTE-INSTRUCTION-P <exp>) A conditional: if encountered while assembling a BYTE instruction, returns the value of <exp>, and otherwise NIL.
- (NOT <conditional>) Negation. <conditional> must be one of the above conditionals forms.
- (OR <cond1> ... <condn>) Like a LISP OR, returns the first non-NIL conditional.
- (BYTE-FIELD <size> <pos>) As described earlier, defines a byte with the given size and position from the right.
- (LISP-BYTE <ppss>) As described earlier; if ppss is written in octal, then this is like (BYTE-FIELD ss pp). If <ppss> is not a number, then it is a LISP expression (not a CONSLP expression!), and is evaluated in LISP.
- (BYTE-MASK <byte specifier>) Value is a word which is zero everywhere except for being all ones in the specified byte. This is a kind of conditional, in that it returns NIL if the byte specifier doesn't really specify a byte.

- (BYTE-VALUE <byte specifier> <value>)** Value is a word which is zero everywhere, except that it contains <value> in the specified byte. This is a kind of conditional, in that it returns NIL if the byte specifier doesn't really specify a byte.
- (OA-HIGH-CONTEXT <word>)** Assembles <word> as an instruction, and returns the high half (bits <47-26>), as if for use by the OA register feature (next instruction modify, functional destination 17).
- (OA-LOW-CONTEXT <word>)** Assembles <word> as an instruction, and returns the low half (bits <25-0>), as if for use by the OA register feature (next instruction modify, functional destination 16).
- (FORCE-DISPATCH <exp>)** Returns value of <exp>, but also forces the instruction to be a DISPATCH instruction. A conflict causes an error.
- (FORCE-JUMP <exp>)** Returns value of <exp>, but also forces the instruction to be a JUMP instruction.
- (FORCE-ALU <exp>)** Returns value of <exp>, but also forces the instruction to be an ALU instruction.
- (FORCE-BYTE <exp>)** Returns value of <exp>, but also forces the instruction to be a BYTE instruction.
- (FORCE-DISPATCH-OR-BYTE <exp>)** Returns value of <exp>, but also forces the instruction to be a DISPATCH or BYTE instruction.
- (FORCE-ALU-OR-BYTE <exp>)** Returns value of <exp>, but also forces the instruction to be an ALU or BYTE instruction.
- (I-MEM-LOC <tag>)** Returns the address represented by <tag> in locality I-MEM as a right-justified value.
- (D-MEM-LOC <tag>)** Returns the address represented by <tag> in locality D-MEM as a right-justified value.
- (A-MEM-LOC <tag>)** Returns the address represented by <tag> in locality A-MEM as a right-justified value.
- (M-MEM-LOC <tag>)** Returns the address represented by <tag> in locality M-MEM as a right-justified value.

- (EVAL <lisp exp>) Returns the result of evaluating in LISP the S-expression <exp>.
- (FIELD <name> <value>) Makes a note that the field <name> has been specified, then multiplies together the values of <name> and <value>; if <name> has a LISP CONS-LAP-ADDITIVE-CONSTANT property, this is then added in. (This obscurity is the primitive from which all field specifications are made.)
- (ERROR) Error if this is assembled. Useful in conditionals.

As examples of how conditionals might be used in expressions, consider these definitions (which are similar (but not identical) to the ones actually used in CONSLP):

```
(ASSIGN Q-R (OR (SOURCE-P (FIELD M-SOURCE 7))
                (FORCE-ALU 3)))
```

```
(ASSIGN MEMORY-DATA
  (OR (SOURCE-P (FIELD M-SOURCE 12))
      (FIELD FUNCTIONAL-DESTINATION 30)))
```

```
(ASSIGN MEMORY-DATA-START-WRITE
  (OR (SOURCE-P (ERROR))
      (FIELD FUNCTIONAL-DESTINATION 32)))
```

### Miscellaneous Pseudo-Operations

Several identical words may be assembled consecutively by saying:

```
(REPEAT <count> <word>)
```

The location counter within the current locality may be set by

```
(LOC <value>) ;sets it to <value>
(MODULO <n>) ;advances it to the next multiple of <n>
```

If the MODULO operation is used in A-memory, wastage is avoided by filling in the skipped-over locations with constants.

## CADR Features and Programming Examples

In this section the various features of the CADR machine are examined and discussed in detail. An attempt is made to give some feeling for how each feature fits into the overall structure of the machine, and the purposes for which the feature is intended. Short programming examples using each feature are presented.

### Timing - The N Bit and the POPJ Bit

Because CADR fetches the next instruction at the same time it is executing the current one, by the time the effect of a JUMP or DISPATCH is known the instruction following the JUMP or DISPATCH has already been fetched. Unless suppressed by the N bit, this instruction is executed before the instruction branched to. The effect of this on programming is that one should "code the branch one instruction sooner". The mnemonics CONSLP provides for the various branching operations normally set the N bit, thus doing the straightforward thing at the cost of wasted cycles; one must append "XCT-NEXT" to the mnemonic to clear the N bit and so bum the code.

For example, consider these two pieces of code:

```

((A-FOO) XOR M-BAR A-FOO)           ;XOR M-BAR into A-FOO
(JUMP-IF-BIT-SET MUMBLE MUMBLIFY)   ;branch on MUMBLE bit

(JUMP-IF-BIT-SET-XCT-NEXT MUMBLE MUMBLIFY) ;branch on MUMBLE bit
((A-FOO) XOR M-BAR A-FOO)           ;XOR M-BAR into A-FOO

```

These both perform an XOR and conditionally jump to MUMBLIFY, but the first one wastes a cycle if the JUMP is successful. Notice the convention of "extending" an instruction which is under the influence of an XCT-NEXT to make it more visible.

If a CALL transfer type is executed, the return address saved on the SPC stack depends on the N bit:

```

(CALL THE-SUBROUTINE)                ;call, N bit set
((A-FOO) XOR M-BAR A-FOO)           ;return here after call

(CALL-XCT-NEXT THE-SUBROUTINE)       ;call, N bit clear
((A-ARGUMENT) ADD M-BAZ A-FOO)      ;do this before entering the subroutine
((A-FOO) XOR M-BAR A-FOO)           ;return here after call

```

If the N bit is set, PC+1 is pushed on the SPC stack; otherwise PC+2 is pushed.

The POPJ bit may be set in any instruction. It causes a RETURN transfer, but only after the next instruction has

also been executed:

```
ADD-THREE-WORDS           ;subroutine to add together A-1, A-2, and A-3
    ((M-RESULT) A-1)
    (POPJ-AFTER-NEXT (M-RESULT) ADD M-RESULT A-2)
    ((M-RESULT) ADD M-RESULT A-3)
```

Again, the idea is to specify the desired control "one instruction early".

Consider the following program:

```
START    (JUMP-XCT-NEXT FOO)
         (JUMP-XCT-NEXT BAR)
         ...
FOO      (JUMP-XCT-NEXT FOO)
         ...
BAR      (JUMP-XCT-NEXT BAR)
```

When started at START, it will go into an infinite loop alternately executing FOO and BAR. Effectively it is in two "jump point" loops at the same time!

## Byte Manipulation

By using M location 2 (by convention a source of zeros) with a BYTE instruction, one can clear any bit or field of bits in any A memory location:

```
((A-FOO) DPB M-ZERO A-FOO (BYTE-FIELD 1 31.))           ;clear sign bit
```

It is often convenient to reserve another M memory location to contain -1 (all ones), in order to be able to set bits easily:

```
((A-FOO) DPB M-ONES A-FOO (BYTE-FIELD 1 31.))           ;set sign bit
```

In a similar manner one can write a routine to extend a signed 24-bit number to 32 bits:

```
SIGN-EXTEND                ;extend 24-bit number in M-NUM
    (POPJ-AFTER-NEXT POPJ-IF-BIT-CLEAR M-NUM (BYTE-FIELD 1 23.))
    ((M-NUM) SELECTIVE-DEPOSIT M-NUM (BYTE-FIELD 24. 0) (A-CONSTANT -1))
```

Another way to do this, which doesn't require the use of POPJ, is to use OA modification to select whether the M source is M-ZERO or M-ONES:

```
((OA-REG-HI) (BYTE-FIELD 1 23.) M-NUM)                 ;low M-source bit gets sign
((M-NUM) SELECTIVE-DEPOSIT M-ZERO (BYTE-FIELD 8 24.) A-NUM)
```



This requires that M-ZERO and M-ONES be an even/odd pair.

Normally bytes can only be loaded from an M source. However, it is possible to load a byte from A-memory, provided that it is at one end of the word, by the following trick:

```
(DEF-DATA-FIELD X-FIELD 6 0)
```

```
(DEF-DATA-FIELD ALL-BUT-X-FIELD 32 6)
```

```
((DEST) SELECTIVE-DEPOSIT M-ZERO ALL-BUT-X-FIELD A-FOO)
```

### The Instruction Stream

<<Some new stuff should be written for this>>

### The SPC Stack

The SPC stack is 32 locations long, each location containing 19 bits (plus parity). It is indexed by SPCPTR, a 5-bit up/down counter. It is used primarily as a microcode subroutine return stack, but besides the 14 bits needed to save a microcode PC there are 5 bits for software use, one of which is the bit used for the macroinstruction pair fetch feature mentioned above.

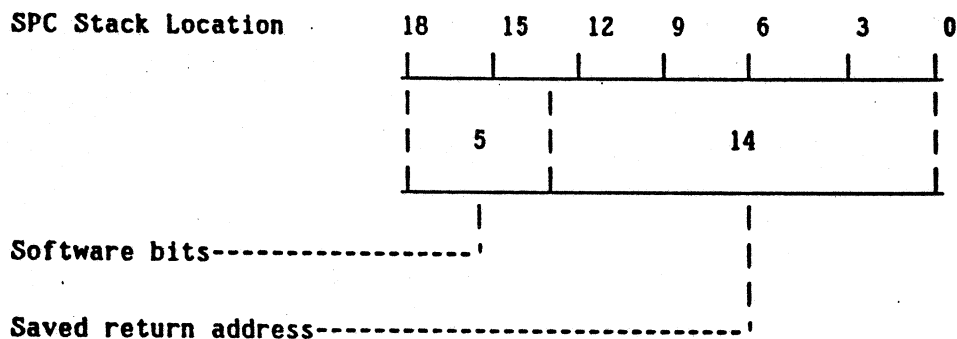

There are two ways in which to write into the SPC stack memory; both of them also increment SPCPTR, thus causing a push operation. A JUMP or DISPATCH performing a CALL transfer type (P bit set, R bit clear) causes a return address to be pushed on the stack as described earlier. The five software bits are set to zero. Writing into functional destination 15 (MICRO-STACK-DATA-PUSH) pushes the low 19 bits of the output bus data onto the SPC stack.

The SPC stack is read by a JUMP or DISPATCH performing a RETURN transfer type (R bit set, P bit clear); the low 14 bits popped off the stack are put in the PC, and the software bits are ignored, except for bit 14 which causes NEXT-INSTR. It

can also be read as M functional sources 1 and 14. The first (MICRO-STACK-PNTR-AND-DATA) merely reads the data (and SPCPTR) on the top of the stack, while the second (MICRO-STACK-PNTR-AND-DATA-POP) pops the stack after reading the data.

There is no way to explicitly set the contents of SPCPTR. However, a good trick is to use the following loop:

```
FOO      ((M-TEMP) MICRO-STACK-POINTER-POP)      ;get just SPCPTR
        (JUMP-IF-EQUAL M-TEMP A-ZERO FOO)
```

A better trick is to use the following loop, which not only is shorter, but is recursive rather than iterative, and has the important advantage of being more obscure:

```
FOO      (CALL-NOT-EQUAL MICRO-STACK-PNTR-AND-DATA
        (A-CONSTANT (PLUS 1 (1-MEM-LOC FOO))) FOO)
```

This is a good thing to do on initialization so that the stack will begin in a known place, thus aiding debugging via the diagnostic interface.

There is no provision for detection of SPC stack overflow or underflow. It is the responsibility of the programmer to avoid nesting subroutines to a depth greater than 32.

## The PDL BUFFER Memory

The PDL BUFFER is intended to be used as a special-purpose cache in the Lisp machine to contain the top portion of the Lisp pushdown stack. It has 1024 locations of 32 bits, and can be indexed by either the PDL POINTER or the PDL INDEX. PDL POINTER is a 10-bit up/down counter, while PDL INDEX is simply a 10-bit register.

The PDL BUFFER is manipulated through various functional sources and functional destinations. The PDL POINTER and PDL INDEX registers may be read and written. (On CONS, these could only be read together, but on CADR they are read separately to facilitate doing arithmetic with them without the need to extract a byte first.) The contents of the PDL BUFFER location addressed by the contents of PDL INDEX may be read and written. The contents of the location addressed by the contents of PDL POINTER may also be read and written, and in this case the PUSH and POP operations may optionally be done by incrementing or decrementing the PDL POINTER. The pointer decrements after reading and increments before writing, so it always points to the topmost valid location.

It doesn't work to specify both C-PDL-BUFFER-POINTER-PUSH and C-PDL-BUFFER-POINTER-POP in the same instruction. On the other hand, the same effect can always be achieved simply by using C-PDL-BUFFER-POINTER for both source and destination instead.

There is no provision for automatic overflow or underflow detection on pushes and pops of the PDL BUFFER. In the Lisp machine, the PDL POINTER is checked on entry to every function, and at a few other necessary places. If there is insufficient room left within the PDL BUFFER for a maximum size frame, some of the PDL BUFFER is stored into main memory to make room. If there is also insufficient space left within the

virtual memory allocated to the PDL, a PDL-OVERFLOW error is signalled. Similarly, the function exit code decides whether to pull some stack back in from main memory.

	REGISTER MEMORY J1	ALU J2	PROGRAM COUNTER J3	INST MEMORY ONE J4	INST MEMORY TWO J5	MAIN MEMORY INTER J6
30	2 2 0 MD	0 0 0	0 0 0	1 2 0 MD	0 0 0	0 0 0
3	4 4 0 MI	0 0 0	0 0 0	4 4 0 MI	0 0 0	0 0 0
7	8 8 0 M2	0 0 0	0 0 0	8 8 0 M2	0 0 0	0 0 0
11	12 12 0 M4	0 0 0	0 0 0	12 12 0 M4	0 0 0	0 0 0
15	16 16 0 M8	0 0 0	0 0 0	16 16 0 M8	0 0 0	0 0 0
19	20 20 0 M16	0 0 0	0 0 0	20 20 0 M16	0 0 0	0 0 0
23	24 24 0 M32	0 0 0	0 0 0	24 24 0 M32	0 0 0	0 0 0
27	28 28 0 M64	0 0 0	0 0 0	28 28 0 M64	0 0 0	0 0 0
31	32 32 0 M128	0 0 0	0 0 0	32 32 0 M128	0 0 0	0 0 0
35	36 36 0 M256	0 0 0	0 0 0	36 36 0 M256	0 0 0	0 0 0
39	40 40 0 M512	0 0 0	0 0 0	40 40 0 M512	0 0 0	0 0 0
43	44 44 0 M1024	0 0 0	0 0 0	44 44 0 M1024	0 0 0	0 0 0
47	48 48 0 M2048	0 0 0	0 0 0	48 48 0 M2048	0 0 0	0 0 0
51	52 52 0 M4096	0 0 0	0 0 0	52 52 0 M4096	0 0 0	0 0 0
55	56 56 0 M8192	0 0 0	0 0 0	56 56 0 M8192	0 0 0	0 0 0
59	60 60 0 M16384	0 0 0	0 0 0	60 60 0 M16384	0 0 0	0 0 0
63	64 64 0 M32768	0 0 0	0 0 0	64 64 0 M32768	0 0 0	0 0 0
67	68 68 0 M65536	0 0 0	0 0 0	68 68 0 M65536	0 0 0	0 0 0
71	72 72 0 M131072	0 0 0	0 0 0	72 72 0 M131072	0 0 0	0 0 0
75	76 76 0 M262144	0 0 0	0 0 0	76 76 0 M262144	0 0 0	0 0 0
79	80 80 0 M524288	0 0 0	0 0 0	80 80 0 M524288	0 0 0	0 0 0
83	84 84 0 M1048576	0 0 0	0 0 0	84 84 0 M1048576	0 0 0	0 0 0
87	88 88 0 M2097152	0 0 0	0 0 0	88 88 0 M2097152	0 0 0	0 0 0
91	92 92 0 M4194304	0 0 0	0 0 0	92 92 0 M4194304	0 0 0	0 0 0
95	96 96 0 M8388608	0 0 0	0 0 0	96 96 0 M8388608	0 0 0	0 0 0
99	100 100 0 M16777216	0 0 0	0 0 0	100 100 0 M16777216	0 0 0	0 0 0
103	104 104 0 M33554432	0 0 0	0 0 0	104 104 0 M33554432	0 0 0	0 0 0
107	108 108 0 M67108864	0 0 0	0 0 0	108 108 0 M67108864	0 0 0	0 0 0
111	112 112 0 M134217728	0 0 0	0 0 0	112 112 0 M134217728	0 0 0	0 0 0
115	116 116 0 M268435456	0 0 0	0 0 0	116 116 0 M268435456	0 0 0	0 0 0
119	120 120 0 M536870912	0 0 0	0 0 0	120 120 0 M536870912	0 0 0	0 0 0
123	124 124 0 M1073741824	0 0 0	0 0 0	124 124 0 M1073741824	0 0 0	0 0 0
127	128 128 0 M2147483648	0 0 0	0 0 0	128 128 0 M2147483648	0 0 0	0 0 0
131	132 132 0 M4294967296	0 0 0	0 0 0	132 132 0 M4294967296	0 0 0	0 0 0
135	136 136 0 M8589934592	0 0 0	0 0 0	136 136 0 M8589934592	0 0 0	0 0 0
139	140 140 0 M17179869184	0 0 0	0 0 0	140 140 0 M17179869184	0 0 0	0 0 0
143	144 144 0 M34359738368	0 0 0	0 0 0	144 144 0 M34359738368	0 0 0	0 0 0
147	148 148 0 M68719476736	0 0 0	0 0 0	148 148 0 M68719476736	0 0 0	0 0 0
151	152 152 0 M137438953472	0 0 0	0 0 0	152 152 0 M137438953472	0 0 0	0 0 0
155	156 156 0 M274877906944	0 0 0	0 0 0	156 156 0 M274877906944	0 0 0	0 0 0
159	160 160 0 M549755813888	0 0 0	0 0 0	160 160 0 M549755813888	0 0 0	0 0 0
163	164 164 0 M1099511627776	0 0 0	0 0 0	164 164 0 M1099511627776	0 0 0	0 0 0
167	168 168 0 M2199023255552	0 0 0	0 0 0	168 168 0 M2199023255552	0 0 0	0 0 0
171	172 172 0 M4398046511104	0 0 0	0 0 0	172 172 0 M4398046511104	0 0 0	0 0 0
175	176 176 0 M8796093022208	0 0 0	0 0 0	176 176 0 M8796093022208	0 0 0	0 0 0
179	180 180 0 M17592186444416	0 0 0	0 0 0	180 180 0 M17592186444416	0 0 0	0 0 0
183	184 184 0 M35184372888832	0 0 0	0 0 0	184 184 0 M35184372888832	0 0 0	0 0 0
187	188 188 0 M70368745777664	0 0 0	0 0 0	188 188 0 M70368745777664	0 0 0	0 0 0
191	192 192 0 M14073749155328	0 0 0	0 0 0	192 192 0 M14073749155328	0 0 0	0 0 0
195	196 196 0 M28147498310656	0 0 0	0 0 0	196 196 0 M28147498310656	0 0 0	0 0 0
199	198 198 0 M56294996621312	0 0 0	0 0 0	198 198 0 M56294996621312	0 0 0	0 0 0
203	199 199 0 M112589993242624	0 0 0	0 0 0	199 199 0 M112589993242624	0 0 0	0 0 0
207	200 200 0 M225179986485248	0 0 0	0 0 0	200 200 0 M225179986485248	0 0 0	0 0 0
211	201 201 0 M450359972970496	0 0 0	0 0 0	201 201 0 M450359972970496	0 0 0	0 0 0
215	202 202 0 M900719945940992	0 0 0	0 0 0	202 202 0 M900719945940992	0 0 0	0 0 0
219	203 203 0 M1801439891881984	0 0 0	0 0 0	203 203 0 M1801439891881984	0 0 0	0 0 0
223	204 204 0 M3602879783763968	0 0 0	0 0 0	204 204 0 M3602879783763968	0 0 0	0 0 0
227	205 205 0 M7205759567527936	0 0 0	0 0 0	205 205 0 M7205759567527936	0 0 0	0 0 0
231	206 206 0 M14411519135054784	0 0 0	0 0 0	206 206 0 M14411519135054784	0 0 0	0 0 0
235	207 207 0 M28823038270109568	0 0 0	0 0 0	207 207 0 M28823038270109568	0 0 0	0 0 0
239	208 208 0 M57646076540219136	0 0 0	0 0 0	208 208 0 M57646076540219136	0 0 0	0 0 0
243	209 209 0 M115292153080438272	0 0 0	0 0 0	209 209 0 M115292153080438272	0 0 0	0 0 0
247	210 210 0 M230584306160876544	0 0 0	0 0 0	210 210 0 M230584306160876544	0 0 0	0 0 0
251	211 211 0 M461168612321753088	0 0 0	0 0 0	211 211 0 M461168612321753088	0 0 0	0 0 0
255	212 212 0 M922337224643506176	0 0 0	0 0 0	212 212 0 M922337224643506176	0 0 0	0 0 0
259	213 213 0 M1844674449287132352	0 0 0	0 0 0	213 213 0 M1844674449287132352	0 0 0	0 0 0
263	214 214 0 M3689348898574264704	0 0 0	0 0 0	214 214 0 M3689348898574264704	0 0 0	0 0 0
267	215 215 0 M7378697797148529408	0 0 0	0 0 0	215 215 0 M7378697797148529408	0 0 0	0 0 0
271	216 216 0 M14757395594297058816	0 0 0	0 0 0	216 216 0 M14757395594297058816	0 0 0	0 0 0
275	217 217 0 M29514791188594117632	0 0 0	0 0 0	217 217 0 M29514791188594117632	0 0 0	0 0 0
279	218 218 0 M59029582377188235264	0 0 0	0 0 0	218 218 0 M59029582377188235264	0 0 0	0 0 0
283	219 219 0 M118059164754376470528	0 0 0	0 0 0	219 219 0 M118059164754376470528	0 0 0	0 0 0
287	220 220 0 M236118329508752941056	0 0 0	0 0 0	220 220 0 M236118329508752941056	0 0 0	0 0 0
291	221 221 0 M472236659017505882112	0 0 0	0 0 0	221 221 0 M472236659017505882112	0 0 0	0 0 0
295	222 222 0 M944473318035011764224	0 0 0	0 0 0	222 222 0 M944473318035011764224	0 0 0	0 0 0
299	223 223 0 M1888946376070023284448	0 0 0	0 0 0	223 223 0 M1888946376070023284448	0 0 0	0 0 0
303	224 224 0 M3777892752140046568896	0 0 0	0 0 0	224 224 0 M3777892752140046568896	0 0 0	0 0 0
307	225 225 0 M7555785504280093137792	0 0 0	0 0 0	225 225 0 M7555785504280093137792	0 0 0	0 0 0
311	226 226 0 M1511157100856018275584	0 0 0	0 0 0	226 226 0 M1511157100856018275584	0 0 0	0 0 0
315	227 227 0 M3022314201712036551168	0 0 0	0 0 0	227 227 0 M3022314201712036551168	0 0 0	0 0 0
319	228 228 0 M6044628403424073102336	0 0 0	0 0 0	228 228 0 M6044628403424073102336	0 0 0	0 0 0
323	229 229 0 M12089256806848146046672	0 0 0	0 0 0	229 229 0 M12089256806848146046672	0 0 0	0 0 0
327	230 230 0 M24178513613696292093344	0 0 0	0 0 0	230 230 0 M24178513613696292093344	0 0 0	0 0 0
331	231 231 0 M48357027227392584186688	0 0 0	0 0 0	231 231 0 M48357027227392584186688	0 0 0	0 0 0
335	232 232 0 M96714054454785168373376	0 0 0	0 0 0	232 232 0 M96714054454785168373376	0 0 0	0 0 0
339	233 233 0 M193428108909570336746752	0 0 0	0 0 0	233 233 0 M193428108909570336746752	0 0 0	0 0 0
343	234 234 0 M386856217819140673493504	0 0 0	0 0 0	234 234 0 M386856217819140673493504	0 0 0	0 0 0
347	235 235 0 M773712435638281346986708	0 0 0	0 0 0	235 235 0 M773712435638281346986708	0 0 0	0 0 0
351	236 236 0 M154742487127656269397344	0 0 0	0 0 0	236 236 0 M154742487127656269397344	0 0 0	0 0 0
355	237 237 0 M309484974255312538794688	0 0 0	0 0 0	237 237 0 M309484974255312538794688	0 0 0	0 0 0
359	238 238 0 M618969948510625077589376	0 0 0	0 0 0	238 238 0 M618969948510625077589376	0 0 0	0 0 0
363	239 239 0 M1237939897021250155178752	0 0 0	0 0 0	239 239 0 M1237939897021250155178752	0 0 0	0 0 0
367	240 240 0 M2475879794042500310357504	0 0 0	0 0 0	240 240 0 M2475879794042500310357504	0 0 0	0 0 0
371	241 241 0 M4951759588085000620715008	0 0 0	0 0 0	241 241 0 M4951759588085000620715008	0 0 0	0 0 0
375	242 242 0 M9903519176170001241430016	0 0 0	0 0 0	242 242 0 M9903519176170001241430016	0 0 0	0 0 0
379	243 243 0 M19807038352340002482860032	0 0 0	0 0 0	243 243 0 M19807038352340002482860032	0 0 0	0 0 0
383	244 244 0 M39614076704680004965720064	0 0 0	0 0 0	244 244 0 M39614076704680004965720064	0 0 0	0 0 0
387	245 245 0 M79228153409360009931440128	0 0 0	0 0 0	245 245 0 M79228153409360009931440128	0 0 0	0 0 0
391	246 246 0 M158456306818720019862880256	0 0 0	0 0 0	246 246 0 M158456306818720019862880256	0 0 0	0 0 0
395	247 247 0 M316912613637440039725760512	0 0 0	0 0 0	247 247 0 M316912613637440039725760512	0 0 0	0 0 0
399	248 248 0 M633825227274880079451521024	0 0 0	0 0 0	248 248 0 M633825227274880079451521024	0 0 0	0 0 0
403	249 249 0 M1267650454549760158903042048	0 0 0	0 0 0	249 249 0 M1267650454549760158903042048	0 0 0	0 0 0
407	250 250 0 M2535300909099520317806084096	0 0 0	0 0 0	250 250 0 M2535300909099520317806084096	0 0 0	0 0 0
411	251 251 0 M5070601818199040635612168192	0 0 0	0 0 0	251 251 0 M5070601818199040635612168192	0 0 0	0 0 0
415	252 252 0 M10141203636398081271224336384	0 0 0	0 0 0	252 252 0 M10141203636398081271224336384	0 0 0	0 0 0
419	253 253 0 M20282407272796162542446672672	0 0 0	0 0 0	253 253 0 M20282407272796162542446672672	0 0 0	0 0 0
423	254 254 0 M40564814545592325084893345344	0 0 0	0 0 0	254 254 0 M40564814545592325084893345344	0 0 0	0 0 0
427	255 255 0 M81129629091184640169787690688	0 0 0	0 0 0	255 255 0 M81129629091184640169787690688	0 0 0	0 0 0
431	256 256 0 M16225925818329280339575379376	0 0 0	0 0 0	256 256 0 M16225925818329280339575379376	0 0 0</	

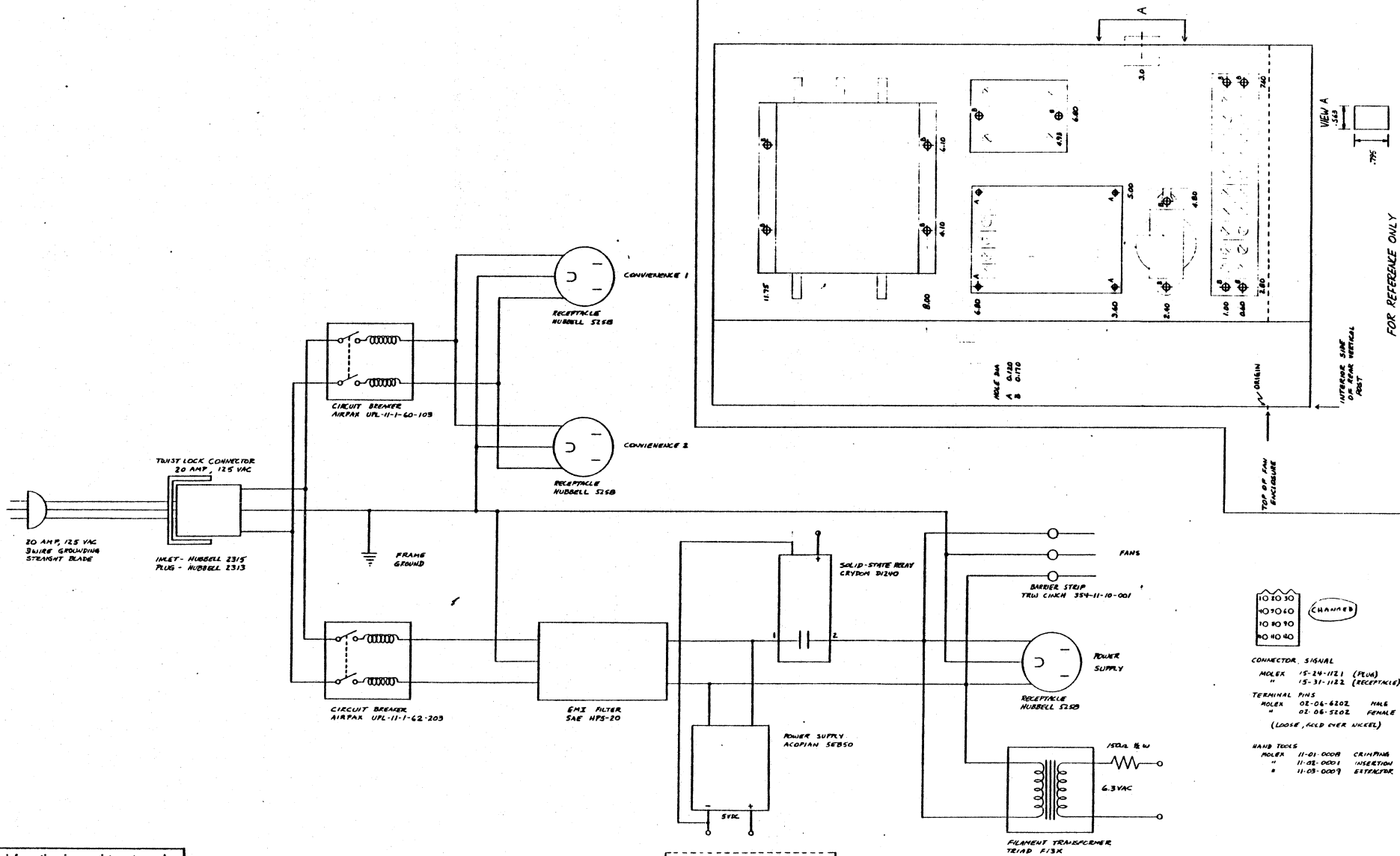

"This data and information is proprietary to, and a valuable trade secret of, SYMBOLICS, INC., a Delaware Corporation. It is given in confidence by SYMBOLICS, and may not be used as the basis of manufacture, or be reproduced or copied, or be distributed to any other party, in whole or in part, without the prior written consent of SYMBOLICS."

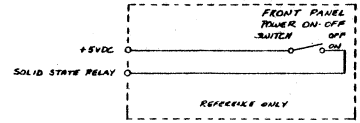

- CONNECTOR, SIGNAL  
 MOLEX 15-24-1121 (PLUG)  
 " 15-31-1122 (RECEPTACLE)  
 TERMINAL PINS  
 MOLEX 02-06-8202 MALE  
 " 02-06-5202 FEMALE  
 (LOOSE, HOLD OVER NICKEL)  
 HAND TOOLS  
 MOLEX 11-01-0009 CRIMPING  
 " 11-02-0001 INSERTION  
 " 11-03-0009 EXTRACTOR

<b>SYMBOLICS, INC.</b>		
SCALE:	APPROVED BY:	DRAWN BY: JVB
NO: 1-9-81		REVISION: 2-13-81
POWER SEQUENCER, Schematic (120VAC)		
DRAWING NUMBER:		101091

FOR REFERENCE ONLY





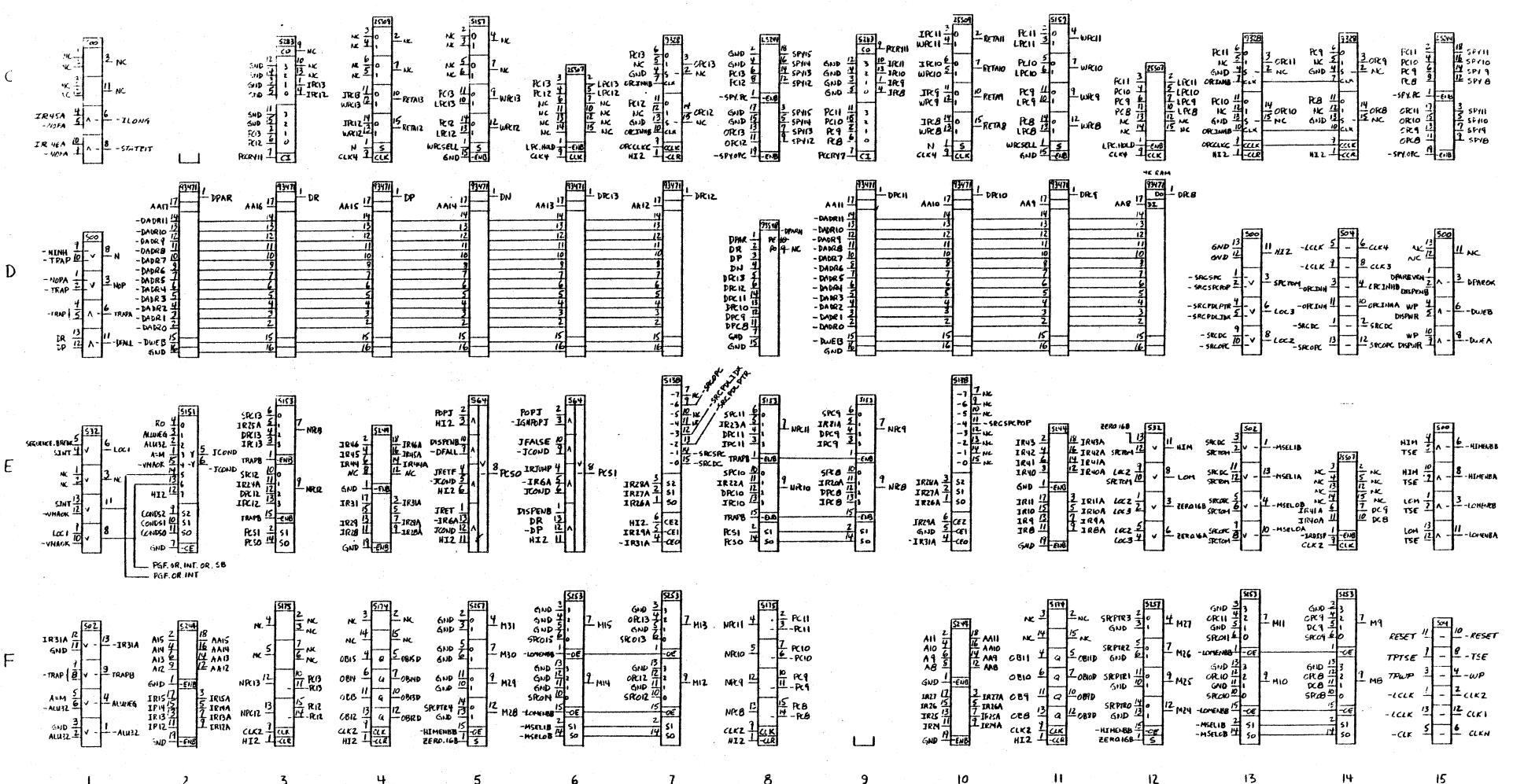

"This data and information is proprietary to, and a valuable trade secret of, SYMBOLICS, INC., a Delaware Corporation. It is given in confidence by SYMBOLICS, and may not be used as the basis of manufacture, or be reproduced or copied, or be distributed to any other party, in whole or in part, without the prior written consent of SYMBOLICS."



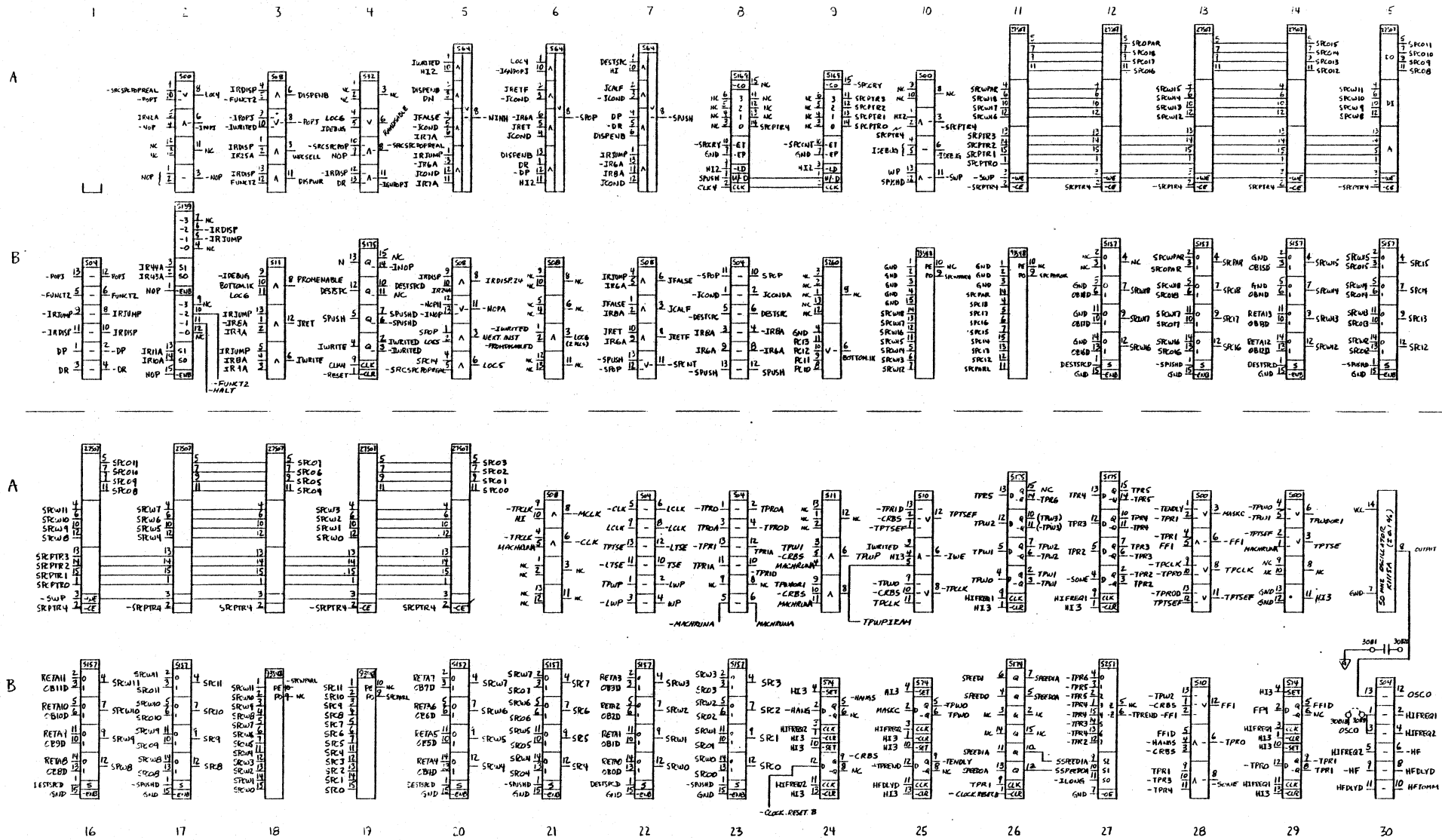

"This data and information is proprietary to, and a valuable trade secret of, SYMBOLICS, INC., a Delaware Corporation. It is given in confidence by SYMBOLICS, and may not be used as the basis of manufacture, or be reproduced or copied, or be distributed to any other party, in whole or in part, without the prior written consent of SYMBOLICS."

SYMBOLICS, INC.

PROGRAM COUNTER Sheet 3 of 3

Schematic 009190 John V. Blankenbaker

November 11, 1980

Rev B

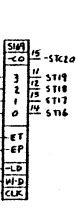
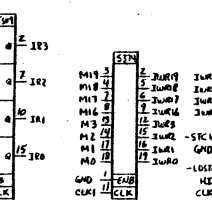
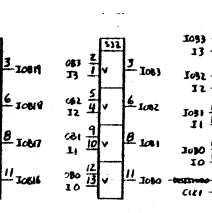
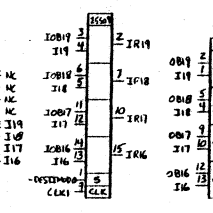
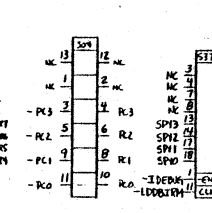
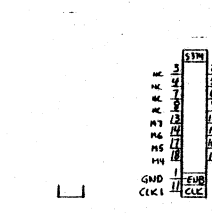
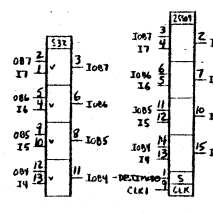
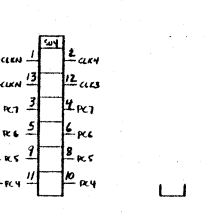
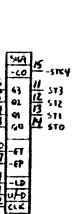
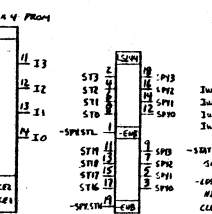
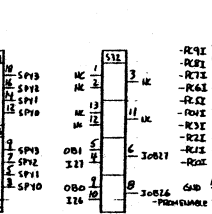
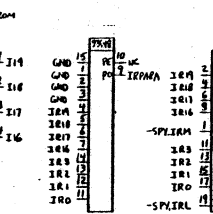
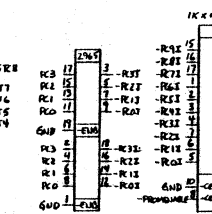
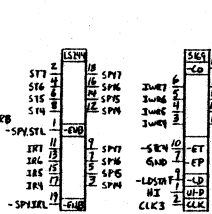
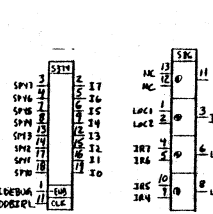
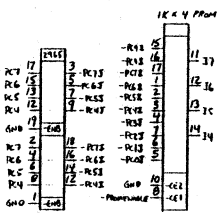
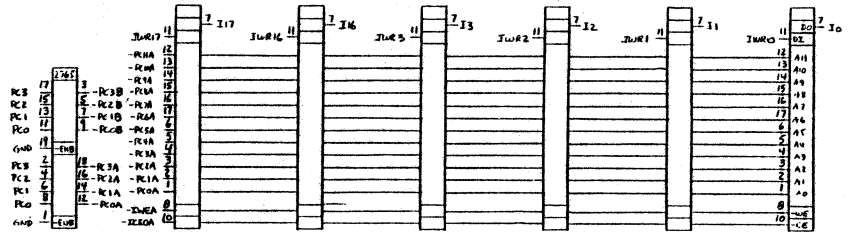
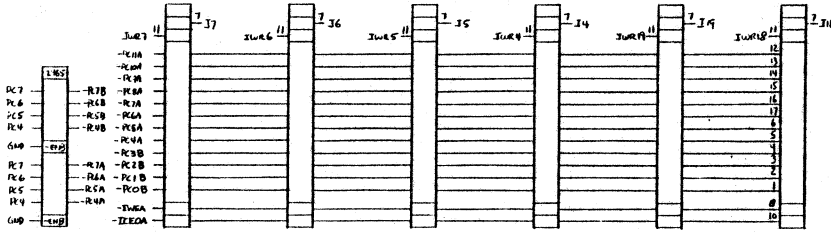
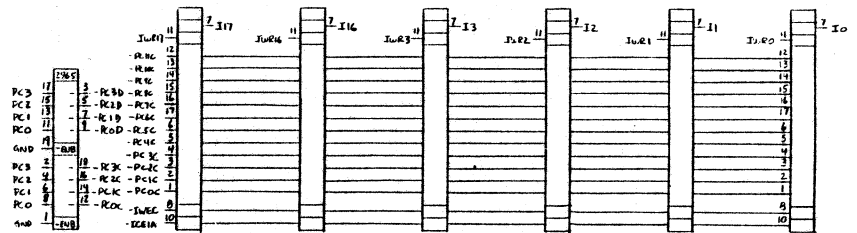
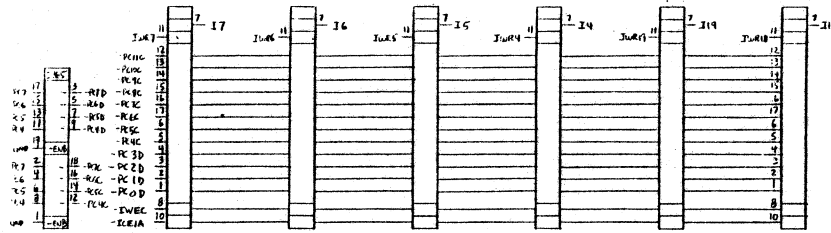

16

17

18

19

20

21

22

23

24

25

26

27

28

29

30

"This data and information is proprietary to, and a valuable trade secret of, SYMBOLICS, INC., a Delaware Corporation. It is given in confidence by SYMBOLICS, and may not be used as the basis of manufacture, or be reproduced or copied, or be distributed to any other party, in whole or in part, without the prior written consent of SYMBOLICS."

SYMBOLICS, INC.

INSTRUCTION MEMORY ONE Sheet 1 of 2

007200 John V. Blankenbaker  
Sept 22, 1980

LOC XXXXXX709



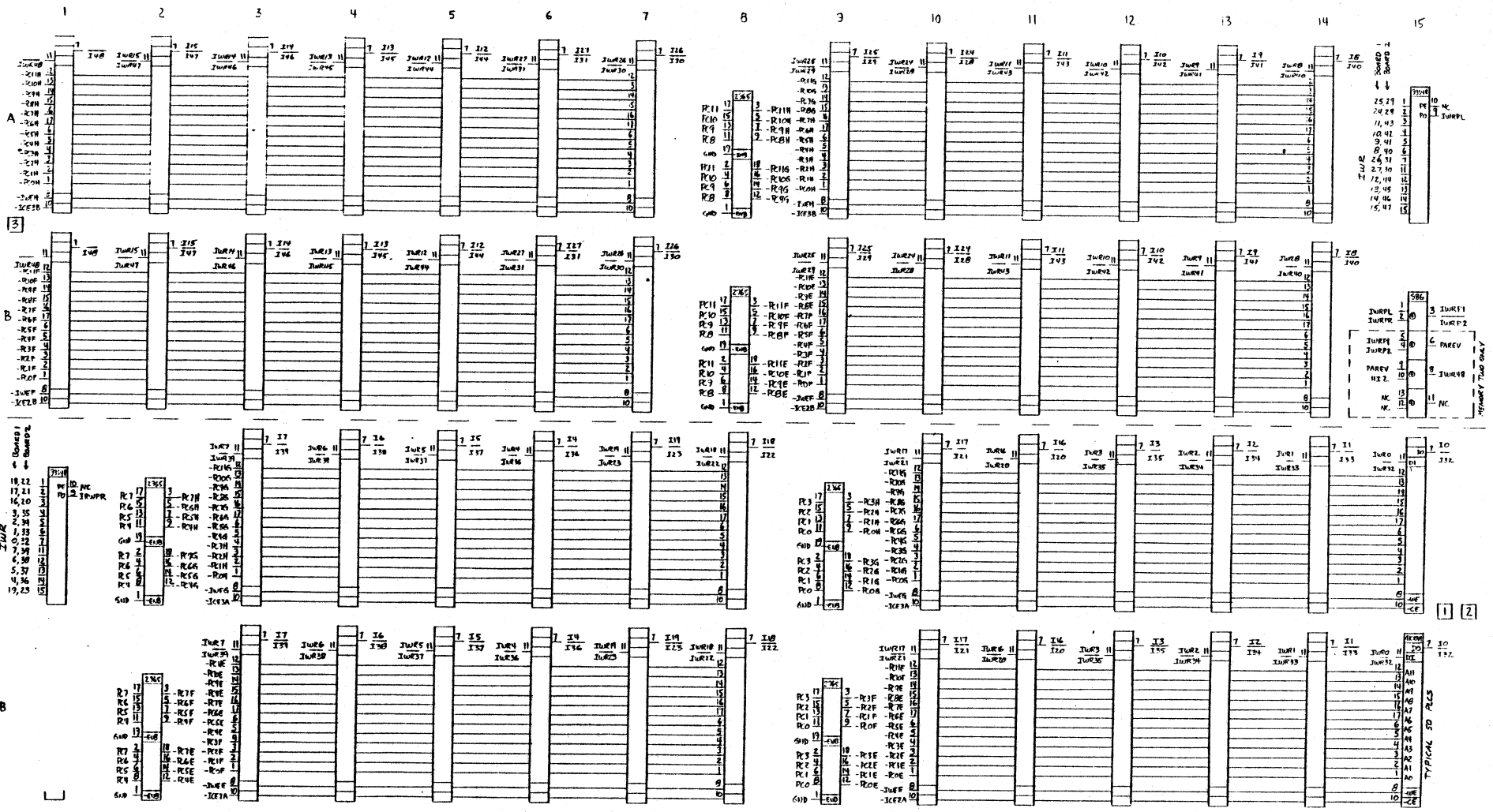

LEFT HALF  
RIGHT HALF

CONNECTOR 22		2A		2B	
PIN	SIGNAL	PIN	SIGNAL	PIN	SIGNAL
1	PCIT	13	PCIT	17	PCIT
2	PCIT	14	PCIT	18	PCIT
3	PCIT	15	PCIT	19	PCIT
4	PCIT	16	-CLKT	20	PCIT
5	PCIT	17	-ERRT		
6	PCIT				
7	PCIT				
8	PCIT				
9	PCIT				
10	PCIT				
11	PCIT				
12	PCIT				

NOTES:  
1 BOARD 1 SIGNAL  
BOARD 2 SIGNAL  
2 4K RAM WITH 2141 PULOUT

"This data and information is proprietary to, and a valuable trade secret of, SYMBOLICS, INC., a Delaware Corporation. It is given in confidence by SYMBOLICS, and may not be used as the basis of manufacture, or be reproduced or copied, or be distributed to any other party, in whole or in part, without the prior written consent of SYMBOLICS."

SYMBOLICS, INC.  
INSTRUCTION MEMORY ONE+TWO, Sheet 3 of 3  
009210 John V. Blumenthaker  
Sept 25, 1980

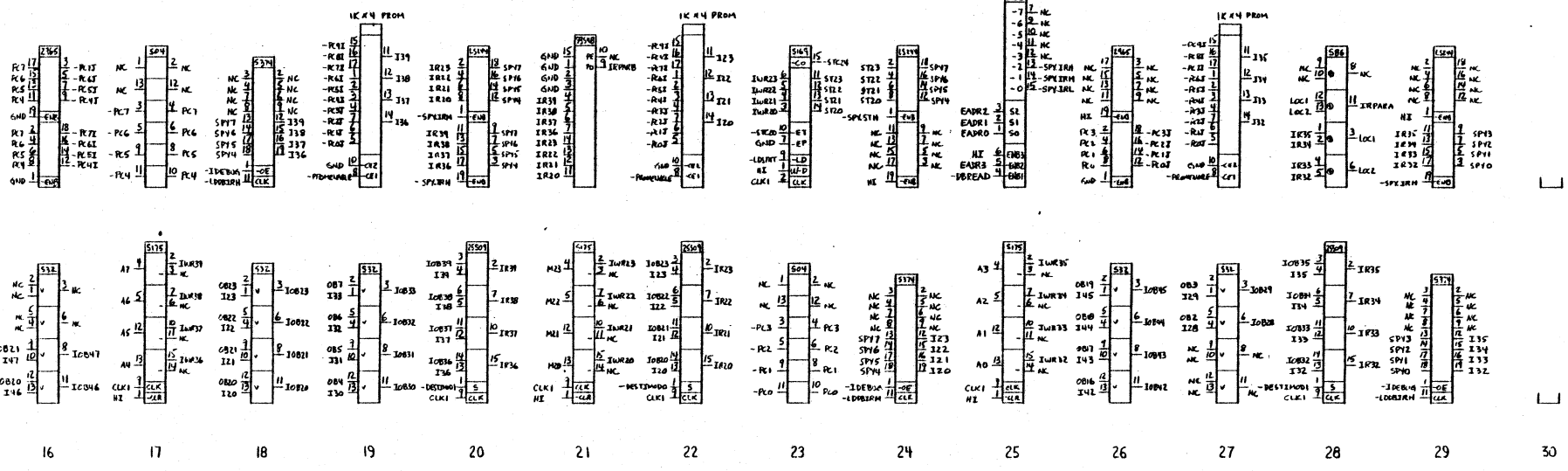
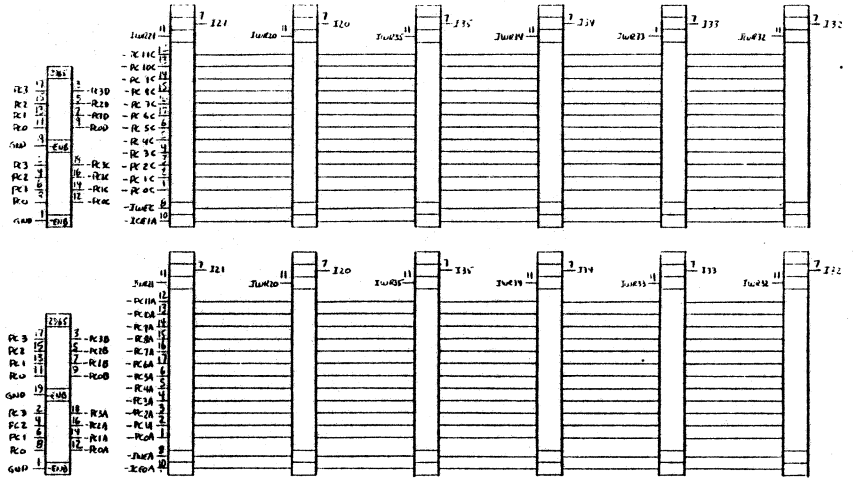
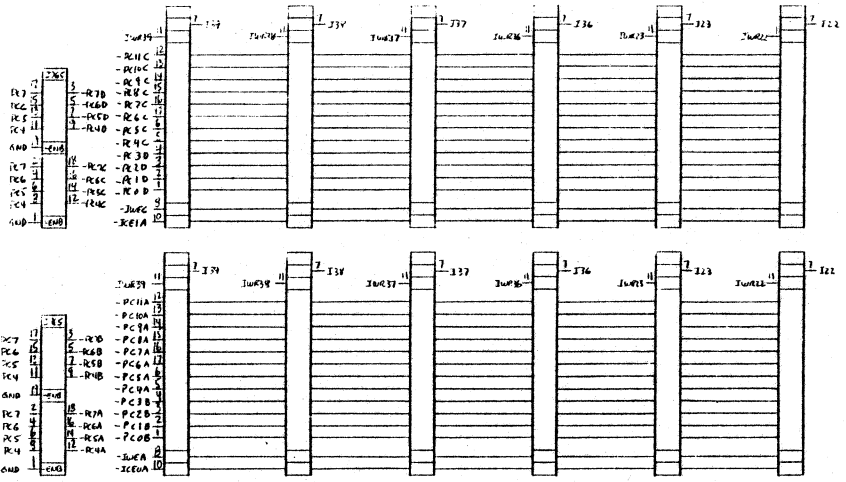

"This data and information is proprietary to, and a valuable trade secret of, SYMBOLICS, INC., a Delaware Corporation. It is given in confidence by SYMBOLICS, and may not be used as the basis of manufacture, or be reproduced or copied, or be distributed to any other party, in whole or in part, without the prior written consent of SYMBOLICS."

SYMBOLICS, INC.  
INSTRUCTION MEMORY TWO, Sheet 1 of 5  
009210 Jan V Blankenbaker  
Sept 25, 1980  
Rev A

Loc 111156789

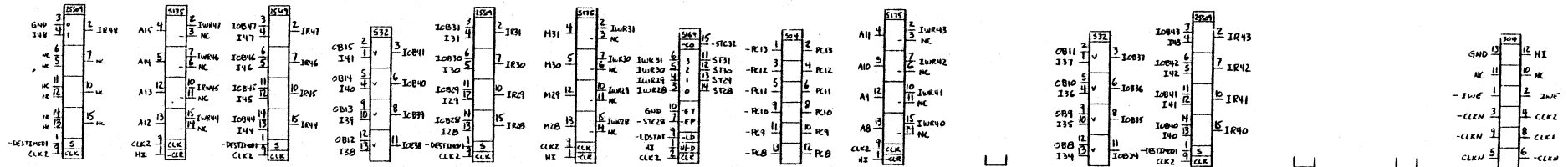
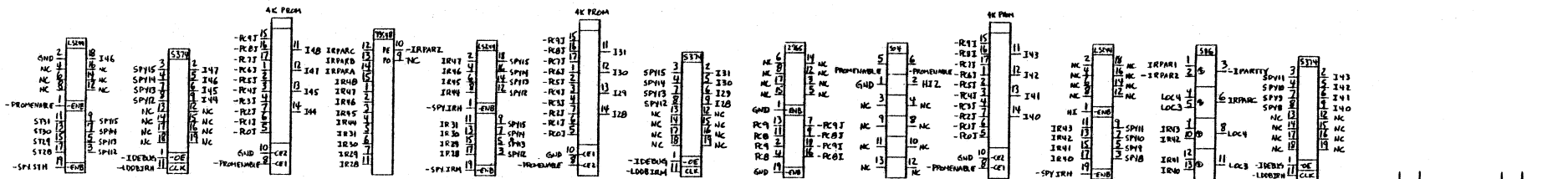
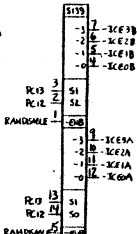
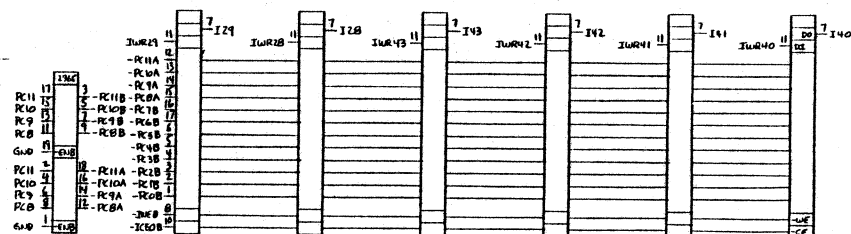
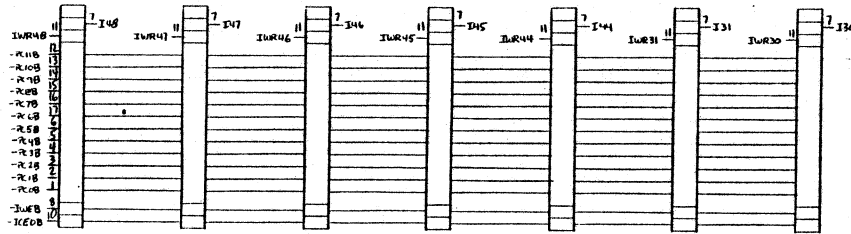
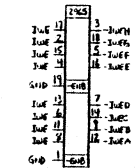
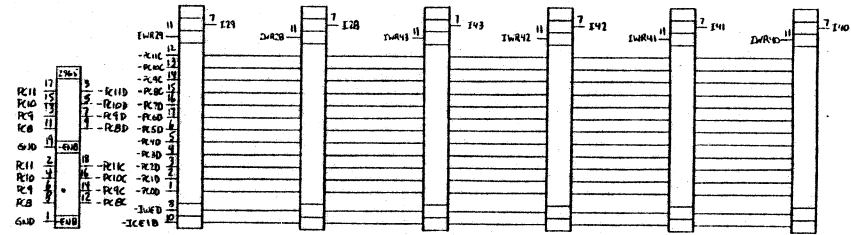
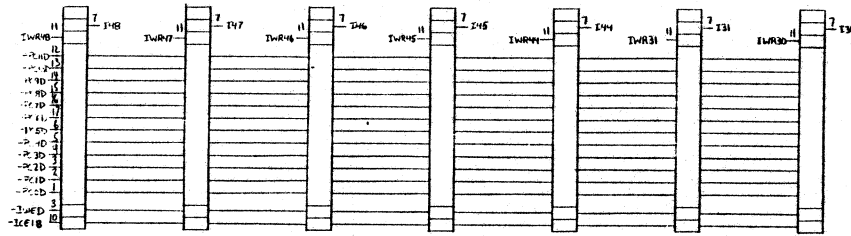

1 2 3 4 5 6 7 8 9 10 11 12 13 14 15

"This data and information is proprietary to, and a valuable trade secret of, SYMBOLICS, INC., a Delaware Corporation. It is given in confidence by SYMBOLICS, and may not be used as the basis of manufacture, or be reproduced or copied, or be distributed to any other party, in whole or in part, without the prior written consent of SYMBOLICS."

SYMBOLICS, INC.  
INSTRUCTION MEMORY TWO, Sheet 2 of 5  
009210 John V. Blankenbaker  
Sept 25, 1980  
Rev A

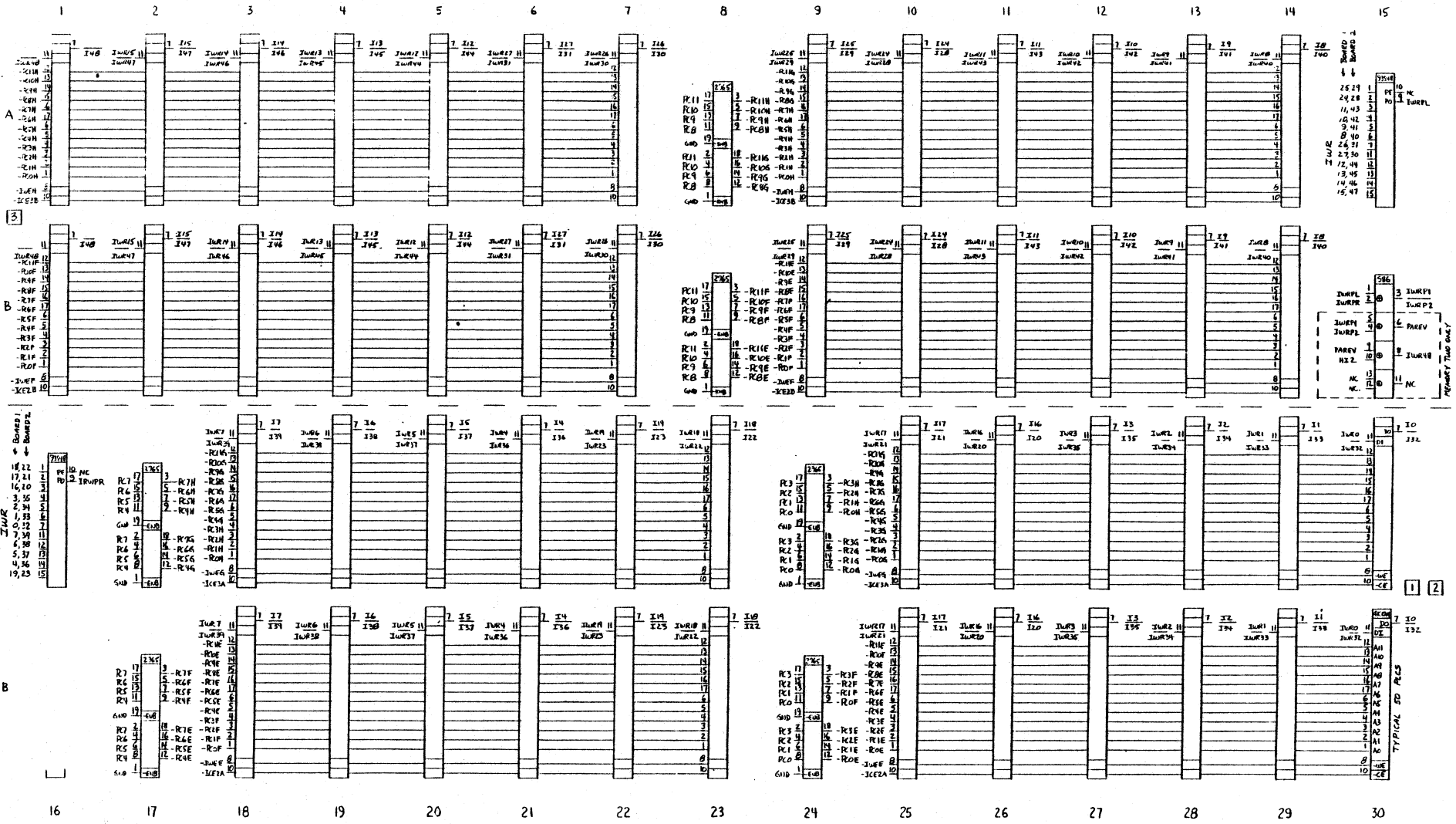

"This data and information is proprietary to, and a valuable trade secret of, SYMBOLICS, INC., a Delaware Corporation. It is given in confidence by SYMBOLICS, and may not be used as the basis of manufacture, or be reproduced or copied, or be distributed to any other party, in whole or in part, without the prior written consent of SYMBOLICS."

CONNECTOR J2		7A		7B	
PIN	SIGNAL	PIN	SIGNAL	PIN	SIGNAL
1	ROT	13	PC1T	17	PC1T
2	PC1T	14	PC1B	18	PC1T
3	PC1T	15	PC1T	19	PC1T
4	PC1T	16	CLKT	20	PC1T
5	PC1T	17	ERR	21	PC1T
6	PC1T	18	ERR	22	PC1T
7	PC1T	19	ERR	23	PC1T
8	PC1T	20	ERR	24	PC1T
9	PC1T			25	PC1T
10	PC1T			26	PC1T
11	PC1T			27	PC1T
12	PC1T			28	PC1T

- NOTES:
- 1 BOARD 1 SIGNAL
  - 2 BOARD 2 SIGNAL

SYMBOLICS, INC.  
INSTRUCTION MEMORY ONE + TWO, Sheet 3 of 3  
009210 John V. Blankenbaker  
Sept 25, 1980

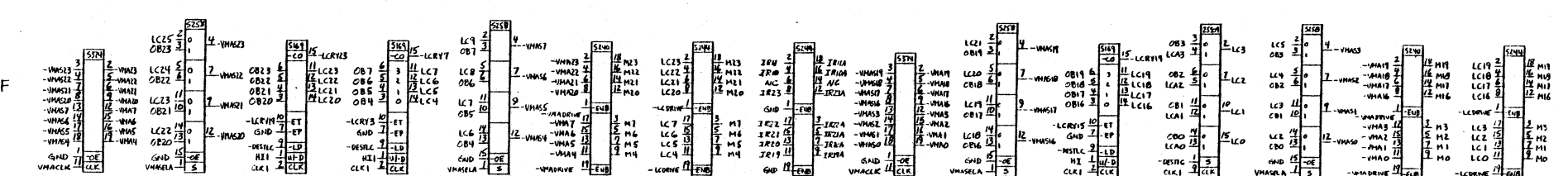
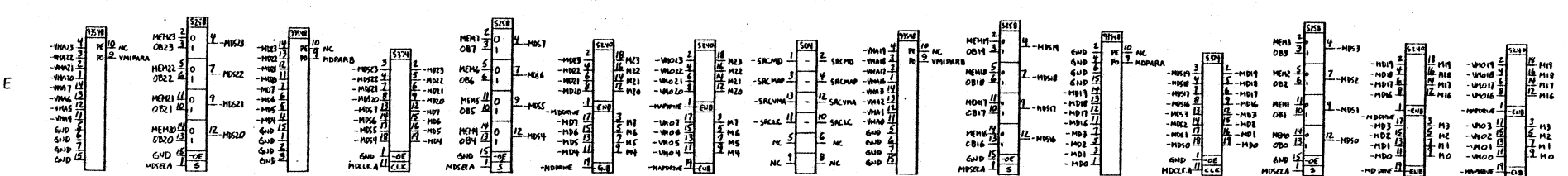
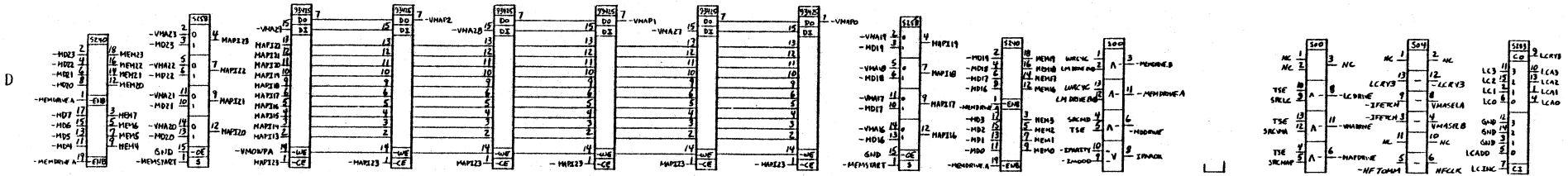
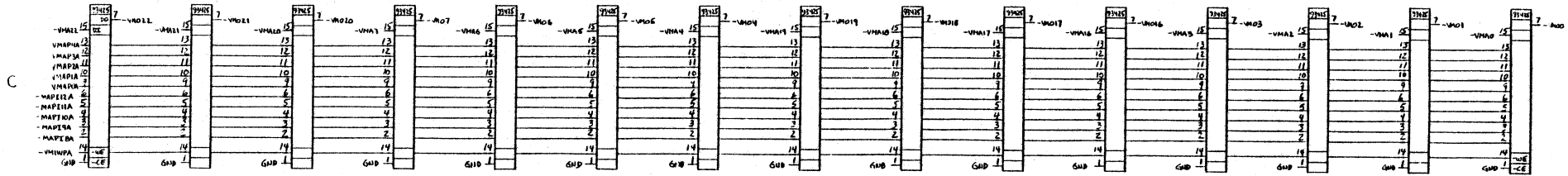

16 17 18 19 20 21 22 23 24 25 26 27 28 29 30

"This data and information is proprietary to, and a valuable trade secret of, SYMBOLICS, INC., a Delaware Corporation. It is given in confidence by SYMBOLICS, and may not be used as the basis of manufacture, or be reproduced or copied, or be distributed to any other party, in whole or in part, without the prior written consent of SYMBOLICS."

NOTE 1. 74502 PINOUTS SHOWN AS BOARD IS BUILT TO U-E 74502 ADAPTOR 15 REQUIRED SEE ZA.6A, 27A, 16B & 30B

ASSY 009222  
PC BD 009221

LOC X X X X X X X X X X

SYMBOLICS, INC  
MAIN MEMORY INTERFACE, Sheet 1 of 3  
Schematic 009220 John V. Blanker Baker  
November 13, 1980  
Rev A









C

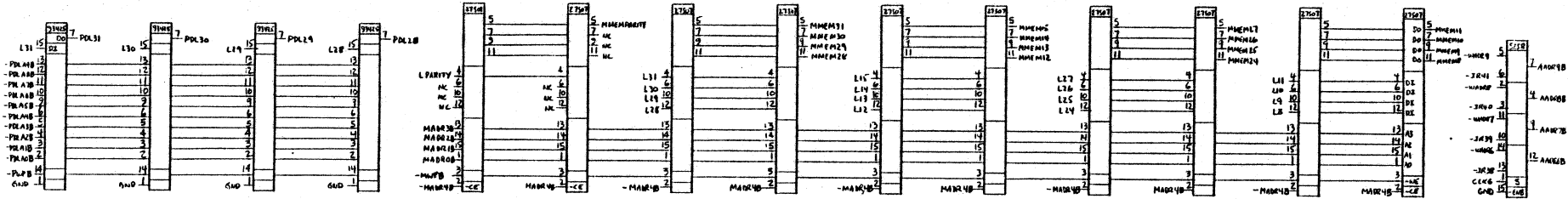

D

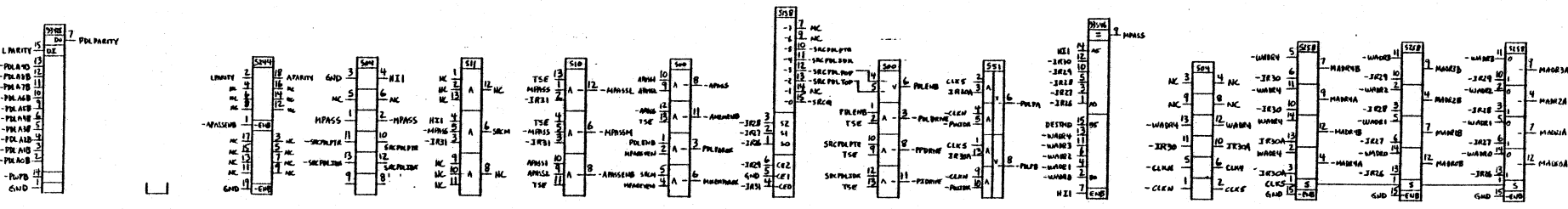

E

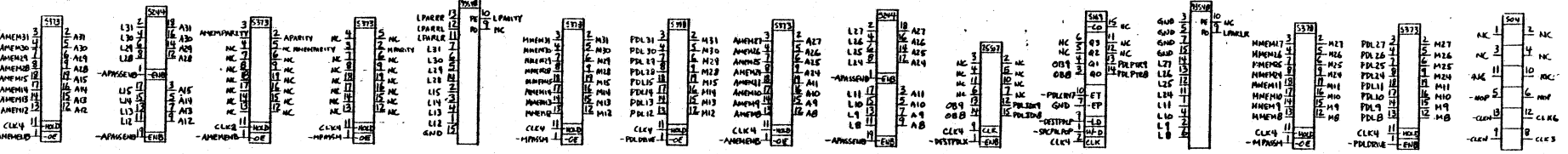

F

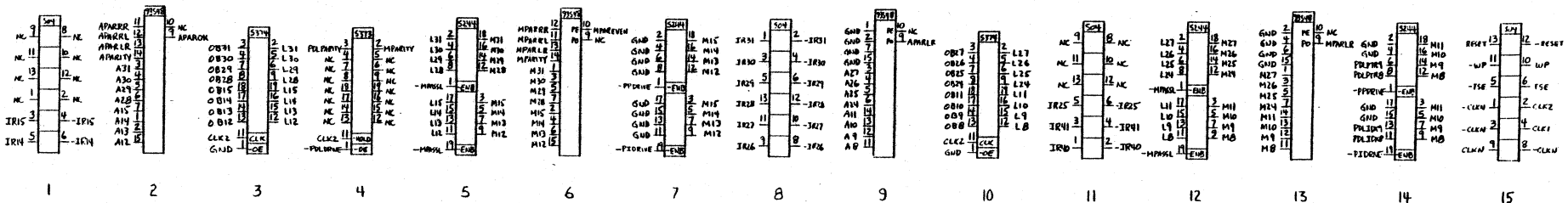

1                      2                      3                      4                      5                      6                      7                      8                      9                      10                      11                      12                      13                      14                      15

"This data and information is proprietary to, and a valuable trade secret of, SYMBOLICS, INC., a Delaware Corporation. It is given in confidence by SYMBOLICS, and may not be used as the basis of manufacture, or be reproduced or copied, or be distributed to any other party, in whole or in part, without the prior written consent of SYMBOLICS."

SYMBOLICS, INC  
 REGISTER MEMORY Sheet 2 of 3  
 Schematic 009170 John V. Blankenbaker  
 October 17, 1980  
 A



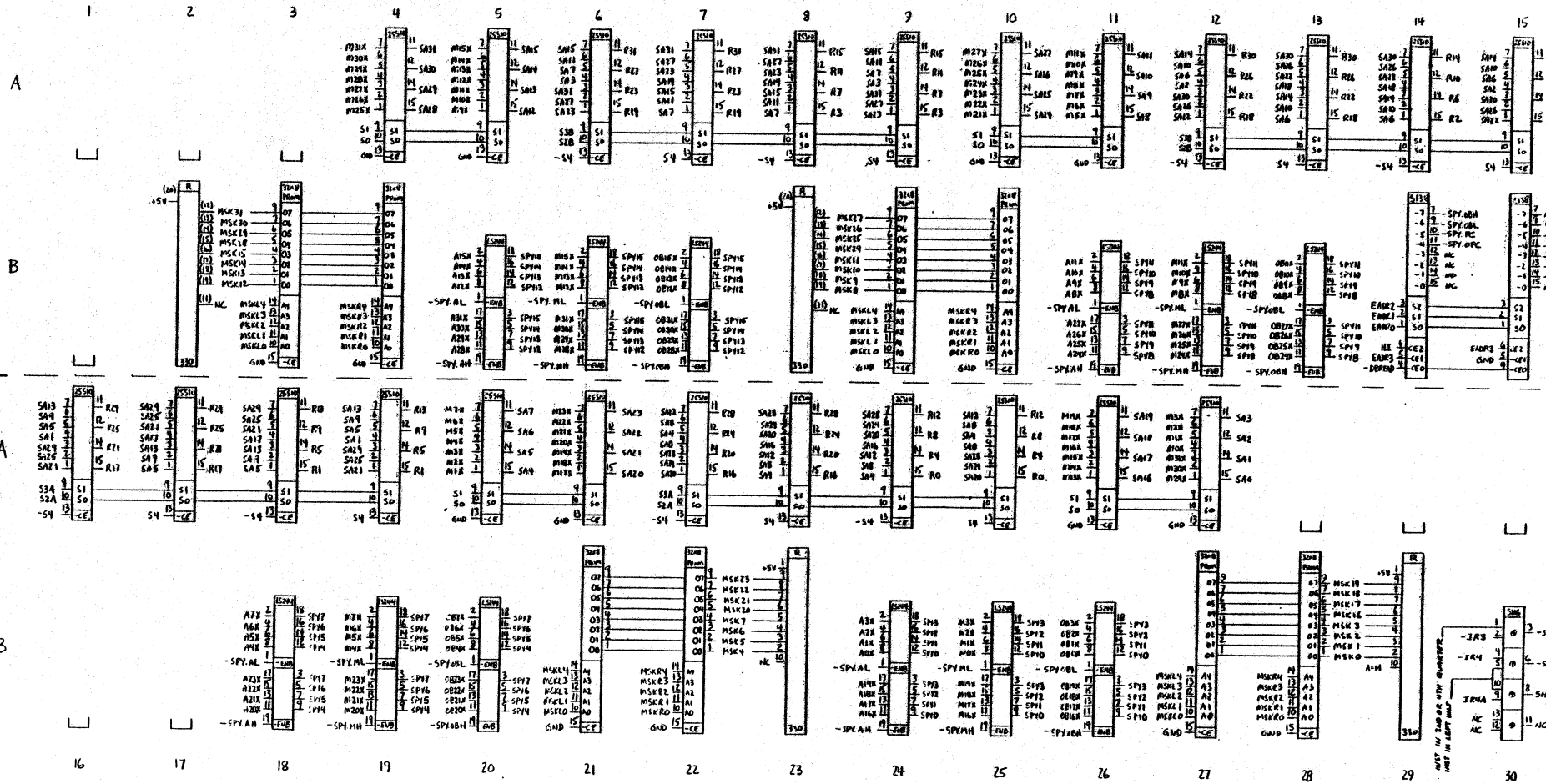

"This data and information is proprietary to, and a valuable trade secret of, SYMBOLICS, INC., a Delaware Corporation. It is given in confidence by SYMBOLICS, and may not be used as the basis of manufacture, or be reproduced or copied, or be distributed to any other party, in whole or in part, without the prior written consent of SYMBOLICS."

SYMBOLICS, INC  
 ARITHMETIC UNIT Sheet 3 of 3  
 Schematic 003180 John V. Blankenship  
 October 6, 1980  
 Rev. A

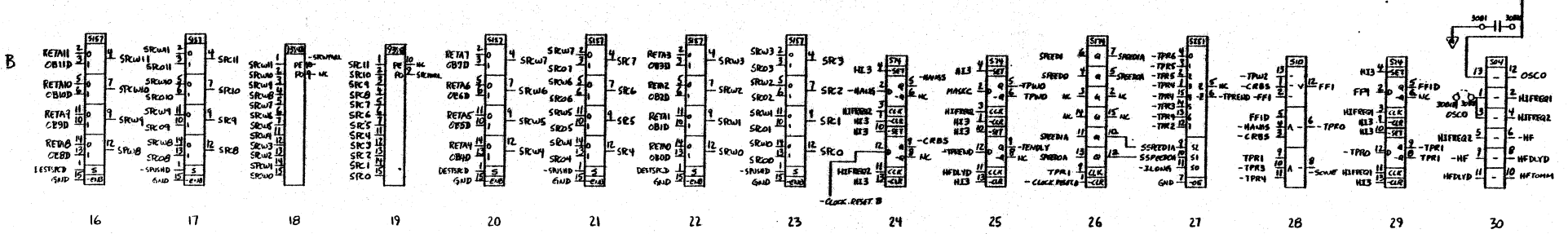
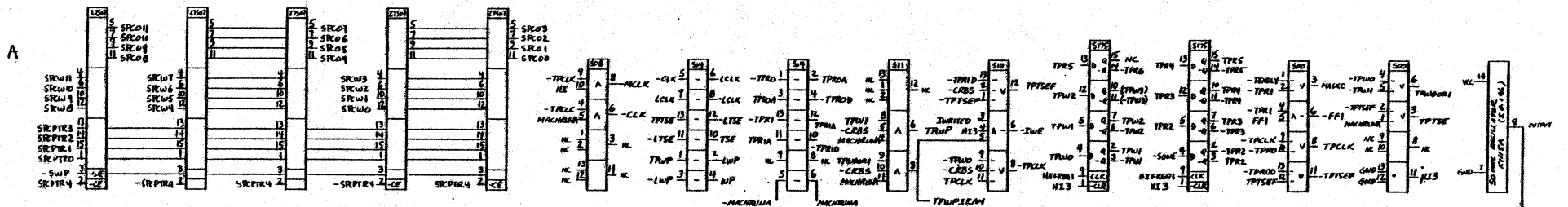
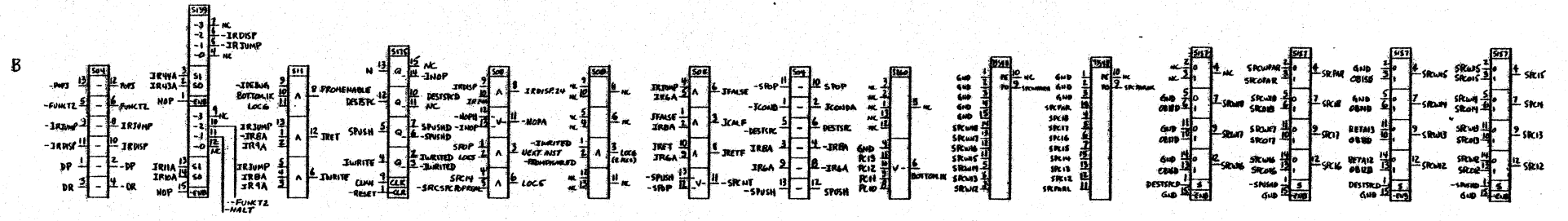
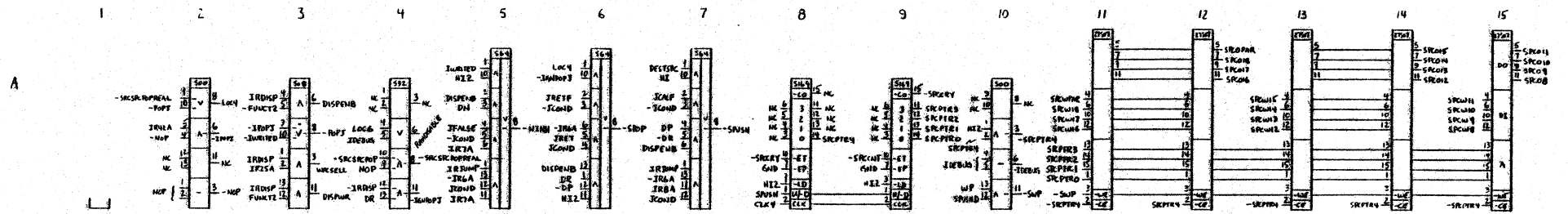

"This data and information is proprietary to, and a valuable trade secret of, SYMBOLICS, INC., a Delaware Corporation. It is given in confidence by SYMBOLICS, and may not be used as the basis of manufacture, or be reproduced or copied, or be distributed to any other party, in whole or in part, without the prior written consent of SYMBOLICS."

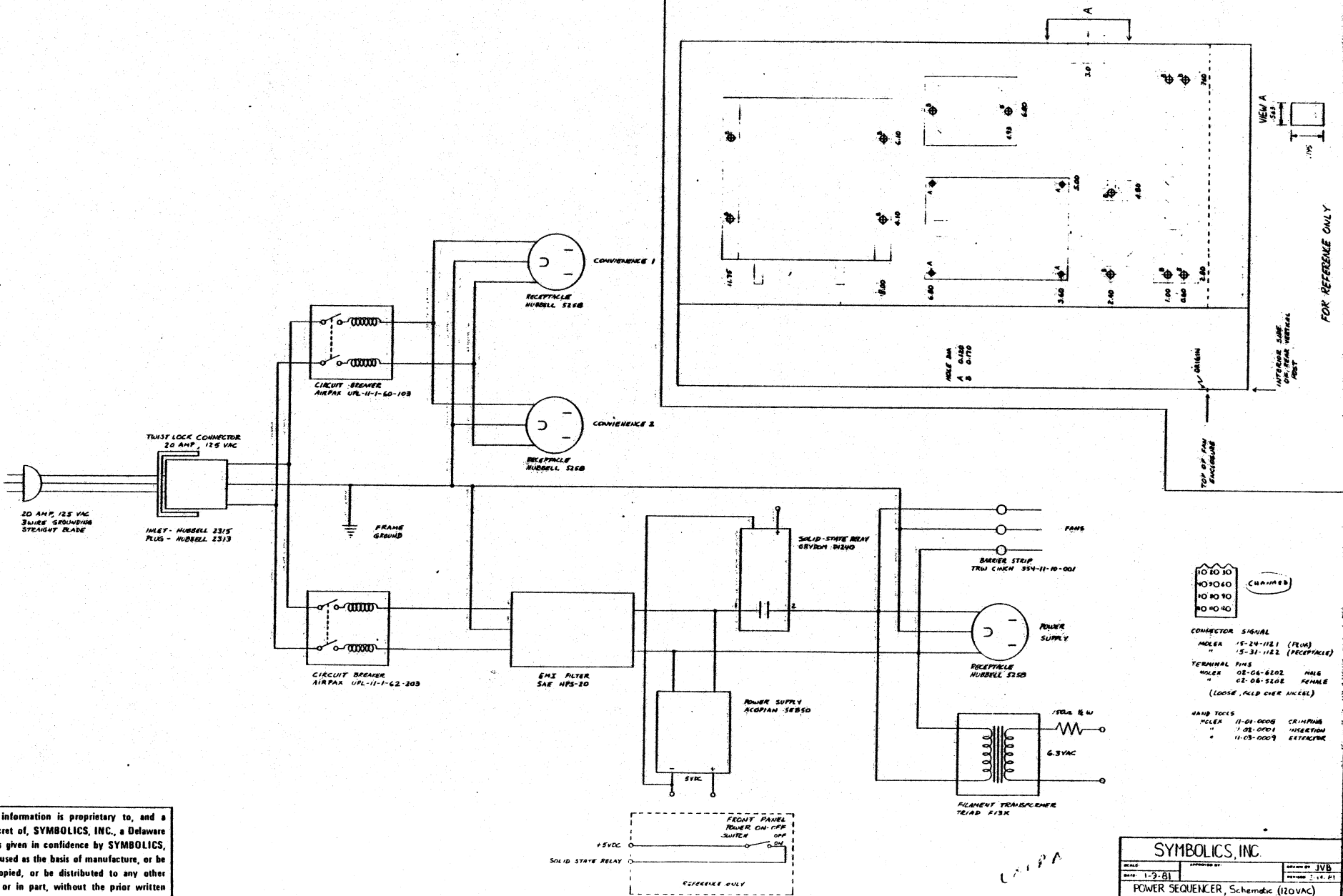

"This data and information is proprietary to, and a valuable trade secret of, SYMBOLICS, INC., a Delaware Corporation. It is given in confidence by SYMBOLICS, and may not be used as the basis of manufacture, or be reproduced or copied, or be distributed to any other party, in whole or in part, without the prior written consent of SYMBOLICS."

SYMBOLICS, INC.		
DATE	APPROVED BY	DESIGNED BY
1-9-81		JVB
POWER SEQUENCER, Schematic (120VAC)		
101091		



The clock can be stopped at the end of either phase, for several reasons. Usually the clock stops at the end of the read phase, referred to as "wait". This leaves the clock in the inactive high state, and leaves the latches on the memories open. The clock can wait because the machine was commanded to halt by the diagnostic interface, because a single-step commanded by the diagnostic interface has completed, because of an error such as a parity error, because of the statistics counter overflowing, or because of a memory-wait condition. This latter condition happens if a main memory cycle is initiated while a previous cycle is still in progress, or if the program calls for the result of a main memory read before the bus controller has granted the bus access needed to perform that read cycle. During a clock wait, the processor clock stops, but the clock to the rest of the system (the bus interface and XBUS devices), continues to run, allowing them to operate. When the processor finishes waiting the processor clock starts up in synchrony with the external clock.

The clock can also stop at the end of the write phase, referred to as "hang". This is used only during memory reads. If the processor calls for the result of a read which is in progress but has not yet completed, it hangs until the data has arrived from memory and sufficient time has passed for the data to flow through the data paths and appear on the output bus. This is also sufficient time for the parity of the data to be checked. In the case of a hang, both clocks stop, which allows them to restart synchronously without any extra delay. In this way, the speed of the processor is adjusted to exactly match the speed of the memory.

#### 4The Bus Interface

The Bus Interface connects the CADR machine to two busses, the Unibus and the Xbus. The Unibus is a regular pdp11 bus, used to attach peripheral devices, especially commercial devices designed for the PDP11 line. The Xbus is a 32-bit bus used to attach memory and high-performance peripheral devices, such as disk. The bus interface also includes the diagnostic interface, which allows a unibus operator, such as a pdp10, a pdp11, or another lisp machine, to control the operation of the machine, hardware to pass interrupts from the Unibus and the Xbus to the processor, the logic which arbitrates the Xbus, and the logic which arbitrates the Unibus in the absence of a pdp11 on that bus.

The Bus Interface allows the CADR machine to access memory on the Xbus and devices on the Unibus, allows independent devices on the Xbus to access the Xbus (only), and allows Unibus devices to access Xbus memory (through a map since the Unibus address space is not big enough.) Buffering is provided when the Unibus accesses the Xbus, to convert a 32-bit word into a pair of 16-bit words.

<<More to come>>

Cover how to program the various frobs from the Unibus, initialization, map structure.

.page  
.sect  
e4The Xbus=0

The Xbus is the standard 32 bit wide data bus for the CADR processor. Main memory and high speed peripherals such as the disk control and TV display are interfaced to the Xbus. Control of the Xbus is similar to the Unibus, in that transfers are positively timed and (as far as the devices are concerned) asynchronous. The bus is terminated at both ends with resistive pullups of 390 ohms to ground and 180 ohms to +5 volts, for an effective 123 ohm termination to +3.42 volts. At ground, each termination draws 28 ma. for a total load of 56 ma. The bus is open collector, and may be driven with any device capable of handling the 56 ma. load. The recommended driver is the AMD 26S10, which also provides bus receivers.

A typical read cycle begins with placing the address for the transfer on the -XADDR lines and the parity of the address on the -XBUS.ADDRPAR line. The -XBUS.RQ line is then lowered, initiating the request. The responding device places the requested data on the 32 -XBUS lines and the parity of the data on the -XBUS.PAR line. Should it not be convenient for the device to produce parity (as in the case of I/O registers), the device may assert -XBUS.IGNPAR to notify the bus master that the transfer should not be checked for correct parity. The responding device then asserts -XBUS.ACK, which remains asserted until the -XBUS.RQ signal is removed by the master.

Write requests proceed identically, except that the master asserts -XBUS.WR and the data to be written on the -XBUS lines along with the address lines. All bus masters are required to produce good parity data on writes.

Deskewing delays are the responsibility of the bus master. In particular, it is the responsibility of the bus master to assert good address, write, and data lines 80 ns. prior to asserting -XBUS.RQ, and these lines must be held until the -XBUS.ACK signal drops in response to the master dropping -XBUS.RQ. Responding devices are allowed to assert -XBUS.ACK at the same time they drive read data onto the -XBUS lines. Thus, masters should delay 50 ns. after receiving -XBUS.ACK before dropping -XBUS.RQ and strobing the data. Responding devices are required to drop -XBUS.ACK immediately after -XBUS.RQ is no longer asserted.

Normal bus master arbitration between the CADR processor and the Unibus requests is handled by the bus interface. Devices on the Xbus which must become bus master, such as the disk control, do so by asserting the -XBUS.EXTRQ signal. When the bus becomes free, the bus interface responds by asserting -XBUS.EXTGRANT. This signal is daisy chained between bus master devices on the Xbus, coming in on the -XBUS.EXTGRANT.IN pin and leaving on the -XBUS.EXTGRANT.OUT pin. Within each device, the decision is made whether or not to pass the grant onto the next device. Unlike the Unibus structure, the decision on whether to pass grant and the act of becoming bus master happen synchronously with a master clock signal distributed on the -XBUS.SYNC line.

When a device initiates a request, it immediately asserts -XBUS.EXTRQ. At the falling edge of -XBUS.SYNC it clocks the request signal into a D flip flop which we will call RFQ.SYNC. When -XBUS.EXTGRANT.IN goes low, the device asserts -XBUS.EXTGRANT.OUT unless it has either the RFQ.SYNC flip flop set, or is already the bus master. At the next falling edge of -XBUS.SYNC the device which has both -XBUS.EXTGRANT.IN and the RFQ.SYNC set becomes bus master. The device should immediately assert -XBUS.BUSY and may immediately begin asserting address lines for a transfer. -XBUS.BUSY may be dropped asynchronously, after the slave device drops -XBUS.ACK in response to the master's request. The -XBUS.EXTGRANT.IN signal must be terminated with a resistive pullup of 180 ohms to +5 volts within each device which does not simply connect it to -XBUS.EXTGRANT.OUT.

#### Signal review:

##### data lines:

-XBUS0 through -XBUS31      32 data lines, low when data is a one  
-XBUS.PAR                    parity of the 32 data lines. Required for writes  
-XBUS.IGNPAR                ignore parity signal, may be asserted by any device for a read

##### address lines:

-XADDR0 through -XADDR21    22 address lines, low for address bit a one  
-XADDR.PAR                  <<this needs to be decided... is this required?>>

##### cycle control lines:

-XBUS.RQ                    Asserted by the master to request a read or write  
Minimum of 80 ns following stable -XADDR, -XBUS.WRITE  
and -XBUS data  
-XBUS.ACK                   Asserted by the slave in response to -XBUS.RQ  
No delay necessary following assertion of good read data  
-XBUS.WR                   Asserted by the master during a write cycle.

##### mastership control lines:

-XBUS.BUSY                  Asserted when a device other than the bus interface  
is bus master. Only the bus interface examines this line.  
Asserted on a -XBUS.SYNC clock edge, dropped asynchronously  
after -XBUS.ACK drops  
-XBUS.EXTRQ                Asserted when a device other than the bus interface  
wishes to become bus master.  
Asserted asynchronously, may be removed asynchronously  
after the device becomes master, but before dropping  
-XBUS.BUSY  
-XBUS.EXTGRANT.IN          The daisy-chained mastership grant signal. Must be pulled  
up with 180 ohms to VCC in the device.  
-XBUS.EXTGRANT.OUT        Asserted initially by the bus interface, synchronously  
with the -XBUS.SYNC edge. The signal may be subject  
to synchronizer lossage, since it is a clocked  
version of -XBUS.EXTRQ which is not synchronous with  
-XBUS.SYNC

##### Miscellaneous:

-XBUS.INIT                  When low, resets all devices. This is low during power  
on and off, and when the machine is reset.  
-XBUS.SYNC                  Synchronization clock for mastership passing and other  
desired purposes.  
Devices become bus master synchronous with the edge of  
this signal. The request will normally follow the  
edge by 80 ns.  
-XBUS.INTR                  Driving this low requests an interrupt.  
All devices are required to initialize to a non-interrupt  
enable condition, and are required to have interrupt

enable and disable bits which can selectively enable interrupts from that device. The "requesting interrupt" state must be readable in one of the device control register bits.

XBUS.POWER.OK

This line is HIGH when power is stable. It remains low for <<xx>> seconds after power comes on, and goes low <<xx>> seconds before power is turned off.

LISPM Bus Interface

\*\*\*\*\* CADR1:BUSINT UML  
\*\*\*\*\* DIP MAP \*\*\*\*\*

25-MAR-81 0822

26S10 XD x	26S10 XD x	74LS244 XBD x	93S48 BUSPAR x	8304 LMDATA x	SIP180/3 LMDATA x
F30	E30	D30	C30	B30	A30
26S10 XD x	26S10 XD x	74LS244 XBD x	93S48 BUSPAR x	8304 LMDATA x	SIP180/3 LMDATA x
F29	E29	D29	C29	B29	A29
26S10 XD x	26S10 XD x	74LS244 XBD x	93S48 BUSPAR x	8304 LMDATA x	SIP180/3 LMDATA x
F28	E28	D28	C28	B28	A28
26S10 XD x	26S10 XD x	74LS244 XBD x	29701 WBUF x	8304 LMDATA x	74LS240 LMADR x
F27	E27	D27	C27	B27	A27
26S10 XA x	26S10 XA x	29701 RBUF x	29701 WBUF x	74LS244 BUSSEL x	74LS240 LMADR x
F26	E26	D26	C26	B26	A26
26S10 XA x	26S10 XA x	29701 RBUF x	29701 WBUF x	74LS244 BUSSEL x	74LS240 LMADR x
F25	E25	D25	C25	B25	A25
26S10 XA x	93S48 XAPAR x	29701 RBUF x	29701 WBUF x	74LS244 BUSSEL x	74LS240 LMADR x
F24	E24	D24	C24	B24	A24
26S10 XA x	93S48 XAPAR x	29701 RBUF x	74LS244 RBUF x	74LS244 BUSSEL x	74LS240 LMADR x
F23	E23	D23	C23	B23	A23
26S10 XA x	74LS244 UBXA x	74LS244 RBUF x	74LS244 RBUF x	8304 DBGOUT x	SIP180/3 DBGIN x
F22	E22	D22	C22	B22	A22
26S10 XA x	74LS244 UBXA x	74LS244 RBUF x	74LS244 BUSSEL x	8304 DBGOUT x	8304 DIAG x
F21	E21	D21	C21	B21	A21
26S10 XD x	74LS244 UBXA x	74S86 REQERR xxxx	74LS244 BUSSEL x	74S00 DATCTL xxxx	8304 DIAG x
F20	E20	D20	C20	B20	A20

LISPM Bus Interface

\*\*\*\*\* CADR1:BUSINT UML  
\*\*\*\*\* DIP MAP \*\*\*\*\*

25-MAR-81 0823

DM8838 UBD x	74LS244 UBD x	74LS244 BUSSEL x	74LS244 BUSSEL x	74S04 DATCTL xxxxxx	74LS374 DBGIN x
F19	E19	D19	C19	B19	A19
DM8838 UBD x	74LS244 UBD x	74LS240 UBINTC x	74S51 DATCTL xx	74S32 DATCTL xxxx	74LS374 DBGIN x
F18	E18	D18	C18	B18	A18
DM8838 UBD x	74LS244 UBMAP x	74LS374 UBINTC x	74S51 DATCTL xx	74S02 DATCTL xxxx	74S241 DBGOUT x
F17	E17	D17	C17	B17	A17
DM8838 UBD x	74LS244 UBMAP x	25LS2519 UBINTC x	74LS244 REQERR x	74S08 REQTIM xxxx	25LS2519 DBGIN x
F16	E16	D16	C16	B16	A16
DM8838 UPRIOR x	29701 UBMAP x	74LS74 UBINTC xx	74S64 DATCTL x	8304 REQERR x	74S139 DBGIN xo
F15	E15	D15	C15	B15	A15
74S38 UPRIOR xxoo	29701 UBMAP x	74LS74 UBINTC xx	74S51 DATCTL xx	74S74 RQSYNCR xx	74S10 DBGIN xxx
F14	E14	D14	C14	B14	A14
74S38 UPRIOR xxxx	29701 UBMAP x	74LS74 UBINTC xx	74S10 RQSYNCR xxx	74S04 XA xxxxxxx	74S04 DBGIN xxxxxx
F13	E13	D13	C13	B13	A13
DM8838 UBA x	29701 UBMAP x	74S133 REQU x	74S260 RQSYNCR xx	74S02 DBGOUT xxxx	74S08 DBGOUT xxxx
F12	E12	D12	C12	B12	A12
DM8838 UBA x	74S258 UBMAP x	74S04 UBA xxxxxx	74S64 REQLM x	74S51 REQLM xx	74S00 DIAG xxxx
F11	E11	D11	C11	B11	A11
DM8838 UBA x	74S258 UBMAP x	74S174 UPRIOR x	74S64 REQLM x	74S74 REQUB xx	MTD100 DBGOUT xoo
F10	E10	D10	C10	B10	A10
DM8838 UBA x	74S08 REQLM xxoo	74S472 UPRIOR x	TD100 REQLM x	TD250 REQUB x	74S32 DBGIN xxxx
F09	E09	D09	C09	B09	A09

LISPM Bus Interface

\*\*\*\*\* CADR1:BUSINT UML  
DIP MAP \*\*\*\*\*

25-MAR-81 0823

DM8838 UBA x	74S133 UBCYC x	25LS2519 UPRIOR x	74S04 REQLM xxxxxx	74S74 UBCYC xx	74S175 RQSYNC x
F08	E08	D08	C08	B08	A08
DM8838 UBMAST x	74S139 UBCYC xx	25LS2519 UPRIOR x	MTD100 REQU xxx	74S04 CLM xxxxxx	74S260 RQSYNC xx
F07	E07	D07	C07	B07	A07
DM8838 UPRIOR x	74S260 UBCYC xx	74S10 UBMAST xxx	74S51 REQUB xx	TD100 RQSYNC x	74S175 RQSYNC x
F06	E06	D06	C06	B06	A06
74S133 UBCYC x	74S04 UBINTC xxxxxx	74S00 UBINTC xxxx	74S20 REQU xo	74S11 RQSYNC xxx	74S02 RQSYNC xxxx
F05	E05	D05	C05	B05	A05
TD260 UBCYC x	74S32 UBINTC xxxx	74S74 UBMAST xx	74S11 DBGIN xxx	74S241 DBGOUT x	74S00 REQU xxxx
F04	E04	D04	C04	B04	A04
74S00 REQU xxxx	74S138 UBCYC x	74LS74 REQU xx	74LS27 UPRIOR xxx	74S04 REQTIM xxxxxx	74LS112 REQERR ox
F03	E03	D03	C03	B03	A03
74S02 REQU xxxx	74S08 UBINTC xxxx	74LS74 UBMAST xx	74LS74 UBMAST xx	74 276 REQERR x	74S288 REQTIM x
F02	E02	D02	C02	B02	A02
TD100 REQU x	74S00 UBMAST xxxx	MTD100 UBMAST xxx	74LS163 UPRIOR x	74LS273 REQTIM x	74LS124 REQTIM xo
F01	E01	D01	C01	B01	A01

LISPM Bus Interface CADR1:BUSINT UML 25-MAR-81 0823 \*\*\*\*\* EDGE CONNECTIONS Flags: (# Output, @ Terminator, ---- Dedicated ground, ++++ Dedicated power) \*\*\*\*\*

Table with 4 columns labeled -A-, -B-, -C-, and -D-. It lists bus connections between various components (A1, B1, C1, D1, E1, F1, H1, J1, K1, L1, M1, N1, P1, R1, S1, T1, U1, V1) and their respective signals (e.g., XBUS35, XBUS5, UB NPG IN, UB BR7 H). The table includes multiple rows of connections and ends with several empty rows.

LISPM Bus Interface CADR1:BUSINT UML 25-MAR-81 0823  
 \*\*\*\*\* EDGE CONNECTIONS Flags: (# Output, @ Terminator, ---- Dedicated ground, ++++ Dedicated power) \*\*\*\*\*  
 -E- -F- -J01- -J02-

A1	A1	01 CLK0	#	01
A2 +5.0V+++++	A2 +5.0V+++++	02 -MEMRQ H	@	02
B1	B1	03 -LM ACK H	#	03
B2 -5.0V	B2 -5.0V	04 LMX GRANT	#	04
C1 -UB ADR12 H	# C1	05 LMUB GRANT	#	05
C2 GND-----	C2 GND-----	06 XBUS REQUEST	#	06
D1 -UB ADR17 H	# D1 -UB BBSY H	# 07 LMUB MASTER	#	07
D2 -UB ADR15 H	# D2	08 C1 OUT	#	08
E1 -UB MSYN H	# E1	09 XWR	#	09
E2 -UB ADR16 H	# E2	10 -FREE H	#	10
F1 -UB ADR2 H	# F1 GND	11 NXM TIMEOUT	#	11
F2 -UB C1 H	# F2	12 -ANY PAR ERROR H	#	12
H1 -UB ADR1 H	# H1	13 ANY GRANT DLYD	#	13
H2 -UB ADR0 H	# H2	14 MSYN IN	#	14
J1 -UB SSYN H	# J1 -UB NPR H	# 15 MSYN OUT	#	15
J2 -UB C0 H	J2	16 SSYN IN	#	16
K1 -UB ADR14 H	# K1	17 SSYN OUT	#	17
K2 -UB ADR13 H	# K2	18 UB REG CYC TO	#	18
L1 -UB ADR11 H	# L1	19 UBXRQ	#	19
L2	L2	20 UBX GRANT	#	20
M1	M1 -UB INTR H	# 21 -DERUG IN REQ H	@	21
M2	M2	22 DEBUG ACK	#	22
N1 GND	# N1 GND	23 DBUB MASTER	#	23
N2 -UB ADR8 H	# N2	24 NC	#	24
P1 -UB ADR10 H	# P1	25 NC	#	25
P2 -UB ADR7 H	# P2	26 -----	#	26 -----
R1 -UB ADR9 H	# R1	27 -----	#	27 -----
R2	R2	28 -----	#	28 -----
S1	S1	29 -----	#	29 -----
S2	S2	30 -----	#	30 -----
T1 GND-----	T1 GND-----	# 31 -----	#	31 -----
T2	T2 -UB SACK H	# 32 -----	#	32 -----
U1 -UB ADR6 H	# U1	33 -----	#	33 -----
U2 -UB ADR4 H	# U2	34 -----	#	34 -----
V1 -UB ADR5 H	# V1	35 -----	#	35 -----
V2 -UB ADR3 H	# V2 LOCAL ENABLE	@ 36 -----	#	36 -----
		37 -----	#	37 -----
		38 -----	#	38 -----
		39 -----	#	39 -----
		40 -----	#	40 -----
		41 -----	#	41 -----
		42 -----	#	42 -----
		43 -----	#	43 -----
		44 -----	#	44 -----
		45 -----	#	45 -----
		46 -----	#	46 -----
		47 -----	#	47 -----
		48 -----	#	48 -----
		49 -----	#	49 -----
		50 -----	#	50 -----



LISPM Bus Interface CADR1:BUSINT UML 25-MAR-81 0823  
\*\*\*\*\* EDGE CONNECTIONS Flags: (# Output, @ Terminator, ---- Dedicated ground, +++ Dedicated power) \*\*\*\*\*

-J03-		-J04-		-J05-		-J06-	
01	01	01	DBD0	#	01	DBD0	#
02	02	02	DBD1	#	02	DBD1	#
03	03	03	DBD2	#	03	DBD2	#
04	04	04	DBD3	#	04	DBD3	#
05	05	05	DBD4	#	05	DBD4	#
06	06	06	DBD5	#	06	DBD5	#
07	07	07	DBD6	#	07	DBD6	#
08	08	08	DBD7	#	08	DBD7	#
09	09	09	DBD8	#	09	DBD8	#
10	10	10	DBD9	#	10	DBD9	#
11	11	11	DBD10	#	11	DBD10	#
12	12	12	DBD11	#	12	DBD11	#
13	13	13	DBD12	#	13	DBD12	#
14	14	14	DBD13	#	14	DBD13	#
15	15	15	DBD14	#	15	DBD14	#
16	16	16	DBD15	#	16	DBD15	#
17	17	17	DEBUG IN A0	@	17	DEBUG OUT A0	#
18	18	18	DEBUG IN A1	@	18	DEBUG OUT A1	#
19	19	19	DEBUG IN WR	@	19	DEBUG OUT WR	#
20	20	20	-DEBUG IN REQ H	@	20	-DEBUG OUT REQ H	#
21	21	21	DEBUG IN ACK	#	21	DEBUG OUT ACK	@
22	22	22	NC	#	22	NC	#
23	23	23	NC	#	23	NC	#
24	24	24	NC	#	24	NC	#
25	25	25	NC	#	25	NC	#
26	26	26	NC	#	26	NC	#
27	27	27	NC	#	27	NC	#
28	28	28	NC	#	28	NC	#
29	29	29	NC	#	29	NC	#
30	30	30	NC	#	30	NC	#
31	31	31	NC	#	31	NC	#
32	32	32	NC	#	32	NC	#
33	33	33	NC	#	33	NC	#
34	34	34	NC	#	34	NC	#
35	35	35	NC	#	35	NC	#
36	36	36	NC	#	36	NC	#
37	37	37	NC	#	37	NC	#
38	38	38	NC	#	38	NC	#
39	39	39	NC	#	39	NC	#
40	40	40	NC	#	40	NC	#
		41	NC	#	41	NC	#
		42	NC	#	42	NC	#
		43	NC	#	43	NC	#
		44	NC	#	44	NC	#
		45	NC	#	45	NC	#
		46	NC	#	46	NC	#
		47	NC	#	47	NC	#
		48	NC	#	48	NC	#
		49	NC	#	49	NC	#
		50	NC	#	50	NC	#

LISPM Bus Interface CADR1:BUSINT UML 25-MAR-81 0823  
 \*\*\*\*\* EDGE CONNECTIONS Flags: (# Output, @ Terminator, ---- Dedicated ground, ++++ Dedicated power) \*\*\*\*\*  
 -J07- -J08- -J09- -J10-

01 SPY0	#01 GND	01 -ADR15 H	01
02 SPY1	#02 -MCLK7 H	@02 -ADR14 H	02
03 SPY2	#03 GND	03 -ADR13 H	03
04 SPY3	#04 GND	04 -ADR12 H	04
05 SPY4	#05 SPY ADR 1	#05 -ADR11 H	05
06 SPY5	#06 SPY ADR 2	#06 -ADR10 H	06
07 SPY6	#07 SPY ADR 3	#07 -ADR9 H	07
08 SPY7	#08 SPY ADR 4	#08 -ADR8 H	08
09 SPY8	#09 -SPY READ H	#09 -ADR7 H	09
10 SPY9	#10 -SPY WRITE H	#10 -ADR6 H	10
11 SPY10	#11 -BUSINT LM RESET H	#11 -ADR5 H	11
12 SPY11	#12 -LM BOOT H	12 -ADR4 H	12
13 SPY12	#13 -LM UNIBUS RESET H	13 -ADR3 H	13
14 SPY13	#14 LM MEMDRIVE ENB	#14 -ADR2 H	14
15 SPY14	#15 -LM POWER RESET H	15 -ADR1 H	15
16 SPY15	#16 NC	#16 -ADR0 H	16
17 -LM GRANT H	#17 NC	#17 -MFMRO H	@17
18 WRCYC	@18 NC	#18 -LM ACK H	#18
19 LM INT	#19 NC	#19 -LOADMD H	#19
20 MEMPAR FROM LM	@20 NC	#20 -LM IGPAR H	#20
21 -----	21 -----	21	21
22 -----	22 -----	22	22
23 -----	23 -----	23	23
24 -----	24 -----	24	24
25 -----	25 -----	25	25
26 -----	26 -----	26	26
27 -----	27 -----	27	27
28 -----	28 -----	28	28
29 -----	29 -----	29	29
30 -----	30 -----	30	30
31 -----	31 -----	31	31
32 -----	32 -----	32	32
33 -----	33 -----	33	33
34 -----	34 -----	34	34
35 -----	35 -----	35	35
36 -----	36 -----	36	36
37 -----	37 -----	37	37
38 -----	38 -----	38	38
39 -----	39 -----	39	39
40 -----	40 -----	40	40
		41 -----	41 -----
		42 -----	42 -----
		43 -----	43 -----
		44 -----	44 -----
		45 -----	45 -----
		46 -----	46 -----
		47 -----	47 -----
		48 -----	48 -----
		49 -----	49 -----
		50 -----	50 -----



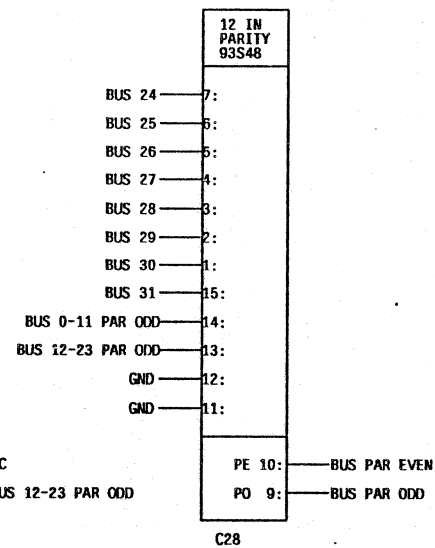
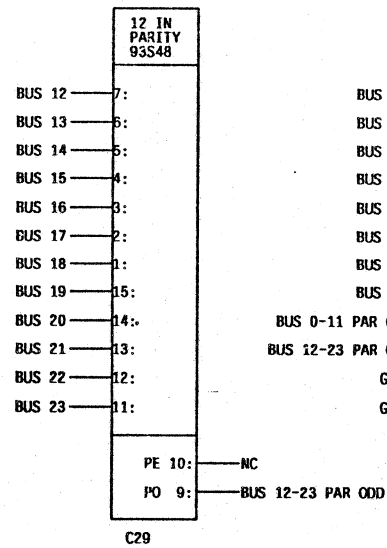
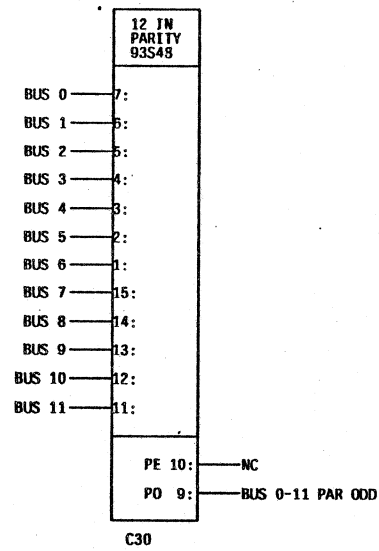

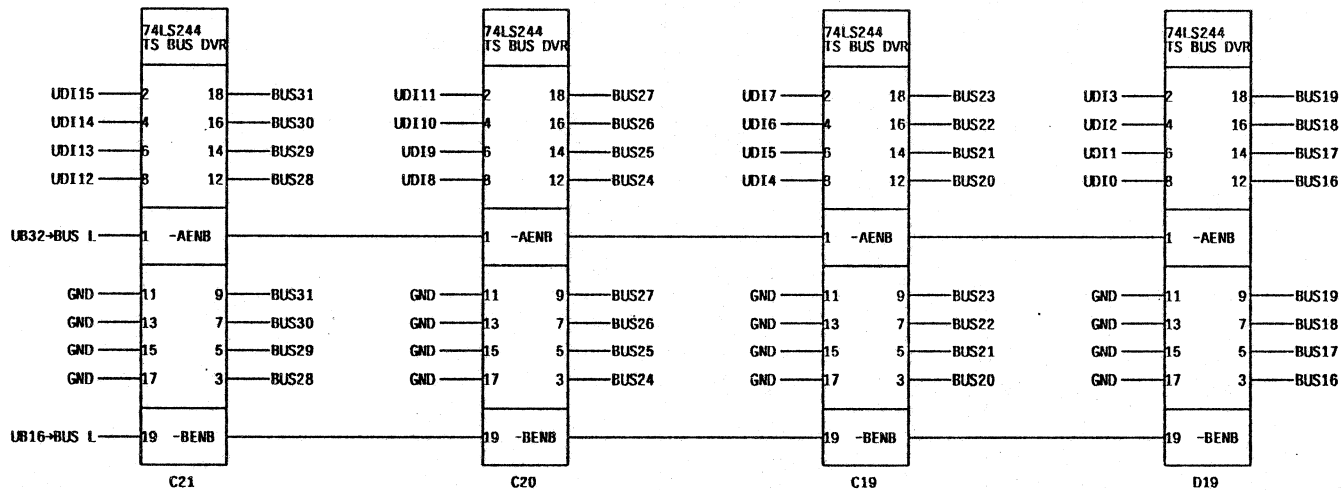
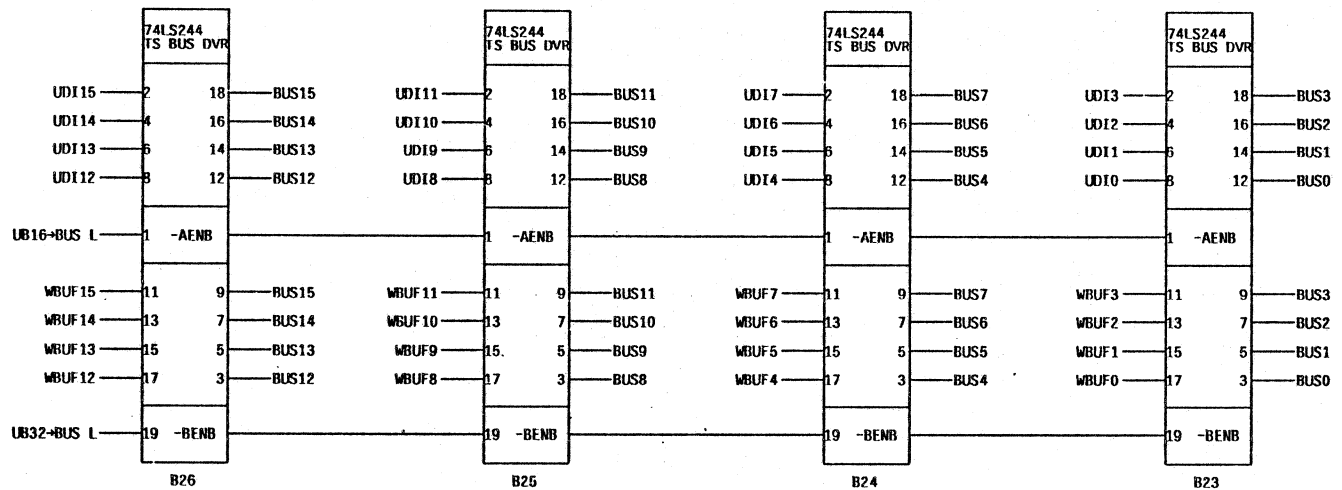

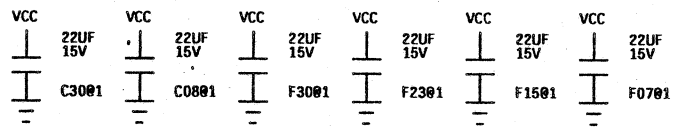

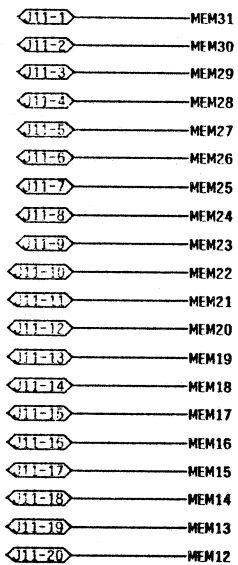

CADR: BCPINS  
to 1AJ1

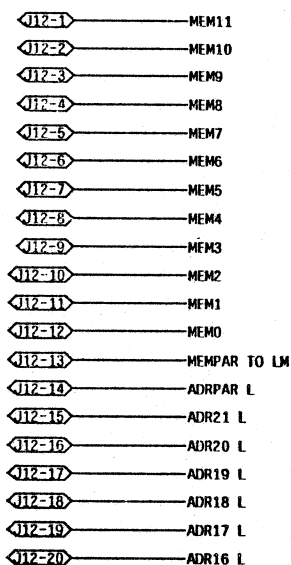

CADR: BCPINS  
to 1BJ1

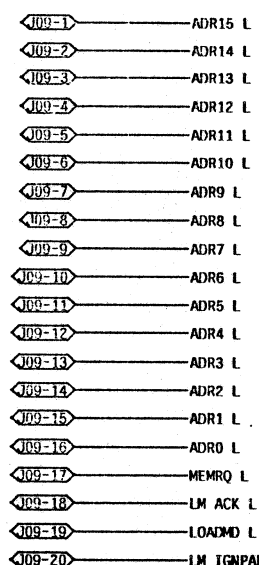

CADR: BCPINS  
to 1CJ1

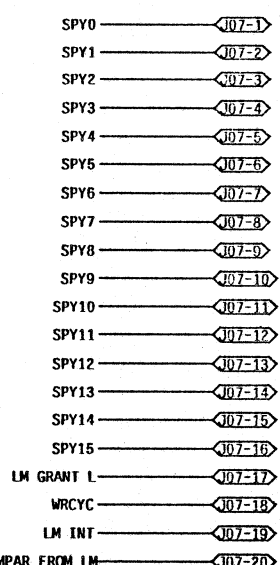

TO 3AJ1  
CADR: BCPINS

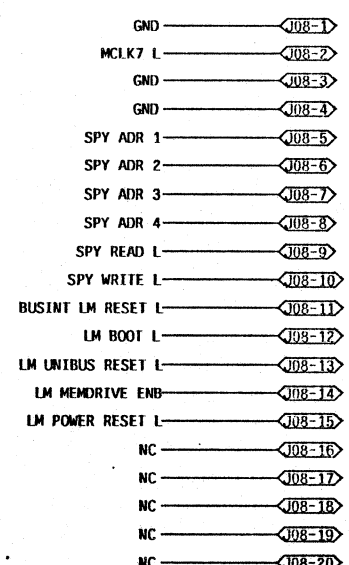

TO 5AJ1  
CADR: MBCPIN

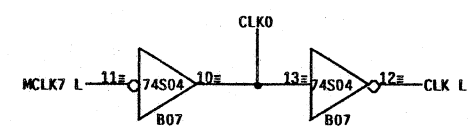
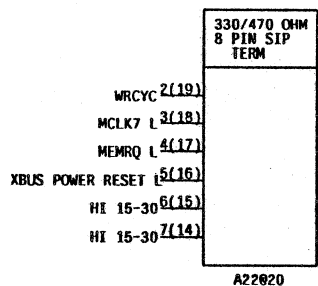

◀J01-1——CLKO  
◀J01-2——MEMRQ L  
◀J01-3——LMACK L  
◀J01-4——LMX GRANT  
◀J01-5——LMUB GRANT  
◀J01-6——XBUS REQUEST  
◀J01-7——LMUB MASTER  
◀J01-8——C1 OUT  
◀J01-9——XWR  
◀J01-10——FREE L  
◀J01-11——NXM TIMEOUT  
◀J01-12——ANY PAR ERROR L  
◀J01-13——ANY GRANT DLYD  
◀J01-14——MSYN IN  
◀J01-15——MSYN OUT  
◀J01-16——SSYN IN  
◀J01-17——SSYN OUT  
◀J01-18——UB REG CYC TO  
◀J01-19——UBXRQ  
◀J01-20——UBX GRANT  
◀J01-21——DEBUG IN REQ L  
◀J01-22——DEBUG ACK  
◀J01-23——DBUB MASTER  
◀J01-24——NC  
◀J01-25——NC



CS2 — UBD0 L

CR2 — UBD1 L

CU2 — UBD2 L

CV2 — UBD3 L

CW2 — UBD4 L

CP2 — UBD5 L

CV2 — UBD6 L

CM2 — UBD7 L

CL2 — UBD8 L

CK2 — UBD9 L

CJ2 — UBD10 L

CH1 — UBD11 L

CH2 — UBD12 L

CF2 — UBD13 L

CF2 — UBD14 L

CD2 — UBD15 L

EV2 — LOCAL ENABLE

CR1 — LM BOOT L

EE1 — UB MSYN L

EJ1 — UB SSYN L

CF2 — UB C0 L

CF2 — UB C1 L

EH2 — UB ADR0 L

EH1 — UB ADR1 L

EF1 — UB ADR2 L

EV2 — UB ADR3 L

EU2 — UB ADR4 L

EV1 — UB ADR5 L

EU1 — UB ADR6 L

EP2 — UB ADR7 L

EN2 — UB ADR8 L

ER1 — UB ADR9 L

EP1 — UB ADR10 L

EL1 — UB ADR11 L

EC1 — UB ADR12 L

EK2 — UB ADR13 L

EK1 — UB ADR14 L

ED2 — UB ADR15 L

EE2 — UB ADR16 L

ED1 — UB ADR17 L

CA1 — UB NPG IN

CH1 — UB NPG OUT

UD2 — UB BR7 L

UE2 — UB BR6 L

UE2 — UB BR5 L

UH2 — UB BR4 L

UL1 — UB INIT L

UK2 — UB BG7 IN

UL2 — UB BG7 IN;(OUT)

UM2 — UB BG6 IN

UM2 — UB BG6 IN;(OUT)

UE2 — UB BG5 IN

UR2 — UB BG5 IN;(OUT)

US2 — UB BG4 IN

UT2 — UB BG4 IN;(OUT)

EU1 — UB BBSY L

EU1 — UB NPR L

EU1 — UB INTR L

ET2 — UB SACK L

AC2 — GND  
 AF1 — GND  
 AN1 — GND  
 AT1 — GND  
 BC2 — GND  
 BF1 — GND  
 BN1 — GND  
 BT1 — GND  
 CC2 — GND  
 CF1 — GND  
 CN1 — GND  
 CT1 — GND  
  
 DP1 — +12V  
 DR1 — +12V  
 DS1 — +12V  
  
 AB2 — -5V  
 BB2 — -5V  
 CB2 — -5V  
 DB2 — -5V  
 EB2 — -5V  
 FB2 — -5V  
  
 AA2 — +5V  
 BA2 — +5V  
 CA2 — +5V  
 DA2 — +5V  
 EA2 — +5V  
 FA2 — +5V

GC2 — GND  
 GF1 — GND  
 GN1 — GND  
 GT1 — GND  
 HC2 — GND  
 HF1 — not grounded  
 for SPC wiring  
 HN1 — GND  
 HT1 — GND  
 IC2 — GND  
 IF1 — GND  
 IN1 — GND  
 IT1 — GND

BE2 — -XBUS PAR  
 BF1 — -XBUS0  
 BG2 — -XBUS1  
 BH1 — -XBUS2  
 BC1 — -XBUS3  
 BD1 — -XBUS4  
 BA1 — -XBUS5  
 AV2 — -XBUS6  
 AV1 — -XBUS7  
 AU2 — -XBUS8  
 AU1 — -XBUS9  
 AT2 — -XBUS10  
 AS2 — -XBUS11  
 AS1 — -XBUS12  
 AR2 — -XBUS13  
 AR1 — -XBUS14  
 AP2 — -XBUS15  
 AP1 — -XBUS16  
 AN2 — -XBUS17  
 AM2 — -XBUS18  
 AM1 — -XBUS19  
 AL2 — -XBUS20  
 AL1 — -XBUS21  
 AK2 — -XBUS22  
 AK1 — -XBUS23  
 AJ2 — -XBUS24  
 AJ1 — -XBUS25  
 AH2 — -XBUS26  
 AH1 — -XBUS27  
 AF2 — -XBUS28  
 AF1 — -XBUS29  
 AE1 — -XBUS30  
 AD2 — -XBUS31  
 AD1 — -XBUS32  
 AC1 — -XBUS33  
 AB1 — -XBUS34  
 AA1 — -XBUS35

BE2 — -XADDR PAR  
 BF2 — -XADDR0  
 BV1 — -XADDR1  
 BU2 — -XADDR2  
 BU1 — -XADDR3  
 BL2 — -XADDR4  
 BS2 — -XADDR5  
 BS1 — -XADDR6  
 BR2 — -XADDR7  
 BR1 — -XADDR8  
 BP2 — -XADDR9  
 BP1 — -XADDR10  
 BR2 — -XADDR11  
 BR2 — -XADDR12  
 BM1 — -XADDR13  
 BL2 — -XADDR14  
 BL1 — -XADDR15  
 BK2 — -XADDR16  
 BK1 — -XADDR17  
 BL2 — -XADDR18  
 BL1 — -XADDR19  
 BH2 — -XADDR20  
 BH1 — -XADDR21

THESE SIGNALS MUST BE  
 JUMPED OVER TO CORRESPONDING  
 XBUS RUNS

TO CD2 — CC1 — -XBUS RQ  
 TO CE2 — CD1 — -XBUS ACK  
 TO CF2 — CE1 — -XBUS WR  
 TO CH2 — CJ1 — -XBUS IGP PAR  
 TO CJ2 — CK1 — -XBUS INIT  
 TO CK2 — CL1 — -XBUS EXTRQ  
 TO CL2 — CM1 — -XBUS BUSY  
 TO CM2 — CP1 — -XBUS SYNC  
 TO CP2 — CS1 — -XBUS INTR  
  
 TO CH1 — CV1 — -XBUS EXTGRANT OUT  
 — -XBUS POWER OK  
 — -XBUS POWER RESET L

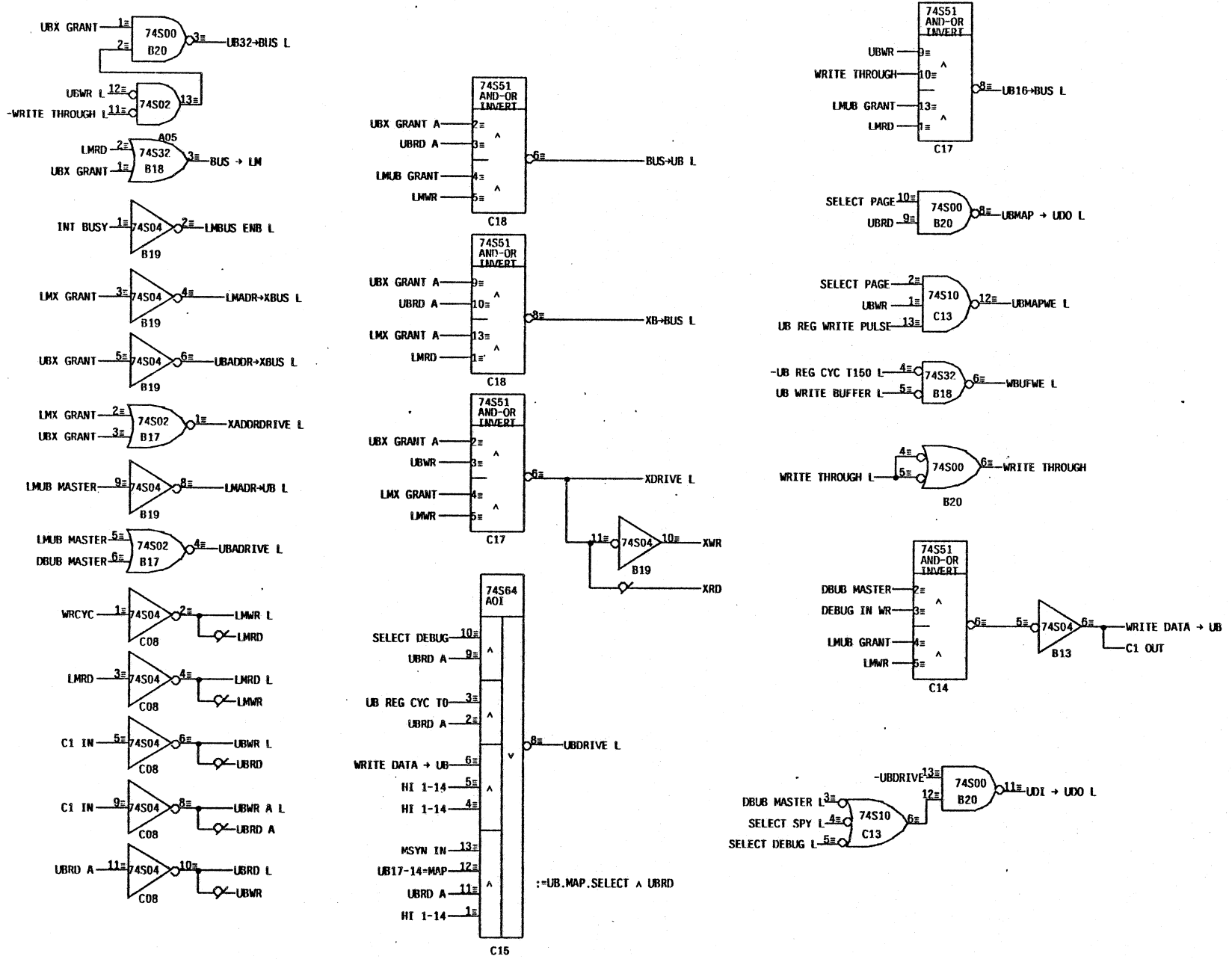

- DBD0
- DBD1
- DBD2
- DBD3
- DBD4
- DBD5
- DBD6
- DBD7
- DBD8
- DBD9
- DBD10
- DBD11
- DBD12
- DBD13
- DBD14
- DBD15
- DEBUG IN A0
- DEBUG IN A1
- DEBUG IN WR
- DEBUG IN REQ L
- DEBUG IN ACK
- NC
- NC
- NC
- NC

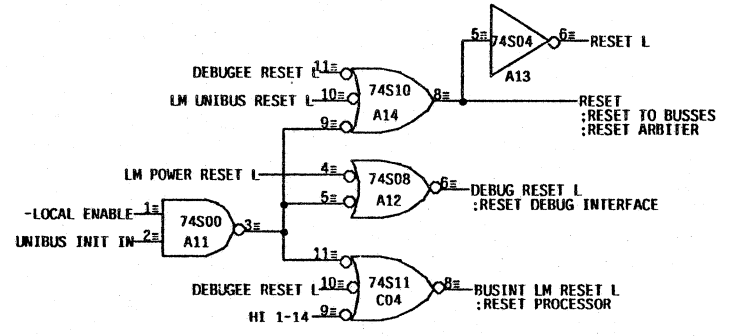
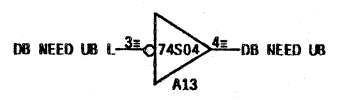
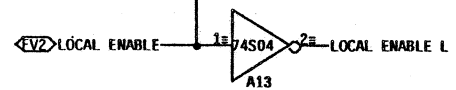
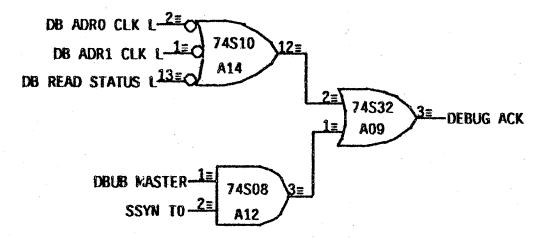
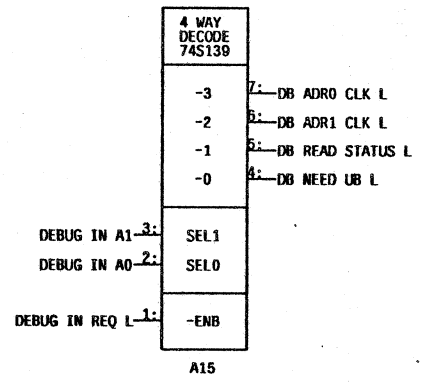
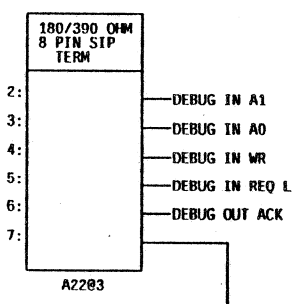
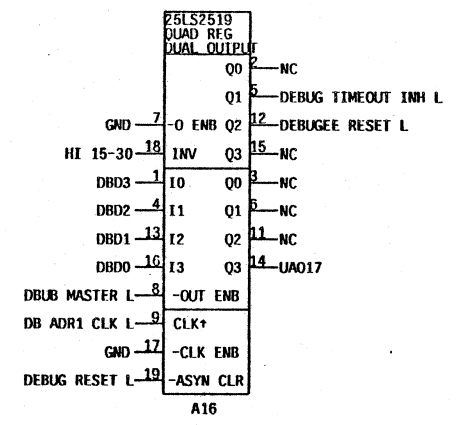
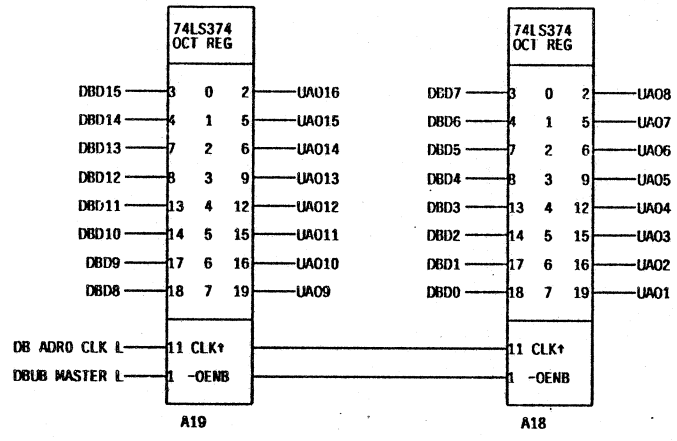

GROUND TO CONNECT  
PDP-11 TO UNIBUS

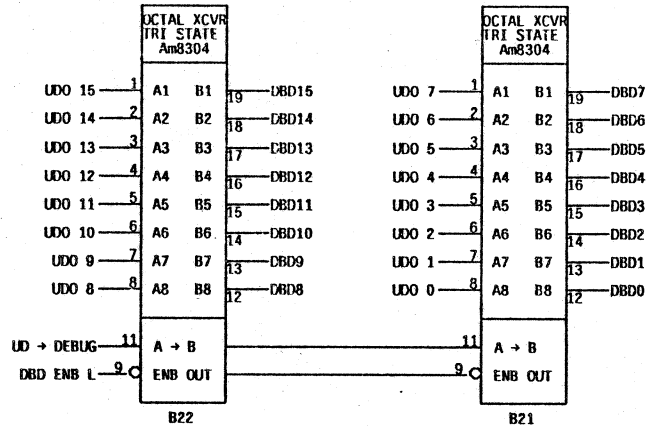
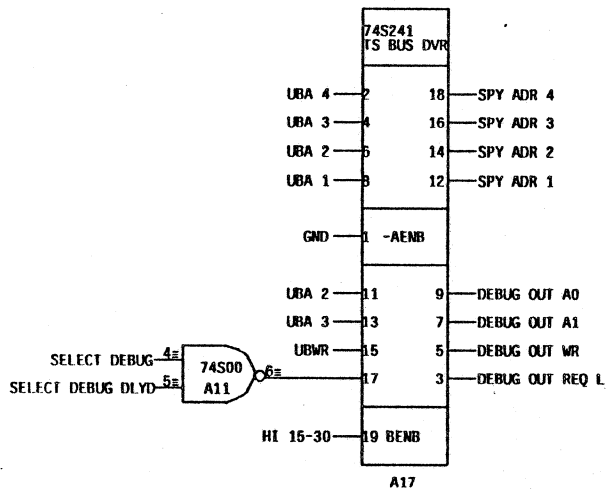
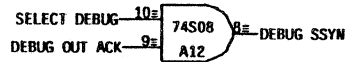
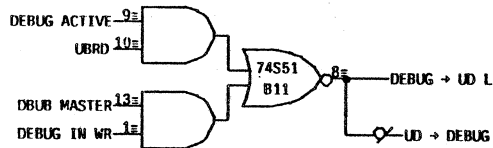
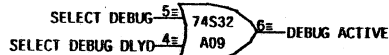
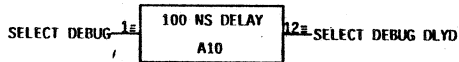
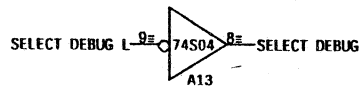

- ◁106-1▷ DBD0
- ◁106-2▷ DBD1
- ◁106-3▷ DBD2
- ◁106-4▷ DBD3
- ◁106-5▷ DBD4
- ◁106-6▷ DBD5
- ◁106-7▷ DBD6
- ◁106-8▷ DBD7
- ◁106-9▷ DBD8
- ◁106-10▷ DBD9
- ◁106-11▷ DBD10
- ◁106-12▷ DBD11
- ◁106-13▷ DBD12
- ◁106-14▷ DBD13
- ◁106-15▷ DBD14
- ◁106-16▷ DBD15
- ◁106-17▷ DEBUG OUT A0
- ◁106-18▷ DEBUG OUT A1
- ◁106-19▷ DEBUG OUT WR
- ◁106-20▷ DEBUG OUT REQ L
- ◁106-21▷ DEBUG OUT ACK
- ◁106-22▷ NC
- ◁106-23▷ NC
- ◁106-24▷ NC
- ◁106-25▷ NC

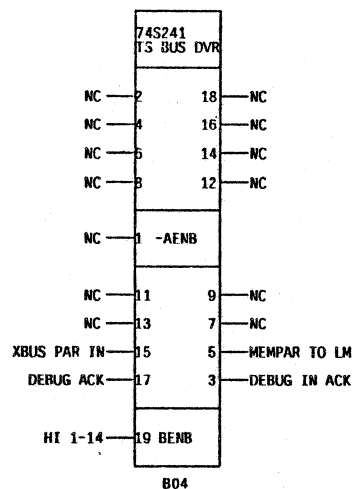

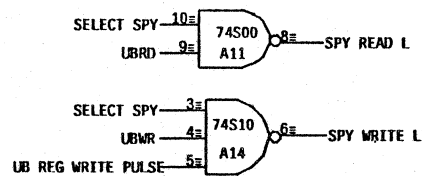
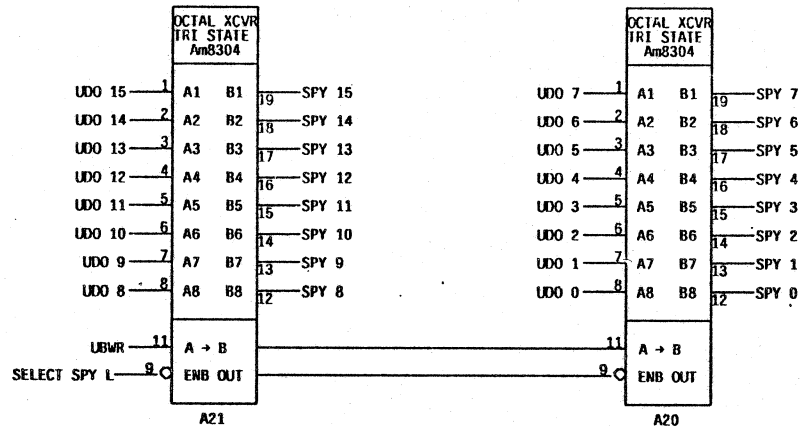

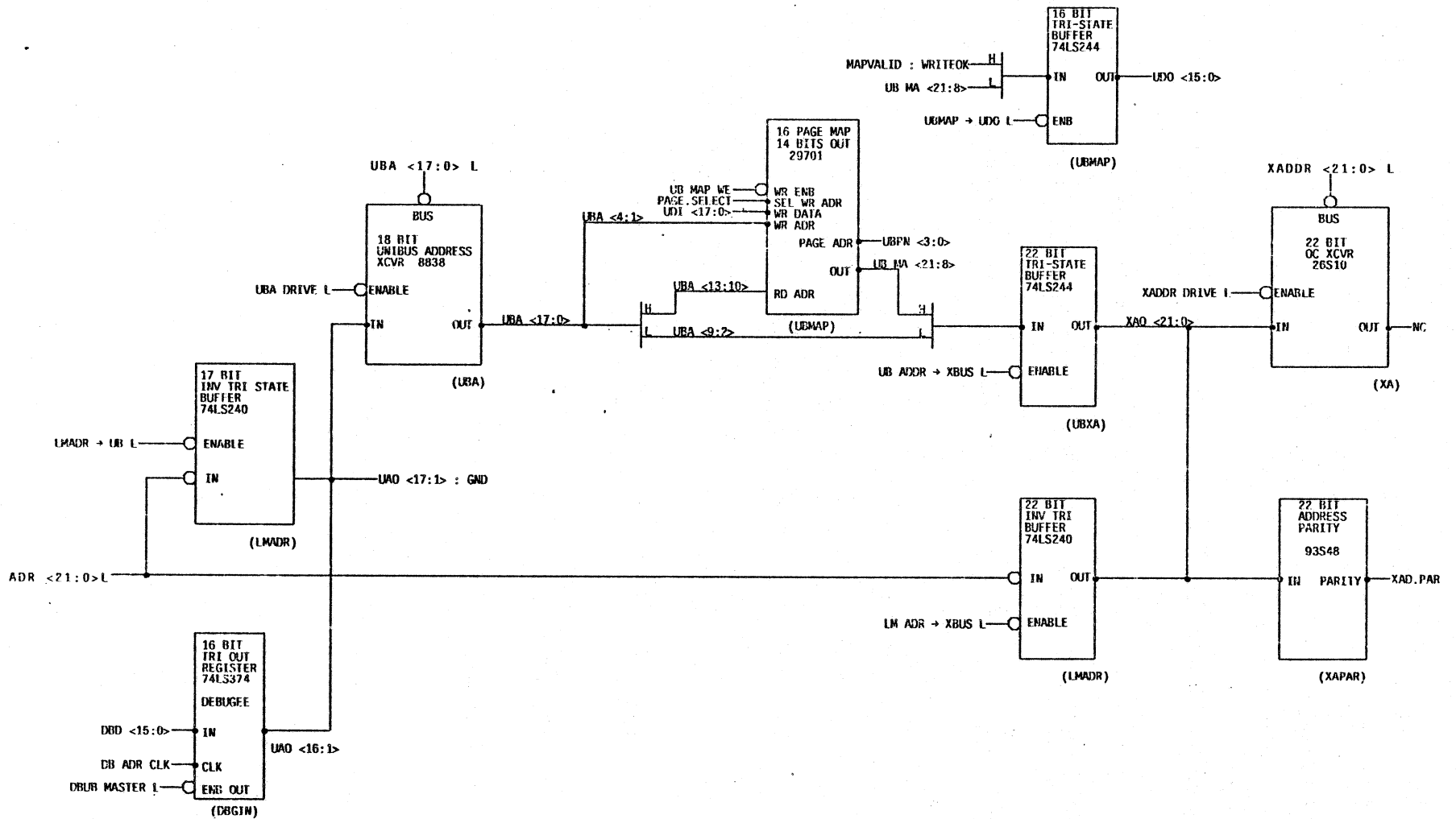







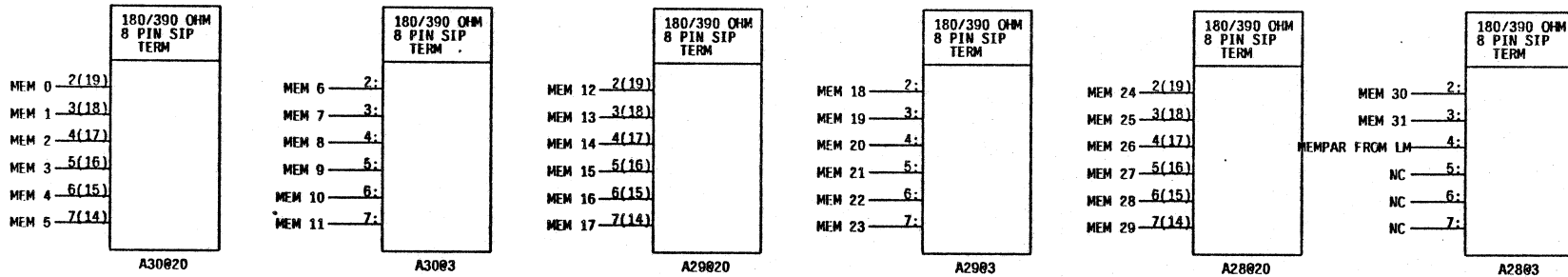
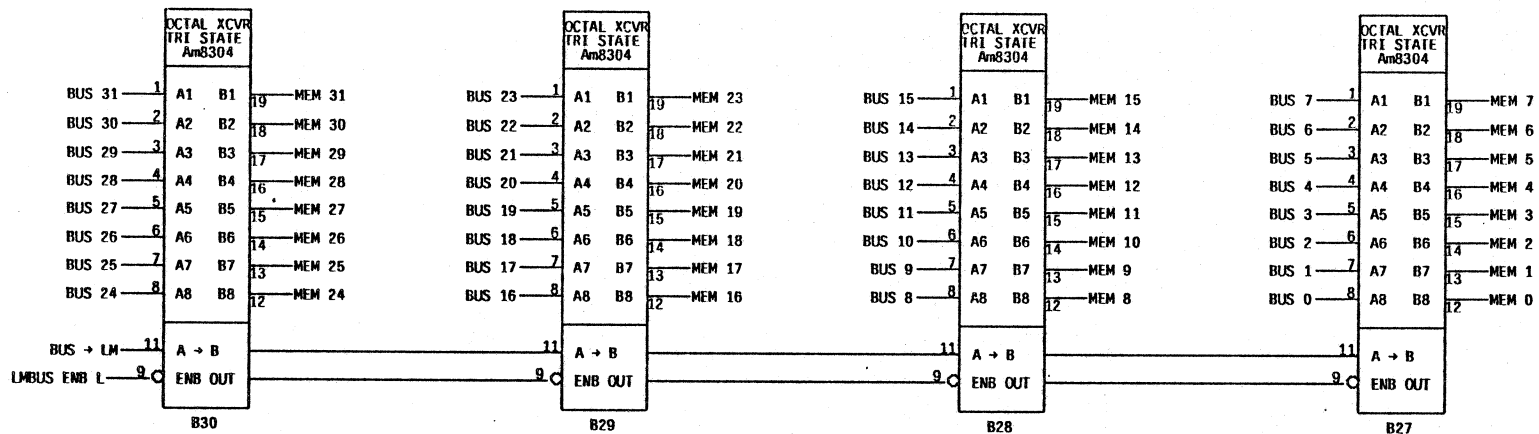

NOTE: MEMPAR TO LM is on DBGOUT

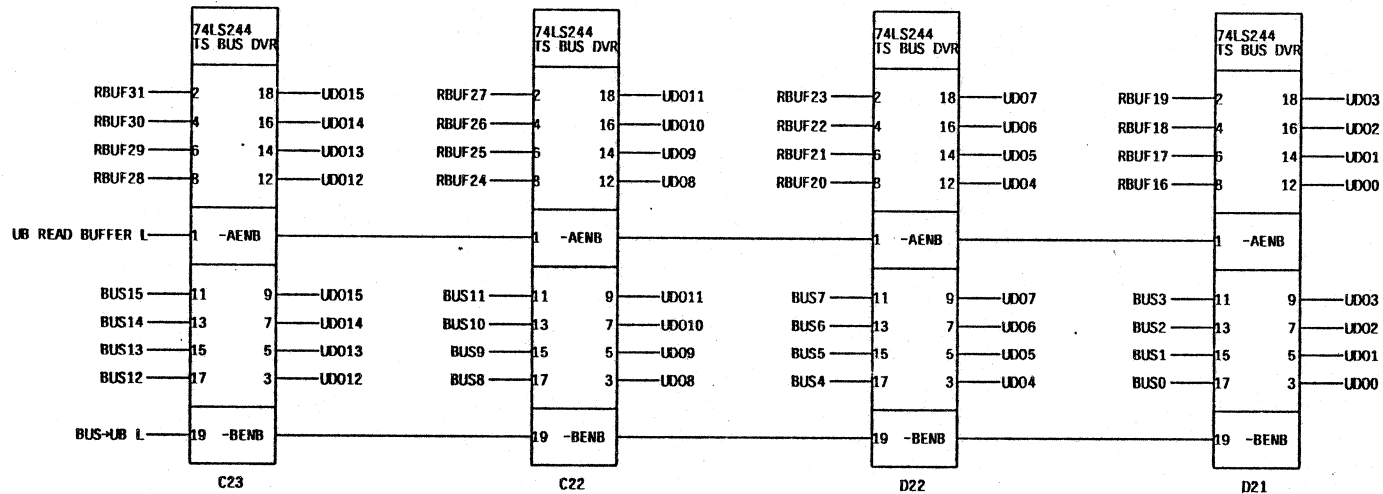
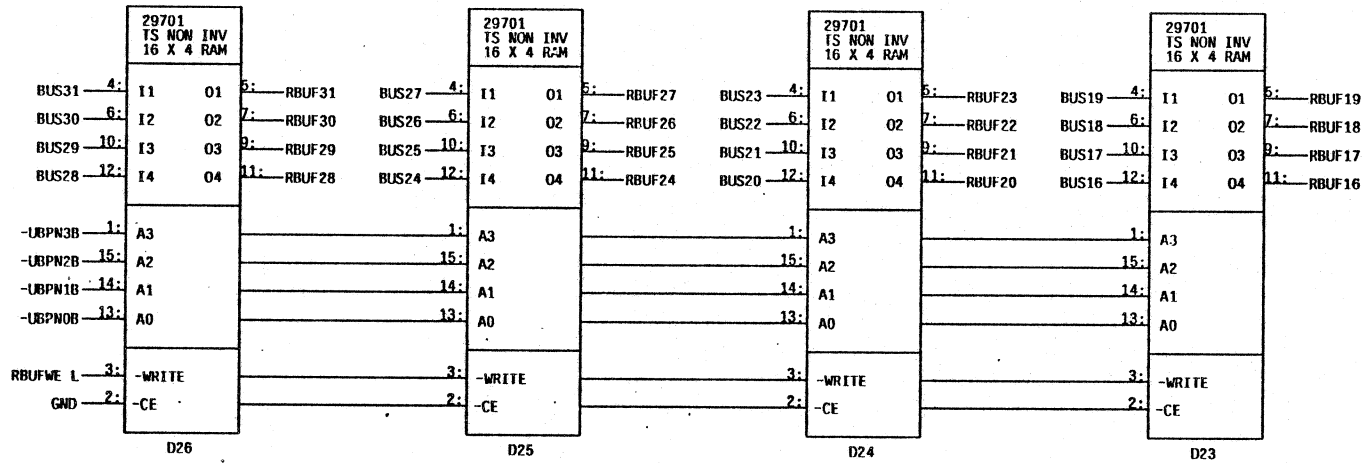

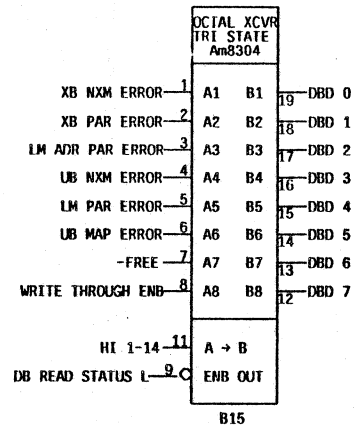
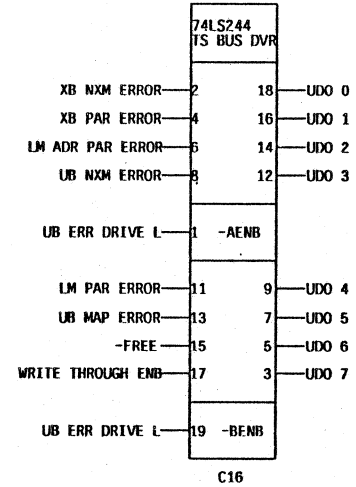
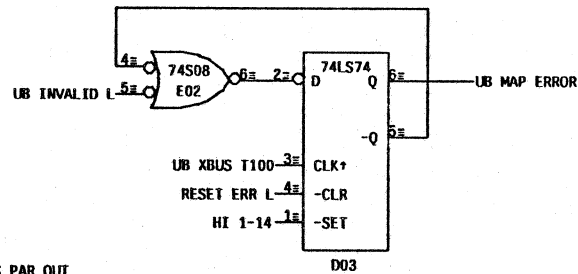
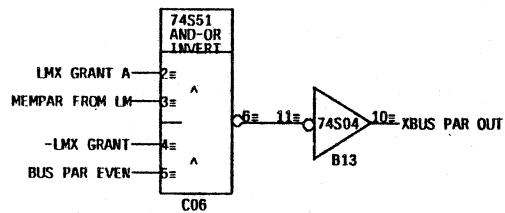
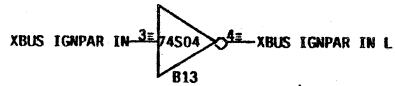
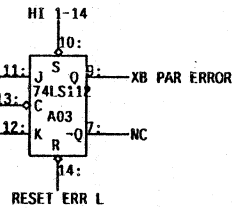
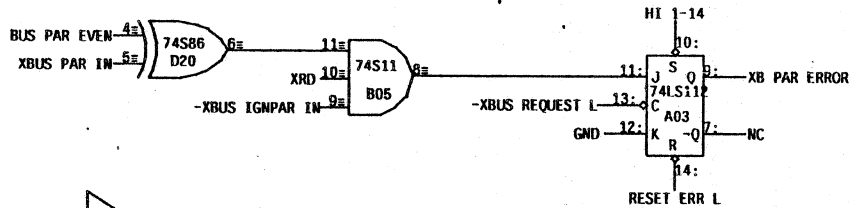
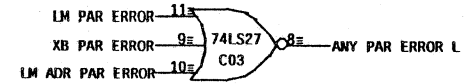
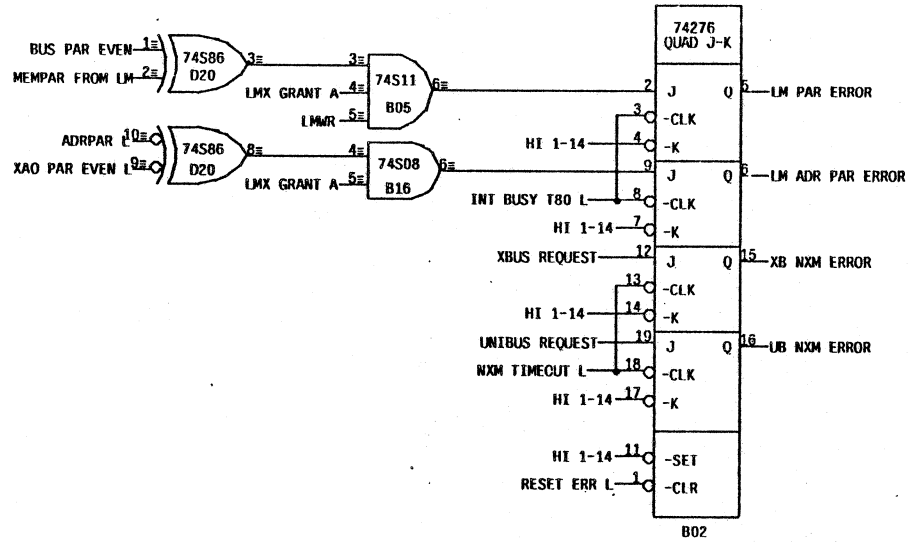

17 400 000-  
17 777 777

TOP 128K OF LM PHYSICAL ADDRESS  
IS I/O TO UNIBUS

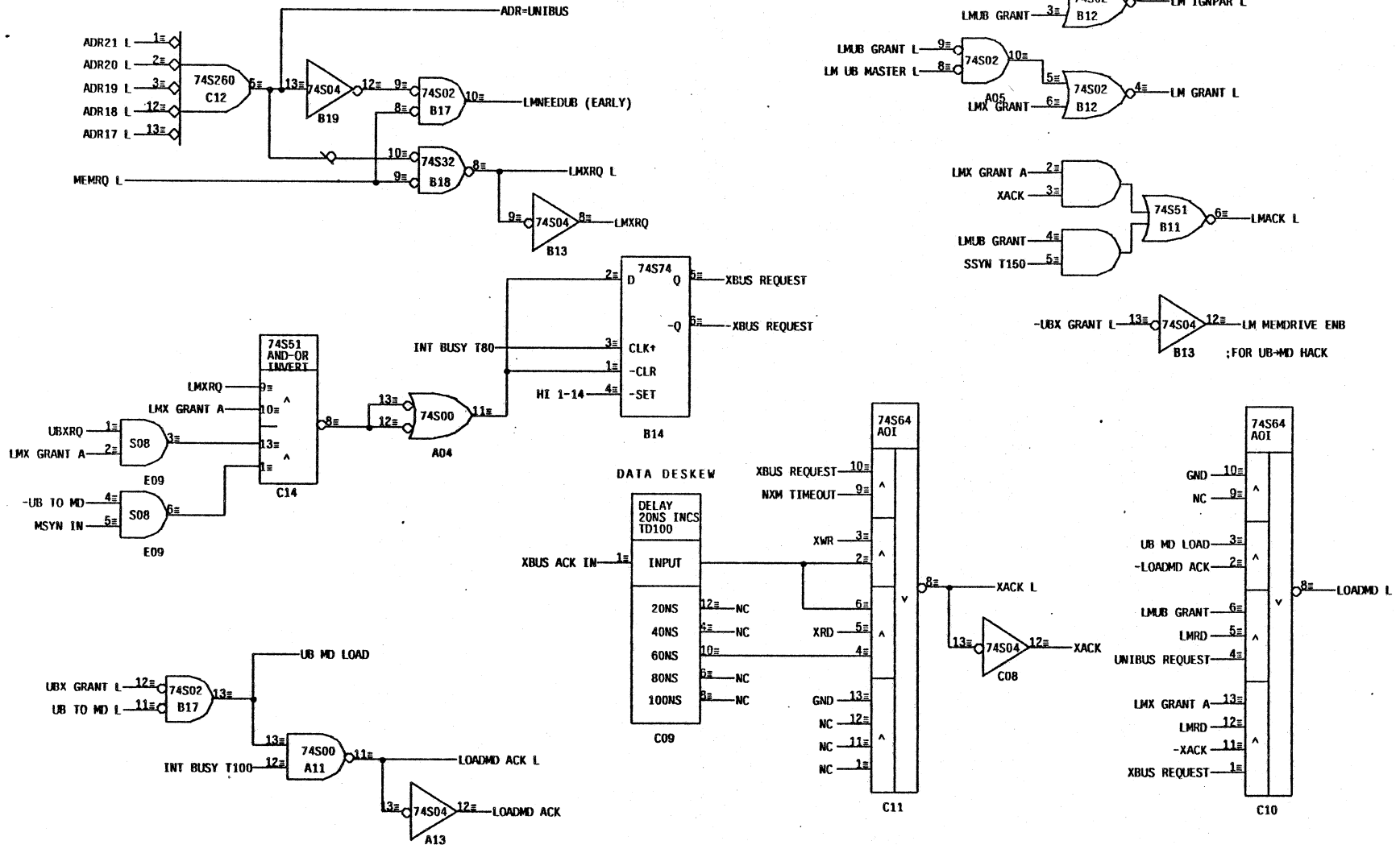

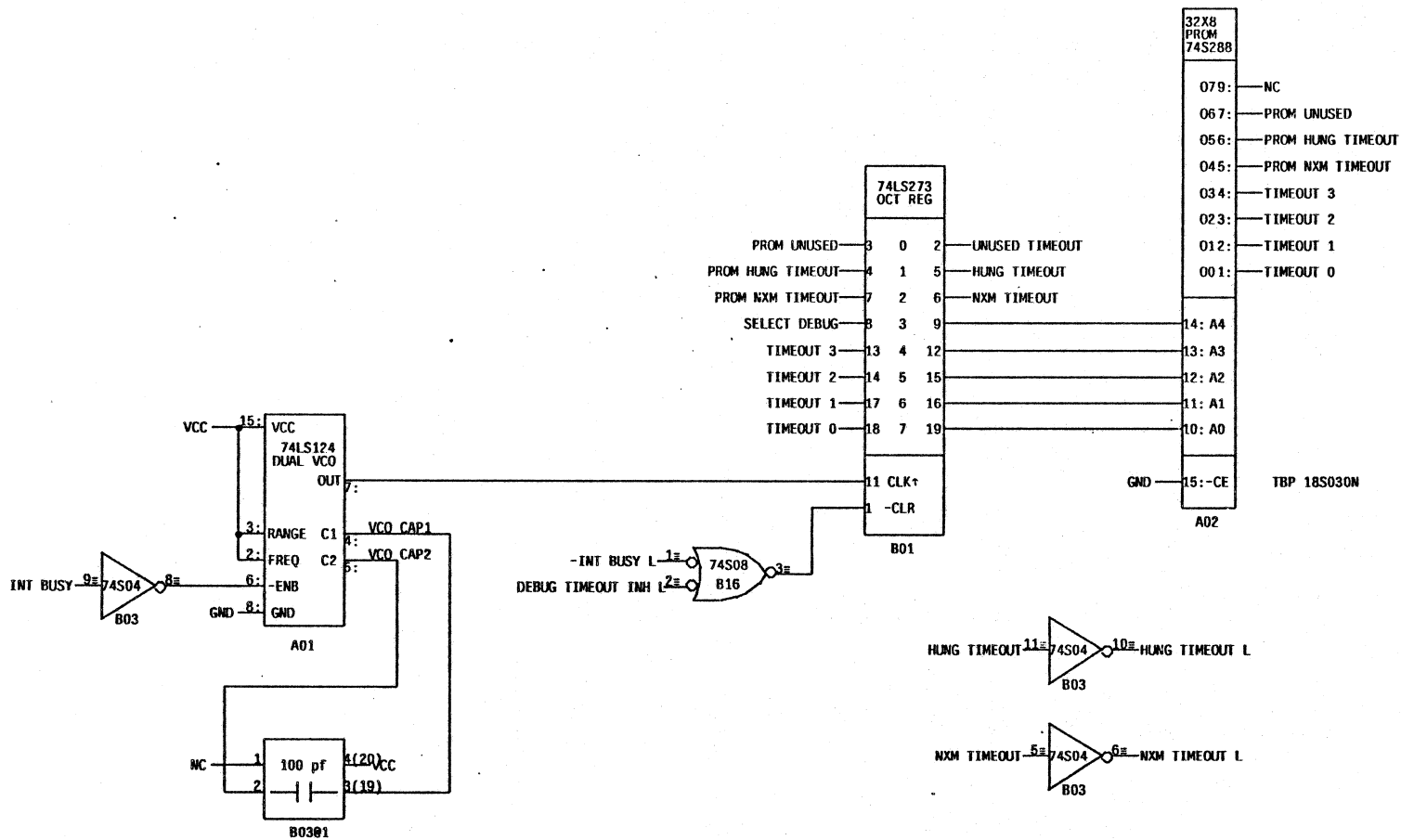

17 400 000 to  
17 777 777

THESE ARE LM ADDRESSES THAT ARE MAPPED ONTO UNIBUS  
THEY DON'T EXIST ON XBUS  
THEREFORE THEY'LL MEAN UNIBUS TO MEMORY DATA REGISTER

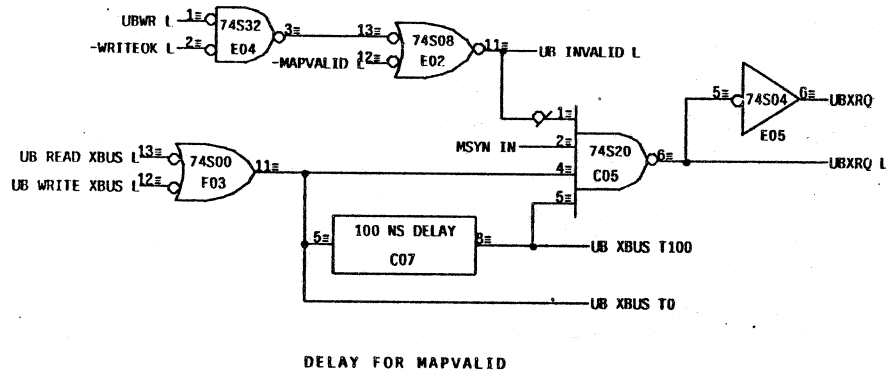

- URMA21 1:
- URMA20 2:
- URMA19 3:
- URMA18 4:
- URMA17 5:
- UBXRQ 6:
- UBWR 7: 74S133 D12 9: UB TO MD L
- MSYN IN 10:
- HI 15-30 11:
- HI 15-30 12:
- HI 15-30 13:
- HI 15-30 14:
- HI 15-30 15:

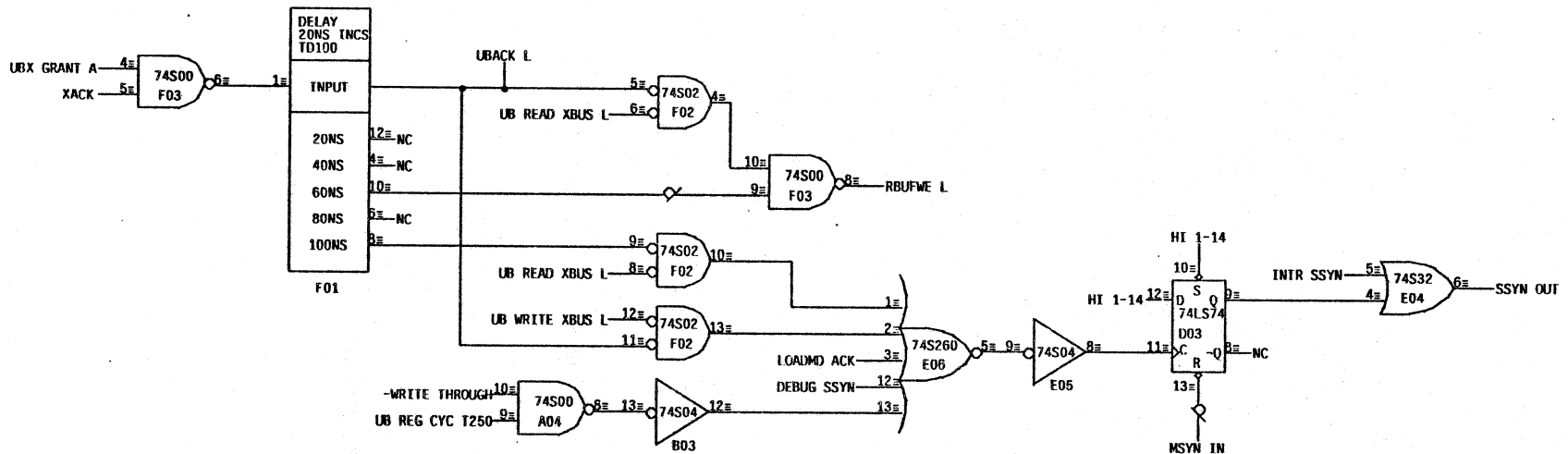

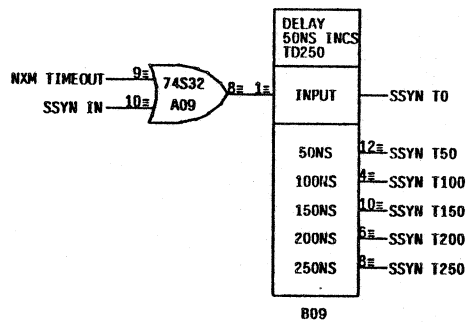
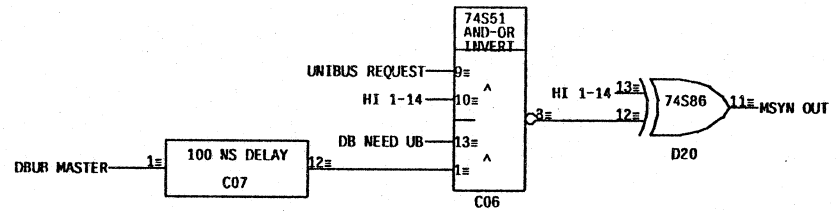
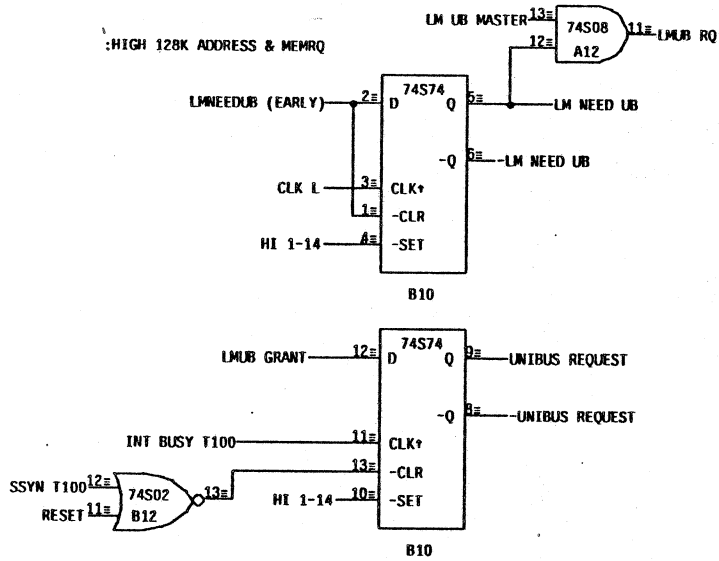





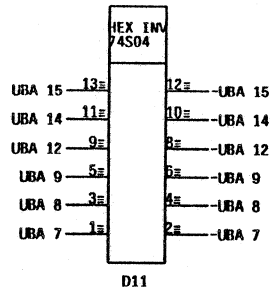
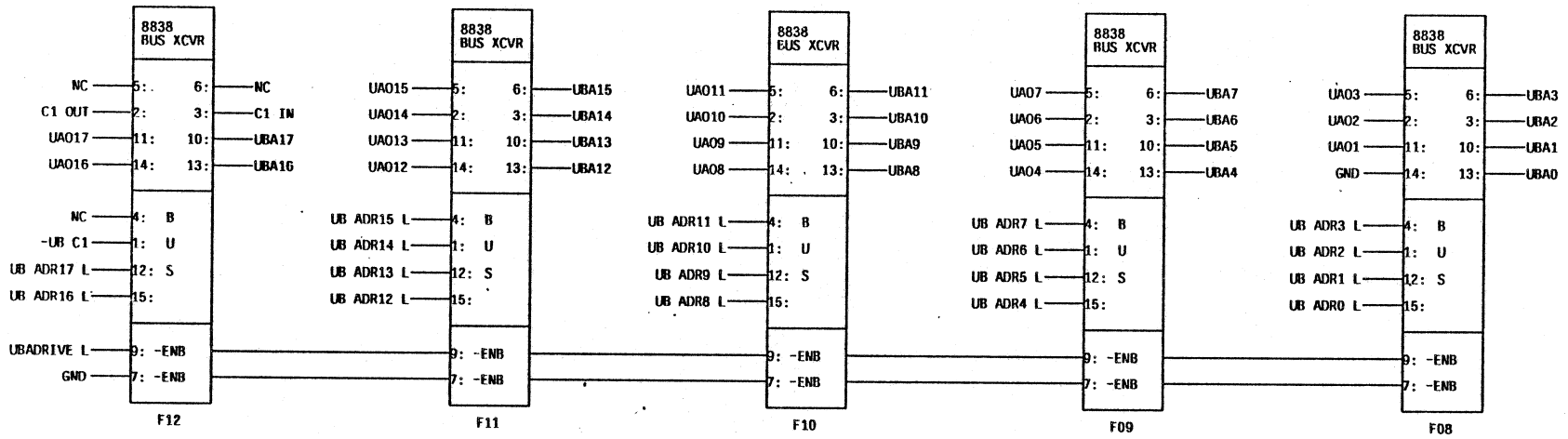

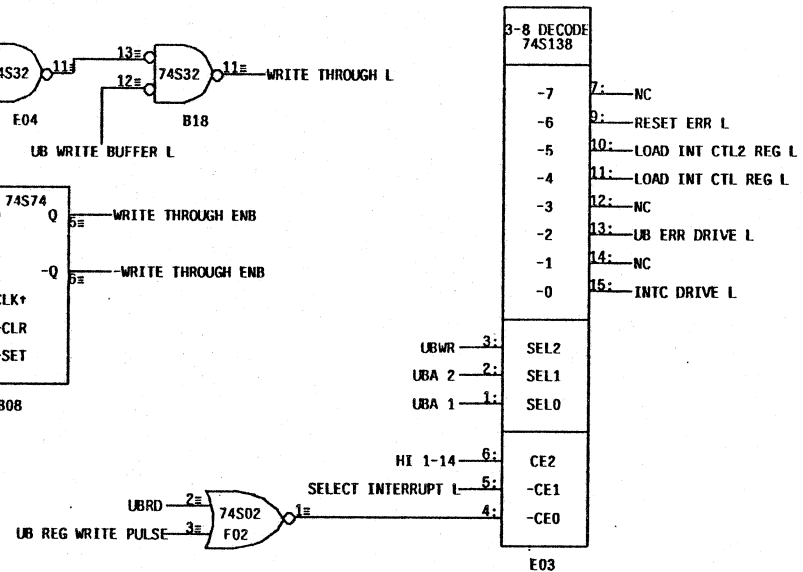
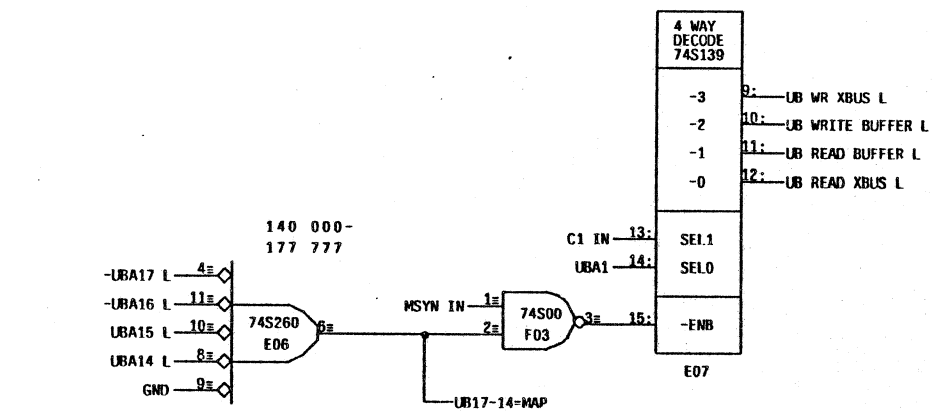
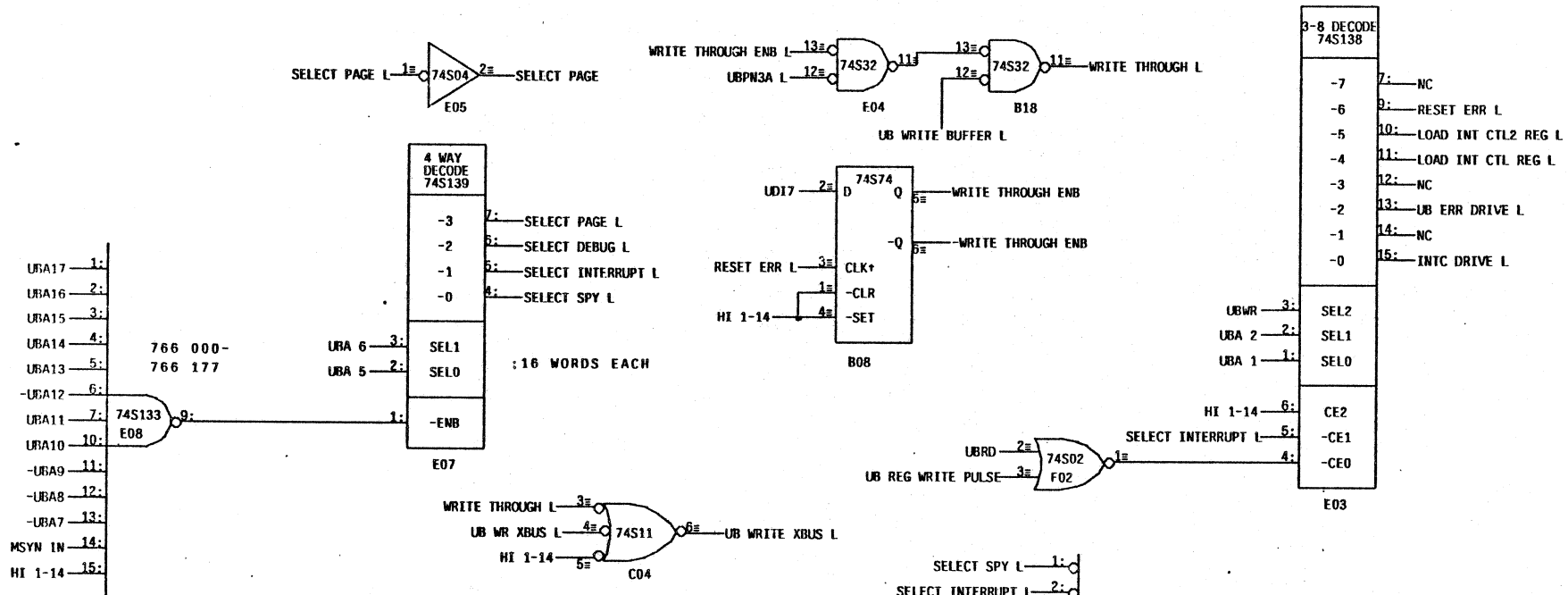

PAGES ARE 512 16-BIT WORDS LONG  
 THE FIRST 8 ARE ACCESSIBLE BY A PDP-11,  
 THE OTHER 8 ARE SHADOWED BY I/O ADDRESSES

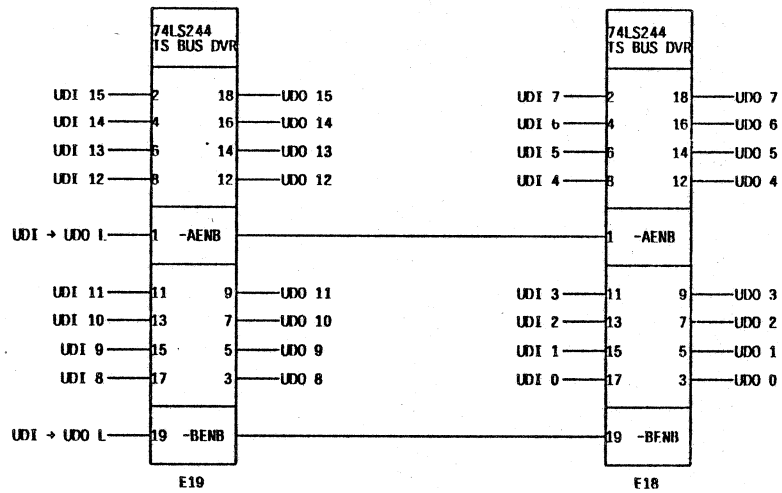
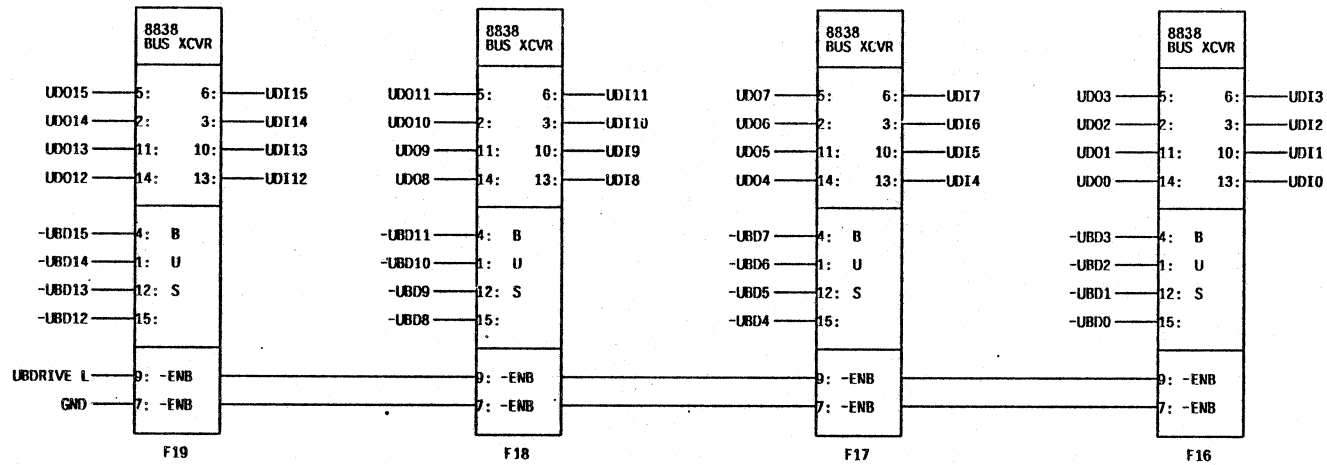

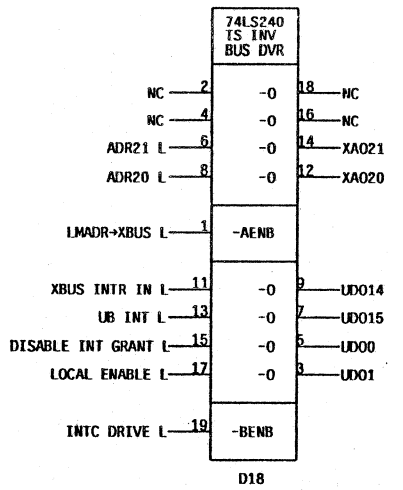
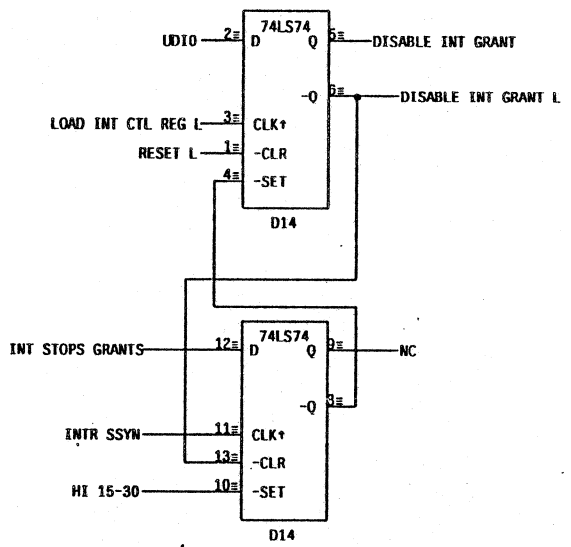
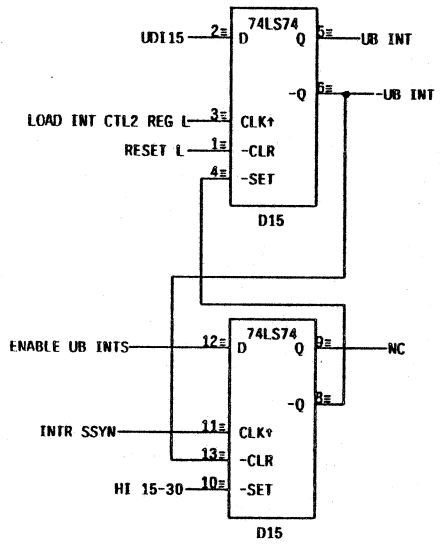

SEE CADR1: LMADR

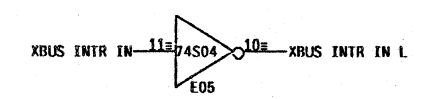
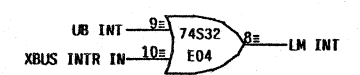
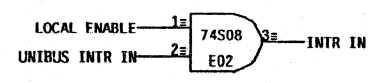
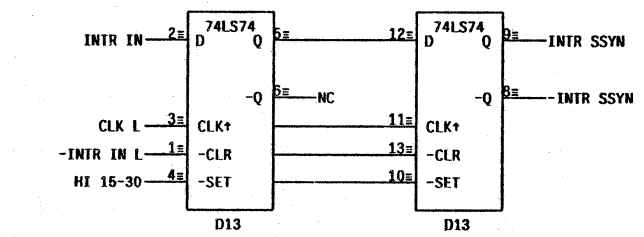
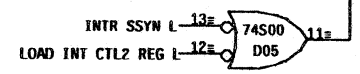
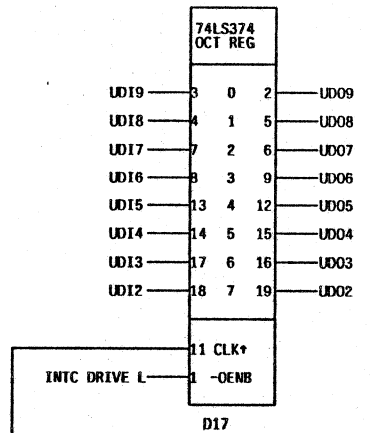
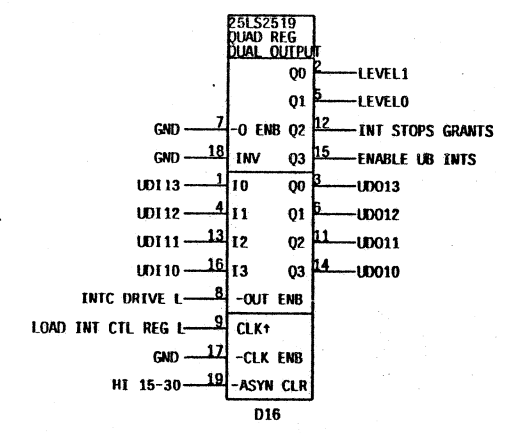

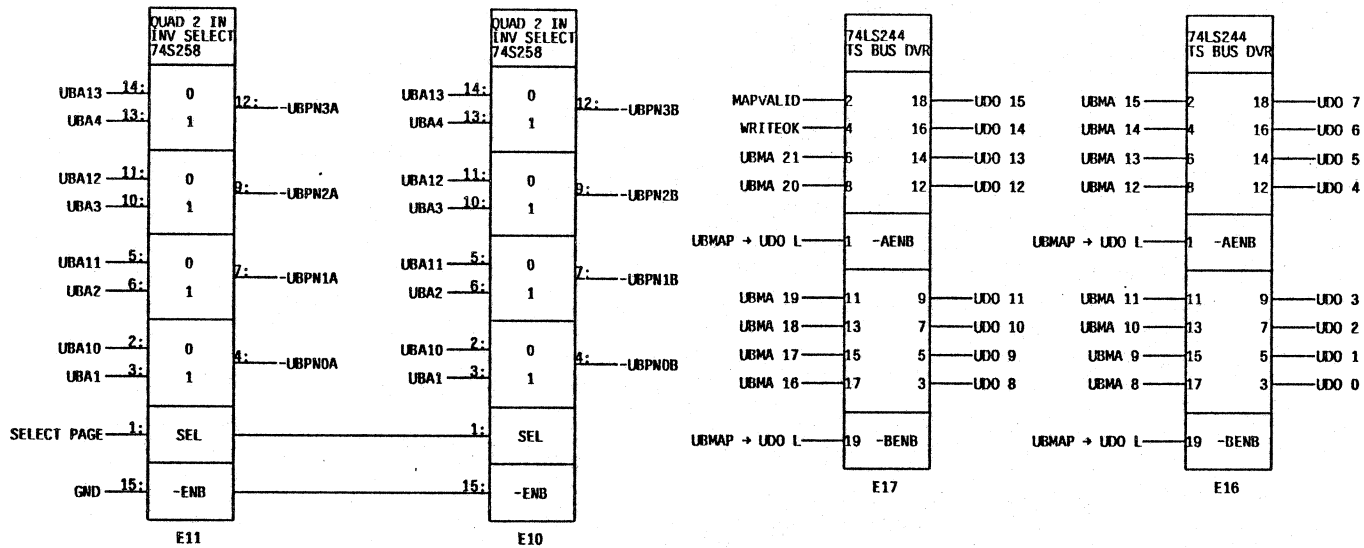
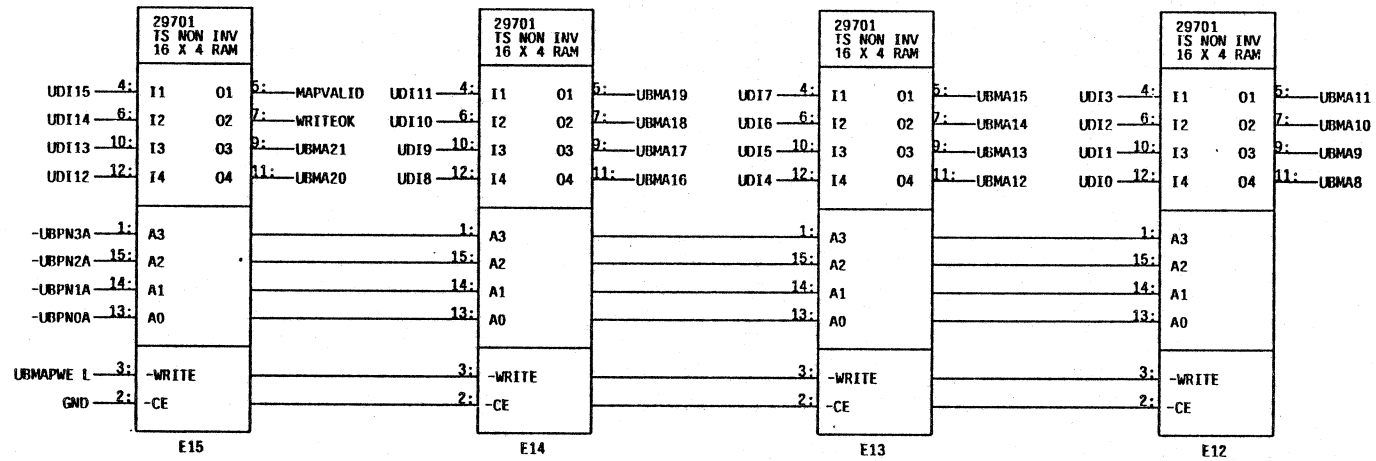

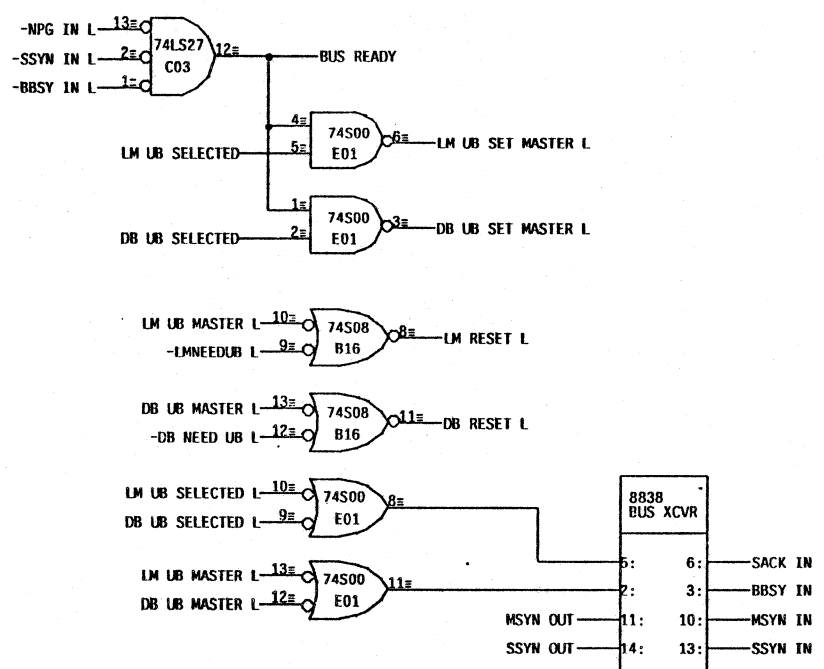
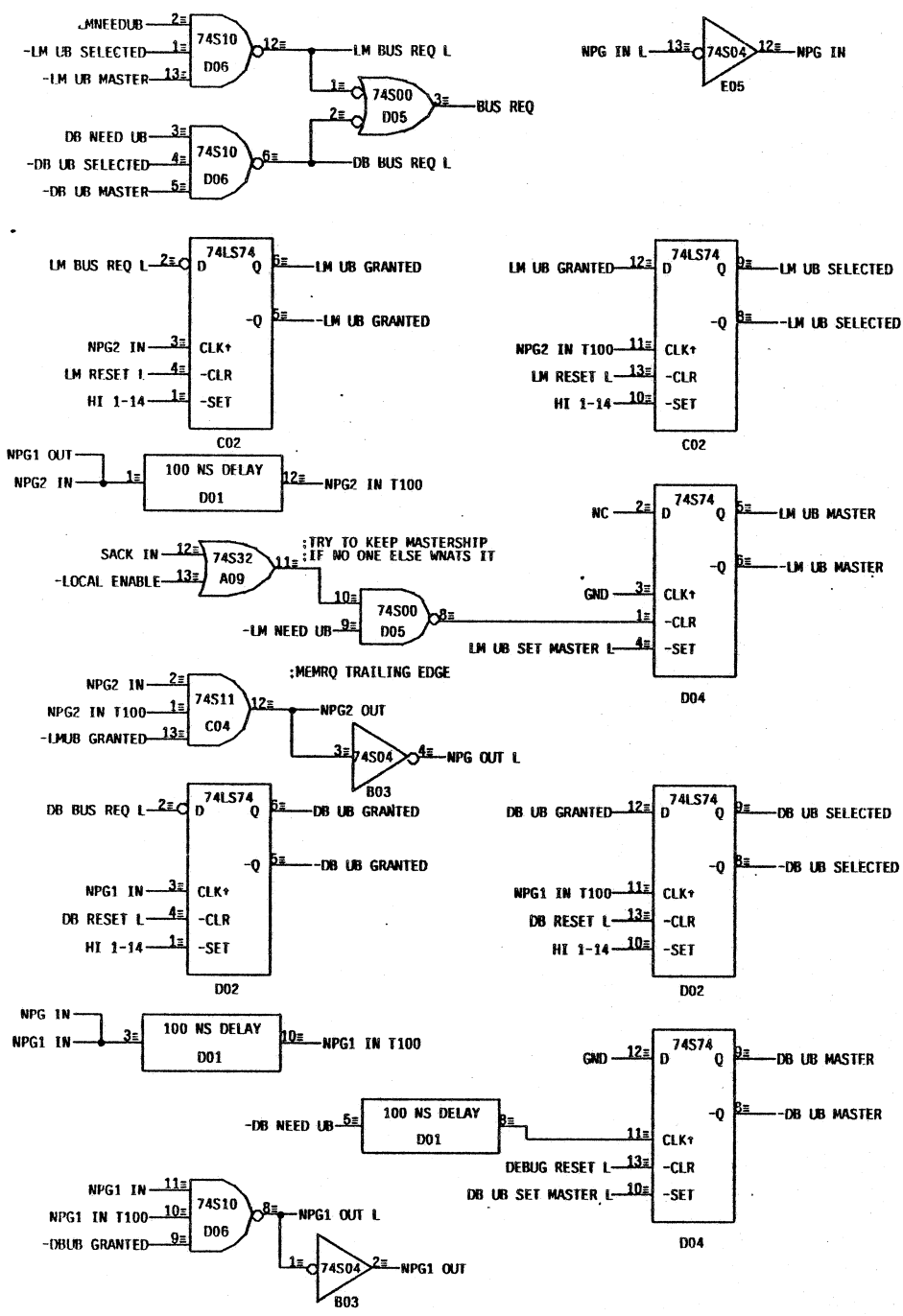

```

WITH <x:LM npg:NPG2>
WITH <x:DB npg:NPG1>
-----
x.RQ: BUS REQ, NPR:
npg.IN: set x.GRANTED;
npg.IN+100ns: [x.GRANTED: set x.SELECTED, else NPG OUT];
x.SELECTED v x.MASTER: -BUS REQ, -NPR;
x.SELECTED: SACK OUT;
assert SACK OUT: (DLY): -npg.IN
-npg.IN ^ -SSYN IN ^ -BBSY IN: BUS READY;
BUS READY ^ x.SELECTED: set x.MASTER;
x.MASTER: BBSY OUT, x.RESET;
x.RESET: clr x.GRANTED, clr x.SELECTED;
-x.RQ: clr x.MASTER;

```

NOTE: NPR is synchronized on UPRIOR and generates NPG IN if LOCAL ENABLE.

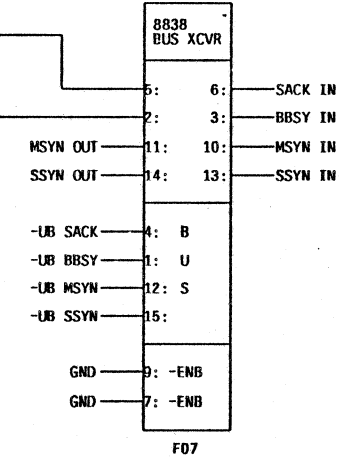

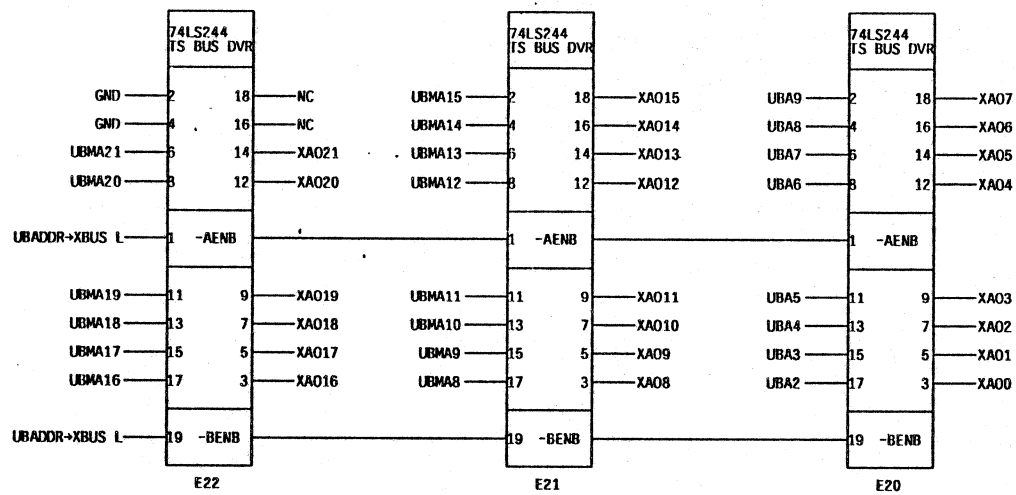



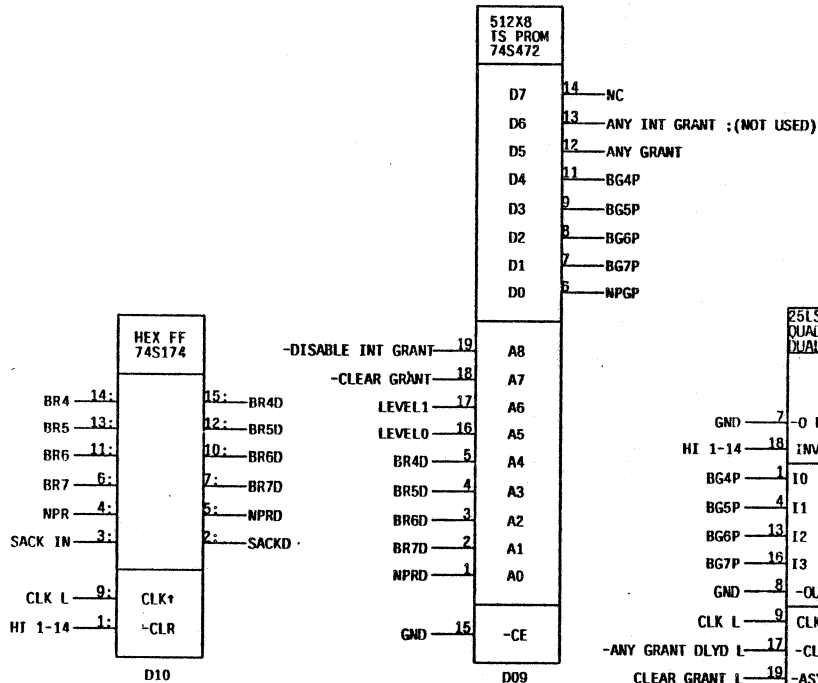

TBP 18S42N

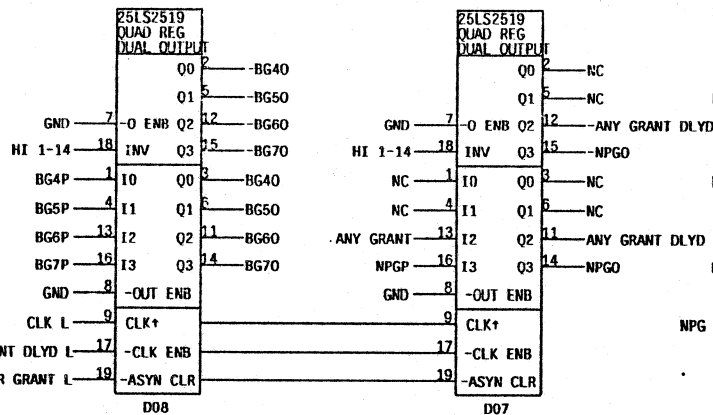

D08

D07

NOTE: GRANT TERMINATION TO 180 OHMS IS PROVIDED BY UNIBUS TERMINATOR

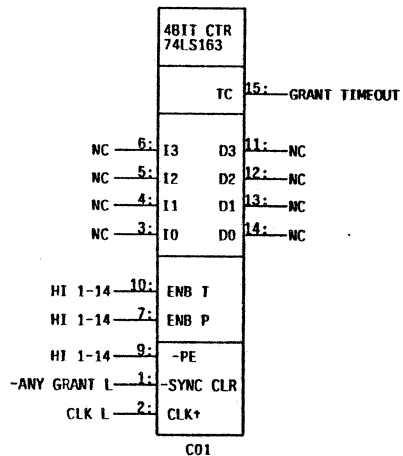
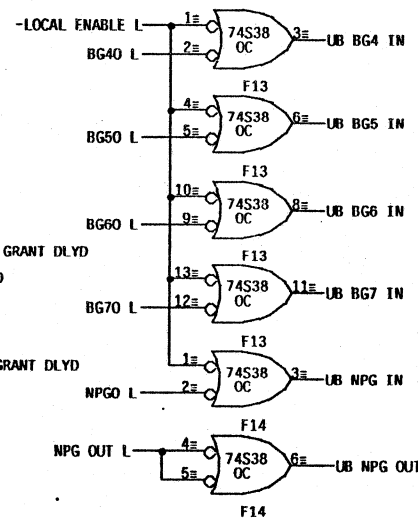

C01

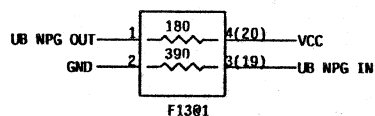
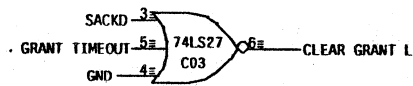

F1301

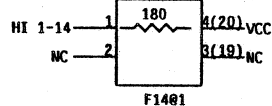

F1401

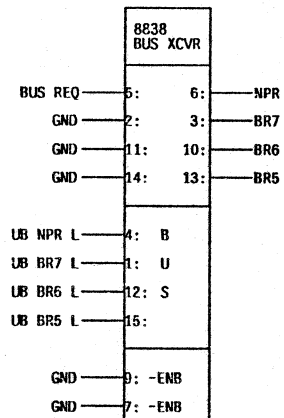

F15

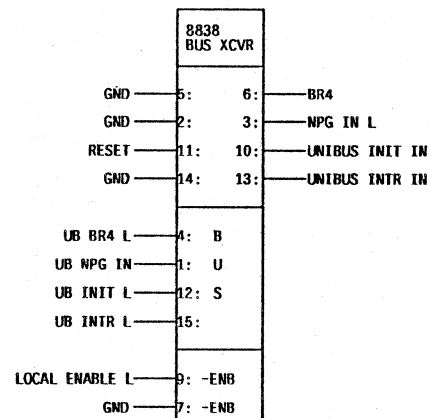

F06

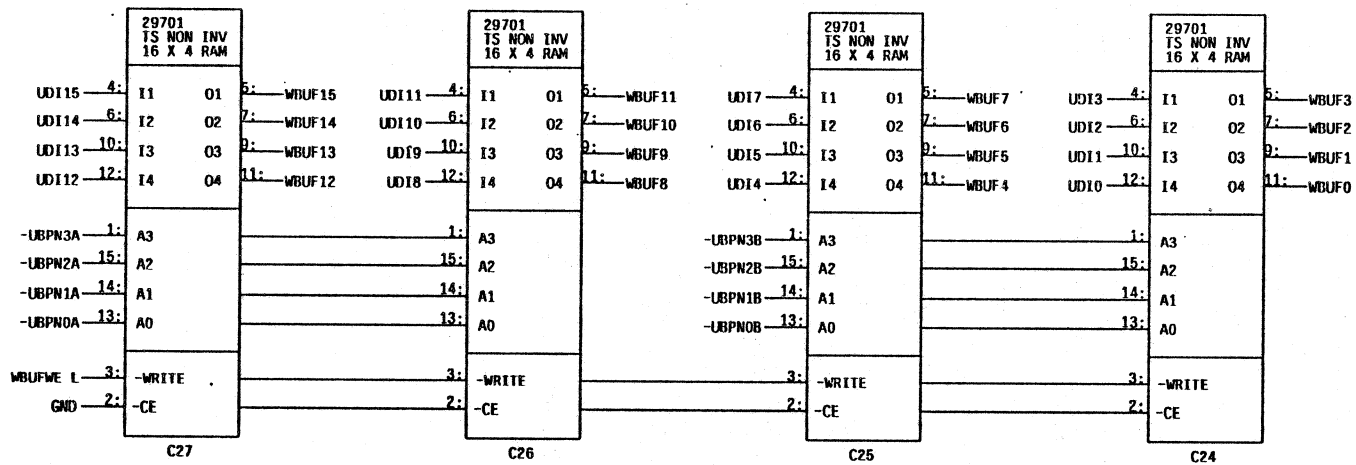

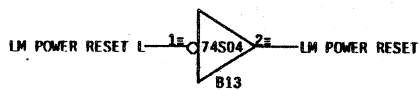
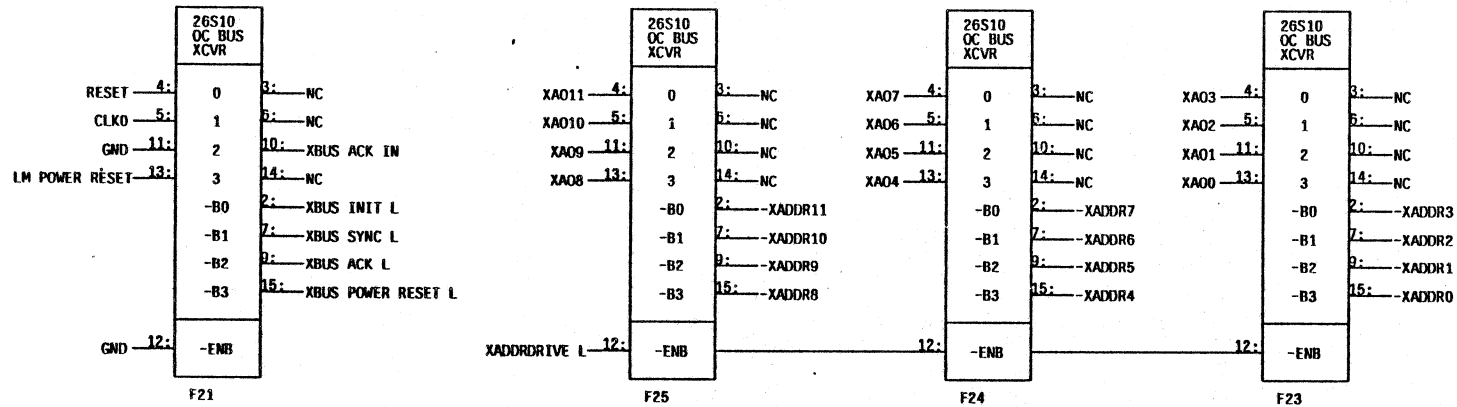
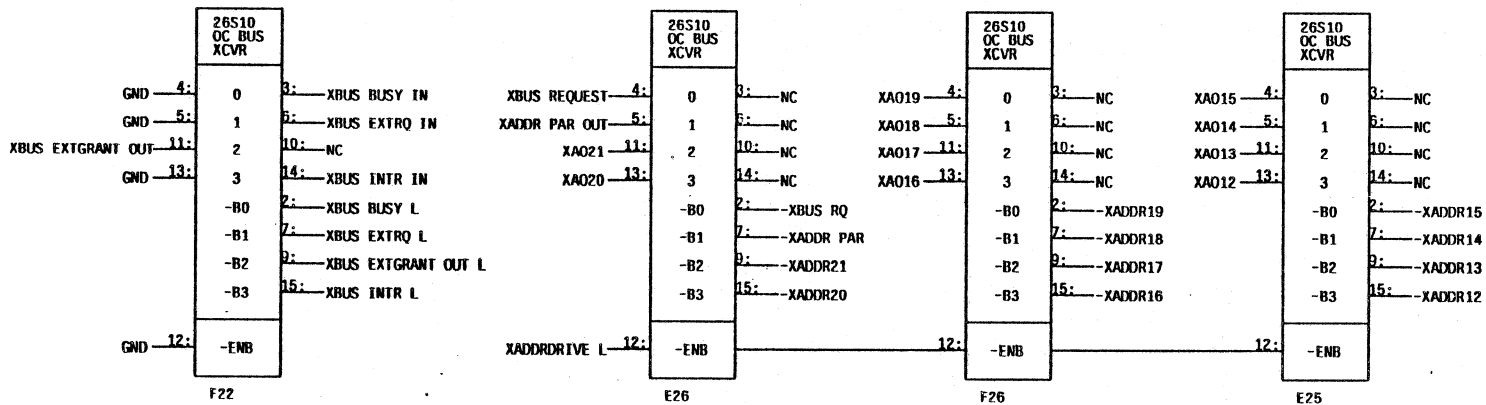

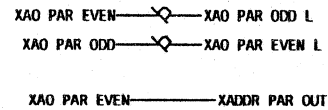
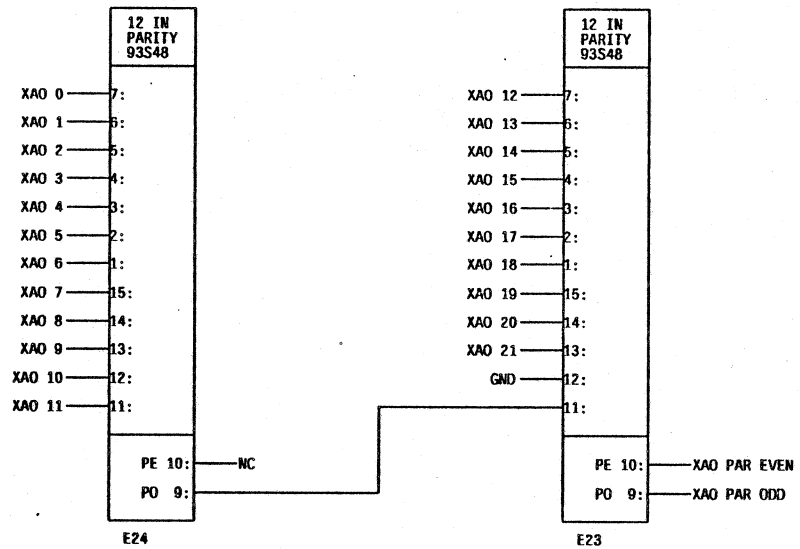

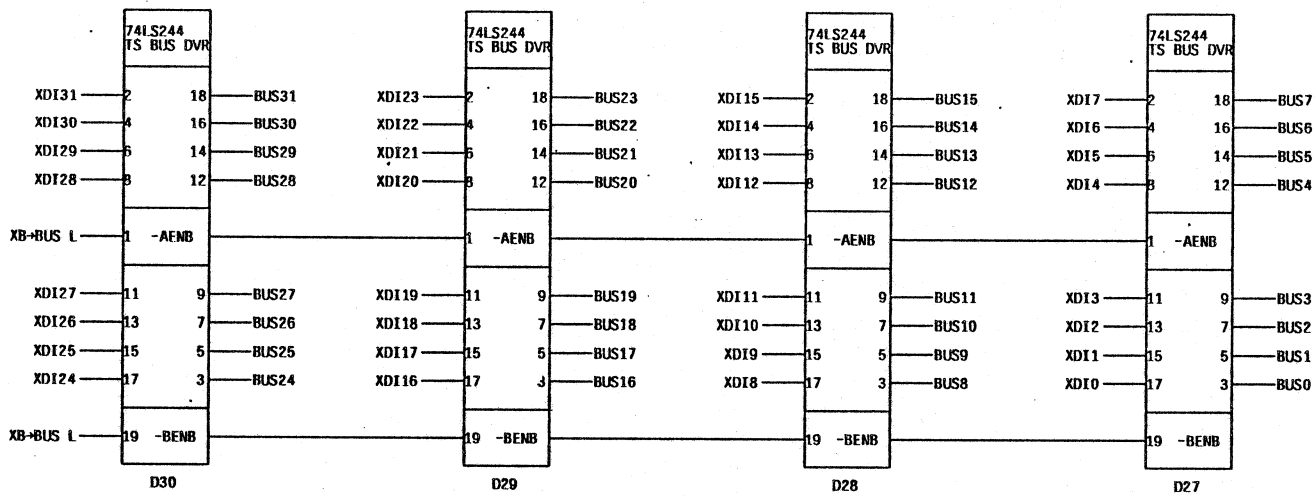

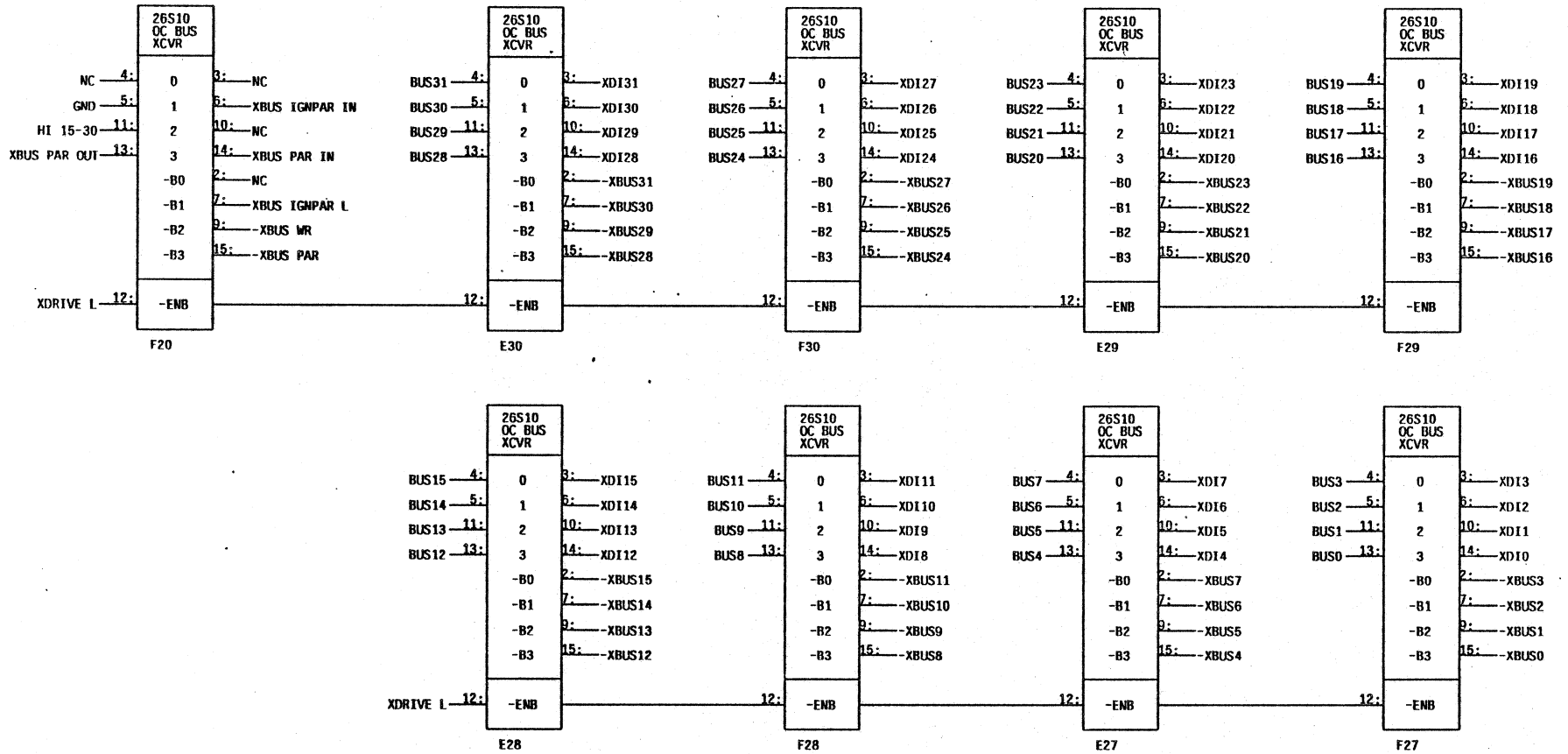

LISPM I/O BOARD

\*\*\*\*\* CADRIO:IOB UML \*\*\*\*\*  
DIP MAP \*\*\*\*\*

18-DEC-80 1049

75118 IOBKBD x	75118 IOBKBD x	74LS374 IOBKBD x	74LS374 IOBKBD x	74LS74 IOBKBD xx	74LS164 IOBKBD x
F30	E30	D30	C30	B30	A30
74LS74 IOBSE xx	74LS244 IOBSE x	74LS244 IOBCSR x	74LS374 IOBKBD x	74LS569 IOBMS2 x	74LS164 IOBKBD x
F29	E29	D29	C29	B29	A29
74LS374 CLK60H x	74LS374 CLK60H x	74LS244 CLKTOD x	74LS10 IOBKBD xxx	74LS569 IOBMS2 x	74LS164 IOBKBD x
F28	E28	D28	C28	B28	A28
74LS244 CLK60H x	74LS244 CLK60H x	74LS175 IOBCSR x	74LS74 IOBCSR xx	74LS569 IOBMS2 x	74LS14 IOBKBD OXXXXX
F27	E27	D27	C27	B27	A27
74LS374 CLKTOD x	74LS374 CLKTOD x	74LS08 IOBKBD xxxx	74LS109 IOBKBD xx	74LS569 IOBMS2 x	74LS86 IOBMS2 xxx0
F26	E26	D26	C26	B26	A26
74LS374 CLKTOD x	74LS374 CLKTOD x	74LS32 IOBCLK xxxx	74 37 IOBCLK xx00	74LS569 IOBMS2 x	74LS14 IOBMSE xxxxxx
F25	E25	D25	C25	B25	A25
74 393 CLKTOD xx	74 393 CLKTOD xx	74LS163 IOBCLK x	74LS244 IOBMS2 x	74LS569 IOBMS2 x	74LS374 IOBMSE x
F24	E24	D24	C24	B24	A24
74 393 CLKTOD xx	74 393 CLKTOD xx	74 393 CLKTOD xx	74LS74 IOBCLK xx	74LS86 IOBMS2 xxxx	74LS374 IOBMSE x
F23	E23	D23	C23	B23	A23
74LS193 CLKTIM x	74LS193 CLKTIM x	74 393 CLKTOD xx	74LS13E IOBCLK x	74LS244 CLKTOD x	74LS374 IOBMSE x
F22	E22	D22	C22	B22	A22
74LS193 CLKTIM x	74LS193 CLKTIM x	74LS74 IOBSE xx	74LS163 CLKTIM x	74LS138 CLK60H x	25LS2521 IOBMSE x
F21	E21	D21	C21	B21	A21
DM8838 IOBACV x	74LS138 IOBADR x	74LS14 CLK60H xxxx000	DUMMY20 CLK60H x	74LS174 LMUCON x	25LS2521 IOBCSR x
F20	E20	D20	C20	B20	A20

LISPM I/O BOARD

\*\*\*\*\* CADRIO;IOB UML  
DIP MAP \*\*\*\*\*

18-DEC-80 1050

DM8838 IOBXCVCV x	74S133 IOBADR x	74LS244 LMDATP x	74S133 LMUCON, x	74LS164 LMTURN x	74LS193 LMTURN x
F19	E19	D19	C19	B19	A19
DM8838 IOBXCVCV x	74LS244 LMDATP x	74LS244 LMDATP x	74LS138 LMUCON x	74LS164 LMTURN x	74LS193 LMTURN x
F18	E18	D18	C18	B18	A18
DM8838 IOBXCVCV x	74LS244 LMDATP x	74LS244 LMDATP x	74LS244 LMDATP x	MC1488L IOBSER x	74LS193 LMTURN x
F17	E17	D17	C17	B17	A17
74S38 IOBINT xxxx	 ----- 	74LS244 LMDATP x	74LS244 LMDATP x	MC1489L IOBSER xxxx	74LS161 LMTURN x
F16	E16	D16	C16	B16	A16
74S38 IOBCSR xxxx	 ----- 	74S32 LMRCTL xxxx	74S00 LMTBFC xxxx	74S74 LMMODU xx	EXAR-CL IOBSER x
F15	E15	D15	C15	B15	A15
74S175 IOBINT x	74S260 IOBINT xx	74S112 LMTURN xx	74S00 LMTBFC xxxx	74S04 LMTBFC xxxxxxx	 ----- 
F14	E14	D14	C14	B14	A14
TD100 IOBINT x	74S04 IOBADR xxxxxxx	74S112 LMTBFC xx	25LS193 LMTBUF x	74 165 LMTBUF x	 ----- 
F13	E13	D13	C13	B13	A13
74S00 IOBINT xxxx	74LS00 IOBINT xxxx	DUMMY LMMYNM x	25LS193 LMTBUF x	74 165 LMTBUF x	2651 IOBSER x
F12	E12	D12	C12	B12	A12
74LS10 IOBINT xxx	74LS02 IOBSER xxxx	P SIP100 LMMYNM x	25LS193 LMTBUF x	TD100 LMDETC x	TD25 LMDETC x
F11	E11	D11	C11	B11	A11
DM8838 IOBINT x	74S08 LMRCTL xxxx	DUMMY LMMYNM x	2147 LMTBUF x	74S08 LMTBFC xxxx	74S288 LMMODU x
F10	E10	D10	C10	B10	A10
DM8136 IOBADR x	TD250 IOBADR x	74 279 LMRCTL xxox	9401 LMTBUF x	74S04 LMDETC xxxxxxx	74S112 LMMODU xx
F09	E09	D09	C09	B09	A09



LISPM I/O BOARD

\*\*\*\*\* CADRIO:IOB UML  
DIP MAP \*\*\*\*\*

18-DEC-80 1052

DM8136 IOBADR x	74S74 IOBADR xx	74S74 LMRCTL xx	74S51 LMTBUF xx	74S02 LMTBFC xxxx	74S374 LMMODU x
F08	E08	D08	C08	B08	A08
DM8837A IOBXCVC x	74S37 IOBADR xxxx	74S00 LMRBUF xxxx	9401 LMRBUF x	74LS164 LMRBUF x	74LS164 LMRBUF x
F07	E07	D07	C07	B07	A07
DM8837A IOBXCVC x	74S251 LMYNNM x	25LS193 LMRBUF x	74S74 LMRCLK xx	74LS161 LMRCLK x	74S112 LMTCLK xx
F06	E06	D06	C06	B06	A06
74S251 LMYNNM x	74S51 LMRBUF xx	25LS193 LMRBUF x	74S37 LMRBUF xxxx	74LS161 LMRCLK x	EXAR-CL LMTCLK x
F05	E05	D05	C05	B05	A05
74LS161 LMYNNM x	74S00 LMUCON xxxx	25LS193 LMRBUF x	2147 LMRBUF x	TD100 LMDETC x	26S02 LMRCTL xx
F04	E04	D04	C04	B04	A04
74LS161 LMYNNM x	74S00 LMRCTL xxxx	74S04 LMTCLK xxxxxx	TD250 LMRCLK x	74S163 LMTCLK x	DUMMY LMLNDR x
F03	E03	D03	C03	B03	A03
74LS161 LMYNNM x	74S158 LMLNDR x	74S10 LMMODU xxx	74S08 LMRBUF xxxx	74S74 LMDETC xx	26LS31 LMLNDR xxxx
F02	E02	D02	C02	B02	A02
74S11 LMMODU 0x0	74S174 LMYNNM x	74S287 LMYNNM x	74S74 LMDETC xx	74S04 LMRCLK xxxxxx	26LS33 LMLNDR xxxx
F01	E01	D01	C01	B01	A01



LISPM I/O BOARD

CADRIO:IOB UML

18-DEC-80 1053

\*\*\*\*\* EDGE CONNECTIONS Flags: (# Output, @ Terminator, ---- Dedicated ground, ++++ Dedicated power) \*\*\*\*\*

-E-		-F-		-J01-		-J02-	
A1 GND	# A1	A2 +5.0V+++++	# A2	01 GND	# 01	02 INTERFERE+	# 02
B1	# B1	B2 -5.0V	# B2	03 INTERFERE-	# 03	04 GND	# 04
C1 -A12*	# C1	C2 GND-----	# C2	05 RCVR.DATA+	# 05	06 RCVR.DATA-	# 06
D1 -A17*	# D1	D2 -A15*	# D2	07 GND	# 07	08 TRANS.DATA+	# 08
E1 -MSYN*	# E1	E2 -A16*	# E2	09 TRANS.DATA-	# 09	10 GND	# 10
F1 -A2*	# F1	F2 -C1*	# F2	11 NC	# 11	12	# 12
H1 -A1*	# H1	H2 -A0*	# H2	13	# 13	14	# 14
J1 -SSYN*	# J1	J2 -C0*	# J2	15 -NPR*	# 15	16	# 16
K1 -A14*	# K1	K2 -A13*	# K2	17	# 17	18	# 18
L1 -A11*	# L1	L2	# L2	19	# 19	20	# 20
M1	# M1	M2 GND	# M2	21 -INTR*	# 21	22	# 22
N1 GND	# N1	N2 -A8*	# N2	23 NC	# 23	24	# 24
P1 -A10*	# P1	P2 -A7*	# P2	25	# 25	26 GND-----	# 26
R1 -A9*	# R1	R2	# R2	27 GND-----	# 27	28 GND-----	# 28
S1	# S1	S2 GND	# S2	29 GND-----	# 29	30 GND-----	# 30
T1 GND-----	# T1	T2 -SACK*	# T2	31 GND-----	# 31	32 GND-----	# 32
U1 -A6*	# U1	U2 -A4*	# U2	33 GND-----	# 33	34 GND-----	# 34
V1 -A5*	# V1	V2 -A3*	# V2	35 GND-----	# 35	36 POWER LINE ~+	# 36
				37 -----	# 37	38 -----	# 38
				39 -----	# 39	40 -----	# 40
				41 -----	# 41	42 -----	# 42
				43 -----	# 43	44 -----	# 44
				45 -----	# 45	46 -----	# 46
				47 -----	# 47	48 -----	# 48
				49 -----	# 49	50 -----	# 50

LISPM I/O BOARD

CADRIO:IOB UML

18-DEC-80 1053

\*\*\*\*\* EDGE CONNECTIONS Flags: (# Output, @ Terminator, ---- Dedicated ground, ++++ Dedicated power) \*\*\*\*\*

-J03-		-J04-		-J05-		-J06-	
01 H SYNC	01	01 GPI0	01	01 GPI0	01	01	01
02 V SYNC	02	02 GPI1	02	02 GPI1	02	02	02
03 FH1	03	03 GPI2	03	03 GPI2	03	03	03
04	04	04 GPI3	04	04 GPI3	04	04	04
05	05	05 GPI4	05	05 GPI4	05	05	05
06	06	06 GPI5	06	06 GPI5	06	06	06
07	07	07 GPI6	07	07 GPI6	07	07	07
08	08	08 GPI7	08	08 GPI7	08	08	08
09	09	09 GPI8	09	09 GPI8	09	09	09
10 AUDIO+ *	10	10 GPI9	10	10 GPI9	10	10	10
11 KBDCLK+ *	11	11 GPO0	11	11 GPO0	# 11	# 11	# 11
12 KBDIN+ *	12	12 GPO1	12	12 GPO1	# 12	# 12	# 12
13 *VERB	13	13 GPO2	13	13 GPO2	# 13	# 13	# 13
14 *VERA	14	14 GPO3	14	14 GPO3	# 14	# 14	# 14
15 *HORB	15	15 GPO4	15	15 GPO4	# 15	# 15	# 15
16 *HORA	16	16 GPO5	16	16 GPO5	# 16	# 16	# 16
17 *HEADSW	17	17 GPO6	17	17 GPO6	# 17	# 17	# 17
18 *MIDSW	18	18 GPO7	18	18 GPO7	# 18	# 18	# 18
19 *TAILSW	19	19 GPO8	19	19 GPO8	# 19	# 19	# 19
20	20	20 GPO9	20	20 GPO9	# 20	# 20	# 20
21 -----	21 -----	21 -----	21	21 -----	21	21	21
22 -----	22 -----	22 -----	22	22 -----	22	22	22
23 FH2-----	23 -----	23 -----	23	23 -----	23	23	23
24 -----	24 -----	24 -----	24	24 -----	24	24	24
25 -----	25 -----	25 -----	25	25 -----	25	25	25
26 -----	26 -----	26 -----	26	26 -----	26	26	26
27 -----	27 -----	27 -----	27	27 -----	27	27	27
28 -----	28 -----	28 -----	28	28 -----	28	28	28
29 -----	29 -----	29 -----	29	29 -----	29	29	29
30 AUDIO- *-----	30 -----	30 -----	30	30 -----	30	30	30
31 KBDCLK- *-----	31 -----	31 -----	31	31 -----	31	31	31
32 KBDIN- *-----	32 -----	32 -----	32	32 -----	32	32	32
33 GND-----	# 33 -----	33 -----	33	33 -----	33	33	33
34 GND-----	# 34 -----	34 -----	34	34 -----	34	34	34
35 GND-----	# 35 -----	35 -----	35	35 -----	35	35	35
36 GND-----	# 36 -----	36 -----	36	36 -----	36	36	36
37 GND-----	# 37 -----	37 -----	37	37 -----	37	37	37
38 GND-----	# 38 -----	38 -----	38	38 -----	38	38	38
39 GND-----	# 39 -----	39 -----	39	39 -----	39	39	39
40 -----	40 -----	40 -----	40	40 -----	40	40	40
		41 -----	41	41 -----	41	41	41
		42 -----	42	42 -----	42	42	42
		43 -----	43	43 -----	43	43	43
		44 -----	44	44 -----	44	44	44
		45 -----	45	45 -----	45	45	45
		46 -----	46	46 -----	46	46	46
		47 -----	47	47 -----	47	47	47
		48 -----	48	48 -----	48	48	48
		49 -----	49	49 -----	49	49	49
		50 -----	50	50 -----	50	50	50

LISPM I/O BOARD CADRIO:IOB UML 18-DEC-80 1054  
 \*\*\*\*\* EDGE CONNECTIONS Flags: (# Output, @ Terminator, ---- Dedicated ground, ++++ Dedicated power) \*\*\*\*\*  
 -J07- -J08- -J09- -J10-

01 GPI0	01 GPO0	# 01 EIA DATA OUT	# 01
02 GPI1	02 GPO1	# 02 EIA DATA IN	02
03 GPI2	03 GPO2	# 03 EIA RTS OUT	# 03
04 GPI3	04 GPO3	# 04 EIA CTS IN	04
05 GPI4	05 GPO4	# 05 EIA DSR IN	05
06 GPI5	06 GPO5	# 06 EIA DCD IN	06
07 GPI6	07 GPO6	# 07 EIA DTR OUT	# 07
08 GPI7	08 GPO7	# 08	08
09 GPI8	09 GPO8	# 09	09
10 GPI9	10 GPO9	# 10	10
11 GPI10	11 GPO10	# 11	11
12 GPI11	12 GPO11	# 12	12
13 GPI12	13 GPO12	# 13	13
14 GPI13	14 GPO13	# 14	14
15 GPI14	15 GPO14	# 15	15
16 GPI15	16 GPO15	# 16	16
17 GPO0	# 17 GPI0	17	17
18 GPO1	# 18 GPI1	18	18
19 GPO2	# 19 GPI2	19	19
20 GPO3	# 20 GPI3	20	20
21 -----	21 -----	21	21
22 -----	22 -----	22	22
23 -----	23 -----	23	23
24 -----	24 -----	24	24
25 -----	25 -----	25	25
26 -----	26 -----	26 GND-----	# 26 -----
27 -----	27 -----	27 GND-----	# 27 -----
28 -----	28 -----	28 -----	28 -----
29 -----	29 -----	29 -----	29 -----
30 -----	30 -----	30 -----	30 -----
31 -----	31 -----	31 -----	31 -----
32 -----	32 -----	32 -----	32 -----
33 -----	33 -----	33 -----	33 -----
34 -----	34 -----	34 -----	34 -----
35 -----	35 -----	35 -----	35 -----
36 -----	36 -----	36 -----	36 -----
37 -----	37 -----	37 -----	37 -----
38 -----	38 -----	38 -----	38 -----
39 -----	39 -----	39 -----	39 -----
40 -----	40 -----	40 -----	40 -----
		41 -----	41 -----
		42 -----	42 -----
		43 -----	43 -----
		44 -----	44 -----
		45 -----	45 -----
		46 -----	46 -----
		47 -----	47 -----
		48 -----	48 -----
		49 -----	49 -----
		50 -----	50 -----



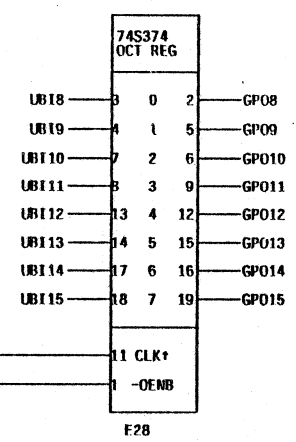
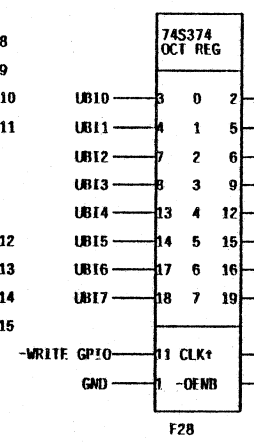
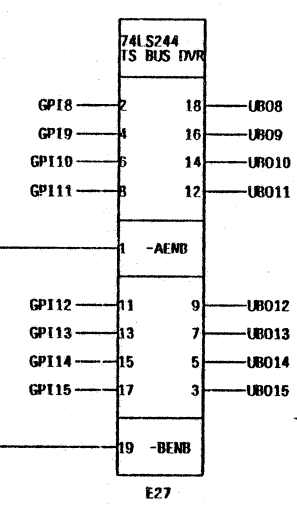
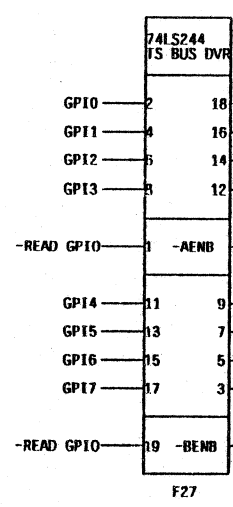
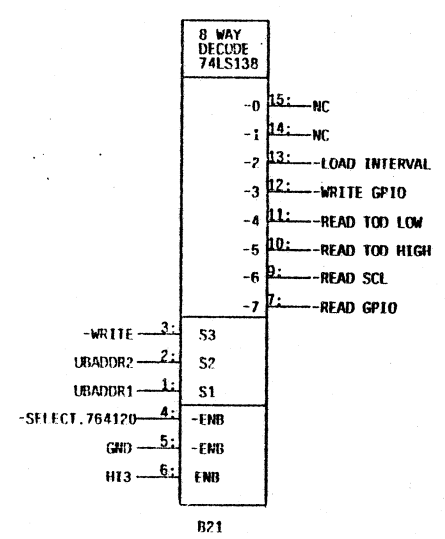
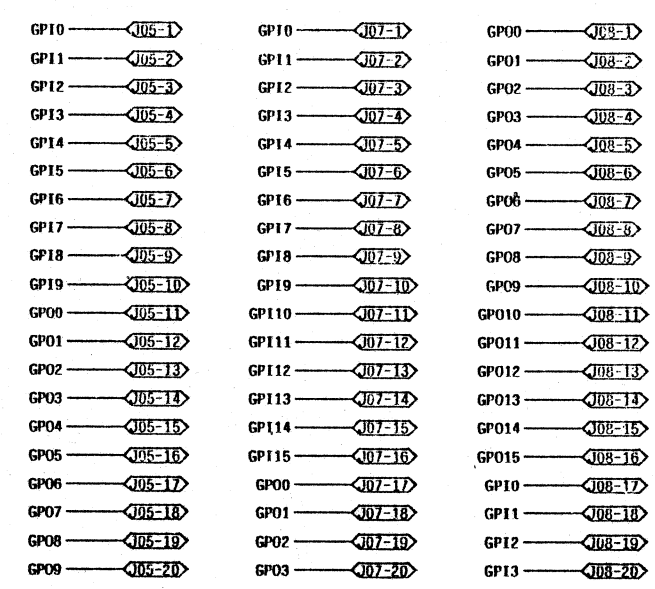
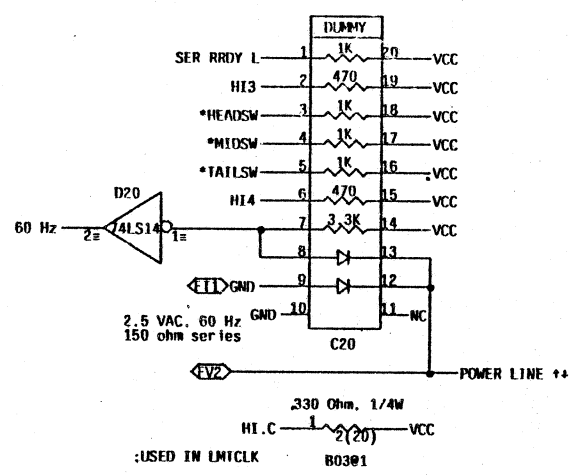
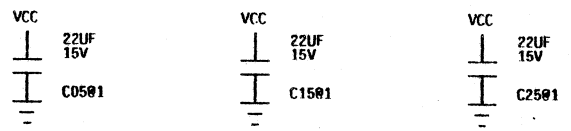

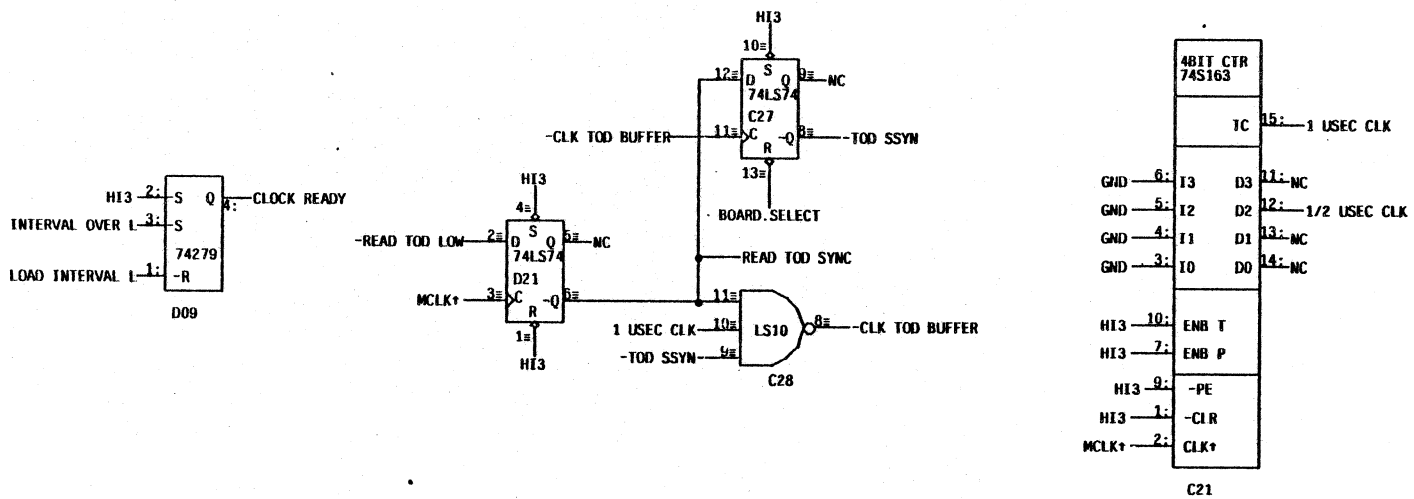
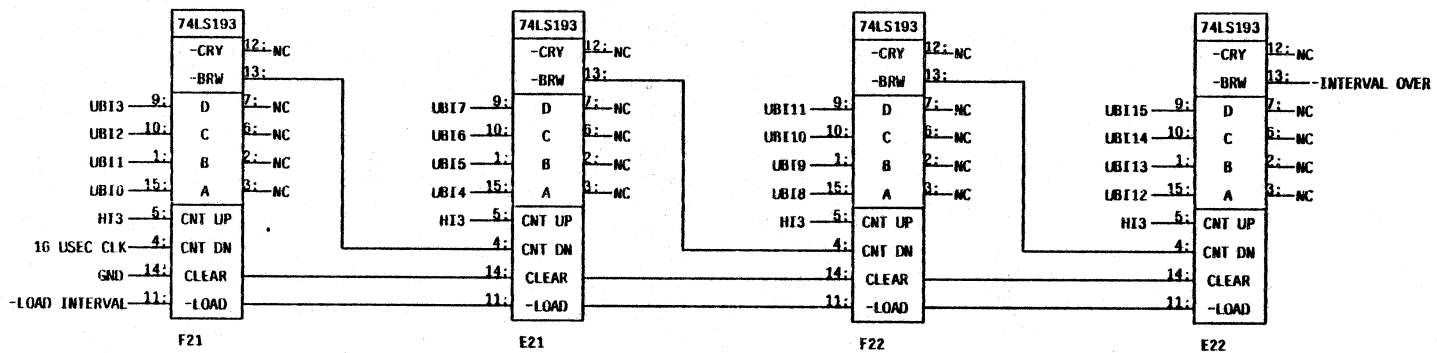



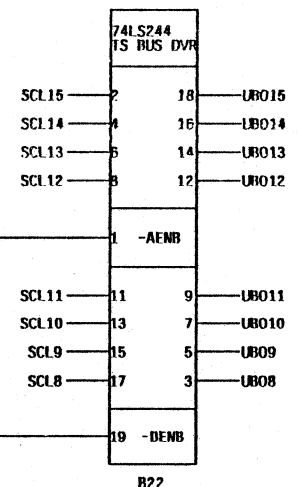
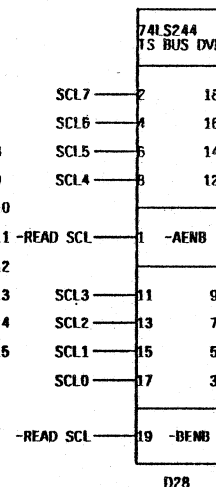
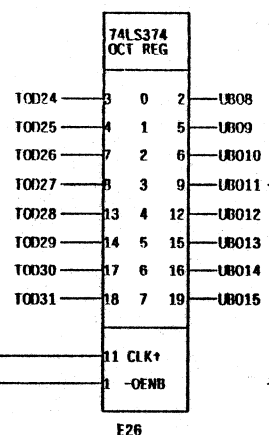
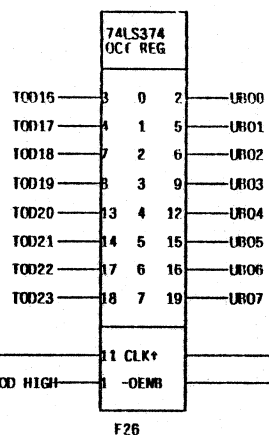
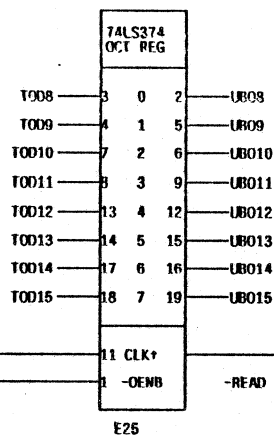
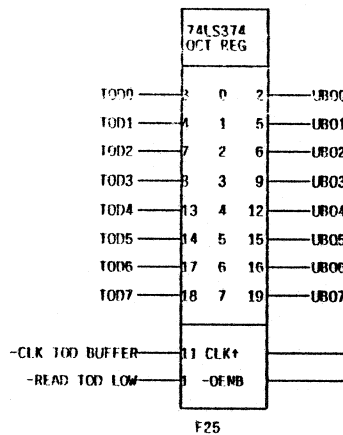
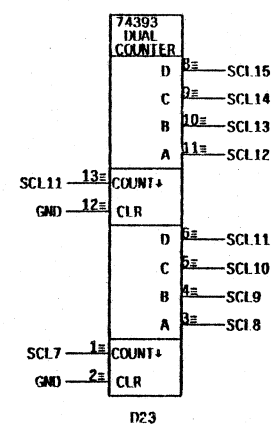
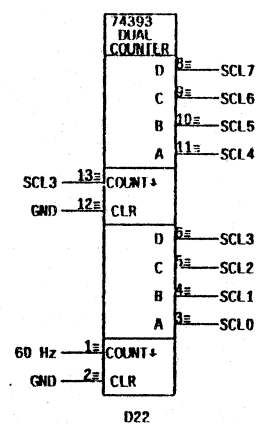
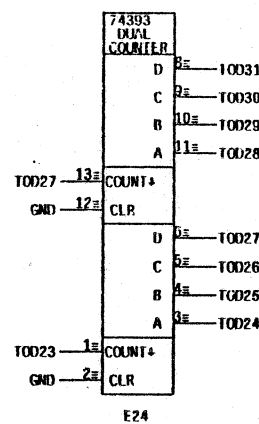
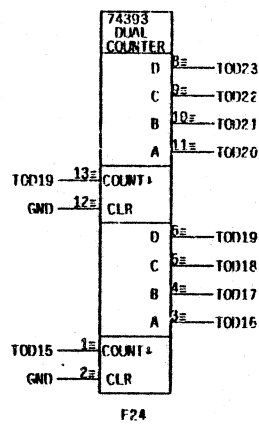
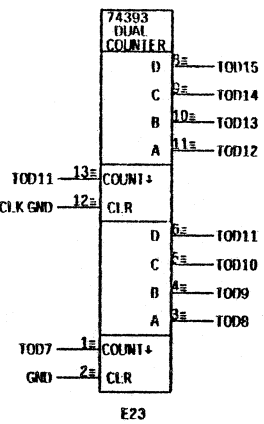
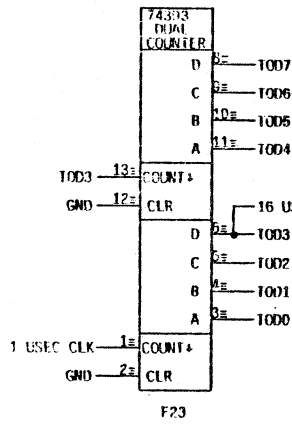

CC2 — GND  
 CF1 — NC  
 CN1 — NC  
 CI1 — GND  
 DC2 — GND  
 DF1 — NC  
 DN1 — NC  
 DI1 — GND  
 EA1 — GND  
 EC2 — GND  
 EM2 — GND  
 EN1 — GND  
 ES2 — GND  
 FI1 — GND  
 FC2 — GND  
 FF1 — NC  
 FH1 — NC  
 FI1 — GND

CB2 — -5V  
 DB2 — -5V  
 EB2 — -5V  
 FB2 — -5V

GA2 — +5V  
 HA2 — +5V  
 IA2 — +5V  
 JA2 — +5V

KS2 — -D0\*  
 KB2 — -D1\*  
 KP2 — -D2\*  
 KT2 — -D3\*  
 KU2 — -D4\*  
 KV2 — -D5\*  
 KW2 — -D6\*  
 KX2 — -D7\*  
 KY2 — -D8\*  
 KZ2 — -D9\*  
 LA2 — -D10\*  
 LB2 — -D11\*  
 LC2 — -D12\*  
 LD2 — -D13\*  
 LE2 — -D14\*  
 LF2 — -D15\*  
 EE1 — -MSYN\*  
 EH1 — -SSYN\*  
 EJ2 — -C0\*  
 EK2 — -C1\*

EH2 — -A0\*  
 EH1 — -A1\*  
 EE1 — -A2\*  
 EV2 — -A3\*  
 EU2 — -A4\*  
 EV1 — -A5\*  
 EU1 — -A6\*  
 EP2 — -A7\*  
 EN2 — -A8\*  
 EH1 — -A9\*  
 EP1 — -A10\*  
 EL1 — -A11\*  
 EC1 — -A12\*  
 EK2 — -A13\*  
 EL1 — -A14\*  
 ED2 — -A15\*  
 EE2 — -A16\*  
 ED1 — -A17\*  
 EP1 — -BOOT\*

GA1 — -NPG. IN\*  
 GB1 — -NPG. OUT\*  
 GD2 — -BR7\*  
 GE2 — -BR6\*  
 GF2 — -BR5\*  
 GH2 — -BR4\*  
 GI1 — -INIT\*  
 GK2 — -BG7. IN\*  
 GL2 — -BG7. OUT\*  
 GM2 — -BG6. IN\*  
 GN2 — -BG6. OUT\*  
 OP2 — -BG5. IN\*  
 OR2 — -BG5. OUT\*  
 OS2 — -BG4. IN\*  
 OT2 — -BG4. OUT\*  
 ED1 — -BBSY\*  
 EJ1 — -NPR\*  
 EH1 — -INTR\*  
 ET2 — -SACK\*

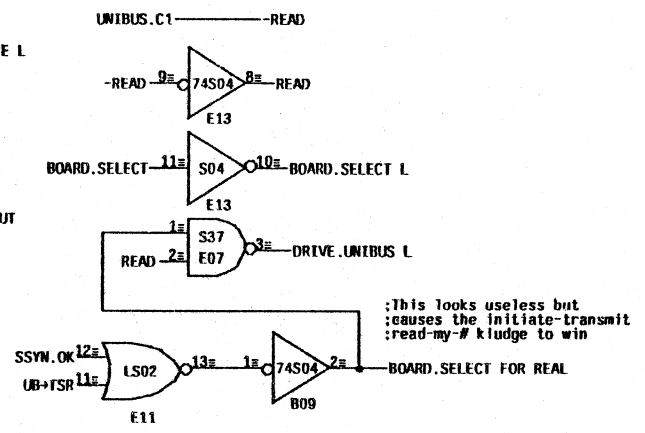
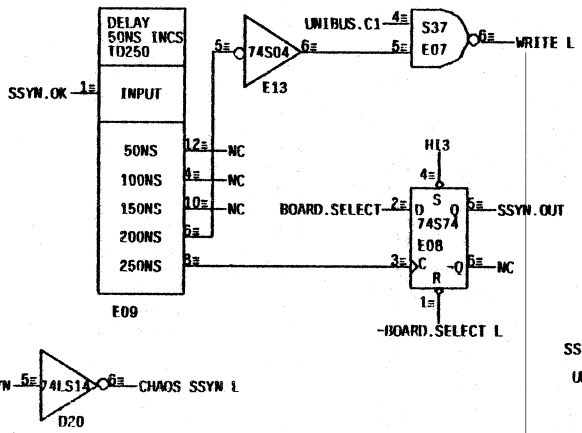
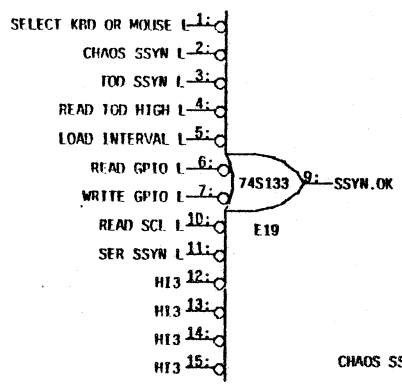
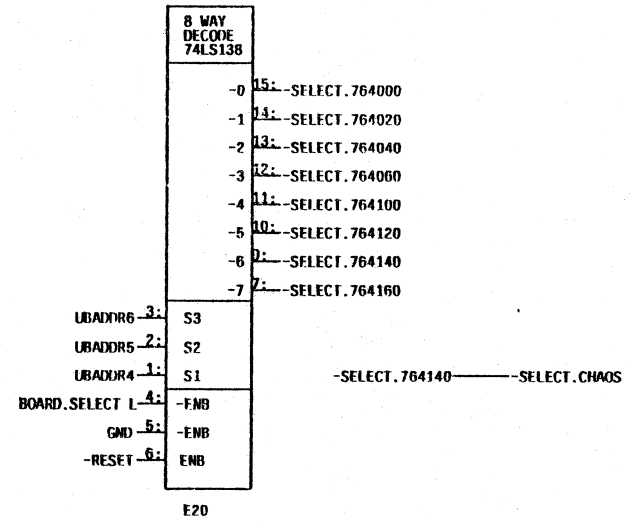
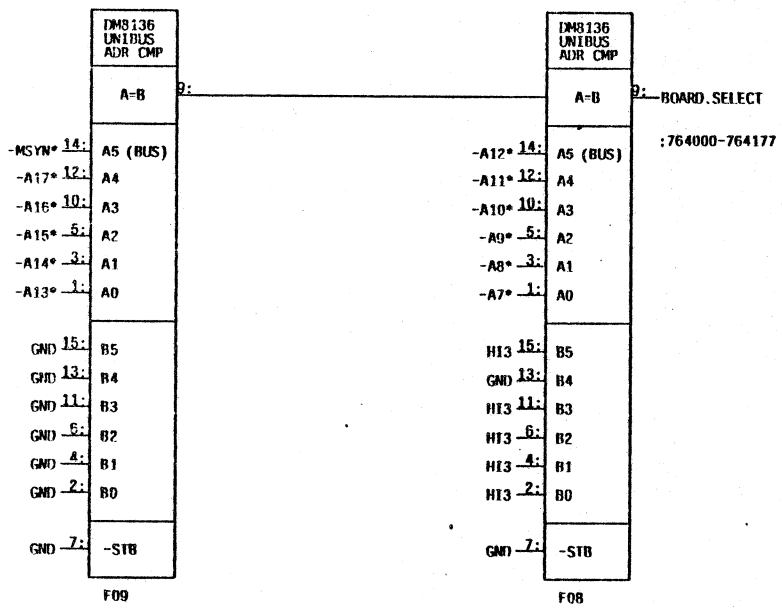

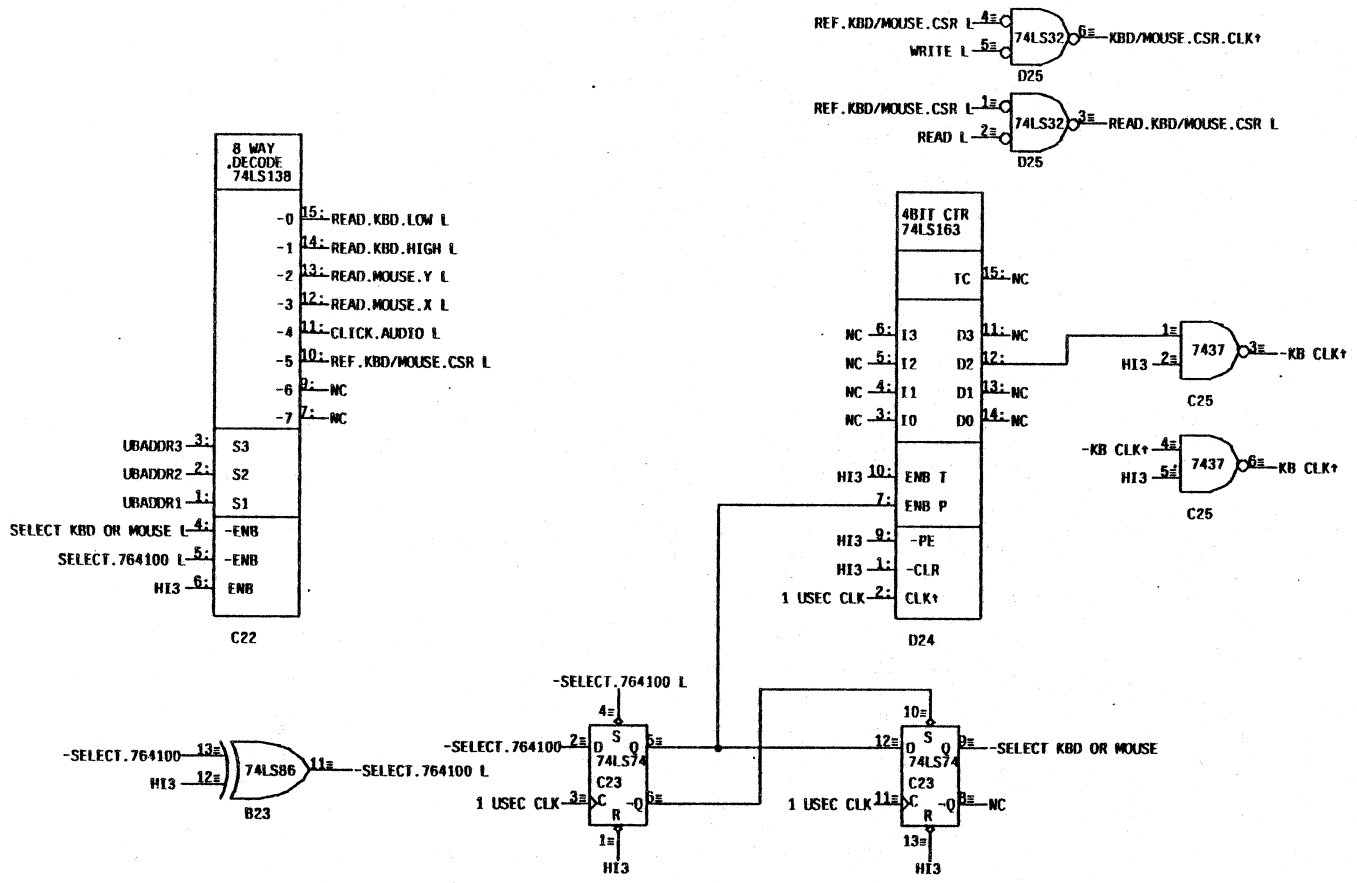

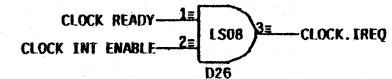
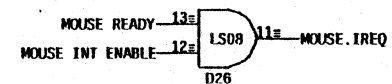
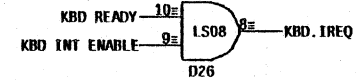
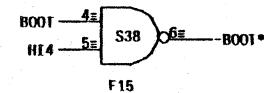
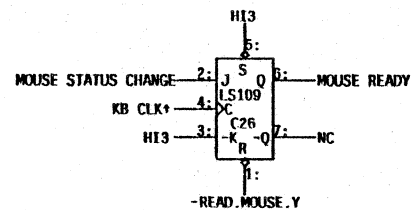
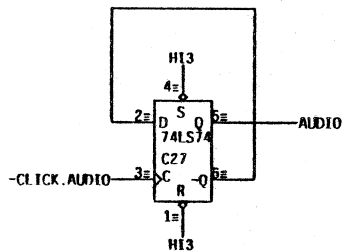
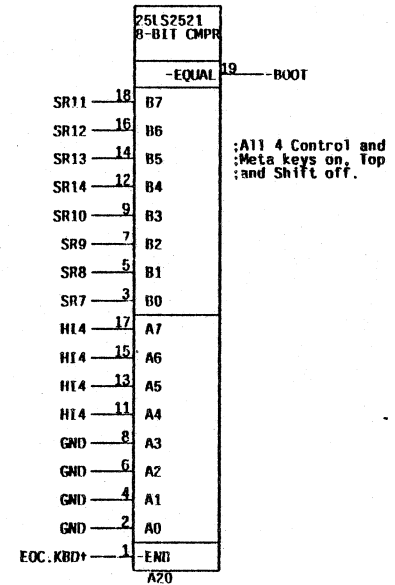
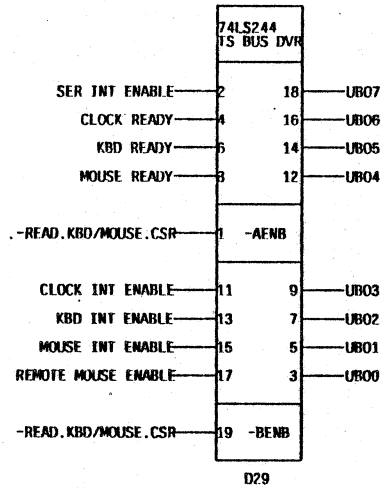
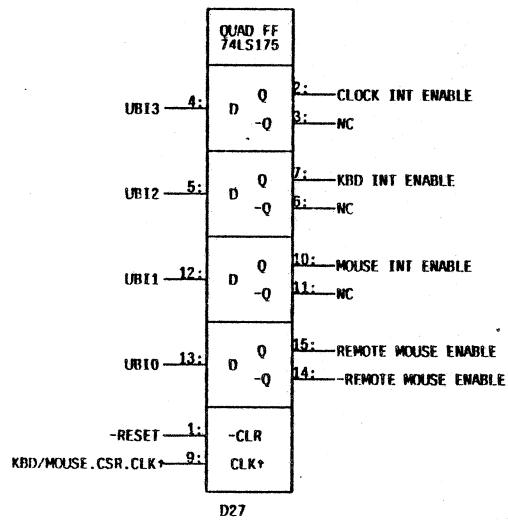



GND	→	J01-1		J01-26	→	GND
INTERFERE+	→	J01-2		J01-27	→	GND
INTERFERE-	→	J01-3		J01-28	→	GND
GND	→	J01-4		J01-29	→	GND
RCVR.DATA+	→	J01-5		J01-30	→	GND
RCVR.DATA-	→	J01-6		J01-31	→	GND
GND	→	J01-7		J01-32	→	GND
TRANS.DATA+	→	J01-8		J01-33	→	GND
TRANS.DATA-	→	J01-9		J01-34	→	GND
GND	→	J01-10		J01-35	→	GND

Console Cable

:DECOMMIT J3-23.30.31.32  
:THEN USE TWISTED-PAIR WIRING

- Q3-10 → AUDIO+ \*
- Q3-20 → AUDIO- \*
- Q3-11 → KBDCLK+ \*
- Q3-21 → KBDCLK- \*
- Q3-12 → KBDIN+ \*
- Q3-22 → KBDIN- \*

- Q1-1 → H SYNC
- Q1-2 → V SYNC
- Q3-3 → MECL VIDEO+
- Q3-4 → MECL VIDEO-

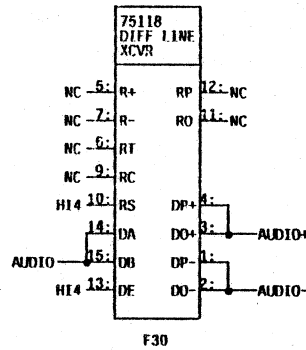
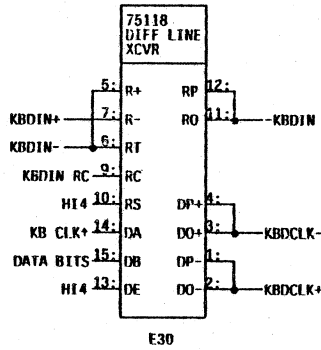
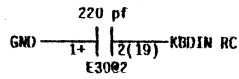

:KBDIN GOES LOW TO START

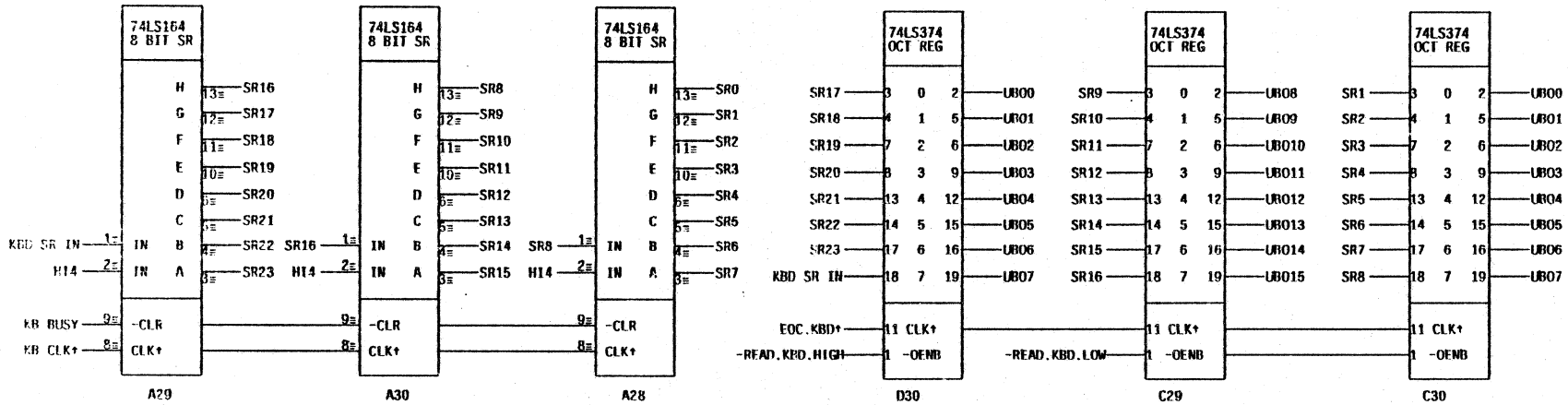
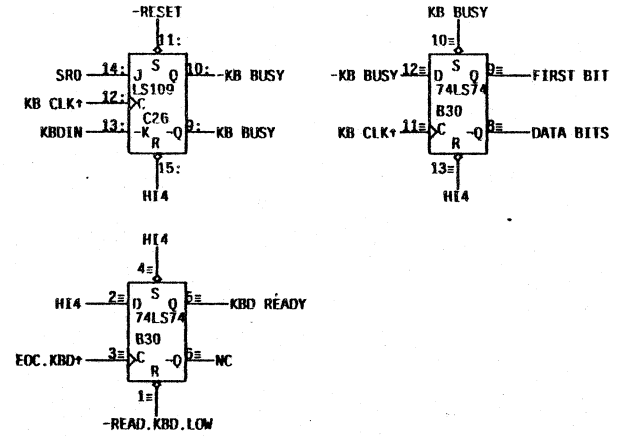
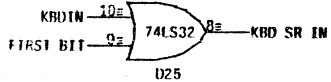
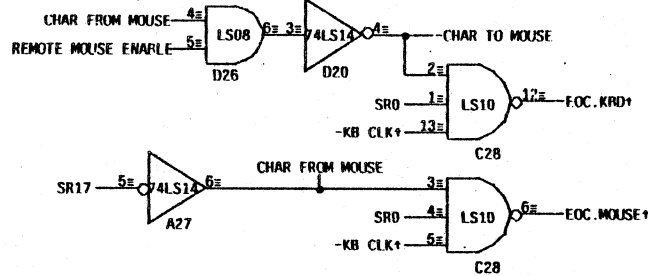
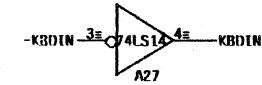



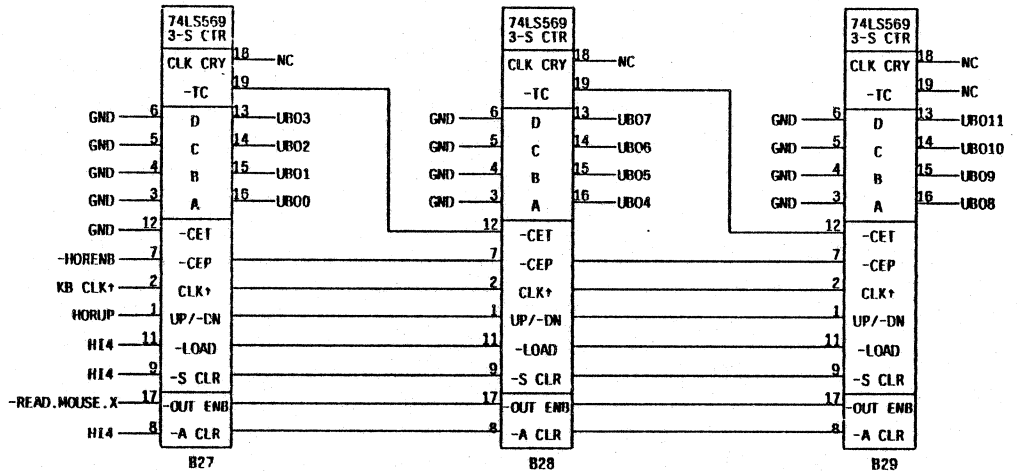
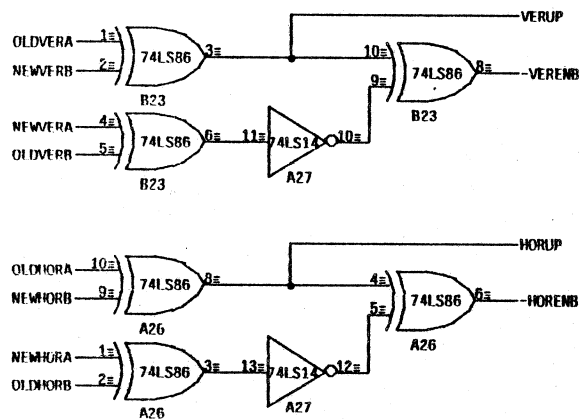
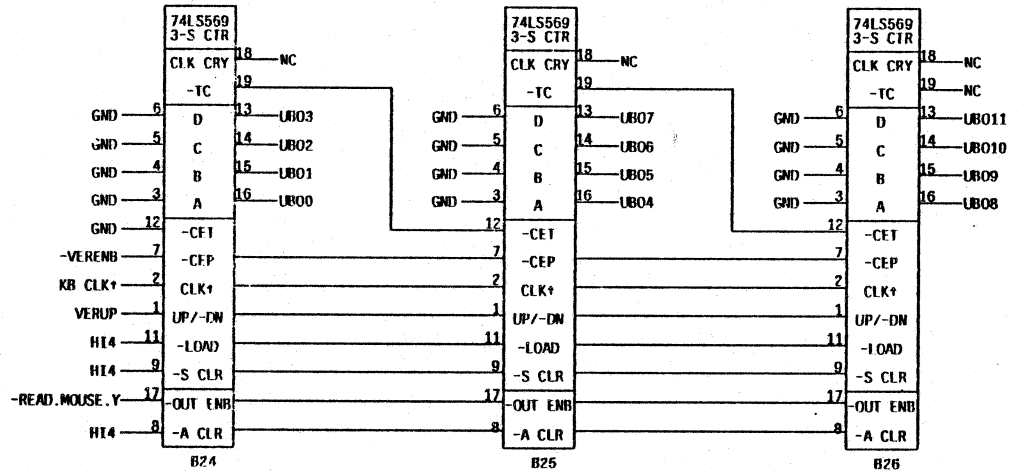
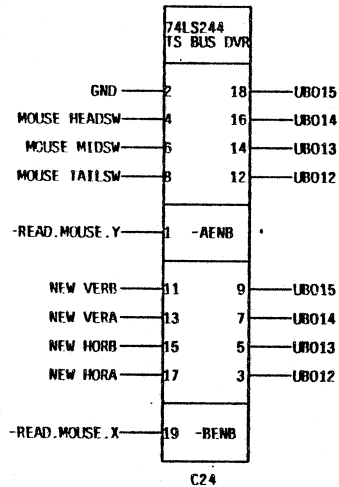

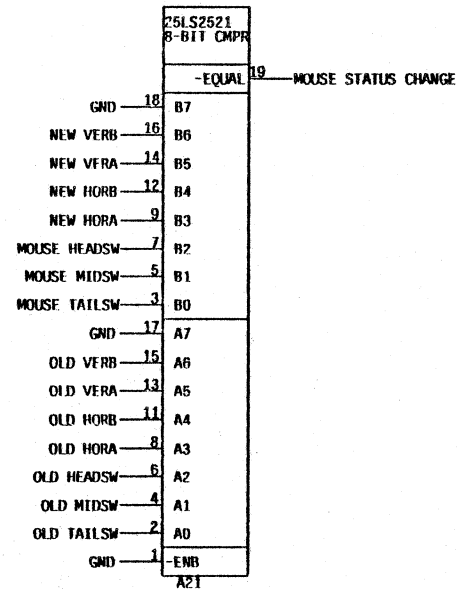
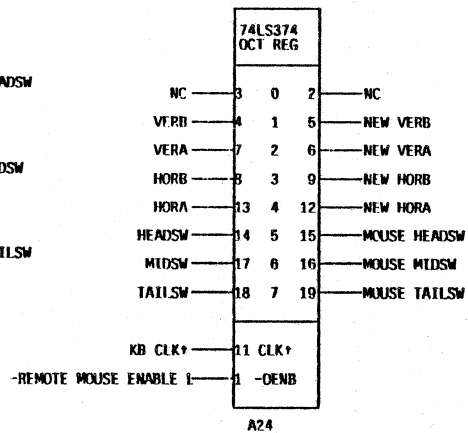
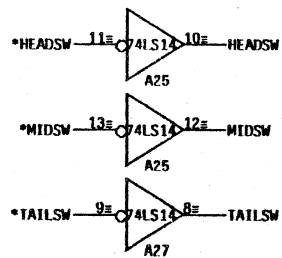
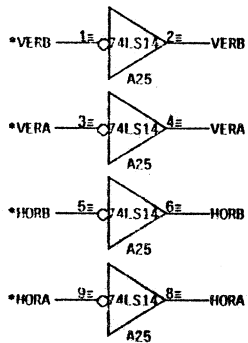
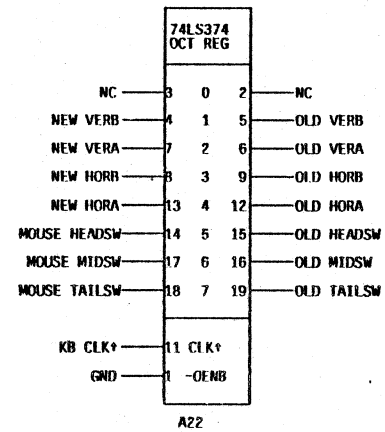
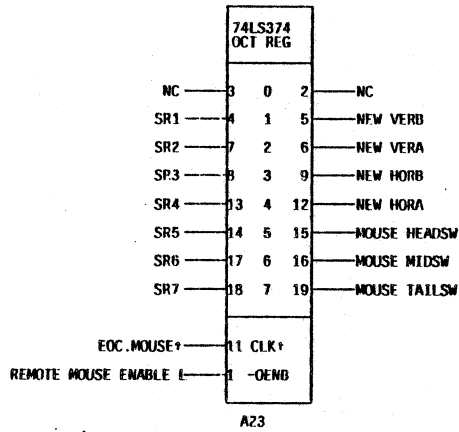
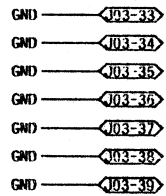
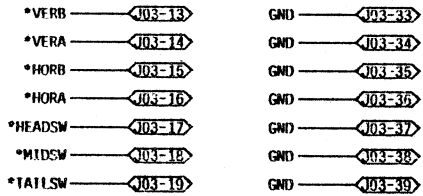

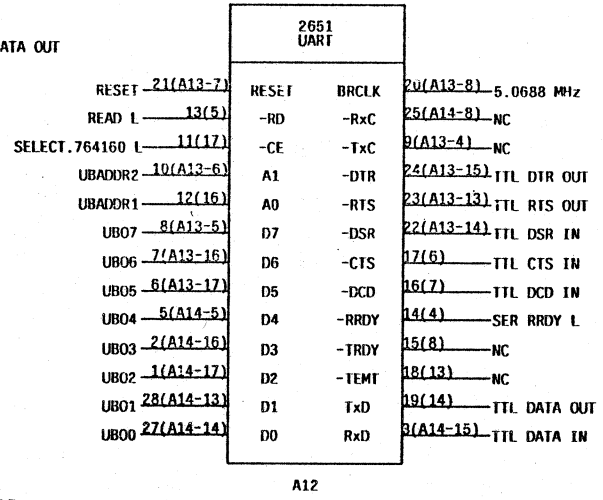
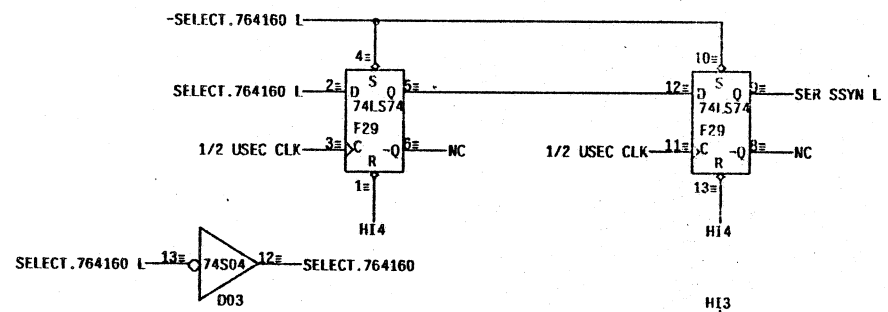
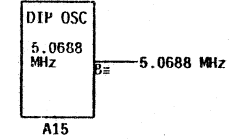
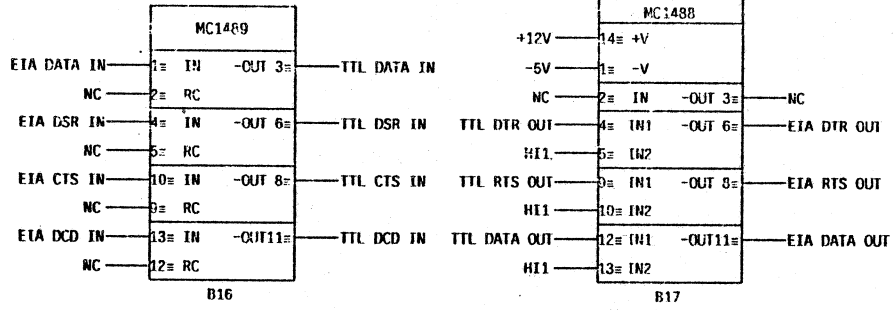

**RS-232 CONNECTOR**

TERMINAL	NUMBER	TYPE	MODEM	Signal
2	3	♀	♂	J09-1 EIA DATA OUT
3	2	♀	♂	J09-2 EIA DATA IN
4	5	♀	♂	J09-3 EIA RTS OUT
5	4	♀	♂	J09-4 EIA CTS IN
6	20	♀	♂	J09-5 EIA DSR IN
8	8,20	♀	♂	J09-6 EIA DCD IN
20	6	♀	♂	J09-7 EIA DTR OUT
1	1	♀	♂	J09-26 GND
7	7	♀	♂	J09-27 GND

female male

:Wire across from Xbus by hand  
 +12V

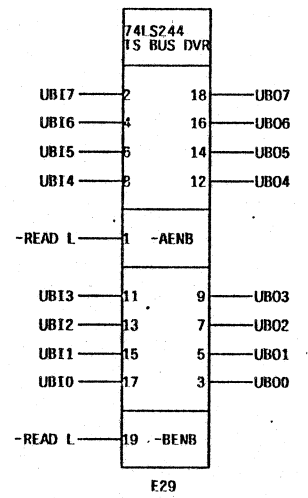
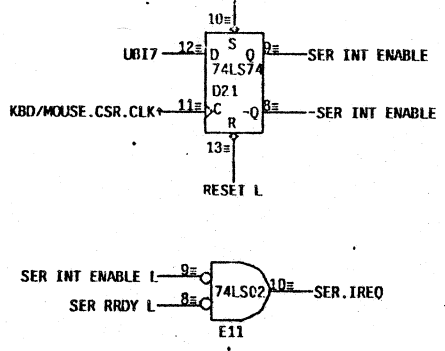

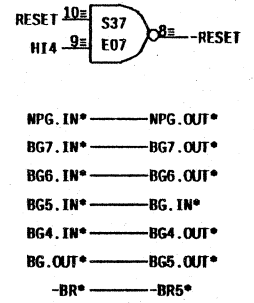
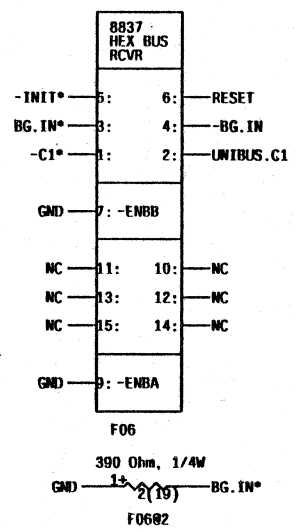
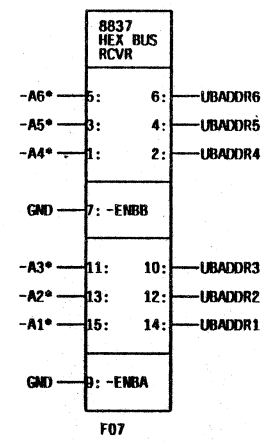
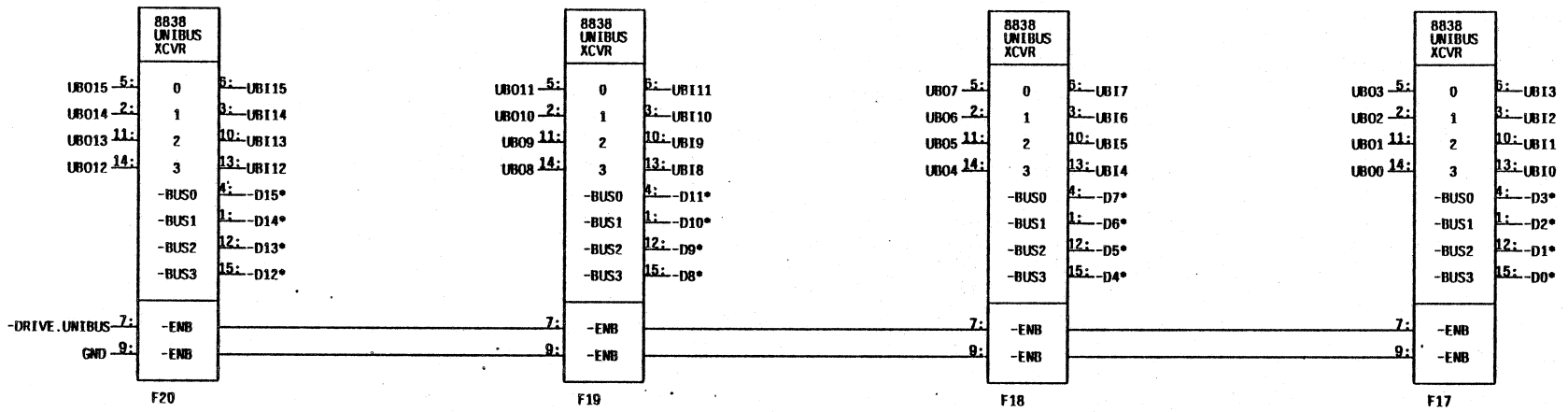

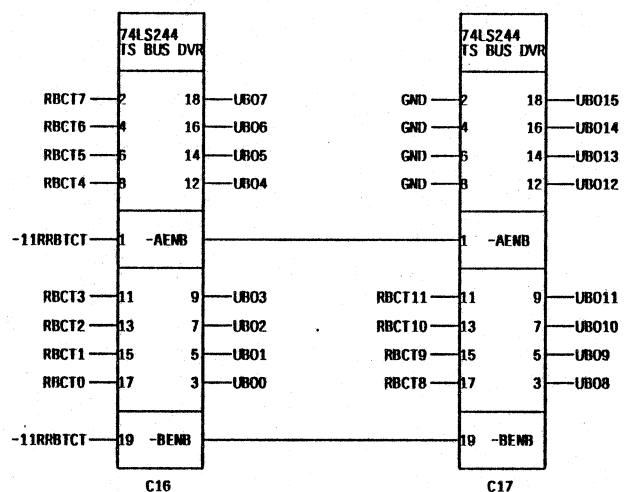
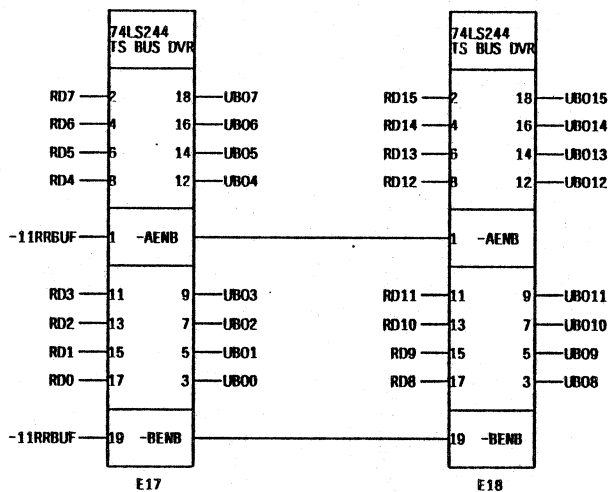
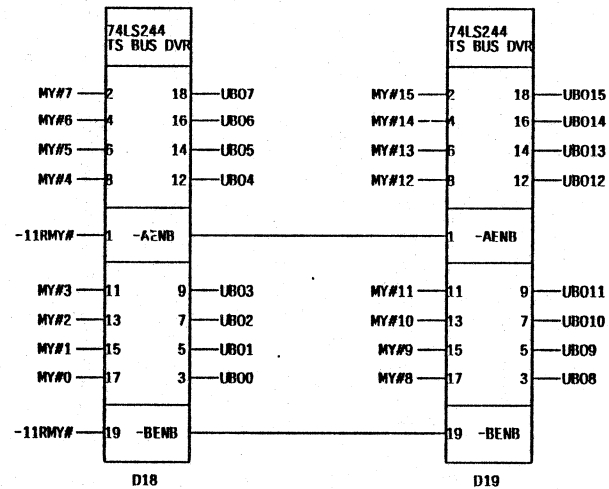
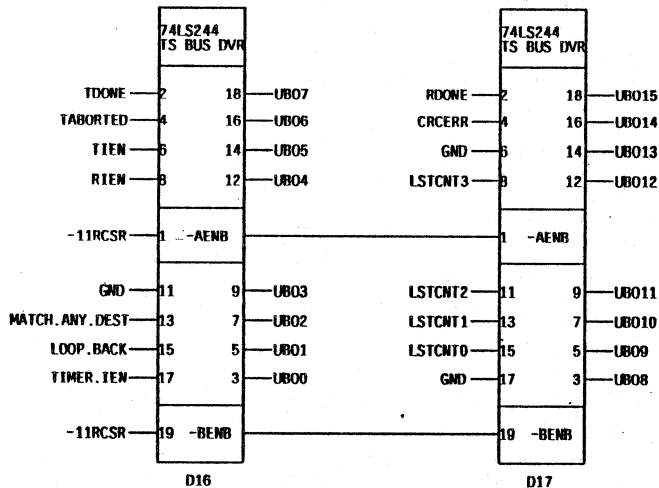

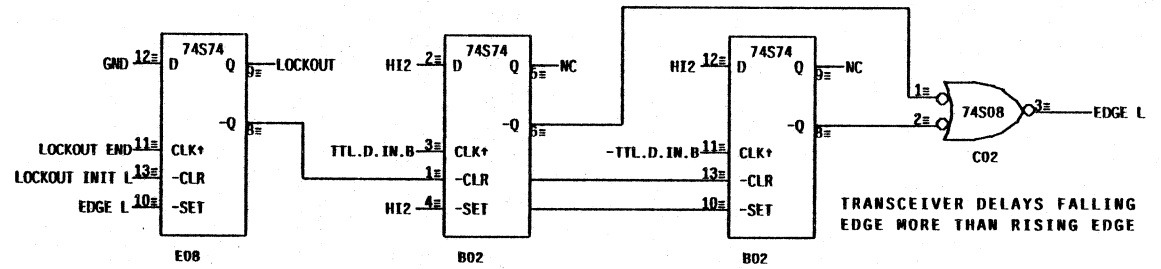
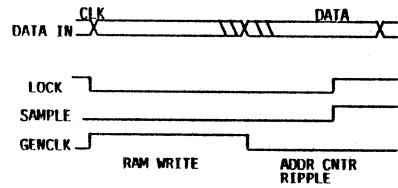

SAMPLE should be timed to occur in the middle of the data part of the cycle. Normally, this will be .75 of the cycle time less 15-25 ns. LOCKOUT END should be 5 ns earlier.

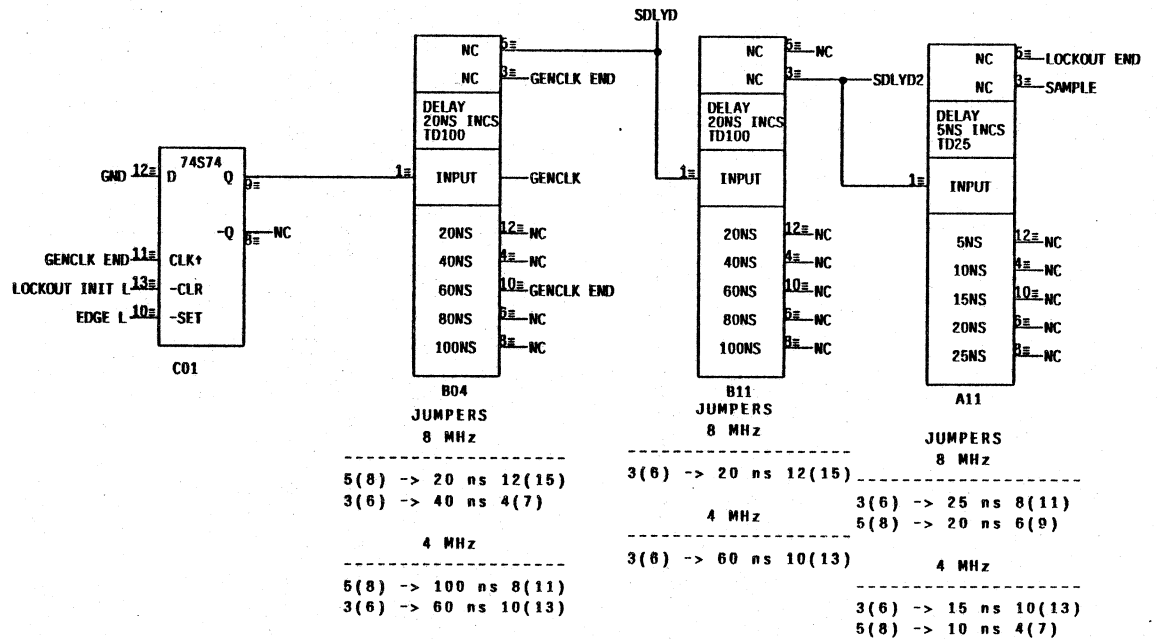
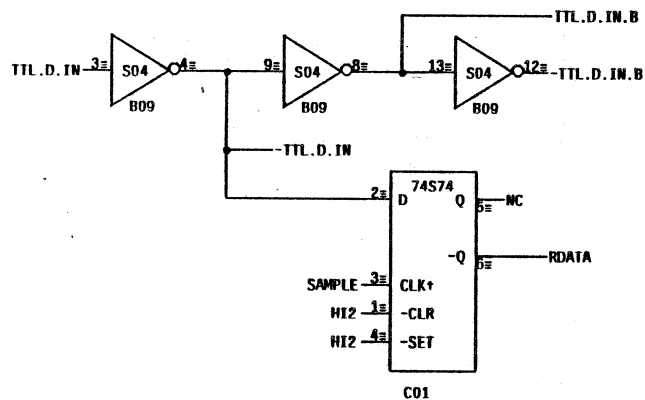
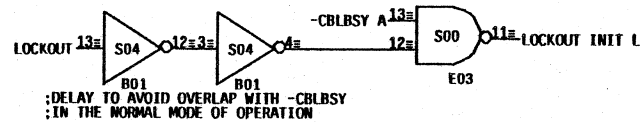

:=26LS32

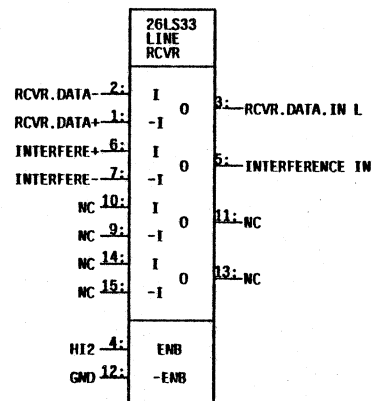

A01

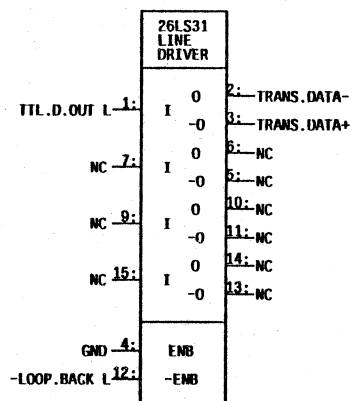

A02

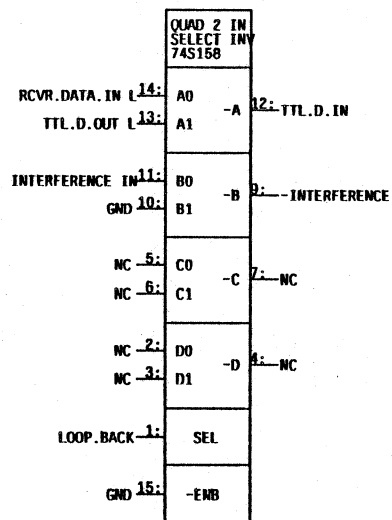

E02

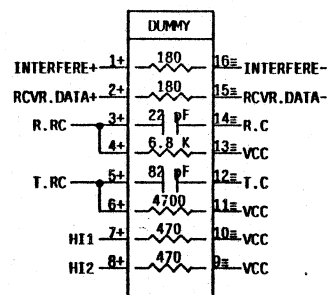

A0302

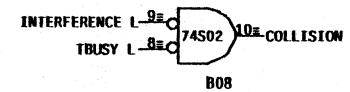
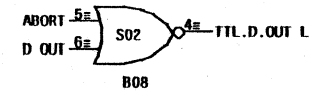
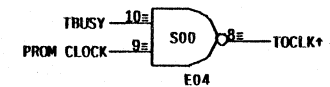
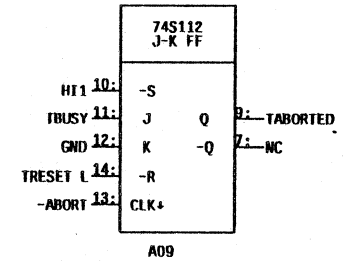
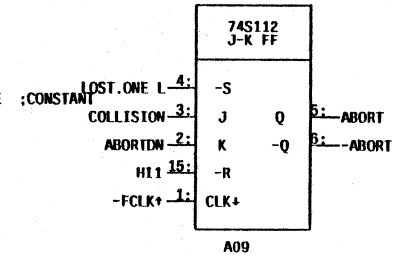
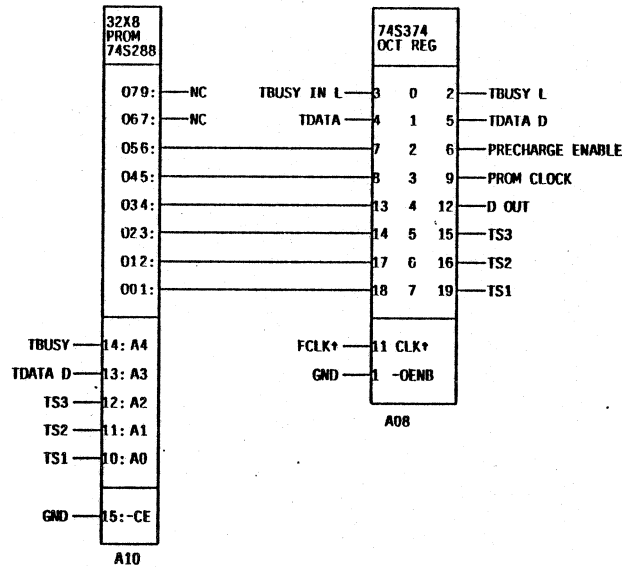
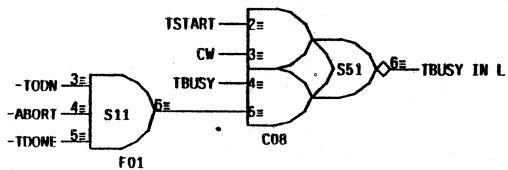
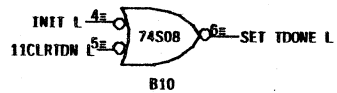
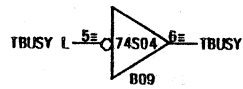
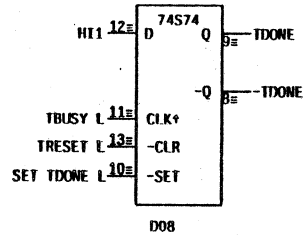
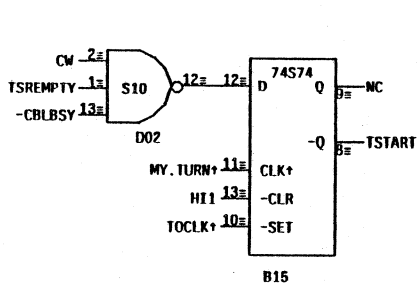



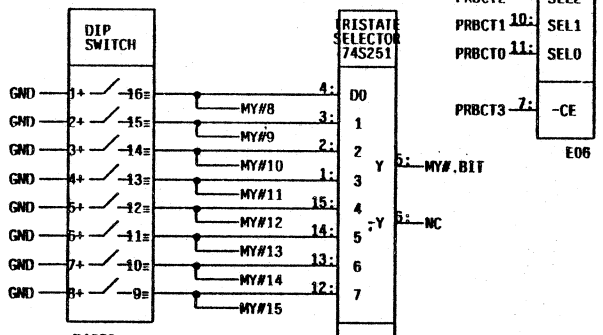
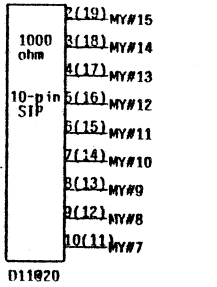
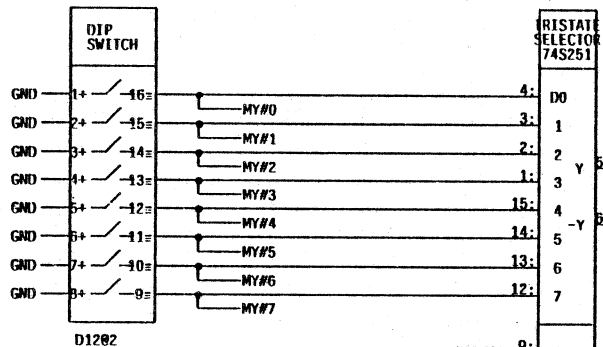
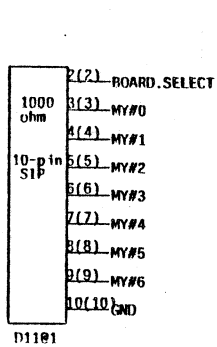

:SIPS are 750-101-R1K

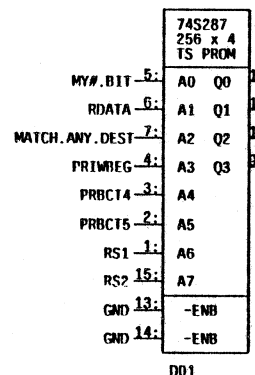

D01

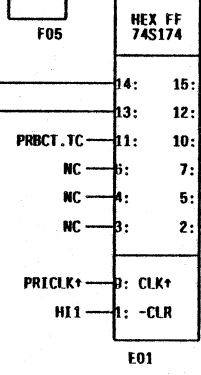

E01

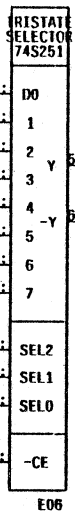

E06

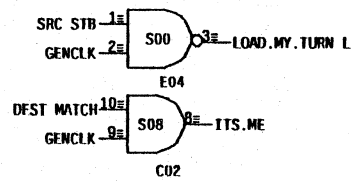
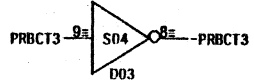

C02

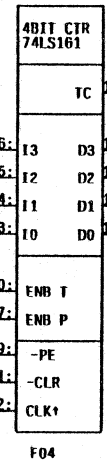

F04

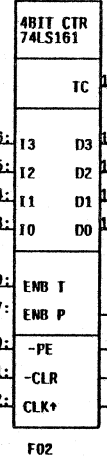

F02

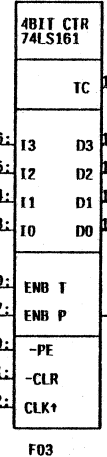

F03

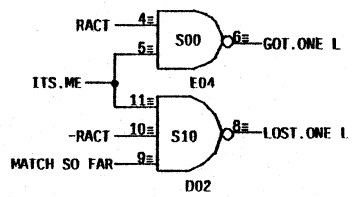

D02

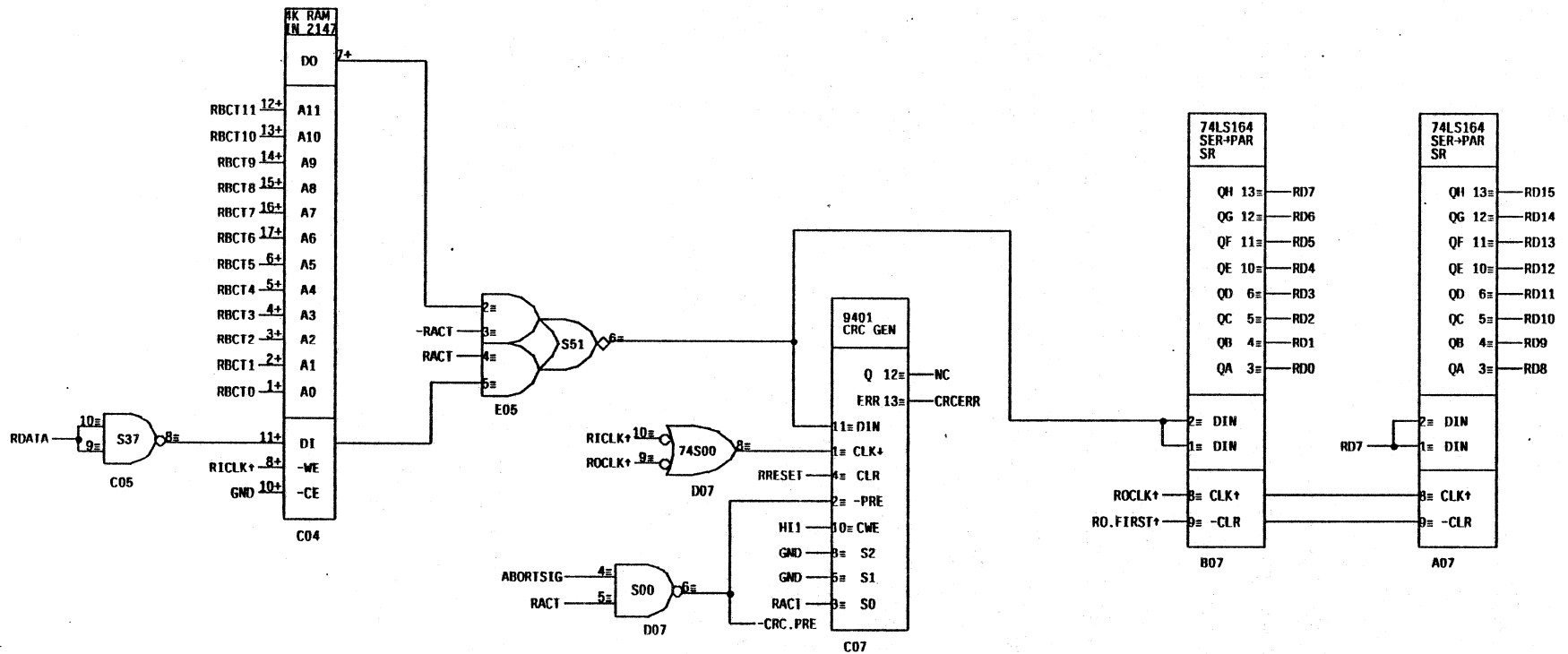
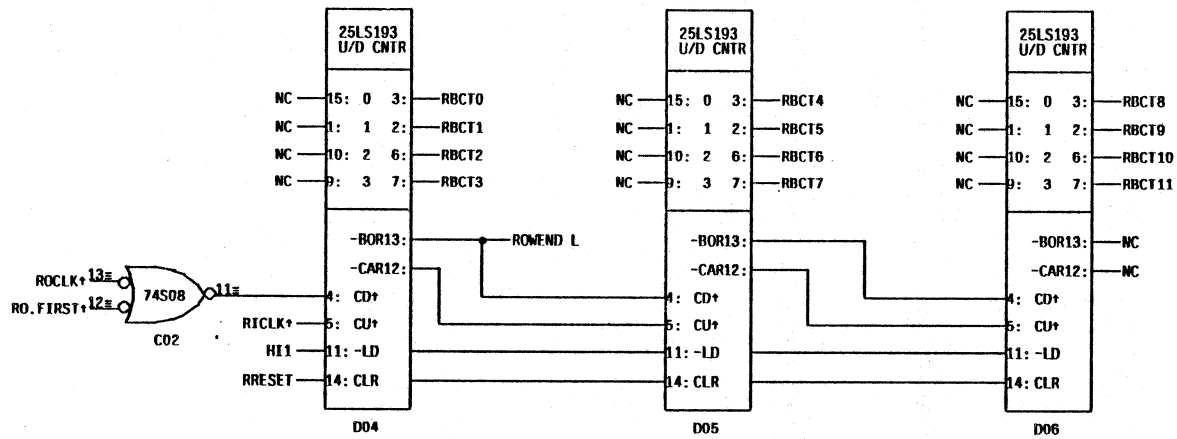

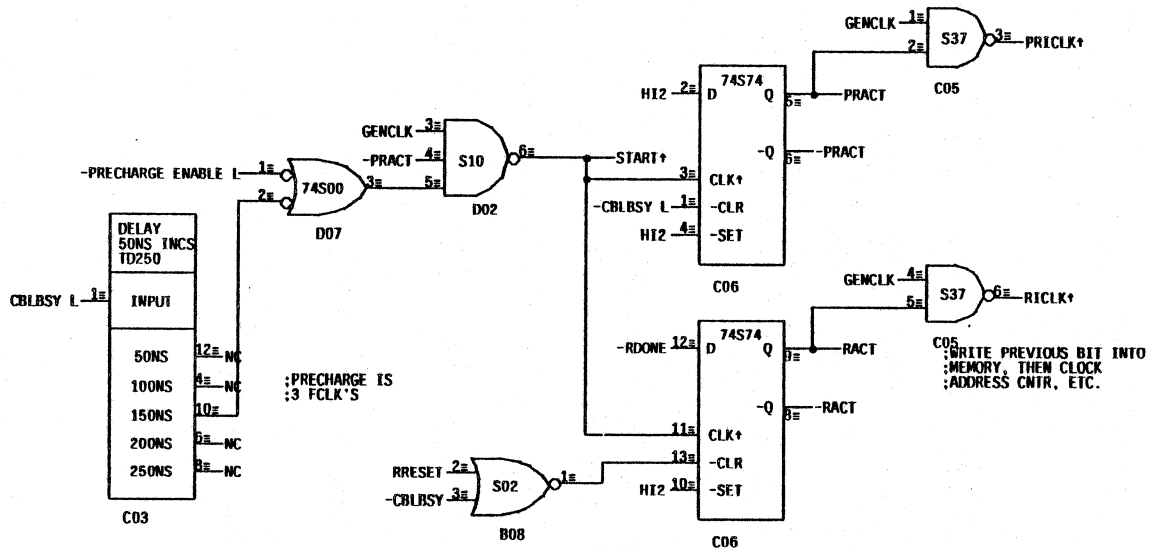
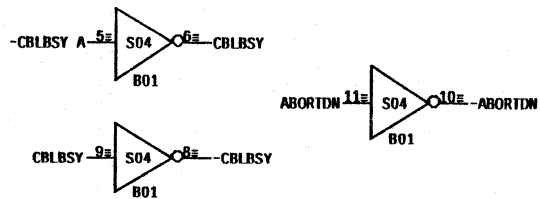
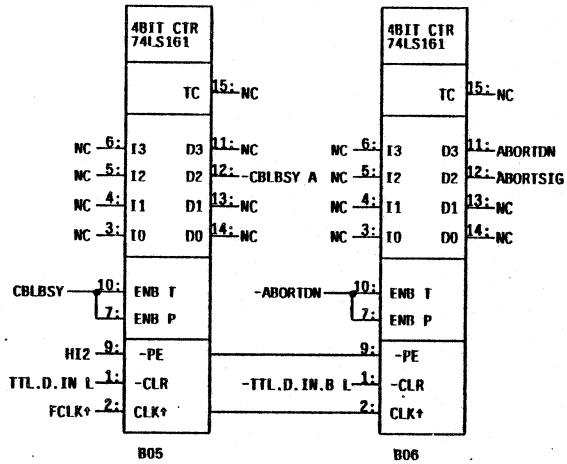

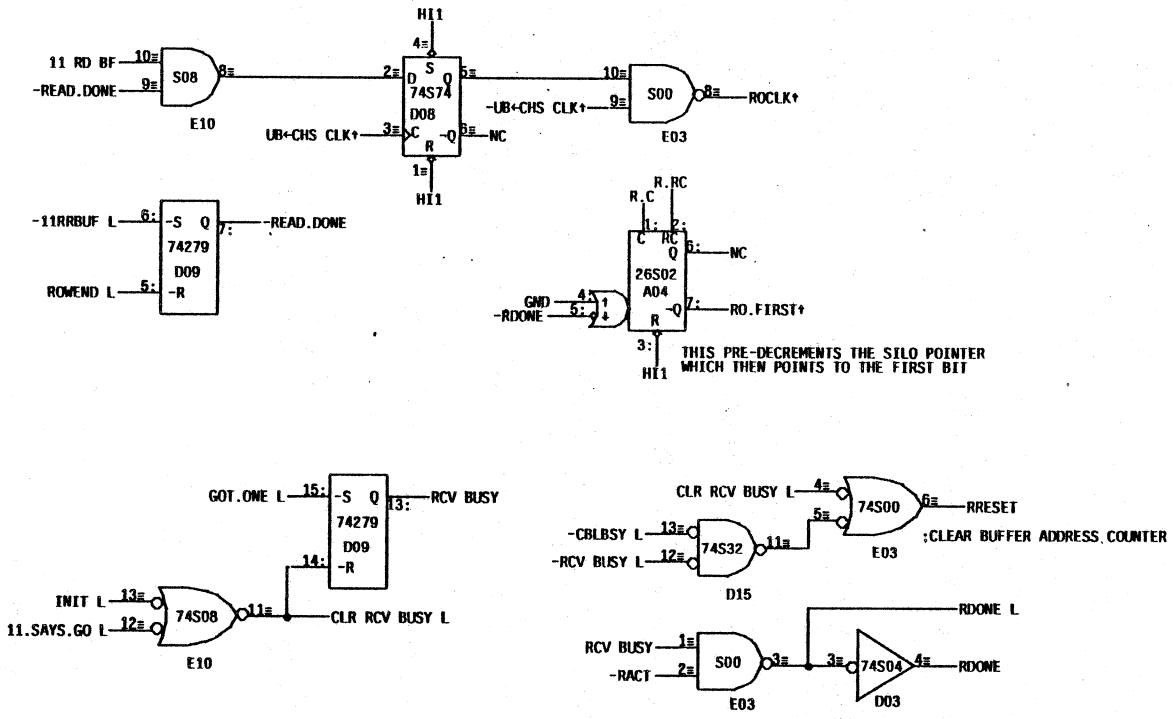

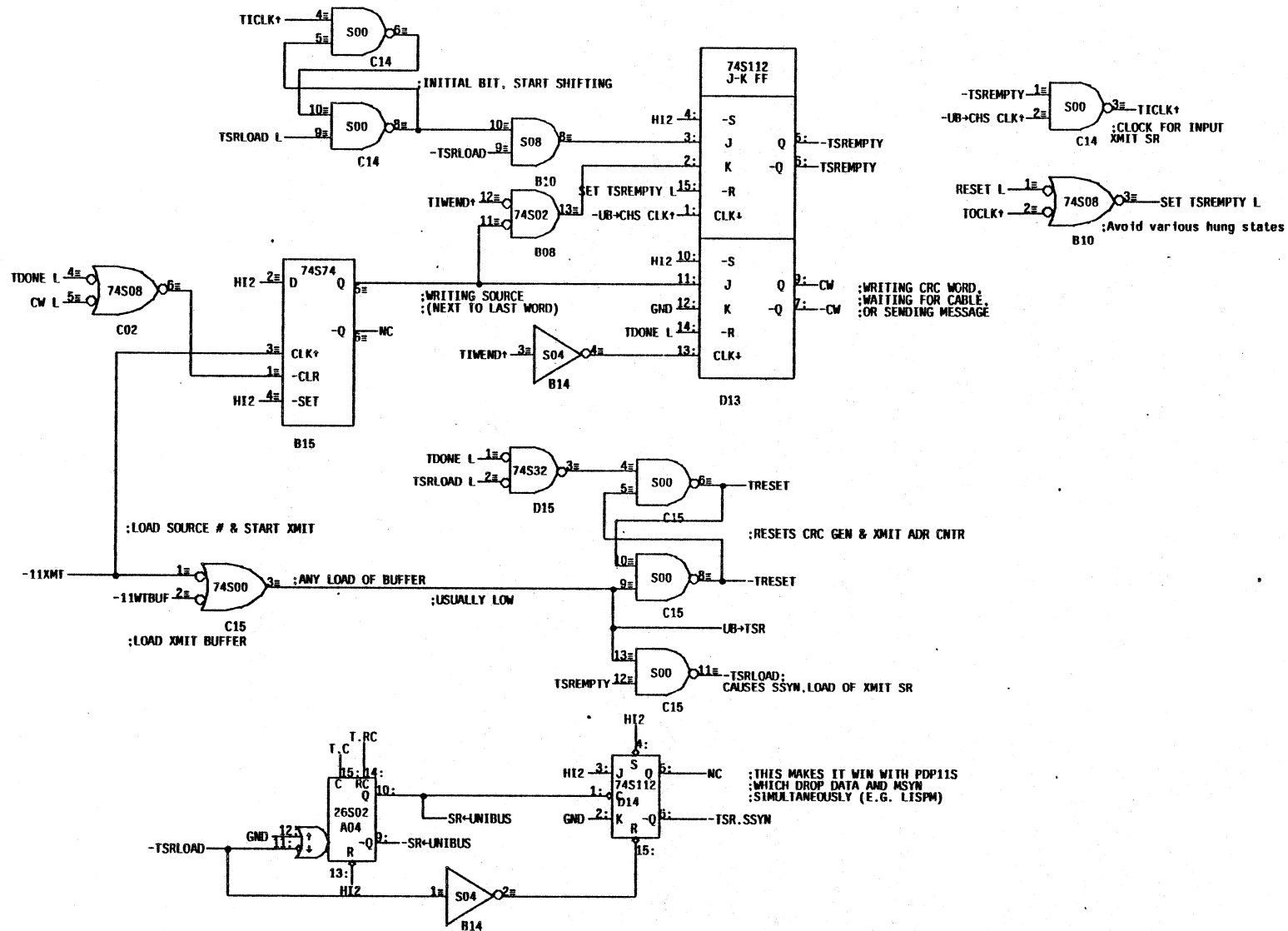

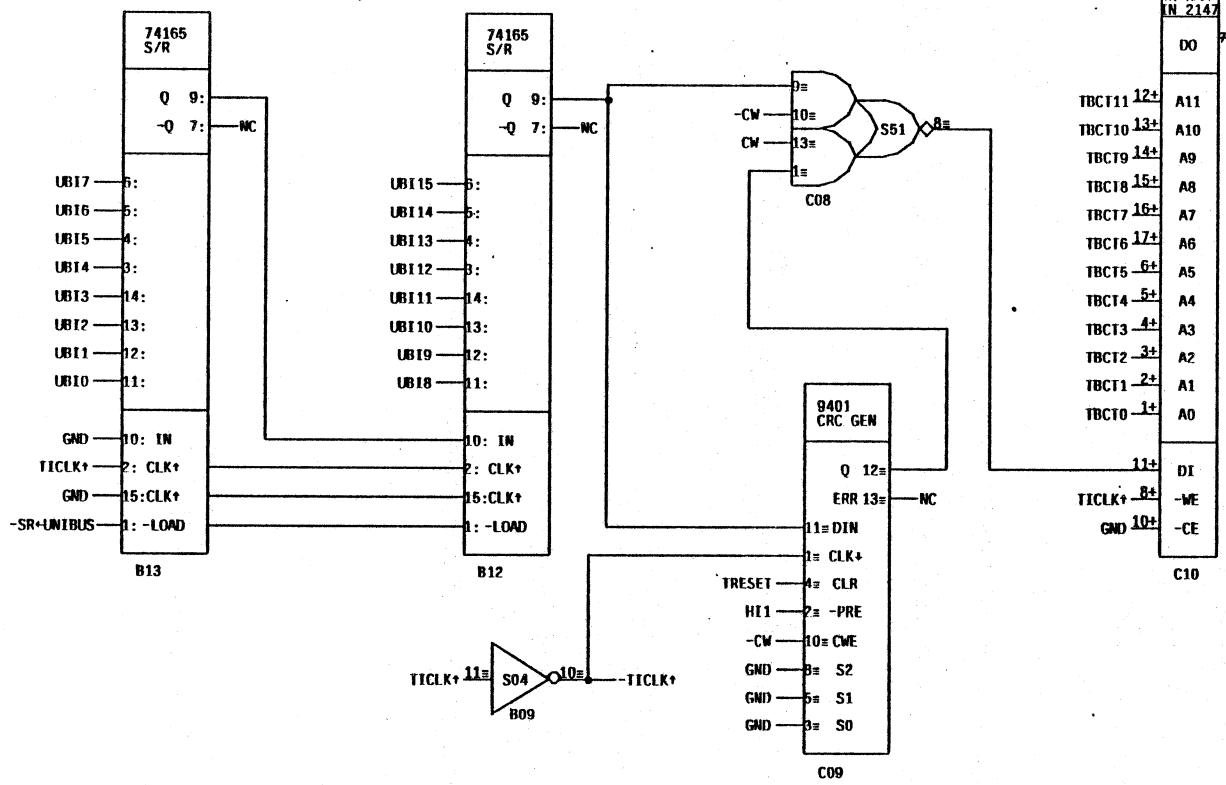
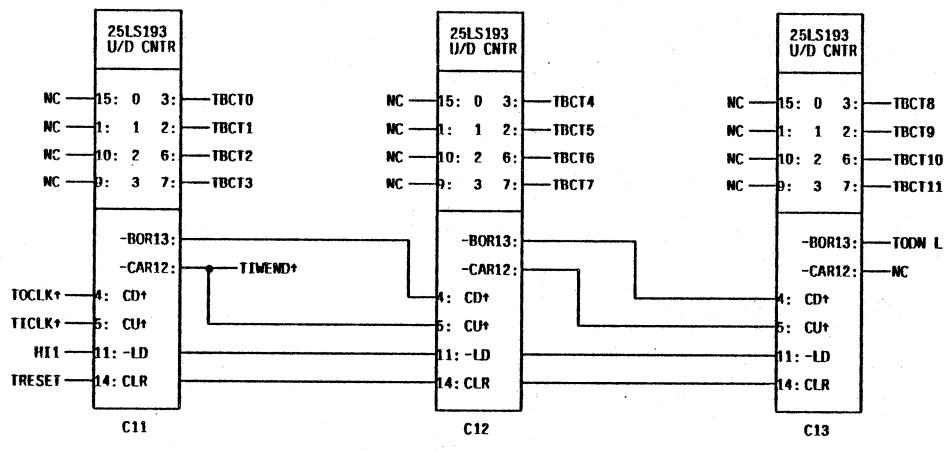

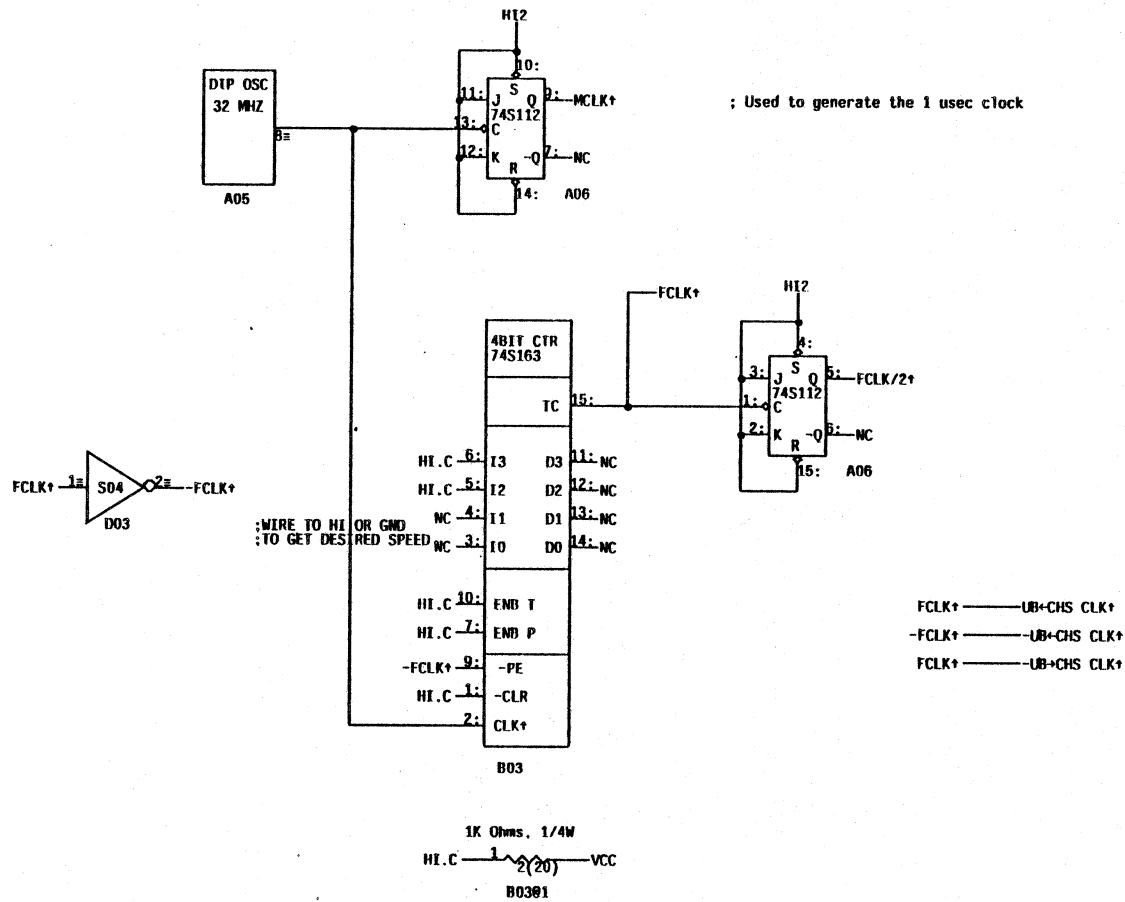

"My Turn" Counter

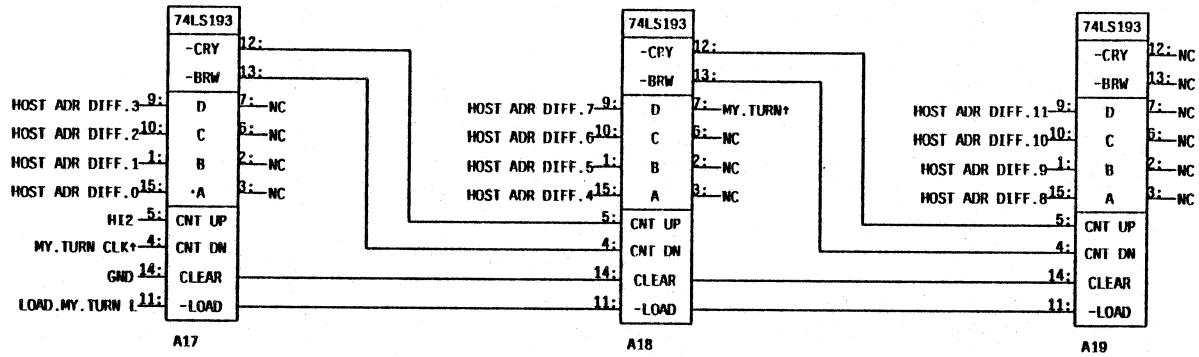

:DEFAULT IS MYTURN.MOD 2+7 OR 64 USECS

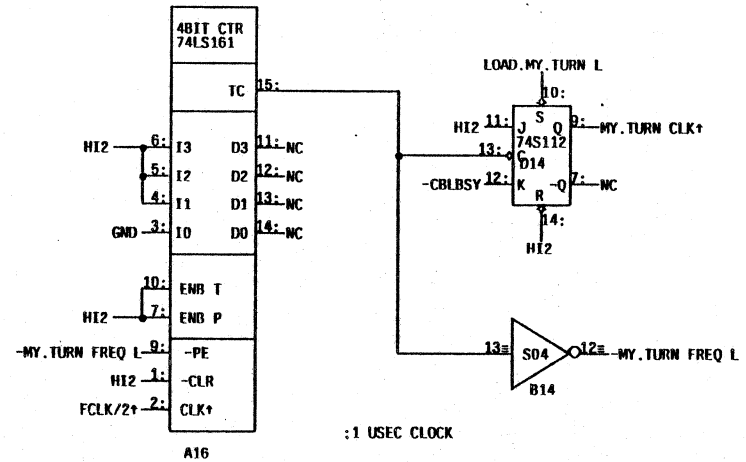
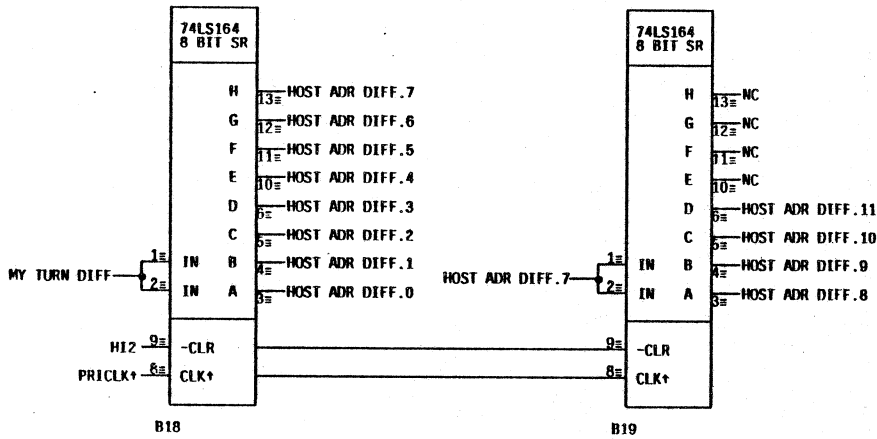

:1 USEC CLOCK



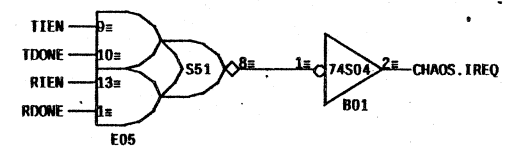
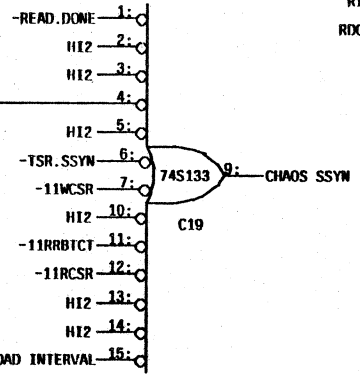
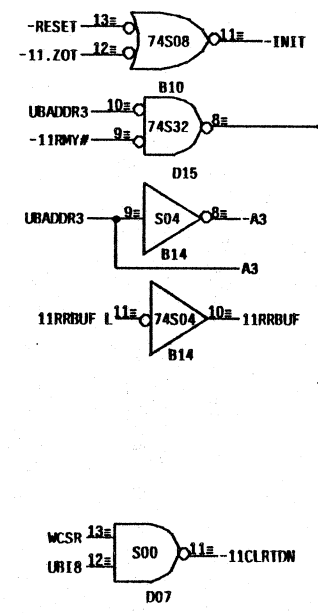
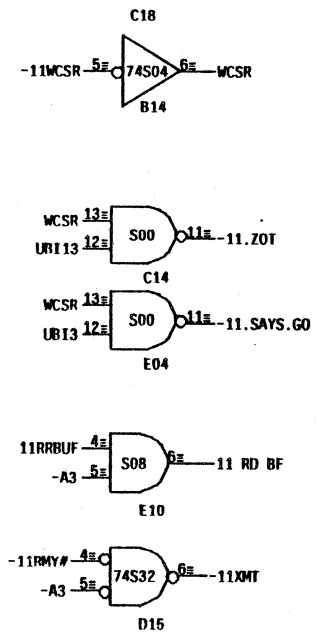
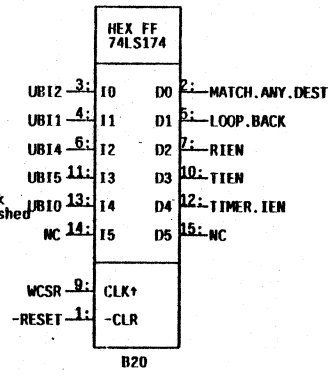
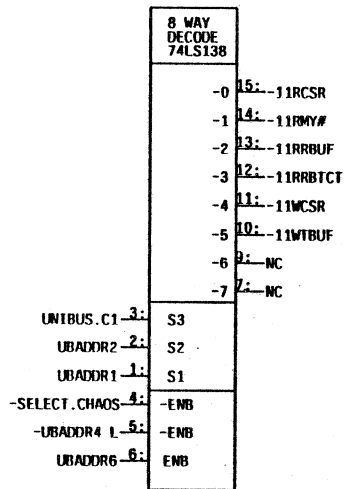

LISP Machine TV Board

\*\*\*\*\* CADRTV;LMTV4B UML  
DIP MAP \*\*\*\*\*

07-DEC-80 2352

26S10 XBDA x	74LS299 RAMSHF x	2118 RAMD x	2118 RAMC x	2118 RAMB x	2118 RAMA x
F30	E30	D30	C30	B30	A30
26S10 XBDA x	74LS374 RAMREG x	2118 RAMD x	2118 RAMC x	2118 RAMB x	2118 RAMA x
F29	E29	D29	C29	B29	A29
26S10 XBDA x	74LS299 RAMSHF x	2118 RAMD x	2118 RAMC x	2118 RAMB x	2118 RAMA x
F28	E28	D28	C28	B28	A28
26S10 XBDA x	74LS374 RAMREG x	2118 RAMD x	2118 RAMC x	2118 RAMB x	2118 RAMA x
F27	E27	D27	C27	B27	A27
26S10 XBDA x	74LS299 RAMSHF x	2118 RAMD x	2118 RAMC x	2118 RAMB x	2118 RAMA x
F26	E26	D26	C26	B26	A26
26S10 XBDA x	74LS374 RAMREG x	2118 RAMD x	2118 RAMC x	2118 RAMB x	2118 RAMA x
F25	E25	D25	C25	B25	A25
26S10 XBDA x	74LS299 RAMSHF x	2118 RAMD x	2118 RAMC x	2118 RAMB x	2118 RAMA x
F24	E24	D24	C24	B24	A24
26S10 XBDA x	74LS374 RAMREG x	2118 RAMD x	2118 RAMC x	2118 RAMB x	2118 RAMA x
F23	E23	D23	C23	B23	A23
25LS2521 XBADR x	74LS299 RAMSHF x	2118 RAMD x	2118 RAMC x	2118 RAMB x	2118 RAMA x
F22	E22	D22	C22	B22	A22
25LS2521 XBADR x	74LS374 RAMREG x	2118 RAMD x	2118 RAMC x	2118 RAMB x	2118 RAMA x
F21	E21	D21	C21	B21	A21
25LS2521 XBADR x	74LS299 RAMSHF x	2118 RAMD x	2118 RAMC x	2118 RAMB x	2118 RAMA x
F20	E20	D20	C20	B20	A20

LISP Machine TV Board \*\*\*\*\* CADRTV:LMTV4B UML 07-DEC-80 2353  
 \*\*\*\*\* DIP MAP \*\*\*\*\*

25LS2521 XBADR x	74LS374 RAMREG x	2118 RAMD x	2118 RAMC x	2118 RAMB x	2118 RAMA x
F19	E19	D19	C19	B19	A19
74LS240 XBADR x	74LS299 RAMSHF x	2118 RAMD x	2118 RAMC x	2118 RAMB x	2118 RAMA x
F18	E18	D18	C18	B18	A18
74LS240 XBADR x	74LS374 RAMREG x	2118 RAMD x	2118 RAMC x	2118 RAMB x	2118 RAMA x
F17	E17	D17	C17	B17	A17
74LS240 XBADR x	74LS299 RAMSHF x	2118 RAMD x	2118 RAMC x	2118 RAMB x	2118 RAMA x
F16	E16	D16	C16	B16	A16
26S10 XBADATA x	74LS374 RAMREG x	2118 RAMD x	2118 RAMC x	2118 RAMB x	2118 RAMA x
F15	E15	D15	C15	B15	A15
26S10 XBADATA x	74LS74 XBCTL xx	898-3-R2 RAMBUF x	898-3-R2 RAMBUF x	898-3-R2 RAMBUF x	898-3-R2 RAMBUF x
F14	E14	D14	C14	B14	A14
74S138 XBCTL x	74S00 XBCTL xxxx	74LS244 COLOR x	74S37 RAMCAS xxxx	898-3-R2 RAMCAS x	74S241 RAMBUF x
F13	E13	D13	C13	B13	A13
25LS2519 XBCTL x	74S374 XBCTL x	74S00 SYNCLK xxxx	25LS2539 RAMCAS xx	74S253 RAMADR x	74S253 RAMADR x
F12	E12	D12	C12	B12	A12
74LS244 COLOR x	74S32 COLOR xxxo	TD100 RAMCAS x	74S37 SYNCLK xxxx	74S253 RAMADR x	74S253 RAMADR x
F11	E11	D11	C11	B11	A11
74S04 XBADATA xxxxxx	74S139 XBCTL xx	74S08 SYNCLK xxxx	74LS163 TVMA x	74LS569 RAMADR x	74LS569 RAMADR x
F10	E10	D10	C10	B10	A10
74S257 COLOR x	74S241 COLOR x	74S37 SYNCLK xxxx	74LS163 TVMA x	74LS163 TVMA x	74LS163 TVMA x
F09	E09	D09	C09	B09	A09

LISP Machine TV Board

\*\*\*\*\* CADRTV:LMTV4B UML  
DIP MAP \*\*\*\*\*

07-DEC-80 2353

10105 ECLCLK oox	74128 ECLVID xx00	74S04 RAMADR xxxxxx	EXAR-CL ECLCLK x	74S283 TVINC x	74S283 TVINC x
F08	E08	D08	C08	B08	A08
10124 ECLCLK x	10124 ECLVID x	74S374 SYNCLK x	74LS377 SYNADR x	74LS377 SYNADR x	74LS273 TVINC x
F07	E07	D07	C07	B07	A07
10124 ECLVID x	10124 ECLVID x	74S288 SYNCLK x	74LS569 SYNADR x	74LS569 SYNADR x	74LS569 SYNADR x
F06	E06	D06	C06	B06	A06
DUAL-SIP ECLSIP x	DUAL-SIP ECLSIP x	74LS244 SYNRAM x	74S472 SYNRAM x	74LS374 SYNADR x	74LS374 SYNADR x
F05	E05	D05	C05	B05	A05
10102 ECLVID xxxx	10141 ECLVID x	74S51 TVMA xx	25LS2539 SYNREG xx	2147 SYNRAM x	2147 SYNRAM x
F04	E04	D04	C04	B04	A04
10212 ECLVID x0	10141 ECLVID x	74S04 TVMA xxxxxx	74S374 SYNREG x	2147 SYNRAM x	2147 SYNRAM x
F03	E03	D03	C03	B03	A03
10136 ECLCLK x	10125 ECLCLK x	74LS175 SYNREG x	74LS669 SYNREG x	2147 SYNRAM x	2147 SYNRAM x
F02	E02	D02	C02	B02	A02
10121 ECLVID x	DUAL-SIP ECLSIP x	74S10 SYNREG xxx	74LS669 SYNREG x	2147 SYNRAM x	2147 SYNRAM x
F01	E01	D01	C01	B01	A01

LISP Machine TV Board CADRTV;LMTV4B UML 07-DEC-80 2353 \*\*\*\*\* EDGE CONNECTIONS Flags: (# Output, @ Terminator, ---- Dedicated ground, ++++ Dedicated power) \*\*\*\*\*

Table with 4 columns labeled -A-, -B-, -C-, and -D-. It lists various bus connections such as A1 -XBUS35, B1 -XBUS34, C1 -XBUS33, D1 -XBUS32, E1 -XBUS30, F1 DEVRDR 17, H1 -XBUS27, J1 -XBUS25, K1 -XBUS23, L1 -XBUS21, M1 -XBUS19, N1 DEVRDR 17, P1 -XBUS16, R1 -XBUS14, S1 -XBUS12, T1 DEVRDR 17, U1 -XBUS9, V1 -XBUS7, and V2 -XBUS6. Each entry includes a pin number and a signal name, with some including direction indicators like 'H' for high or 'H #' for high with a pull-up resistor.

LISP Machine TV Board CADRTV:LMTV4B UML 07-DEC-80 2353  
 \*\*\*\*\* EDGE CONNECTIONS Flags: (# Output, @ Terminator, ---- Dedicated ground, ++++ Dedicated power) \*\*\*\*\*  
 -E- -F- -J01- -J02-

A1	A1	01	01
A2 +5.0V+++++	A2 +5.0V+++++	02	02
B1	B1	03	03
B2	B2	04	04
C1	C1	05	05
C2 DEVADR 17-----	C2 DEVADR 17-----	06	06
D1	D1 COMP VIDEO OUT	07	07
D2	D2	08	08
E1	E1 -BLANKING (FUDGED) H #	09	09
E2	E2 TTL VIDEO DRIVE #	10	10
F1 DEVADR 17	F1 DEVADR 17	11	11
F2	F2	12	12
H1 COLOR VALUE 0	#H1 MECL VIDEO OUT	#13	13
H2	H2	14	14
J1 COLOR VALUE 1	#J1 -MECL VIDEO OUT H	#15	15
J2	J2	16	16
K1 COLOR VALUE 2	#K1 COLOR 0	#17	17
K2	K2	18	18
L1 COLOR VALUE 3	#L1 COLOR 1	#19	19
L2	L2	20	20
M1 COLOR VALUE 4	#M1 COLOR 2	#21	21
M2	M2	22	22
N1 DEVADR 17	N1 DEVADR 17	23	23
N2	N2	24	24
P1 COLOR VALUE 5	#P1 COLOR 3	#25	25
P2	P2	26	26
R1 COLOR VALUE 6	#R1 COLOR 4	#27	27
R2	R2	28	28
S1 COLOR VALUE 7	#S1 COLOR 5	#29	29
S2	S2	30	30
T1 DEVADR 17-----	T1 DEVADR 17-----	31	31
T2	T2	32	32
U1 HSYNC OUT	#U1 COLOR 6	#33	33
U2	U2	34	34
V1 VSYNC OUT	#V1 COLOR 7	#35	35
V2	V2	36	36
		37	37
		38	38
		39	39
		40	40
		41	41
		42	42
		43	43
		44	44
		45	45
		46	46
		47	47
		48	48
		49	49
		50	50

LISP Machine TV Board

CADRTV:LMTV4B UML

07-DEC-80 2354

\*\*\*\*\* EDGE CONNECTIONS Flags: (# Output, @ Terminator, ---- Dedicated ground, ++++ Dedicated power) \*\*\*\*\*

-J03-		-J04-		-J05-		-J06-	
01		01		01		01	
02		02		02		02	
03		03		03		03	
04		04		04		04	
05		05		05		05	
06		06		06		06	
07		07		07		07	
08		08		08		08	
09		09		09		09	
10		10		10		10	
11		11		11		11	
12		12		12		12	
13		13		13		13	
14		14		14		14	
15		15		15		15	
16		16		16		16	
17		17		17		17	
18		18		18		18	
19		19		19		19	
20		20		20		20	
21	-----	21	-----	21	-----	21	-----
22	-----	22	-----	22	-----	22	-----
23	-----	23	-----	23	-----	23	-----
24	-----	24	-----	24	-----	24	-----
25	-----	25	-----	25	-----	25	-----
26	-----	26	-----	26	-----	26	-----
27	-----	27	-----	27	-----	27	-----
28	-----	28	-----	28	-----	28	-----
29	-----	29	-----	29	-----	29	-----
30	-----	30	-----	30	-----	30	-----
31	-----	31	-----	31	-----	31	-----
32	-----	32	-----	32	-----	32	-----
33	-----	33	-----	33	-----	33	-----
34	-----	34	-----	34	-----	34	-----
35	-----	35	-----	35	-----	35	-----
36	-----	36	-----	36	-----	36	-----
37	-----	37	-----	37	-----	37	-----
38	-----	38	-----	38	-----	38	-----
39	-----	39	-----	39	-----	39	-----
40	-----	40	-----	40	-----	40	-----
				41	-----	41	-----
				42	-----	42	-----
				43	-----	43	-----
				44	-----	44	-----
				45	-----	45	-----
				46	-----	46	-----
				47	-----	47	-----
				48	-----	48	-----
				49	-----	49	-----
				50	-----	50	-----

LISP Machine TV Board CADRTV:LMTV4B UML 07-DEC-80 2354  
\*\*\*\*\* EDGE CONNECTIONS Flags: (# Output, @ Terminator, ---- Dedicated ground, ++++ Dedicated power) \*\*\*\*\*

-J07-		-J08-		-J09-		-J10-	
01		01		01		01	
02		02		02		02	
03		03		03		03	
04		04		04		04	
05		05		05		05	
06		06		06		06	
07		07		07		07	
08		08		08		08	
09		09		09		09	
10		10		10		10	
11		11		11		11	
12		12		12		12	
13		13		13		13	
14		14		14		14	
15		15		15		15	
16		16		16		16	
17		17		17		17	
18		18		18		18	
19		19		19		19	
20		20		20		20	
21	-----	21	-----	21	-----	21	-----
22	-----	22	-----	22	-----	22	-----
23	-----	23	-----	23	-----	23	-----
24	-----	24	-----	24	-----	24	-----
25	-----	25	-----	25	-----	25	-----
26	-----	26	-----	26	-----	26	-----
27	-----	27	-----	27	-----	27	-----
28	-----	28	-----	28	-----	28	-----
29	-----	29	-----	29	-----	29	-----
30	-----	30	-----	30	-----	30	-----
31	-----	31	-----	31	-----	31	-----
32	-----	32	-----	32	-----	32	-----
33	-----	33	-----	33	-----	33	-----
34	-----	34	-----	34	-----	34	-----
35	-----	35	-----	35	-----	35	-----
36	-----	36	-----	36	-----	36	-----
37	-----	37	-----	37	-----	37	-----
38	-----	38	-----	38	-----	38	-----
39	-----	39	-----	39	-----	39	-----
40	-----	40	-----	40	-----	40	-----
				41	-----	41	-----
				42	-----	42	-----
				43	-----	43	-----
				44	-----	44	-----
				45	-----	45	-----
				46	-----	46	-----
				47	-----	47	-----
				48	-----	48	-----
				49	-----	49	-----
				50	-----	50	-----





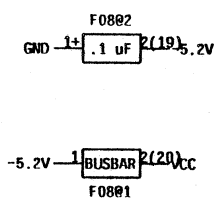
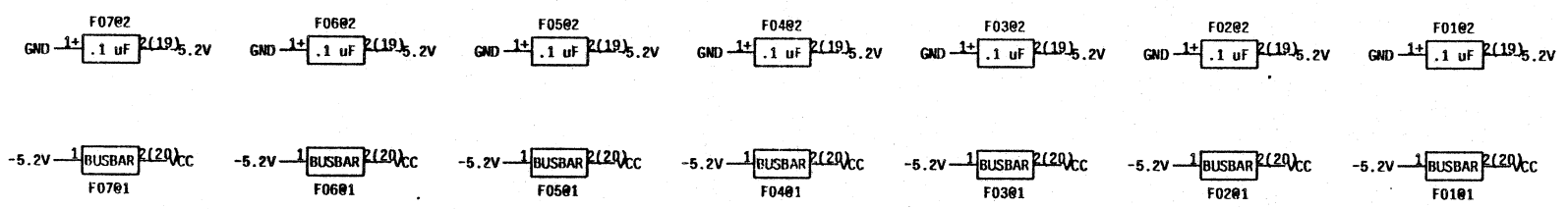
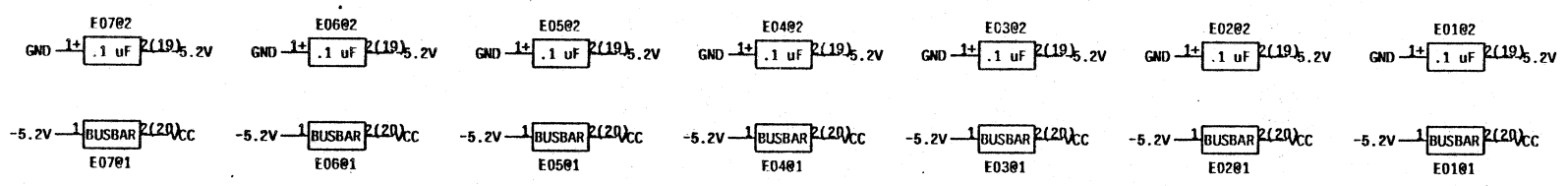
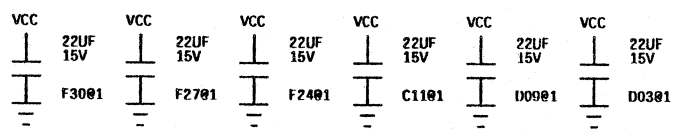

SHOULD BE USING  
GROUND CLIPS ON PIN 2

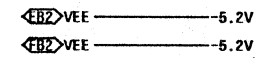

USE .1uF DIP CAPS NEXT TO EVERY OTHER MEMORY CHIP

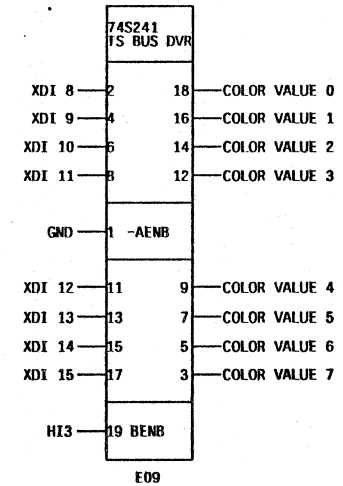
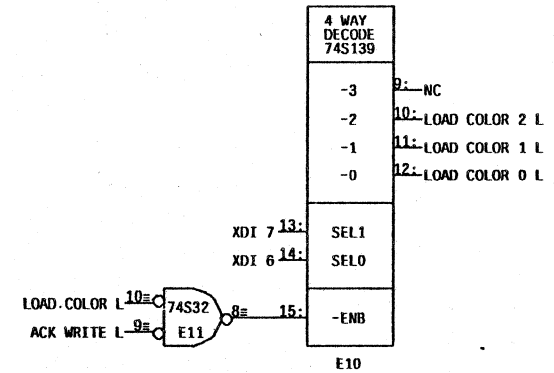
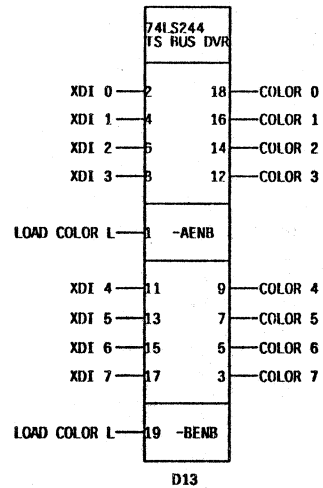
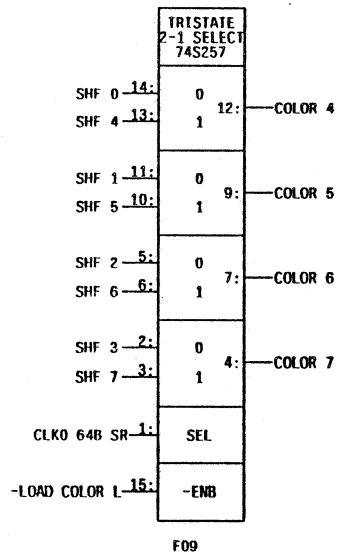
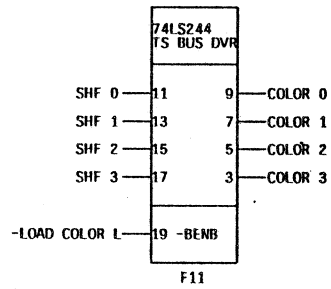

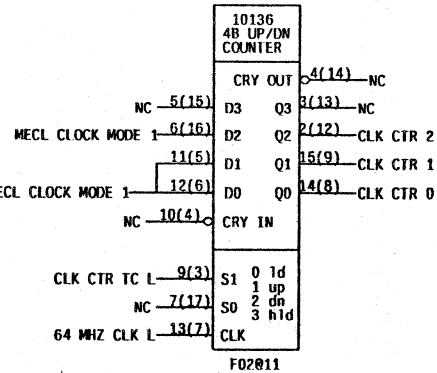
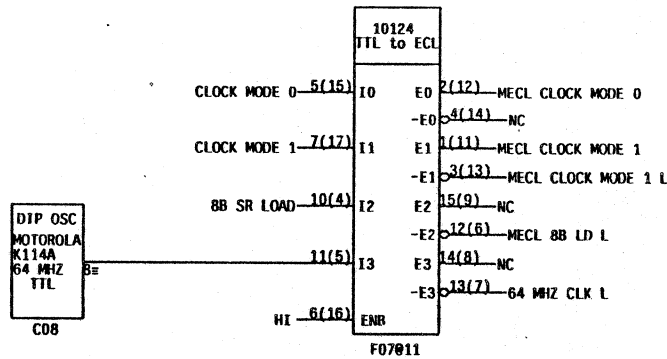
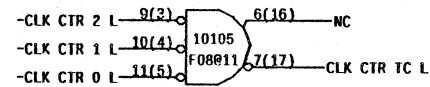
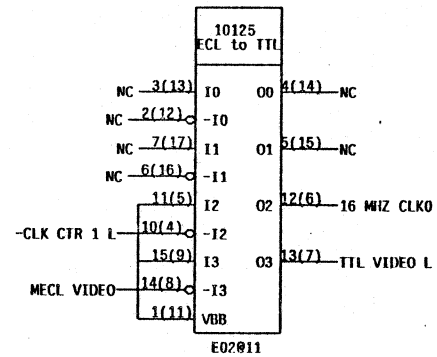
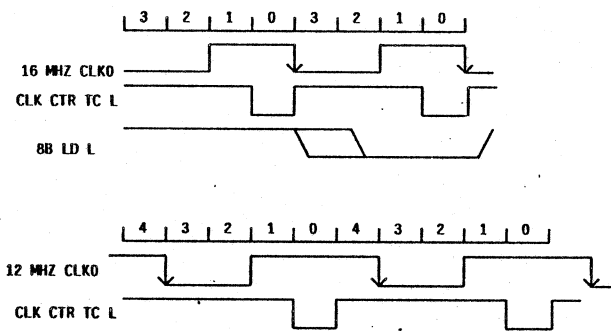

NOTE: Install with pin 1 down

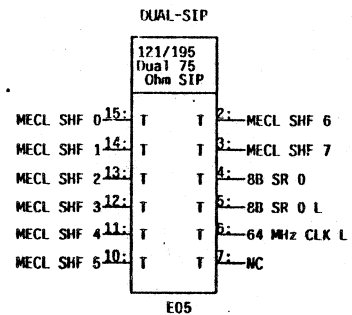

NOTE: Install with pin 1 down

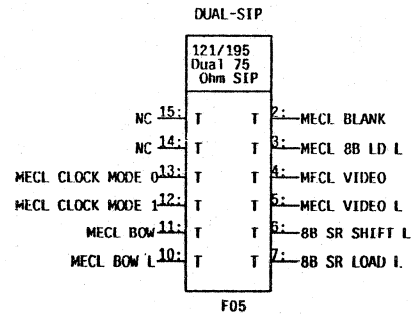

NOTE: Install with pin 1 down

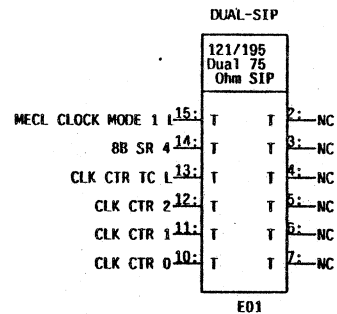

INSTALL 121 OHM SIDE OF SIP CONNECTED TO PIN 10

THE "NC" SIP PINS SHOULD MEASURE -2 VOLTS

CLOCK MODE

10 MHZ. MODE  
 ---  
 00 64 CPT  
 01 32 M4408  
 (OR 16 MHZ COLOR)  
 10 12 525 LINE  
 11 12 COLOR

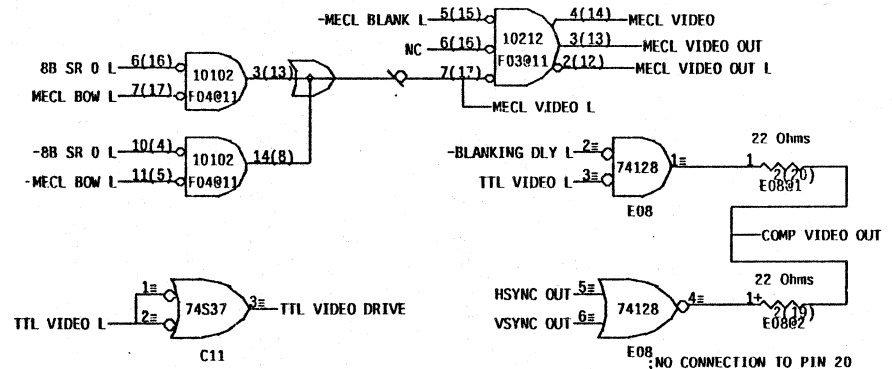
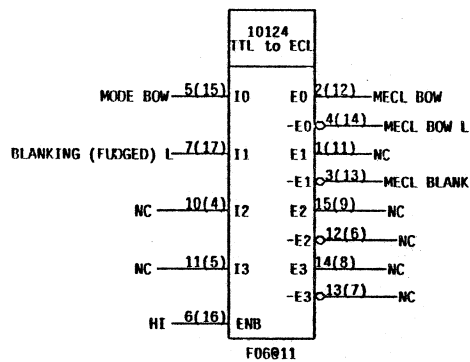
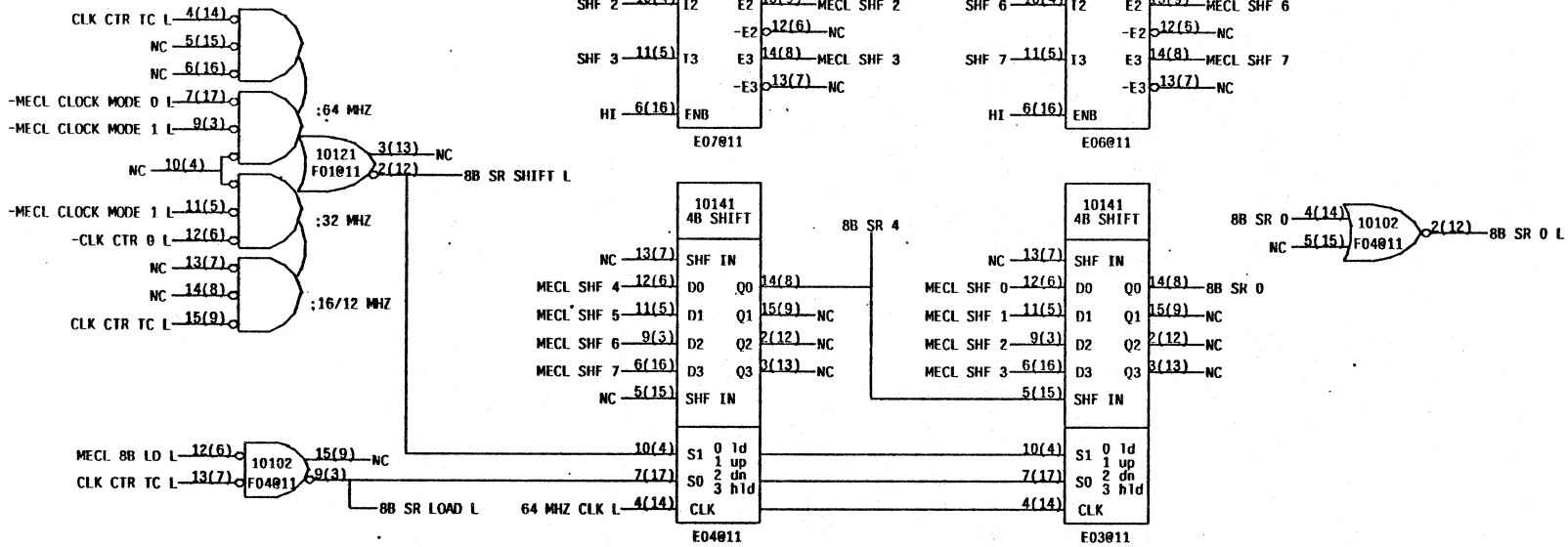

GND — SHF IN 0  
GND — SHF IN 1  
GND — SHF IN 2  
GND — SHF IN 3  
GND — SHF IN 4  
GND — SHF IN 5  
GND — SHF IN 6  
GND — SHF IN 7

MAPADR 15 — MAPADR BANK  
ADR 15 — ADR BANK SEL  
ADR 14 — RAM ADR IN 13  
ADR 13 — RAM ADR IN 12  
ADR 12 — RAM ADR IN 11  
ADR 11 — RAM ADR IN 10  
ADR 10 — RAM ADR IN 9  
ADR 9 — RAM ADR IN 8  
ADR 8 — RAM ADR IN 7  
ADR 7 — RAM ADR IN 6  
ADR 6 — RAM ADR IN 5  
ADR 5 — RAM ADR IN 4  
ADR 4 — RAM ADR IN 3  
ADR 3 — RAM ADR IN 2  
ADR 2 — RAM ADR IN 1  
ADR 1 — RAM ADR IN 0

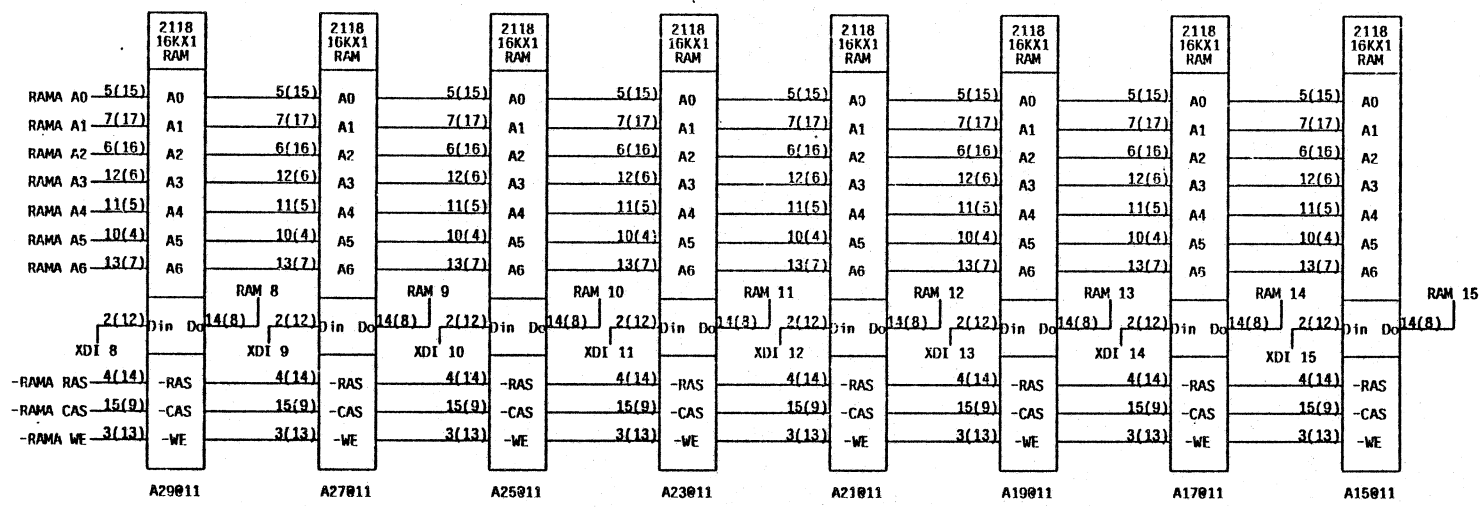
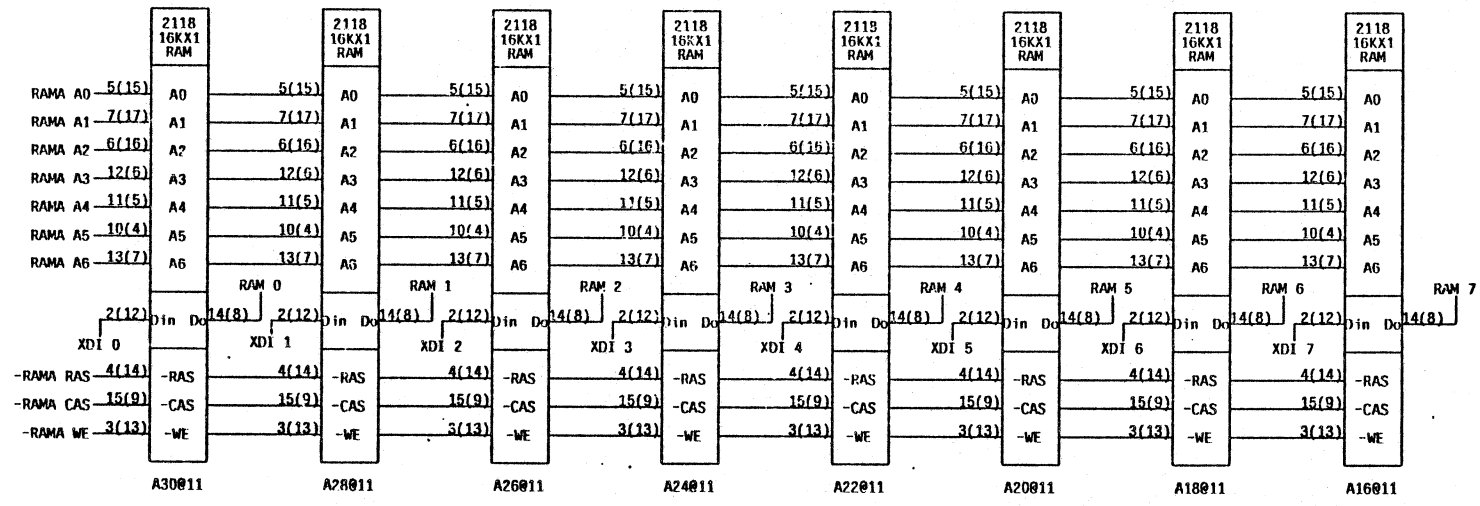



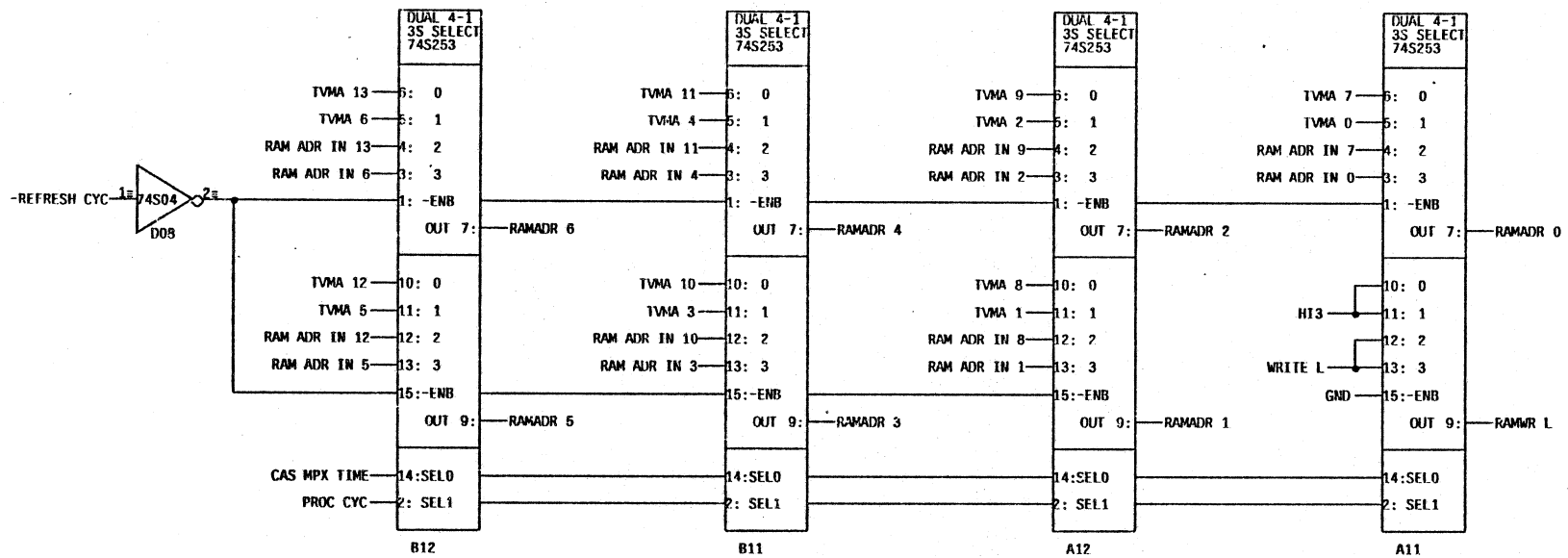
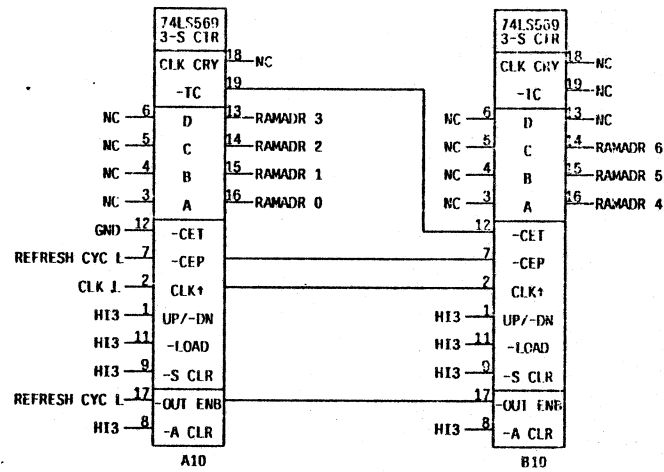

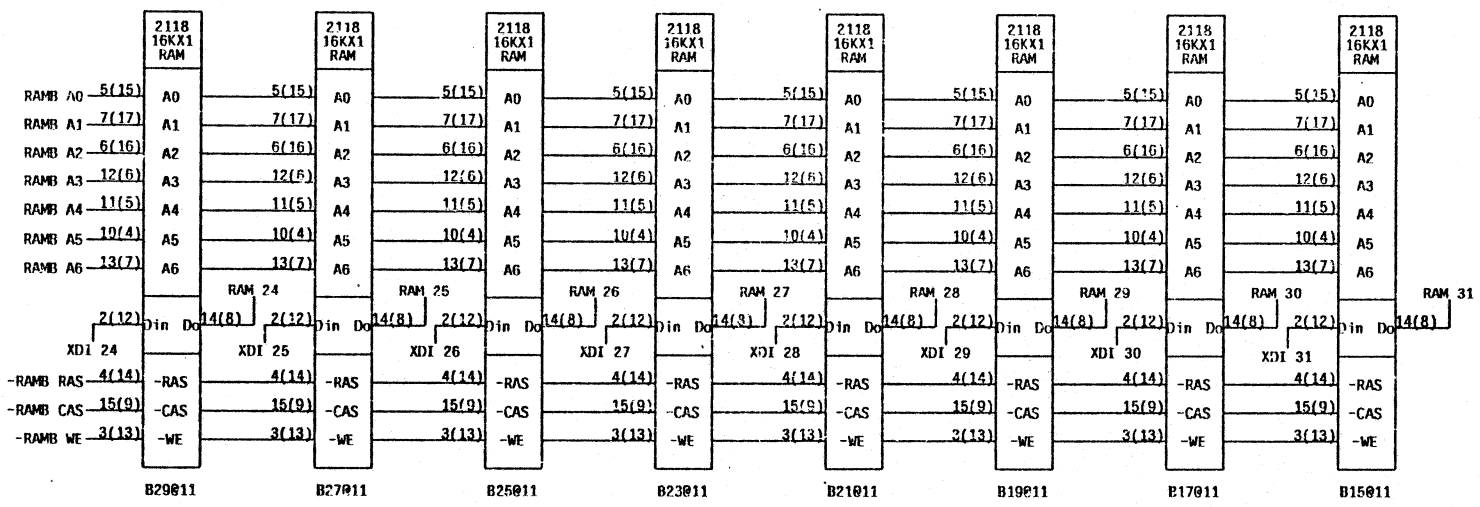
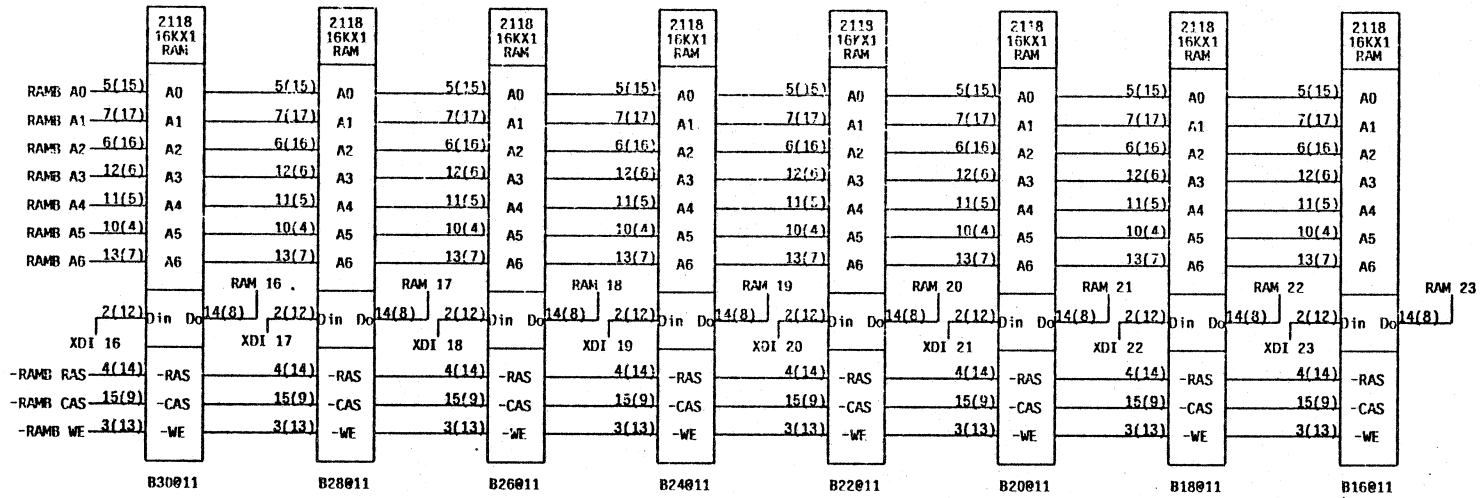

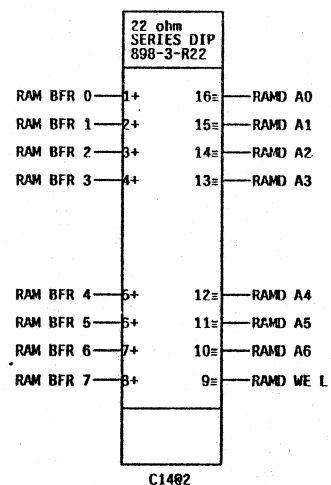
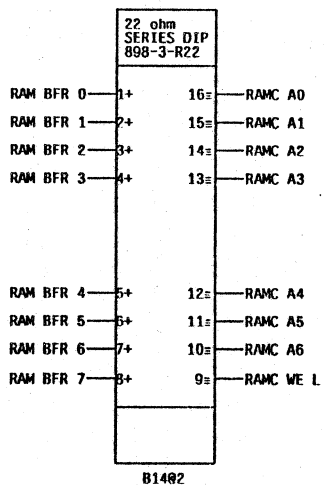
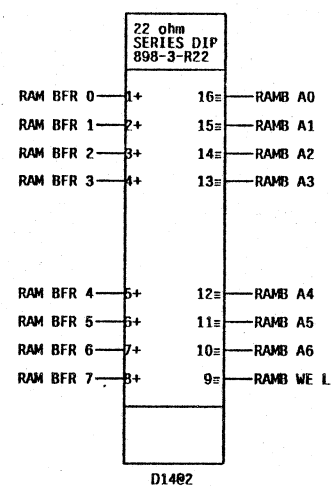
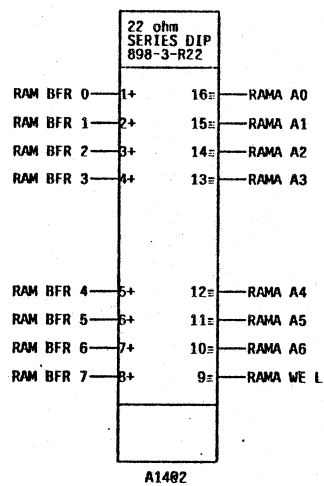
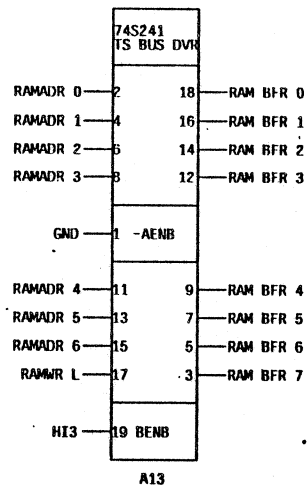

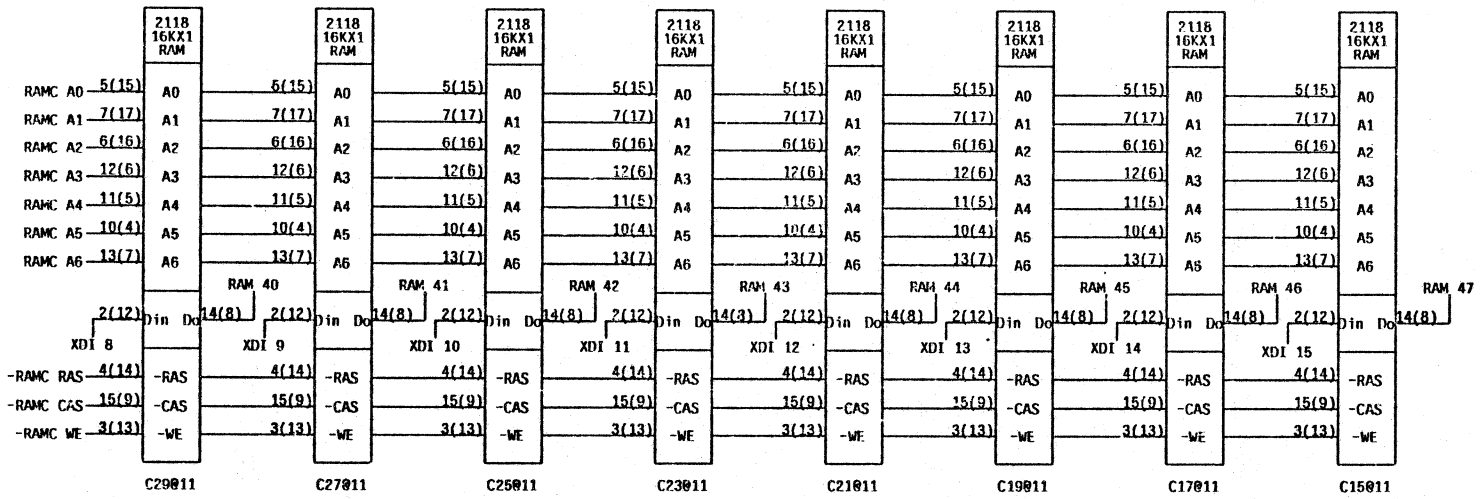
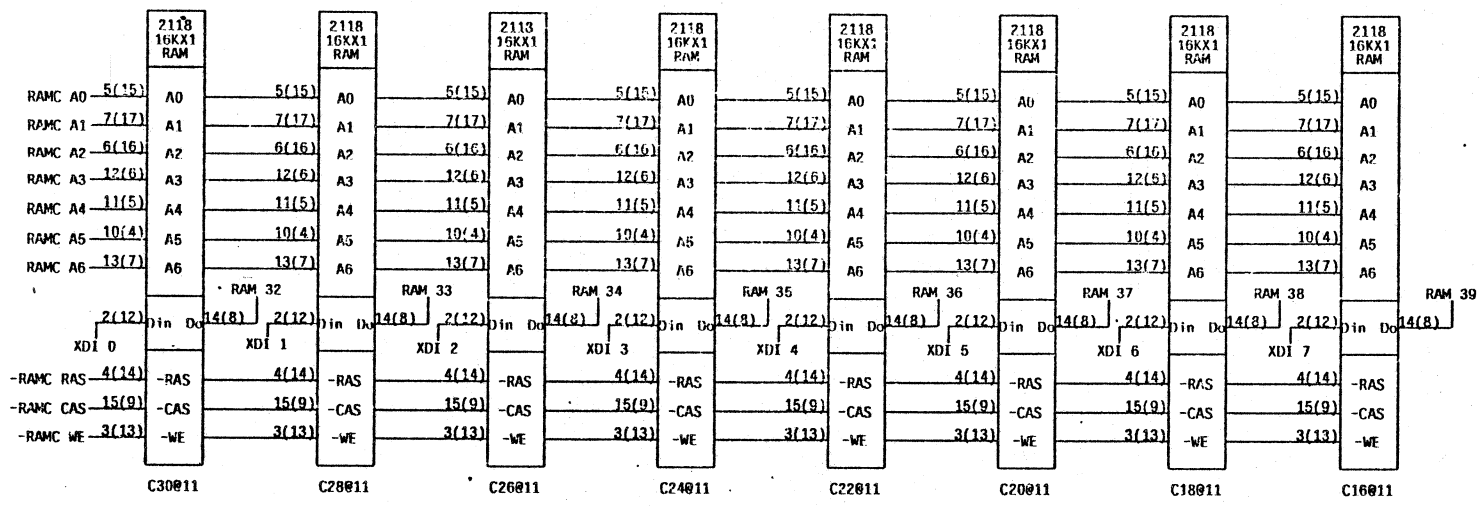

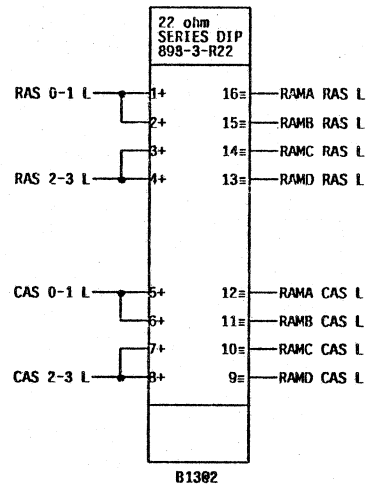
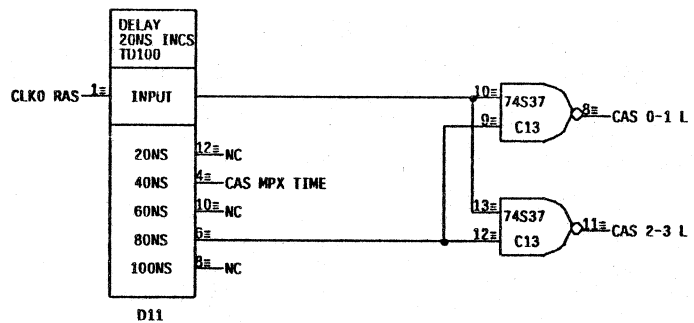
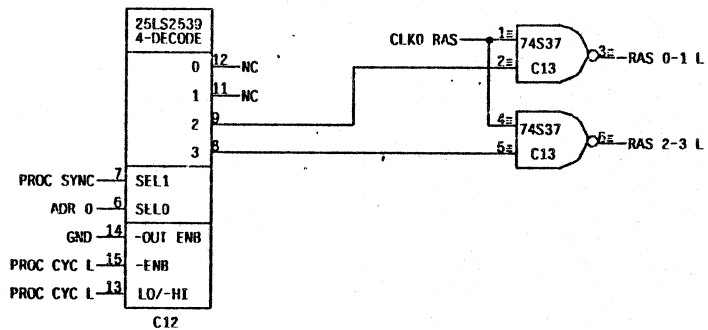
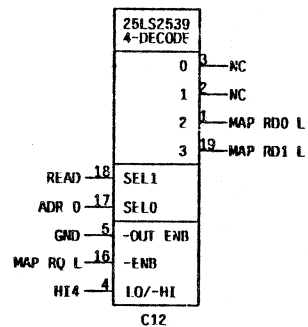



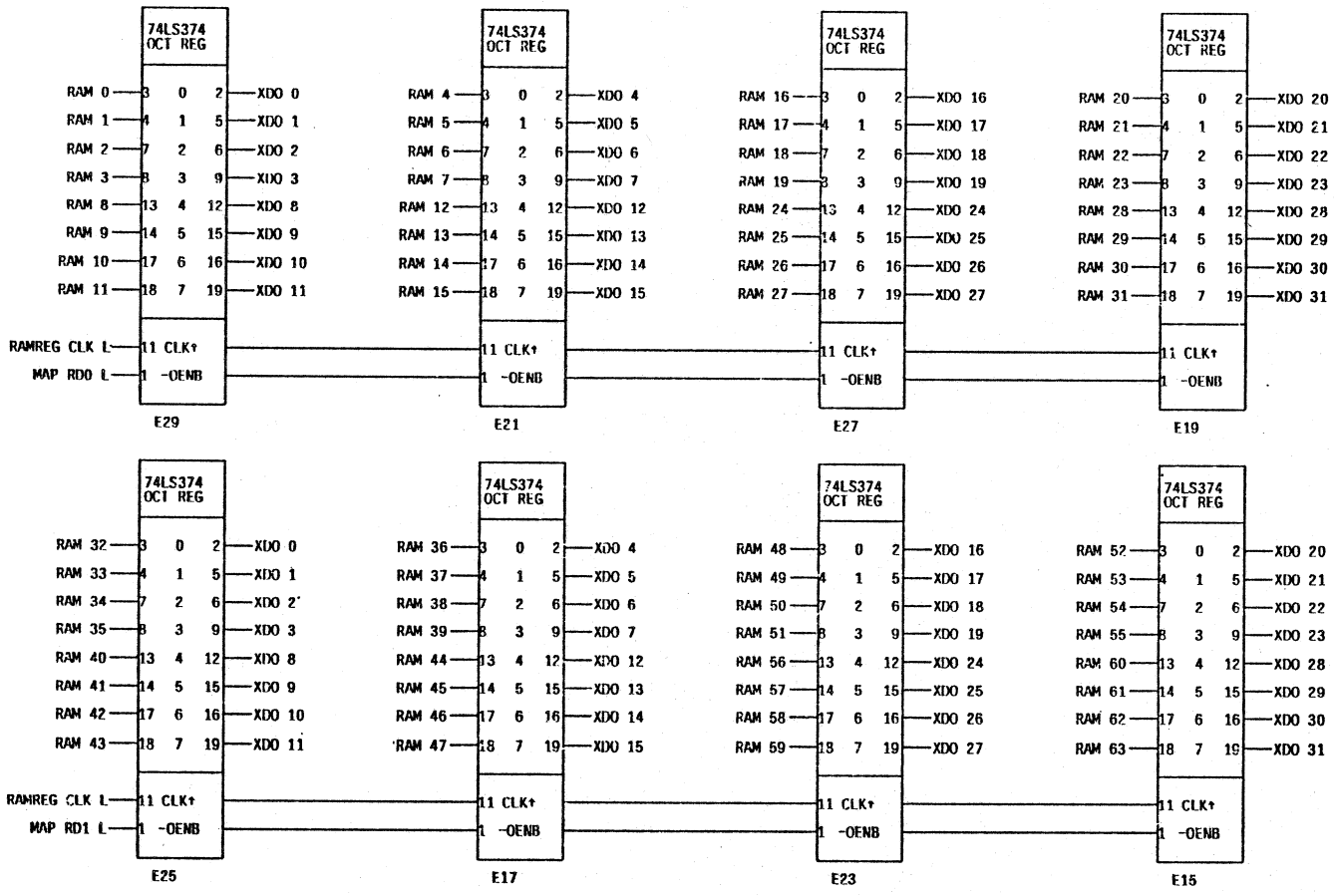

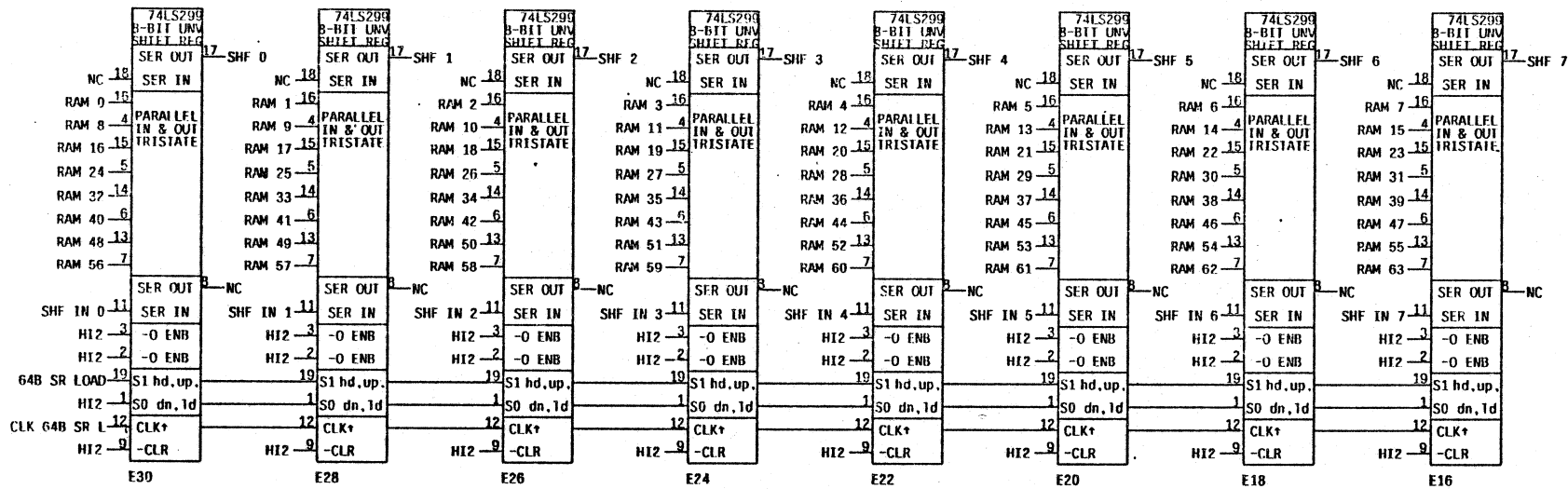



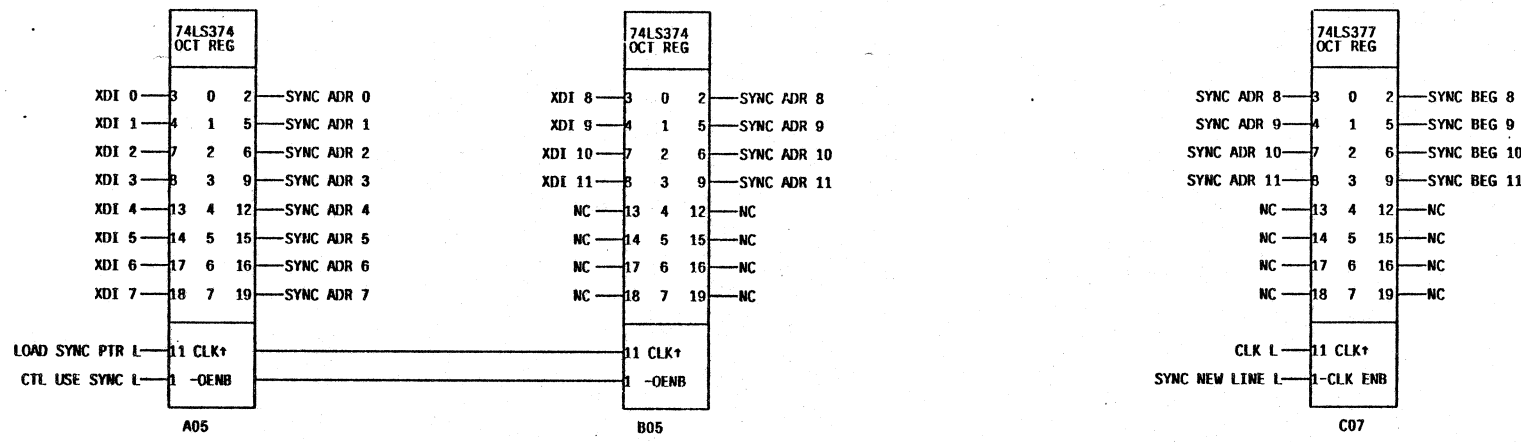
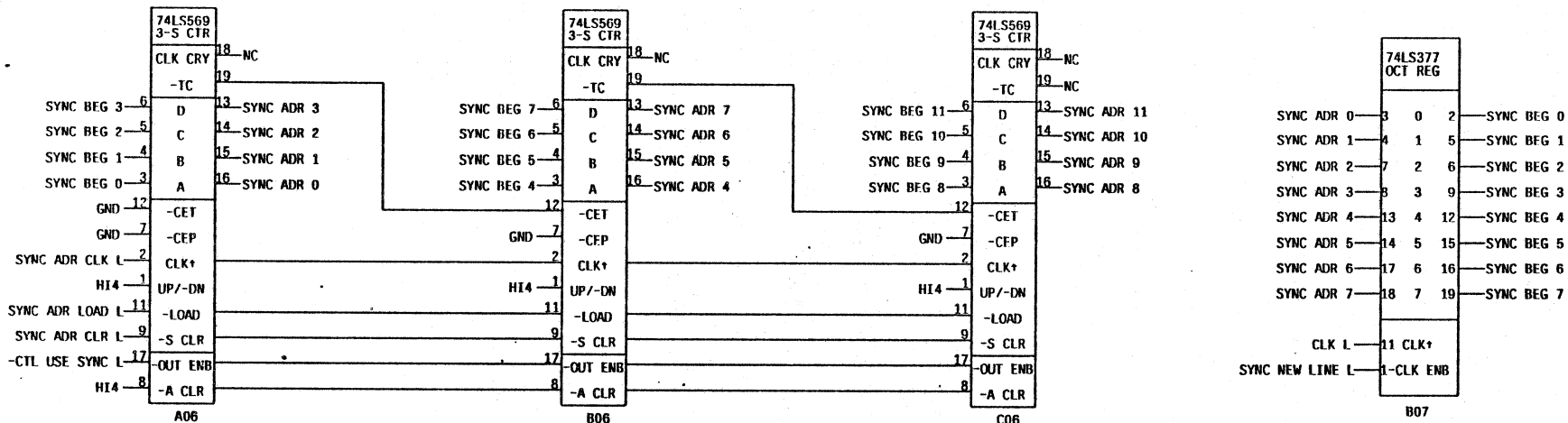

ON CADRTV: NXBCTL

SYNC PROM

4 CLK0  
5 CLK0 65B SR  
7 CLK0 RAS

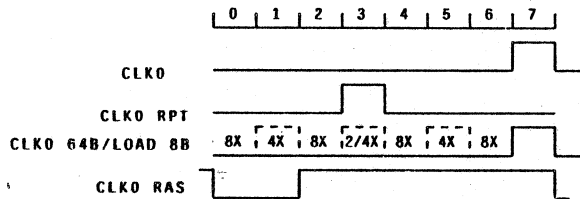
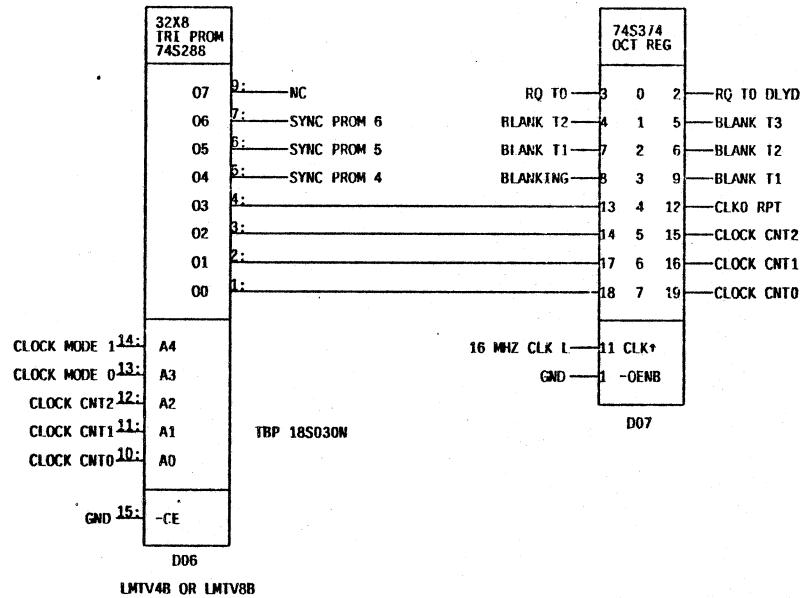

CLOCK MODE

10 MHZ, MODE

00 64 CPT  
01 32 M4408  
(OR 16 MHZ COLOR)  
10 12 525 LINE  
11 12 COLOR

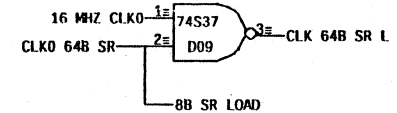
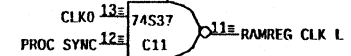
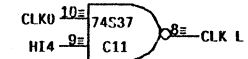
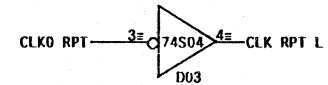
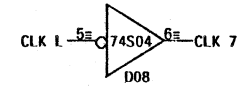
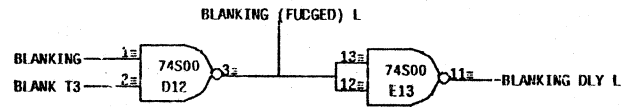

CLK 7 DELAYED FROM CLK0  
ALLOW FOR HOLD TIME OF 74S299

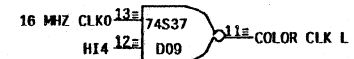
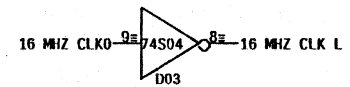
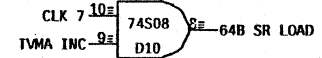

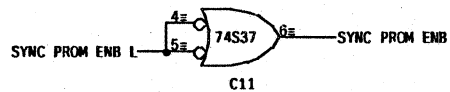
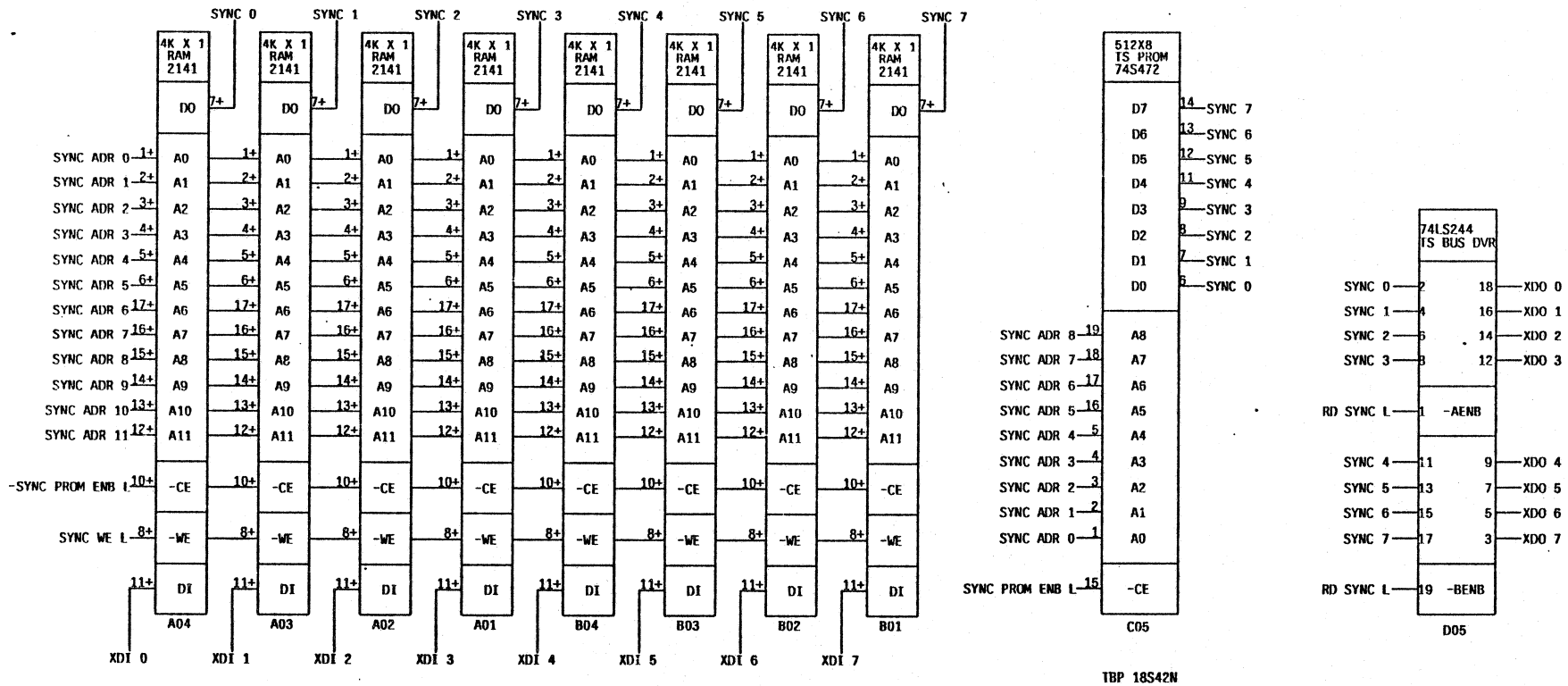

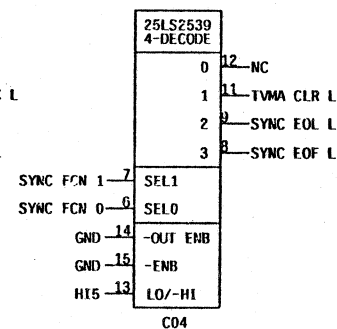
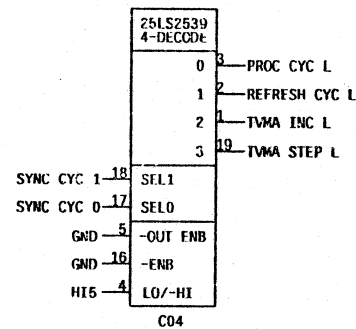
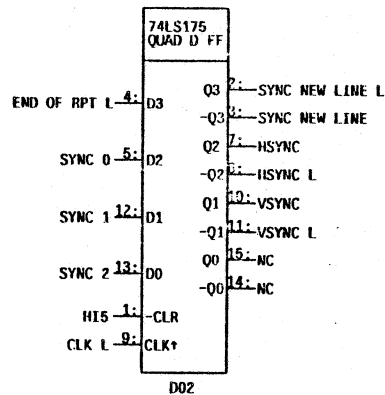
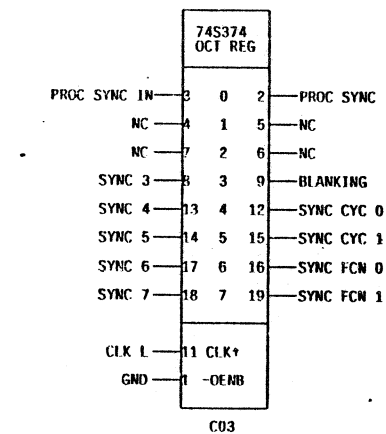

SYNC CYC 1 — TVMA INC & STEP      SYNC FCN 1 — SYNC EOL & EOF

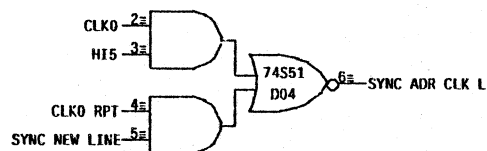
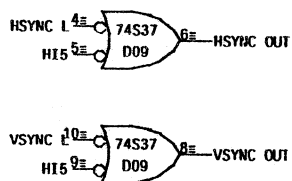
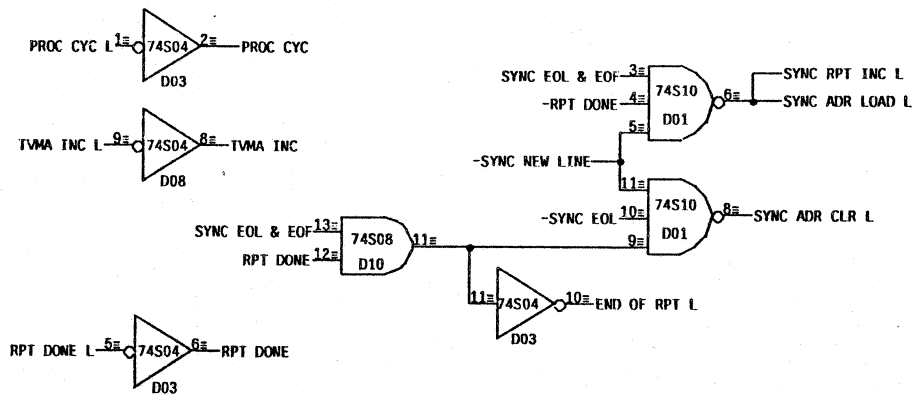
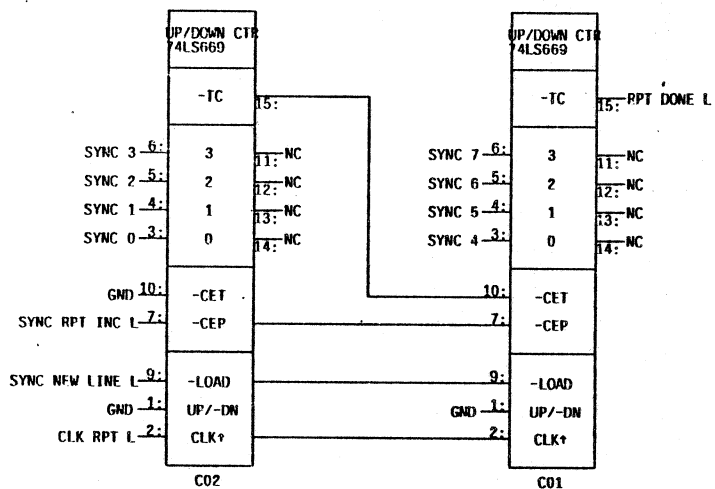

SYNC PROGRAM

- 0 HORIZONTAL SYNC
- 1 VERTICAL SYNC
- 2 --
- 3 BLANKING
- 4,5 0 PROCESSOR CYCLE
- 1 REFRESH
- 2 DISPLAY
- 3 NEW LINE
- 0 --
- 6,7 1 START OF FRAME
- 2 END OF LINE
- 3 END OF FRAME

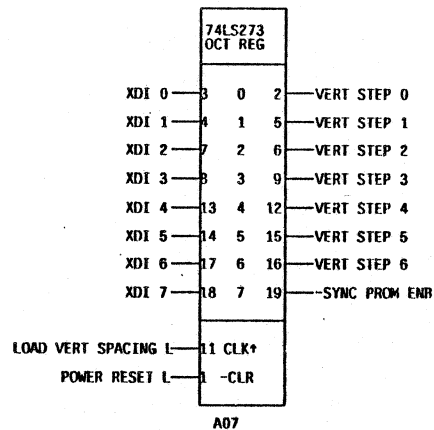
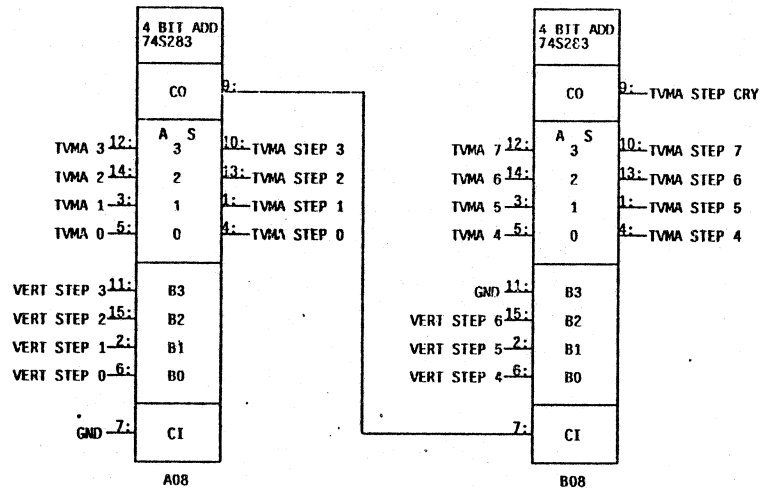

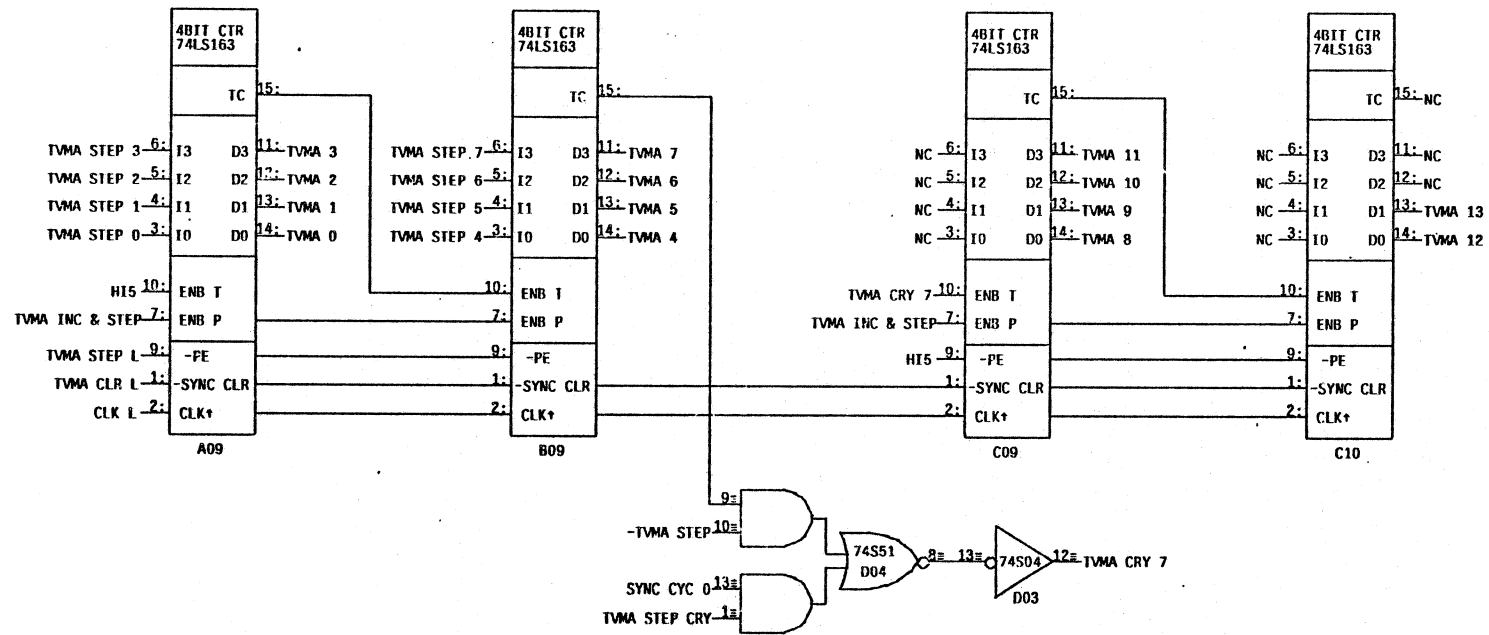

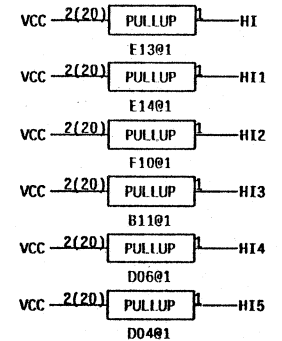
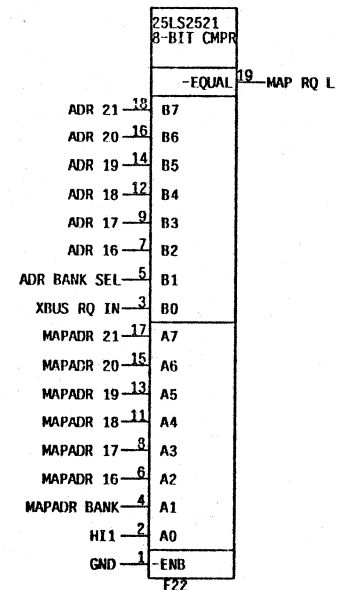
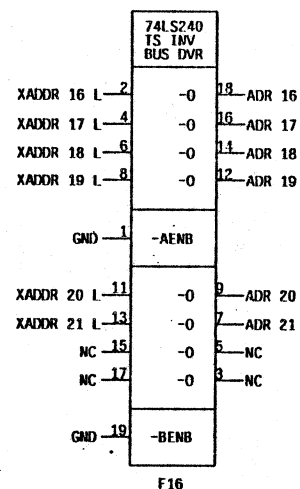
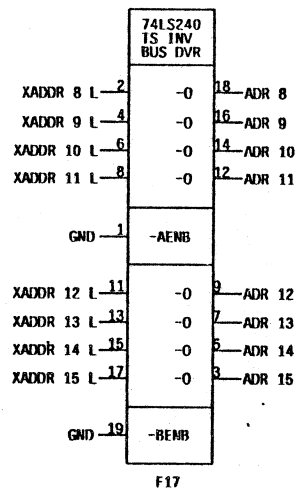
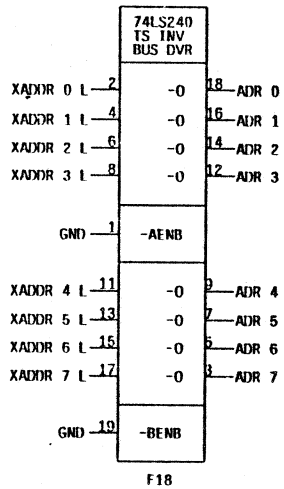

17 000 000 to  
17 077 777

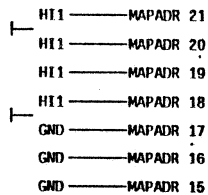

CONTROL ADDRESS  
17 377 760

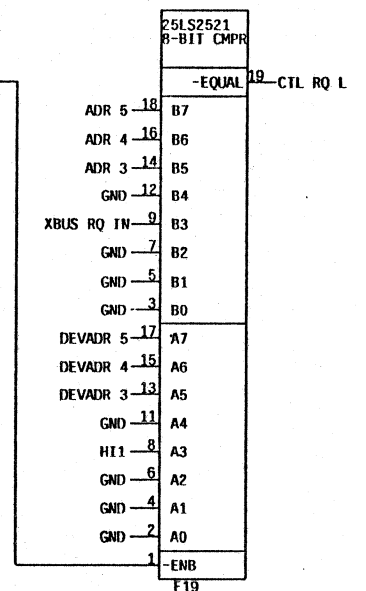
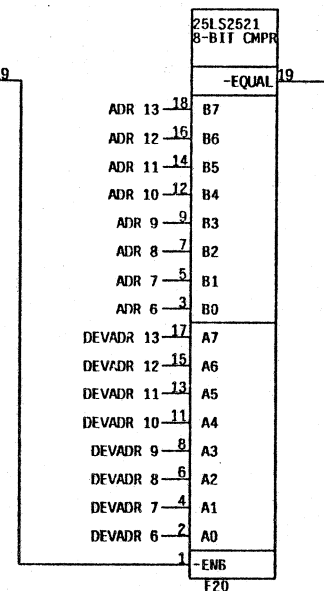
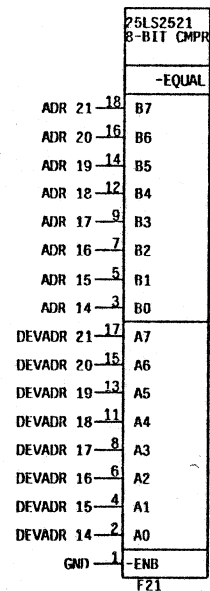
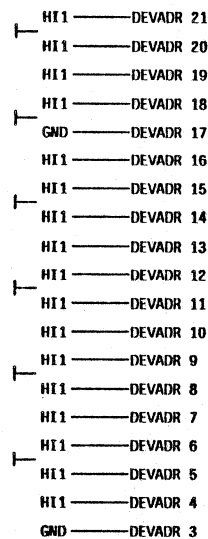

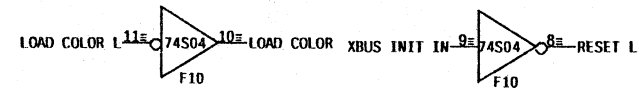
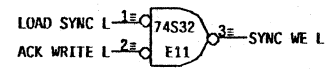
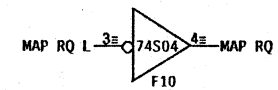
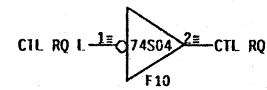
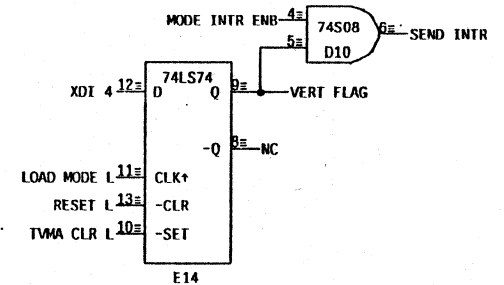
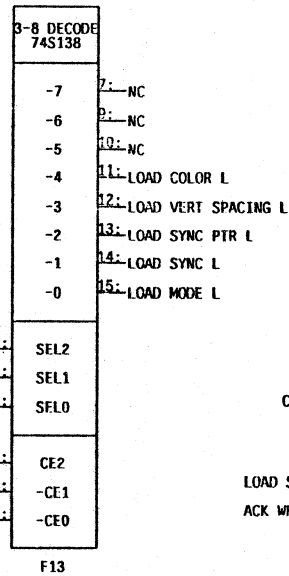
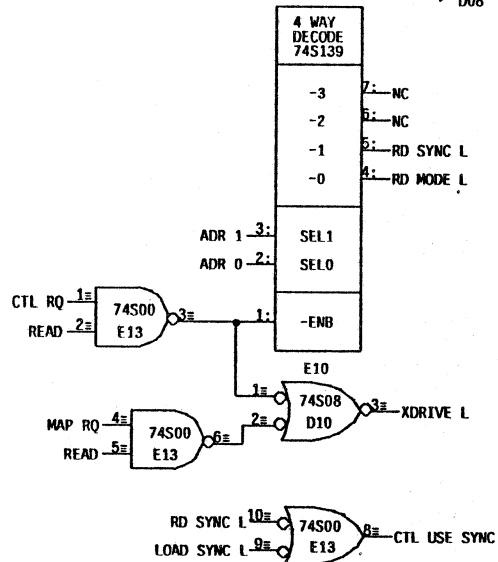
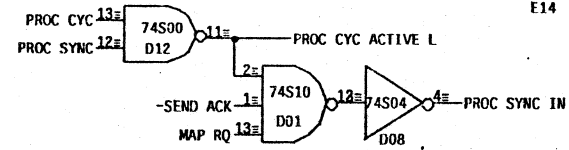
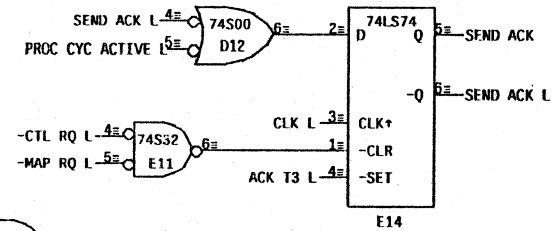
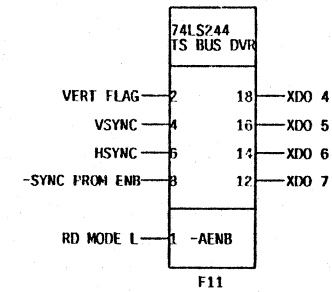
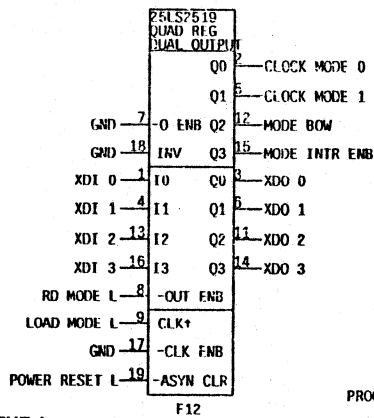
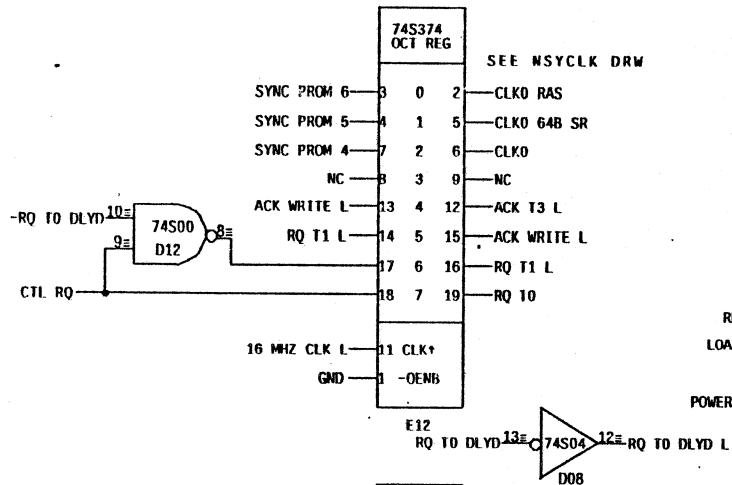



WRITE L READ

WRITE READ L

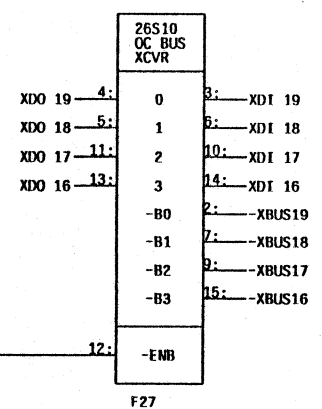
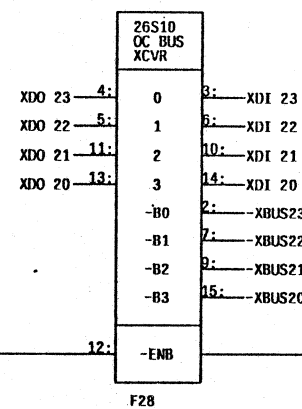
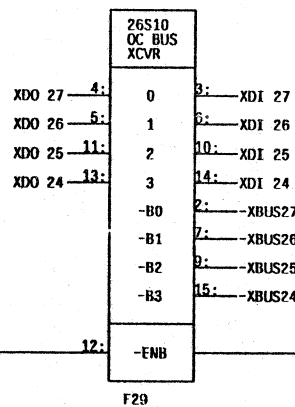
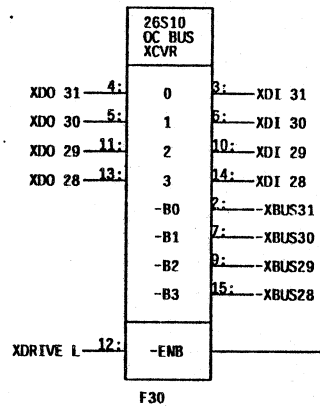
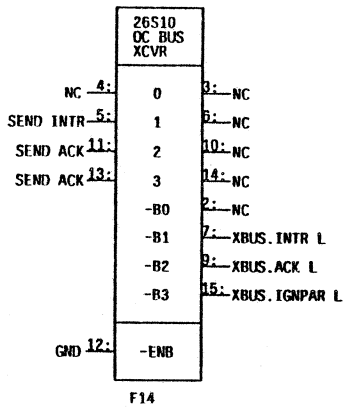
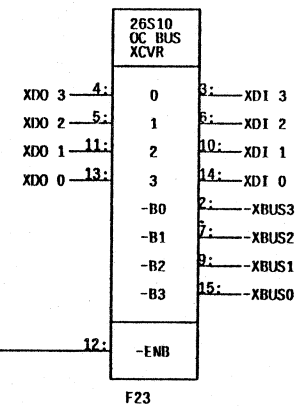
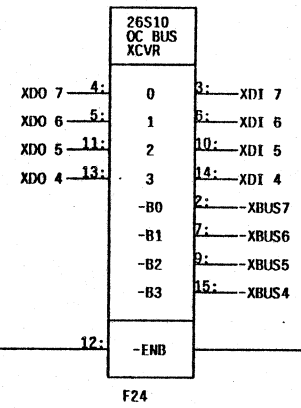
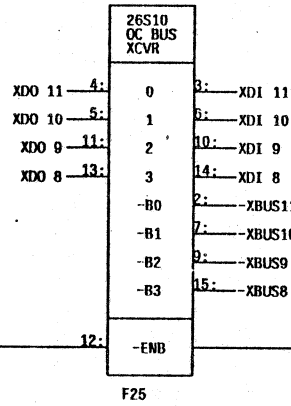
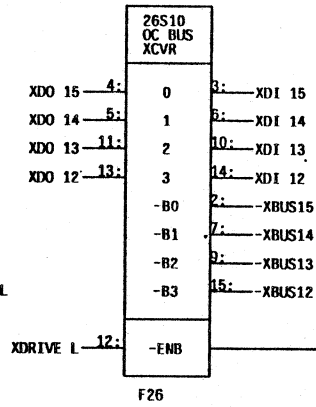
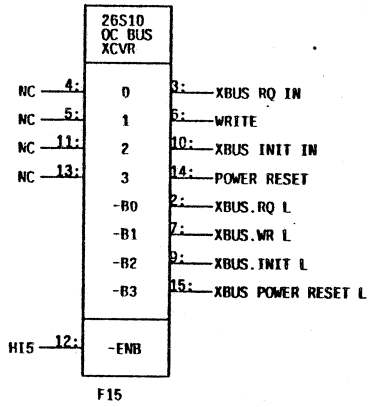
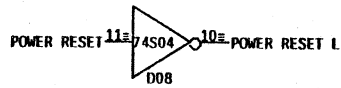
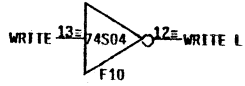



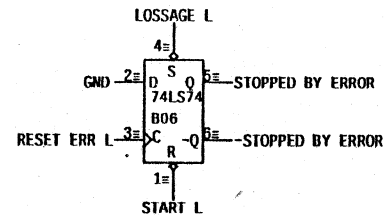
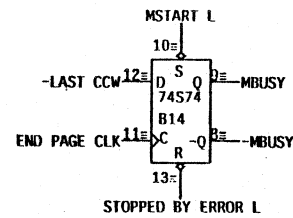
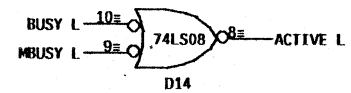
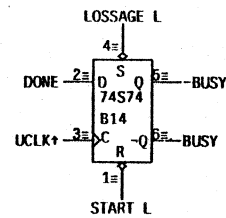
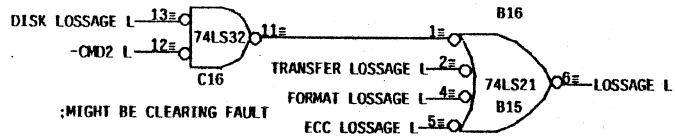
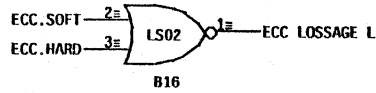
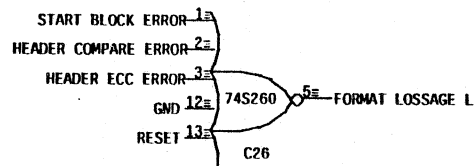
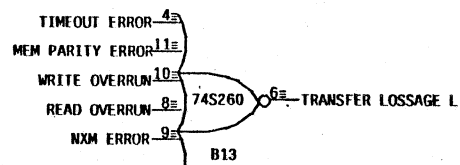
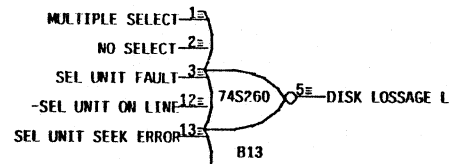

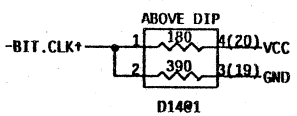
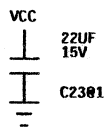
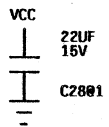
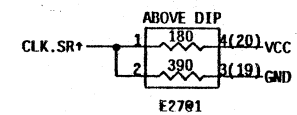
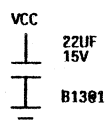
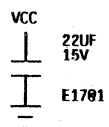
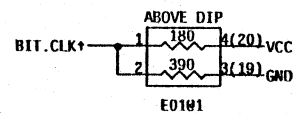
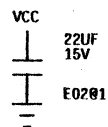
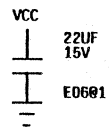

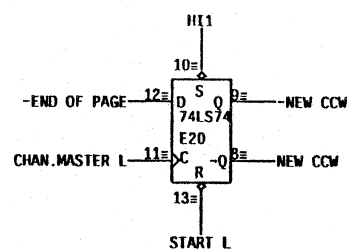
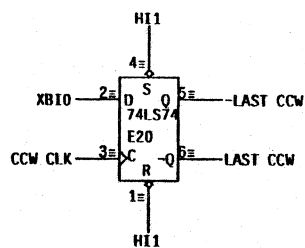
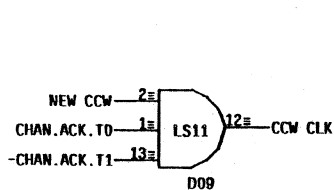
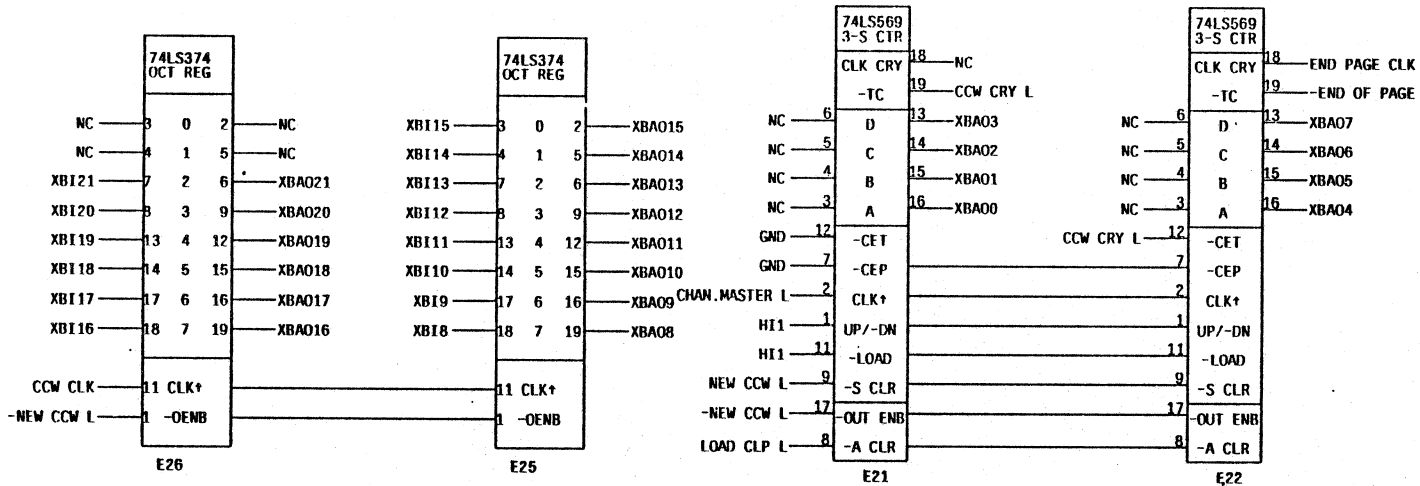

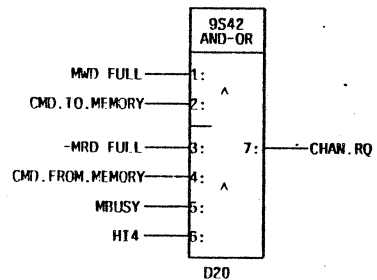
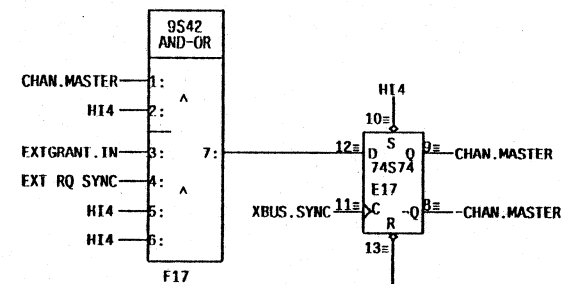
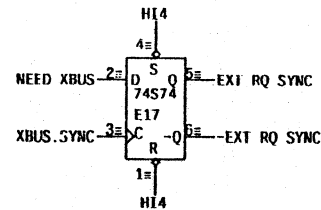
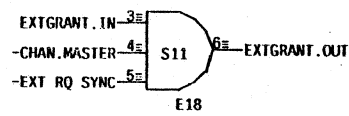
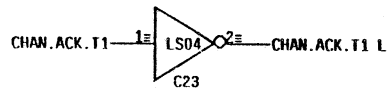
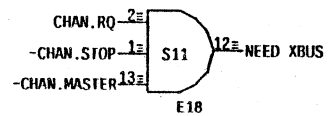
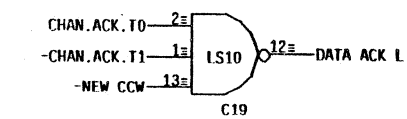

:DELAY FOR OUTPUT PARITY COMPUTATION  
:AND FOR ADDRESS TO SETTLE

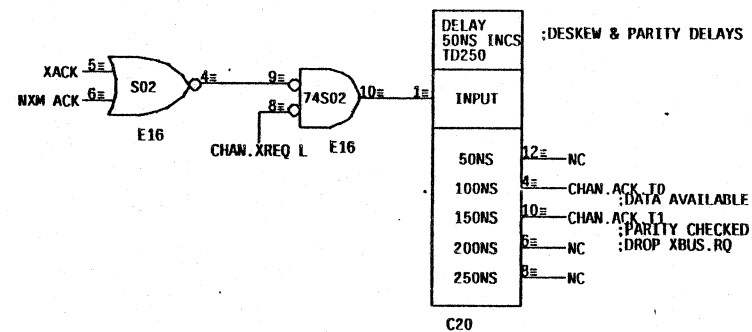
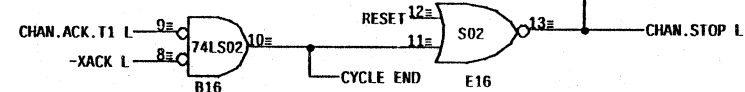
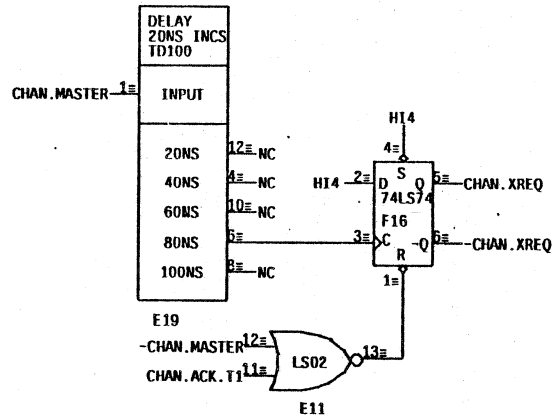

TIMING

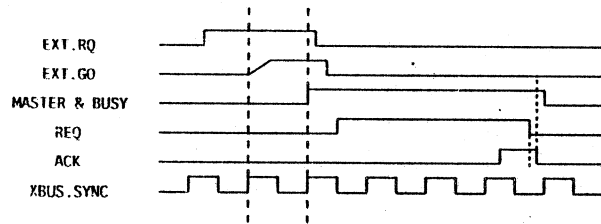

LOGIC IN BUS CONTROLLER

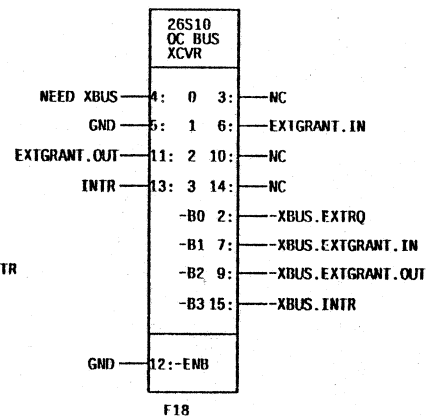
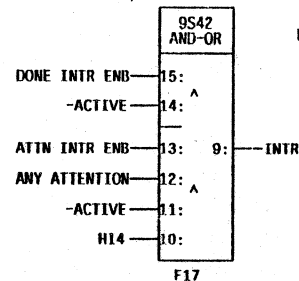
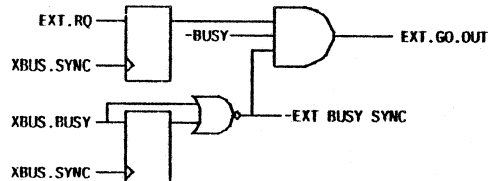

: -XBUS.EXTGRANT.IN Terminated  
: on DCIM01 or MKPANEL

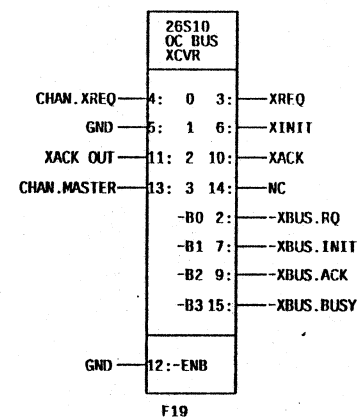

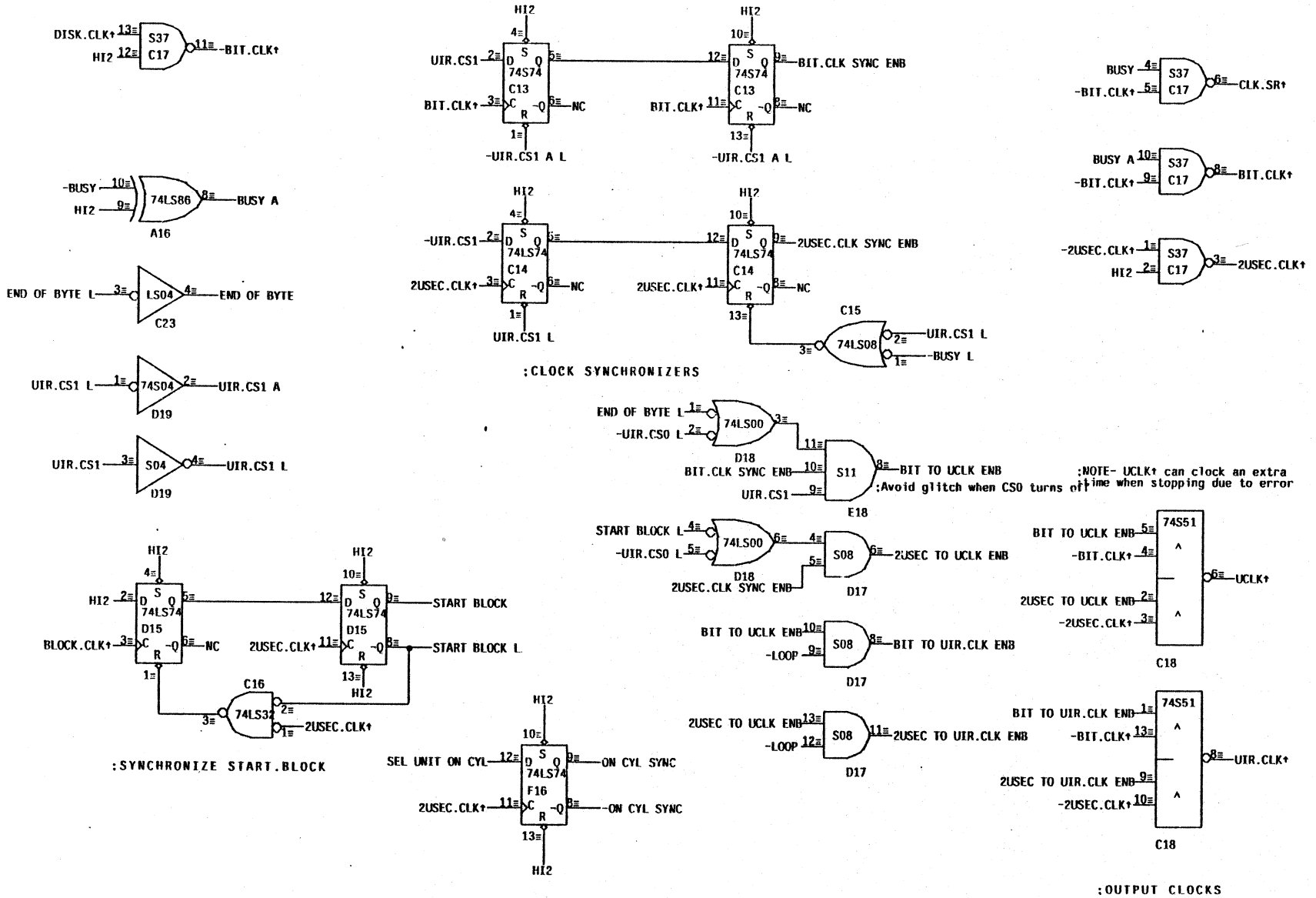

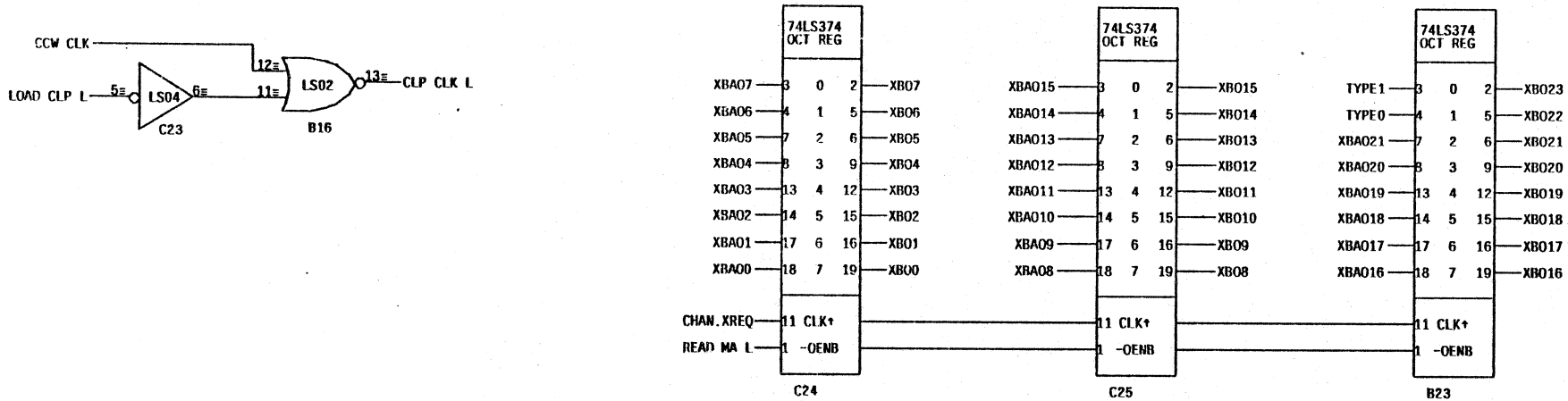
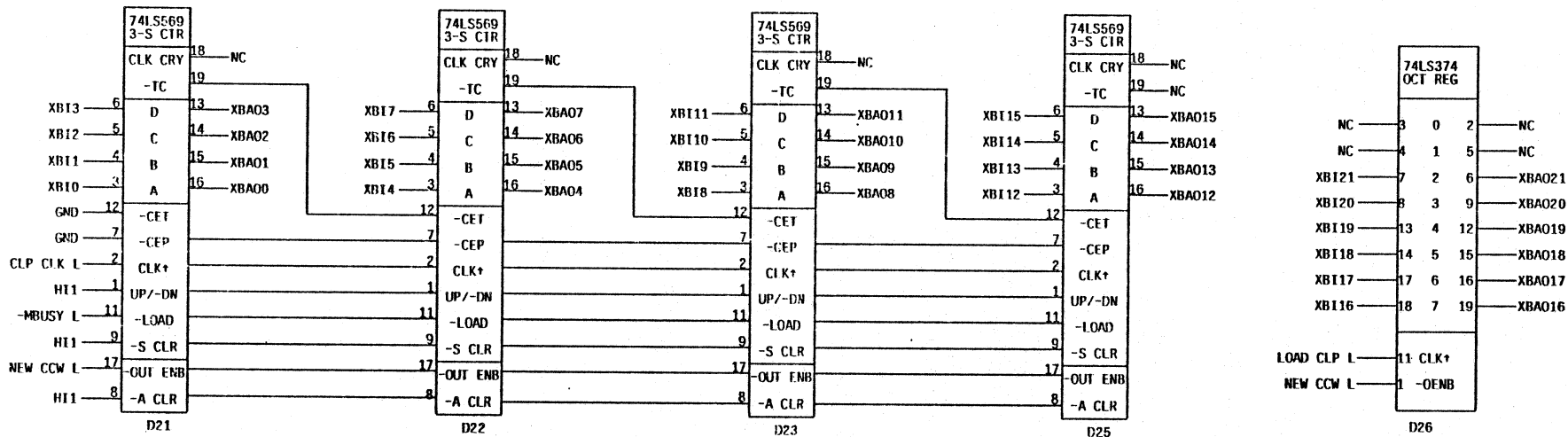



CMD	OPERATION
00	READ
10	READ COMPARE
11	WRITE
02	READ ALL
13	WRITE ALL
04	SEEK
05	AT EASE
1005	RECALIBRATE
405	FAULT CLEAR
06	OFFSET CLEAR
16	STOP, RESET

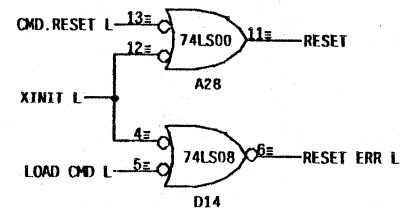
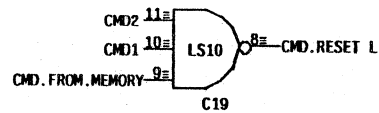
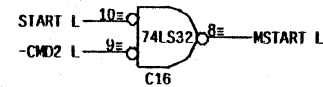
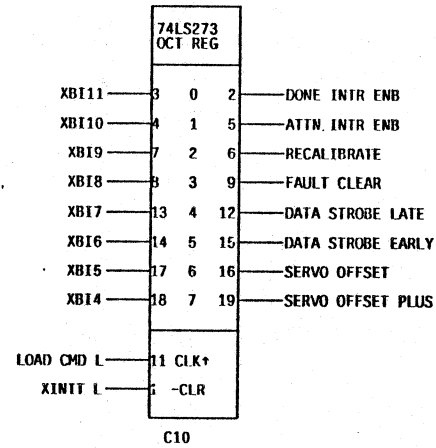
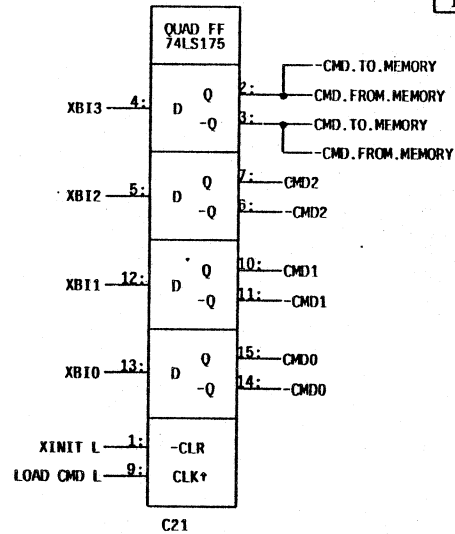

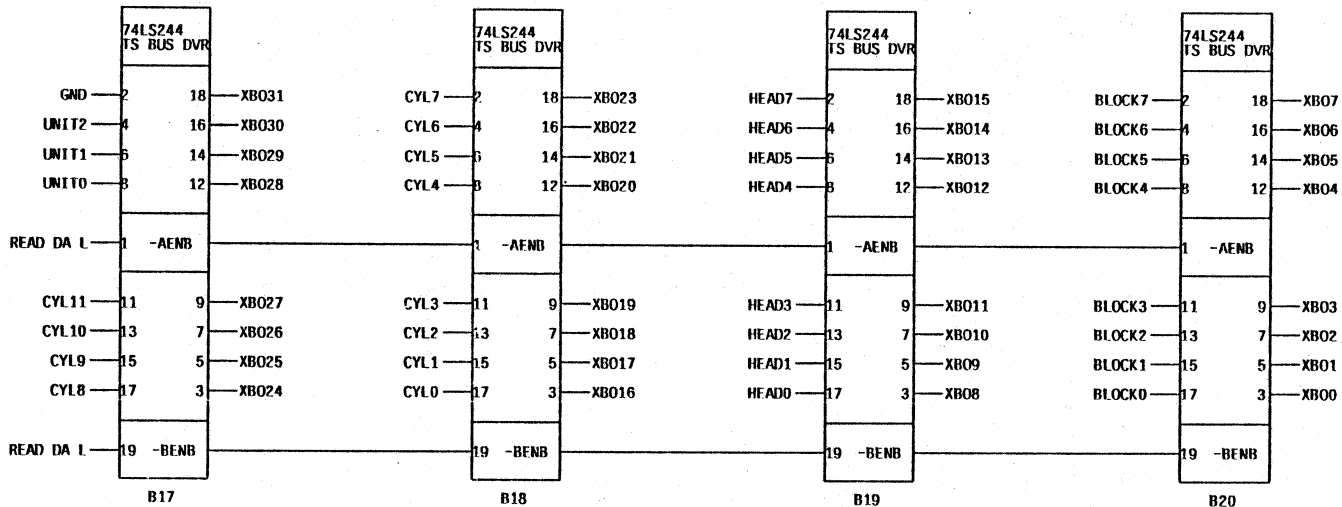
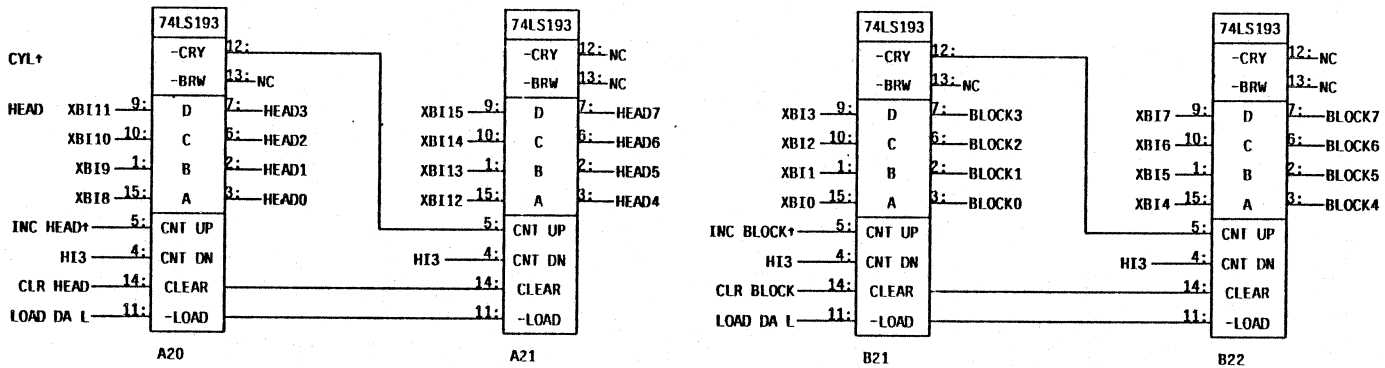
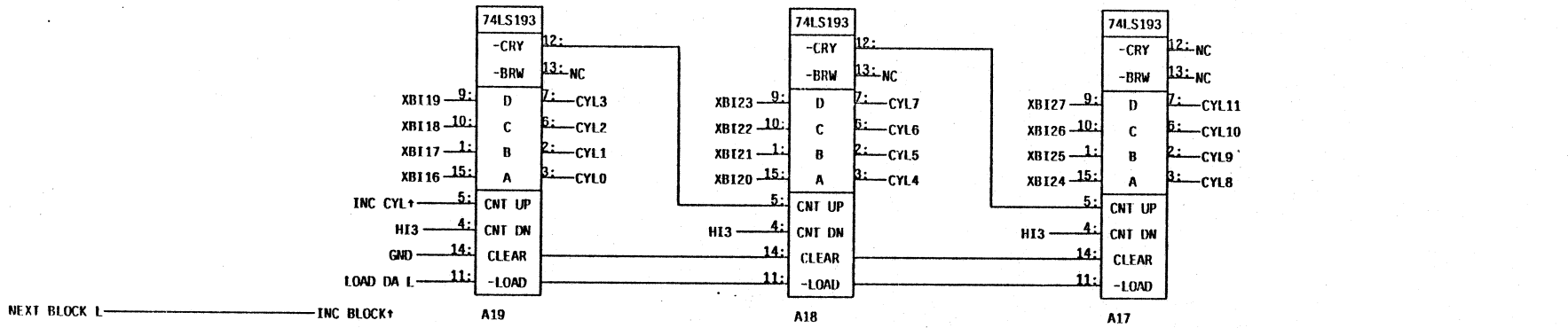

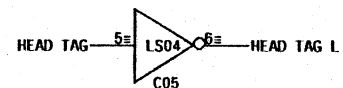
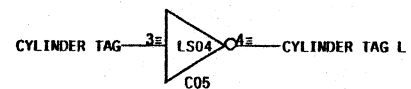
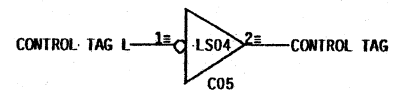
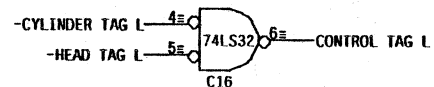
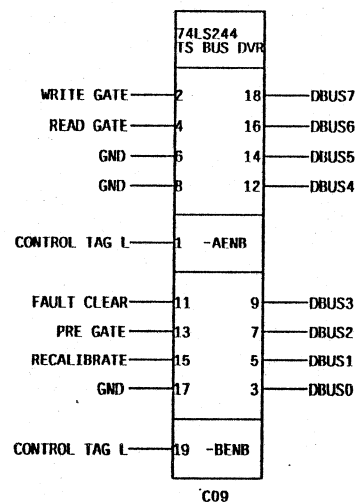
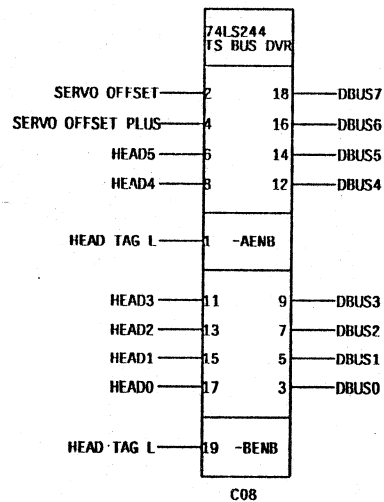
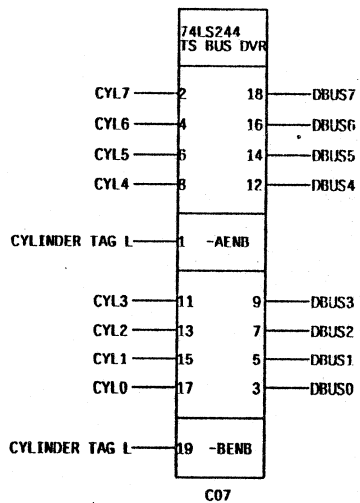
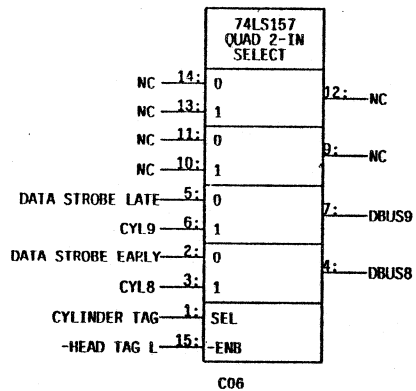

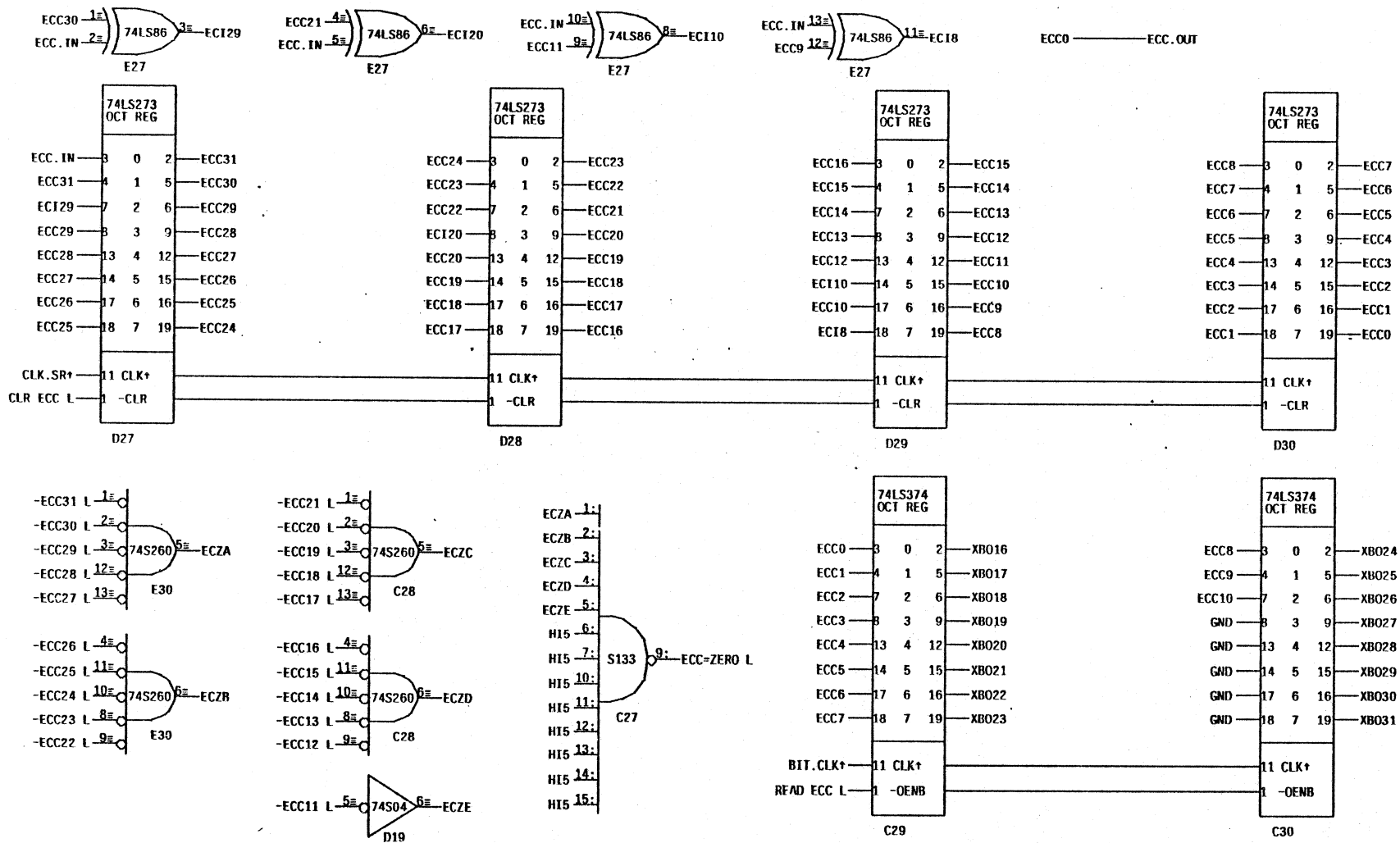

GROUNDS

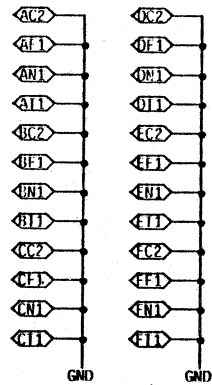

JUMPERS FOR 1-BOARD VERSION:

DE2 - DF2 - DH2  
 DM1 - DM2  
 ET1 - EP2 - ER2 - ES2

OMITTED DIPS IN 2-BOARD VERSION:

A7 A8 A9  
 A10 B7 B8

BE CERTAIN TO EDIT THE  
 RAY FILE FOR UNDEDICATED  
 GROUND PINS ON J1, J3

TO DISK MUX BOARD

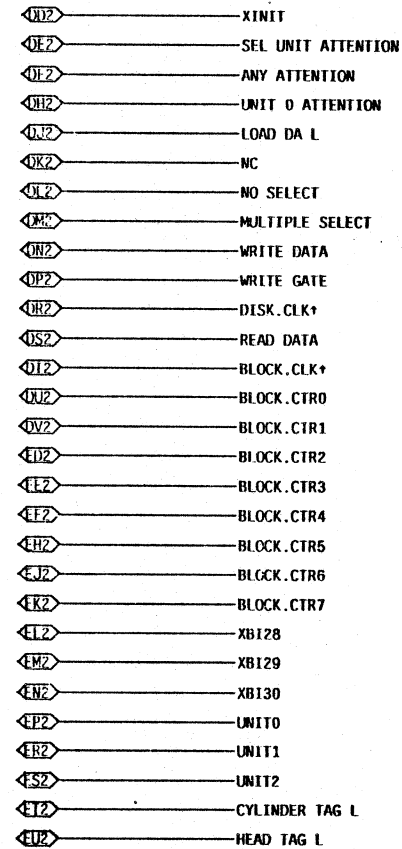

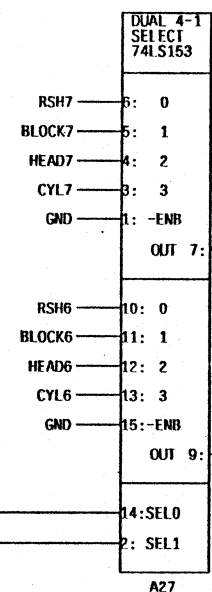
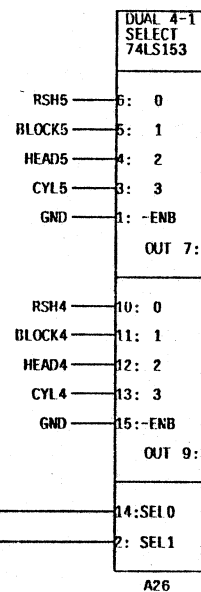
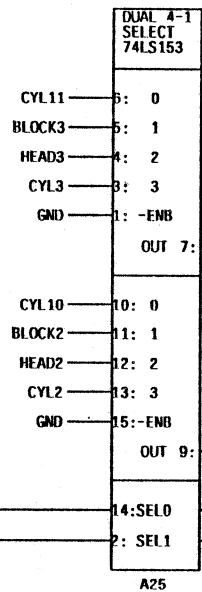
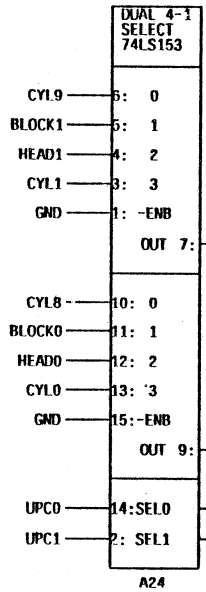
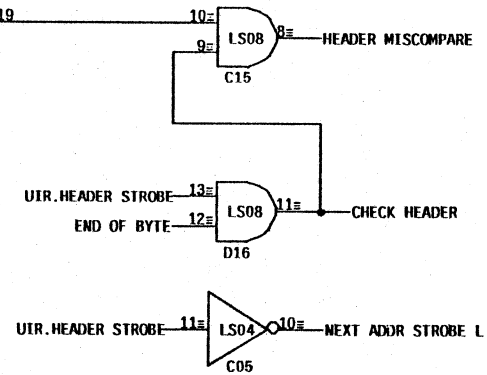
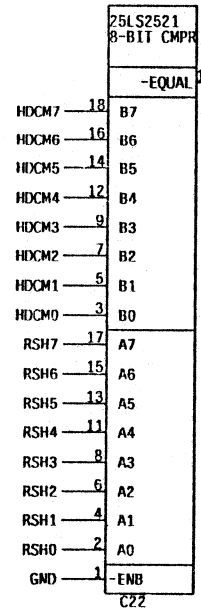
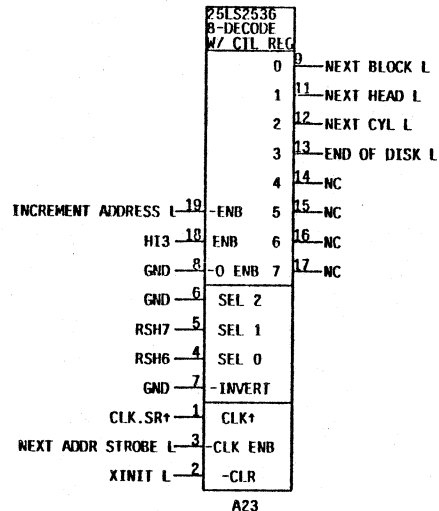
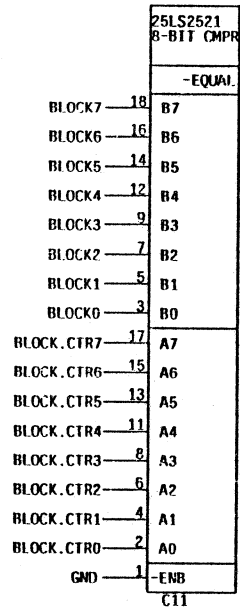

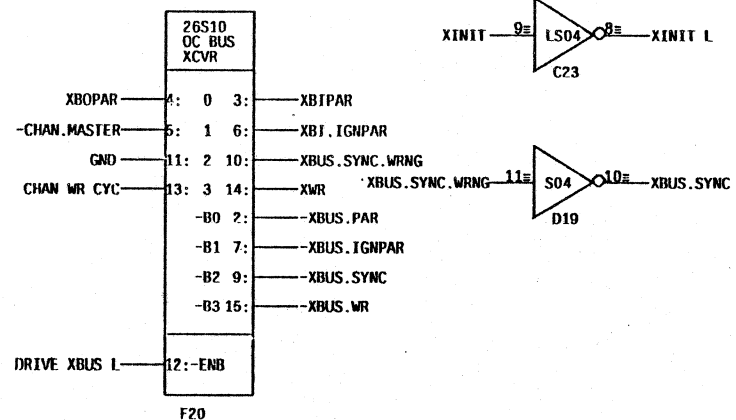
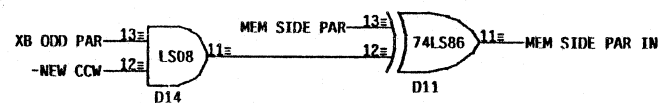
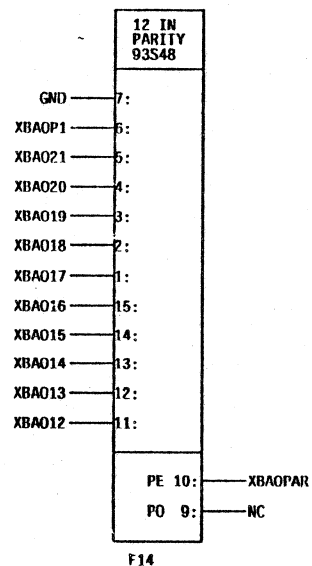
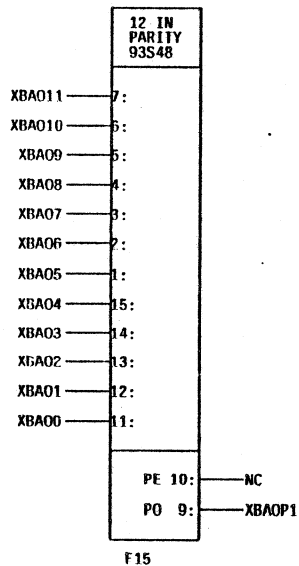
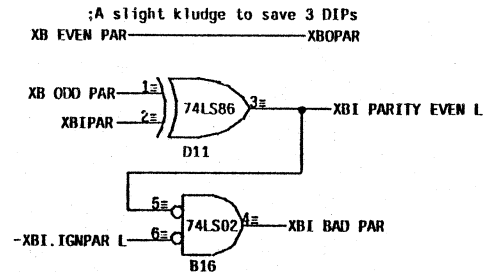
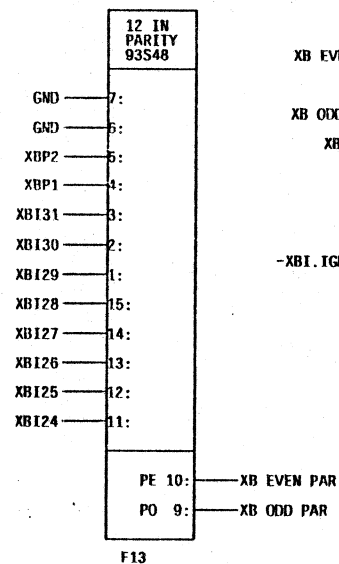
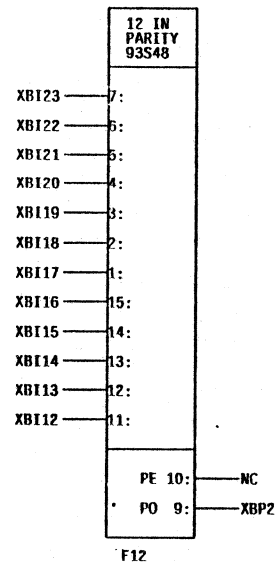
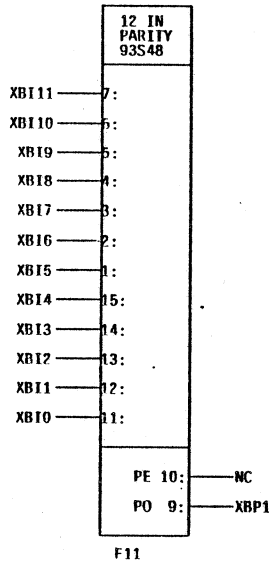

:WHEN READING, HAS ONE LESS THAN THE NUMBER OF  
 : VALID BITS ALREADY CLOCKED IN.  
 :WHEN WRITING, HAS THE NUMBER OF  
 : BITS ALREADY CLOCKED OUT.

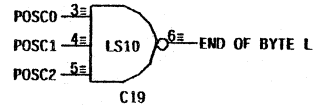

:NOTE SYNCHRONOUS CLEAR

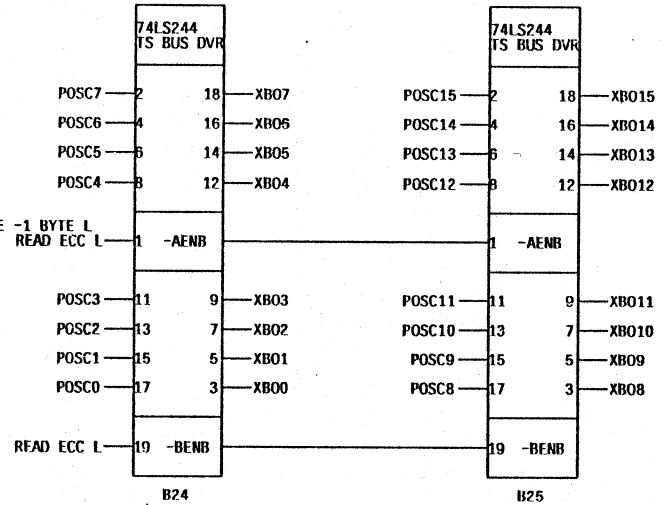
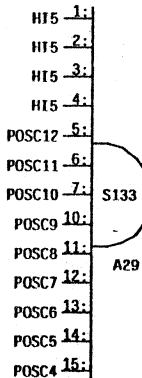
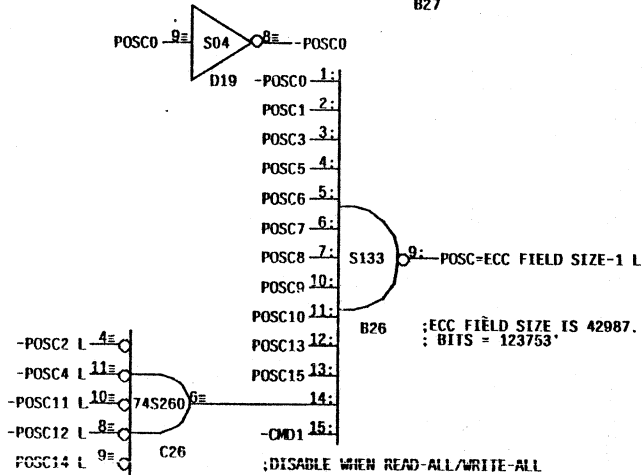
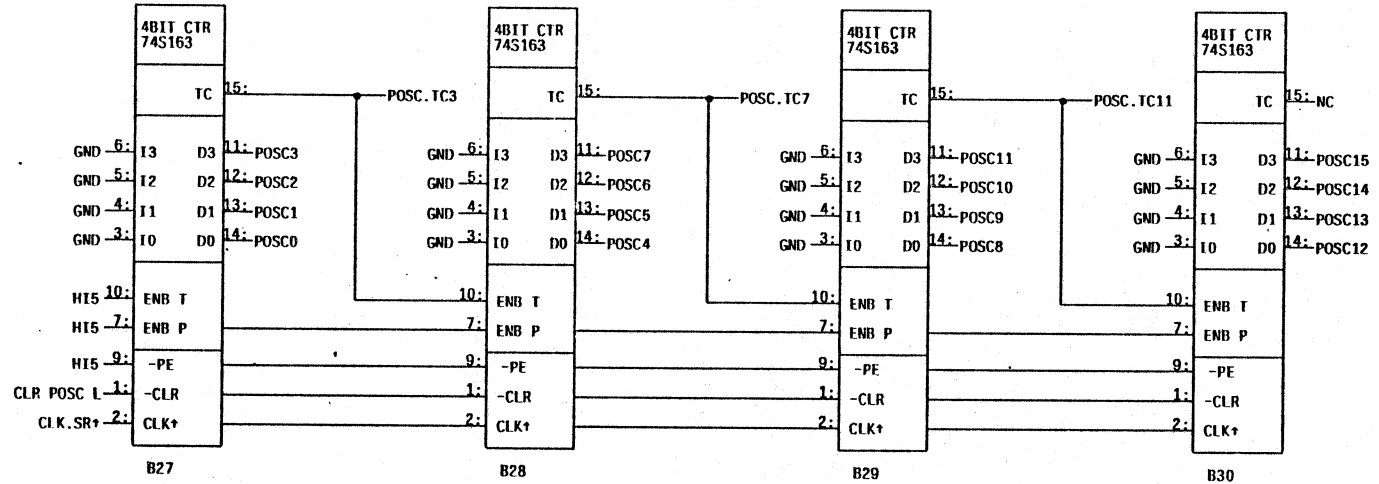



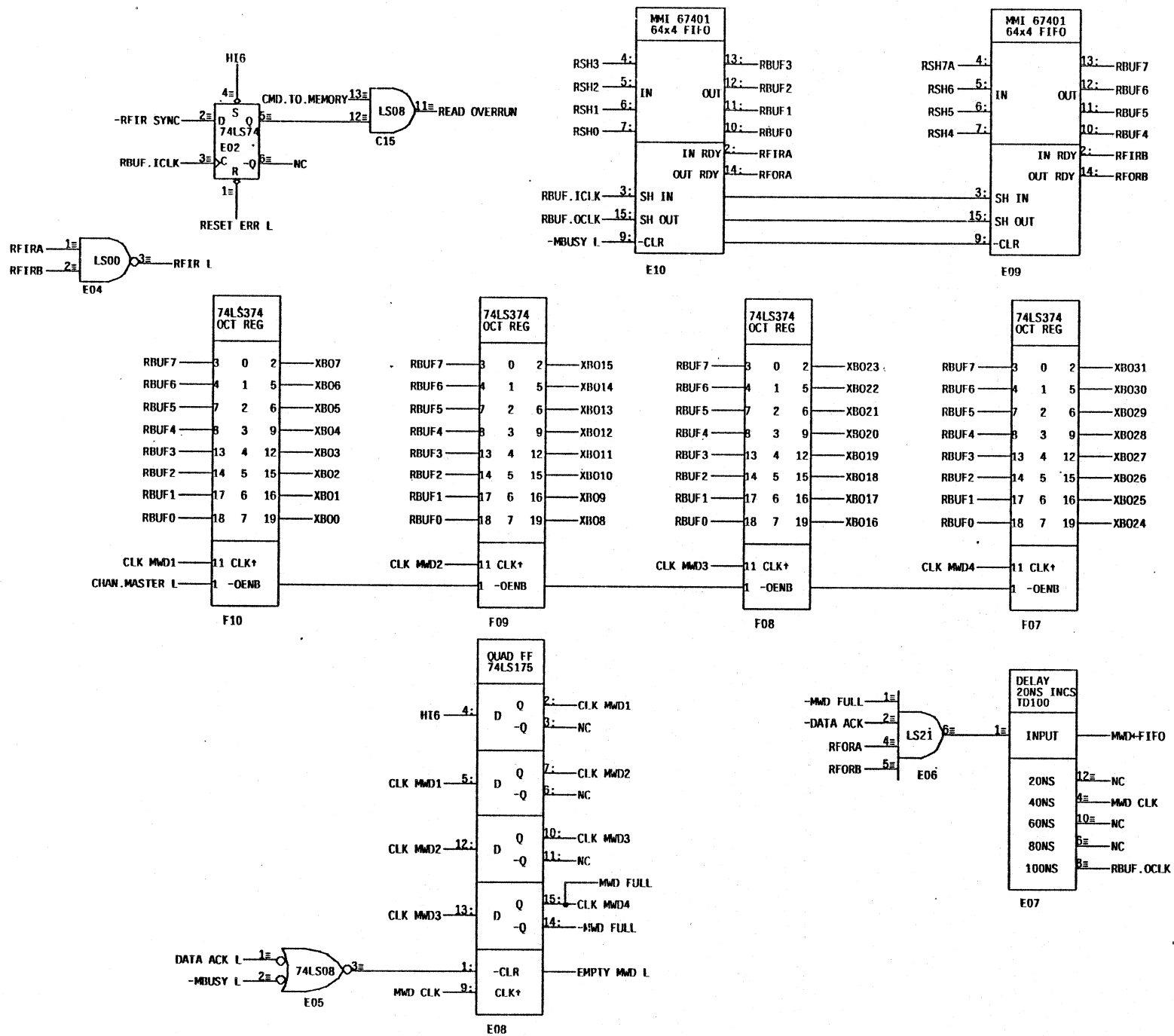

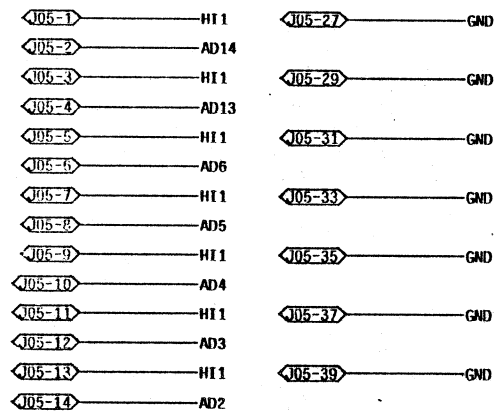
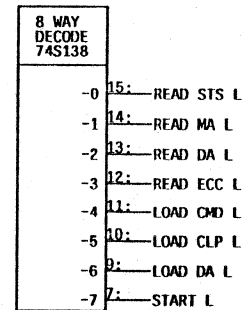
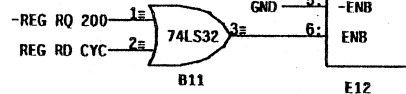
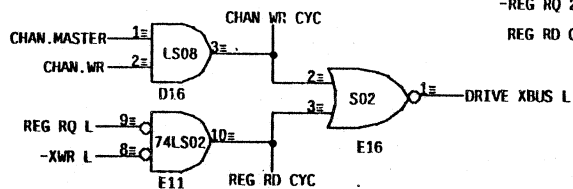
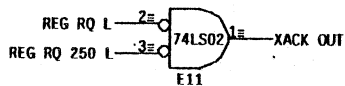
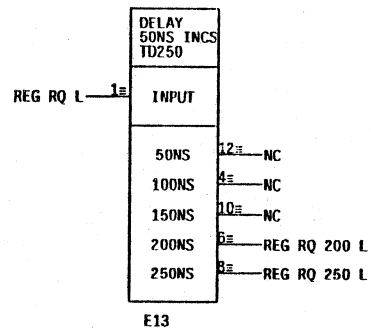
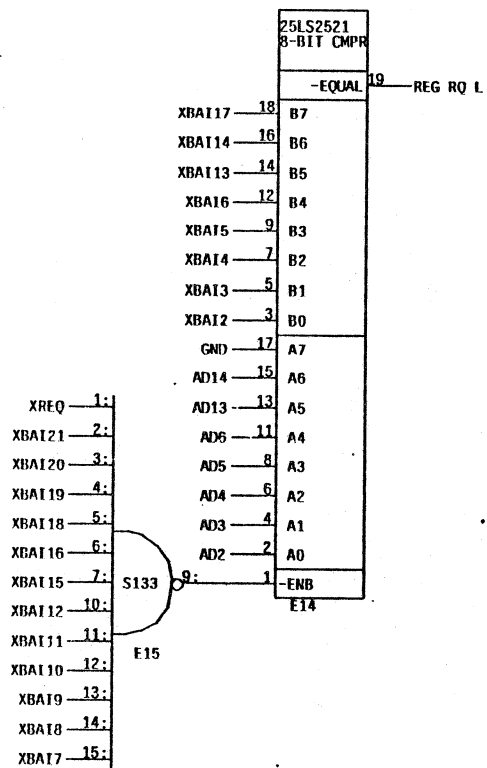

1 7 3 7 7 7 7 4  
1 111 011 xx1 111 11x xxx x--  
ADDRESS

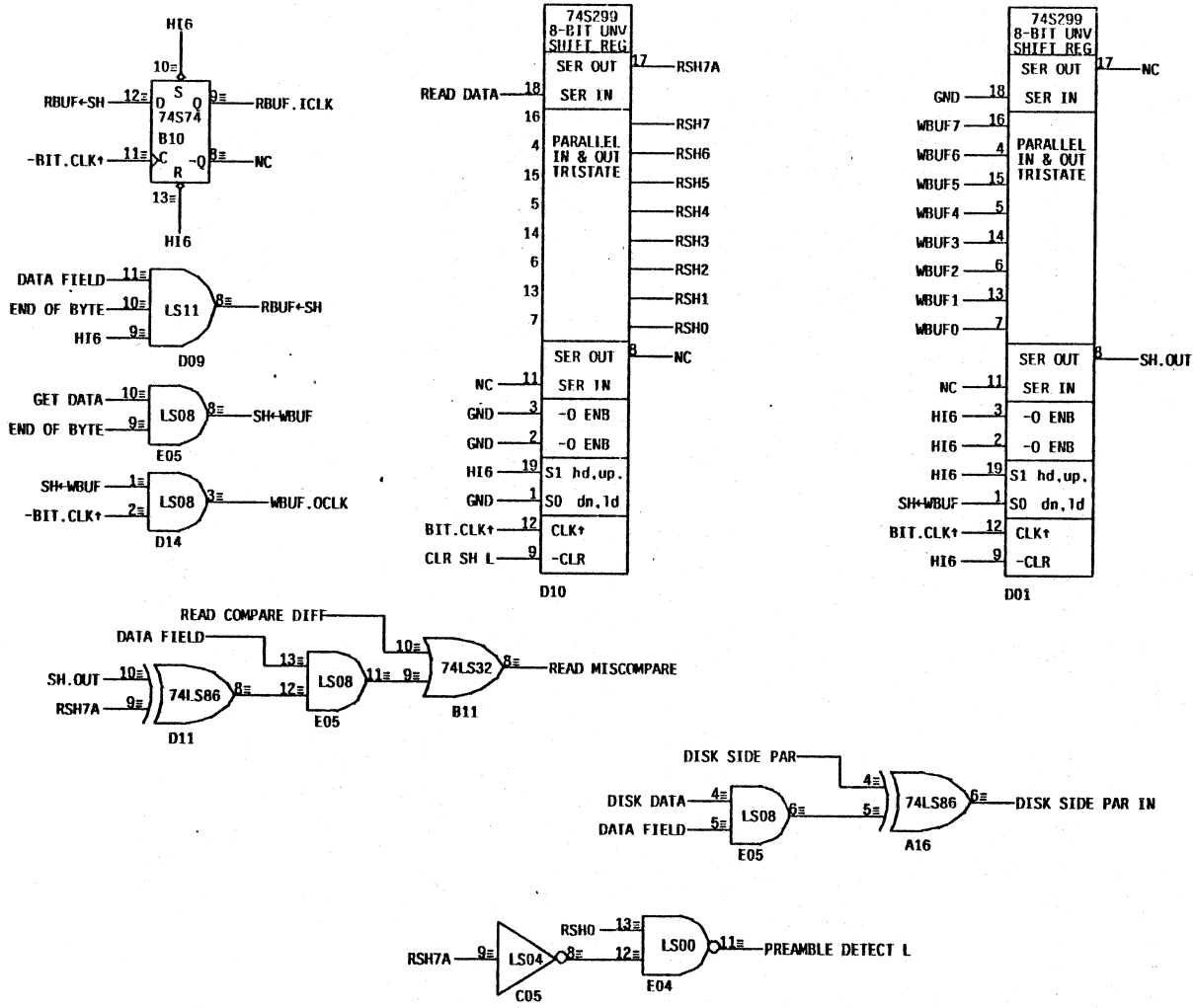

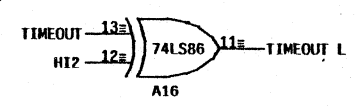
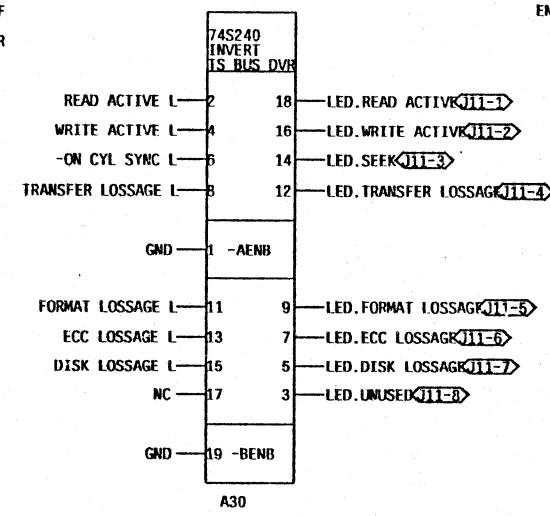
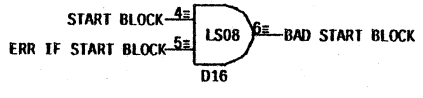
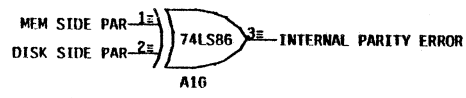
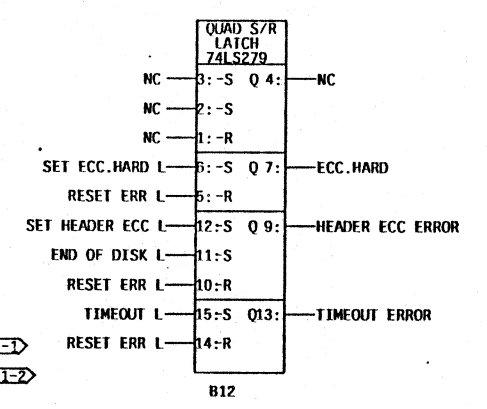
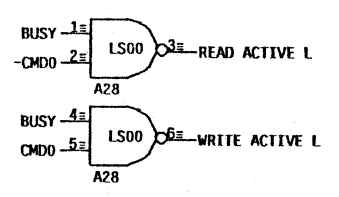
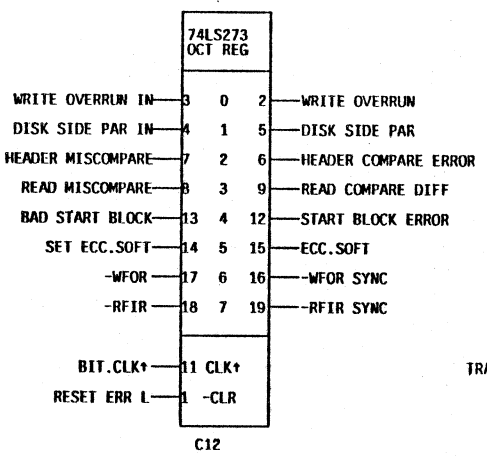
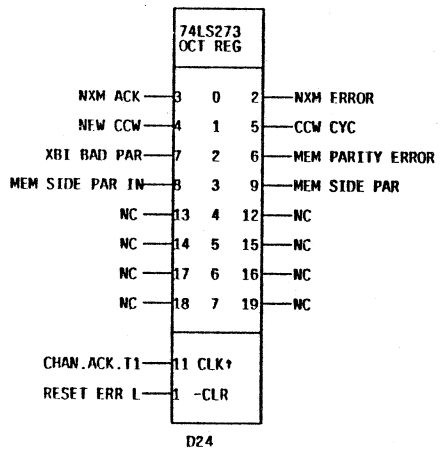
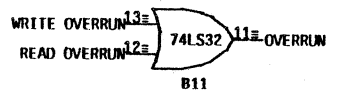
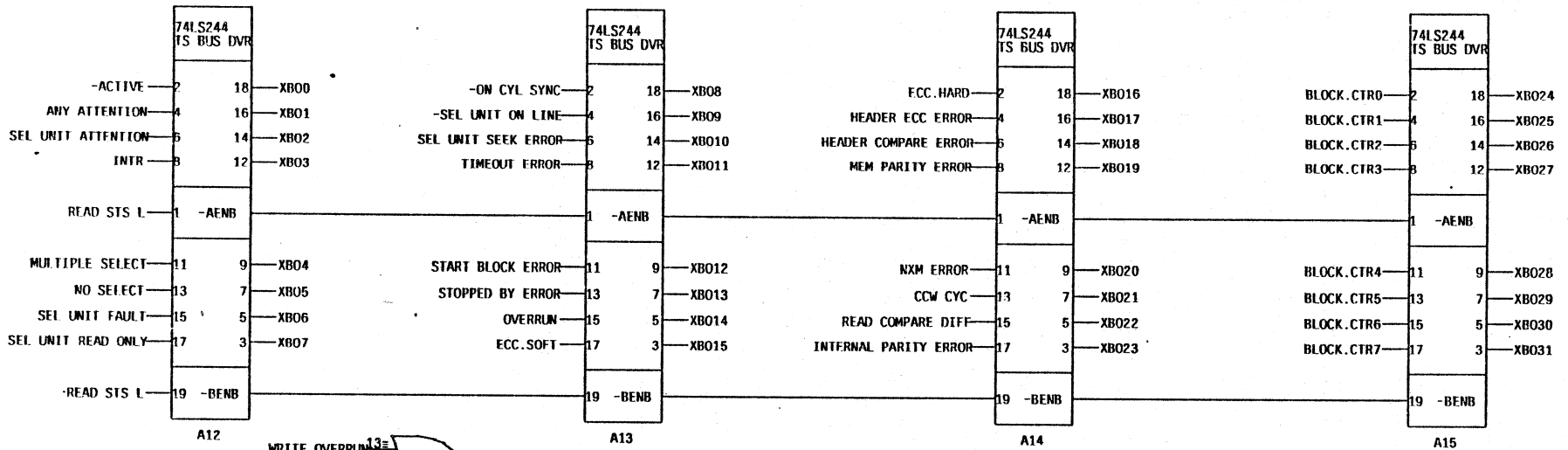

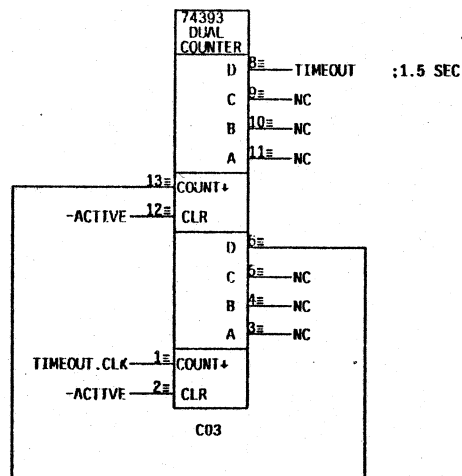
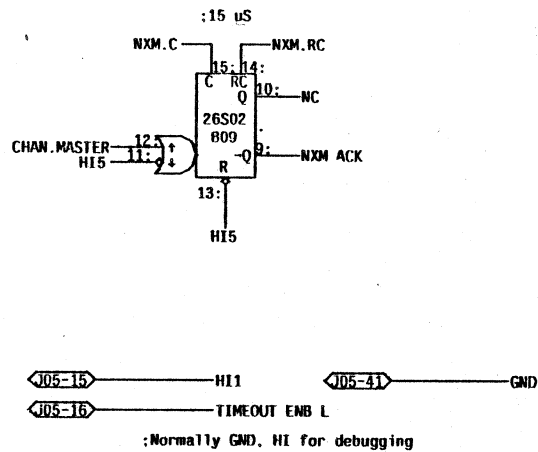
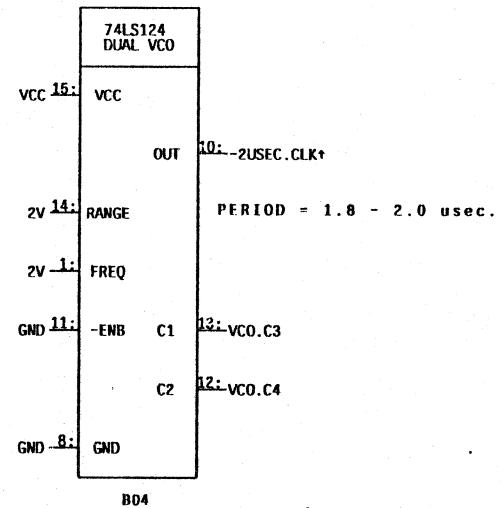
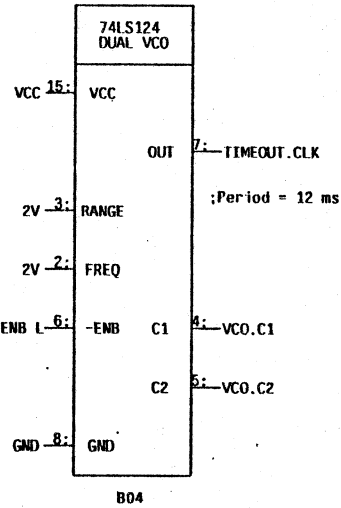
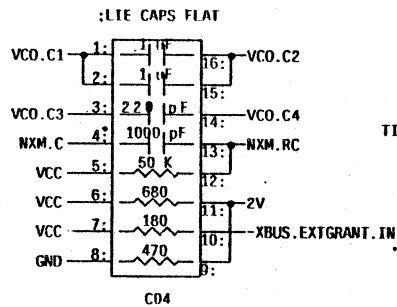

- Ⓜ03-10 — VCC
- Ⓜ03-20 — VCC
- Ⓜ03-29 — GND
- Ⓜ03-20 — TRIDENT.O.COMPSECIDX/
- Ⓜ03-8 — GND
- Ⓜ03-28 — TRIDENT.O.ATTENTION/
- Ⓜ03-7 — GND
- Ⓜ03-27 — TRIDENT.O.SELECTED/
- Ⓜ03-6 — GND
- Ⓜ03-26 — TRIDENT.O.SEQUENCE/
- Ⓜ03-5 — GND
- Ⓜ03-25 — TRIDENT.O.SELECT/
- Ⓜ03-4 — GND
- Ⓜ03-24 — TRIDENT.O.DATA.P
- Ⓜ03-3 — GND
- Ⓜ03-23 — TRIDENT.O.DATA.M
- Ⓜ03-2 — GND
- Ⓜ03-22 — TRIDENT.O.CLOCK.P
- Ⓜ03-1 — GND
- Ⓜ03-21 — TRIDENT.O.CLOCK.M

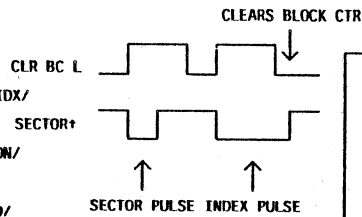

:Set sector length jumpers  
:drive to 1410 (octal)  
:which is 1164. bytes.

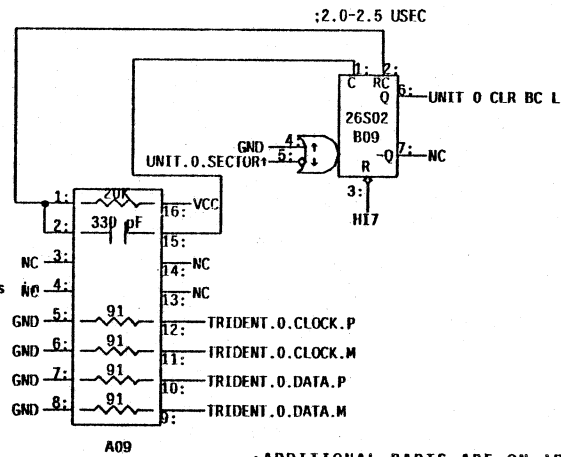

:ADDITIONAL PARTS ARE ON 'DCTRSG'

GND — TYPE1  
GND — TYPE0  
:Trident is type 0

:J3. remove dedicated grounds 21-30  
:Delete pins 11 and 31

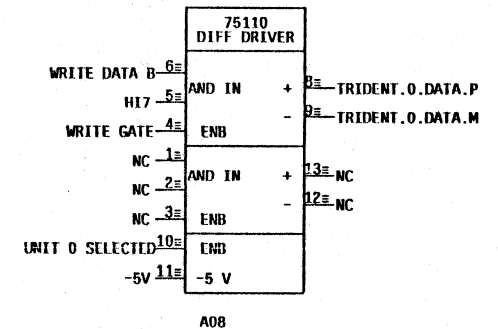
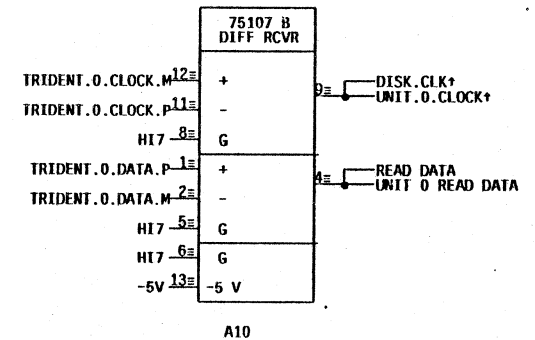
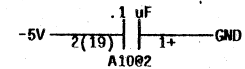
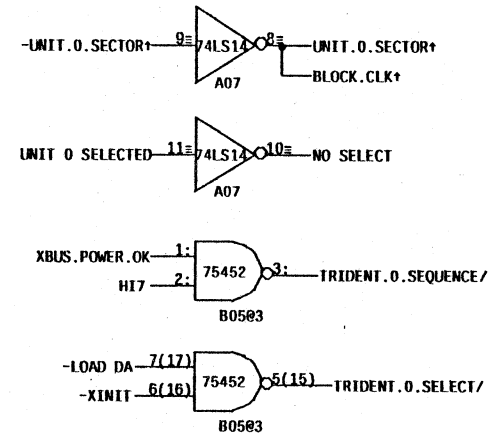
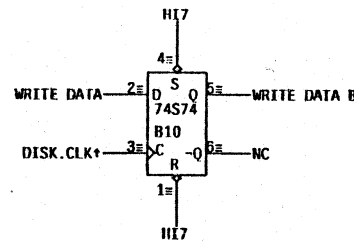
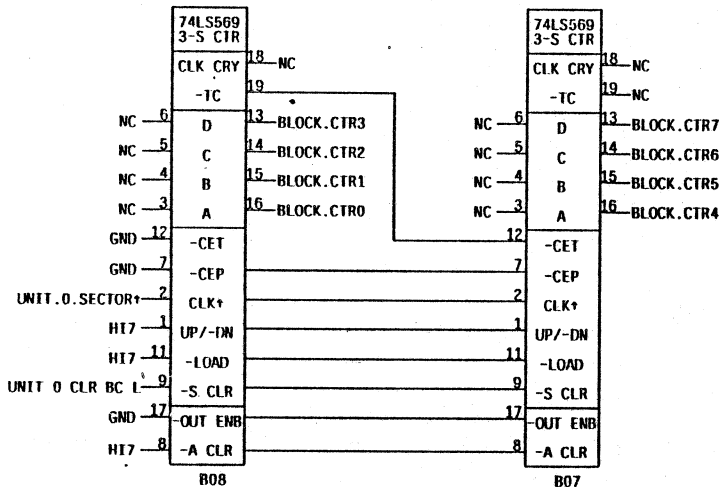

- ◀ J01-20 — TRIDENT\_SECTOR/
  - ◀ J01-45 — TRIDENT\_END\_OF\_CYL/
  - ◀ J01-19 — TRIDENT\_ADDR\_MK\_DET/
  - ◀ J01-44 — TRIDENT\_OFFSET/
  - ◀ J01-18 — VCC
  - ◀ J01-43 — TRIDENT\_INDEX/
  - ◀ J01-17 — VCC
  - ◀ J01-42 — TRIDENT\_READY/
  - ◀ J01-16 — GND
  - ◀ J01-41 — TRIDENT\_READ\_ONLY/
  - ◀ J01-15 — GND
  - ◀ J01-40 — TRIDENT\_DEVICE\_CHECK/
  - ◀ J01-14 — GND
  - ◀ J01-39 — TRIDENT\_ON\_LINE/
  - ◀ J01-13 — GND
  - ◀ J01-38 — TRIDENT\_SEEK\_INC/
  - ◀ J01-12 — GND
  - ◀ J01-37 — TRIDENT\_SPARE/
  - ◀ J01-11 — GND
  - ◀ J01-36 — TRIDENT\_BUS9/
  - ◀ J01-10 — GND
  - ◀ J01-35 — TRIDENT\_BUS8/
  - ◀ J01-9 — GND
  - ◀ J01-34 — TRIDENT\_BUS7/
  - ◀ J01-8 — GND
  - ◀ J01-33 — TRIDENT\_BUS6/
  - ◀ J01-7 — GND
  - ◀ J01-32 — TRIDENT\_BUS5/
  - ◀ J01-6 — GND
  - ◀ J01-31 — TRIDENT\_BUS4/
  - ◀ J01-5 — GND
  - ◀ J01-30 — TRIDENT\_BUS3/
  - ◀ J01-4 — GND
  - ◀ J01-29 — TRIDENT\_BUS2/
  - ◀ J01-3 — TRIDENT\_TER\_IM/
  - ◀ J01-28 — TRIDENT\_BUS1/
  - ◀ J01-2 — TRIDENT\_CONTROL\_TAG/
  - ◀ J01-27 — TRIDENT\_BUS0/
  - ◀ J01-1 — TRIDENT\_CYL\_TAG/
  - ◀ J01-26 — TRIDENT\_HEAD\_TAG/
- : J1, remove dedicated gnds 26-45  
: Delete pins 21 and 46

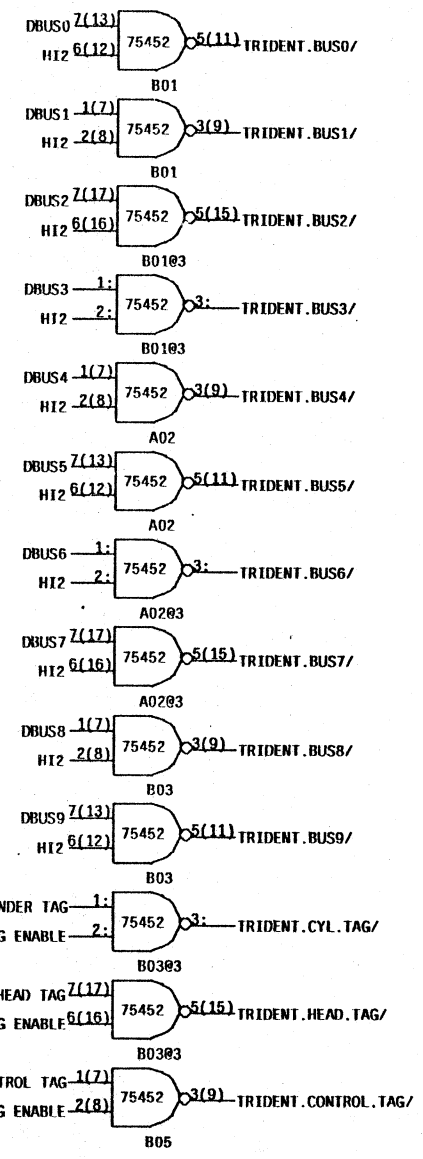
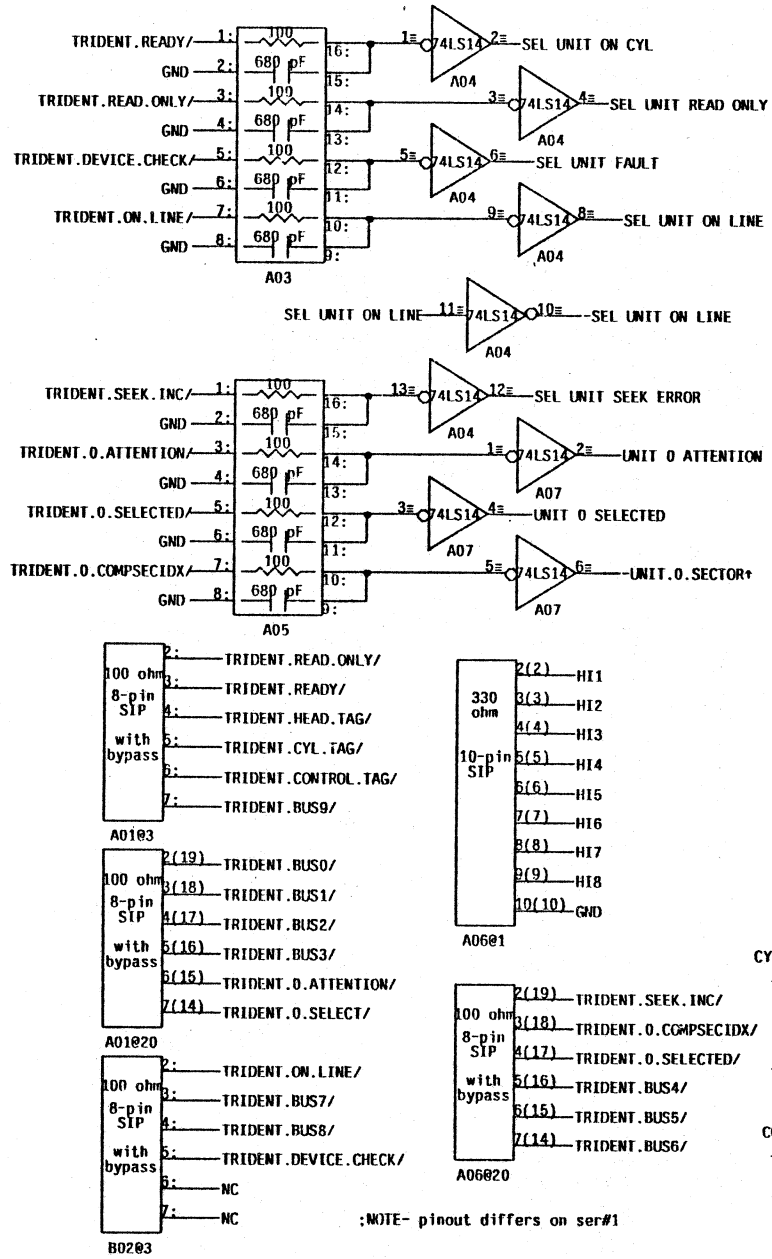

:NOTE- pinout differs on ser#1

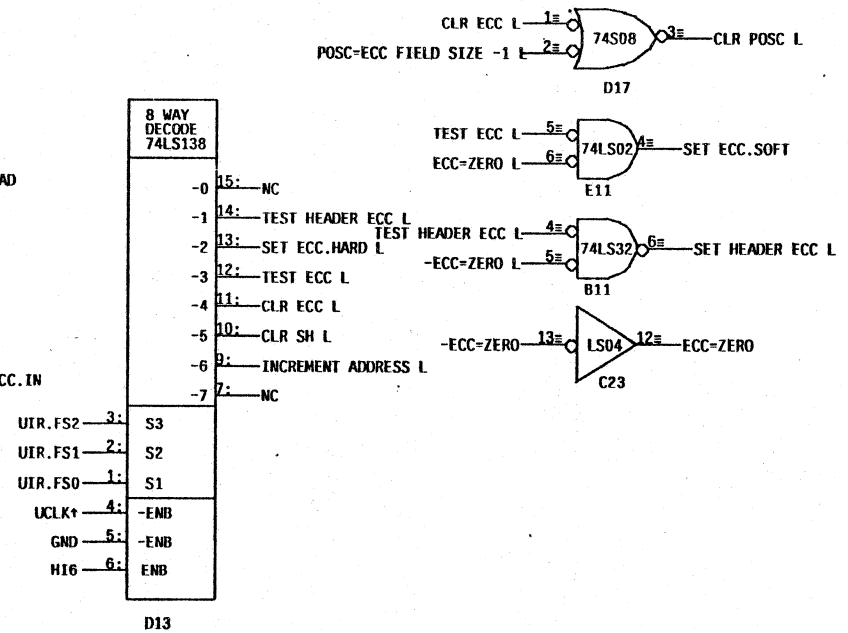
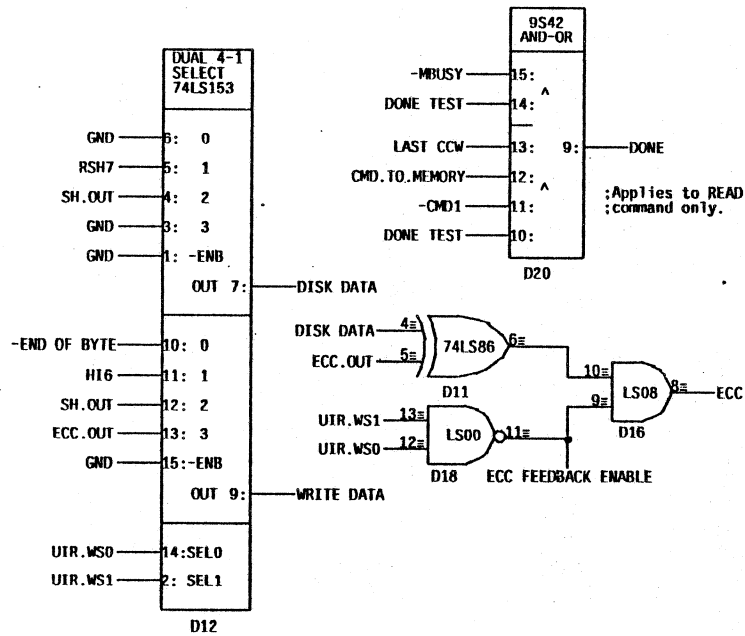
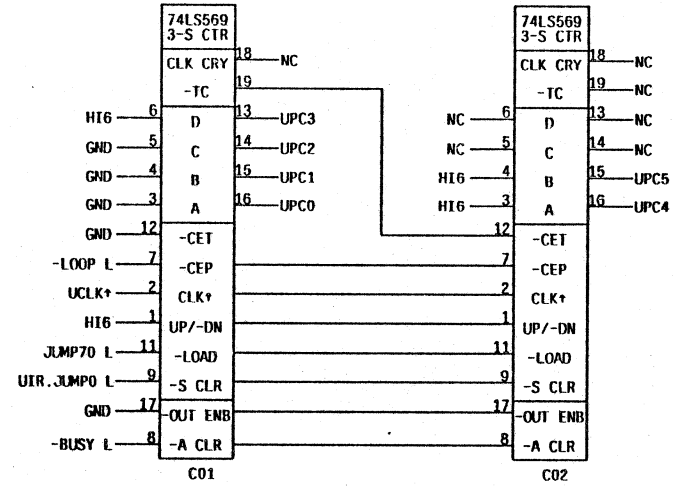
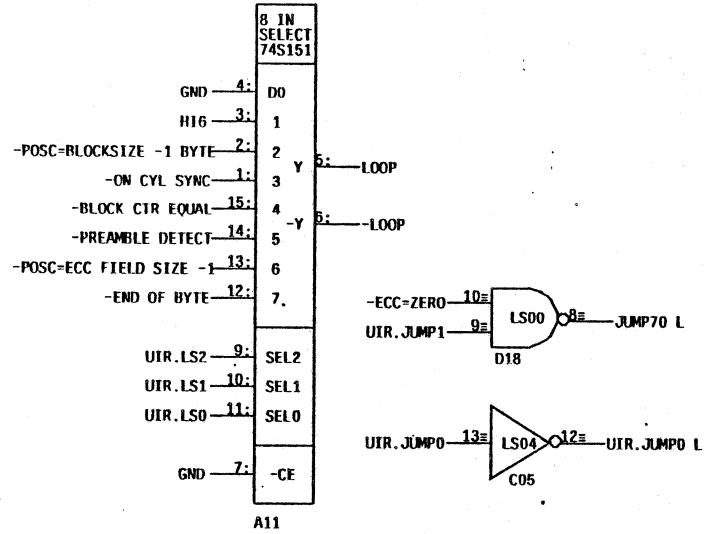



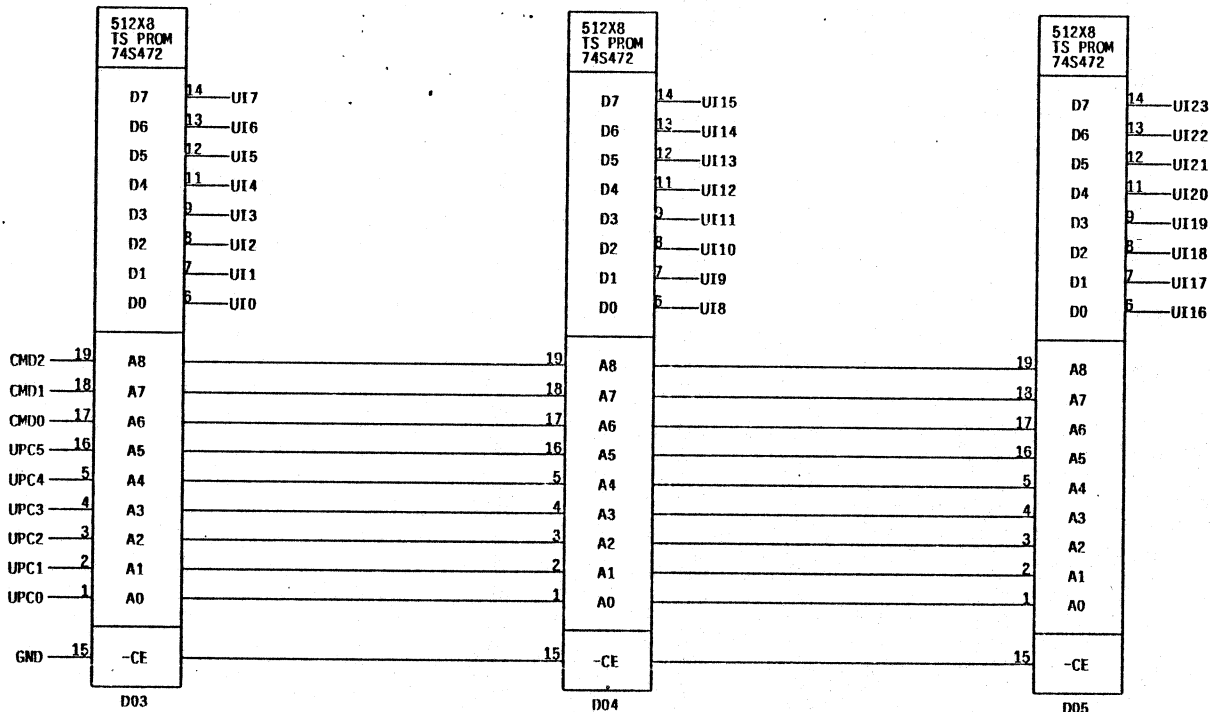
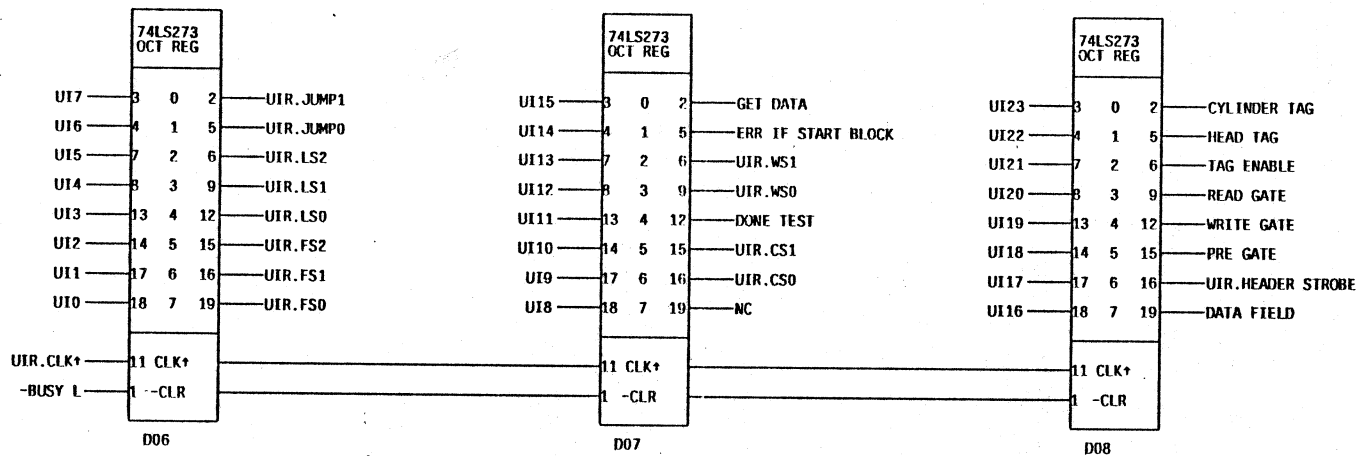

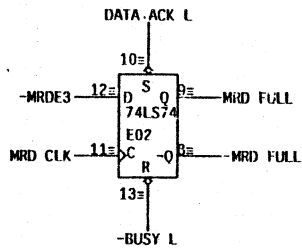
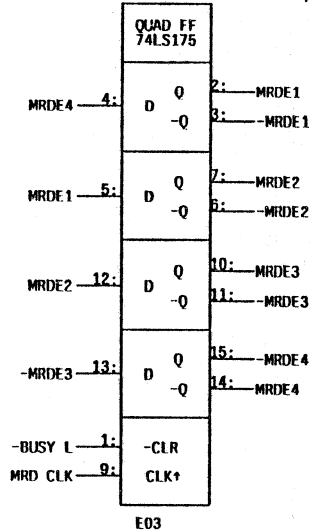
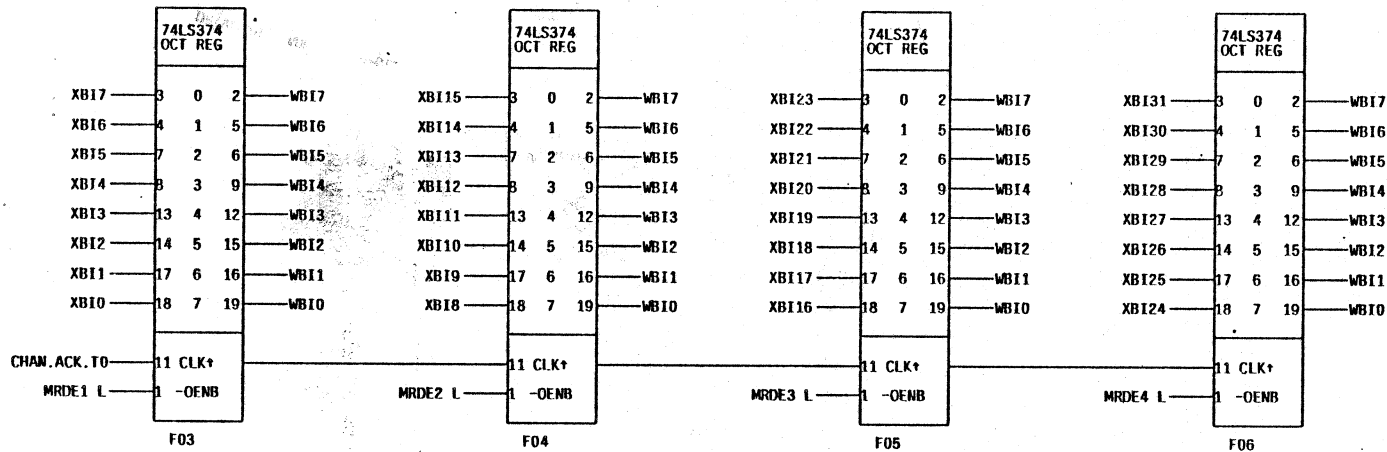
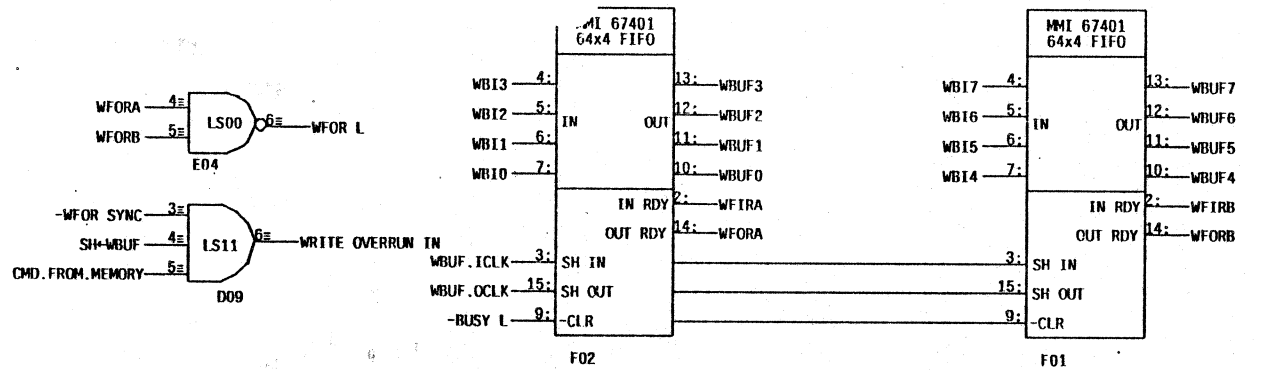

;Idle state has MRDE4 asserted.  
 ;MRD FULL clears on same clock  
 ;that sets MRDE4. Fifo will  
 ;always gobble byte within 105 ns  
 ;before channel can clobber it.

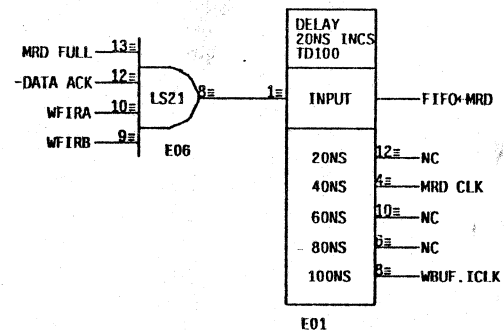

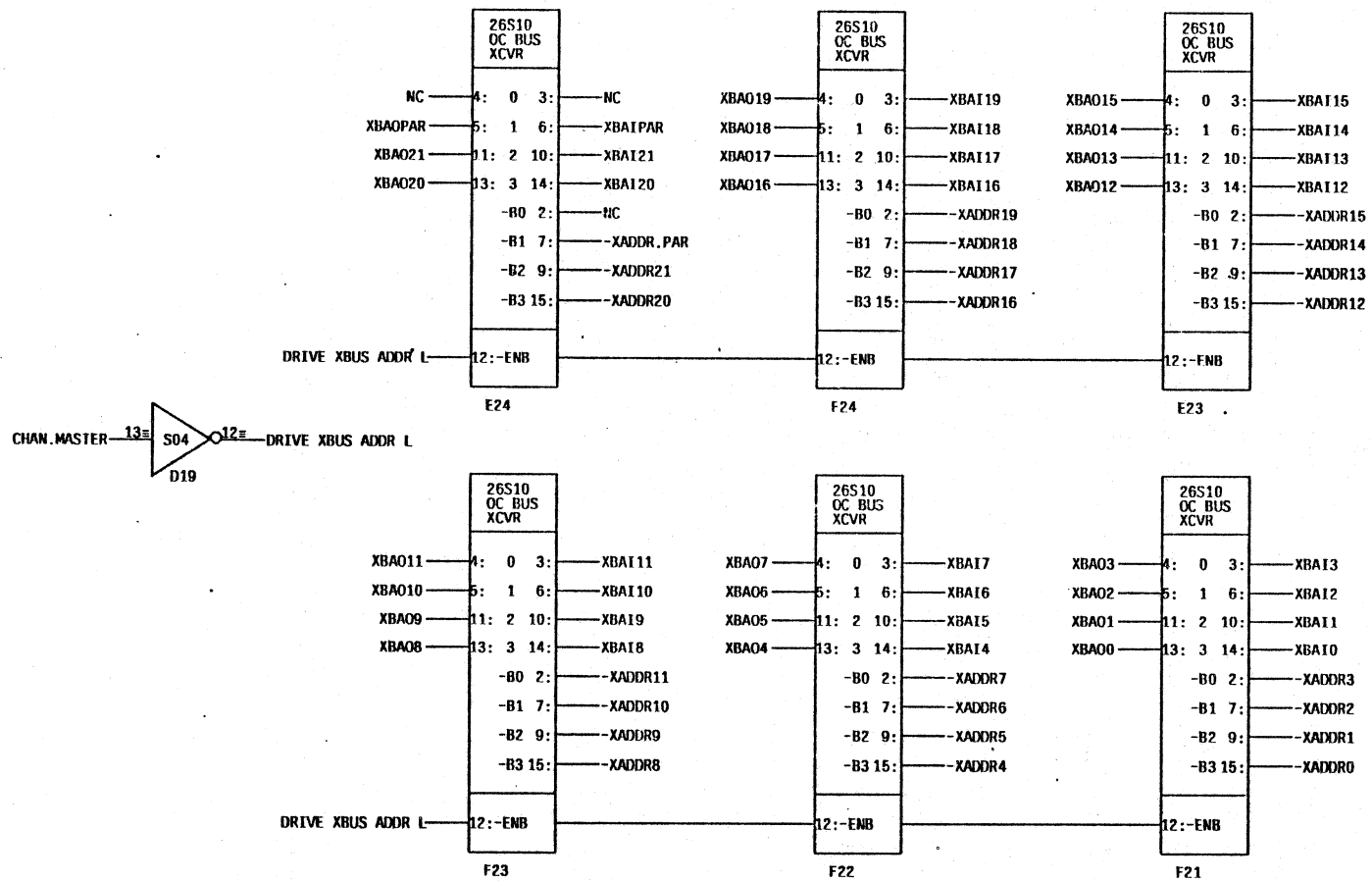

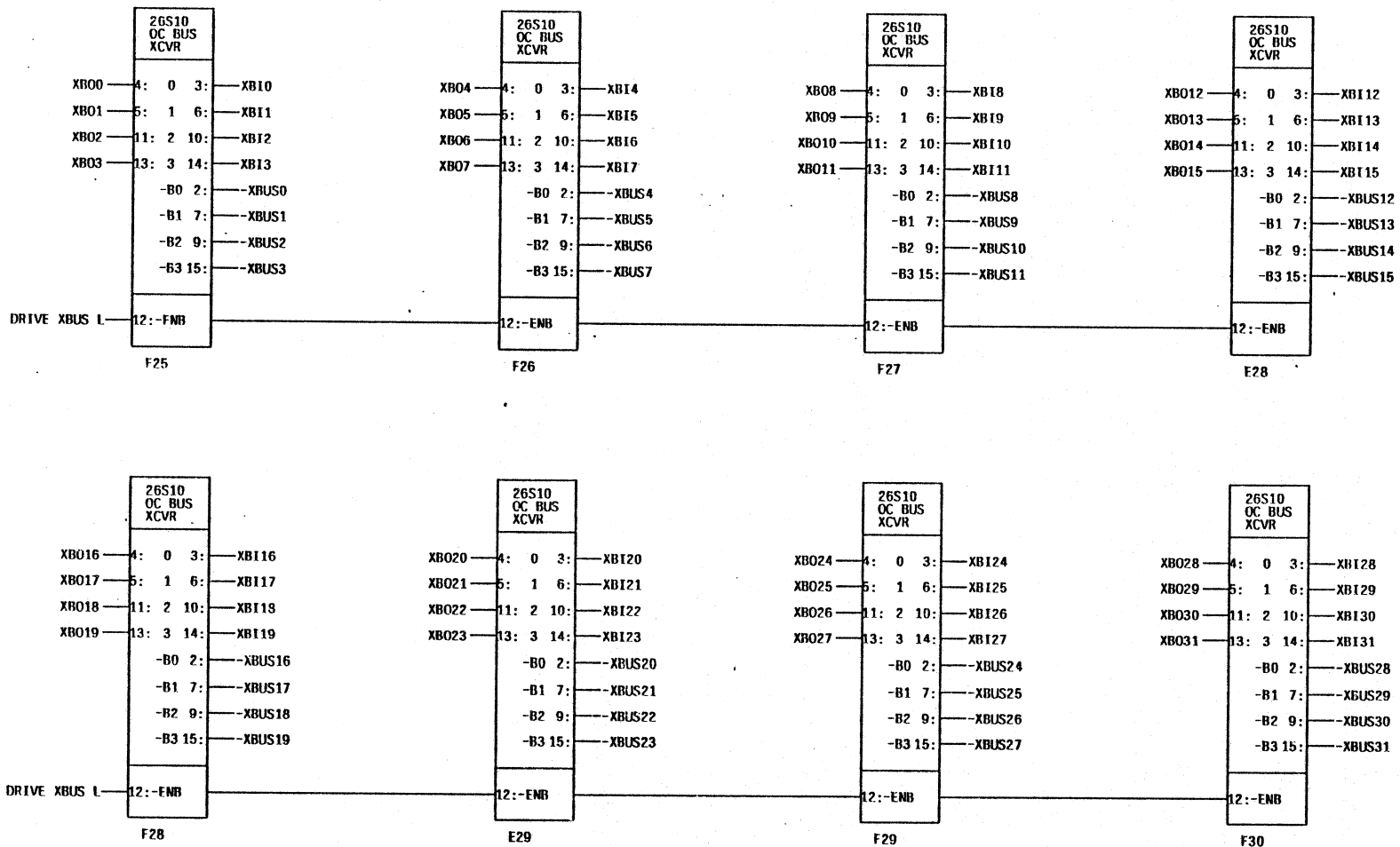

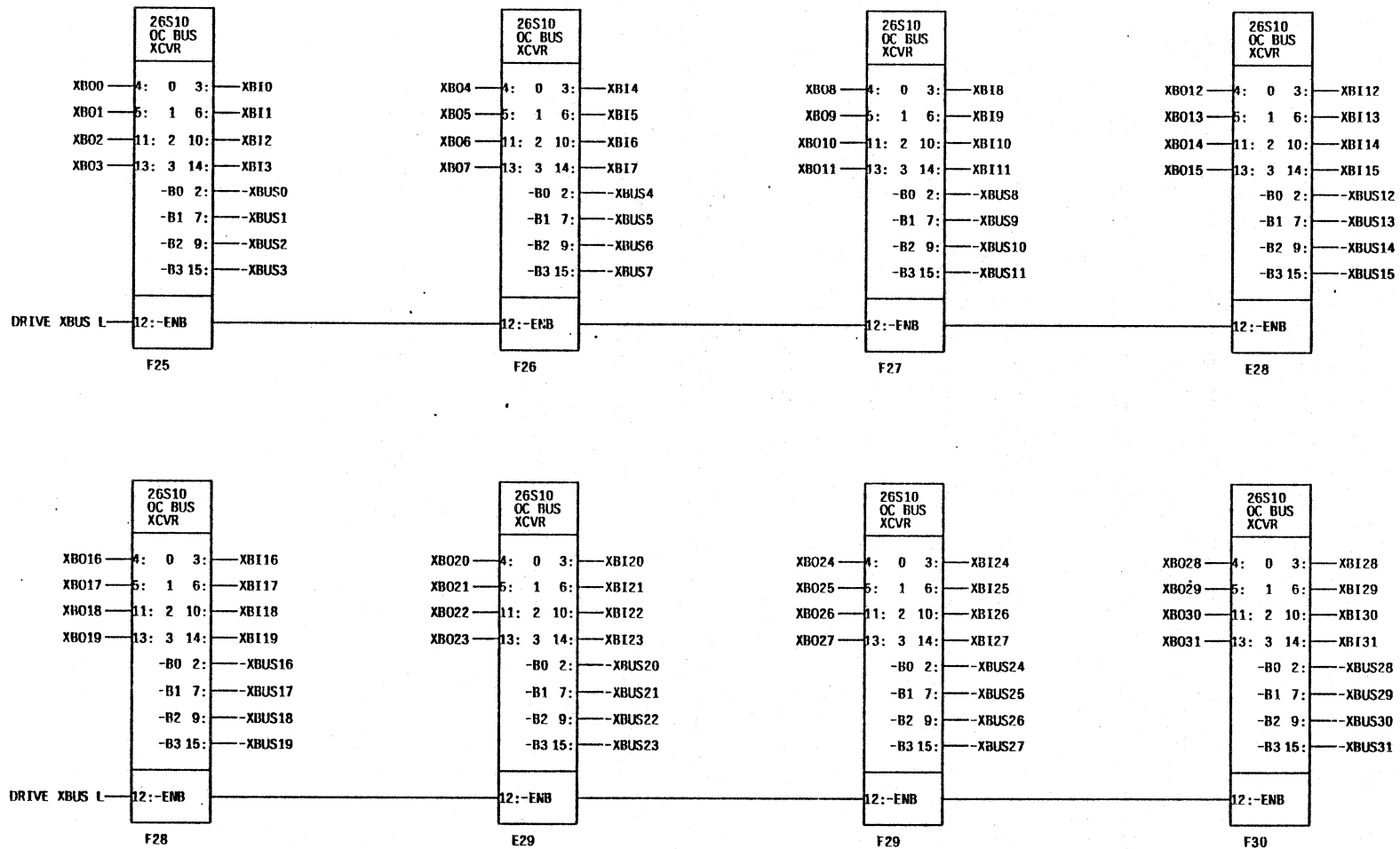

AC2 — GND  
 AF1 — GND  
 AM1 — GND  
 AT1 — GND  
 BC2 — GND  
 BE1 — GND  
 BN1 — GND  
 BJ1 — GND  
 CC2 — GND  
 CE1 — GND  
 CN1 — GND  
 CJ1 — GND

OP1 — +12V  
 OR1 — +12V  
 OS1 — +12V

AE2 — -5V  
 BE2 — -5V  
 CE2 — -5V  
 DE2 — -5V  
 EE2 — -5V  
 FE2 — -5V

AA2 — +5V  
 BA2 — +5V  
 CA2 — +5V  
 DA2 — +5V  
 EA2 — +5V  
 FA2 — +5V

BE2 — -XBUS.PAR  
 BF1 — -XBUS0  
 BD2 — -XBUS1  
 BU1 — -XBUS2  
 BC1 — -XBUS3  
 BB1 — -XBUS4  
 BA1 — -XBUS5  
 AV2 — -XBUS6  
 AV1 — -XBUS7  
 AU2 — -XBUS8  
 AU1 — -XBUS9  
 AT2 — -XBUS10  
 AS2 — -XBUS11  
 AS1 — -XBUS12  
 AR2 — -XBUS13  
 AR1 — -XBUS14  
 AP2 — -XBUS15  
 AP1 — -XBUS16  
 AM2 — -XBUS17  
 AM1 — -XBUS18  
 AL2 — -XBUS19  
 AL1 — -XBUS20  
 AK2 — -XBUS21  
 AK1 — -XBUS22  
 AJ2 — -XBUS23  
 AJ1 — -XBUS24  
 AH1 — -XBUS25  
 AH2 — -XBUS26  
 AH1 — -XBUS27  
 AF2 — -XBUS28  
 AF2 — -XBUS29  
 AE1 — -XBUS30  
 AD2 — -XBUS31  
 AD1 — -XBUS32  
 AC1 — -XBUS33  
 BB1 — -XBUS34  
 BA1 — -XBUS35

BE2 — -XADDR.PAR  
 BV7 — -XADDR0  
 BV1 — -XADDR1  
 BU2 — -XADDR2  
 BU1 — -XADDR3  
 BT2 — -XADDR4  
 BS2 — -XADDR5  
 BS1 — -XADDR6  
 BR2 — -XADDR7  
 BR1 — -XADDR8  
 BP2 — -XADDR9  
 BP1 — -XADDR10  
 BW2 — -XADDR11  
 BW1 — -XADDR12  
 BM1 — -XADDR13  
 BL2 — -XADDR14  
 BL1 — -XADDR15  
 BK2 — -XADDR16  
 BK1 — -XADDR17  
 BJ2 — -XADDR18  
 BJ1 — -XADDR19  
 BH2 — -XADDR20  
 BH1 — -XADDR21

CM1 — -XBUS36  
 CL1 — -XBUS37  
 CE1 — -XBUS38  
 CN1 — -XBUS39  
 CC1 — -XBUS40  
 CB1 — -XBUS41

CD2 — -XBUS.RQ  
 CE2 — -XBUS.ACK  
 CE2 — -XBUS.WR  
 CH2 — -XBUS.IGNPAR  
 CJ2 — -XBUS.INIT  
 CR2 — -XBUS.EXTRQ  
 CL2 — -XBUS.BUSY  
 CM2 — -XBUS.SYNC  
 CP2 — -XBUS.INTR  
 CH1 — -XBUS.EXTGRANT.IN  
 CJ1 — -XBUS.EXTGRANT.OUT  
 CK1 — -XBUS.POWER.OK

AC2 --- GND  
 AF1 --- GND  
 AM1 --- GND  
 AN1 --- GND  
 BC2 --- GND  
 BE1 --- GND  
 BF1 --- GND  
 BL1 --- GND  
 CC2 --- GND  
 CF1 --- GND  
 CN1 --- GND  
 CI1 --- GND

OP1 --- +12V  
 OR1 --- +12V  
 OS1 --- +12V

AR2 --- -5V  
 BR2 --- -5V  
 CR2 --- -5V  
 DR2 --- -5V  
 ER2 --- -5V  
 FR2 --- -5V

AA2 --- +5V  
 BA2 --- +5V  
 CA2 --- +5V  
 DA2 --- +5V  
 EA2 --- +5V

EE2 --- XBUS.PAR  
 EF1 --- XBUS0  
 ED2 --- XBUS1  
 ED1 --- XBUS2  
 EC1 --- XBUS3  
 EF1 --- XBUS4  
 EV2 --- XBUS5  
 EV1 --- XBUS6  
 AV1 --- XBUS7  
 AV2 --- XBUS8  
 AU1 --- XBUS9  
 AU2 --- XBUS10  
 AS2 --- XBUS11  
 AS1 --- XBUS12  
 AR2 --- XBUS13  
 AR1 --- XBUS14  
 AP2 --- XBUS15  
 AP1 --- XBUS16  
 AN2 --- XBUS17  
 AN1 --- XBUS18  
 AM2 --- XBUS19  
 AM1 --- XBUS20  
 AL2 --- XBUS21  
 AL1 --- XBUS22  
 AK2 --- XBUS23  
 AK1 --- XBUS24  
 AJ2 --- XBUS25  
 AJ1 --- XBUS26  
 AH2 --- XBUS27  
 AH1 --- XBUS28  
 AE2 --- XBUS29  
 AE1 --- XBUS30  
 AD2 --- XBUS31  
 AD1 --- XBUS32  
 AC1 --- XBUS33  
 AB1 --- XBUS34  
 AA1 --- XBUS35

EE2 --- XADDR.PAR  
 EV2 --- XADDR0  
 EV1 --- XADDR1  
 EU2 --- XADDR2  
 EU1 --- XADDR3  
 EL2 --- XADDR4  
 ES2 --- XADDR5  
 ES1 --- XADDR6  
 ER2 --- XADDR7  
 ER1 --- XADDR8  
 EP2 --- XADDR9  
 EP1 --- XADDR10  
 EN2 --- XADDR11  
 EN1 --- XADDR12  
 EM2 --- XADDR13  
 EM1 --- XADDR14  
 EL2 --- XADDR15  
 EL1 --- XADDR16  
 EK2 --- XADDR17  
 EK1 --- XADDR18  
 EJ2 --- XADDR19  
 EJ1 --- XADDR20  
 EH2 --- XADDR21  
 EH1 --- XADDR22

EW1 --- XBUS36  
 EL1 --- XBUS37  
 EE1 --- XBUS38  
 ED1 --- XBUS39  
 EC1 --- XBUS40  
 EB1 --- XBUS41

ED2 --- XBUS.RQ  
 EE2 --- XBUS.ACK  
 EL2 --- XBUS.WR  
 EH2 --- XBUS.IGNPAR  
 EJ2 --- XBUS.INIT  
 EK2 --- XBUS.EXTRQ  
 EL2 --- XBUS.BUSY  
 EM2 --- XBUS.SYNC  
 EP2 --- XBUS.INTR  
 EH1 --- XBUS.EXTGRANT.IN  
 EJ1 --- XBUS.EXTGRANT.OUT  
 EK1 --- XBUS.POWER.OK

LISP Machine Disk Controller CADRDC:DC UML 10-DEC-80 1753  
 \*\*\*\*\* DIP MAP \*\*\*\*\*

26S10 DCXBUS x	74S260 DCECC xx	74LS273 DCECC x	74LS374 DCECC x	74S163 DCPOSC x	74S240 DCSTS x
F30	E30	D30	C30	B30	A30
26S10 DCXBUS x	26S10 DCXBUS x	74LS273 DCECC x	74LS374 DCECC x	74S163 DCPOSC x	74S133 DCPOSC x
F29	E29	D29	C29	B29	A29
26S10 DCXBUS x	26S10 DCXBUS x	74LS273 DCECC x	74S260 DCECC xx	74S163 DCPOSC x	74LS00 DCCMD xxx
F28	E28	D28	C28	B28	A28
26S10 DCXBUS x	74LS86 DCECC xxxx	74LS273 DCECC x	74S133 DCECC x	74S163 DCPOSC x	74LS153 DCHDCM x
F27	E27	D27	C27	B27	A27
26S10 DCXBUS x	74LS374 DCCCW x	74LS374 DCCLP x	74S260 DCPOSC xx	74S133 DCPOSC x	74LS153 DCHDCM x
F26	E26	D26	C26	B26	A26
26S10 DCXBUS x	74LS374 DCCCW x	74LS569 DCCLP x	74LS374 DCCLP x	74LS244 DCPOSC x	74LS153 DCHDCM x
F25	E25	D25	C25	B25	A25
26S10 DCXBSA x	26S10 DCXBSA x	74LS273 DCSTS x	74LS374 DCCLP x	74LS244 DCPOSC x	74LS153 DCHDCM x
F24	E24	D24	C24	B24	A24
26S10 DCXBSA x	26S10 DCXBSA x	74LS569 DCCLP x	74LS04 DCCLP xxxxxx	74LS374 DCCLP x	25LS2536 DCHDCM x
F23	E23	D23	C23	B23	A23
26S10 DCXBSA x	74LS569 DCCCW x	74LS569 DCCLP x	25LS2521 DCHDCM x	74LS193 DCDA x	----- -----
F22	E22	D22	C22	B22	A22
26S10 DCXBSA x	74LS569 DCCCW x	74LS569 DCCLP x	74LS175 DCCWD x	74LS193 DCDA x	74LS193 DCDA x
F21	E21	D21	C21	B21	A21
26S10 DCPAR x	74LS74 DCCCW xx	9S42 DCUC xx	TD250 DCCHAN x	74LS244 DCDA x	74LS193 DCDA x
F20	E20	D20	C20	B20	A20



LISP Machine Disk Controller CADRDC:DC UML 10-DEC-80 1754  
 \*\*\*\*\* DIP MAP \*\*\*\*\*

26S10 DCCHAN x	TD100 DCCHAN x	74S04 DCXBSA xxxxxx	74LS10 DCCMD xxx	74LS244 DCDA x	74LS193 DCDA x
F19	E19	D19	C19	B19	A19
26S10 DCCHAN x	74S11 DCCHAN xxx	74LS00 DCUC xxxxx	74S51 DCCLK xx	74LS244 DCDA x	74LS193 DCDA x
F18	E18	D18	C18	B18	A18
9S42 DCCHAN xx	74S74 DCCHAN xx	74S08 DCUC xxxxx	74S37 DCCLK xxxxx	74LS244 DCDA x	74LS193 DCDA x
F17	E17	D17	C17	B17	A17
74LS74 DCCLK xx	74S02 DCREG xxxxx	74LS08 DCUC xxxxx	74LS32 DCCMD xxxxx	74LS02 DCCLP xxxxx	74LS86 DCSH xxxxx
F16	E16	D16	C16	B16	A16
93S48 DCPAR x	74S133 DCREG x	74LS74 DCCLK xx	74LS08 DCRBUF xxxxx	74LS21 DCBUSY xo	74LS244 DCSTS x
F15	E15	D15	C15	B15	A15
93S48 DCPAR x	25LS2521 DCREG x	74LS08 DCSH xxxxx	74LS74 DCCLK xx	74S74 DCBUSY xx	74LS244 DCSTS x
F14	E14	D14	C14	B14	A14
93S48 DCPAR x	TD250 DCREG x	74LS138 DCUC x	74S74 DCCLK xx	74S260 DCBUSY xx	74LS244 DCSTS x
F13	E13	D13	C13	B13	A13
93S48 DCPAR x	74S138 DCREG x	74LS153 DCUC x	74LS273 DCSTS x	74LS279 DCSTS x	74LS244 DCSTS x
F12	E12	D12	C12	B12	A12
93S48 DCPAR x	74LS02 DCREG xxxxx	74LS86 DCPAR xxxxx	25LS2521 DCDCM x	74LS32 DCSH xxxxx	74S151 DCUC x
F11	E11	D11	C11	B11	A11
74LS374 DCRBUF x	67401 DCRBUF x	74S299 DCSH x	74LS273 DCCMD x	74S74 DCSH xx	75107 DCRID xx
F10	E10	D10	C10	B10	A10
74LS374 DCRBUF x	67401 DCRBUF x	74LS11 DCCCW xxx	74LS244 DCDBUS x	26S02 DCTMOT xx	DUMMY DCRID x
F09	E09	D09	C09	B09	A09

LISP Machine Disk Controller

CADRDC;DC UML

10-DEC-80 1758

\*\*\*\*\* DIP MAP \*\*\*\*\*

74LS374 DCRBUF x	74LS175 DCRBUF x	74LS273 DCUI x	74LS244 DCDBUS x	74LS569 DCTRID x	75110 DCTRID x
F08	E08	D08	C08	B08	A08
74LS374 DCRBUF x	TD100 DCRBUF x	74LS273 DCUI x	74LS244 DCDBUS x	74LS569 DCTRID x	74LS14 DCTRID xxxxxo
F07	E07	D07	C07	B07	A07
74LS374 DCWBUF x	74LS21 DCRBUF xx	74LS273 DCUI x	74LS157 DCDBUS x	74LS74 DCBUSY xo	STP330-1 DCTRSG x
F06	E06	D06	C06	B06	A06
74LS374 DCWBUF x	74LS08 DCSH xxxx	74S472 DCUI x	74LS04 DCDBUS xxxxxx	75452 DCTRSG xx	DUMMY DCTRSG x
F05	E05	D05	C05	B05	A05
74LS374 DCWBUF x	74LS00 DCSH xxox	74S472 DCUI x	DUMMY DCTMOT x	74LS124 DCTMOT xx	74LS14 DCTRSG xxxxxx
F04	E04	D04	C04	B04	A04
74LS374 DCWBUF x	74LS175 DCWBUF x	74S472 DCUI x	74 393 DCTMOT xx	75452 DCTRSG xx	DUMMY DCTRSG x
F03	E03	D03	C03	B03	A03
67401 DCWBUF x	74LS74 DCRBUF xx	----- -----	74LS569 DCUC x	SIP100-8 DCTRSG x	75452 DCTRSG xx
F02	E02	D02	C02	B02	A02
67401 DCWBUF x	TD100 DCWBUF x	74S299 DCSH x	74LS569 DCUC x	75452 DCTRSG xx	STP100-8 DCTRSG x
F01	E01	D01	C01	B01	A01

LISP Machine Disk Controller CADDRC:DC UML 10-DEC-80 1759
\*\*\*\*\* EDGE CONNECTIONS Flags: (# Output, @ Terminator, ---- Dedicated ground, ++++ Dedicated power) \*\*\*\*\*

Table with 4 columns labeled -A-, -B-, -C-, and -D-. It lists various bus connections (e.g., XBUS35, XBUS34, XBUS33) and their corresponding signals (e.g., +5.0V, GND, XADDR, XBUS, XINIT, XPOWER, XINTR, XCLK, XBLOCK). The table is organized into rows, each representing a specific connection point and its associated signal definitions.

LISP Machine Disk Controller CADRDC;DC UML 10-DEC-80 1759  
 \*\*\*\*\* EDGE CONNECTIONS Flags: (# Output, @ Terminator, ---- Dedicated ground, ++++ Dedicated power) \*\*\*\*\*

-E-		-F-		-J01-		-J02-	
A1	A2 +5.0V+++++	A1	A2 +5.0V+++++	01 TRIDENT.CYL.TAG/	# 01	02 TRIDENT.CONTROL.TAG/	# 02
B1	B2 -5.0V	B1	B2 -5.0V	03 TRIDENT.TER.IN/	03	04 GND	@ 04
C1	C2 GND-----	@ C1	@ C2 GND-----	05 GND	@ 05	06 GND	@ 06
D1	D2 BLOCK.CTR2	# D1	# D2	07 GND	07	08 GND	08
E1	E2 BLOCK.CTR3	# E1	# E2	09 GND	@ 09	10 GND	@ 10
F1 GND	F2 BLOCK.CTR4	@ F1 GND	# F2	11 GND	@ 11	12 GND	@ 12
H1	H2 BLOCK.CTR5	# H1	# H2	13 GND	@ 13	14 GND	@ 14
J1	J2 BLOCK.CTR6	# J1	# J2	15 GND	@ 15	16 GND	@ 16
K1	K2 BLOCK.CTR7	# K1	# K2	17 +5.0V	17	18 +5.0V	18
L1	L2 XBI28	# L1	# L2	19 TRIDENT.ADDR.MK.DET/	19	20 TRIDENT.SECTOR/	20
M1	M2 XBI29	# M1	# M2	21	21	22	22
N1 GND	N2 XBI30	@ N1 GND	# N2	23	@ 23	24	24
P1	P2 UNIT0	P1	P2	25	25	26 TRIDENT.HEAD.TAG/-----	# 26 -----
R1	R2 UNIT1	R1	R2	27 TRIDENT.BUS0/-----	# 27 -----	28 TRIDENT.BUS1/-----	# 28 -----
S1	S2 UNIT2	S1	S2	29 TRIDENT.BUS2/-----	# 29 -----	30 TRIDENT.BUS3/-----	# 30 -----
T1 GND	T2 -CYLINDER TAG H	@ T1 GND	# T2	31 TRIDENT.BUS4/-----	# 31 -----	32 TRIDENT.BUS5/-----	# 32 -----
U1	U2 -HEAD TAG H	# U1	# U2	33 TRIDENT.BUS6/-----	# 33 -----	34 TRIDENT.BUS7/-----	# 34 -----
V1	V2	V1	V2	35 TRIDENT.BUS8/-----	# 35 -----	36 TRIDENT.BUS9/-----	# 36 -----
				37 TRIDENT.SPARE/-----	37	38 TRIDENT.SEEK.INC/-----	@ 38 -----
				39 TRIDENT.ON.LINE/-----	@ 39 -----	40 TRIDENT.DEVICE.CHECK/---	@ 40 -----
				41 TRIDENT.READ.ONLY/-----	@ 41 -----	42 TRIDENT.READY/-----	@ 42 -----
				43 TRIDENT.INDEX/-----	43	44 TRIDENT.OFFSET/-----	44
				45 TRIDENT.END.OF.CYL/----	45	46	46
				47	47	48	48
				49	49	50	50

LISP Machine Disk Controller CADRDC;DC UML 10-DEC-80 1759  
\*\*\*\*\* EDGE CONNECTIONS Flags: (# Output, @ Terminator, ---- Dedicated ground, ++++ Dedicated power) \*\*\*\*\*

-J03-

-J04-

-J05-

-J06-

01 GND	@ 01	01 HI1	@ 01
02 GND	@ 02	02 AD14	@ 02
03 GND	@ 03	03 HI1	@ 03
04 GND	@ 04	04 AD13	@ 04
05 GND	@ 05	05 HI1	@ 05
06 GND	@ 06	06 AD6	@ 06
07 GND	@ 07	07 HI1	@ 07
08 GND	@ 08	08 AD5	@ 08
09 GND	@ 09	09 HI1	@ 09
10 +5.0V	10	10 AD4	10
11	11	11 HI1	@ 11
12	12	12 AD3	12
13	13	13 HI1	@ 13
14	14	14 AD2	14
15	15	15 HI1	@ 15
16	16	16 -TIMEOUT ENB H	16
17	17	17	17
18	18	18	18
19	19	19	19
20	20	20	20
21 TRIDENT.O.CLOCK.M----	21 -----	21	21
22 TRIDENT.O.CLOCK.P----	22 -----	22	22
23 TRIDENT.O.DATA.M-----#	# 23 -----	23	23
24 TRIDENT.O.DATA.P-----#	# 24 -----	24	24
25 TRIDENT.O.SELECT/-----#	# 25 -----	25	25
26 TRIDENT.O.SEQUENCE/-----#	# 26 -----	26	26
27 TRIDENT.O.SELECTED/-----@	@ 27 -----	27 GND-----	@ 27 -----
28 TRIDENT.O.ATTENTION/-----@	@ 28 -----	28	28
29 TRIDENT.O.COMPSECIDX/-----@	@ 29 -----	29 GND-----	@ 29 -----
30 +5.0V-----	30 -----	30	30 -----
31 -----	31 -----	31 GND-----	@ 31 -----
32 -----	32 -----	32	32 -----
33 -----	33 -----	33 GND-----	@ 33 -----
34 -----	34 -----	34	34 -----
35 -----	35 -----	35 GND-----	@ 35 -----
36 -----	36 -----	36	36 -----
37 -----	37 -----	37 GND-----	@ 37 -----
38 -----	38 -----	38	38 -----
39 -----	39 -----	39 GND-----	@ 39 -----
40 -----	40 -----	40	40 -----
		41 GND-----	@ 41 -----
		42	42 -----
		43	43 -----
		44	44 -----
		45	45 -----
		46	46 -----
		47	47 -----
		48	48 -----
		49	49 -----
		50	50 -----

LISP Machine Disk Controller CADRDC:DC UML 10-DEC-80 1800  
\*\*\*\*\* EDGE CONNECTIONS Flags: (# Output, @ Terminator, ---- Dedicated ground, ++++ Dedicated power) \*\*\*\*\*

-J07-

-J08-

-J09-

-J10-

01	01	01	01
02	02	02	02
03	03	03	03
04	04	04	04
05	05	05	05
06	06	06	06
07	07	07	07
08	08	08	08
09	09	09	09
10	10	10	10
11	11	11	11
12	12	12	12
13	13	13	13
14	14	14	14
15	15	15	15
16	16	16	16
17	17	17	17
18	18	18	18
19	19	19	19
20	20	20	20
21	21	21	21
22	22	22	22
23	23	23	23
24	24	24	24
25	25	25	25
26	26	26	26
27	27	27	27
28	28	28	28
29	29	29	29
30	30	30	30
31	31	31	31
32	32	32	32
33	33	33	33
34	34	34	34
35	35	35	35
36	36	36	36
37	37	37	37
38	38	38	38
39	39	39	39
40	40	40	40
		41	41
		42	42
		43	43
		44	44
		45	45
		46	46
		47	47
		48	48
		49	49
		50	50



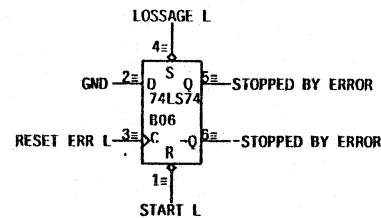
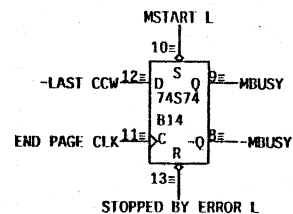
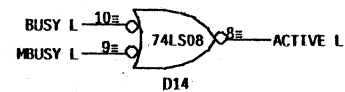
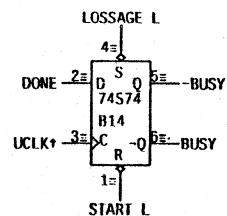
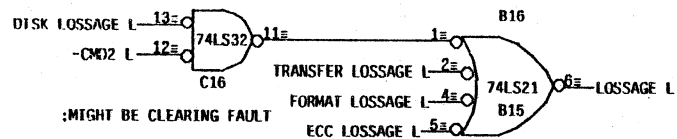
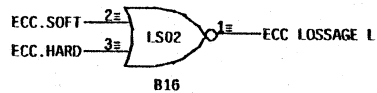
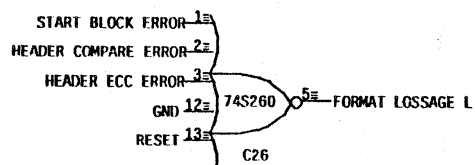
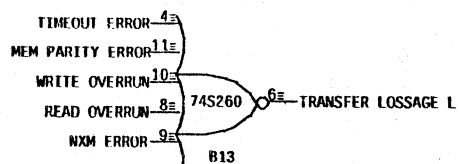
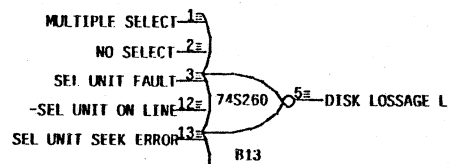



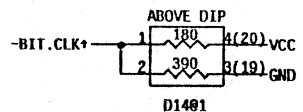
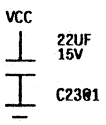
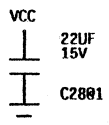
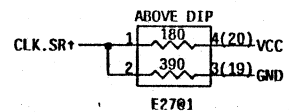
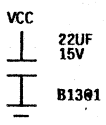
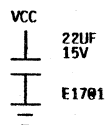
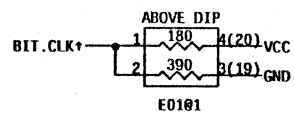
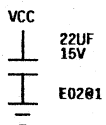
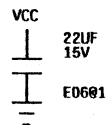

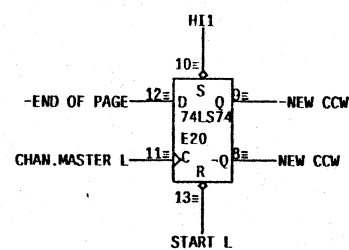
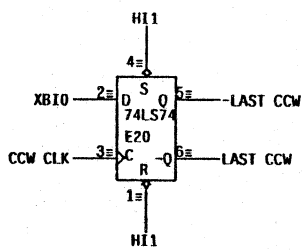
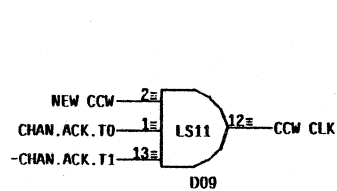
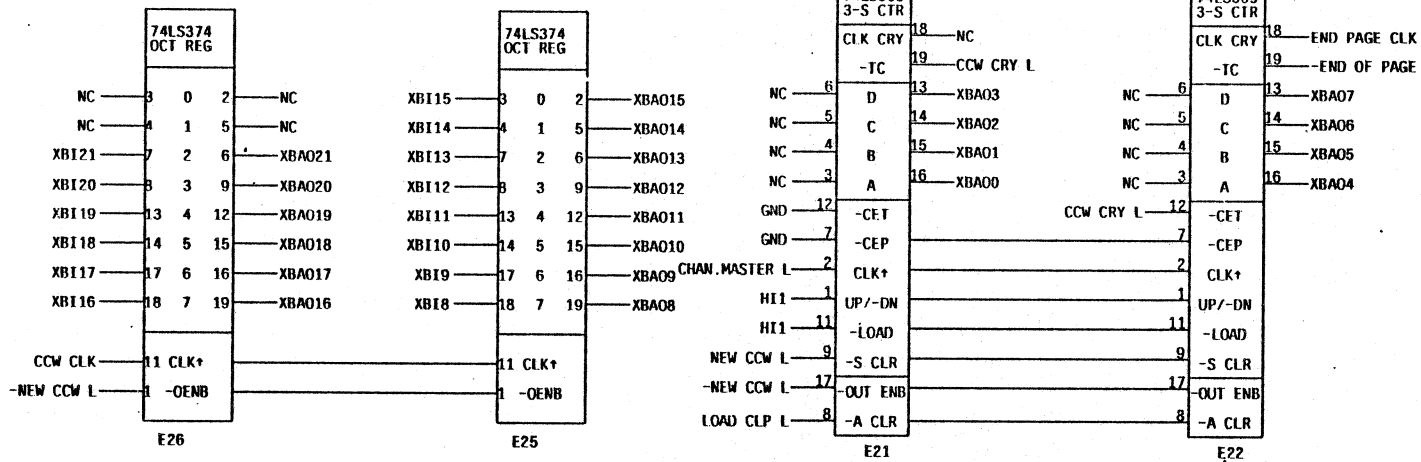

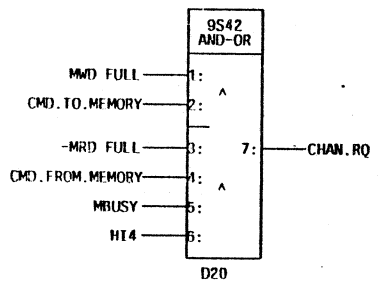
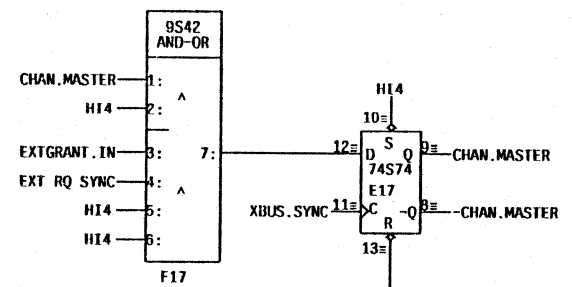
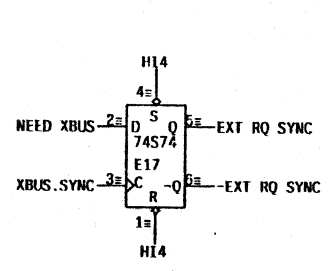
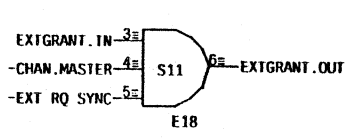
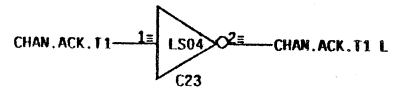
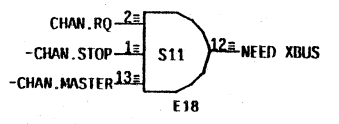
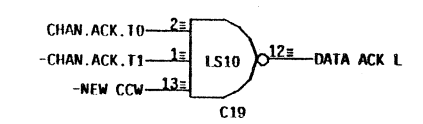

:DELAY FOR OUTPUT PARITY COMPUTATION  
:AND FOR ADDRESS TO SETTLE

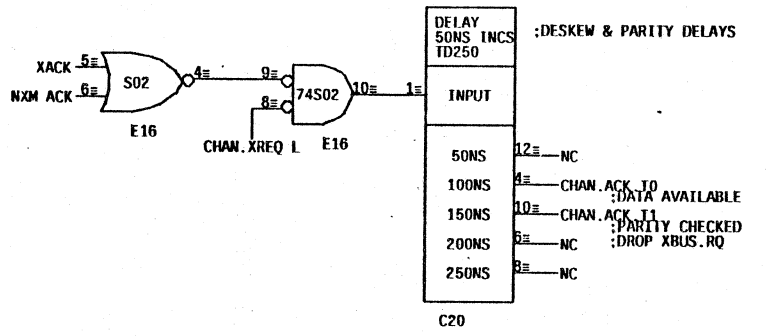
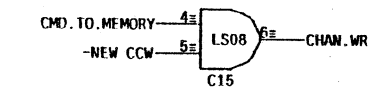
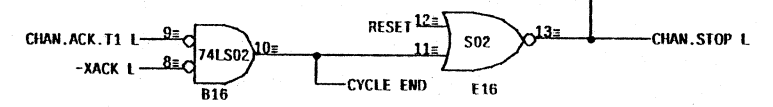
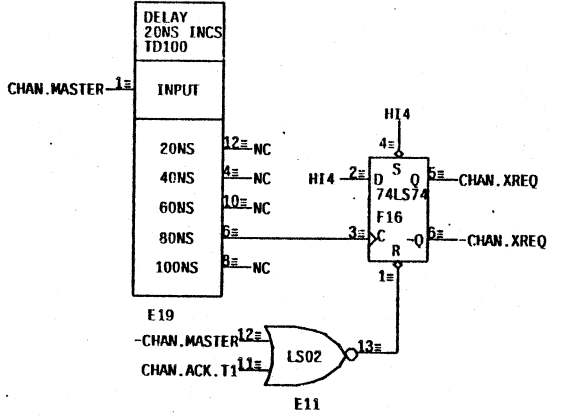

**TIMING**

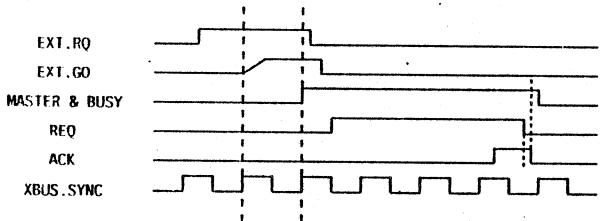

**LOGIC IN BUS CONTROLLER**

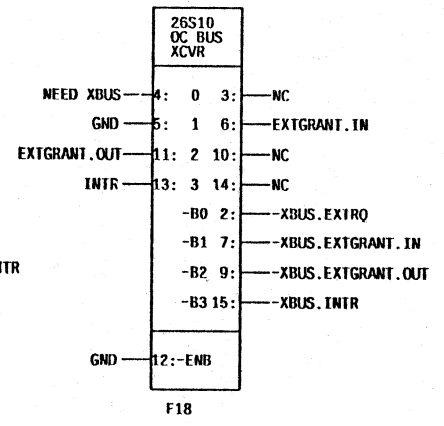
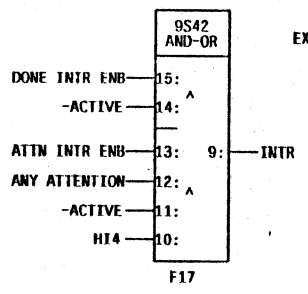
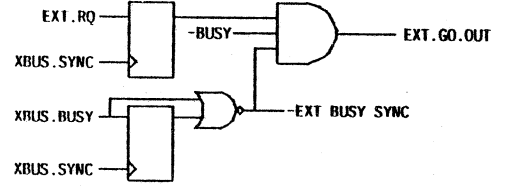

: -XBUS.EXTGRANT.IN terminated  
: on DC1MOT or MKPANEL

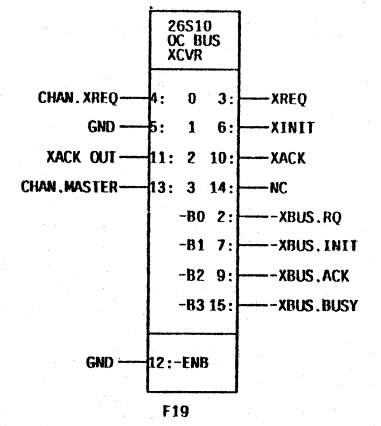

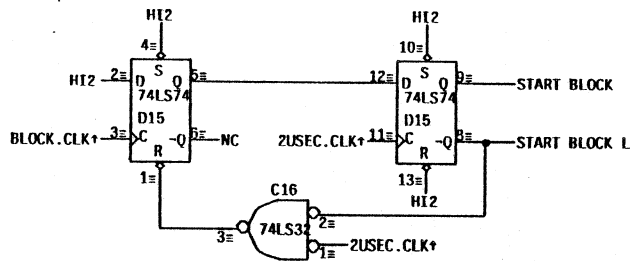
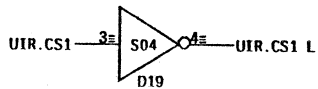
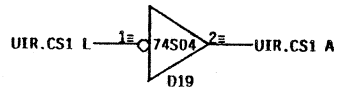
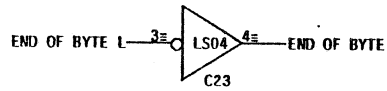
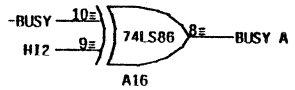
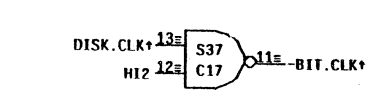

: SYNCHRONIZE START.BLOCK

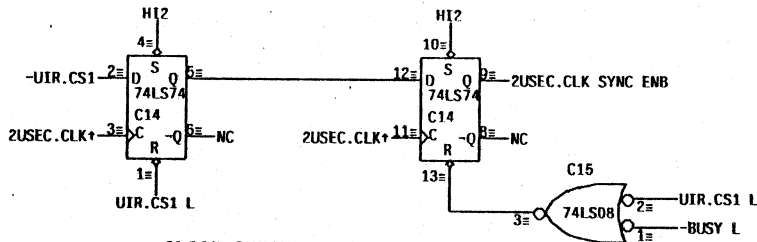
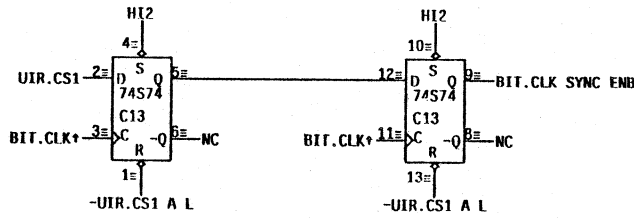

: CLOCK SYNCHRONIZERS

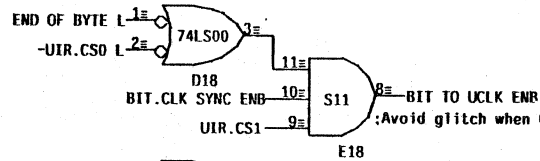

:NOTE- UCLK+ can clock an extra time when stopping due to error

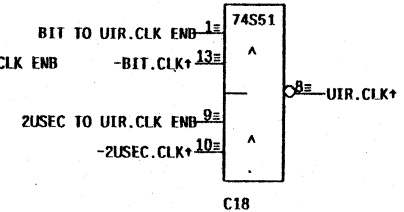
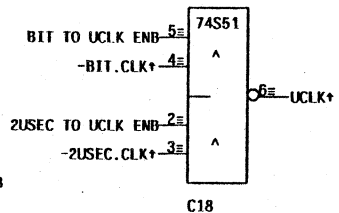
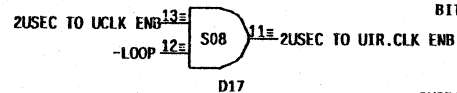
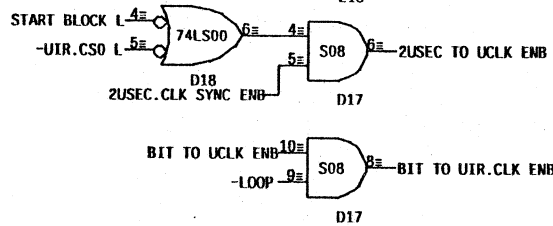

: OUTPUT CLOCKS

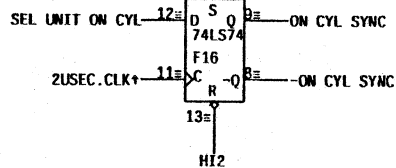

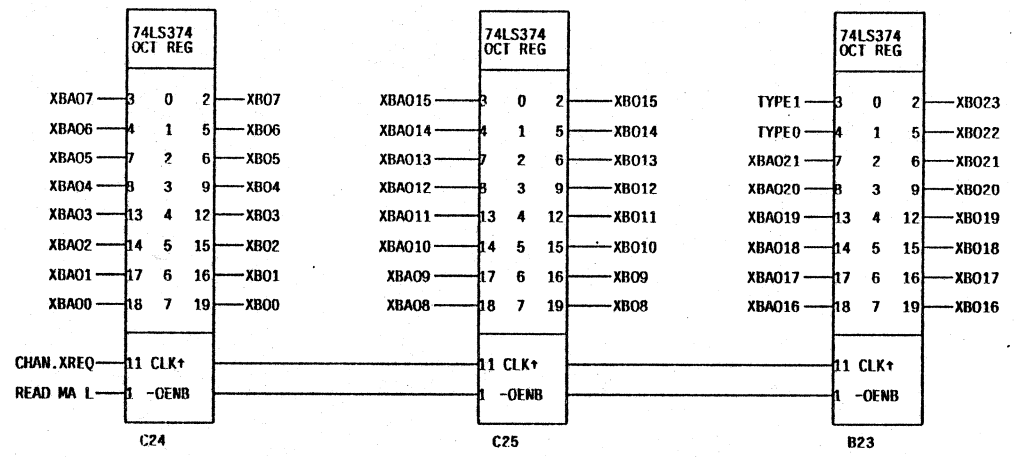
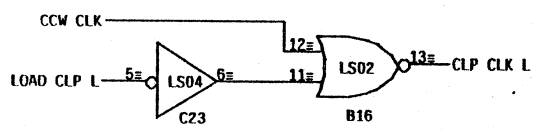
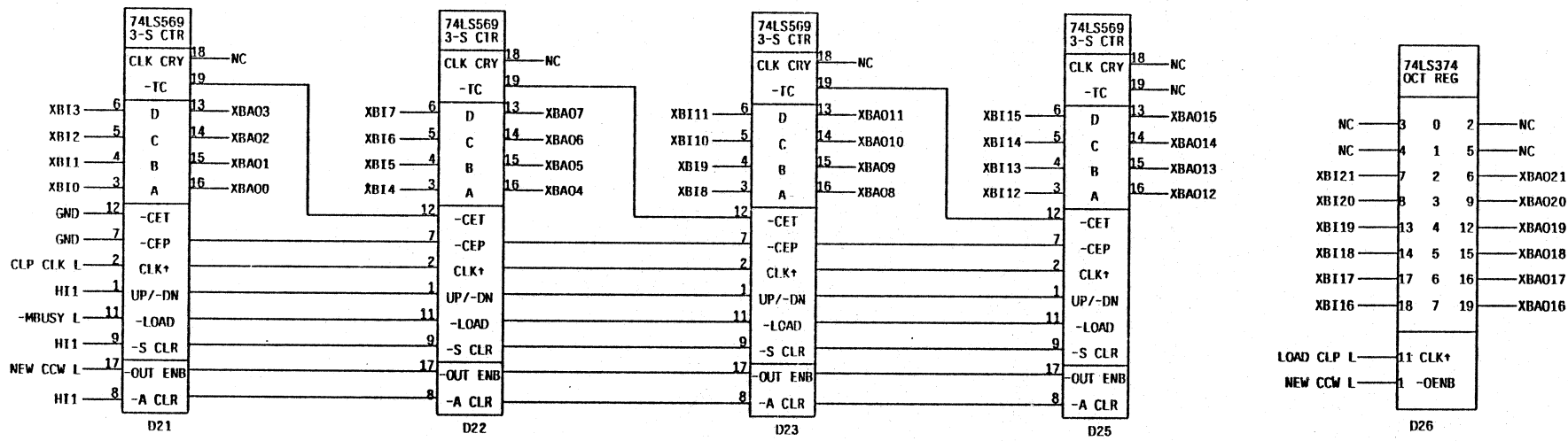

CMD	OPERATION
00	READ
10	READ COMPARE
11	WRITE
02	READ ALL
13	WRITE ALL
04	SEEK
05	AT EASE
1005	RECALIBRATE
405	FAULT CLEAR
06	OFFSET CLEAR
16	STOP, RESET

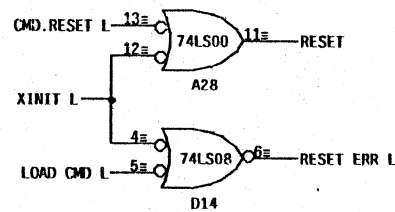
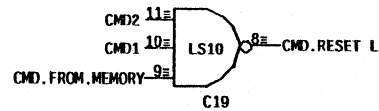
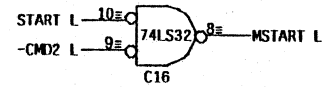
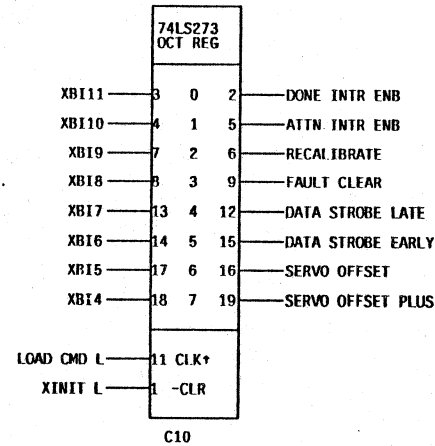
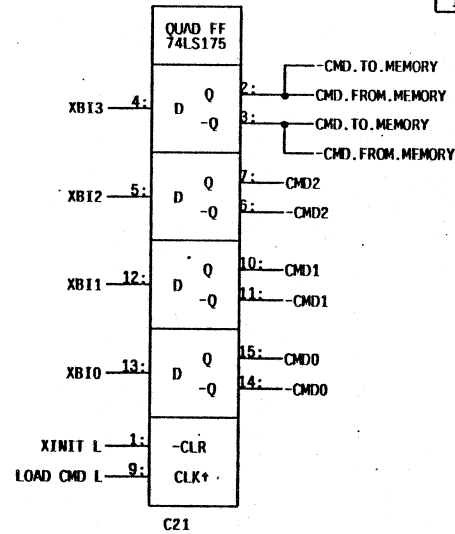



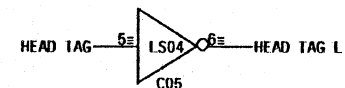
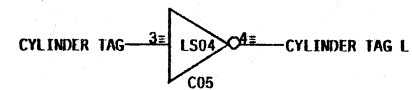
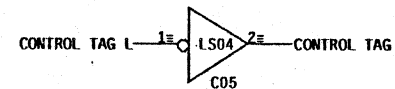
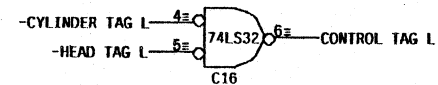
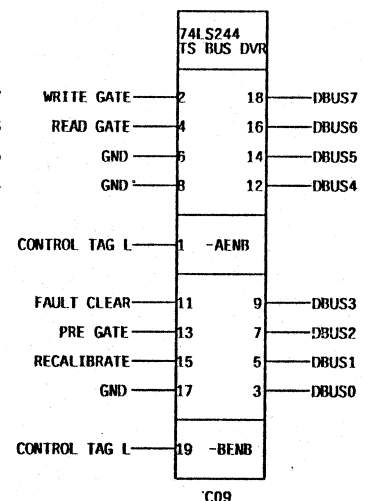
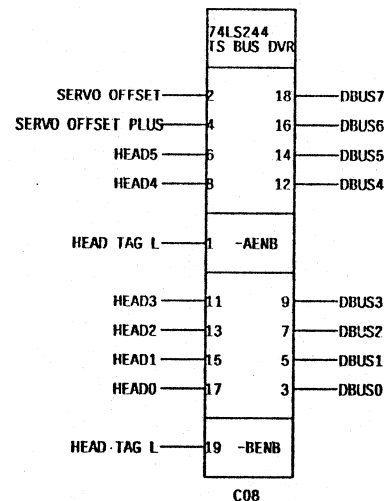
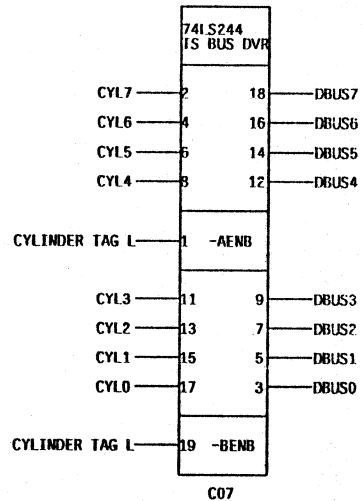
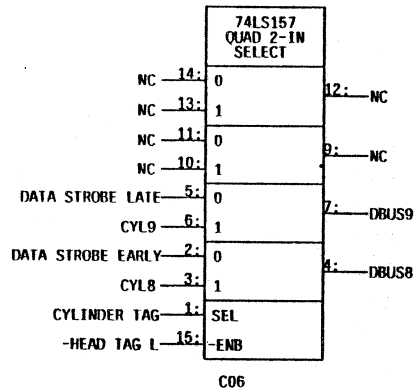



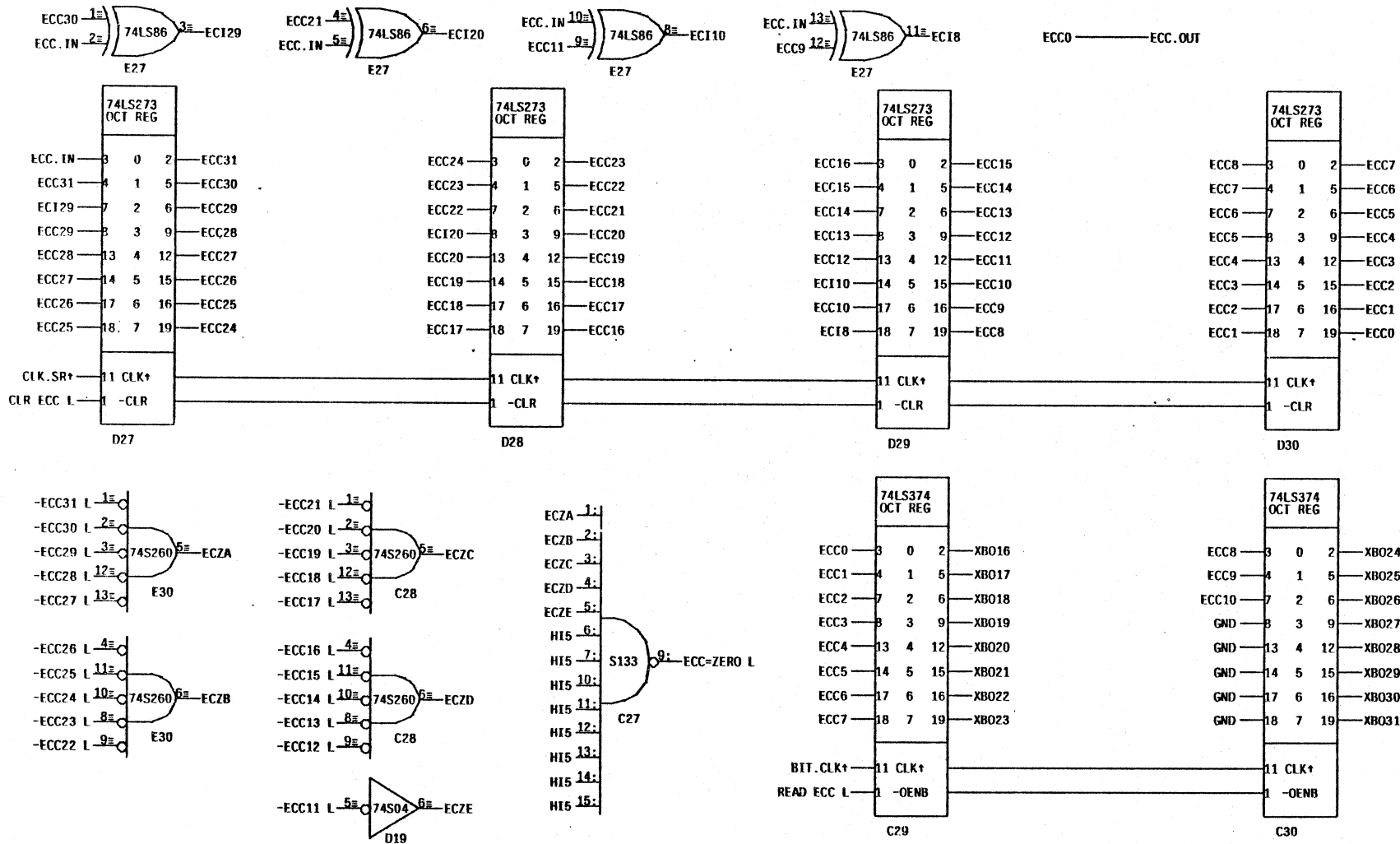

GROUNDS

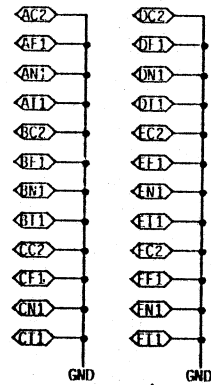

JUMPERS FOR 1-BOARD VERSION:

DE2 - DF2 - DH2  
 DN1 - DM2  
 ET1 - EP2 - ER2 - ES2

OMITTED DIPS IN 2-BOARD VERSION:

A7 A8 A9  
 A10 B7 B8

BE CERTAIN TO EDIT THE  
 RAY FILE FOR UNDEDICATED  
 GROUND PINS ON J1, J3

TO DISK MUX BOARD

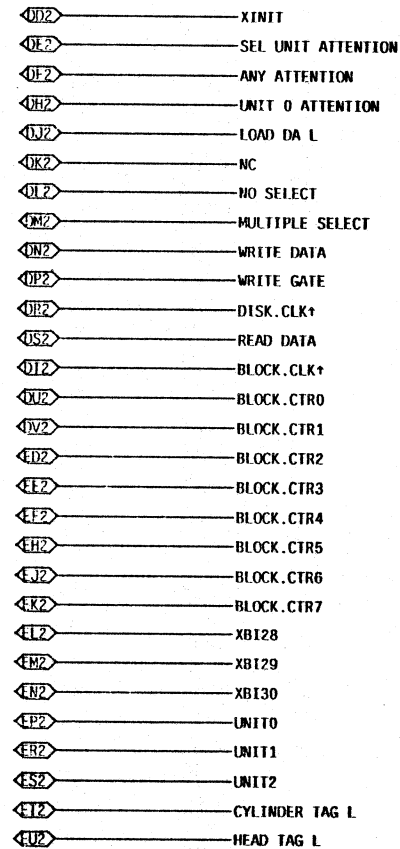

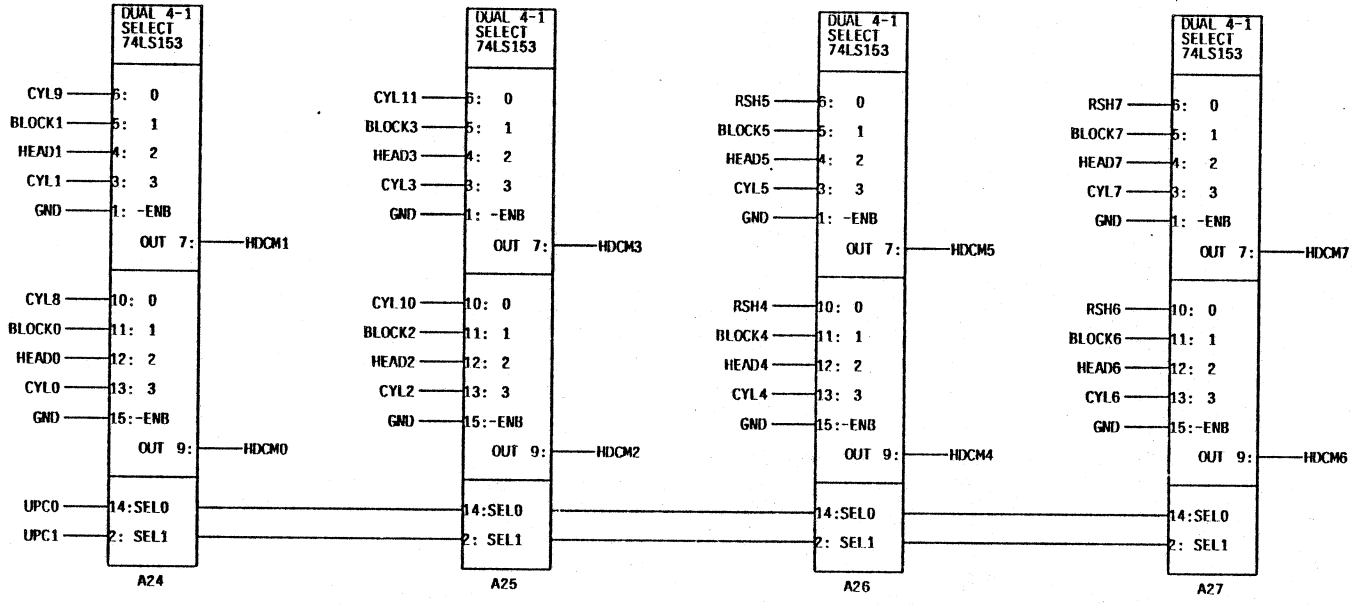
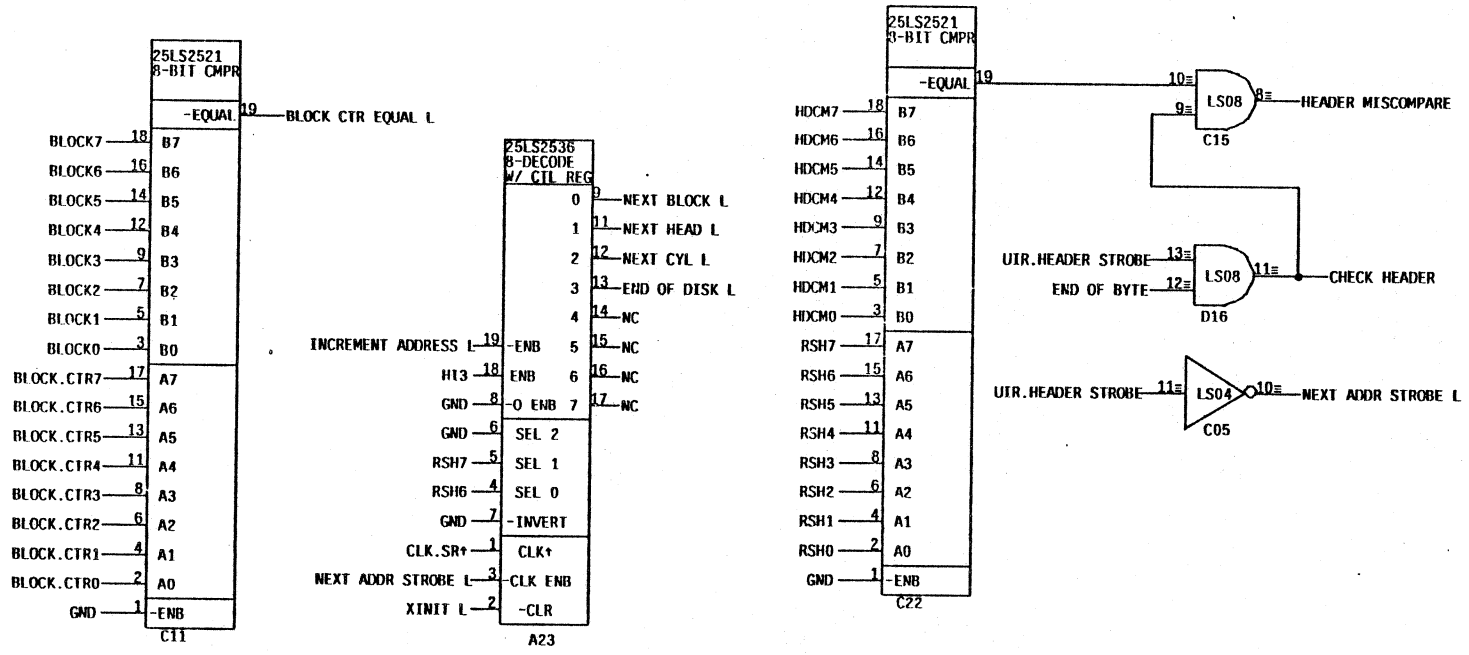

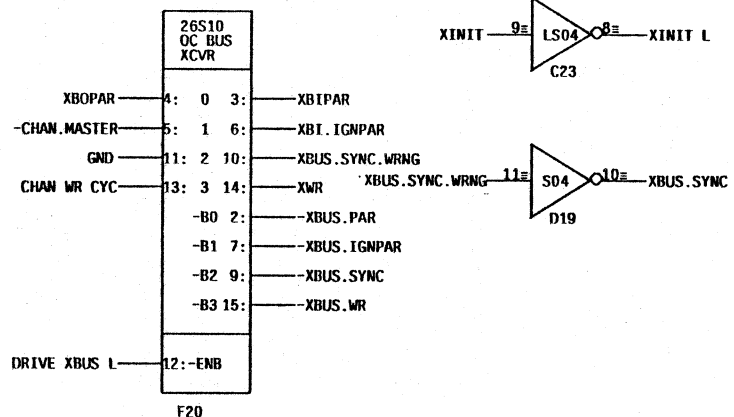
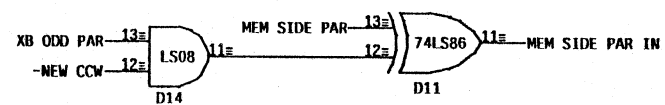
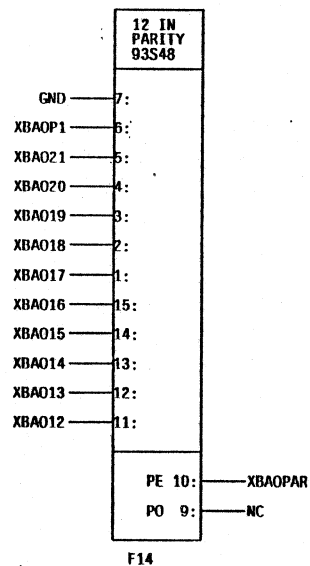
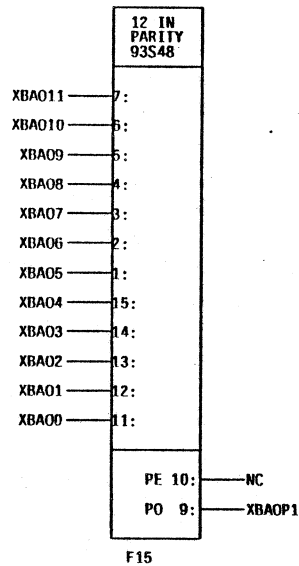
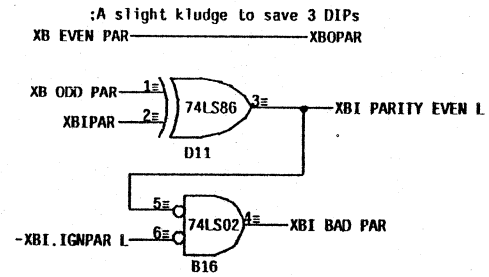
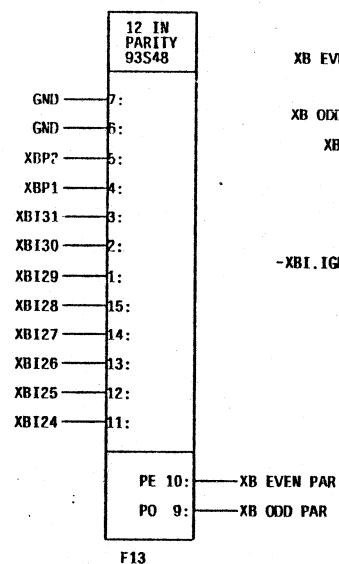
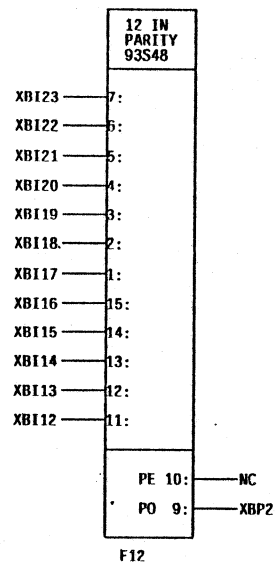
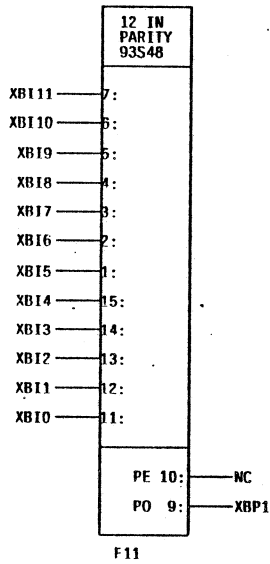

:WHEN READING, HAS ONE LESS THAN THE NUMBER OF  
 :VALID BITS ALREADY CLOCKED IN.  
 :WHEN WRITING, HAS THE NUMBER OF  
 :BITS ALREADY CLOCKED OUT.

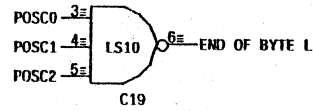

:NOTE SYNCHRONOUS CLEAR

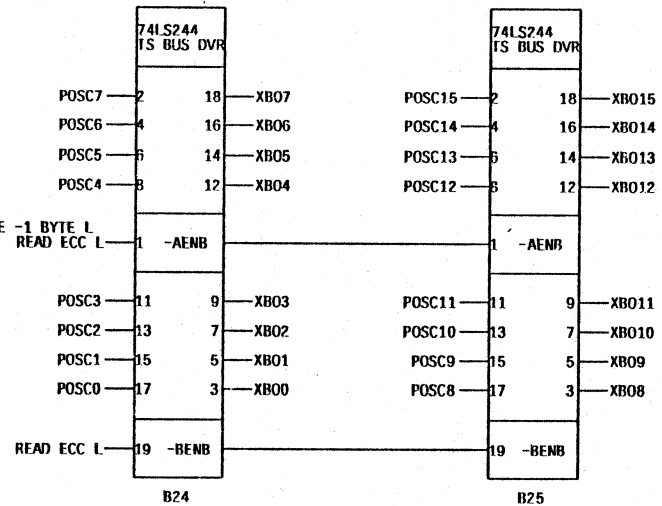
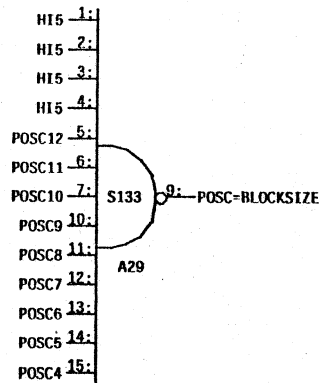
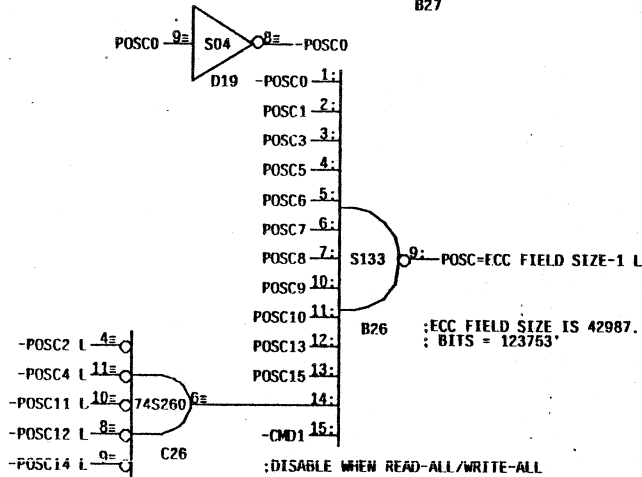
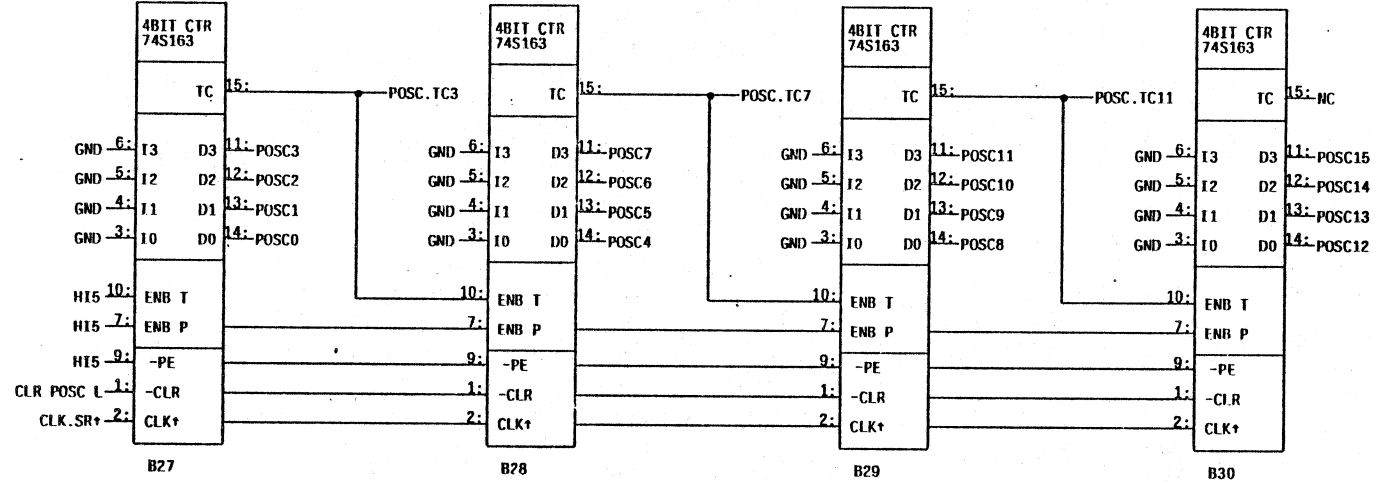

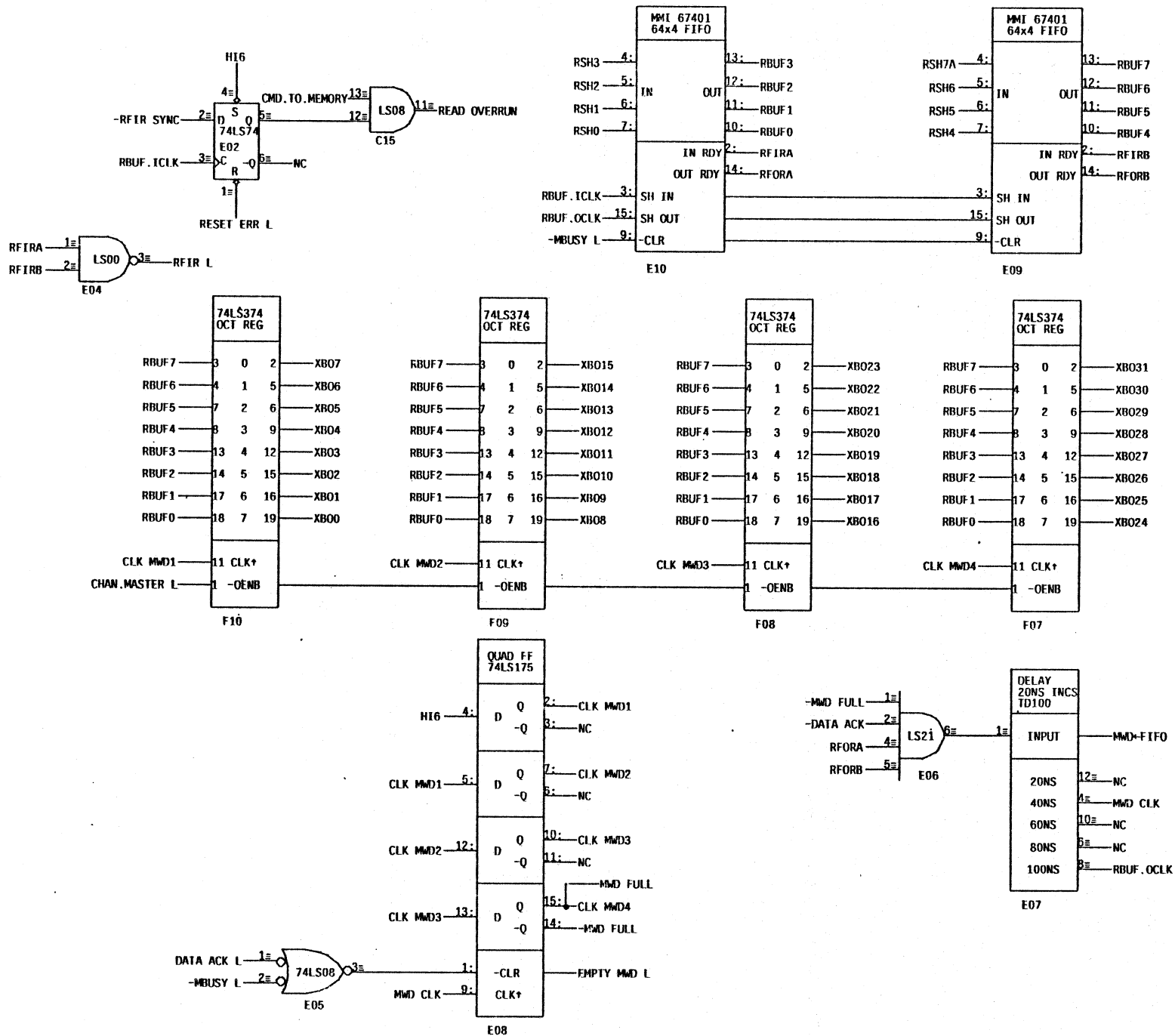



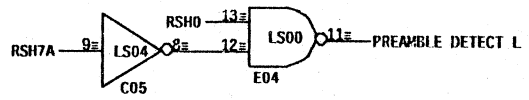
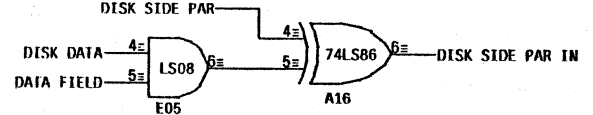
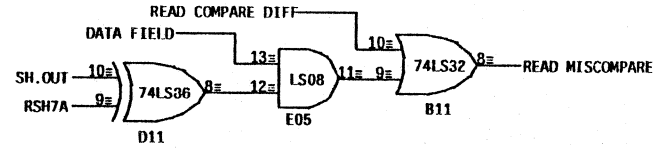
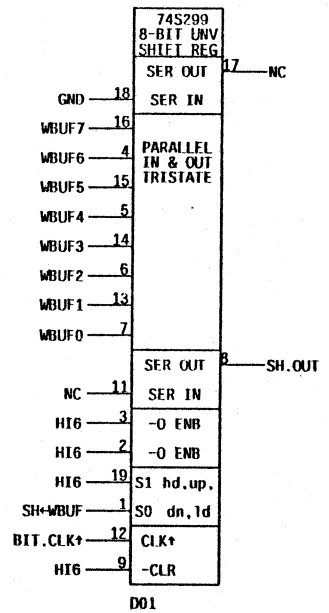
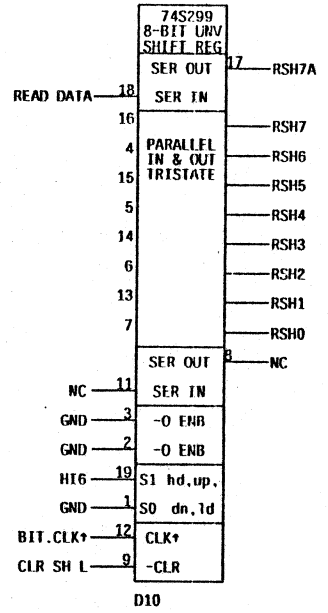
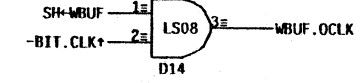
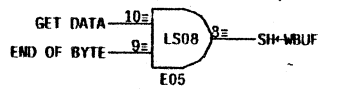
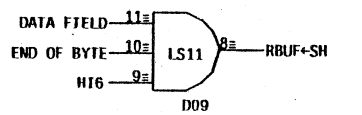
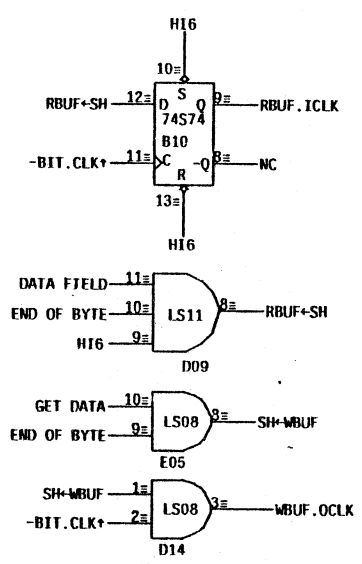



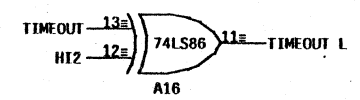
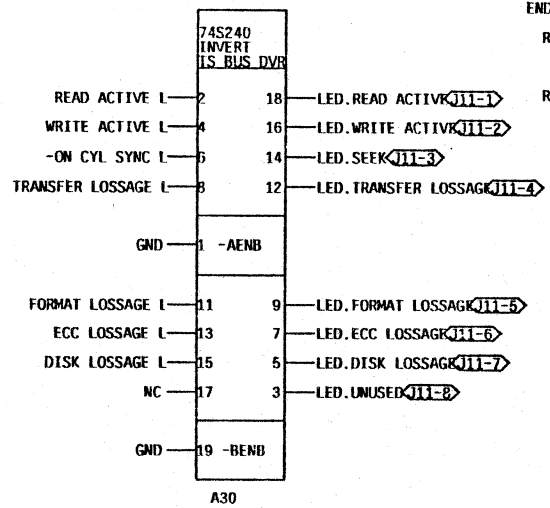
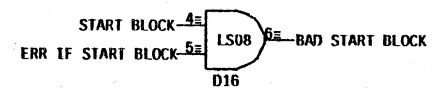
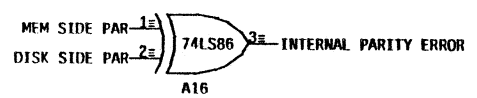
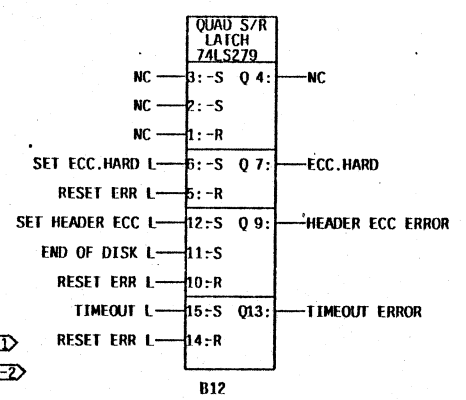
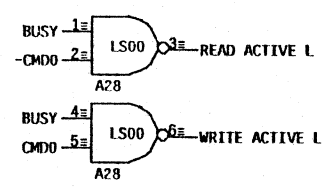
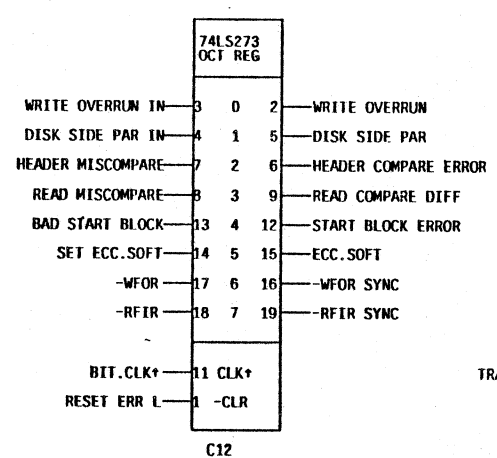
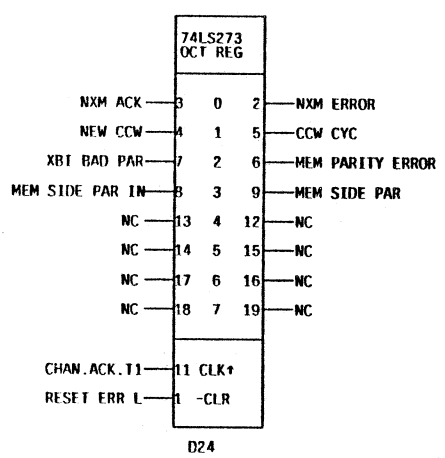
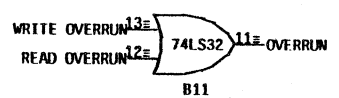
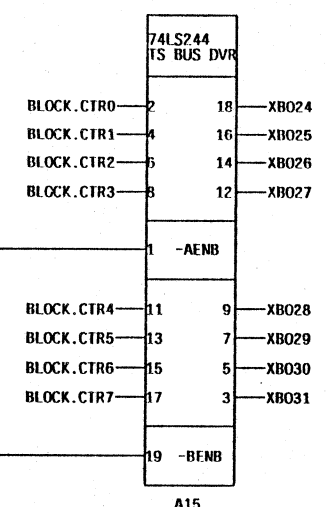
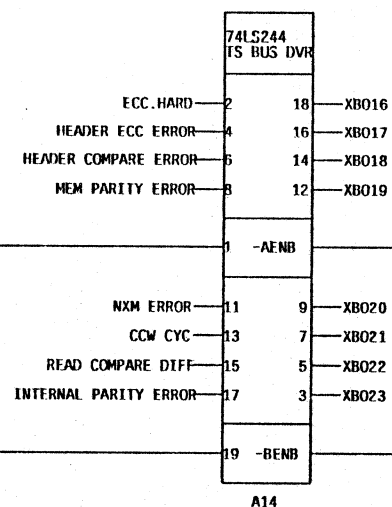
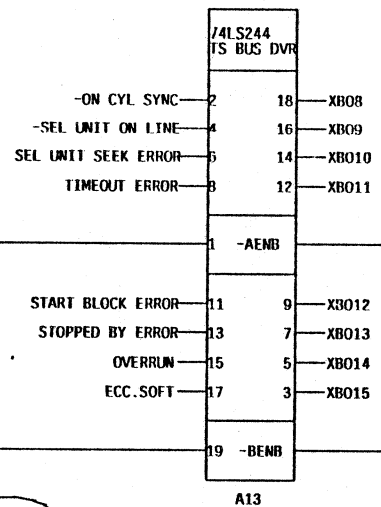
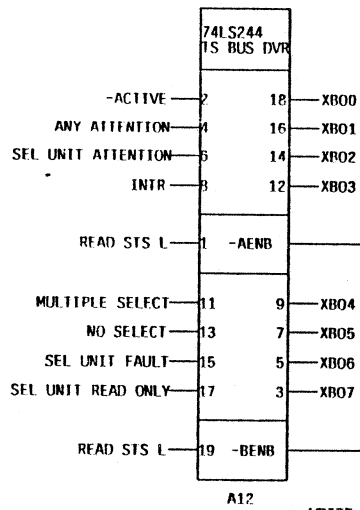

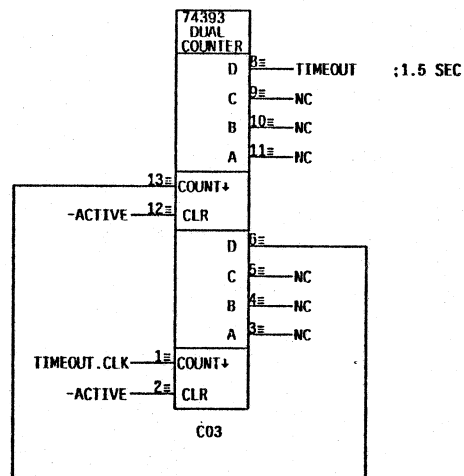
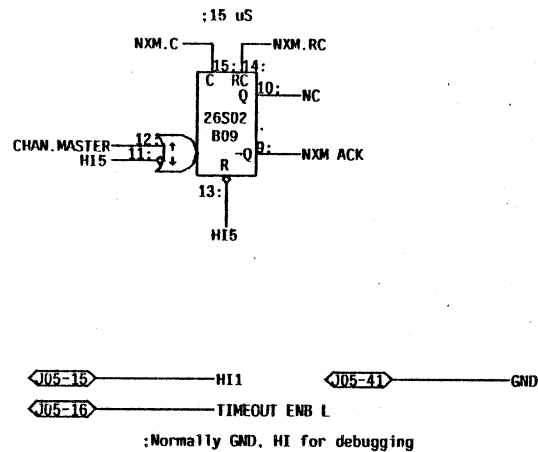
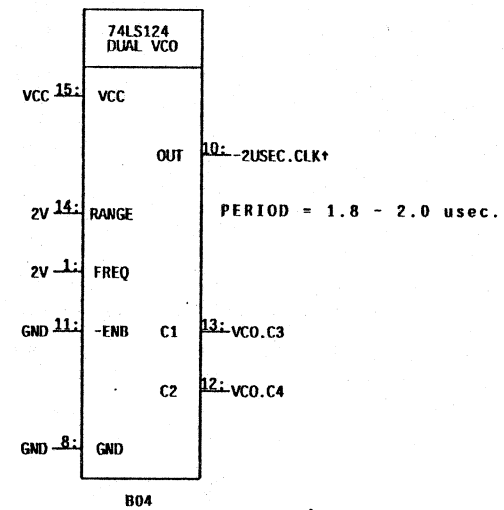
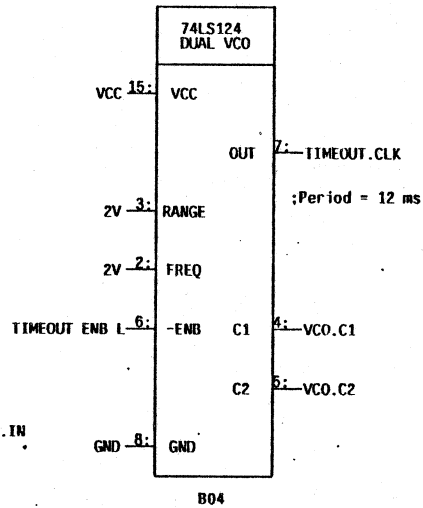
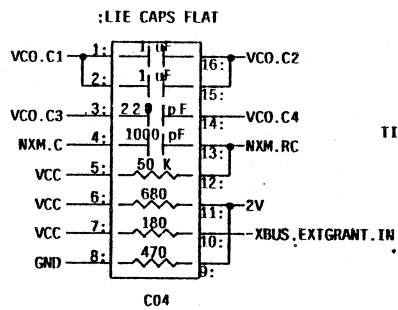

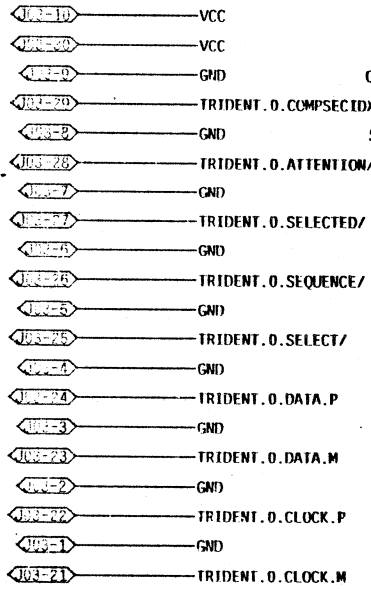

:J3. remove dedicated grounds 21-30  
:Delete pins 11 and 31

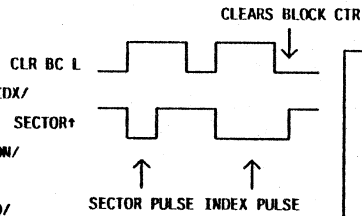

:Set sector length jumpers  
:drive to 1410 (octal)  
:which is 1164. bytes.

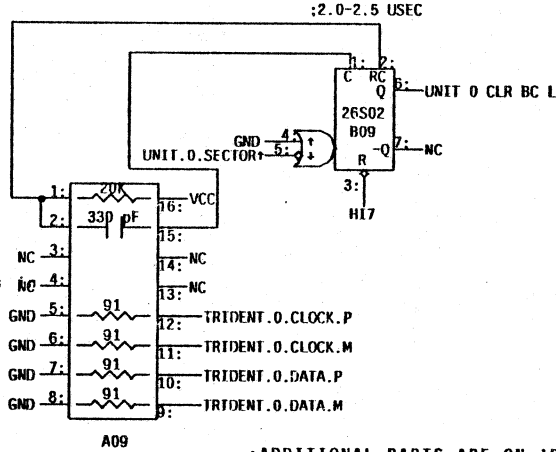

:ADDITIONAL PARTS ARE ON 'DCTRSG'

GND TYPE1  
GND TYPED  
:Trident is type 0

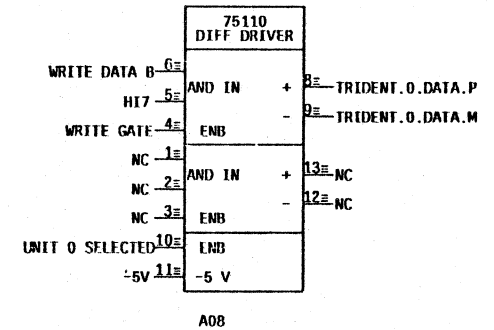
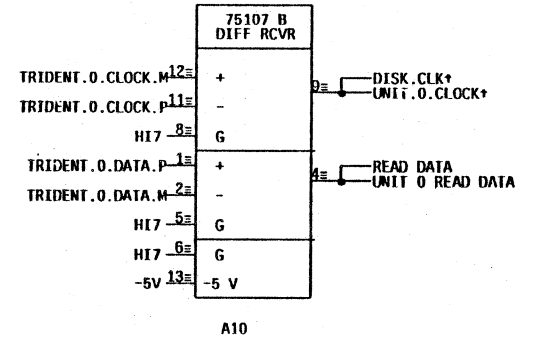
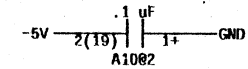
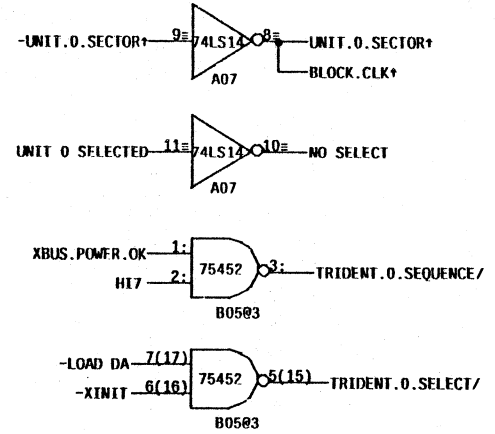
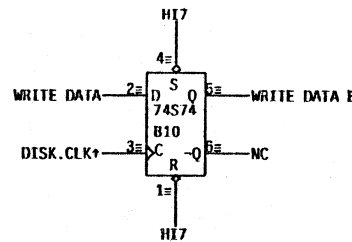
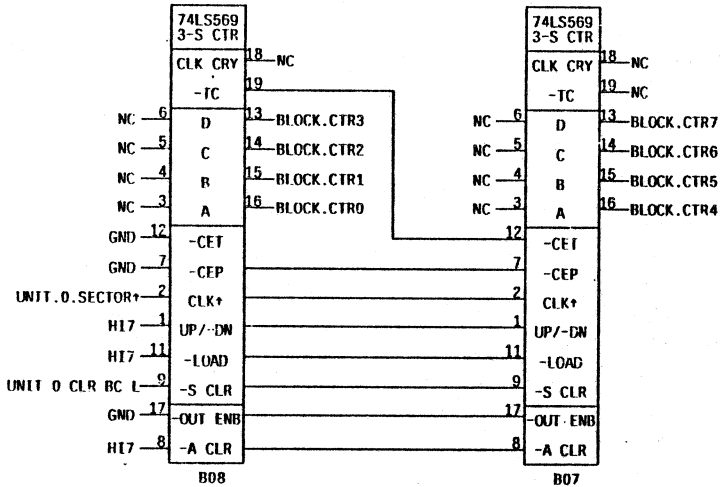

- J01-20 TRIDENT\_SECTOR/
  - J01-45 TRIDENT\_END\_OF\_CYL/
  - J01-19 TRIDENT\_ADDR\_MK\_DET/
  - J01-44 TRIDENT\_OFFSET/
  - J01-18 VCC
  - J01-43 TRIDENT\_INDEX/
  - J01-17 VCC
  - J01-42 TRIDENT\_READY/
  - J01-16 GND
  - J01-41 TRIDENT\_READ\_ONLY/
  - J01-15 GND
  - J01-40 TRIDENT\_DEVICE\_CHECK/
  - J01-14 GND
  - J01-39 TRIDENT\_ON\_LINE/
  - J01-13 GND
  - J01-38 TRIDENT\_SEEK\_INC/
  - J01-12 GND
  - J01-37 TRIDENT\_SPARE/
  - J01-11 GND
  - J01-36 TRIDENT\_BUS9/
  - J01-10 GND
  - J01-35 TRIDENT\_BUS8/
  - J01-9 GND
  - J01-34 TRIDENT\_BUS7/
  - J01-8 GND
  - J01-33 TRIDENT\_BUS6/
  - J01-7 GND
  - J01-32 TRIDENT\_BUS5/
  - J01-6 GND
  - J01-31 TRIDENT\_BUS4/
  - J01-5 GND
  - J01-30 TRIDENT\_BUS3/
  - J01-4 GND
  - J01-29 TRIDENT\_BUS2/
  - J01-3 TRIDENT\_TER\_IN/
  - J01-28 TRIDENT\_BUS1/
  - J01-2 TRIDENT\_CTRL\_TAG/
  - J01-27 TRIDENT\_BUS0/
  - J01-1 TRIDENT\_CYL\_TAG/
  - J01-26 TRIDENT\_HEAD\_TAG/
- :J1: remove dedicated gnds 26-45  
:Delete pins 21 and 46

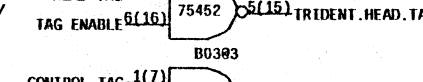
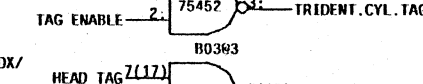
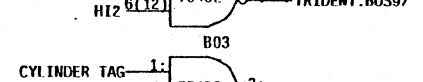
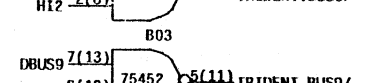
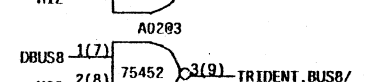
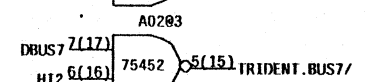
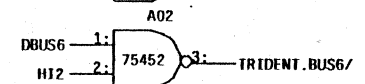
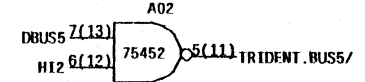
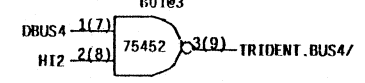
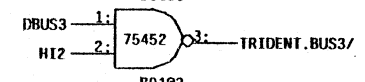
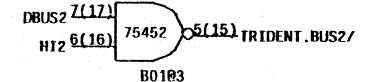
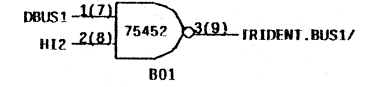
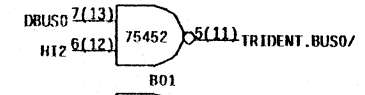
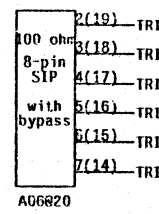
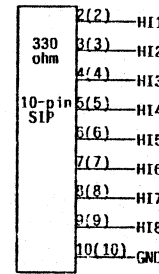
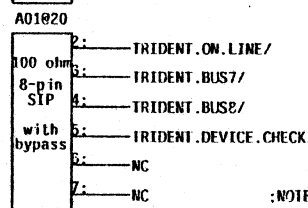
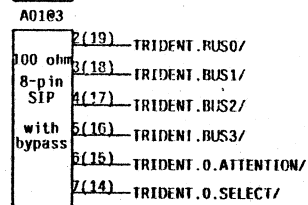
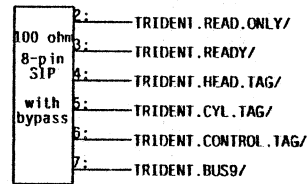
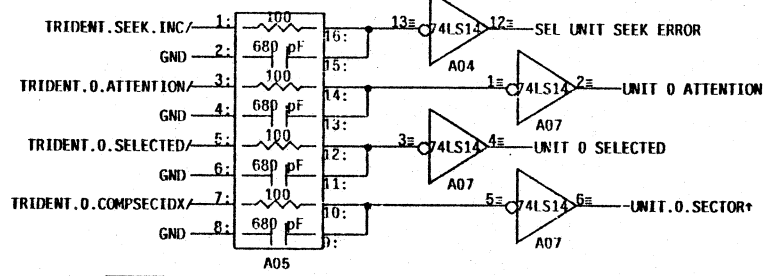
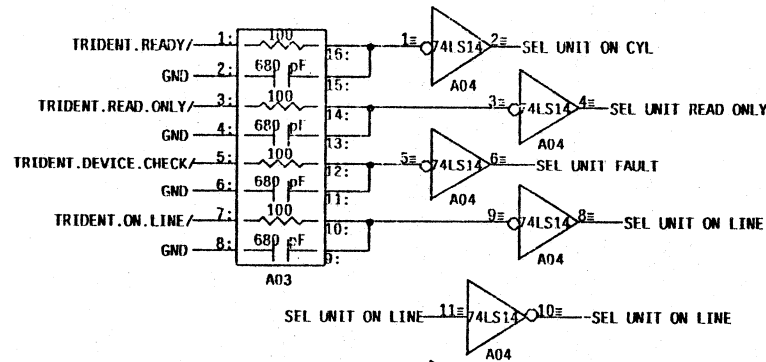

:NOTE- pinout differs on ser#1

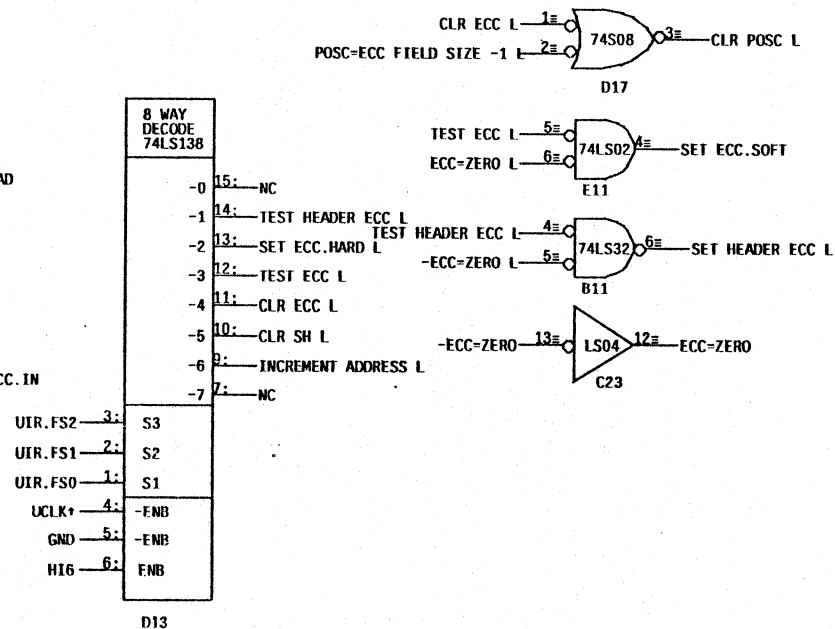
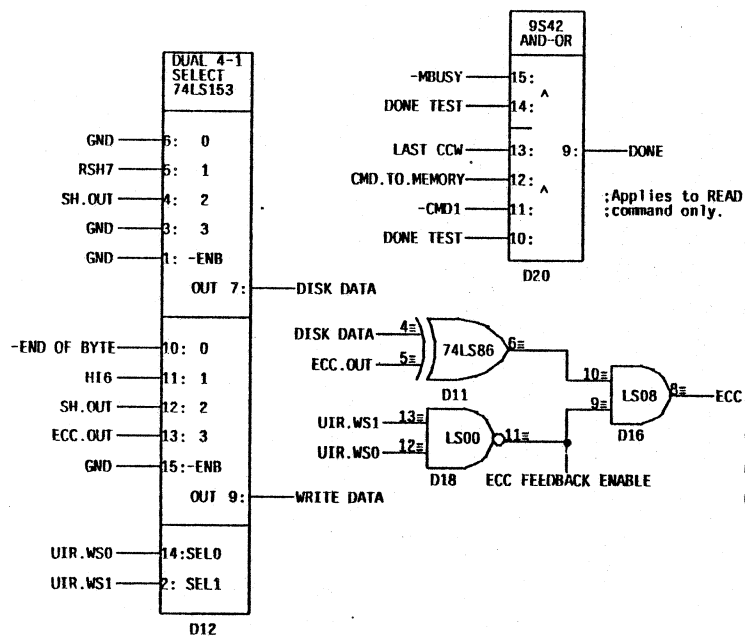
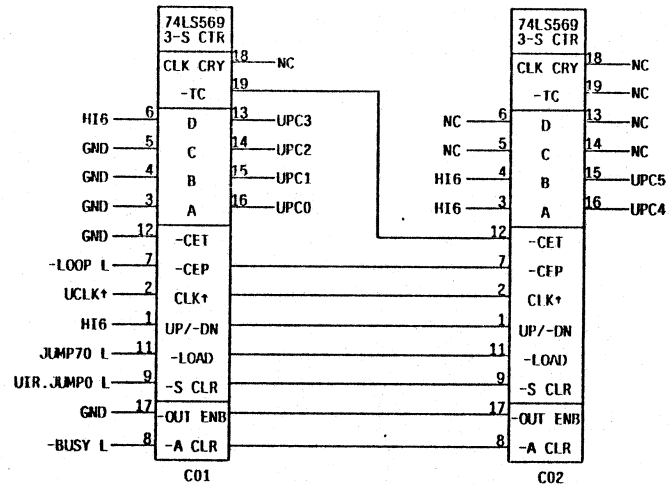
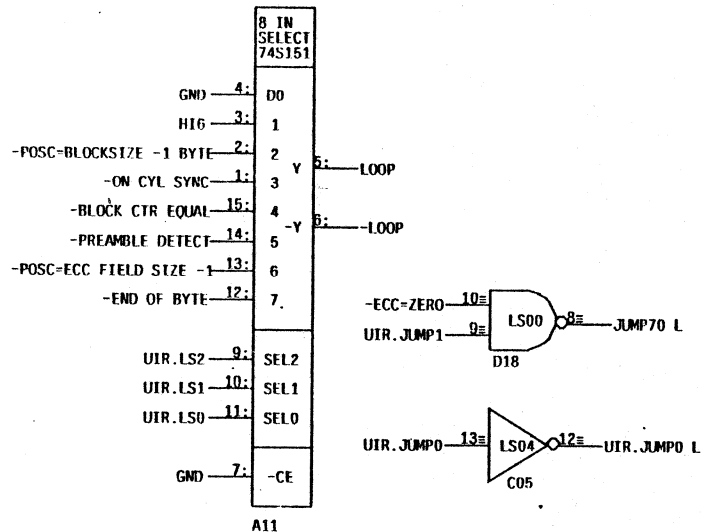

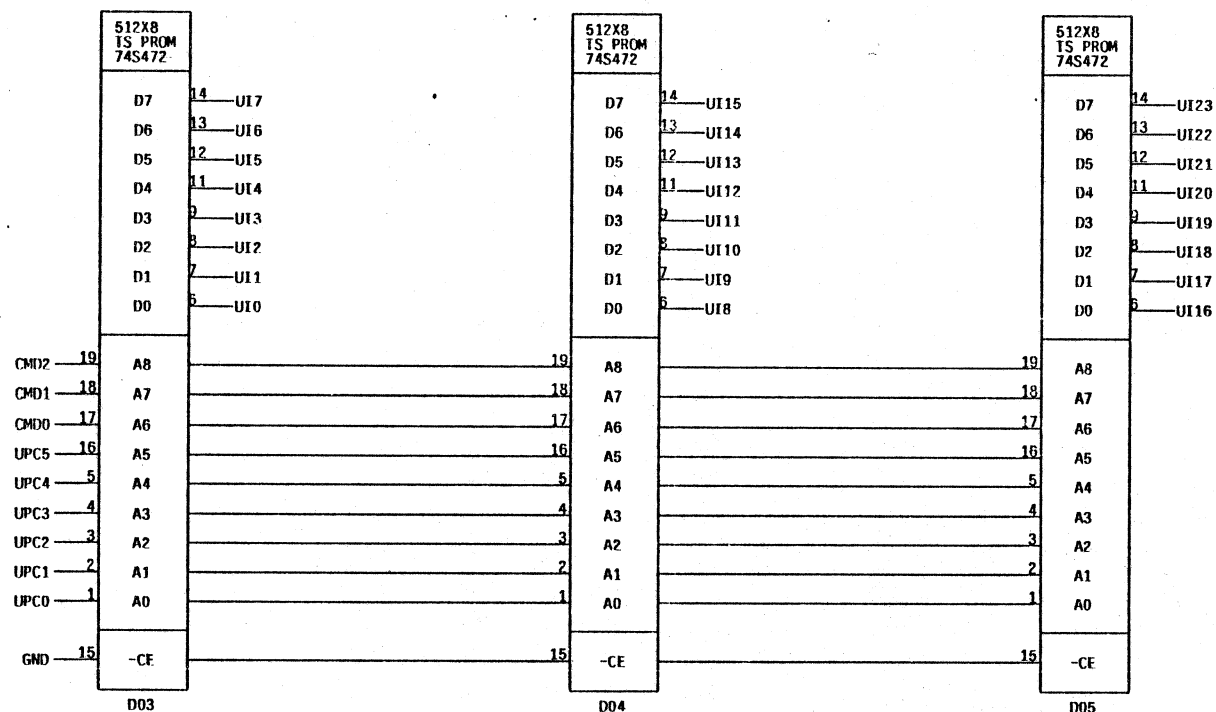
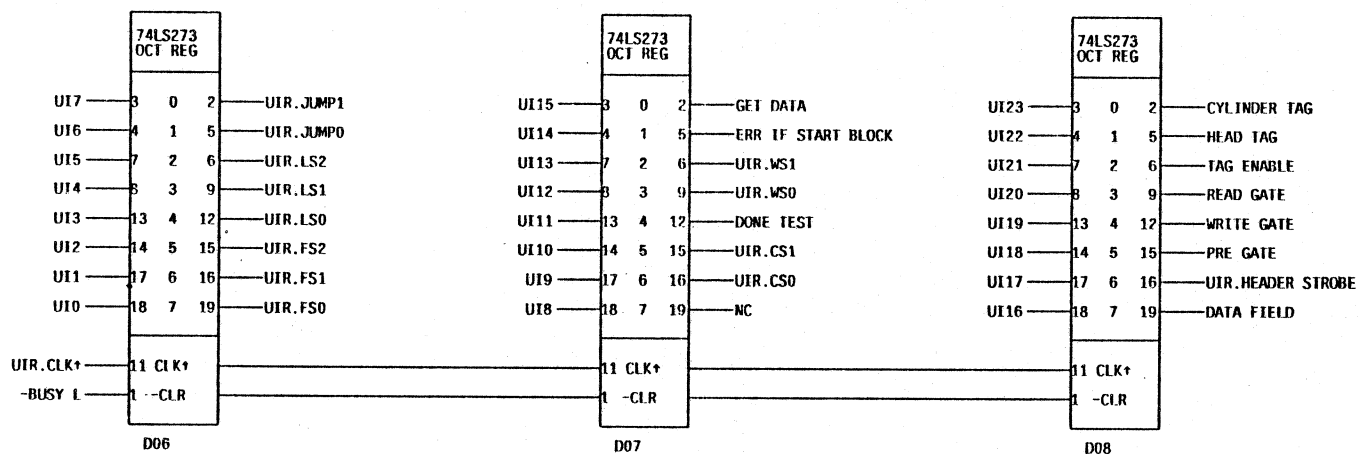

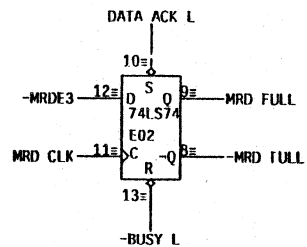
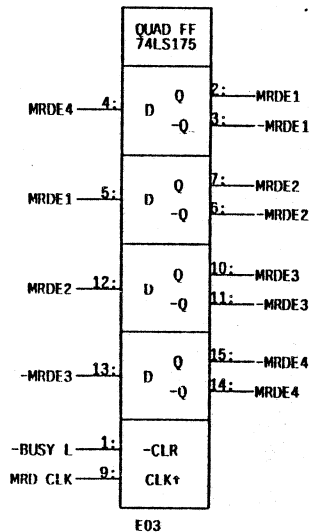
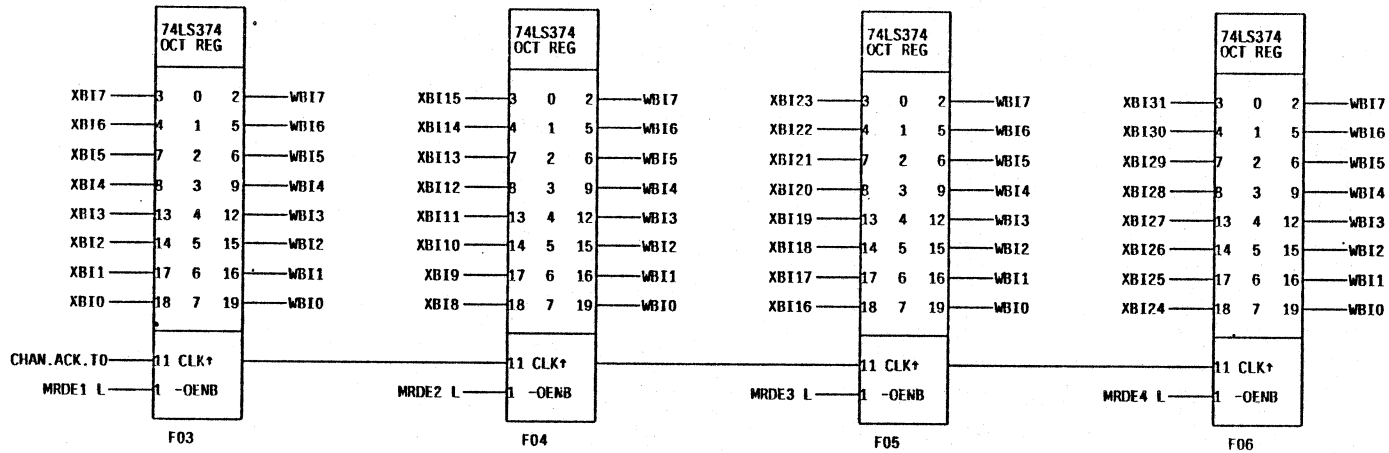
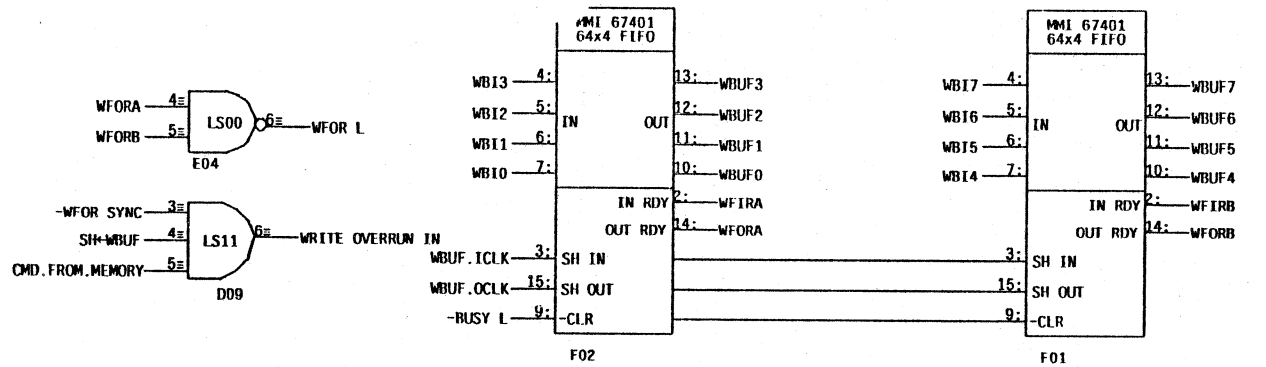

:Idle state has MRDE4 asserted.  
 :MRD FULL clears on same clock  
 :that sets MRDE4. Fifo will  
 :always gobble byte within 105 ns  
 :before channel can clobber it.

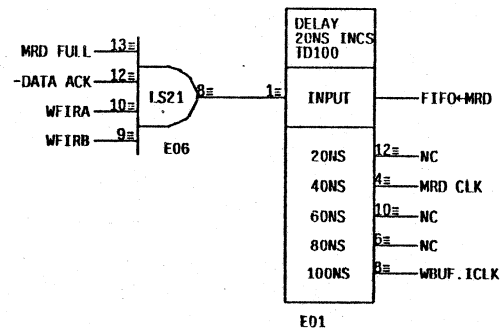

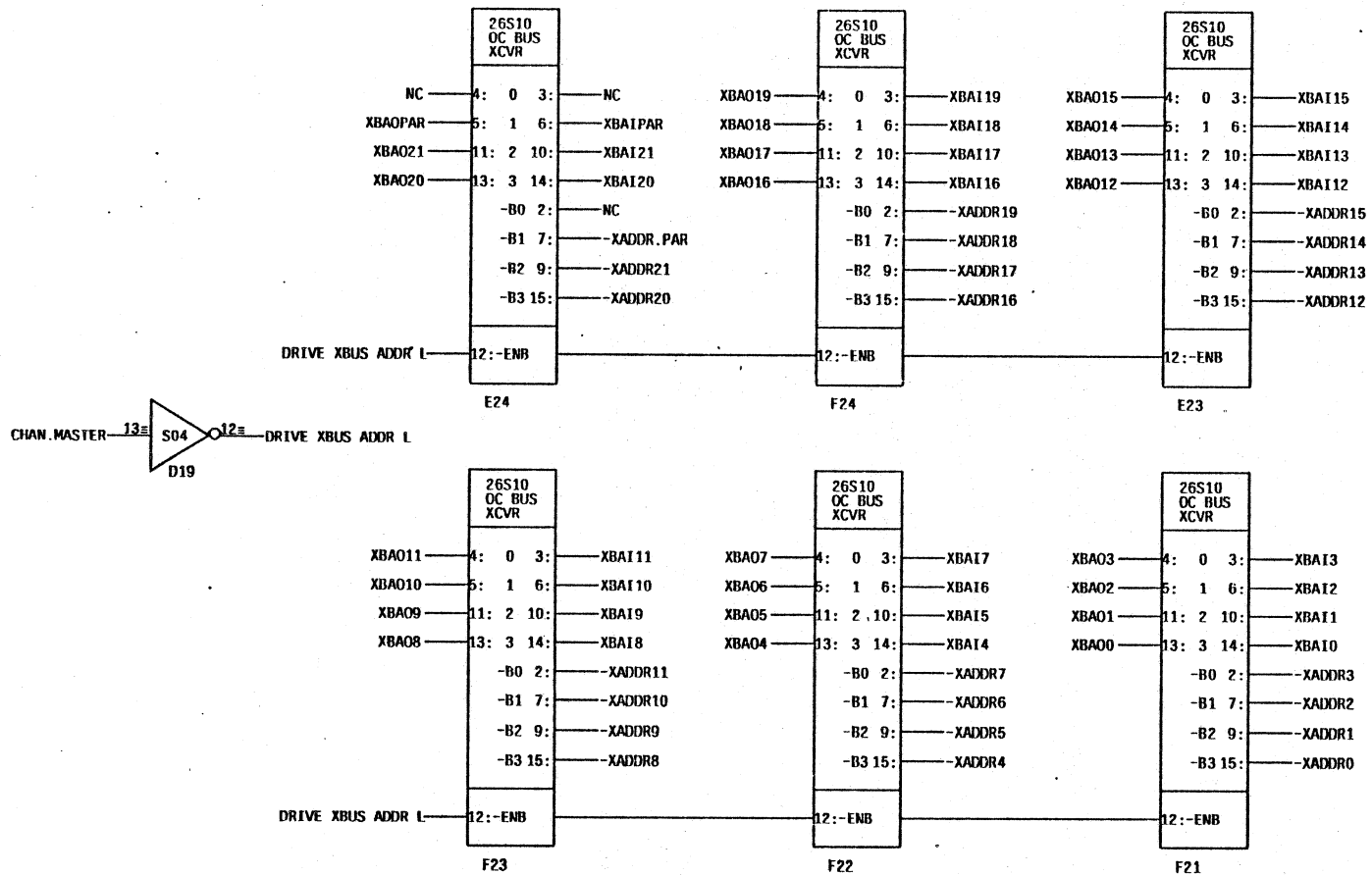



PDP-11 Unibus Chaosnet Interface CHAOS:UBCHNI UML 17-DEC-80 1800  
 \*\*\*\*\* DIP MAP \*\*\*\*\*

DM8838 QUBXCVC x	74LS74 QADTIM xx	74LS193 QADTIM x	74LS193 QADTIM x	74LS174 LMUCON x	74LS193 QADTIM x
F20	E20	D20	C20	B20	A20
DM8838 QUBXCVC x	74LS193 QADTIM x	74LS244 LMDATP x	74LS133 LMUCON x	74LS164 LMTURN x	74LS193 LMTURN x
F19	E19	D19	C19	B19	A19
DM8838 QUBXCVC x	74LS244 LMDATP x	74LS244 LMDATP x	74LS138 LMUCON x	74LS164 LMTURN x	74LS193 LMTURN x
F18	E18	D18	C18	B18	A18
DM8838 QUBXCVC x	74LS244 LMDATP x	74LS244 LMDATP x	74LS244 LMDATP x	74S04 QUBINT x000xx	74LS193 LMTURN x
F17	E17	D17	C17	B17	A17
74S38 QUBINT xxxx	25LS2521 QADADR x	74LS244 LMDATP x	74LS244 LMDATP x	74LS02 QUBINT xxxx	74LS161 LMTURN x
F16	E16	D16	C16	B16	A16
74S38 QUBINT xxxx	25LS2521 QADADR x	74S32 LMRCTL xxxx	74S00 LMTBFC xxxx	74S74 LMMODU xx	1D100 QUBINT x
F15	E15	D15	C15	B15	A15
74S175 QUBINT x	DUMMY QUBINT x	74S112 LMTURN xx	74S00 LMTBFC xxxx	74S04 LMTBFC xxxxxx	74LS163 QADTIM x
F14	E14	D14	C14	B14	A14
DUMMY QUBINT x	74S04 QADADR xxxxxx	74S112 LMTBFC xx	25LS193 LMTBFC x	74 165 LMTBFC x	74S37 QADADR xxox
F13	E13	D13	C13	B13	A13
74S00 QUBINT xxxx	74LS163 QADTIM x	DUMMY LMMYNM x	25LS193 LMTBFC x	74 165 LMTBFC x	1D250 QADADR x
F12	E12	D12	C12	B12	A12
74LS10 QUBINT xxx	74LS02 QADADR xxox	P SIP100 LMMYNM x	25LS193 LMTBFC x	1D100 LMDETC x	1D25 LMDETC x
F11	E11	D11	C11	B11	A11
DM8838 QUBINT x	74S08 LMRCTL xxxx	DUMMY LMMYNM x	2147 LMTBFC x	74S08 LMTBFC xxxx	74S288 LMMODU x
F10	E10	D10	C10	B10	A10

PDP-11 Unibus Chaosnet Interface CHAOS:UBCHNI UML 17-DEC-80 1801  
 \*\*\*\*\* DIP MAP \*\*\*\*\*

DM8837A QUBXCV x	DUMMY QADADR x	74 279 LMRCTL OXOX	9401 LMTBUF x	74S04 LMDETC XXXXXX	74S112 LMMODU xx
F09	E09	D09	C09	B09	A09
DM8837A QUBXCV x	74S74 QADADR xx	74S74 LMRCTL xx	74S51 LMTBUF xx	74S02 LMTBFC XXXX	74S374 LMMODU x
F08	E08	D08	C08	B08	A08
DM8837A QUBXCV x	PULLUP-D QADADR x	74S00 LMRBUF XXXX	9401 LMRBUF x	74LS164 LMRBUF x	74LS164 LMRBUF x
F07	E07	D07	C07	B07	A07
DM8837A QUBXCV x	74S251 LMMYNM x	25LS193 LMRBUF x	74S74 LMRCLK xx	74LS161 LMRCLK x	74S112 LMTCLK xx
F06	E06	D06	C06	B06	A06
74S251 LMMYNM x	74S51 LMRBUF xx	25LS193 LMRBUF x	74S37 LMRBUF XXXX	74LS161 LMRCLK x	EXAR-CL LMTCLK x
F05	E05	D05	C05	B05	A05
74LS161 LMMYNM x	74S00 LMUCON XXXX	25LS193 LMRBUF x	2147 LMRBUF x	TD100 LMDETC x	26S02 LMRCTL xx
F04	E04	D04	C04	B04	A04
74LS161 LMMYNM x	74S00 LMRCTL XXXX	74S04 LMTCLK XXXXXX	TD250 LMRCLK x	74S163 LMTCLK x	DUMMY LMLNDR x
F03	E03	D03	C03	B03	A03
74LS161 LMMYNM x	74S158 LMLNDR x	74S10 LMMODU xxx	74S08 LMRBUF xxxx	74S74 LMDETC xx	26LS31 LMLNDR xxxx
F02	E02	D02	C02	B02	A02
74S11 LMMODU xxx	74S174 LMMYNM x	74S287 LMMYNM x	74S74 LMDETC xx	74S04 LMRCLK XXXXXX	26LS33 LMLNDR xxxx
F01	E01	D01	C01	B01	A01



PDP-11 Unibus Chaosnet Interface CHAOS;UBCHNI UML 17-DEC-80 1803  
\*\*\*\*\* EDGE CONNECTIONS Flags: (# Output, @ Terminator, ---- Dedicated ground, ++++ Dedicated power) \*\*\*\*\*

-J01-

-J02-

-J03-

-J04-

01	01 GND	# 01	01
02	02 INTERFERE+	02	02
03	03 INTERFERE-	# 03	03
04	04 GND	# 04	04
05	05 RCVR.DATA+	05	05
06	06 RCVR.DATA-	06	06
07	07 GND	# 07	07
08	08 TRANS.DATA+	# 08	08
09	09 TRANS.DATA-	# 09	09
10	10 GND	# 10	10
11	11	11	11
12	12	12	12
13	13	13	13
14	14	14	14
15	15	15	15
16	16	16	16
17	17	17	17
18	18	18	18
19	19	19	19
20	20	20	20
21	21	21	21
22	22	22	22
23	23	23	23
24	24	24	24
25	25 GND	# 25	25
26	26	26	26
27	27 GND	# 27	27
28	28 GND	# 28	28
29	29 GND	# 29	29
30	30 GND	# 30	30
31	31 GND	# 31	31
32	32 GND	# 32	32
33	33 GND	# 33	33
34	34 GND	# 34	34
35	35 GND	# 35	35
36	36	36	36
37	37	37	37
38	38	38	38
39	39	39	39
40	40	40	40
41	41		
42	42		
43	43		
44	44		
45	45		
46	46		
47	47		
48	48		
49	49		
50	50		

PDP-11 Unibus Chaosnet Interface CHAOS:UBCHNI UML 17-DEC-80 1803  
\*\*\*\*\* EDGE CONNECTIONS Flags: (# Output, @ Terminator, ---- Dedicated ground, ++++ Dedicated power) \*\*\*\*\*

-J05-

-J06-

-J07-

-J08-

01	01	01	01
02	02	02	02
03	03	03	03
04	04	04	04
05	05	05	05
06	06	06	06
07	07	07	07
08	08	08	08
09	09	09	09
10	10	10	10
11	11	11	11
12	12	12	12
13	13	13	13
14	14	14	14
15	15	15	15
16	16	16	16
17	17	17	17
18	18	18	18
19	19	19	19
20	20	20	20
21	21	21	21
22	22	22	22
23	23	23	23
24	24	24	24
25	25	25	25
26	26	26	26
27	27	27	27
28	28	28	28
29	29	29	29
30	30	30	30
31	31	31	31
32	32	32	32
33	33	33	33
34	34	34	34
35	35	35	35
36	36	36	36
37	37	37	37
38	38	38	38
39	39	39	39
40	40	40	40
41	41		
42	42		
43	43		
44	44		
45	45		
46	46		
47	47		
48	48		
49	49		
50	50		

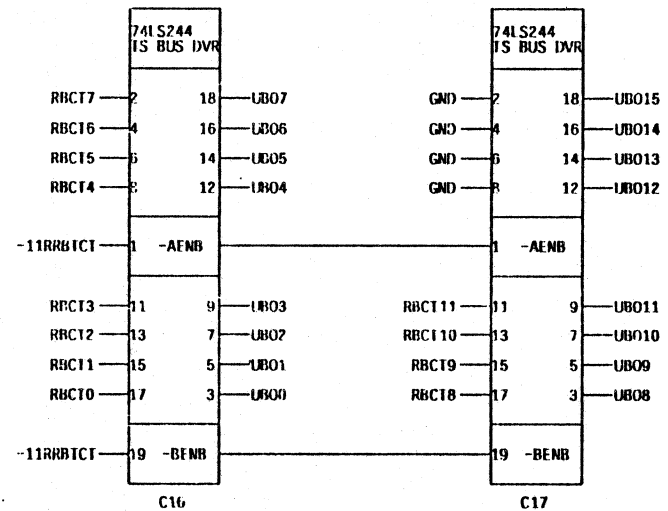
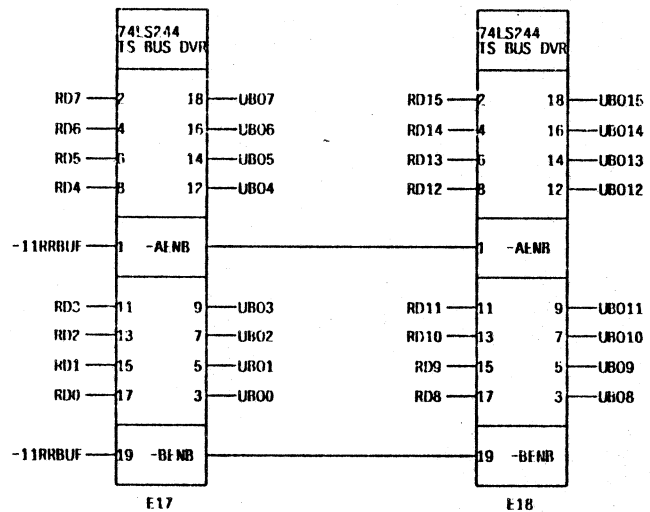
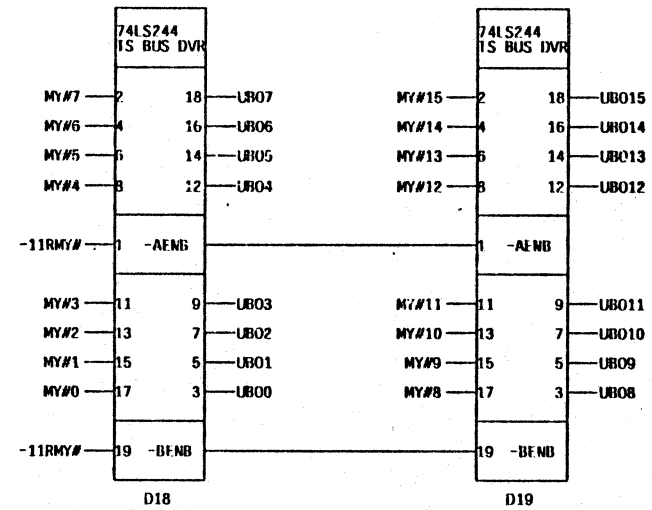
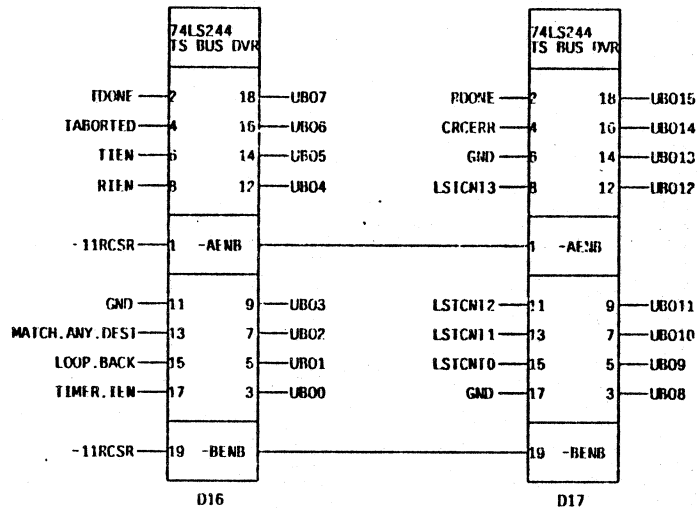

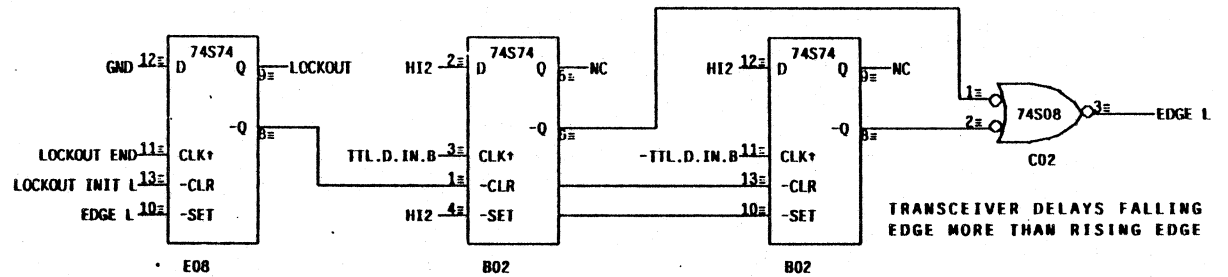
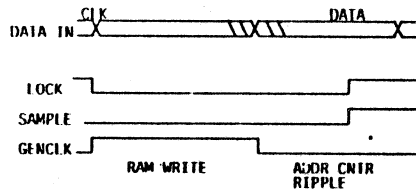

SAMPLE should be timed to occur in the middle of the data part of the cycle. Normally, this will be .75 of the cycle time less 15-25 ns. LOCKOUT END should be 5 ns earlier.

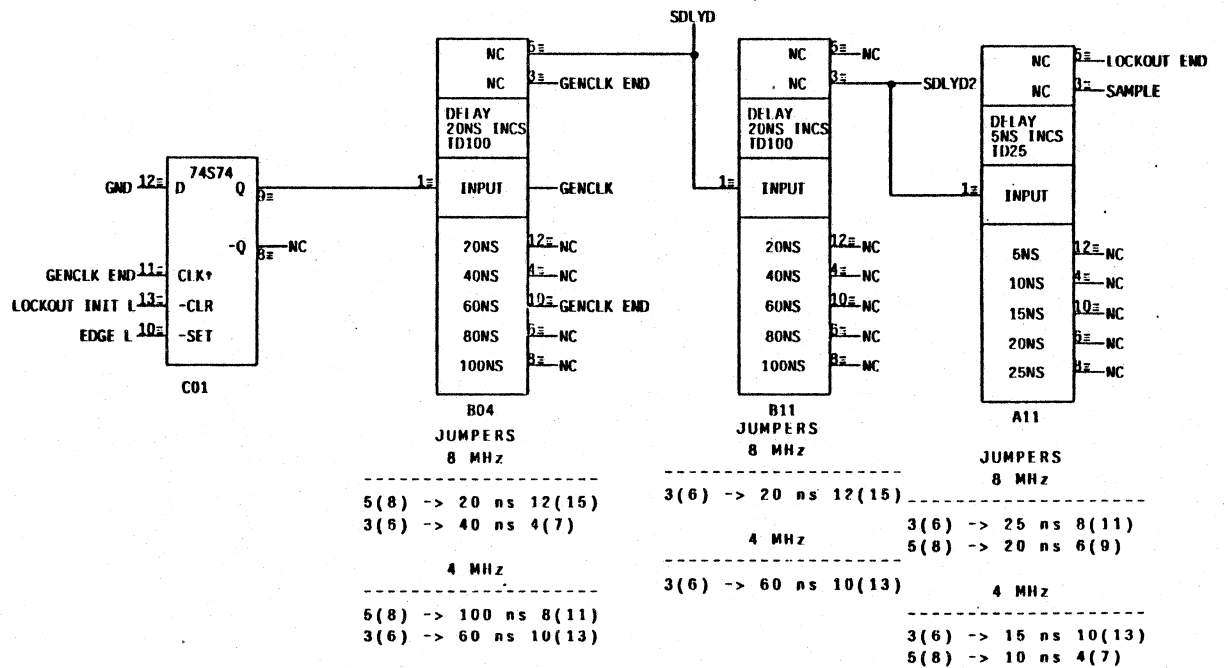
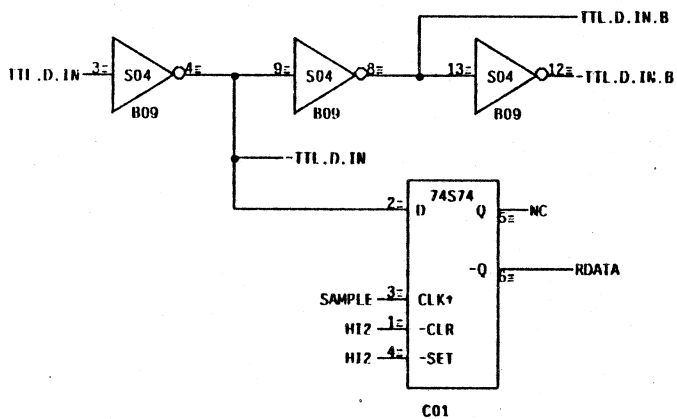
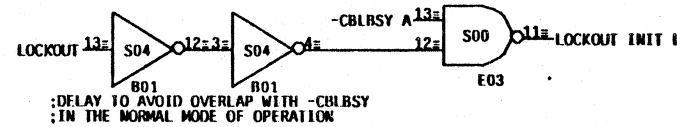

:=26LS32

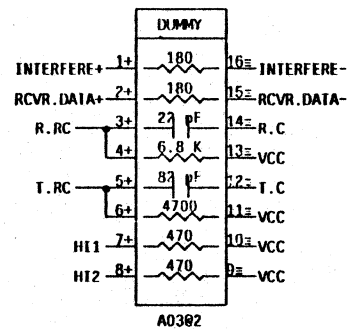
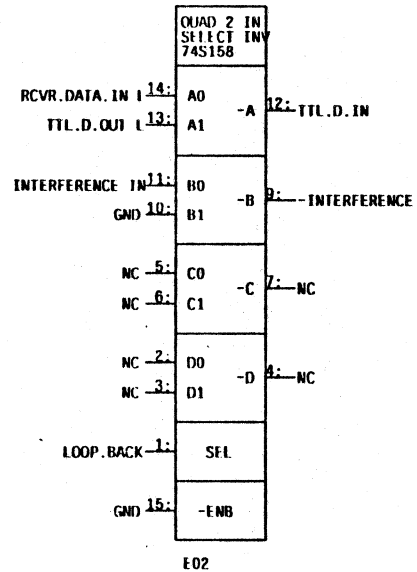
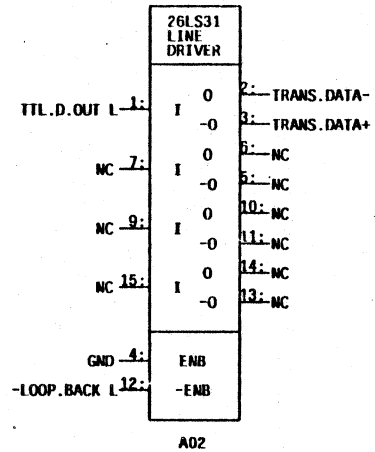
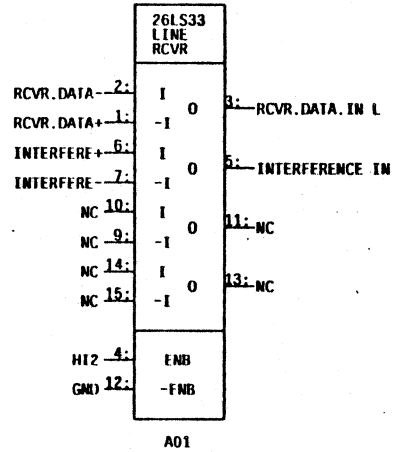



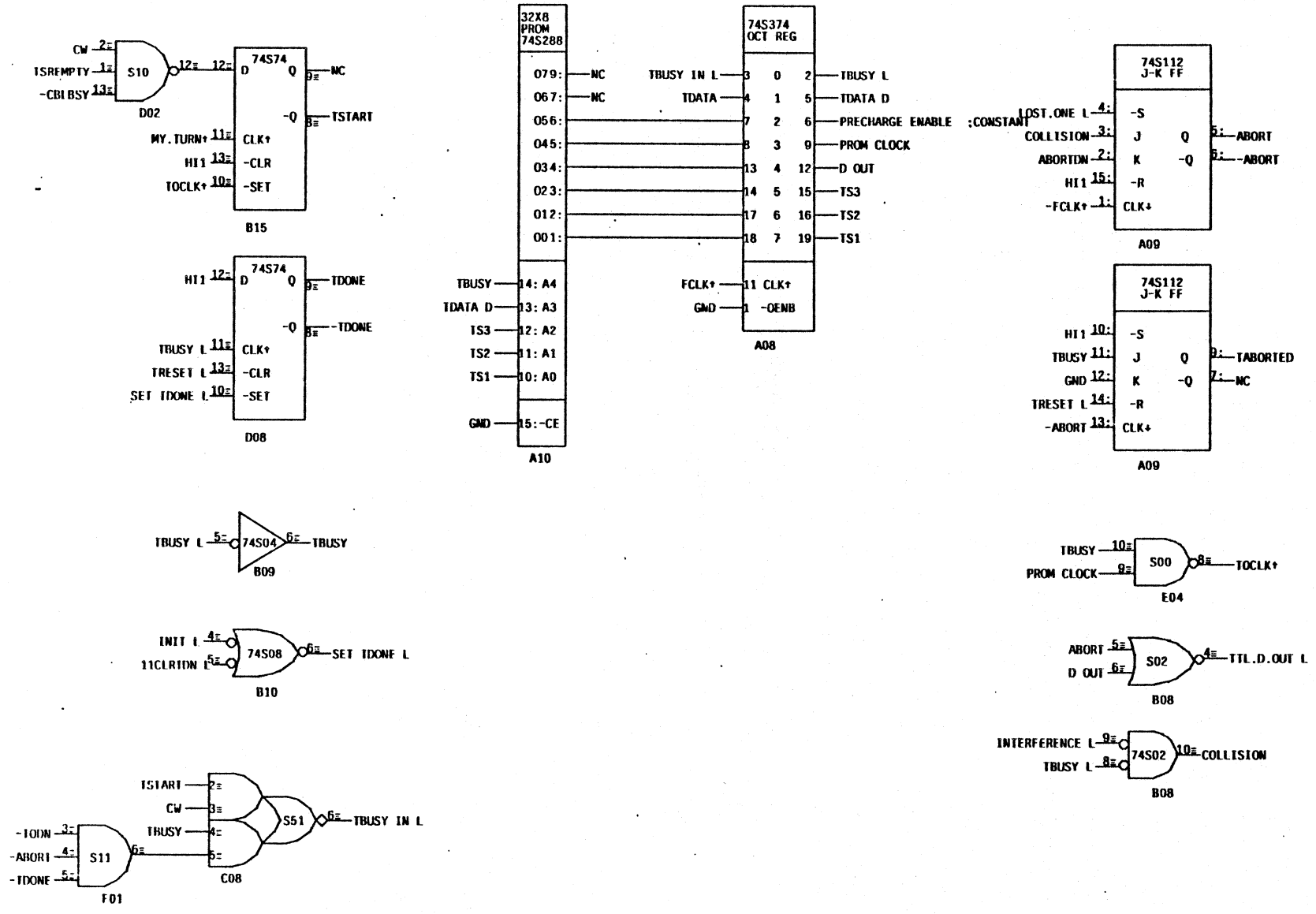

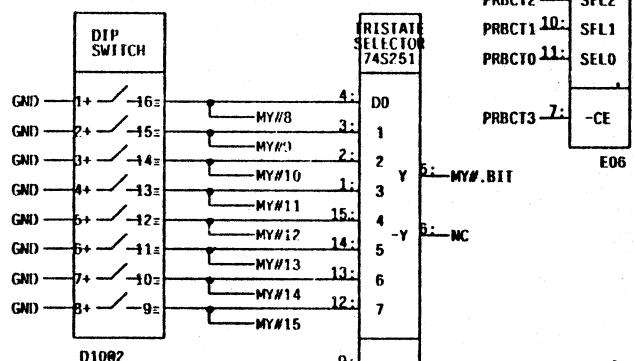
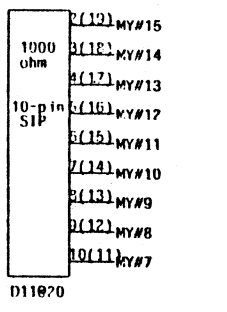
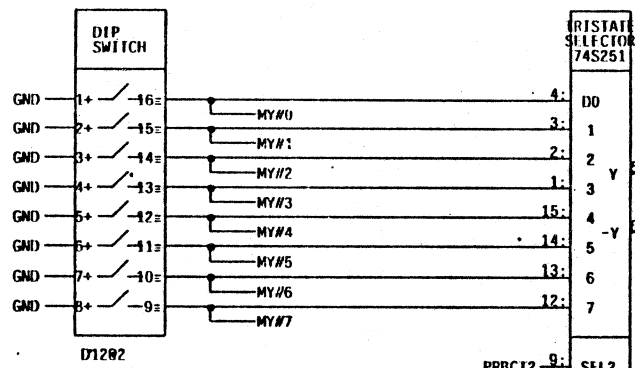
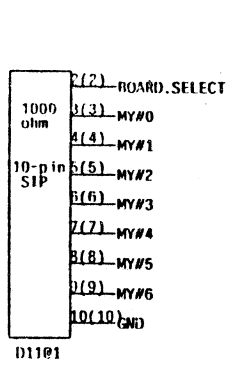

:SIPS are 750-101-RIK

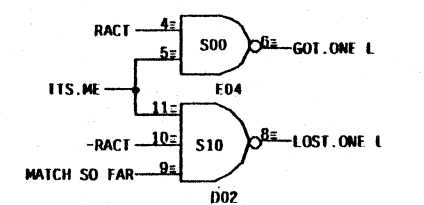
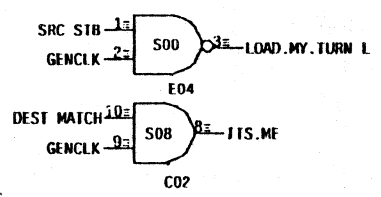
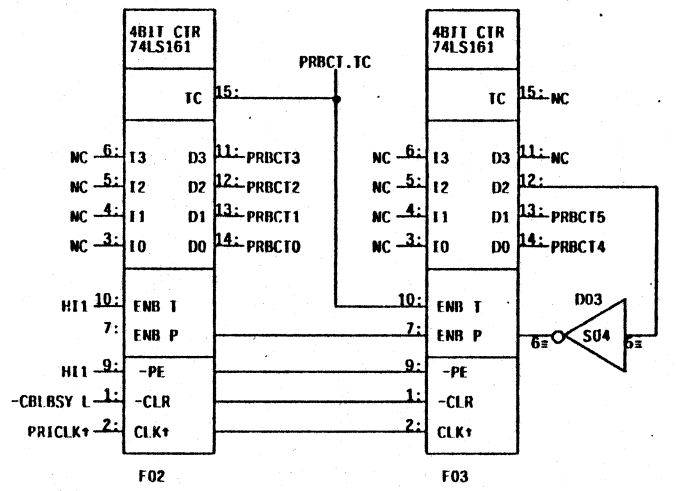
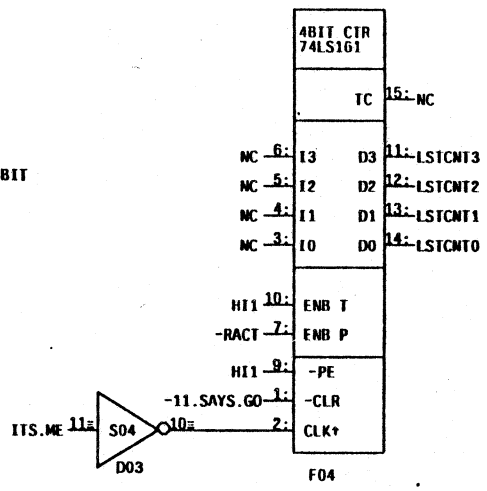
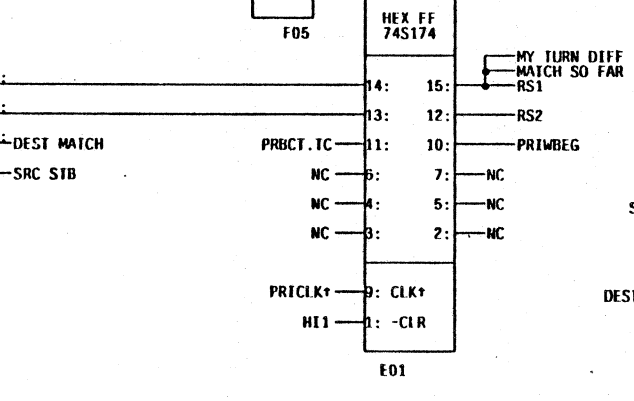
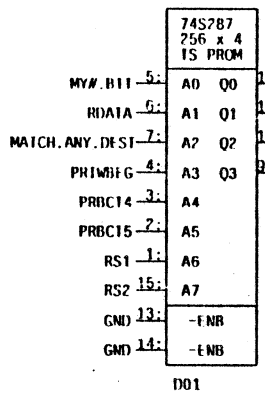

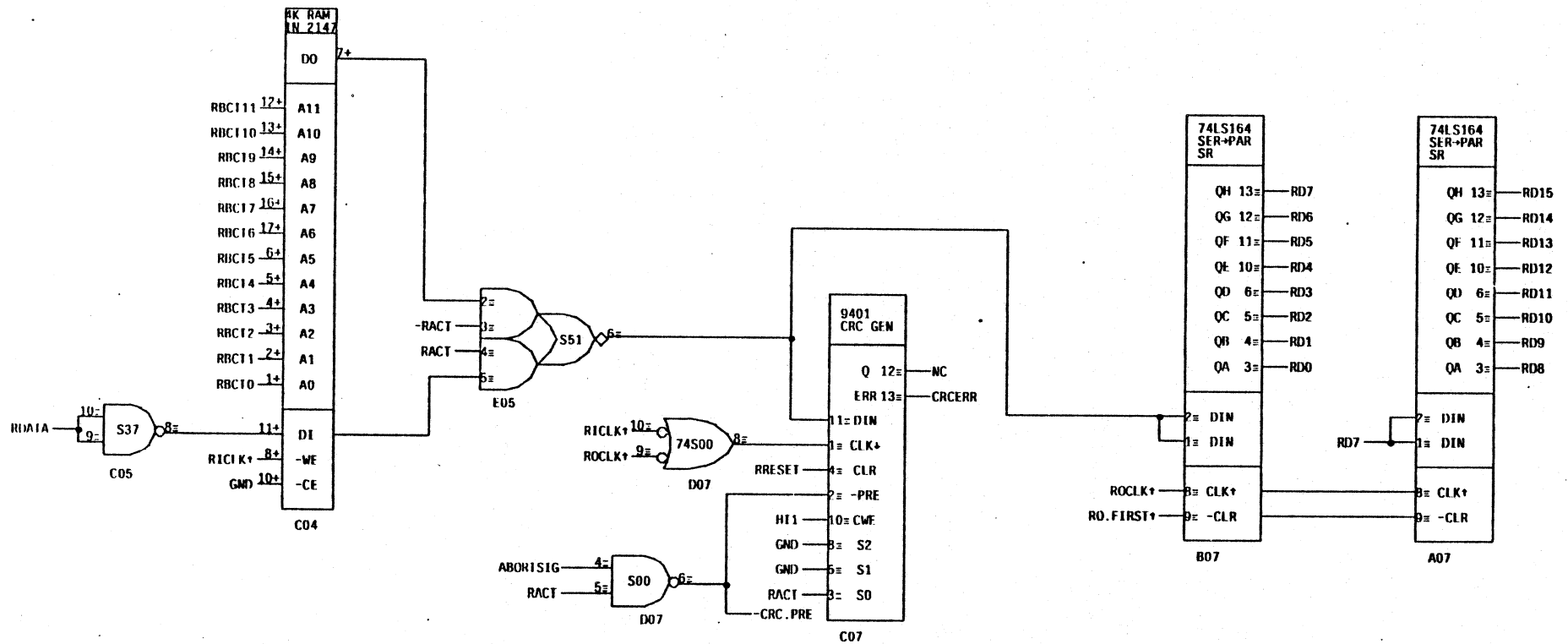
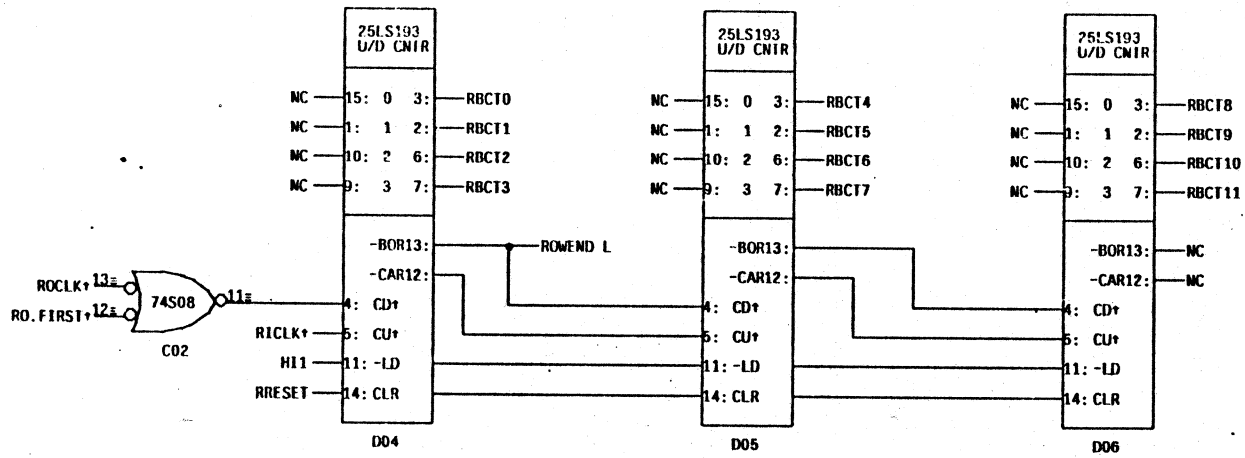

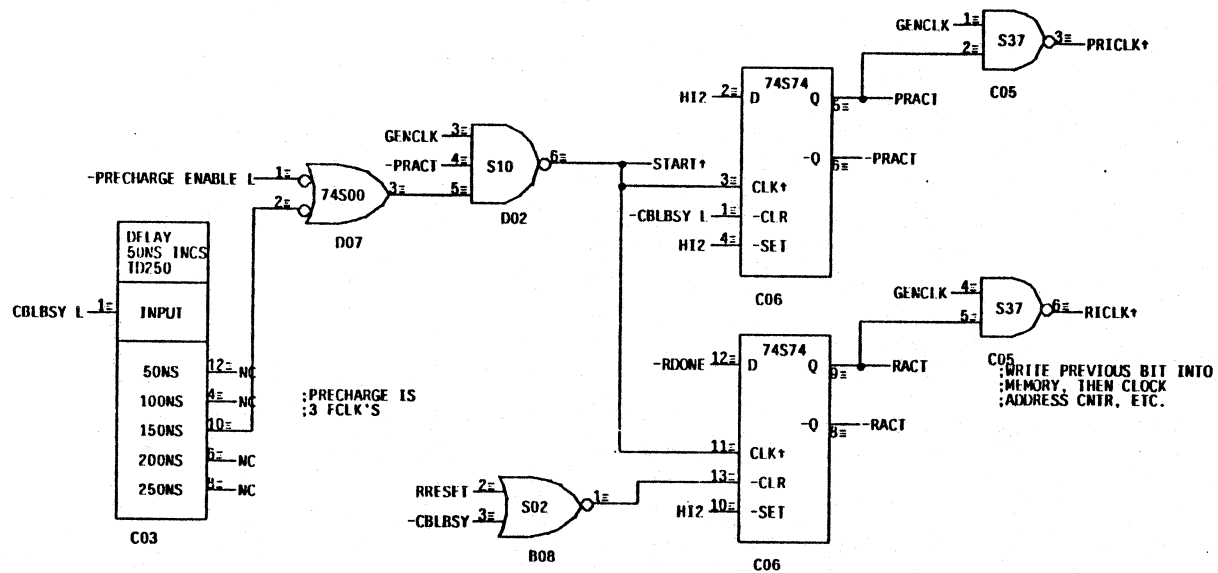
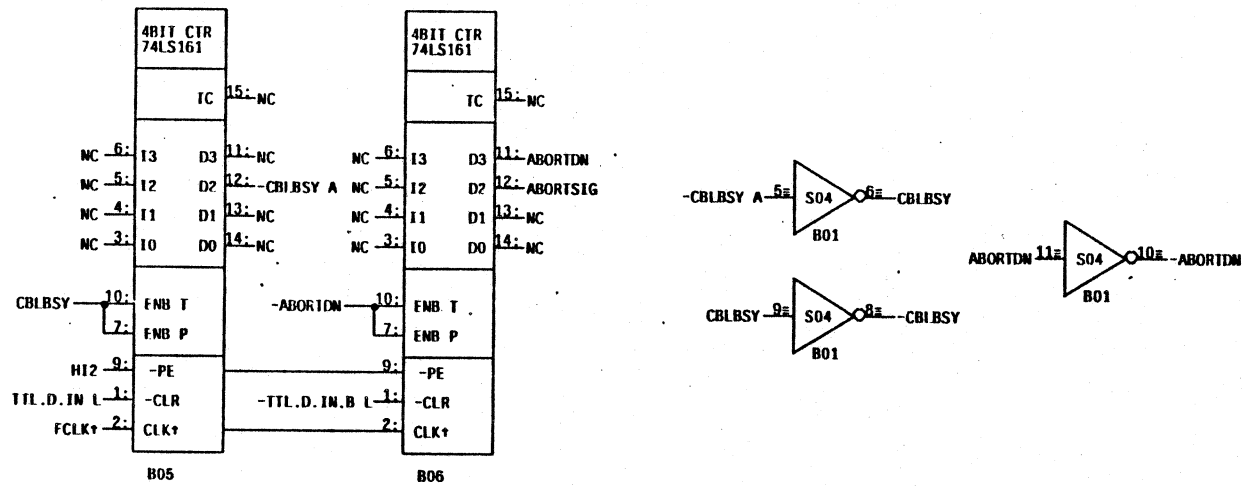

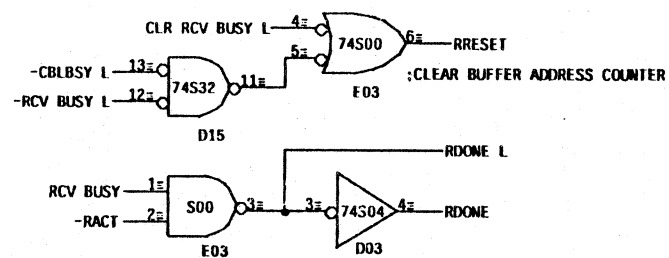
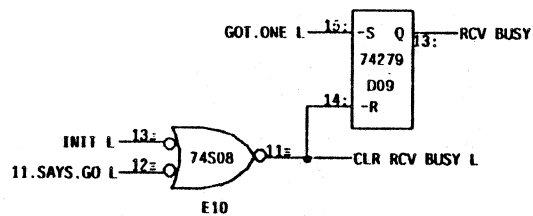
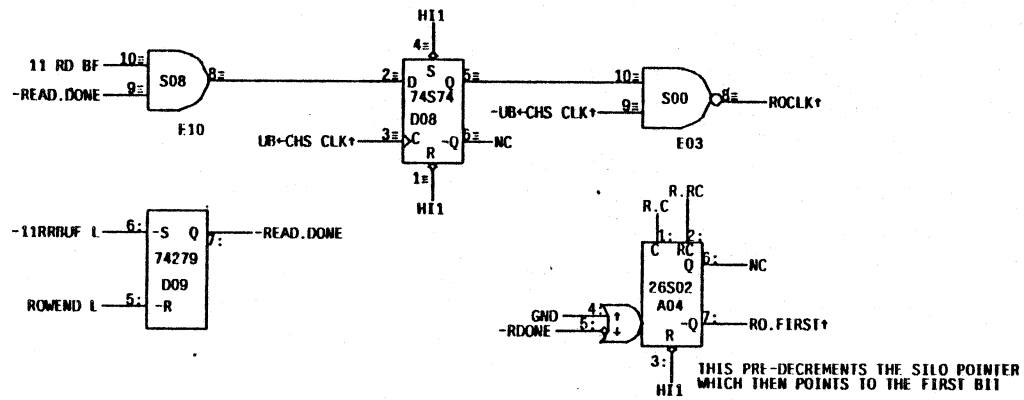

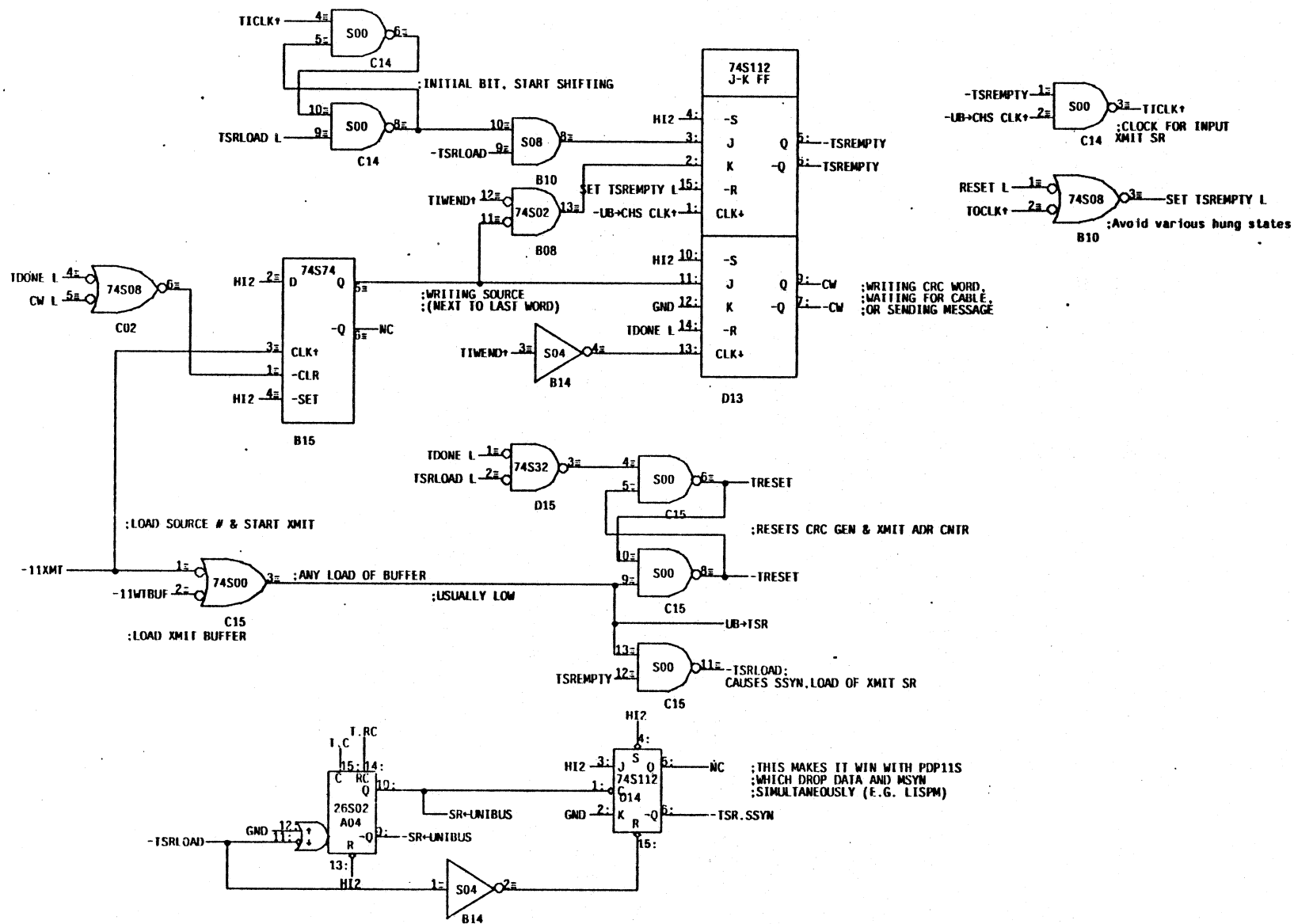

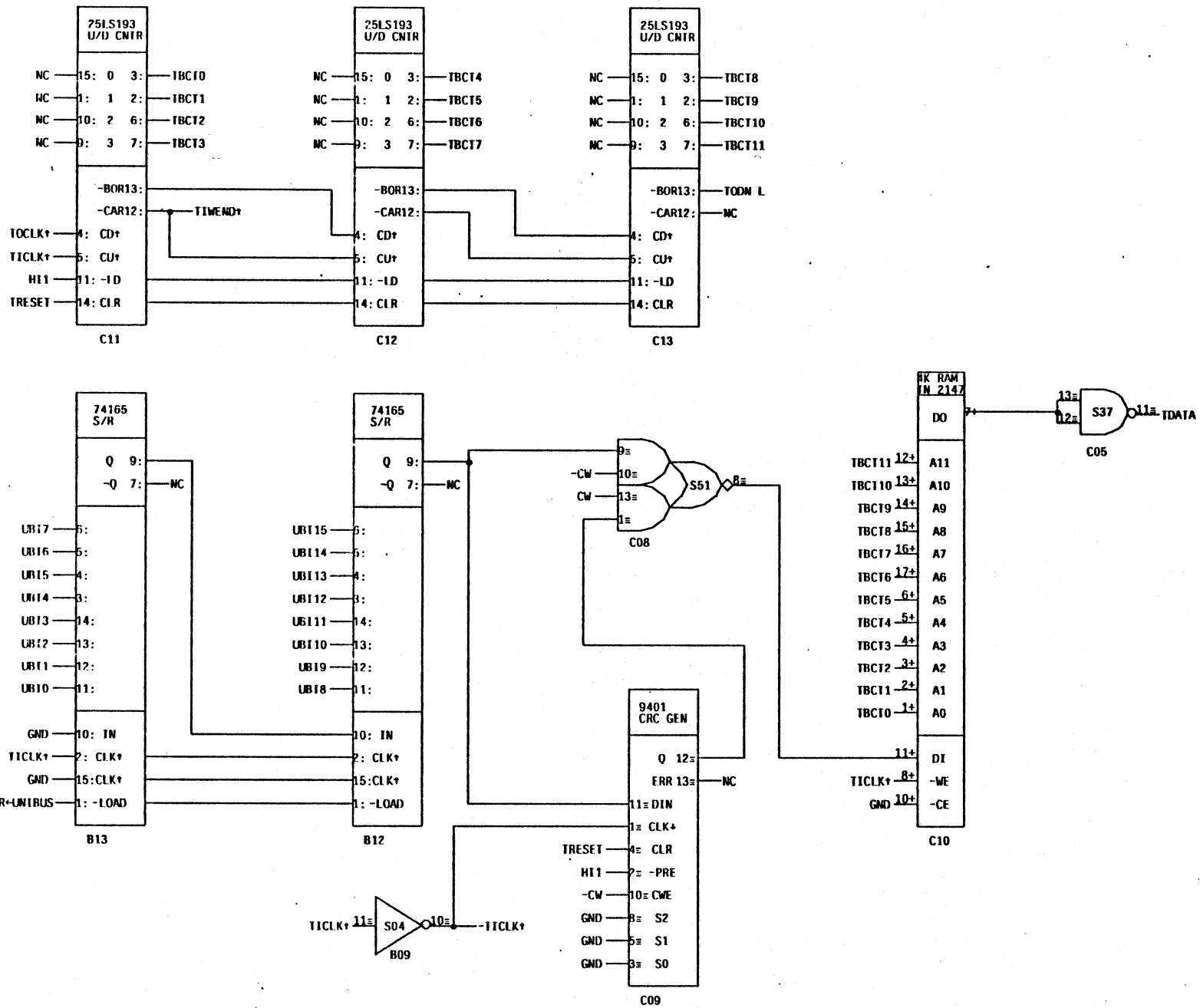

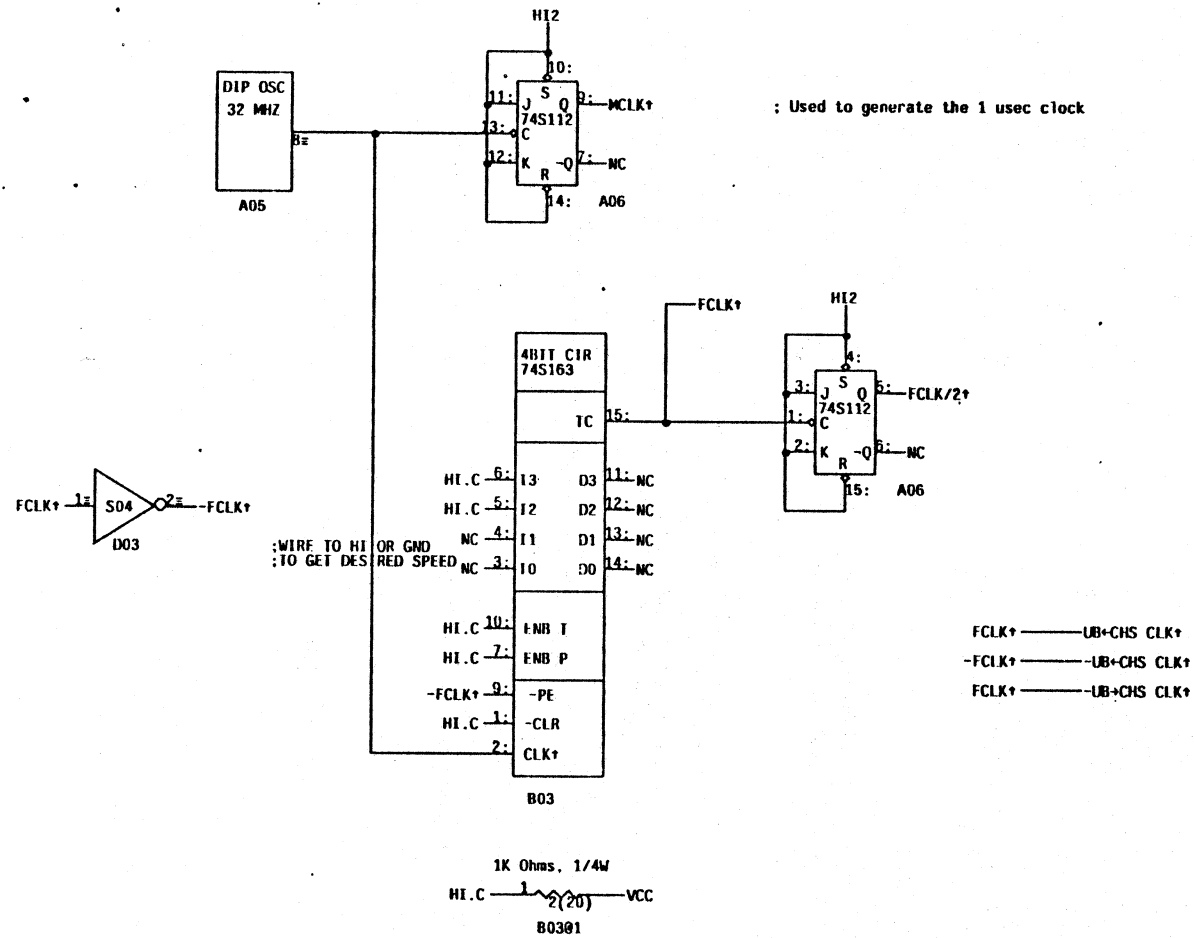



"My Turn" Counter

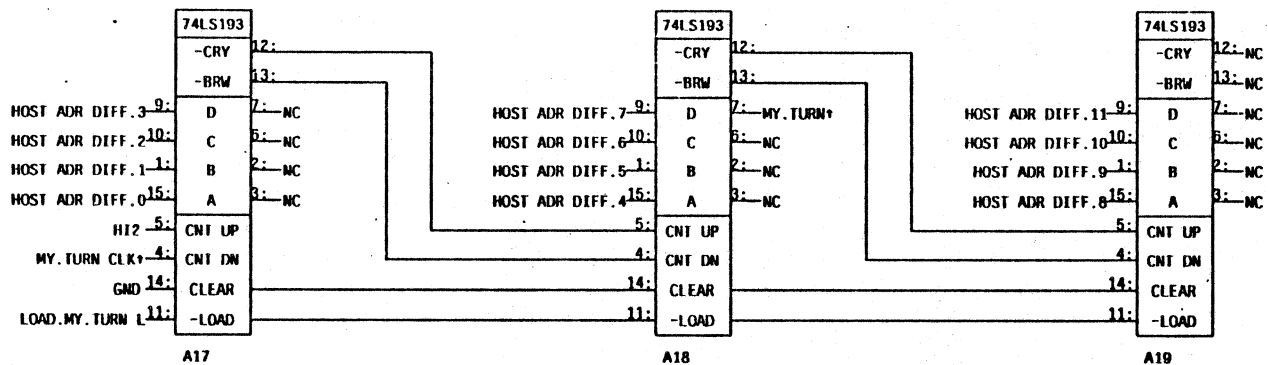

:DEFAULT IS MYTURN.MOD 2+7 OR 64 USECS

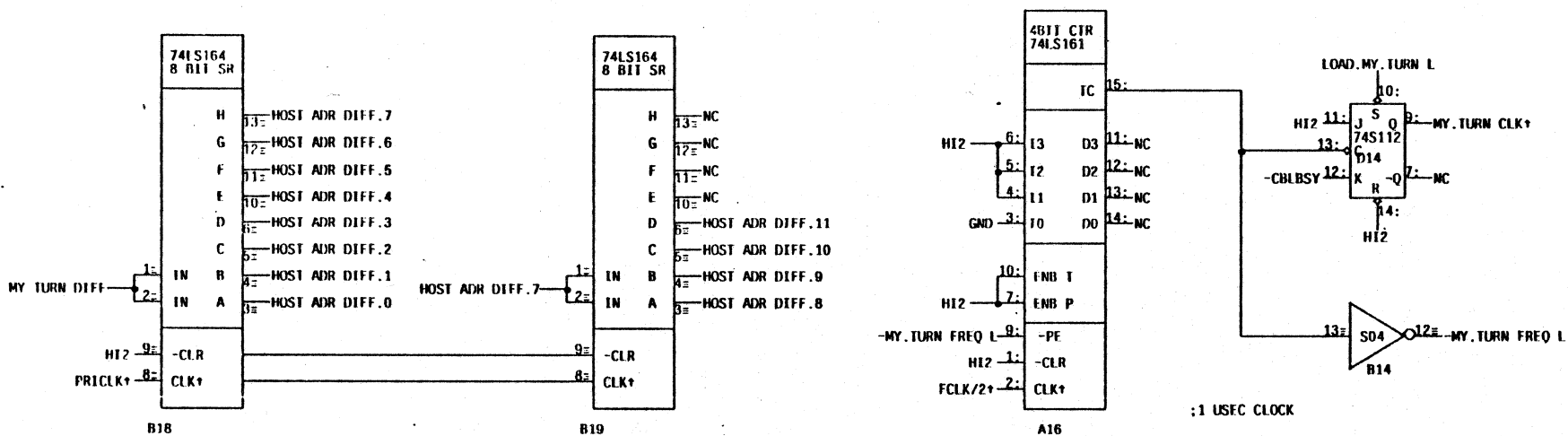

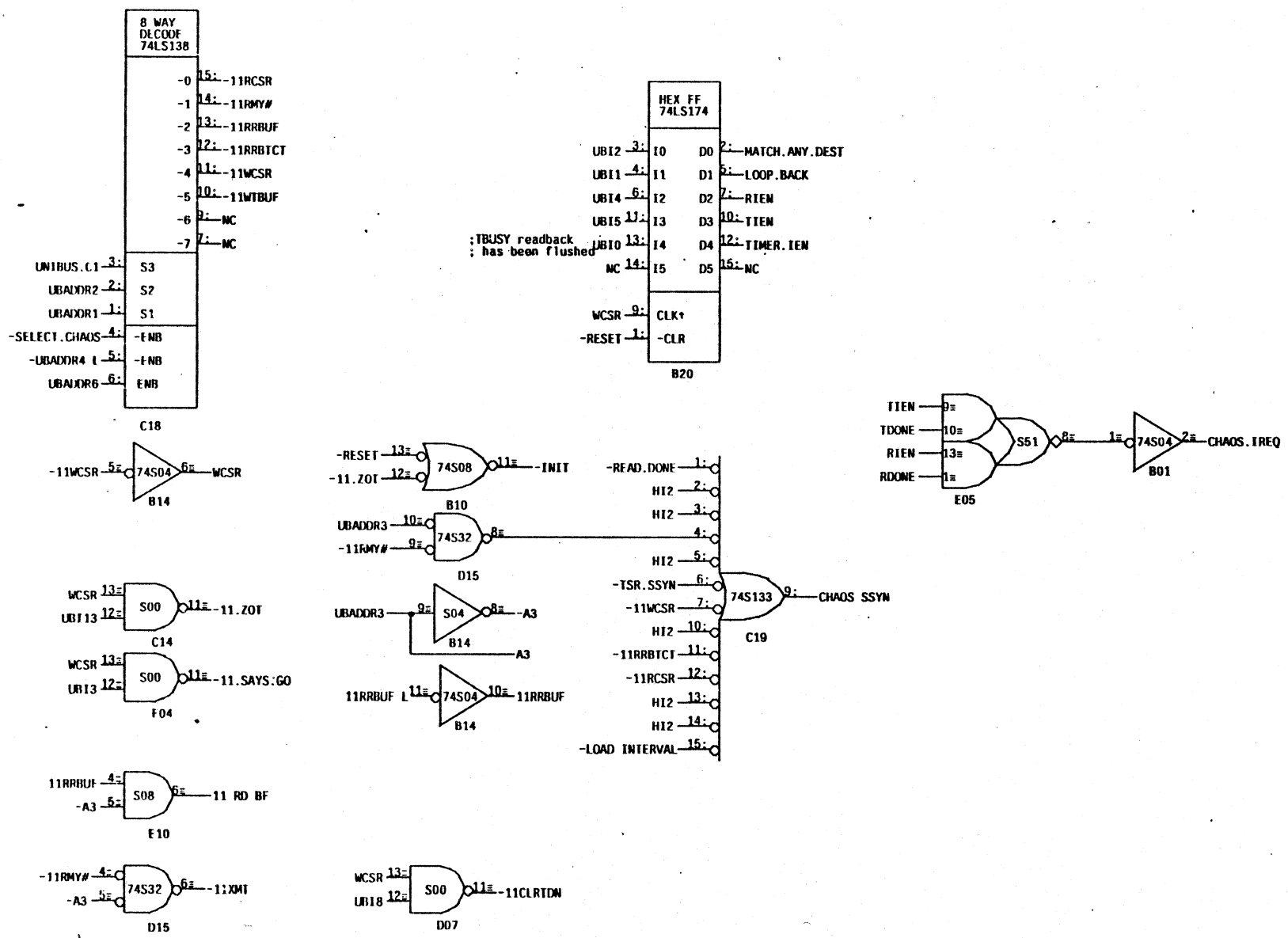

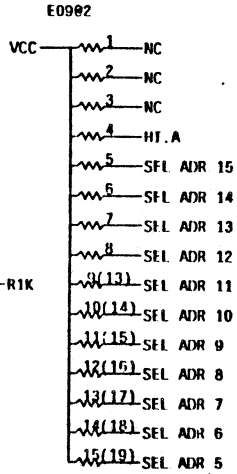
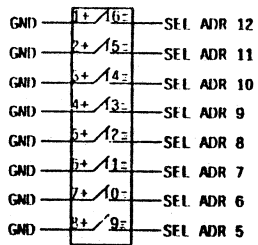

898-1-R1K

E0701

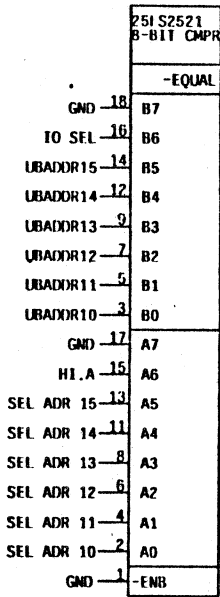

E16

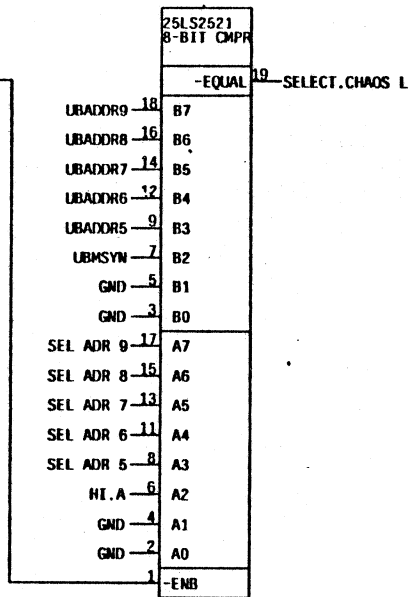

E15

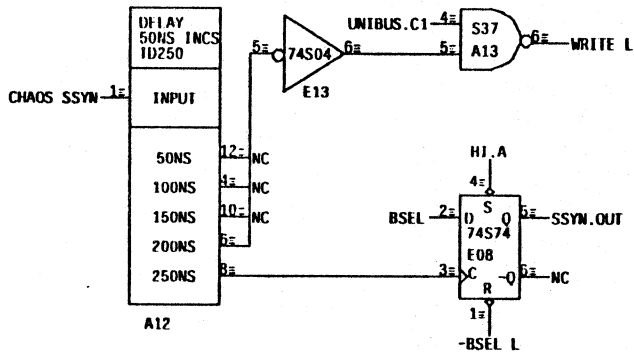
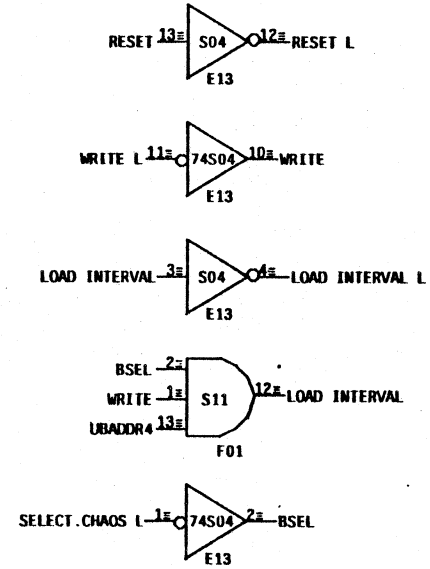

A12

UNIBUS.C1 READ

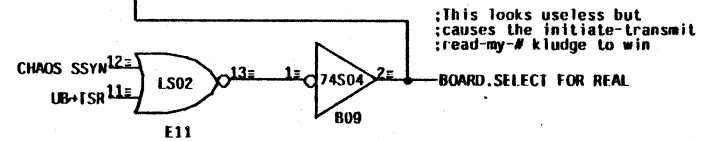
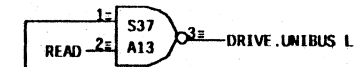
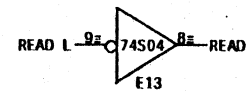

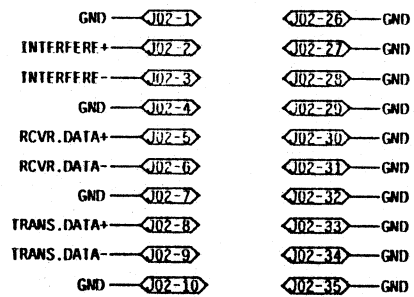



AC2 — GND  
 AF1 — NC  
 AN1 — NC  
 AI1 — GND  
 AC2 — GND  
 BF1 — NC  
 BN1 — NC  
 BT1 — GND  
 CA1 — GND  
 CC2 — GND  
 CM2 — GND  
 CN1 — GND  
 CS2 — GND  
 CT1 — GND  
 CC2 — GND  
 DF1 — NC  
 DH1 — NC  
 DI1 — GND

AB2 — -5V  
 BU2 — -5V  
 BD2 — -5V  
 BU2 — -5V

AA2 — +5V  
 BA2 — +5V  
 CA2 — +5V  
 DA2 — +5V

AS2 — -D0\*  
 AR2 — -D1\*  
 AU2 — -D2\*  
 AT2 — -D3\*  
 AN2 — -D4\*  
 AP2 — -D5\*  
 AV2 — -D6\*  
 AM2 — -D7\*  
 AL2 — -D8\*  
 AK2 — -D9\*  
 AJ2 — -D10\*  
 AH1 — -D11\*  
 AH2 — -D12\*  
 AF2 — -D13\*  
 AF2 — -D14\*  
 AD2 — -D15\*  
 FE1 — -MSYN\*  
 FJ1 — -SSYN\*  
 FJ2 — -C0\*  
 FE2 — -C1\*

CH2 — -A0\*  
 CH1 — -A1\*  
 CF1 — -A2\*  
 CV2 — -A3\*  
 CU2 — -A4\*  
 CV1 — -A5\*  
 CU1 — -A6\*  
 CP2 — -A7\*  
 CN2 — -A8\*  
 CR1 — -A9\*  
 CP1 — -A10\*  
 CL1 — -A11\*  
 CC1 — -A12\*  
 CK2 — -A13\*  
 CK1 — -A14\*  
 CD2 — -A15\*  
 CE2 — -A16\*  
 CD1 — -A17\*  
 AP1 — -BOOT\*

AA1 — -NPG. IN\*  
 AB1 — -NPG. OUT\*  
 BU2 — -BR7\*  
 BE2 — -BR6\*  
 BE2 — -BR5\*  
 BH2 — -BR4\*  
 BL1 — -INIT\*  
 BK2 — -BG7. IN\*  
 BL2 — -BG7. OUT\*  
 BM2 — -BG6. IN\*  
 BM2 — -BG6. OUT\*  
 BP2 — -BG5. IN\*  
 BR2 — -BG5. OUT\*  
 BS2 — -BG4. IN\*  
 BT2 — -BG4. OUT\*  
 BR1 — -BBSY\*  
 BX1 — -NPR\*  
 BX1 — -INTR\*  
 BT2 — -SACK\*

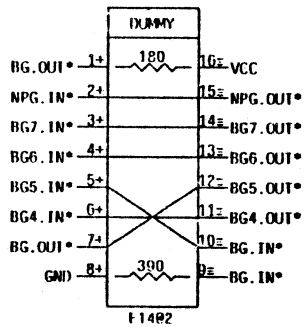
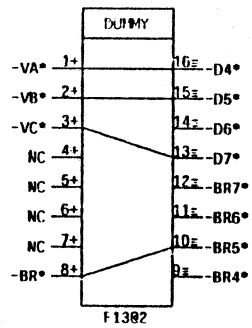

JUMPER SELECT FOR DESIRED RESULTS

