



**DIGITAL MAGNETIC TAPE
RECORDING FUNDAMENTALS**
Training Manual

SDS 900554A

DIGITAL MAGNETIC TAPE RECORDING FUNDAMENTALS

(Reproduced through the courtesy of
the Ampex Corporation)

AMPEX CORPORATION
SALES & SERVICE DIVISION
934 CHARTER STREET
REDWOOD CITY, CALIFORNIA

DIGITAL TECHNIQUES
PUBLICATION NUMBER 12

FIRST PRINTING AUGUST 1962

PREFACE

PREFACE

The need for a handbook of digital recording fundamentals has existed for a long time. Most texts have either failed to cover the subject of pulse recording or have given it inadequate attention. This is somewhat paradoxical in the face of the amount of detailed knowledge available. Much more is known about the basic pulse recording and reproducing process than is known about analog recording, e.g., direct. The references will give the reader a much more analytical and detailed explanation than is contained herein. However, the information included is intended to project the practical knowledge required in the everyday world.

This document is published for the first time, knowing full well that it is not perfect or complete in every detail. The probability of publication would be remote if we were to await the desired degree of perfection.

We are continually striving to raise the general level of our work and need your individual help to achieve this objective. The author is anxious to receive your comments regarding the general approach used. Specific criticism will be most beneficial in shaping the second edition which is to follow. Errors or omissions contained herein should also be brought to the attention of the writer.

C. A. Williamson
8/13/62

TABLE OF CONTENTS

Chapter 1	INTRODUCTION	Page 1
Chapter 2	TAPE	Page 6
Chapter 3	CODING	Page 14
Chapter 4	HEADS	Page 21
Chapter 5	WRITE & READ	Page 30
Chapter 6	FORMATS	Page 51
Chapter 7	ELECTRONICS	Not included in this edition
Chapter 8	PACKING DENSITY CONSIDERATIONS	Not included in this edition
Chapter 9	OTHER FACTORS	Not included in this edition

REFERENCES

Appendix I	BINARY ARITHMETIC AND NUMBERS
Appendix II	IBM TAPE SPECIFICATION

CHAPTER I

INTRODUCTION

The Ampex Corporation entered the digital field with the FR-200 tape transport in about 1956. Since that time Ampex has become a major supplier of digital tape memories--both domestically and internationally. Our success has been due, to large extent, to the technical ability of our field force and application engineers. This success has also contributed to a greatly expanded field force which has attracted many new individuals to Ampex. Many of them, although experts in some other field, are not familiar with digital tape memory systems. The purpose of this handbook is to bring the knowledge of these new engineers in line with current capabilities. It is also thought that this handbook can serve to summarize the knowledge of some of our "old-timers."

The continued success of Ampex depends upon the caliber of our technical people. The effective selling and servicing of digital tape memories requires individuals who possess a knowledge of the customer application and a fundamental understanding of digital magnetic tape recording concepts. This handbook has been largely devoted to magnetic tape recording concepts. There is one chapter devoted primarily to what might be termed application. This is the chapter on Tape Formats. Much of our effort is directed towards satisfying requirements involving tape formats of a specific computer. It is therefore required that we know what these format requirements are and how we satisfy them. At the time of this writing, this chapter contains only the IBM format. Others will be added during the revision periods scheduled for this work. It is felt that this will not present a serious limitation in that past experience has shown that the IBM 7-channel, one-half inch tape format constitutes about 80 percent of the requirements.

Before we begin our investigation of tape memories it may be beneficial for us to consider the needs which the digital tape memory satisfies. Magnetic tape memories have found an important place in the digital information processing industry. Other data storage mediums, such as punched cards or punched tape, are used to a certain extent. However, magnetic tape has certain advantages which places it far ahead of these "competitors." By far the greatest advantage is the high information transfer rate with which data can be transferred between the computer and the magnetic tape. An additional major advantage is that of high density information storage. An example of this is a 2,400-foot roll of one-half inch magnetic tape recorded at a character packing density

of 556 characters per inch. Such a roll of tape can contain more than 16 million 7-bit characters, while 200,000 punched cards or 133,000 feet of punched paper tape are required for the same amount of storage. It is therefore not difficult to see why magnetic tape is the principal medium by which information is loaded into or unloaded from a large-scale digital computer. Magnetic tape also serves as auxiliary storage of intermediate computation results or other data where long access times can be tolerated. Long in the sense used here is relative to the one to ten microseconds associated with the main computer memory. Magnetic tape is also used for long-term storage or for exchange of information between computers or other data handling systems. Recording (storage) of digital information on magnetic tape can be accomplished in many different ways. Several rather basic methods of writing information on a magnetic surface have been developed. These methods are discussed in greater detail in the chapters which deal with the coding and formatting of such information. While the chapter on codes in this handbook deals with the rather basic fundamental coding systems, there are many other more exotic methods, as well as basic method variations.

When computer information is to be recorded on magnetic tape, it usually takes the form of digits or characters. The information is usually referred to as characters when magnetic tape is involved. However, numerical information is sometimes referred to as digits. The magnetic characters can represent alpha-numeric coding, binary information, or symbolic codes used for print-out of computer information. The characters can be grouped together to form fixed or variable words. A fixed word always consists of a definite number of characters which constitute a fixed word. The IBM system is an example where six binary bits per character are grouped in 6-character increments to form the 36-bit computer word. The fixed or variable words can be recorded along the length of the tape forming fixed or variable blocks or records. A variable record length contains an indefinite number of characters limited only by the physical length of the tape involved. Computers designed around variable word and record lengths are usually more flexible than computers designed for fixed increments of information. However, variable word and record systems have a basic tape limitation. For example, the fixed word, fixed record system permits rewriting over existing information without growth of the record. Each block and each word is of a definite known length. This system is also fairly good from the standpoint of tape utilization, because generally the amount of tape upon which records are written is long compared to the total length consumed by inter-record gaps. In addition, fixed words make design of computers and their programming somewhat simpler, since a given-sized chunk of information is always used. Variable word, variable record systems have certain advantages too which have a bearing upon the handling of certain kinds of data. It is convenient to use this system which does not have rigid restrictions imposed upon a number of characters contained in either the word or a record. Payroll

records have varying amounts of information contained in them. For example, employees' names are not all the same length, hence variable words are very convenient in handling situations of this sort. Salaries, length of service, withholding tax, and all the other factors which relate to payroll deductions, etc., are also not of fixed length, since the content of various records differs tremendously from individual to individual. In this case, variable words and variable record lengths have a distinct advantage from the standpoint of tape utilization. If, however, many records are quite short, a large percentage of the tape might well be wasted in inter-record gaps. Short records are also wasteful from a standpoint of start/stop times required between records. To overcome this problem, variable words and variable record length systems allow the lumping of many records together to form long, composite records which then can be read in a single pass. (The same type of thing is sometimes done in fixed word, fixed block machines.) Several items may be combined in a single word by a procedure known as packing. However, more programming effort is needed in this case. Groups of words within the record constitute a field of information. A group of records on a tape constitutes a file, the same as a group of records on a given subject in the drawer of a filing cabinet constitutes a file. Hence, when customers speak of file of dating, master files, etc., they are really talking about a reel of tape and the information it contains.

Various buffering systems are used between the input/output equipment and the arithmetic unit of a computer. These buffers can be either magnetic cores flip-flops, or magnetic drums.

Since a large disparity exists between the transfer rate of information to or from a tape memory, and the speed of operation of the arithmetic unit itself, most computers are equipped with input/output buffers. These buffers are used to overcome some of the transfer rate problems associated with tape memories. Buffers are generally used as follows: A command to read a certain amount of information of a specific address is given by the computer to the tape transport controller; the tape control unit remembers this information and commences searching along a given tape for a particular address.

During this interval the computer is free to continue processing other information as programmed. When the tape unit has found the given address, the information is read from the tape memory into the input buffer where it is stored. When this operation is completed, the data is transferred to the main computer memory under control of the stored program. This data is processed by the central processor (arithmetic unit). Conversely, when the data is to be entered on the tape memory as a computer output, the information is normally transferred from the internal memory of the computer into the output buffer. The information is then read from the buffer and transmitted to the tape memory system.

Many early computers required that computations be terminated during transfer of information between the tape memory units and the internal computer memory. With the advent of machines during the mid-fifties, this problem was overcome and the tape memory information transfer can and does take place independent of the computer arithmetic unit.

Buffer size, record length and tape speed accuracy are in some ways inter-related. To illustrate this point, let us examine a typical computer operation. This operation will be known as file up-dating, wherein new information is added to certain records while certain other records contained within the file are re-recorded without processing. This is not like a straight duplication process where information is read directly from one tape and written upon another. Data is read, transferred, operated upon by the computer arithmetic unit, and then written on the output tape. The speed accuracies of the tape transport can cause the record length (in inches) to grow or shrink depending upon the transfer rate. For example, if tapes recorded at 45 kb/s at 150 ips are played back at 145 ips, the transfer rate is reduced to 43.5 kb/s. This lower transfer rate, if rewritten on a tape transport at 150 ips would result in an increased record length. Speed errors on the tape are a function of mechanical tolerances in the drive system, tape dimensional changes, and power line frequency variations. In order to overcome this problem, information is read from the tape memory into a buffer. When the buffer is one-half full, information is read out of the buffer at a regular clock rate which is timed mid-way between the minimum time of the anticipated input information. Such a buffer is called a sequential interlace buffer and finds frequent applications in digital data processing systems. The information is then processed by the computer arithmetic unit and is written on a new tape at the clock transfer rate. This results in bit packing densities which vary only a small amount because of tape speed error. Hence, the buffer in effect overcomes the speed error associated with the tape memory transport.

These and other considerations are examined in considerable detail in the chapters which follow. Before examining the tape memory in greater detail, the computer itself may be of some interest to us. Figure 1 illustrates a typical computer employing a variety of storage and display devices. It can be seen that storage devices with relatively high speed and low access times are connected directly to the central processing unit which contains the arithmetic unit. Devices with relatively long access times which include printers, card readers, card punchers, and magnetic tape units, are connected to buffering channels, which permits the transfer of information to and from the magnetic core storage at rates which are consistent with the arithmetic speed of the computer.

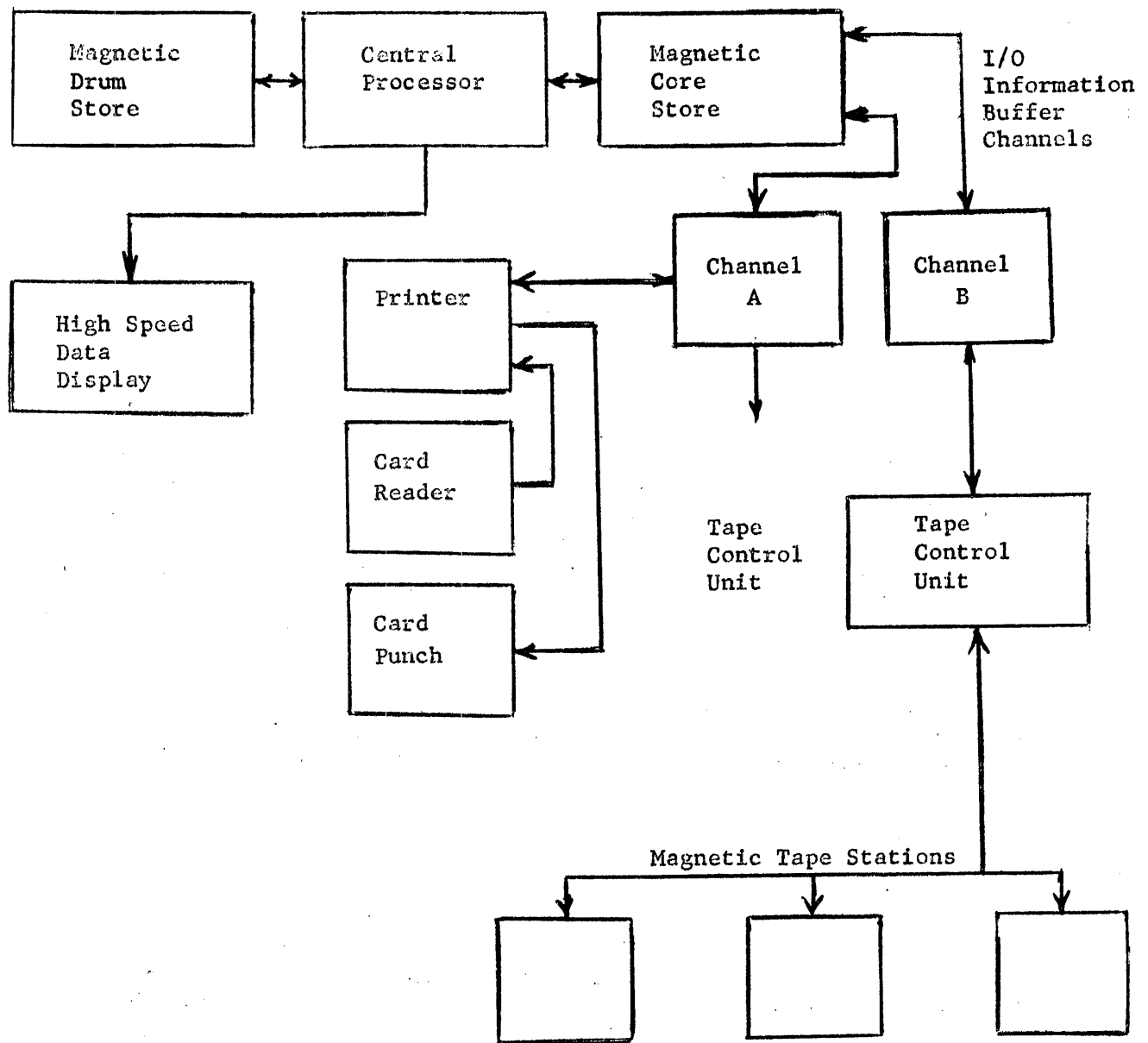

Figure 1

In the example illustrated, a single communication channel provides for printers, card readers and card punchers, as well as a number of tape units controlled by the tape unit controller. In addition, provision is made for direct access of the arithmetic unit to the magnetic drum units (slower than magnetic core but larger capacity). Access to high-speed data display units by the central processor has also been provided. Thus, a complete large scale computer has been outlined. The complete detailing of all of these blocks is beyond the scope of this paper. Rather, we will concern ourselves with the exchange of information between the computer and typical tape memory units. The reader is referred to current literature, wherein many of the blocks contained in Figure 1 are further amplified.

CHAPTER 2

MAGNETIC TAPE

INTRODUCTION

The recording of digital information on a magnetic surface can be accomplished in many different ways. Magnetic surface as used here refers to a surface with a depth dimension and not in the mathematical sense. The surface can be deposited upon a disk, cylinder or a narrow, pliable sheet of tape. The methods used to store information on these devices are very similar. The methods of magnetic tape recording are discussed in detail in succeeding chapters. The recording on drums or disks is beyond the scope of this work and the reader is referred to current literature for additional information on those devices. 1-2-8

Magnetic tape consists of thin sheets of plastic base material which has been coated with ferrous oxide particles. These oxide particles and their application to the base material are the subject of this chapter.

TAPE - Physical Characteristics and Manufacture ³

TAPE BACKING

The tape backing consists of the thin sheet of cellulose acetate or polyester film which is 6 to 12 inches wide when received from the manufacturer. These rolls of base material are referred to as webs. The thickness of the base material is normally .5, 1.0 or 1.5 mils before coating. The uncoated webs range in length from 600 to 7,200 feet. The physical characteristics of these materials are shown in Table 1.

TAPE COATING

It should be remembered that the base material is merely a support for the magnetic surface. The magnetic surface (coating) may be generally classified under the heading of magnetic oxide or binder material.

The most suitable magnetic material for tape coating is the acicular form of gamma ferric oxide (Fe_2O_3). It will have a particle length of .2 to .8 microns (1 micron = 10^{-6} meters or 39μ inches) and a width of 1/2 to 1/6 of its length; a specific gravity of 4.7 and a coercivity of approximately 260 oersteds. This is obtained from the basic raw material which is the alpha form of Fe_2O_3 .

CHARACTERISTICS OF TAPE BACKING MATERIALS

(Based on 1.5 mil, .25" wide tape)

	<u>Acetate</u>	<u>Polyester (Mylar*)</u>
Economy	Less expensive	More expensive
Uniformity of thickness	Excellent	Good
Tensile strength (yield)	5.6 lbs.	11 lbs.
Tear strength	4 grams	12/25 grams (.001/.015")
Mildew resistance	Low	High
Fungus resistance	Low	High
Coefficient of thermal expansion (70° - 120° F)	30 x 10 ⁻⁶ in./in.	15 x 10 ⁻⁶ in./in.
Coefficient of humidity expansion (20 - 92% R.H.)	150 x 10 ⁻⁶ in./in.	11 x 10 ⁻⁶ in./in.
Width tolerance	-.003 ± .001	-.003 ± .001
Length tolerance	-0 +30'	-0 +30'
Skew	- - -	.125"/96" max.

* T.M. DuPont

Table 1

The manufacturing process to obtain the end product is as follows:

1. Raw material - yellow ferrite (Fe₂O₃ H₂O) is dehydrated to αFe₂O₃. This is red, non-magnetic oxide.
2. Addition of hydrogen or carbon monoxide plus heat converts the αFe₂O₃ to Fe₃O₄ (black, magnetic ferrous ferric oxide).
3. Application of oxygen and heat (under closely controlled conditions) will produce the final gamma form of Fe₂O₃.

During the manufacture of the various oxides, extreme care is taken to produce a crystal of a particular size and shape. The crystal formation is due to the dehydration process. This process encourages to crystals to adhere, forming small masses. These masses are then separated into individual particles in a ball mill. Care is taken during the balling that no grinding takes place in order to prevent reduction of the particle size.

During the ball milling process the binders are added which consist of:

1. Binder - Cement that holds particles onto the backing.
2. Plasticizer - Gives flexibility to binder.

3. Wetting agent - Used to keep the Fe_2O_3 particles from re-combining.
4. Lubricant - Prevents the binder from adhering to the next layer of tape when wound on a reel.
5. Resin - Aid in dispersion of Fe_2O_3 particles and toughen coating.
6. Solvents - Enhances the binding between the coating and backing.
7. Anti-bloom agent - Prevents powder-like residue from forming on tape.

The ratio of oxide to binder generally is 60 to 40 percent. The particle size and uniformity determines to some extent the surface roughness of the tape coating, which is one of the contributing factors in high frequency resolution.

COATING AND POLISHING TECHNIQUES

There are three principle methods of applying the coating to the backing:

1. Knife or blade - Coating spread on tape.
2. Rotogravure - Coating applied to an engraved roller which deposits small beads of coating on backing which settle to a uniform thickness.
3. Reverse rollers - Controlled amount of coating poured on roller and deposited on backing.

In each case the thickness of the coating is closely maintained. Common thicknesses are .41 and .46 mils.

After backing is coated, the tape is then polished to remove the small needle-like projections caused by the particle shape. The four principle methods of accomplishing this are:

1. High-speed brushes of nylon or horsehair.
2. Buffing wheel.
3. Self-rubbing action.
4. Ferrosheening.

In the first three methods the protuberances are either ground down or pulled out. In the latter method these protuberances are flattened into the surface.

The final step in the manufacturing process is the slitting of the tape into specific widths.

MAGNETIC CHARACTERISTICS *

Before the description of magnetic tape memories is attempted, some basic terms and their meanings should be discussed. Reference is made to Figure 1 where a representative curve of magnetomotive force vs. flux is shown. Such curves are usually referred to as B-H curves.

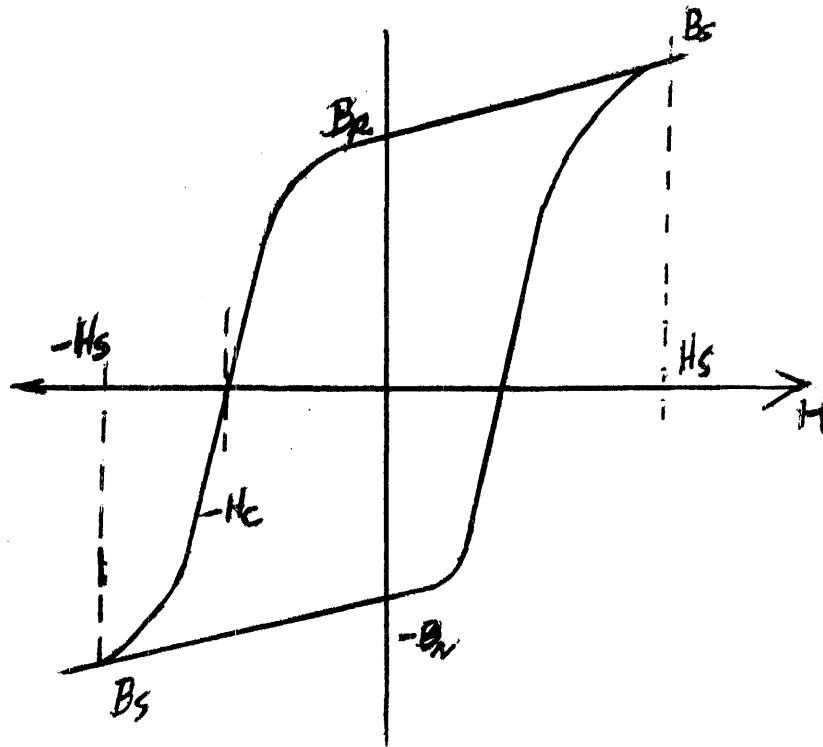

Figure 1

One of the most important specifications of magnetic tape is Intrinsic Coercivity (H_{ci}) which is a measurement of the force required to reduce the intrinsic induction of the magnetized surface to zero. The value (measured in oersteds) is an indication of the suitability of the material for tape memory applications. The value must be

* Definition and Explanation of Ampex
Computer Tape Specification 800-10-60

adjusted to provide operational performance of writing and ease of intentional erasure. The values shown in Table II represent an optimum balance of these requirements.

The Saturation Flux (ϕ_m) refers to the condition where a given cross-sectional area of tape is supporting the maximum number of lines of force.

Remanent Flux (ϕ_r) is that which remains in the same area after the energizing field is removed. This is an important specification in that it represents the signal-producing force which will be picked up by the read head.

Squareness Ratio is an indication of the efficiency of magnetic material. It is obtained by dividing the Remanent Flux by the Saturated Flux. Material with a Squareness Ratio of 1.0 would retain the saturated flux level after the signal field was removed. As the squareness ratio diminishes, a smaller part of the saturated level remains.

Retentivity (Br) is a measure of flux concentration. It is expressed in maxwells per square centimeter, or gauss, and is obtained from:

$$\frac{\text{Remanent Flux}}{\text{Surface thickness x tape width in sq. cm.}} = Br$$

Relative Output in db is an index figure for judging output levels using Ampex Standard Computer Tape as a zero reference. Measuring tests were conducted on a production model Ampex FR-307 digital tape handler. Read head voltage was measured across a 10,000 ohm load. A Hewlett-Packard 211-A Square Wave Generator was employed to supply the basic writing signal. The relationship of head output voltage is established allowing the adjustment of clipping levels as a function of the tape selected.

Output Uniformity is the maximum deviation in output voltage described above measured as employing a 200 bits per inch pulse packing density. The mean value of a thousand samples observed over a period of several months is taken as the center line.

The maximum output deviations have been set to fall within acceptable computer requirements. This insures that no clipping level readjustment will be required from reel to reel of the same basic type of Ampex computer tape.

Erasing Field is a recommended field which will reduce a saturated tape output signal to better than minus 60 db. Any remaining field below the minus 60 db will not activate any known electronics. For all practical purposes, minus 60 db represents a state of complete erasure.

The erasing field required is a function of loop squareness. The more square the loop, the greater the erasing field needed. H_{ci} represents the minimum field required for erasure. However, to assure complete erasure under all conditions, the minimum field advisable is increased by a factor of approximately four.

Resolution is a measure in microseconds indicating the pulse packing potential. Our figures are calculated as follows:

- a) Record (NRZ-M) a tape at 200 bit/inch.

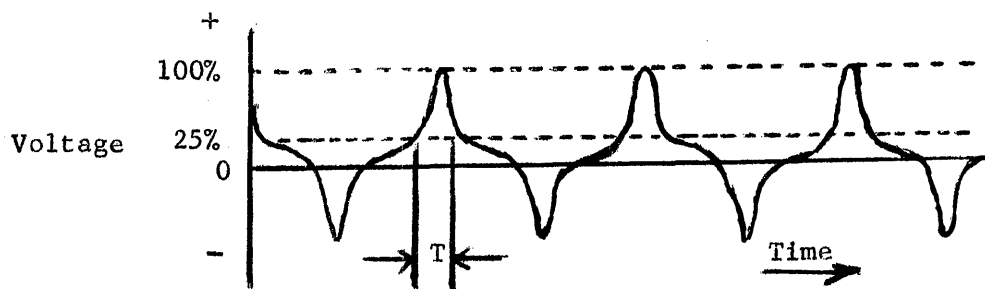

Figure 2

- b) Time (T) (from the read head output) is measured at the 25 percent level of maximum pulse amplitude and represents the time expired between the pulse rise and the pulse fall at the 25 percent level.

The smaller the T, the greater the pulse packing potential (PPP) of tape. The PPP of tape is in part a function of coating thickness. The thinner the coating, the greater the PPP. However, reduction of coating thickness is limited by the output level required and the desired wear characteristics, etc. The PPP of tape is also a function of oxide dispersion uniformity. Note: the figures given are to be used as an index only, since head configurations other than those on an Ampex FR-307 will provide figures in the area of plus 15 percent to minus 5 percent deviation from those stated in the specifications.

The Drop-out and Drop-in Frequency is a measure of tape suitability. This information is obtained by writing at saturation a series of flux reversals corresponding to the maximum packing density for which the tape is to be used. The tape is then read and the number of pulses (one pulse is associated with each flux reversal) which fail to exceed 50 percent amplitude of a nominal pulse are counted. Pulses which do not exceed 50 percent threshold clipping level are termed dropouts. Errors can also occur if the surface has imperfections where the magnetic material has been removed in some way. Detection of these is accomplished

by saturating the tape and looking for a read back voltage which exceeds 10 percent of the nominal voltage associated with a flux change. All Ampex Computer Tape is 100 percent tested as described above. Please note that the track width and spacing of the head used in the application must match the head used in testing for the guarantee to be valid.

Layer to Layer Signal Transfer is also known as print-thru. This characteristic is measured as per the following procedure:

- a) A completely erased tape is written to saturation at 200 bits per inch in one inch program blocks, with one and a half inch block spacing.
- b) The tape is conditioned under closely controlled environmental extremes for four hours.
- c) The block spacing is then read for program print-thru, and the resulting signal expressed as a percent of the original signal.

The print-thru on Ampex Computer Tape will never cause drop-ins as defined above.

The reader is referred to Appendix II wherein a typical tape specification is outlined. This specification concerns the tapes to be used on IBM 727 and 729 I through IV tape stations and is a copy of an official IBM specification. The original was received with several rolls of IBM tape early in 1961. This document is not necessarily current, but it is representative of such tape specifications.

		Long Wear High Output 833/843 Lo 836/846 Hi	Regular Wear Reg. Output 831/841 Lo 834/844 Hi	Long Wear Reg. Output 832/843 Lo 835/845 Hi	Remarks
Electro-Magnetic Properties					
Intrinsic Coercivity H_{ci}		262	258	254	Oersteds \pm 5% (Lines $\frac{1}{2}$ " tape) ϕ_m (Lines $\frac{1}{2}$ " tape) ϕ_r Ratio, Sq. = ϕ_r/ϕ_m Gauss, Br = ϕ_r/Area
Saturation Flux		2.1	1.7	1.6	
Remanent Flux		1.65	1.3	1.2	
Squareness Factor		0.78	0.76	0.75	
Retentivity Br		1290	1010	990	
Relative Output					Assume 831 @ 200 BPI as zero reference point, all others \pm in percentage from this. Measurements made on Ampex TM-2 system, 150 IPS.
200 bits/inch		+25	0	0	
600 bits/inch		+15	-8	-10	
Output Uniformity					When supplied \pm 5% reel to reel, the tape output varies no more than \pm 5% from the average of 100 bits read from the Ampex centerline tape.
Reel to Reel			\pm 10% or to Spec		
Within a Reel		\pm 3%	\pm 3%	\pm 3%	
Erase Field		800	700	700	Oersteds; strength of field to reduce a saturated tape output to -60 db, or better.
Resolution	Width	10.5	8	9	Microseconds; read pulse width at 25% of maximum amplitude, 150 IPS.
	Factor	.90	.92	.90	Ratio of 600 BPI output to 200 BPI output with standard Ampex TM-2 head and cable system, 150 IPS.
Zero Errors at	Density	Lo/Hi			An error is considered to be any bit whose read amplitude is 50% below normal, or any read noise spike from a saturated tape over 8% of normal signal. Normal acceptance is zero errors at 200 or 560 BPI, or to specification. Lo = 200 BPI; Hi = 556 BPI
Print Through		.45	.4	.5	% normal signal transferred to adjacent layer, 200 BPI saturated, 70F for 168hrs.

Table II

CHAPTER 3

CODING SYSTEMS

The storage of binary information on a magnetic surface can take many forms. The term "surface" as used herein refers to the thin film of magnetic material which has been in some way applied to a surface and not in the mathematical sense. The surface can be a cylindrical drum, a disk or a width of cellulose acetate or polyester film. The characteristics of the tape are discussed in the magnetic tape chapter of this handbook. One common element to all systems of magnetic information storage is that they all rely on differences in flux levels. That is, information is recorded in the form of flux levels, usually of opposite polarity at discreet points along the length of a track. At this point we will depart from the general subject and consider only those factors which influence the recording of information on magnetic tape. The reader is referred to current literature for information concerning drum and disk devices. 1-2-8

The writing and reading of information using a magnetic tape is accomplished by transducers called heads. The characteristics of these devices and their method of fabrication are dealt with in other chapters of this handbook. It is sufficient for our purpose here to say that a current which is caused to flow through a write head will in some way cause the tape to be magnetized. Likewise, a head to be used for reading will have a voltage induced in it as a function of the relative flux level and motion of the tape. The motion of the tape past the usually fixed reproduce head acts to scale the amplitude and width of the read pulse. 2

Any one of several basic techniques (or variations thereof) may be used for the storage of information. Some of these are discussed below.

RZ

The return to zero method of recording utilizes a tape which is in a magnetically neutral state as it approaches the write head. Ones and zeros have been assigned opposite flux polarities and a bit is recorded by applying current pulses through the write head. Short current pulses in one direction causing, say, positive tape saturation for a binary one and in the opposite direction for writing the flux necessary to represent a binary zero. Figure 1 illustrates this action, where IA indicates current through the head.

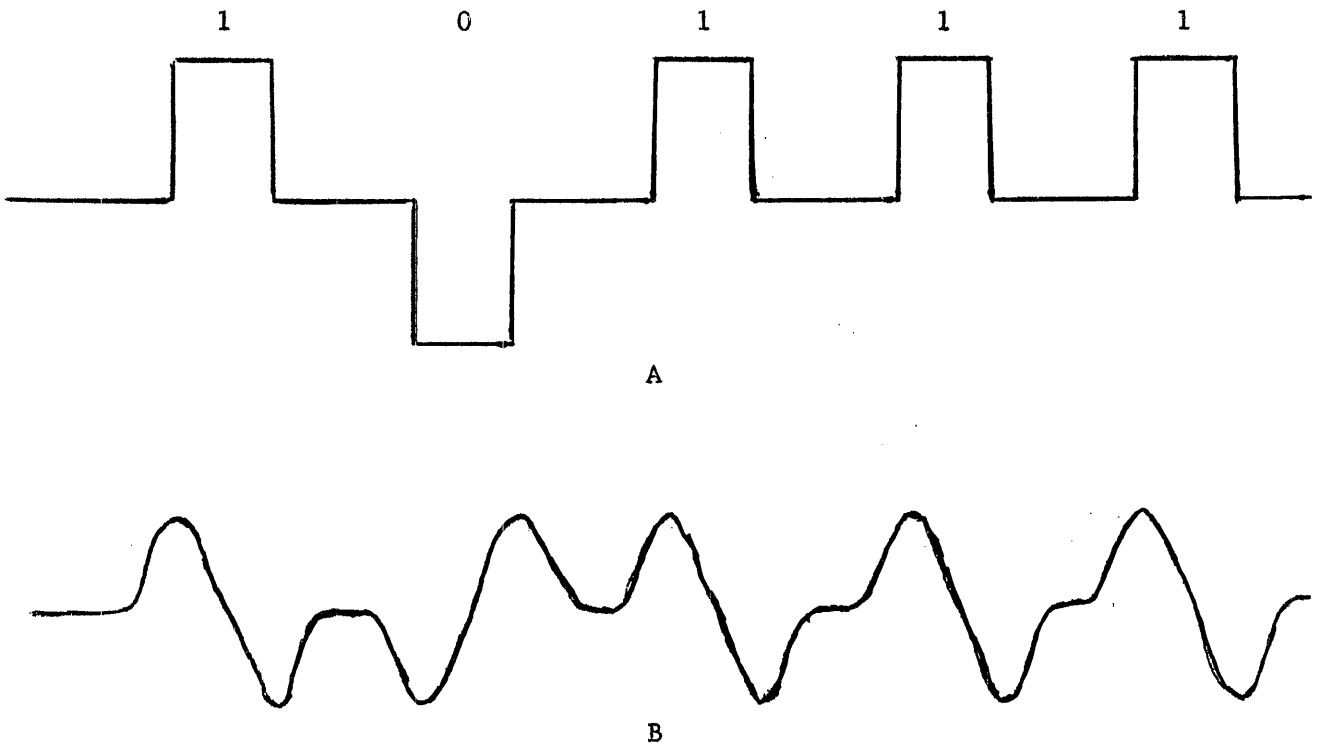

Figure 1

It also represents in a general way the flux on the tape. It can be seen that there is no current through the write head between bits and that flux returns to zero. The usual case will involve the movement of tape across the head during the write and read process. The write current rise and fall times are usually quite short, a microsecond or so, which result in sharp transitions of flux on the surface as a function of distance along the length of the tape. The bit packing density is then generally limited to the width of the pulse (drive current), the magnetic fringing effects of the write head, and the resolution of the tape and read head.

The voltage induced in the read head is shown in Figure 1B, where signal polarity differences can be observed between one and zero bits. In every case the signal rises positive before descending to a negative peak for a one bit where the opposite is true for a zero bit. This presumes a specific connection of the read head windings.

The recording of a pulse for each bit has the advantage that a lack of a read head signal is an obvious error. It is also easy to detect the read pulse at the right instant using relatively simple detectors to detect the amplitude and phase of the read head signal. In addition, a separation which lifts the recording medium away from either the write or read head will produce no error along the length of the medium. The disadvantages of the RZ system are that the medium must be erased prior

to writing, and a separation of the read head and medium will result in considerable loss of signal due to the short wave lengths involved. Little use has been made of the RZ system of recording in tape memories although it has the advantage of being self-clocking and does not require a DC connection to the driving circuit. This latter advantage has been considerably reduced by low voltage transistor circuits which are comparatively recent innovations. It is suggested that perhaps early workers in the field of magnetic recording thought that other coding systems offered higher information storage per unit of medium. Possibly this was true, considering the almost universal practice of using some method of amplitude detection. Later work has shown that this is not the case and there is little difference between RZ and NRZ read head pulse widths. There are two variations of the RZ system which have been used. One system uses the presence of a pulse to represent a one and the absence of a pulse to represent a zero. The disadvantage of this system is that only one-half of BH curve is being utilized. The other variation is referred to as RB recording, and since this system has been widely used, it will be discussed separately.

RB

RB, return to bias recording has been used in tape memories associated with the UNIVAC computer series of the Remington-Rand Corporation. This system uses a DC erase head located in the tape path just prior to the write head. The current through this head is adjusted such as to cause the tape to be saturated in one direction.

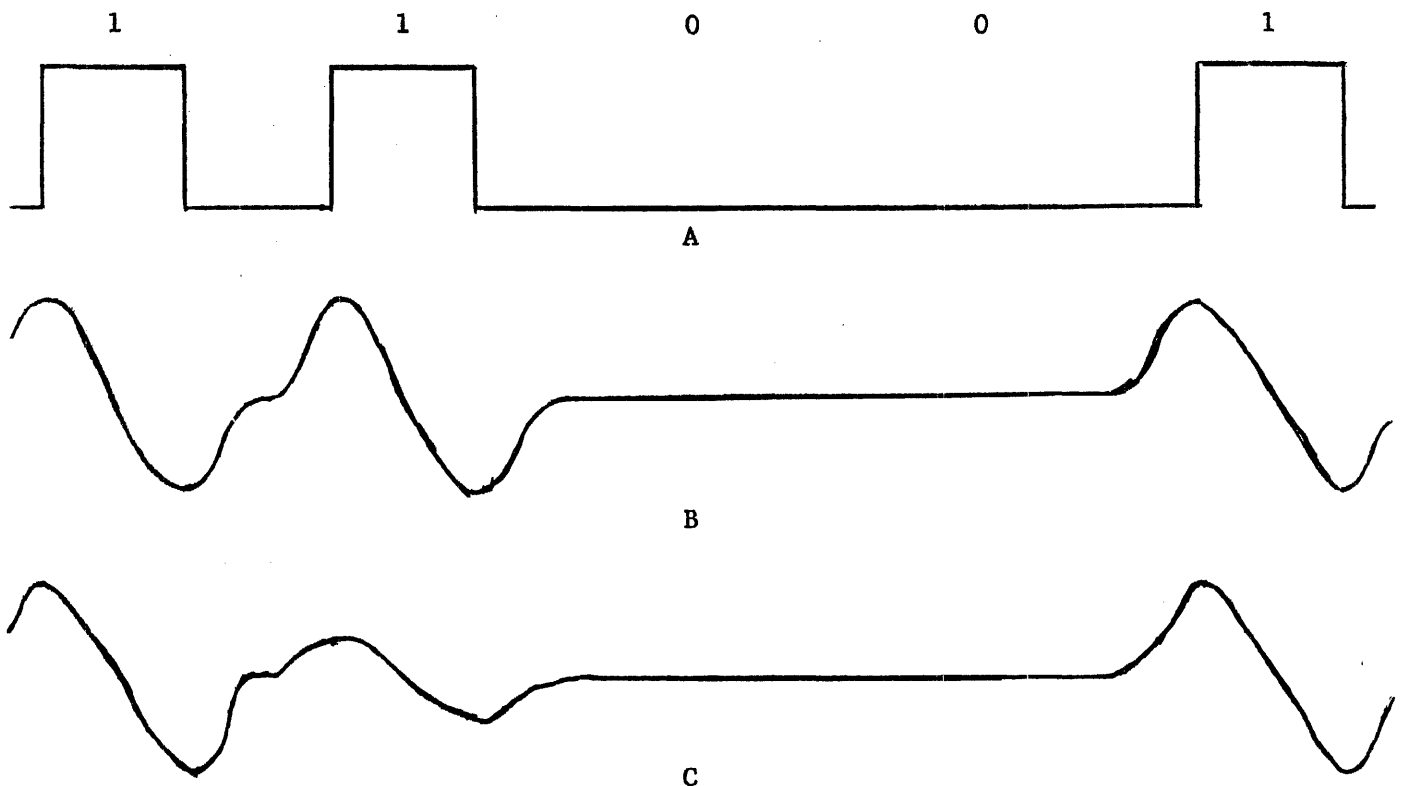

Figure 2

Binary information is then written by causing a pulse of current through a write head to switch the flux level on the tape to opposite state of saturation. This condition is maintained for a period of time, usually less than one-half the normal bit-to-bit distance. These transitions of flux from the biased condition are usually used to represent a binary one bit. Figure 2 illustrates this mode of recording. The only apparent advantage of this recording method over RZ is that the old information is erased. It offers no advantage over NRZ recording and has all the disadvantages.

NRZ

In NRZ recording a continuous current is passed through the write head resulting in the medium being magnetized to saturation at all times. Information is stored by means of write current reversals (flux) which take two general forms. One form is NRZ-Change, the other is NRZ-Mark (sometimes referred to as Inverted). These two basic NRZ variations are discussed in greater detail below. The advantages of NRZ recording are that separations of the medium from the heads produce less read amplitude drop than in the RZ system at low and medium packing densities. This results from the long, effective wave lengths at these densities. However, such separations during the write process produce pulse location shifts along the medium. Since the writing is done at saturation, the medium need not be erased prior to its use. It has been found that write current (or field) required to obliterate the previous magnetic history is approximately twice that which is required to saturate initially unmagnetized medium.

It has been assumed by some that NRZ recording is inherently capable of twice the information density of RZ recording because head current is switched once per bit (say from plus to minus) in NRZ and twice per bit (off-on and on-off) in RZ recording. The fallacy in this reasoning is apparent when one examines the reproduced pulse widths produced with both systems. The widths are very nearly identical; hence the packing densities obtainable are approximately the same. Some difference is observed when the record current is increased above saturation. The RZ pulse becomes wider than the NRZ pulse at the same record current. The major disadvantage of NRZ recording is that information may be in the form of an absence of a pulse. This necessitates some external means of determining when to sample a particular channel for the presence or absence of signal. On a multi-track tape machine, one or two tracks may be used as "clocks," with a reversal being recorded during every bit interval. When a pulse appears on the clock track(s), all other tracks are sampled. As all tracks must be read out simultaneously, inter-track errors caused by mechanical misalignments and differences in time of detection become very important, and will limit the packing density to a value which may be much lower than that determined by head resolution alone.

Another difficulty arises because it is impossible to discriminate between a lack of signal which is intentional and one which is caused by a dropout or other malfunction with simple detection schemes. Tape noise is at a maximum in NRZ recording because the medium is saturated in the intervals between pulses. NRZ recording has the highest power requirement of any recording method because full saturation current must flow in the record heads at all times during recording.

Non Return to Zero recording has been developed to a very high degree. Bit packing densities of 1,000 bits per inch are coming into use in instrumentation applications and at least one computer manufacturer has delivered systems where 800 bits per inch are used. Since there are two systems of NRZ recording, each will be discussed separately.

NRZ-CHANGE

NRZ-Change is a method of information storage wherein the flux level is caused to change only when the binary sequence changes from a zero to a one or from a one to a zero. Therefore, for a code of alternate ones and zeros (10101, etc.) the flux level will change once per bit. Figure 3 illustrates this condition and the read head output voltage which results. Detection of this information can be accomplished in a manner similar to that used in the RZ or RB system. A major drawback of NRZ-C recording is that caused by dropouts. Dropout being defined as a loss of signal during a flux transition.

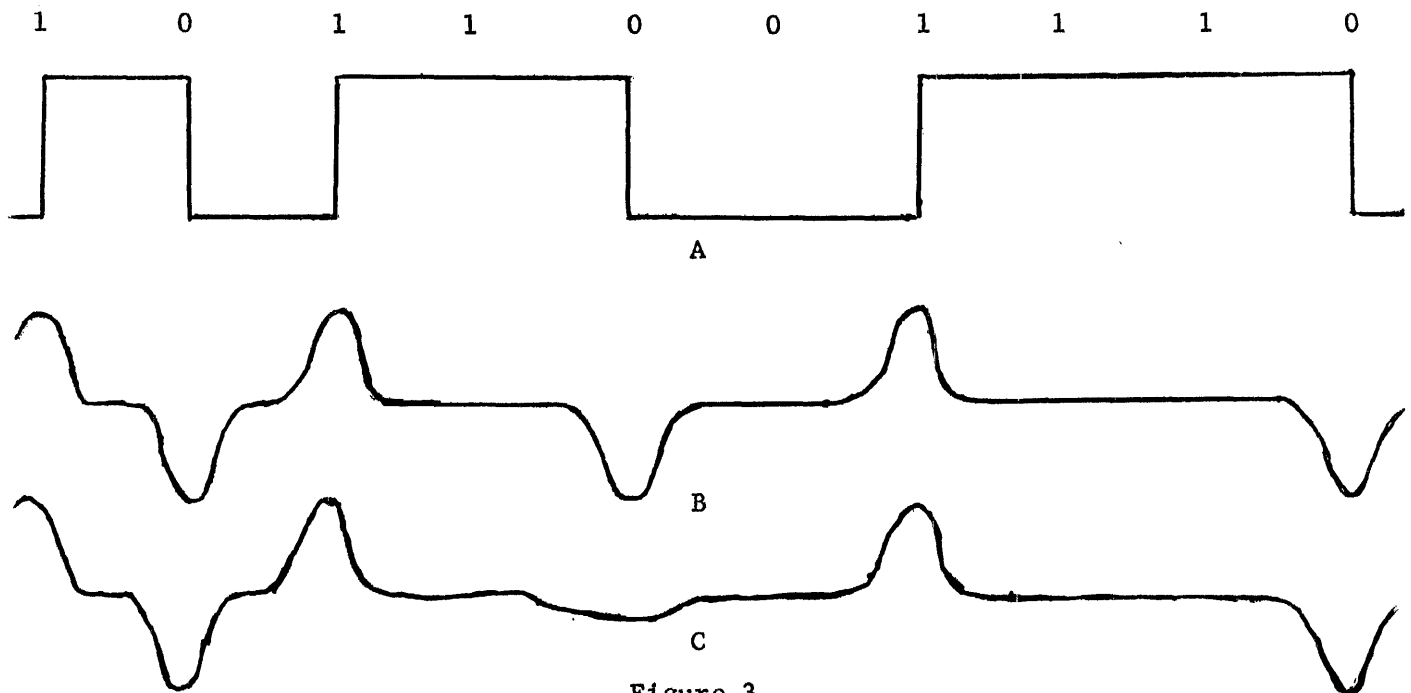

Figure 3

When this occurs and a flux transition fails to be detected, all bits of a given channel are erroneously detected until the next detected flux transition establishes the correct sequence (see Figure 3C).

NRZ-MARK

NRZ-Mark, or NRZ-Inverted as it is sometimes referred to, is a variation of the NRZ-C system. In the NRZ-M system the write head current causes the state of flux to be switched from one level of saturation to the opposite level each time a binary one is to be recorded. The absence of such a change is used to represent a binary zero.*

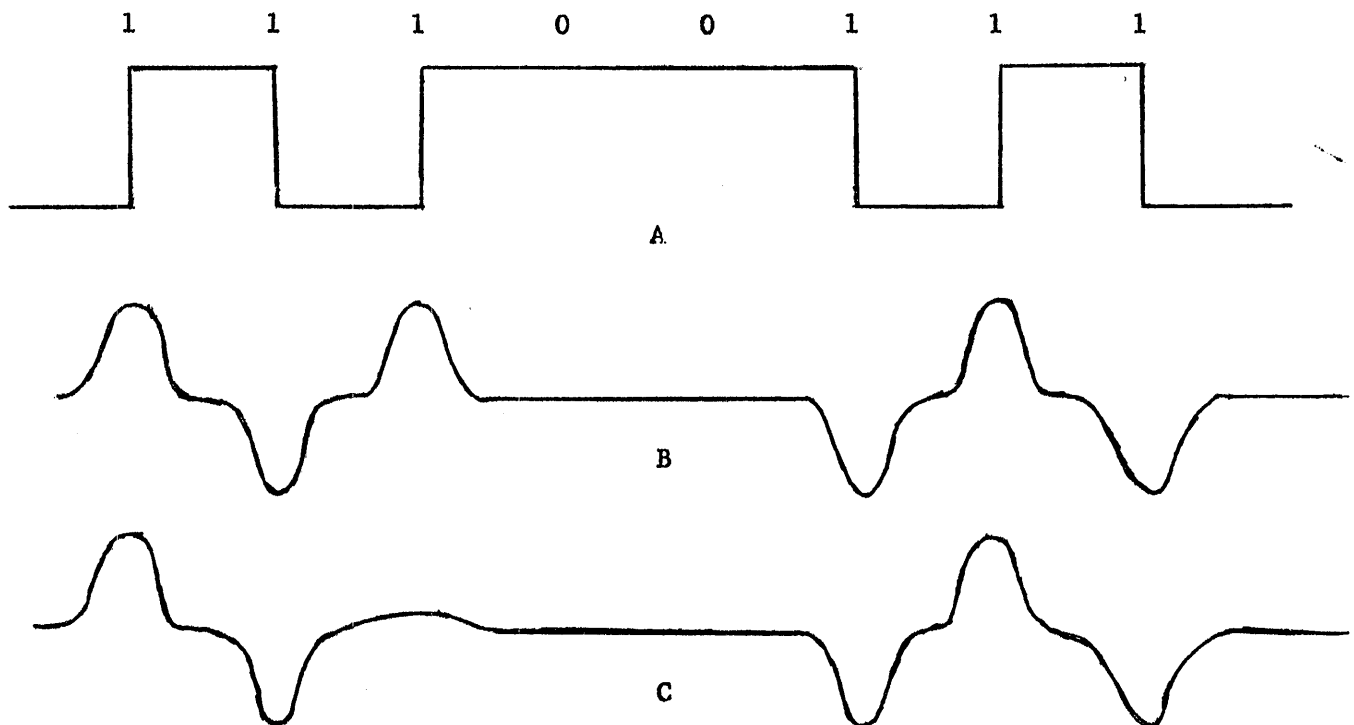

Figure 4

Figure 4 illustrates the NRZ-M system of recording where the voltage from the read head is shown. It can be noted that a dropout here (Figure 4C) affects only those bits where the amplitude drops below the detection level. All successive pulses are detected without error.

* In at least one system (Burroughs) a change of flux is used to represent a binary zero, and the absence of a flux change is used to represent a binary one. There appears to be no advantage to be gained or lost from this.

There are other more sophisticated systems of recording digital information. Most of these use variations of the recording processes already discussed. Since the use of these systems is limited at present, no discussion will be made at this time. The reader is referred to current literature for more information on these systems. 1-2-10

CHAPTER 4

HEADS

The write and read processes in digital tape memories are accomplished by transducers called heads. The write head process involves magnetization of the surface by causing a write current I_w to flow through a coil of wire wound around laminated pole pieces. Digital information is usually recorded by switching I_w so as to cause alternate flux states on the magnetic tape as described in the chapter which deals with information coding. The read process involves a voltage produced by a flux induced into laminated pole pieces by magnetic patterns on the tape as it moves past the head. Recently, there have been a number of heads developed which do not depend upon movement of the tape. These recent developments have not yet found wide acceptance and as such, are not included herein. In every case tape movement past the head is assumed in the description of the write and read processes.

Typical cut-away views of write and read heads are shown in Figure 1. Figure 1A illustrates a typical, symmetrical head assembly - so-called because of the symmetrical core construction. Figure 1B illustrates an asymmetrical head assembly which is more often encountered in digital tape memories in that two such heads can be mounted quite close together. One head is then used for writing, the other for reading. The read head is mounted downstream from the write head. A distance of .25 to .40 inches write gap to read gap is typical for these assemblies.

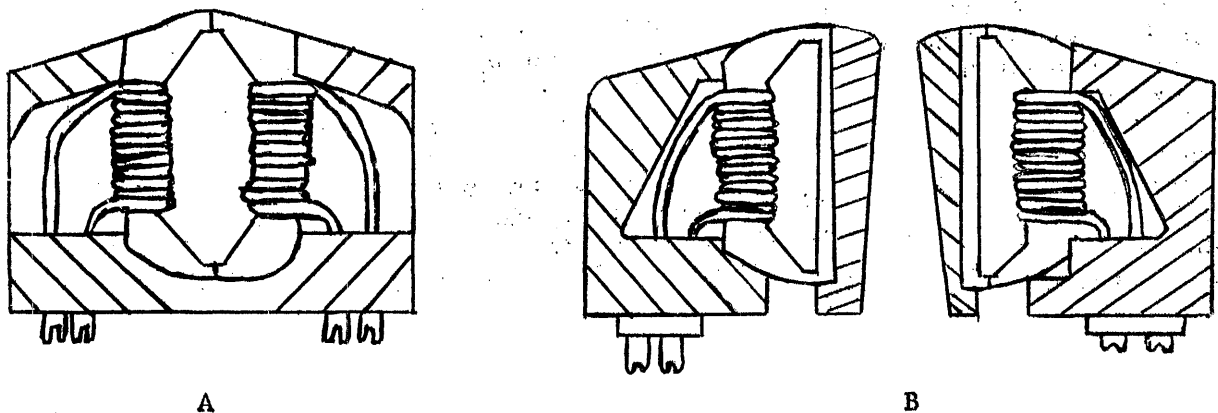

FIGURE 1

The material used to form the core is some form of mopermalloy, laminated from pieces two to ten thousandths thick. Insulating material is inserted between the individual laminations and is cemented in place. This precludes the use of some types of fluids for head cleaning purposes. Failure to follow instruction book recommendations can result in destruction of the head through improper use.

The cores (pole pieces) are wound with from 25 to 600 turns per core depending upon the intended application of the finished head assembly. Requirement for a sufficient number of turns must always be balanced against the space available and the inductance of the finished head. The core assembly, after it is wound with the correct number of turns, is assembled together with other cores to form a multi-track magnetic head assembly. The number of tracks varies with the application; however, 7 or 8 tracks on $\frac{1}{2}$ inch; 11, 12, or 16 tracks on $\frac{3}{4}$ inch; and 16, 20, or 21 tracks on 1 inch, are typical for digital tape memories.

STATIC SKEW:

Static skew is one of the most important specification considerations for digital magnetic tape memories. Static skew results from the accumulation of mechanical tolerances associated with the manufacture of magnetic read and write head assemblies, and the elements which control the tape as it passes over the head assembly. Static skew is an undersirable error. If it is allowed to become large, as compared to the desired bit to bit spacing, it will have a serious effect upon the maximum information storage capacity of the system (BPI). Static skew can be compensated for in the signal electronics associated with the read and write heads. The compensation required will be reduced if reasonable care is taken during the manufacture to retain a high established level of precision.

Static skew results from four major areas associated with the processes utilized in magnetic head manufacture. These are gap scatter, D_g , azimuth, D_z , Base plate flatness D_b , and guide height D_{gh} . Referring to Figure 2, it can be seen that the gaps of a 7-channel head shown are contained within two parallel lines. It should be pointed out that the gap length (distance which separates the pole pieces) is usually much larger than the gap scatter D_g , and is usually short as shown in Figure 2. Gap scatter variations of 100 to 200 microinches are typical while dimensions of 250 to 750 microinches are more usually associated with the pole piece gap length. No consideration is made regarding azimuth or other factors when making gap scatter measurements.

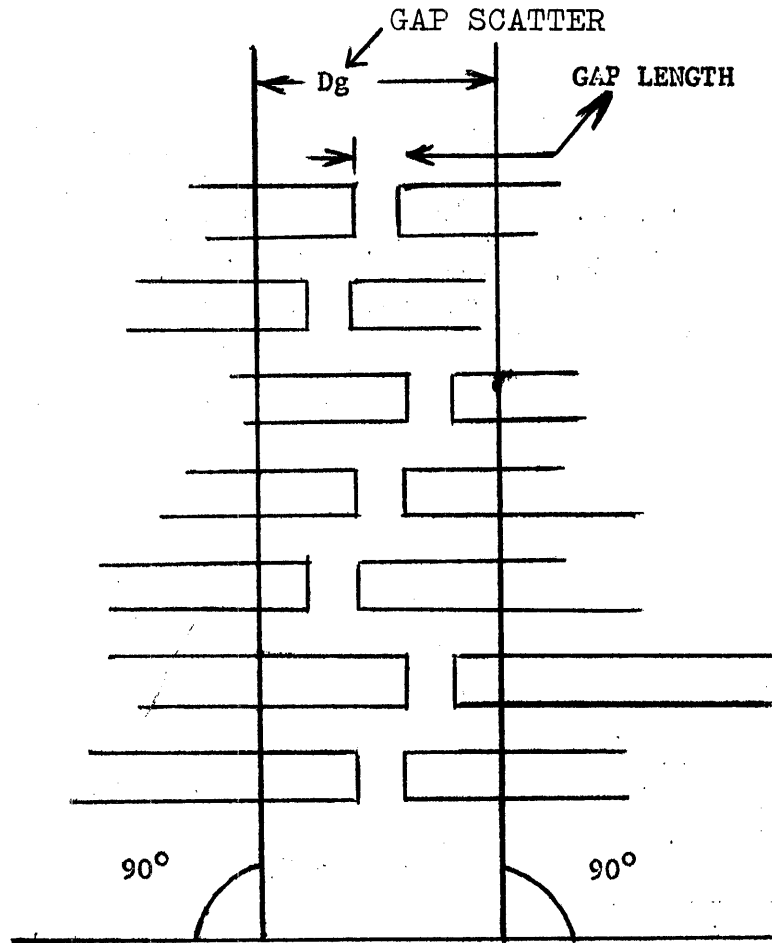

FIGURE 2

Gap azimuth refers to angular variations from 90° which the gaps have assumed when mounted on the base plate. At Ampex, unmounted heads have no azimuth specifications. It is not until they are mounted on a base plate that the azimuth variation from 90° takes on significance. Gap azimuth is a line of mean dispersion drawn through the center of the trailing pole pieces of the outside tracks (write head only). The center of the gap length is used for reproduce heads. Referring to Figure 3, it can be seen that a line has been drawn through the center of tracks one and seven and that the remaining tracks are staggered about this line.

Figure 4 illustrates a condition where track 6 is shown to be displaced from both tracks 1 and 7 by the gap scatter D_g . In this case, tracks 1 and 7 are shown to be on a line oriented $+1'$ from 90° . Therefore, the total displacement (worst case) between trailing edges exists between tracks 1 and 6. This condition can also exist for a read head with proper consideration being made for measurements at the center of the gap lengths. Gap azimuth is specified as \pm variations of one minute from 90 degrees.

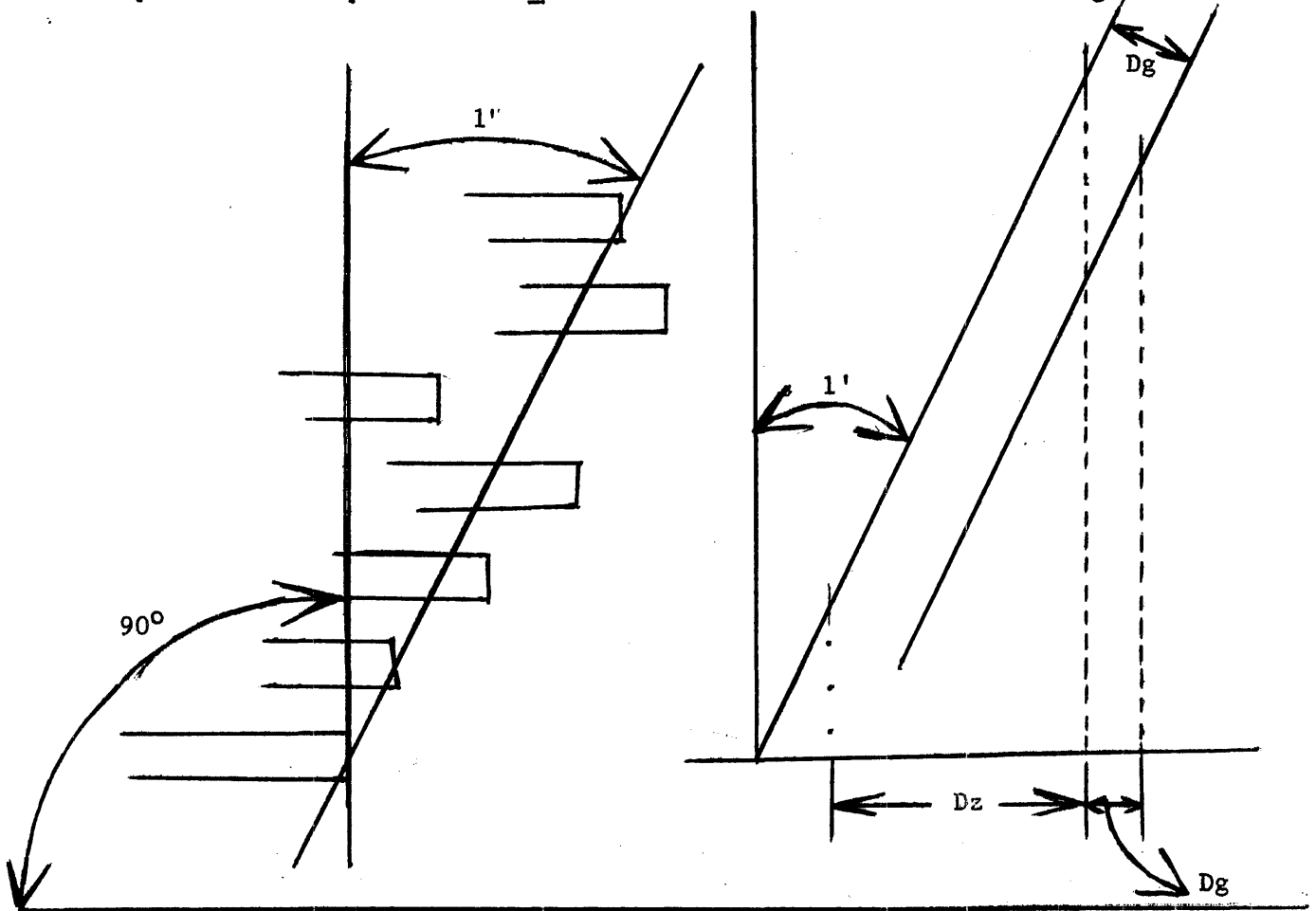

Figure 3

Figure 4

A gap scatter condition as shown in Figure 4 can also exist on read so a total read/write static skew due to gap scatter and gap azimuth results from the sum of the write gap scatter plus write azimuth plus read gap scatter plus read azimuth as shown by equation 1.

$$\frac{W}{D_g} + \frac{W}{D_z} + \frac{R}{D_g} + \frac{R}{D_z} = \text{Total Error (1)}$$

To the gap scatter and azimuth variations must be added the effects caused by tape guiding. There is a flatness tolerance associated with the base plate. In addition there is a tolerance assigned to the amount of taper which may exist from one end of the base plate to the other. The taper does not cause further aggravation of the gap azimuth error. This is due to final measurements being made after the head stack is assembled on the base plate. Referring to Figure 5, it can be observed that there are two guides upon which the upper edge of the tape rides. These guides have variation of taper from nominal.

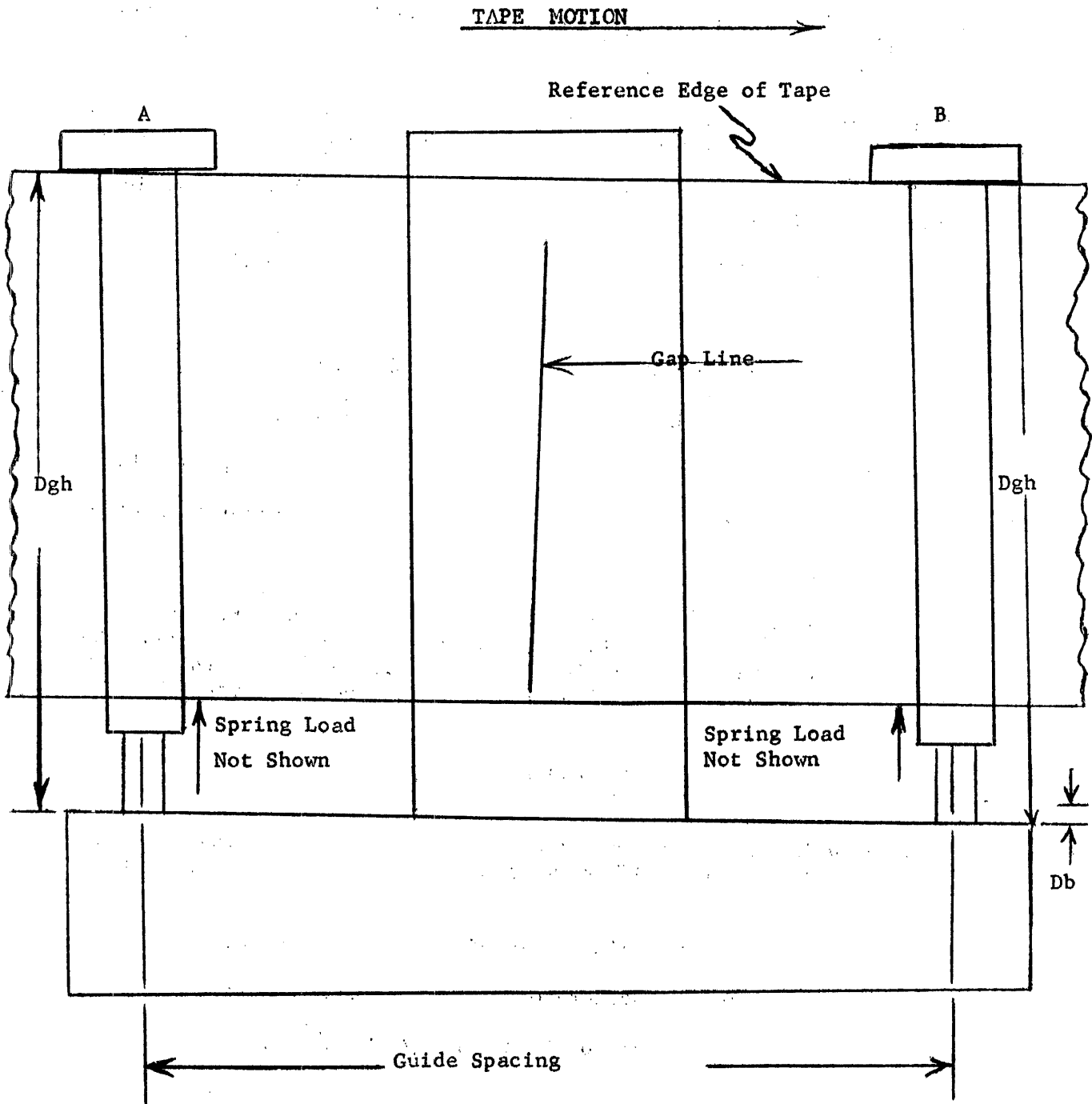

FIGURE 5

It is then possible that guide A may be high by the maximum amount and that guide B may be low by the maximum amount. These guides are mounted on a base plate which can be tapered by an amount defined by the difference in thickness between that at point A and at point B. The total error associated with the guide height and base plate taper tolerance is in the difference between the height of guide A with respect to guide B divided by the distance between guides (1" tape). To obtain the maximum static skew for a given head assembly, then the total gap scatter and azimuth error must be added to the guiding error.

A sample solution utilizing typical tolerances associated with magnetic tape memory heads is included to further illustrate these considerations.

Given a 7-channel asymmetrical TM-2 head assembly with the following tolerances (reference Figure 5):

Gap Scatter Dg	=	100 micro inches
Gap Azimuth Dg	=	$\pm 1'$ arc
Base Plate Taper Db	=	200 micro inches/inch
Guide Height Dgh	=	.87505/,.87495
Track Width	=	48 mils Write, 30 mils Read
Track Spacing	=	70 mils center to center

CHART I

The first step in obtaining total static skew is to convert the azimuth tolerance to inches so that it can be considered with the others. Converting angular dimension to linear distance along the length of that tape is accomplished by equation #2 as illustrated in Figure 6.

$$D = \frac{\sin \phi}{z} D \quad (2)$$

Dimension D is the center-to-center distance of the two outside tracks and is .420 inches (6 X .070 = .420) using the typical specifications outlined above.

Da = Azimuth gap dispersion in inches.

D = Center-to-center distance of outside track.

ϕ = sin of 1' of arc (29 X 10⁻⁵).

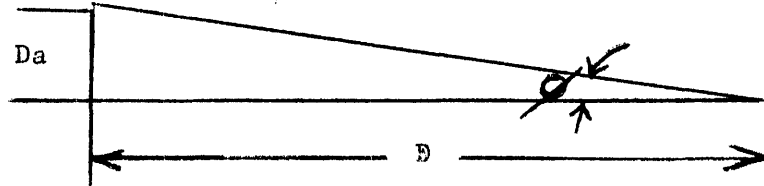

Figure 6

Solving for D_a then

$$.42 \times 29 \times 10^{-5} = 12.18 \times 10^{-5} \text{ inches}$$

Which applies equally to both the read and write heads. Since the tolerance is specified \pm the write head can be in the worst case opposite to the read head. Referring the Figure 4 it can be seen that in worst cases the gap scatter D_g can be added to the maximum azimuth error D_z . In this case this results in

$$120 \times 10^{-6} + 100 \times 10^{-6} = 240 \times 10^{-6} \text{ inches}$$

240 microinches. It should be remembered that the azimuth error was specified as \pm . The gap scatter is specified as 100 microinches maximum for any head. Therefore, if worst case write/read azimuth exists it is possible for the gap scatter to add to this in both the write and read heads so the R/W sum becomes (reference equation #1)

$$120 + 100 + 120 + 100 = 440 \text{ microinches.}$$

The elements which exert the major influence over the tape as it passes over the R/W heads are the head base plate and tape guides. Referring to Figure 5 it can be seen that the tape is traveling downhill in the direction of point B. Now assume worst case condition of the base taper at point B to result in a height difference from point A as specified above (200 microinches/inch) and for the guide at point A to be .87505 inch and the guide at point B to be .87495 inch.

Then the difference in base height between point A and point B becomes 200 microinch multiplied by the distance between the points (3 inches)

or 600 microinches/inch. Since the guide at point A is 100 microinches (.87505 - .87495) higher than the guide at point B the total downhill tape movement results in 700 microinch/inch of dispersion across 3 inches. This is simply illustrated in Figure 7

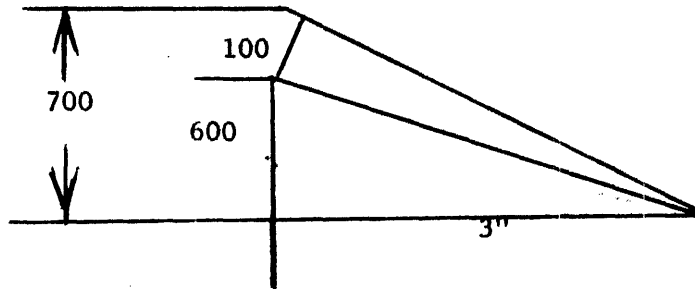

Figure 7

Now, since we are using $\frac{1}{2}$ inch tape and guides 3 inches apart, this error is reduced by the distance between the guides divided by $\frac{1}{2}$, or

$$\frac{700}{3} = 233 \text{ microinch/inch}$$

$$\frac{233}{2} = 166 \text{ microinch}/\frac{1}{2} \text{ inch}$$

the opposite situation could exist on the read head so the R/W error is twice the error above.

STATIC SKEW, WORST CASE

	<u>Write</u>	<u>Read</u>	<u>Total</u>
Gap Scatter	100	100	200
Azimuth ($\pm 1'$)	120	120	240
Base Plate Taper (± 6)	100	100	200
Guide Height Difference (± 6)	<u>16</u>	<u>16</u>	<u>32</u>
	336	336	672

CHART II

SIGNAL ELECTRONICS

STATIC SKEW

TAPE GUIDES & BASE

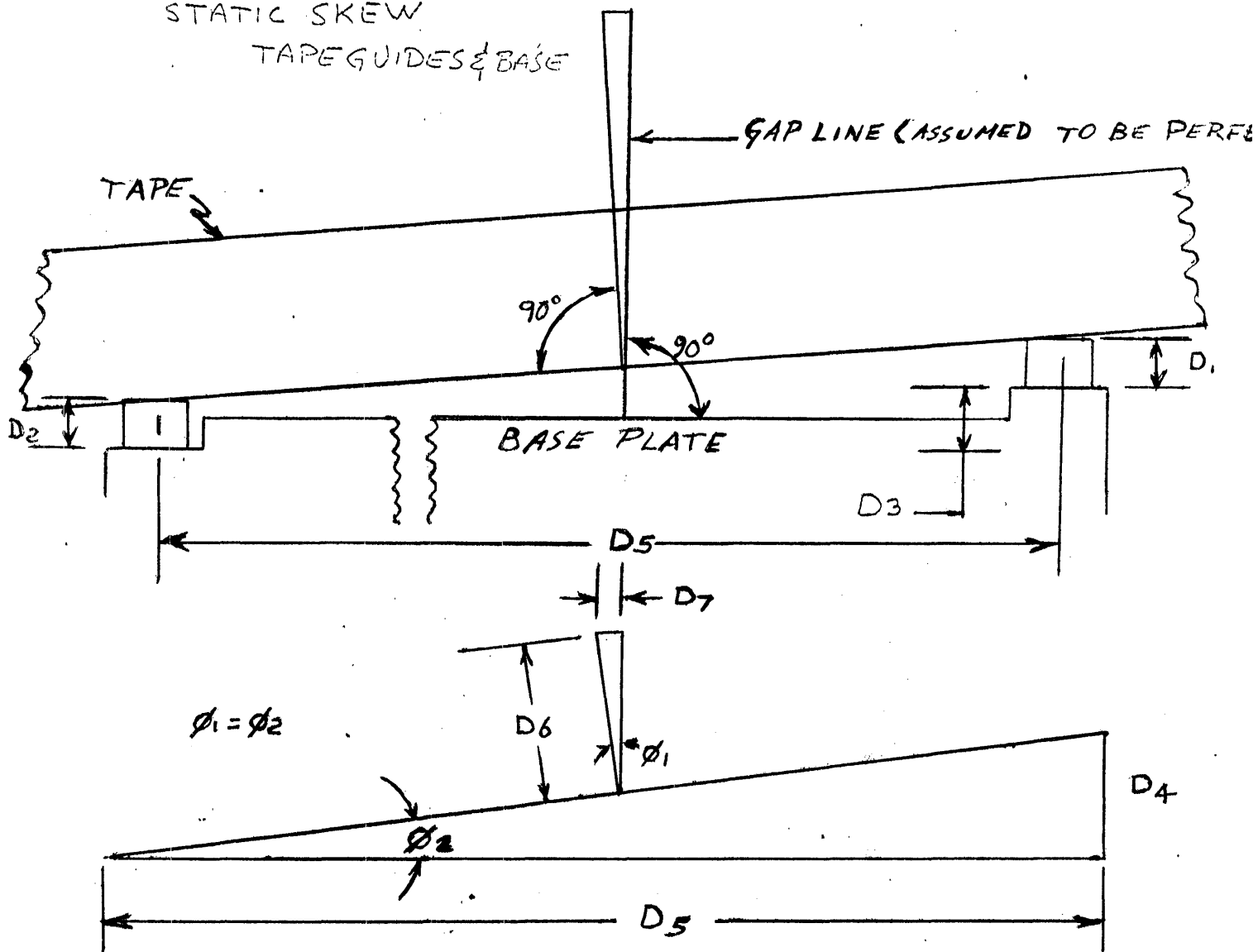

LET $D_1 = \text{MAX. GUIDE SIZE}$

LET $D_2 = \text{MIN. GUIDE SIZE}$

LET $D_3 = \text{BASE PLATE SURFACE FLATNESS}$

THEN:

$$D_4 = D_1 - D_2 + D_3 \quad (\text{WORST CASE})$$

LET $D_5 = \text{CENTER TO CENTER DISTANCE OF GUIDES}$

LET $D_6 = \text{CENTER-TO-CENTER DISTANCE OF EDGE TRACKS}$

THEN:

$$D_7 = \frac{D_4}{D_5} D_6$$

AS $\tan \theta_2 = \frac{D_4}{D_5}$ AND $\tan \theta_2 = \sin \theta_1$, FOR ANGLES OF 59' OR LESS (TO AN ACCURACY OF 1 PART IN 10⁵)

Chart II summarizes the errors for write and read heads mounted on different tape transports and represent worst case conditions. A similar example can be drawn for a 1-inch head with proper considerations given for the increased tape dimension.

CHAPTER 5

WRITE/READ PROCESSES

The purpose of a digital tape memory system is the storage of information for retrieval at some later time. This fact may have become somewhat obscured in the preceding chapters where the tape, heads, and coding systems were discussed. The intent here is to pull together all of this inter-related material so that an understanding of tape memory fundamentals can be developed. At the same time, we will also introduce a new element--the tape transport mechanism. The mechanics of the record/reproduce processes (herein called write and read) are examined in greater detail, in particular the head to medium relationship.

A typical channel of a tape memory is illustrated in Figure 1. For the purposes of illustration, this single channel will be considered as a system, although many such channels make up a typical multi-channel tape memory.

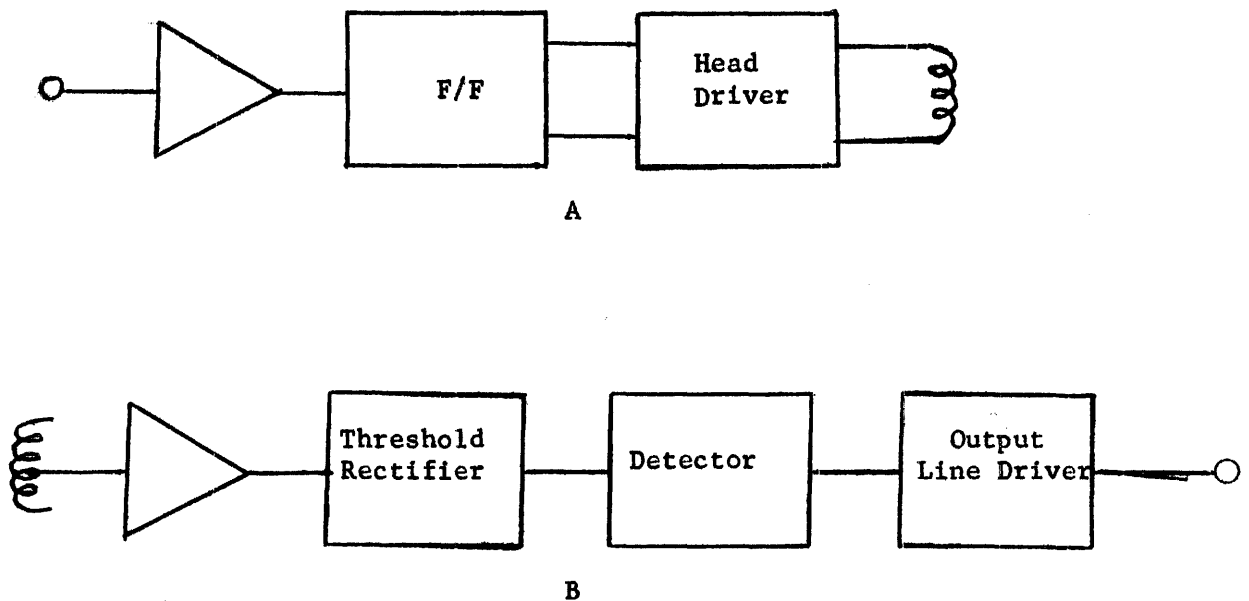

Figure 1

Figure 1A shows the basic fundamental elements of a NRZ-M write channel. The use of NRZ-M coding has been assumed because of its predominance in the field of magnetic tape information storage. Other coding systems such as RZ, RB and NRZ-C are in limited use, but their frequency of use

does not begin to approach that of the NRZ-M system. These other systems will not be discussed here, as such; however, many of the considerations of NRZ-M coding will apply equally to these other methods of coding. Figure 1B illustrates the read part of the system with the magnetic tape presumed to pass over the write and read heads shown schematically as solenoids.

The point where the customer connects to our system terminals is referred to as an "interface." Specification parameters such as voltage amplitude and polarity, source and load impedances, shunt capacity, and rise and fall times are associated with this electrical interface.

WRITE SYSTEM

The write system includes electronics, the magnetic write head and the tape. The electronics associated with this function are used to condition customer-supplied signals such that they are suitable for application to a write head. These signals, when applied to a write head, cause magnetic flux patterns to be impressed on the moving tape. These were discussed in the chapter which dealt with storage coding methods. At this time we are continuing to assume tape movement past the head, but are not specifying its velocity or the consistency of its movement.

The input amplifier is included to accept the customer's signals (usually fast rise positive or negative pulses or level transitions) and shape them for application to the NRZ-M flip-flop. The NRZ-M flip-flop is usually referred to as an NRZ Register in a multi-channel system. Both F/F outputs are shown connected to the Head Driver. It may be that only one is used in some systems. The F/F output is used to control the opening and closing of switches contained in the Head Driver. These switches in conjunction with system power supplies control the direction of current through the head. The switching of current direction causes the magnetic flux patterns generated on the moving tape to switch polarity; thus, information is written on the tape. In the NRZ-M system assumed here, the presence of a customer-supplied pulse can represent a binary one and the absence of a pulse a binary zero. Such a situation is illustrated in Figure 2 where a binary 11101101 sequence is shown.

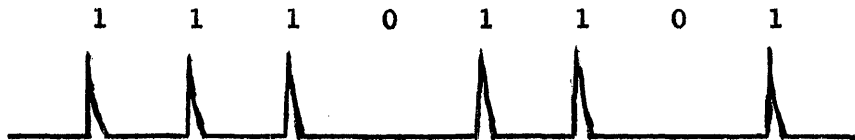
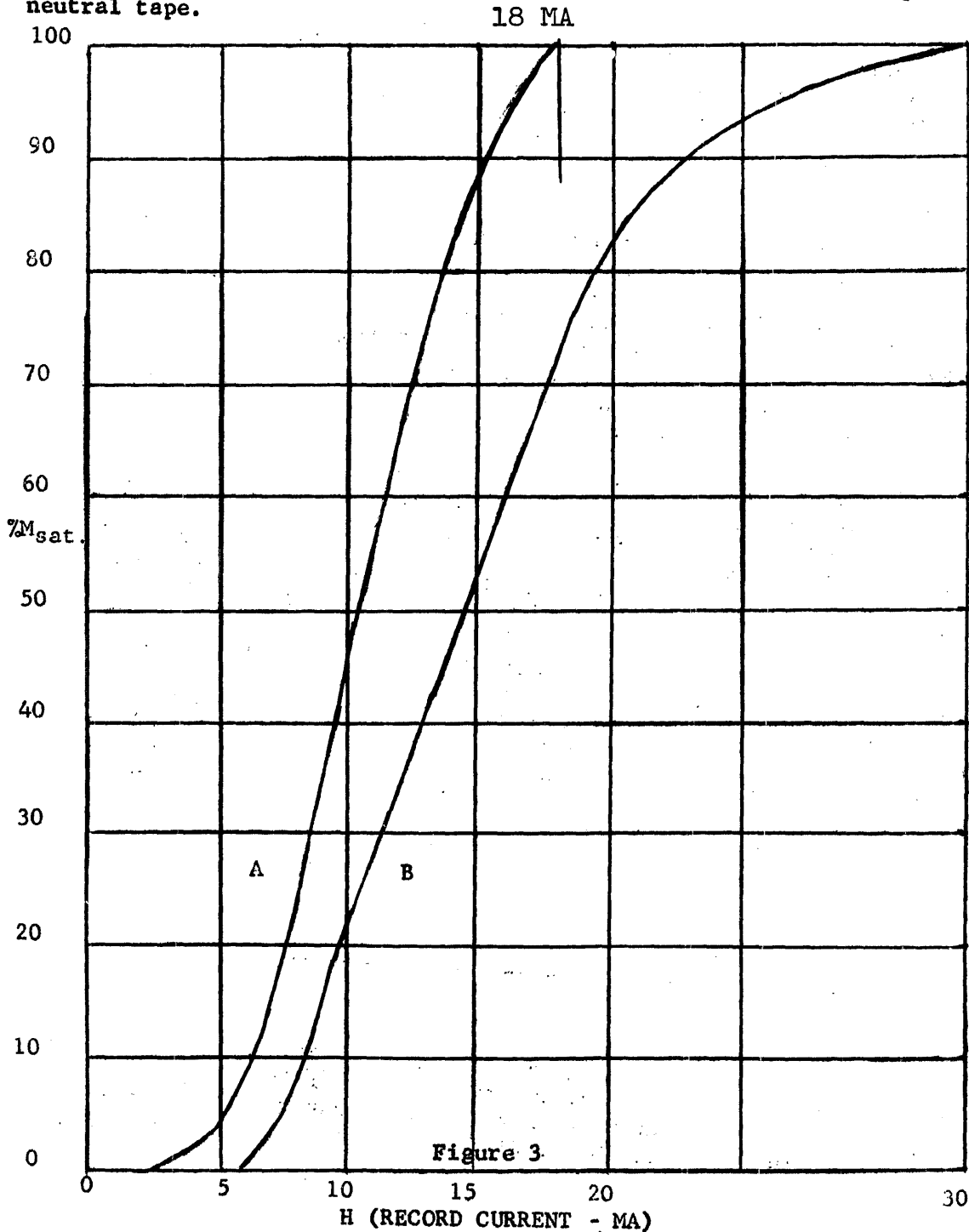

Figure 2

When a current is passed through a write head, a flux field is set up which will cause the tape to become magnetized. This magnetization M as a percentage of M saturation is plotted against H (in ma for a typical head) in Figure 3. Here, Figure 3A represents the condition

where magnetically neutral tape is magnetized for the first time. Figure 3B illustrates the condition where a previous magnetic history (equal to, and of opposite polarity) existed before application of the values of H plotted. The H or record current required to saturate the magnetic tape in the presence of existing remanent flux of opposite saturated polarity is shown to be 1.5 times that required for magnetically neutral tape.



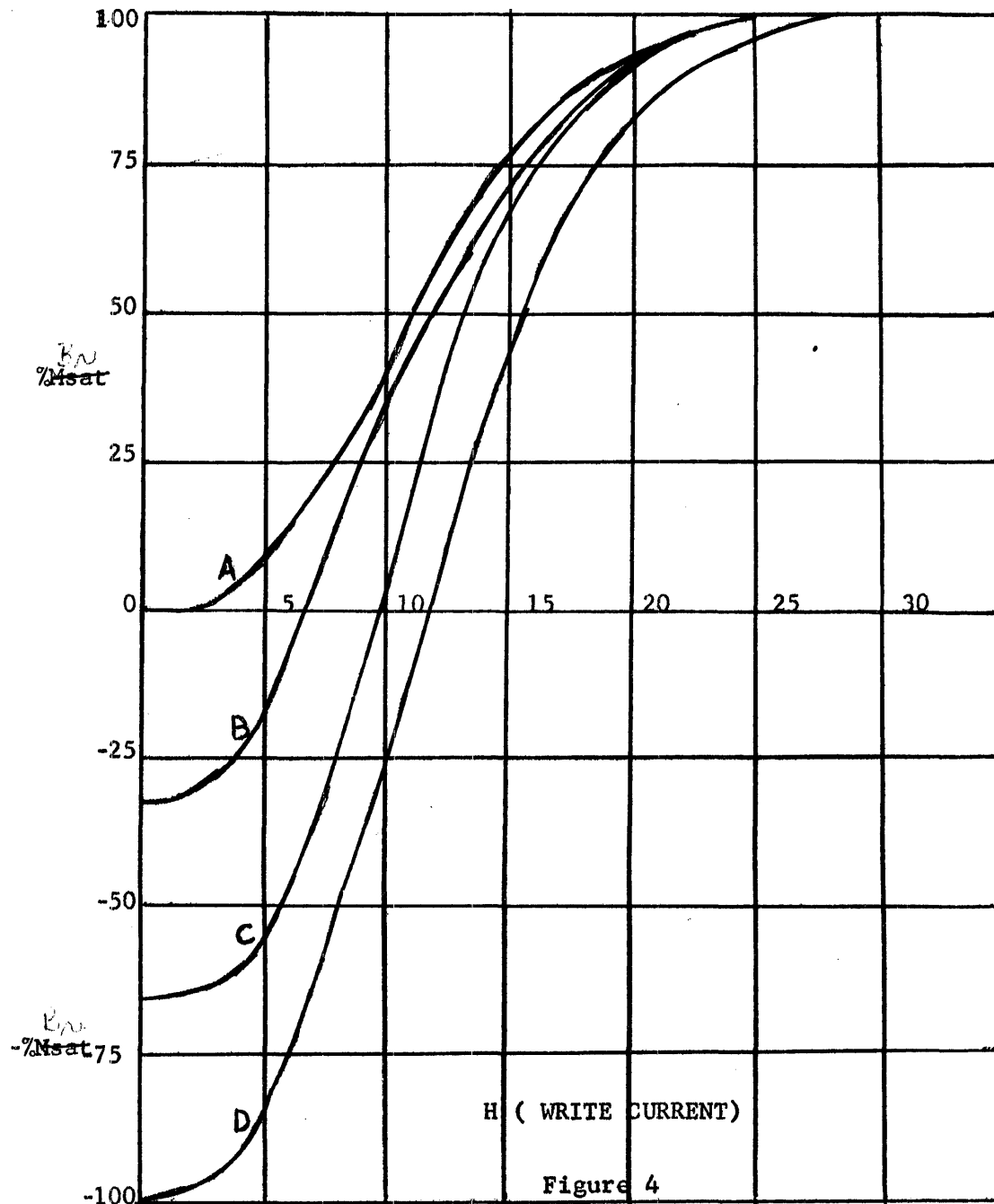

Figure 4 illustrates the switching of flux from one polarity to the other. Figure 4A represents magnetically neutral tape. Figure 4B, C and D represent the switching to saturation from previous opposite histories of 50, 65.5 and 100%, respectively. This difference in flux levels will become more meaningful as we progress.

The mechanics of magnetically writing on the tape are illustrated in Figure 5. A side cut-away view of a typical write head is shown. This view has been greatly magnified such that the pole tips can be assumed to be flat. The distance between the pole pieces is typically 250 to 1,000 microinches (.25 to 1 mil) and is termed "gap length." An indication of the scale of this drawing can be obtained from the distances plotted as a function of gap length.

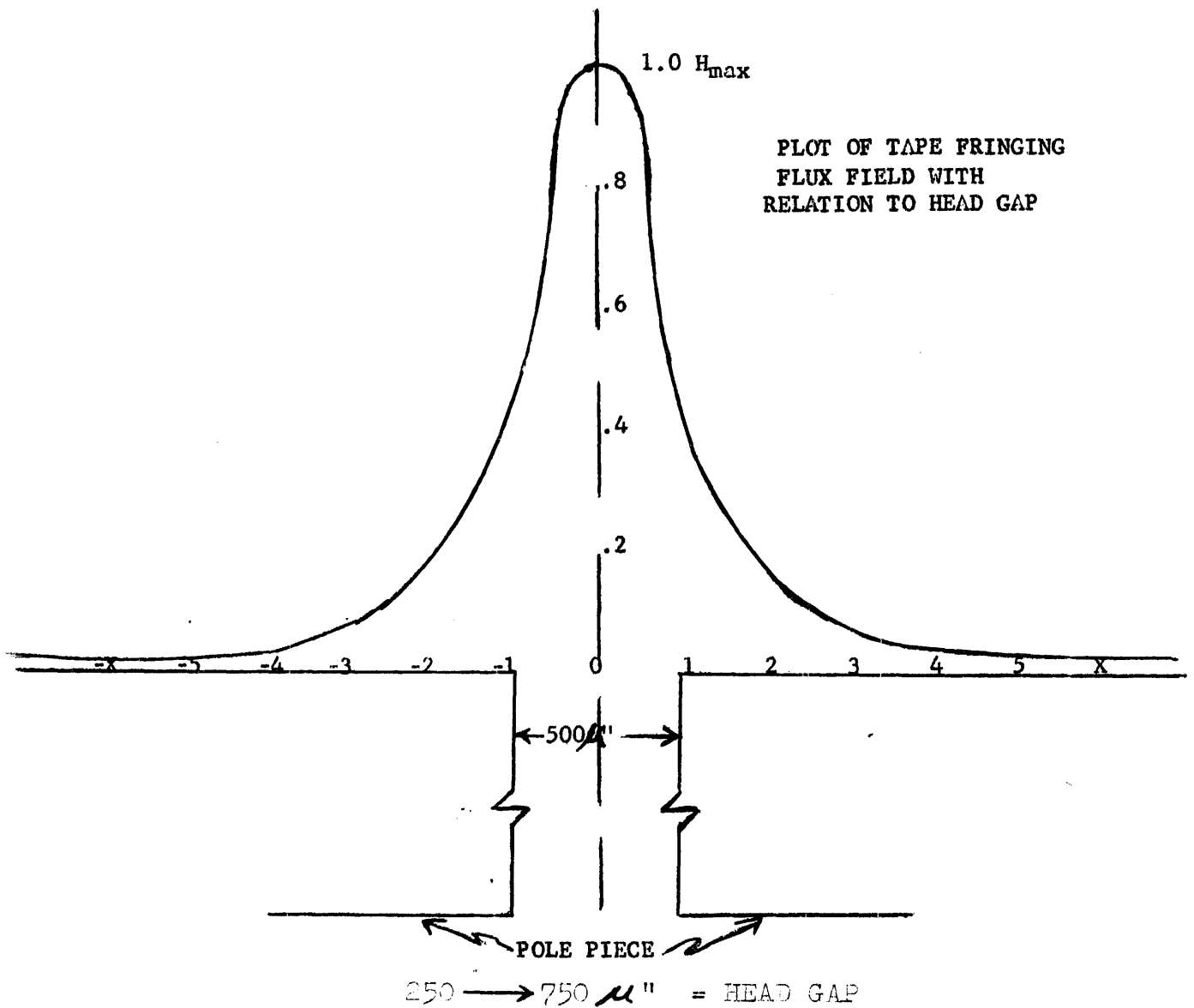

Figure 5

The average field as a function of gap length is shown to be symmetrical about the center line of the gap. If the current through the head winding is reversed, the field distribution will not change but the polarity will, as illustrated in Figure 6. The field polarity reversal results from the change in magnetic characteristics of the pole tips which is grossly represented in Figure 7.

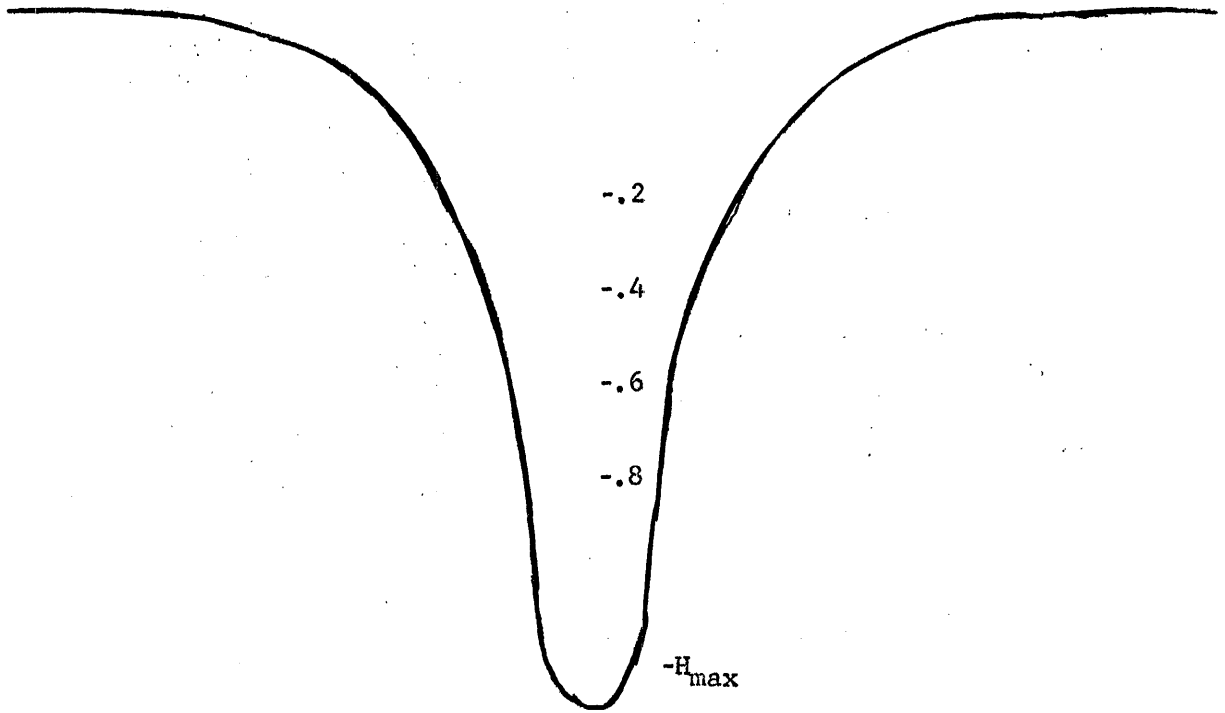

Figure 6

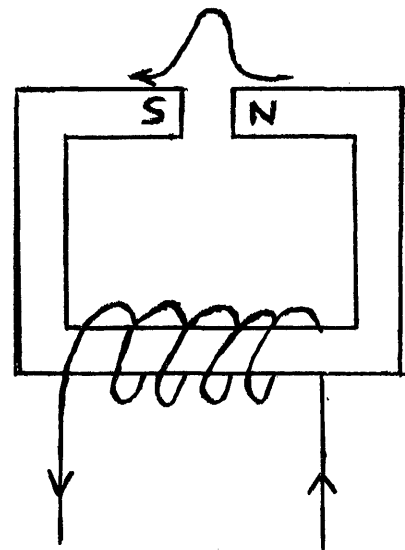
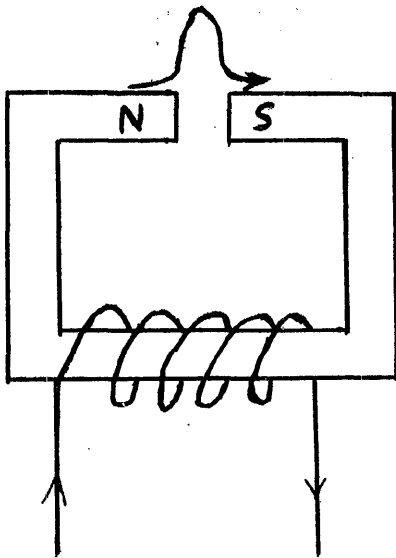

Figure 7

Here the pole tips are shown as having changed state, and the flux field direction is reversed.

When tape motion and direction is assumed in Figure 5, the point where

recording takes place can be shown. Here, tape motion from left to right will be assumed, with current flowing through the write head. The average field in the tape which results from this current is related to the number of turns and the magnitude of the current. If sufficient current is caused to flow through the write head coil, thereby causing the fringing field to saturate the tape, then

$$\frac{M}{M_{SAT}} = 1$$

M = Relative magnitude of flux field from head (1)

M_{SAT} = Magnitude of flux field required to saturate tape.

Further increases of the write current will not affect the remanent flux level of the tape. In the NRZ-M system, intelligence is written by the presence and absence of flux reversals. If we were to assume an instantaneous current (flux) reversal so the effect of tape movement can be neglected, the situation just prior to this reversal would be as illustrated in Figure 8. There the slow build up of flux to a maximum is shown.

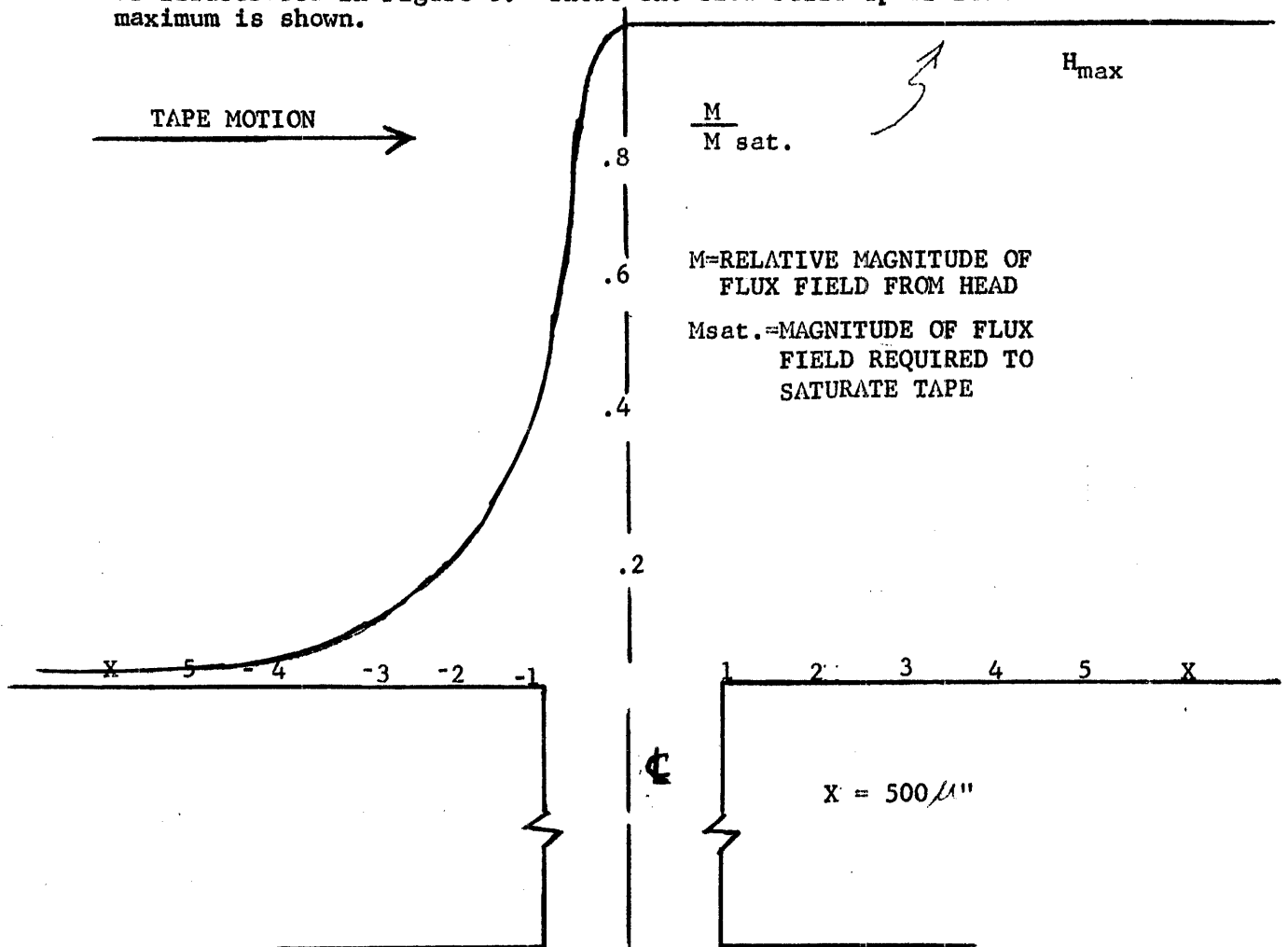

FIGURE 8

The tape to the right of the gap center line is magnetized to the saturation level, as $\frac{M}{M_{SAT}}$ was assumed to be one.

Now if we were to suddenly reverse the current through the head, a field such as shown in Figure 6 would exist. The resulting magnetization M that will result is illustrated in Figure 9.

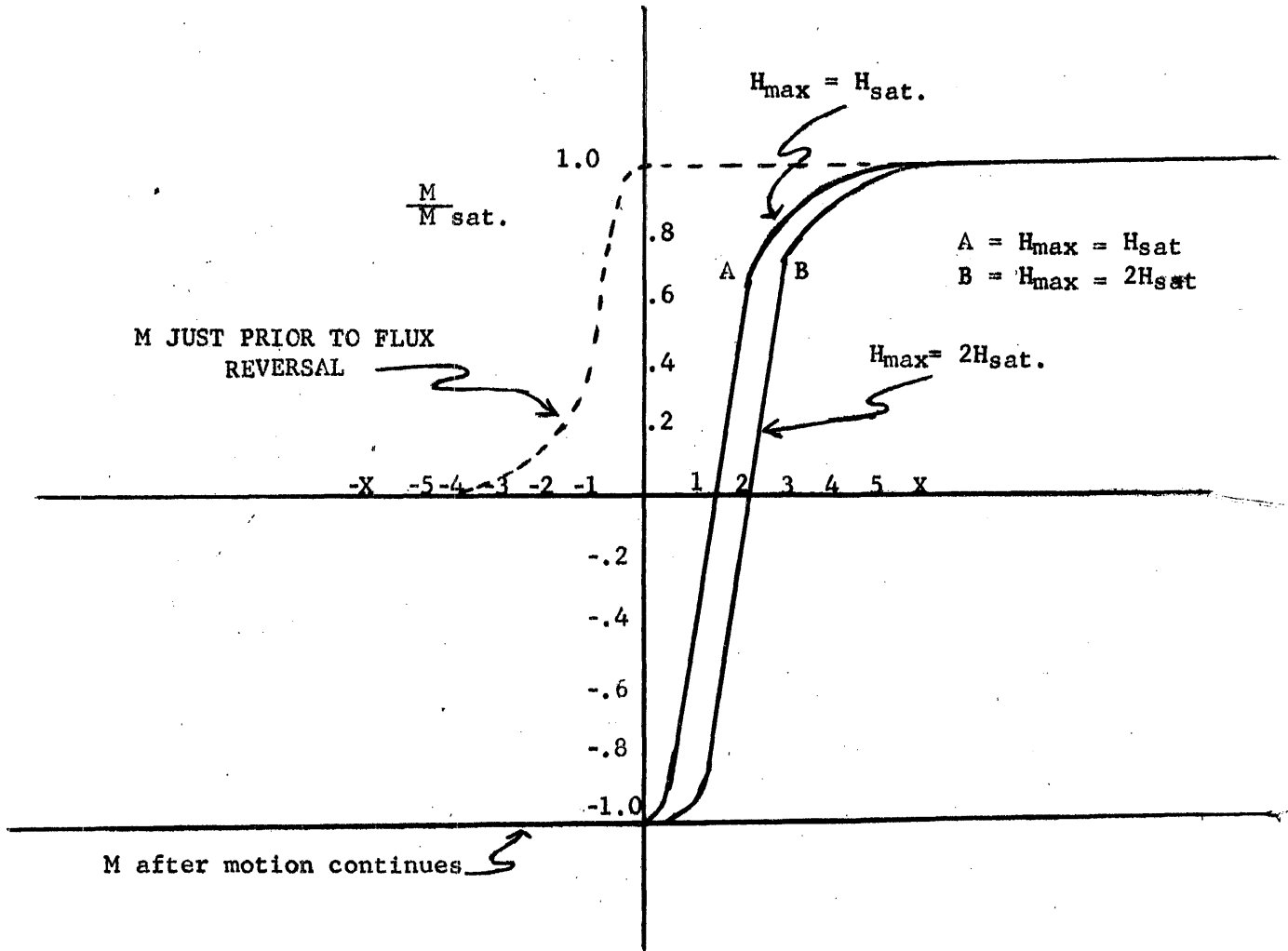

Figure 9

Here it is shown that a step function from $+M_{MAX}$ to $-M_{MAX}$ will occur to the right of the gap center line. The $M = 0$ point will shift right or left from the point indicated as function of the magnitude of the field. This is illustrated in Figure 9B where the current has been adjusted to produce a field twice that required to saturate the tape. In the case

of curve 9A, $M=0$ occurs about .32 mils to the right of the gap center line, while 9B crosses $M=0$ at about .46 mils from the gap center line. It can also be observed that the transition has a width of about .7 mils even though we assumed an instantaneous reversal of the field and no tape motion. This is one of the contributing factors which limits the maximum information storage per unit length of track where NRZ-M coding is used. The dotted line in Figure 9 represents the tape magnetization just prior to the reversal of the magnetizing field. It can also be seen that in writing (flux reversal) some erasure of previous information (flux) takes place even though the tape may have been magnetically neutral as it approached the write head.

One of the major advantages of NRZ recording is the self-erasure action inherent in this form of coding. This self-erasure is of extreme importance in computer operation, as new information can be written over old without the need of an erase system. This precludes the need for complicated mechanical head designs which are required to locate an erase head close to the write head gap. The need for close spacing becomes evident when it is recognized that the usual blank tape left between records is one inch or less. Consider the situation where the tape transport was commanded to back up to the beginning of a block. If a re-write command is then given, with an erase head location greater than say $7/8$ inch away from the write gap, it is possible to inadvertently destroy information in the previous record. The NRZ form of coding precludes the need for such a device.

The self-erasure action of NRZ recording imposes a requirement for a field greater than that necessary to establish one polarity of magnetic saturation. This field is then switched (through current reversals) to write flux reversals which transcend from $+MSAT$ to $-MSAT$. Up to this point we have assumed an instantaneous flux field reversal and no tape motion. This has resulted in a flux polarity reversal of finite length. This length is primarily a function of the head characteristics, e.g. gap length, depth of pole pieces and the magnetic geometry of the head. To the reversal length must be added the effect of the write current wave shape and tape speed. The rise and fall times of the write current must be considered. The zero flux crossing will shift location as a time function of current build-up in the write head. The rise and fall times must be equal and symmetrical or the point of zero flux crossing will shift, depending upon the direction of the flux transition. This will cause some of the transition to be smeared more than others. The rise and fall times of the write current must be fast, as compared to tape speed, or considerable tape can pass the head during the switching of the write current. Typical times of 1 to 5 microseconds are in use. The faster the tape speed, the more important this factor becomes. If the flux transition is smeared and shifted on write, the read pulse will be adversely affected. Discussion of this will be deferred until the time when the read process is discussed.

The recording of information with a flux field less than that which produces tape saturation is of some interest to us. Referring to Figure 5 where H_{MAX} will here be assumed to be equal to $.5 H_{SAT}$, and to Figure 4, it is possible to determine the state of tape magnetization. Figure 10 illustrates the condition where $.5 H_{SAT}$ has magnetized neutral tape to 80% of saturation (dotted line). An instantaneous flux reversal is presumed, which results in an $M=0$ crossing $.188$ mils from zero. It should also be noted that the magnetization has not fully switched to $-80 M_{SAT}$. This is the result of insufficient force being available. It is not until tape motion continues past the transition point that the tape will reach $-80\% M_{SAT}$. An examination of Figure 3C will reveal why. Here it is shown that a force slightly greater than $.5 H$ is required to switch from $-80\% M_{SAT}$ to $80\% M_{SAT}$. The tape motion causes a reduction in the value of the previous M so the tape flux gradually builds up to $-80 M_{SAT}$.

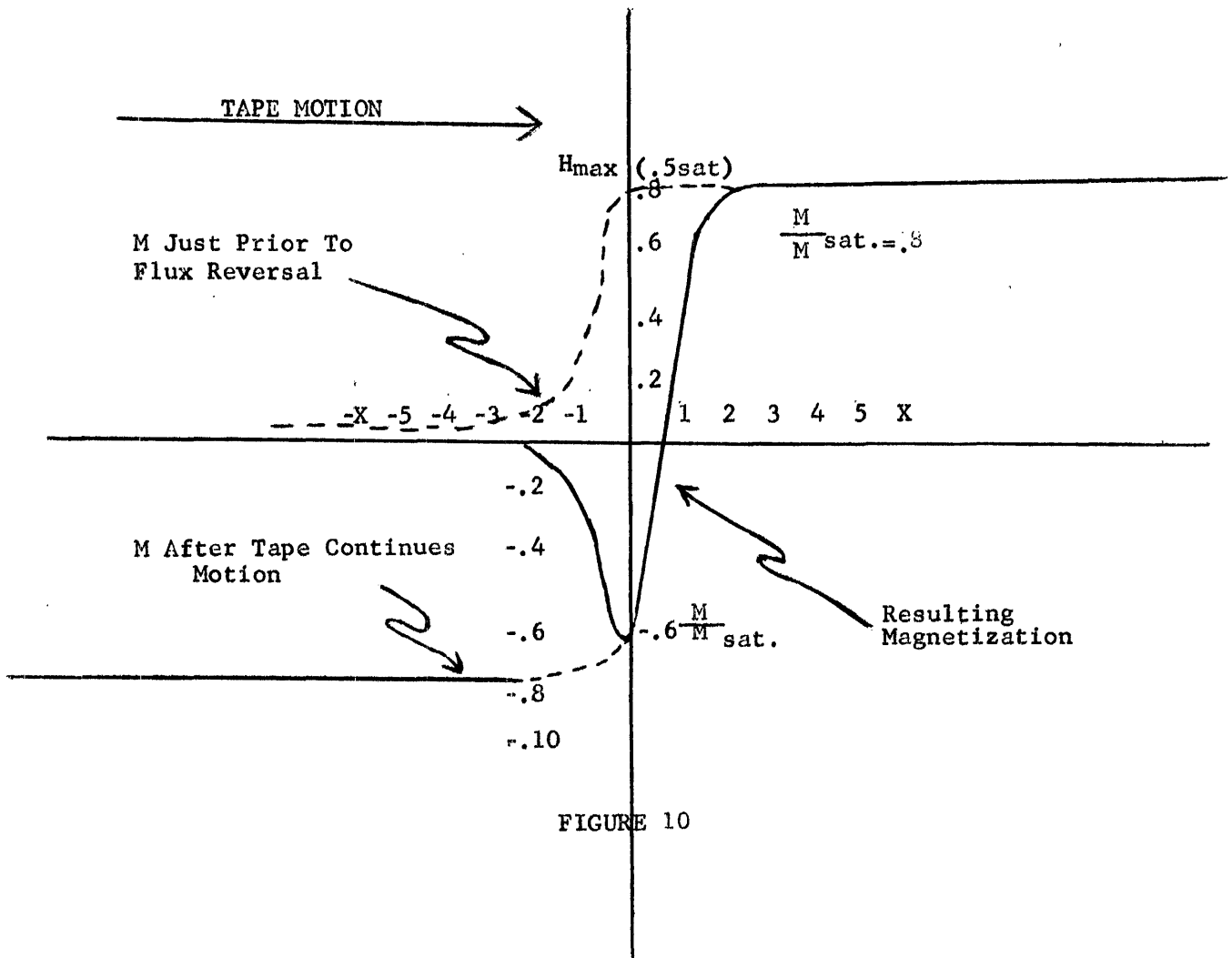

The tape is usually thought of as being under tension and in contact with the surface of the write head. This is no longer true when small particles of dust or tape oxide become trapped between layers of tape or small clumps of oxide protrude from the surface. As these particles or oxide clumps pass over the write head, they cause the tape to be momentarily lifted away from the write head. This shifts the tape with respect to the field and shifts the point at which a transition of flux takes place. This separation in effect reduces the magnitude of the flux field as seen by the tape. Such a reduction in flux field has been plotted in Figure 11. Here the flux in the tape for three different values of separations is shown. The resulting effective fields of $2X$ (no separation) $1\frac{1}{2}X$ (small separation) and 1.0 (large separation) are shown, where X equals tape saturation. The effective point of recording can be shown as shifted toward the center line of the write gap. This effect was examined earlier in this section.

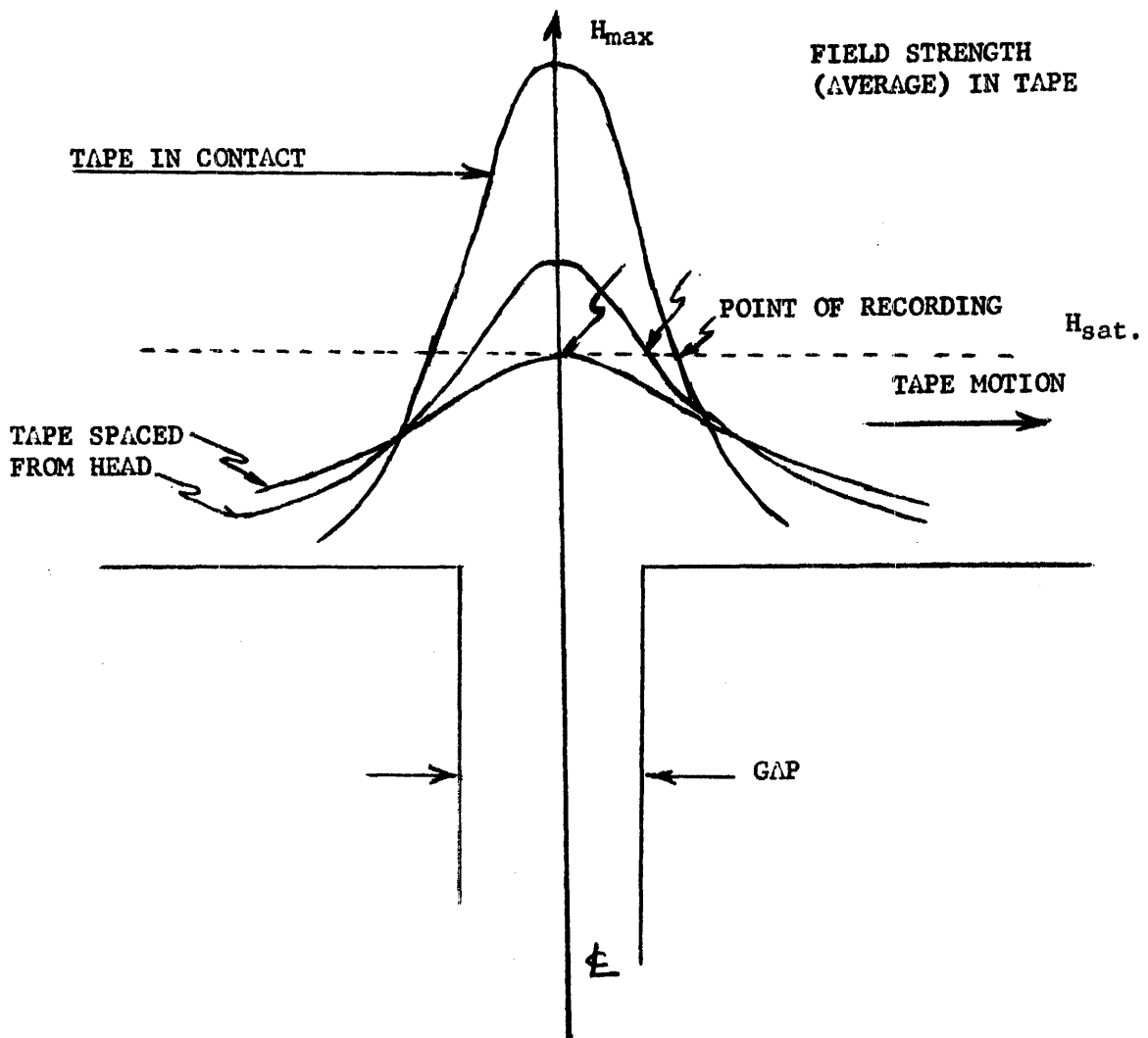

If the cause of this separation is removed (oxide particle is scrapped off as the tape passes over the head) such a displacement would not exist in this area if the tape were rewritten. This effect will be examined in greater detail when the read system is discussed. It is of some interest to note that the lifting of the tape causes the same effect as reducing the magnitude of the write current. That is, the point of recording is shifted towards the center of the gap.

The effect of the flux field amplitude in the tape has been examined. It has been shown that the point of recording shifts as a function of the magnitude of this field and of the state of tape magnetization at the recording point. It has been shown that a tape-head separation appears as a reduction in field strength insofar as the tape is concerned. It has also been shown that a field of twice saturation strength will reduce the effect of this separation to a very large degree. It may appear that these effects are of little consequence to us. In considering the single channel system of Figure 1, this would be true to a large degree. However, we will soon take up the application of these concepts as they apply to multi-channel systems. There, their importance will become evident.

READ SYSTEM

The mechanism whereby customer supplied signals were converted to magnetic flux patterns was examined in the preceding section. The purpose here will be to show how these magnetic flux patterns are reconstituted as signals which were originally presented.

The basic single channel read system is illustrated in Figure 1B. Here we see that signals from the read head are amplified, presented to a threshold discriminator, rectified and detected. An output line driver is used to supply sufficient power to send the detected signals over cables to the customer's equipment.

The types of read heads and their construction were discussed in the chapter dealing with that subject. Some of that information will be repeated here as the discussion of the read process is further developed. The read head is constructed of laminated pole pieces upon which are wound a number of turns of small wire. A voltage will be introduced into the coil by lines of force which will cut the turns of this coil as a result of tape movement. An important fact to remember is that the voltage from the coil is a function of the number of turns and the rate of change of flux per unit time. This is shown in equation one; the derivation of which is of only academic interest. ⁷

$$E_o = NK \frac{dt}{d\phi} \quad (1)$$

We have seen that in the NRZ-M code magnetic flux patterns alternate from +MSAT to -MSAT each time a binary one is written. Such a sequence is shown in Figure 12.

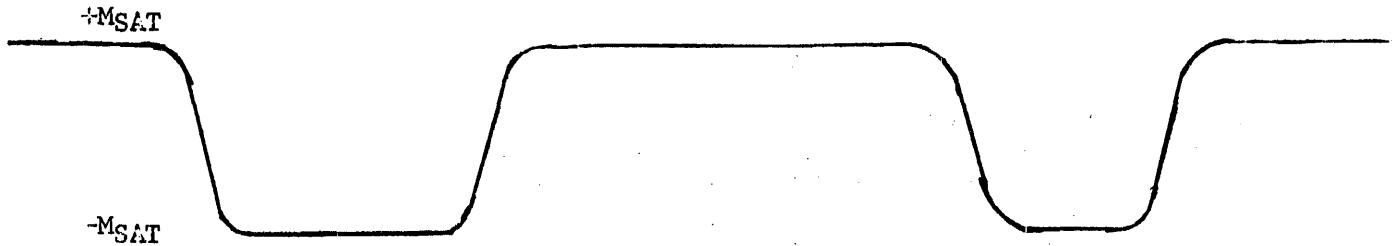

Figure 12

Here we see the finite width of the flux transition due to the combined effects of the write head, tape and tape speed. This conflicts with the highly idealized flux pattern which is often associated with NRZ-M recording. The read head output voltage amplitude, as well as the general shape of the pulse, is a function of the width of this transition. All other factors being equal, the output voltage will be greater and the pulse more narrow as the length of the recorded transition is reduced.

It will be beneficial for us to pause here and examine the read pulse. The read pulse results from a flux transition passing a read head. Figure 13 illustrates the pulse train which will appear at the output of a read head.

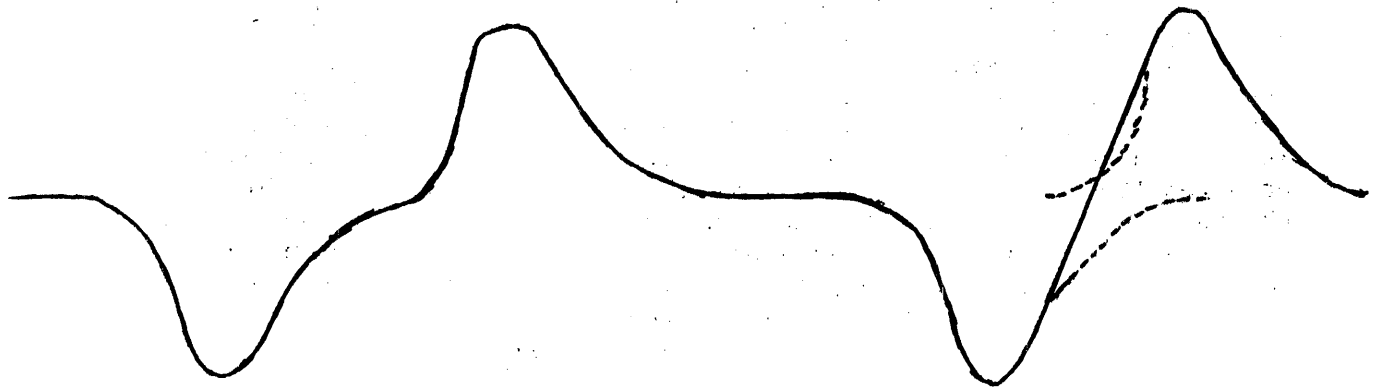

Figure 13

The pulses are those which might occur as a result of the magnetic pattern of Figure 12. The pulse can be observed as rising rapidly to a peak and then decaying at a slower rate. The polarity of the pulses is a function of the direction of flux transition, and changes with each one bit written (NRZ-M). The dissymmetry of the read pulse is generally attributed to the placement of the coil and the shape of the magnetic structure. The output pulse width (say at the 10% point) is again a function of the head and of the length of the written flux transition. When an ideal transition of zero length is passed over a read head, a pulse of a finite width will be produced. To this must be added the length of the written transition (converted to time). This then is the width of the read pulse with which the system designer must work. The maximum information density potential is then a function of the width of the read pulse plus the transition length.

The frequency components contained in the read pulse are independent of the number of transitions per unit length of track (inch). The amplitude and pulse width are functions of tape speed. The amplitude increases about 6 db each time the tape speed is doubled and the pulse width is reduced. The above statements are made with the understanding that the head is not changed. Also, the flux transition length on the tape is constant and the transitions are widely separated.

As the number of flux transitions per inch is increased, an effect known as pulse crowding takes place. This results from one flux transition modifying a preceding transition before it has left the read gap. Such a condition is shown in Figure 13 at point B. Here, the negative pulse decay to zero is modified by the approaching transition which will produce a positive pulse. When this condition occurs, the head output voltage is no longer a series of positive and negative pulses. The output voltage takes on the appearance of a rough sine wave. A reduction in output voltage will result if a further reduction is made in the distance between transitions.

If this were the only effect of close packing it would be of little concern to us. However, consider the condition illustrated in Figure 14.

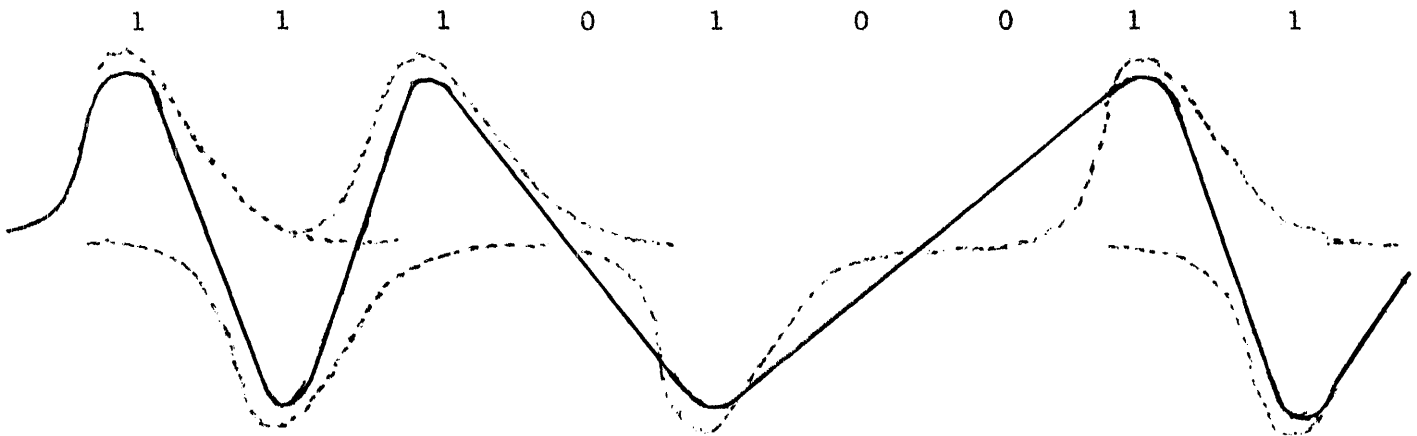

Figure 14
43

The bit distance here has been reduced to the point where serious wave form modification has taken place. The dotted lines indicate the pulse shape if only a single flux transition occurred at any one point. Note the voltage difference at points A and B. Here a binary zero was written (no flux reversal). The base line has shifted so that there exists a voltage at the time when a binary zero is to be read. The base line shift, which occurs when a series of binary zeros are spaced between binary ones, is of extreme importance to us. We will come back to this when the subject of detection methods is taken up. It should also be recognized that the frequency characteristic of the pulse train has been modified.

The read head output voltage is a function of the gap length. The longer the gap length, the greater the number of linkages (flux) that will be captured. The read head output voltage is also a function of the thickness of the oxide. The effect of oxide and gap length to pulse width and output voltage is illustrated in Figures 15 and 16.

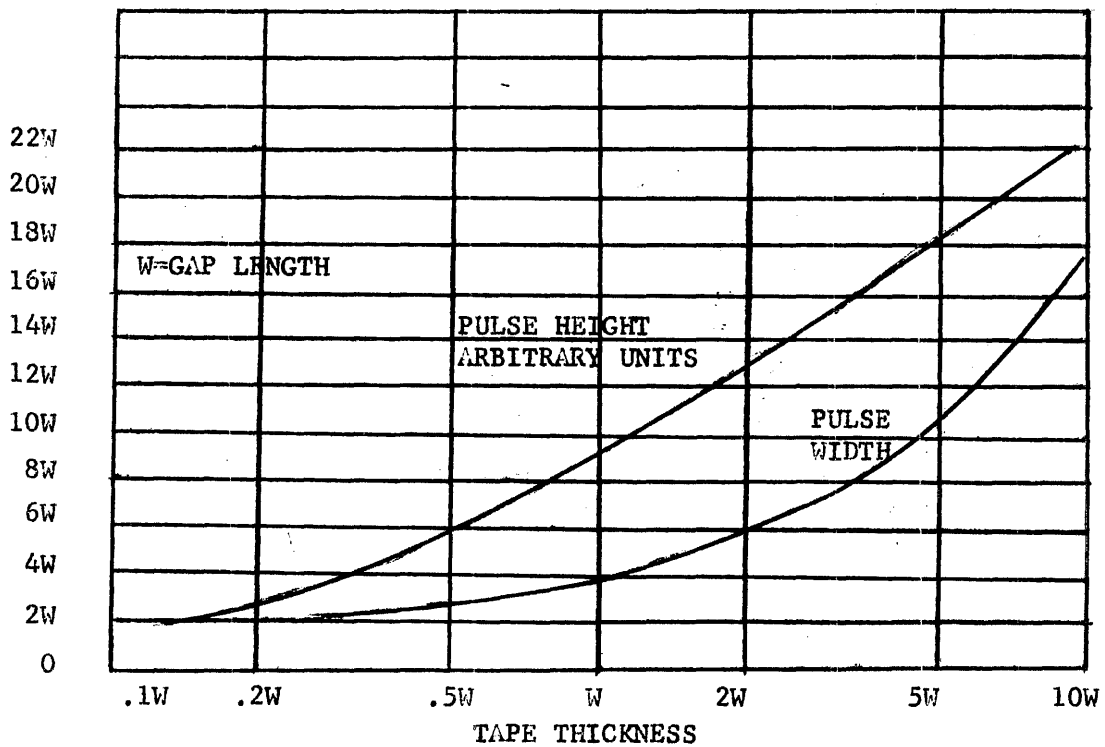

Figure 15

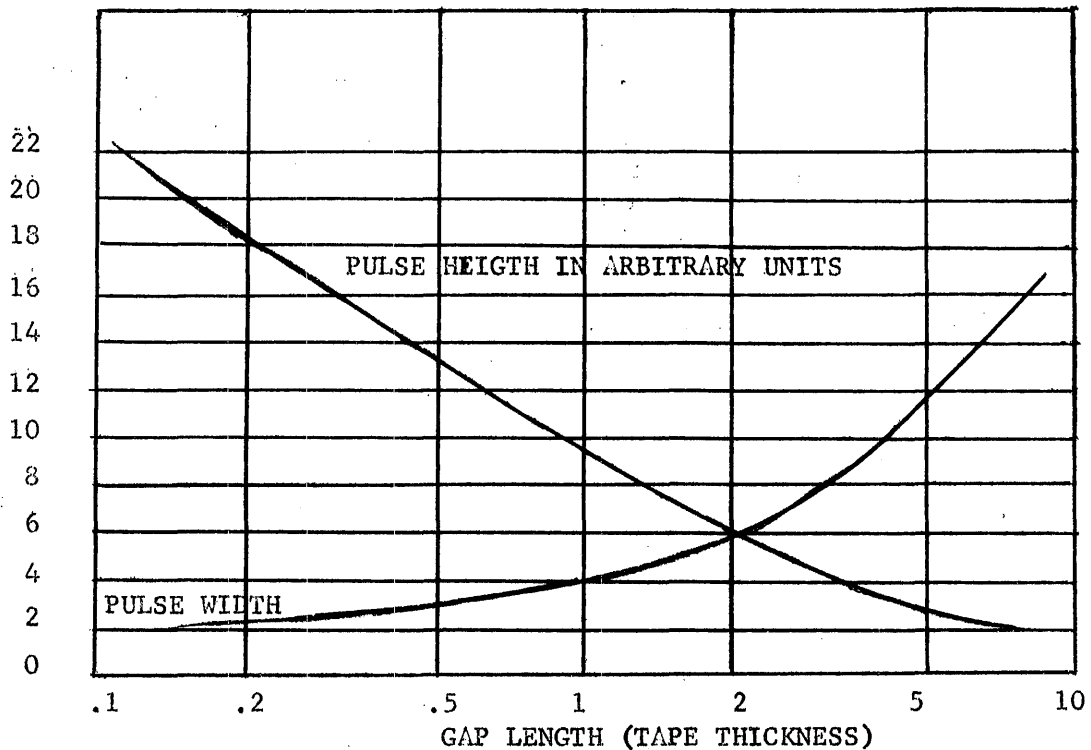

Figure 16

Careful analysis of these figures reveals that the read gap length is not critical as some have previously thought. It can be shown that the pulse width will not be significantly reduced if the gap length is reduced, say from 250 microinches to 100 microinches. This assumes that the oxide thickness is maintained at about .5 mil. However, if we reduce the oxide thickness by a comparable amount, then the pulse width will be reduced. This is paid for in a loss of read head output voltage. This trade off is one which often times cannot be made. The thin oxide will not wear as well as the thicker oxide. The life of existing tapes in some computer applications is not long enough. A reduction of tape life here would be a poor trade for higher information densities.

The read pulse width can be reduced by adjusting the resonant point of the read head. If the head is resonant just above the read head signal, a reduction in pulse width is effected. A tendency of the output signal to over-shoot and oscillate will be observed if the resonant point is made too low. This practice is usually not encouraged. It can be used if the parameters of the head and load (pre amp) are carefully controlled. Over-shoot which exceeds a few percent of nominal can cause erroneous detection. Such a condition will occur if the over-shoot exceeds the established system threshold.

The band width of the read head preamplifier must be such that the highest frequency of the read pulse is passed. The frequency response is usually about 100 to 200 KC. This bandpass is adequate for tape speeds from 50 to 150 IPS and bit densities of up to 600 BPI. A corresponding increase in frequency response must be made for higher densities (150 IPS); and the low end must be extended for lower tape speeds. The use of a differential amplifier is recommended for this application. This is due to the high common mode noise rejection which can be obtained.

The threshold discriminator is included to prevent the passage of noise pulses. There is a basic noise level at the output of the read preamplifier. This noise is a function of:

- a) The tape transport.
- b) The radiated noise environment where the memory is installed.
- c) The tape memory electronics.

The basic system noise, if allowed to pass to the detector, could result in the detection of false one bits. Therefore, a threshold level is established which will clip off the signal at some point above the base line. Any signal which does not exceed this threshold is then thought to be noise and system-wise is considered to be so. This includes valid signals which are too weak to exceed this threshold. The lower this threshold is set, the more noise susceptible the system becomes, and the greater the probability of detecting false ones in an NRZ-M system. The higher the threshold, the greater the probability of failure to detect valid signals.

We have seen that the read head output is a series of positive and negative pulses (low density). We also know that polarity of the signal is unimportant--both represent binary one. Detection of these signals can often be greatly simplified if the signals are all of the same polarity. Therefore, a rectifier is included in some systems to accomplish this function. Rectification can precede or follow threshold detection as the signal shape is not modified by the rectification process. The polarity of the rectifier output is a choice of the system designer and can vary.

The detection of the read head signal can be accomplished by detecting a voltage excursion across a threshold or by detecting the peak of the pulse. Area or other detection schemes might be used, however, they have found little use and will not be discussed here.

The level detector has been in wide use for many years. Its popularity stems from the simplicity of its design and dependable operation. At low and medium densities (200 BPI) this detector is very satisfactory. As densities are increased above this level, serious errors result in multi-channel systems. An examination of Figure 17 shows why.

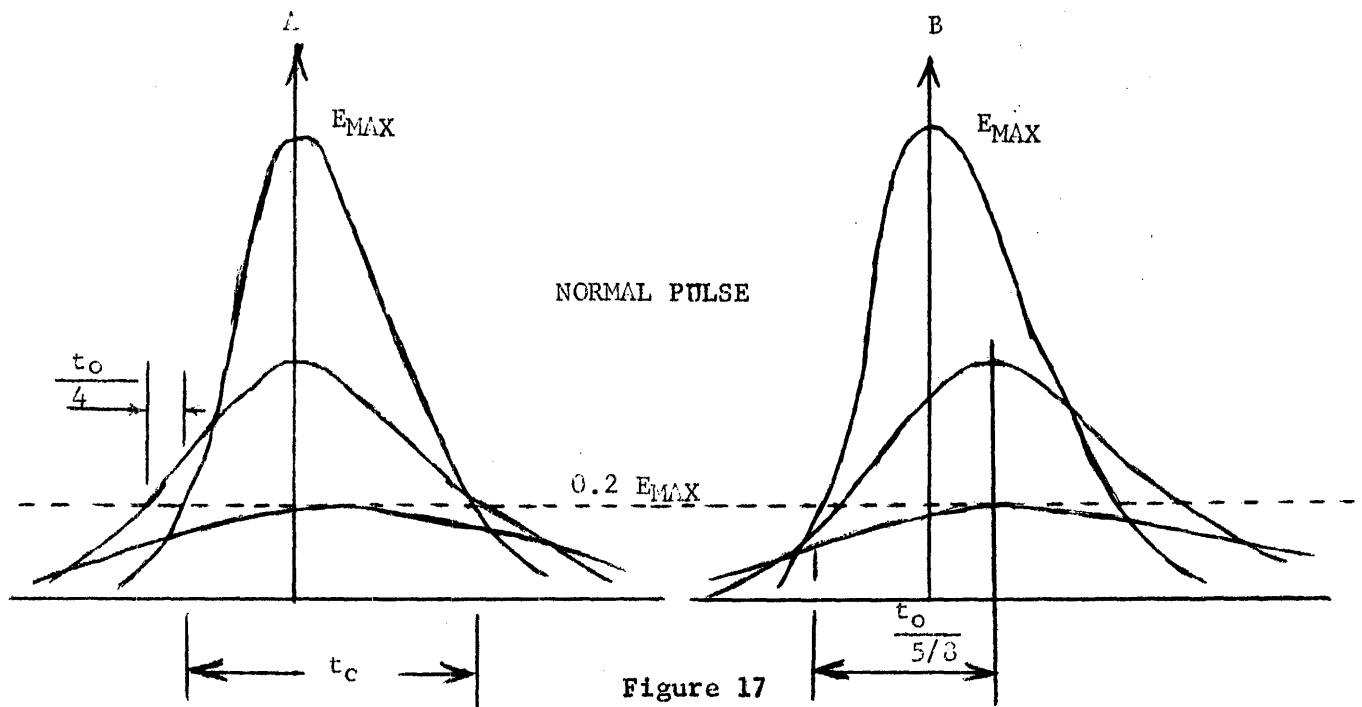

Figure 17

Here, three wave forms are superimposed for three different head-tape separations. The threshold is set for $.2 E_{MAX}$ and signals which exceed this are considered valid one bits. Figure 17A shows the read head output voltage levels of maximum (no separation), 50% (small separation), and just above 20% (large separation). The pulse width here is measured between the 20% of E_{MAX} points and is called t_0 . It can be seen that the point of detection for $.5 E_{MAX}$ is about one-fourth pulse width early and a $.2 E_{MAX}$ pulse is about one-half pulse width late. This detection error results from a read separation only. If a write separation took place when the transition was written, a shift in pulse position would occur. This was discussed earlier in the write section. This separation results in a shift of one-eighth pulse width. Figure 17B shows the condition where the pulse just exceeds the $.2 E_{MAX}$ level. Here the time error is the one-half t_0 plus the one-eighth t_0 . This is a significant detection error and limits the use of the detector.

The above discussion has neglected the possibility of noise pulses riding on the signal. A noise pulse on the leading edge of a $.2 E_{MAX}$ signal could cause an early detection or even the detection of two pulses. The possibility of noise riding on the trailing edge of a $.2 E_{MAX}$ signal could cause an error in the following character. Earlier we discussed the effect of pulse crowding. The base line shift as one effect of pulse crowding was shown in Figure 14. If the base line shift, or noise riding on the base line, exceeds the threshold, a false bit will be detected where a binary zero was written. These problems generally limit the use of the level or threshold detector to bit densities of 200 BPI or less.

Some means had to be developed which would overcome the limitations of the level detector. This was an absolute requirement in order that the information density could be increased. The most obvious approach was the development of some form of peak detection. The detection of the peak would reduce the error from $.5875 t_0$ to $.125 t_0$. The write error will still exist, but can be corrected--more on this later. The method of detecting the peak which was first used at Ampex was to differentiate the read pulse after rectification. This is illustrated in Figure 18 where A is the read pulse, and B is the differentiated pulse.

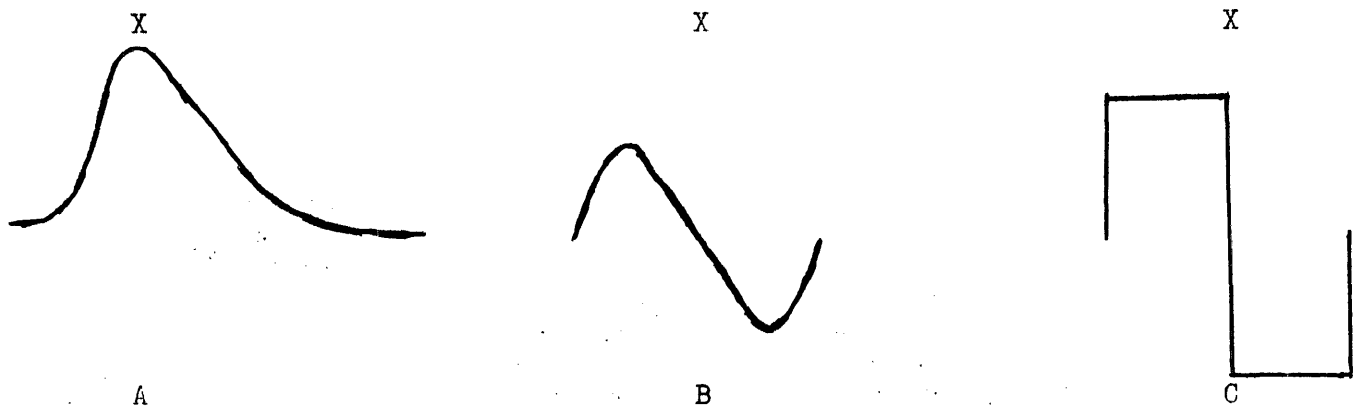

Figure 18

The wave form of C results after passing through a high gain limiting amplifier. Point X represents the peak of the read signal. The signal of C can be differentiated producing a large negative pulse. This pulse can be sent to the customer (inverted, if required) as an indication of a one bit. It is also possible to perform the detection in yet another manner. After the signal of Figure 18A is differentiated (B), one-half can be clipped off. This signal is then amplified and integrated. The fall of the integrated signal then corresponds to the

peak of the detected signal. The second method is less sensitive to noise. The output signal is the rapid fall of the integrator output, and noise pulses are filtered out in the integrator. A threshold clipper is maintained in peak detection systems, as the differentiator is sensitive to noise pulses.

The effect of the read pulse peak shift due to tape-head separations during write can be reduced. It has been found that wide-gap write heads with fields of $2 H_{SAT}$ will reduce the effect of separations to less than 2% of t_0 . This is not a serious problem at densities of 1,000 BPI or less.

TAPE TRANSPORTS

Tape transports used in digital tape memories are what their name implies. They are used to convey tape past the heads as it unwinds from the supply or file reel and to collect tape on a take up reel. Such transports are usually capable of rapidly starting and stopping the tape. In digital tape memories, the tape is assumed to be up to speed if its average speed is within 5 to 15% of the rated nominal. Tape motion is assumed to be stopped if the read head output is less than 1 to 15% of the maximum.

Up to this point, we have not considered the effect of the tape transport and of the tape as it crosses the head. The single channel system which we have discussed is seldom used. The amount of information transferred is lower than if the same information could be transferred in parallel. The number of bits to be transferred from a computer (36) usually exceeds the ability of a tape memory to write them in parallel. To transfer them in serial form would be wasteful of time. A compromise is usually made where a certain number of bits are transferred in parallel until all of the bits are transferred. For example, 6 groups of 6 bits each will transfer 36 bits in the time required to transfer 6 bits serially. This makes good use of the ability of tape to store many tracks of information across its width. A track is thought of as a location on a piece of magnetic tape and extends from one end of the tape to the other.

As tape passes over the write and read heads, some undesired movements take place. These movements can be termed transverse, lateral, and longitudinal, which define the axis over which the movement takes place. Transverse movement has been discussed in the preceding sections. Such movements are usually termed separations (head to tape).

In an ideal situation, tape moves across the heads in a smooth, straight and continuous manner. We know that this is not the case. In practice, longitudinal tape motion across the head is irregular due to power line frequency changes, eccentric rotary elements, and tape friction effects. This causes the bit transition distance to vary on write and the pulse time to fluctuate on read. The amount of such irregular movement would limit the bit packing density on a single channel. It is a serious

limiting factor in multi-channel systems.

Tape movement in the lateral axis is one of the largest sources of error in multi-channel tape memories.

Such movement is characterized by one edge of the tape leading the other in time. This results in some bits being written ahead of others along the length of the tape. This dispersion of bits will cause a time differential of detection when this information is read. This is a constantly moving situation. Correction is required if the information is to be returned to the customer in a useful form. The lateral and longitudinal movements are called dynamic skew or jitter. No attempt is made to separate the effects over short time intervals. Flutter or longitudinal tape motion variations are measured (long intervals) and such data is usually present in specifications concerning tape transports.

CHAPTER 6

COMPUTER FORMATS

GENERAL

All logical and arithmetic operations within a digital computer take place utilizing a basic unit termed a "word." A word is made up of an ordered set of bits which can represent information to be processed or instructions as part of a processing routine. The term "bit" is a commonly used abbreviation of binary digit. The bit is the smallest unit of information capacity and can represent only the quantities zero or one. Each bit position within a word has a value depending upon its positional location with respect to a reference. ¹¹ The next higher computer level is the record or block, which is a group of words referred to as a unit. The highest level of computer information is the file. A file is a series of records concerning a given situation. An analogy can be drawn between the bit, word, record and file computer terminology with that of the alphabet, word, sentence and paragraph of our language.

Several methods of loading or unloading computer information or instructions are used depending upon the computer. The method which is most widely used today is magnetic tape. The requirement of matching the capabilities of tape memories against the computer is a subject of the individual sections which follow. A general discussion of a computer will precede the discussion of a tape format. It is felt that the reader will gain a better perspective from this and will be more appreciative of the details of the individual formats.

INTERNATIONAL BUSINESS MACHINES

Information and instructions enter and leave the computer through what are termed Data Synchronizer channels. The number of these channels varies from system to system. There may be one or more Tape Unit Controllers tied to each Data Synchronizer channel. From one to eight Tape Stations are connected to each Tape Unit Controller. Information is written or read from the Tape Stations under control of the stored program or by command from the control console.

The basic word length used by most current IBM computers contains 36 bits, including a sign bit. This 36-bit word is transferred from the main memory unit (core or drum) to a Data Synchronizer channel. There the 36 bits are arranged in such a manner as to make them suitable for recording. The format used by IBM has centered around 7 tracks

on one-half inch wide magnetic tape. Evolutionary advances in the recording art resulted in the recent announcement of systems called Hypertape and Tractortape. At the time of this writing, 7-track format is the most prevalent--indeed, it has established an industry standard within the United States. Indications are that the 7-track format will be replaced by systems which have greater performance capability during the next three to five years. We will, however, be very much concerned with 7-track format until this occurs.

IBM 7-TRACK FORMAT

The 36-bit computer word is divided within the Data Synchronizer into 6 groups of 6 bits each. The Tape Unit Controller selects a Tape Station. This selection of a Tape Station is accomplished as part of a stored program or manually from the computer console. The selected Tape Station is placed in the write status and information transfer begins. A parity check is made of the data groups and a check bit is added prior to recording. The check bit is used to make the total one bits of each 6-bit group odd or even, as a function of the recording mode. Recording mode as used here refers either to binary recording or to a form of BCD recording. Binary and BCD recording are discussed in detail in subsequent sections and will not be dealt with here. The 6-bit groups, together with their individual parity check bits, are successively recorded laterally across the tape, one group at a time. Thus, the 36-bit computer word is composed of 6 tape characters. The term "character" refers only to magnetic tape and contains the 6 data bits plus the parity check bit. In the BCD mode the character contains one unit of BCD information. Each character occupies a single vertical column oriented laterally across the tape. A block of characters recorded consecutively on magnetic tape is referred to as a record. This process is repeated until all characters which are to be associated with a particular record have been transferred to magnetic tape. The number of words which constitute a record is unrestricted within the physical limitations imposed by the length of the tape itself. Between each pair of records on the magnetic tape there is associated a 3/4 inch spece of blank tape. This blank tape is referred to as the "end-of-record" gap and is provided for the stopping and starting of a tape transport between records. Records may also be grouped together in blocks, thereby forming a file. Files are separated by "end-of-file" gaps. An end-of-file gap is a 3.7 inch length of blank tape followed by a tape mark. This gap and/or mark is recognized by the stored program. The number of records in a file, like the number of words in a record, is variable and is determined by the program. Any number of records may make up a file; there may also be one or more files on a tape. The end-of-file gap of 3.7 inches is retained for compatability purposes with some of the earlier IBM 700 Series computers. The IBM 709 and other later series computers do not require the 3.7 inch end-of-file gap.

PARITY

When information is transferred from the Data Synchronizer unit through the Tape Unit Controller, a parity bit is added to each 6 data bits such that the total number of bits is either even or odd. These groups are then recorded sequentially along the length of the magnetic tape until all groups associated with a given record have been transferred. At this time, a delay is inserted and the final character, a longitudinal parity check mark, is written. There are 7 bits contained within this parity check mark; one bit associated individually with each of the 7 recorded tracks. The total number of one bits in each of the 7 recorded channels shall be even at the end of the record. If this condition has not been satisfied, a one bit is added in the longitudinal parity check mark, thereby causing this condition to be satisfied. If the total number of one bits on a given data channel within a given record is even at the time that the information transfer has been completed, a binary zero is recorded at this channel. The longitudinal parity check mark is always an even parity check, whereas the lateral parity check mark associated with each of the tape characters may be odd or even, depending upon the mode of information recording. The parity check marks are used during the read process to establish agreement with the information which has been previously recorded. Failure for agreement to be established causes an error indication. Depending upon the stored program, the tape may be back-spaced and re-read as many times as indicated by the program. At the end of this time, failure to transfer valid information as indicated by the lack of a valid parity will cause the program to be terminated and the alerting of an operator. Such a cessation of a program is termed a Programmed Interrupt. Such program interrupts are costly in terms of computer rental charges, which places a very stringent requirement upon the design of magnetic tape memory devices for absolute maximum reliability of the information recording and reproducing processes.

BINARY RECORDING

The recording of information just as stored in the main memory is termed "binary recording." When writing is taking place, check bits are added as previously indicated to make the total number of bits odd. Figure 1 illustrates the condition of the tape when the computer word 10001011101110111110110111011010 is written.

C	1	0	0	1	0	0	← Check Bits
B	1	1	1	1	1	0	
A	0	1	0	0	1	1	
8	0	1	1	1	1	1	
4	0	0	1	1	0	0	
2	1	1	1	0	1	1	
1	0	1	1	1	1	0	

Figure 1

BCD RECORDING

Auxiliary equipment such as printers, plotters, magnetic tape to punch card, punch card to magnetic tape conversion equipment requires information which has been recorded in the BCD format. The term BCD refers to a method of information coding where decimal digits are represented by a group of binary bits. The IBM BCD format is capable of recording alphabetic and special symbolic information in addition to the base ten digits, zero through 9.

100010	100100	001000	001001	000111	000011
Check bits → 0 0 1 0 1 0					
1 1 0 0 0 0					
0 0 0 0 0 0					
0 0 1 1 0 0					
0 1 0 0 1 0					
1 0 0 0 1 1					
0 0 0 1 1 1					
K M 8 9 7 3					

BCD Word Recorded on Tape

Figure 2

Figure 2 illustrates several typical BCD characters as they would be written on the magnetic tape in the IBM format. As information is transferred from the computer memory to the magnetic tape, certain bits are altered as is shown in the following table:

Character	In Storage	On Tape	Character	In Storage	On Tape
0	00 0000	00 1010	-	10 0000	10 0000
1	00 0001	00 0001	J	10 0001	10 0001
2	00 0010	00 0010	K	10 0010	10 0010
3	00 0011	00 0011	L	10 0011	10 0011
4	00 0100	00 0100	M	10 0100	10 0100
5	00 0101	00 0101	N	10 0101	10 0101
6	00 0110	00 0110	O	10 0110	10 0110
7	00 0111	00 0111	P	10 0111	10 0111
8	00 1000	00 1000	Q	10 1000	10 1000
9	00 1001	00 1001	R	10 1001	10 1001
#	00 1011	00 1011	Ō	10 1010	10 1010
@	00 1100	00 1100	\$	10 1011	10 1011
&	01 0000	11 0000	*	10 1100	10 1100
A	01 0001	11 0001	Blank	11 0000	01 0000
B	01 0010	11 0010	/	11 0001	01 0001
C	01 0011	11 0011	S	11 0010	01 0010
D	01 0100	11 0100	T	11 0011	01 0011
E	01 0101	11 0101	U	11 0100	01 0100
F	01 0110	11 0110	V	11 0101	01 0101
G	01 0111	11 0111	W	11 0110	01 0110
H	01 1000	11 1000	X	11 0111	01 0111
I	01 1001	11 1001	Y	11 1000	01 1000
Ō	01 1010	11 1010	Z	11 1001	01 1001
.	01 1011	11 1011	‡	11 1010	01 1010
□	01 1100	11 1100	,	11 1011	01 1011
			%	11 1100	01 1100

Table I

The digits one through nine are represented by the six binary numbers 000001; that is, by their exact values as binary integers, zero is represented by 001010 or binary 10. The first two digits of the BCD information thus transferred is referred to as the zone, and is recorded on tracks labelled "B" and "A" in the IBM format. During the transfer of numerical information, the zone bits are not modified. However, during the transfer of alphabetic and symbolic characters the zone bits are modified; thus, they are not the same on tape as they exist in the main computer memory. Figure 3 illustrates the conversion which has taken place.

Class	In Core Storage	On Tape
	BA	BA
Numerical	00	00
A to I	01	11
J to R	10	10
S to Z	11	01

Figure 3

The alteration of the zone bits permits the recording of the alphabetic numerical information in ascending order of magnitude within the core storage unit of the computer. During the read process, the alteration is reversed so that the tape information is transformed suitable for storage within the main memory. During the writing process, the Tape Control Unit automatically performs modifications as described, but does not check the 6 bits being transmitted for validity. Thus, if pure binary numbers are written in the BCD mode, it is possible that both a pure zero and the number ten (001010) will be recorded on the tape as a BCD character zero (001010). Also, the integer fifteen (001111) is identical to the BCD tape character mark signifying an end-of-file condition. In general, therefore, random binary information should not be recorded in the BCD mode. In addition to the alpha numeric and symbolic information discussed previously, there exists a BCD character "Blank" which is used to suppress printing or punching in any position in the desired auxiliary operations.

When a tape is prepared by auxiliary equipment or by a 702, 705 or 650 data processing system, it is possible that some records do not contain integral multiples of 6 BCD characters. When such records are read by later 700 Series computers, the last word of that record will be incomplete in that it will not contain six 6-bit characters. The characters comprising incomplete words are placed in the high order positions. The other remaining positions are filled with zeros. Information which makes up an incomplete word is subjected to the same check procedures as that comprising a complete word. When the incomplete word is transmitted to core storage, the contents of the word register in the Data Control Synchronizers are reduced by one, and the contents of the address register are increased by one, just as though a full word had been read.

TAPE FORMAT DETAILS 12-13-14-15-16

The term "IBM compatibility" refers to tape inter-changeability and not to equipment substitution. To define areas of compatibility, it is necessary to determine the requirements for IBM systems. The following points have been considered in an effort to achieve, as nearly as possible, a complete description of all requirements leading to complete tape file compatibility:

1. Information density for all types of IBM tape handlers.
2. Tape format used
3. Type of magnetic recording used (coding).
4. End-of-tape and end-of-file mark.
5. Lateral parity requirements.
6. Longitudinal parity requirements.
7. Output levels (tape).

INFORMATION DENSITY AND TAPE FORMAT FOR ALL TYPES OF IBM TAPE HANDLERS

Table II compiles several important parameters which relate to the seven different IBM tape handler systems. The older systems operate at bit densities on each track of 200 or 556 bits per inch (BPI). Newer systems are capable of 800 BPI on each track.

TAPE FORMAT USED

Other characteristics of a tape are also given in Table II. Figure 4 is a composite illustration of the low and high density tape formats used in the IBM systems. The high density tapes also provide wider tracks than their predecessors, up to 0.048 inch in width. The IBM 727 utilized a DC erase head which has been omitted in the newer IBM 729 machines. The wider track width has been adopted to be sure of thorough erasure of previously recorded information.

TYPE OF RECORDING

In all cases NRZ-M recording is used, with each flux change representing a binary one on the tape. A binary zero is the absence of a flux transition on the tape. A 7-track configuration includes a 6-bit binary or alpha numeric character, with a seventh track used for the parity bit. In the IBM system, a clocking arrangement is used to insure that all bits of a particular character are read from the tape handler simultaneously. This clock is derived from the characters as read from the tape by means of a 7 input OR circuit. The clock pulse generated from the OR circuit responds to the first of seven arriving data bits to be read. It is important that the polarity of the write

head agrees with the polarity of the erase head prior to the writing of the first bit. This situation is assured by special checkout procedures. Following the initial bit, the residual flux left on the tape is reversed and continues to be reversed for each succeeding bit within a record. Following the last character, a blank interval is left corresponding to approximately three character spaces (see Figure 1). Following this, an additional bit is written as a parity symbol in order that the total sum of all the bits within a particular track be even. In this way the polarity of the residual flux following the longitudinal parity symbol is returned to the same condition as the original flux level. The 729 tape handler head is phased to be compatible with the 727 DC erase head. The flux polarity remains unchanged in all inter-record and end-of-file gaps. The inter-record gaps serve a useful purpose in tape systems by allowing sufficient distance for the tape to stop and accelerate again to normal speeds between records.

HEADS

Early heads supplied by Ampex did not fully meet the requirement of IBM 729 tape compatibility. That is, the track width of the write head was .032 inch and no means of tape erasure was provided. This precluded the writing of new information over old due to incomplete erasure. This narrow band along each edge of the track which is not completely erased by the NRZ write process results from the differences in skew between machines, even the same machine on different passes of the tape. This incomplete erasure results in lower output voltage and a decrease in signal-to-noise ratio on the read back of the recorded information.

All new heads delivered by Ampex beginning early in 1961 are fully IBM compatible. The track width and track spacing are identical. The same edge of the tape is used for a reference. The write gap to read gap spacing is identical to IBM on head assemblies used on TM-4 tape transports and is .050 inch closer on TM-2 tape transports. This will allow stop-start and read after write operation within the 3/4 inch IBM inter-record gap.

END OF TAPE AND FILE MARK

Beginning of tape (LOAD POINT). Major consideration must be given to the tape load (beginning of file) mark. This consists of a 3/16 inch wide strip of reflective material about one inch in length which is cemented to the Mylar side of the tape. This strip covers only one-half the width of the tape and is on the side furthest from the precision plate. The end-of-reel mark is similar to the load mark except that it is located on the opposite edge of the tape (see Figure 5). When a tape is positioned at its load point, and a start write instruction is executed, a beginning-of-tape gap (identical in length to an end-of-file gap) is always recorded before the first record. This gap is never interpreted as an end of file during reading from the load point.

TABLE II

IBM TAPE DRIVES

	727	729I	729II	729III	729IV	729V	729VI
Speed Inches Per Second	75±1%	75±1%	75±1%	112.5±1%	112.5±1%	75±1%	112.5±1%
Density Bits Per Inch	200±2%	200±2%	200±2% 556±2%	556±2%	200±2% 556±2%	200± 556± } 2% 800±	200± 556± } 2% 800±
Character Transfer Rate KB/S	15	15	15/41.667	62.5	11.5/62.5	15/ 41.66/60	22.5/ 61.5/90
Track Width-Write (Inch)	.032	.046	.048	.048	.048	.048	.048
Track Width-Read (Inch)	.032	.032	.030	.030	.030	.030	.030
Track Spacing (Inch)	.070	.070	.070	.070	.070	.070	.070
Write Gap to Read Gap Spacing (Inch)	Single Gap Head	0.300±.002	0.300±.002	0.300±.002	0.300±.002	0.300±.002	0.300±.002
Write Delay * (M Seconds)	Write Delay ±1% Load Point Delay 1%		7.5 48.0		5.0 32.0	7.5 48.0	5.0 32.0
Read Delay (M Seconds)	Read Delay ±2% Load Point Delay ±1%		4.5 24.0		3.0 16.0	4.5 24.0	3.0 16.0
Character Delay (μ Seconds)	200 BPI 556 BPI 800 BPI	33.6	33.6	29.2 10.5	21.0 7.5	29.2 10.5 7.9	21.0 7.5 5.4
Check Character (μ Seconds)	200 BPI 556 BPI 800 BPI ±11%			271.0 97.5 37.0		180.7 65.0 37.0	180.7 65.0 25.0

* When at Load Point total delay is the Write Delay plus Load Point

DT-12

58

Training Department

**SKREW PATTERN
PER CHARACTER**

LONGITUDINAL CHECK CHARACTER GAP

200 BPI = .0207" +.0126, -.0081"
 556 BPI = .0075" +.0046, -.0029"
 800 BPI = .0054" +.0033, -.0021"

200 BPI = .005"
 556 BPI = .0018"
 800 BPI = .0012"

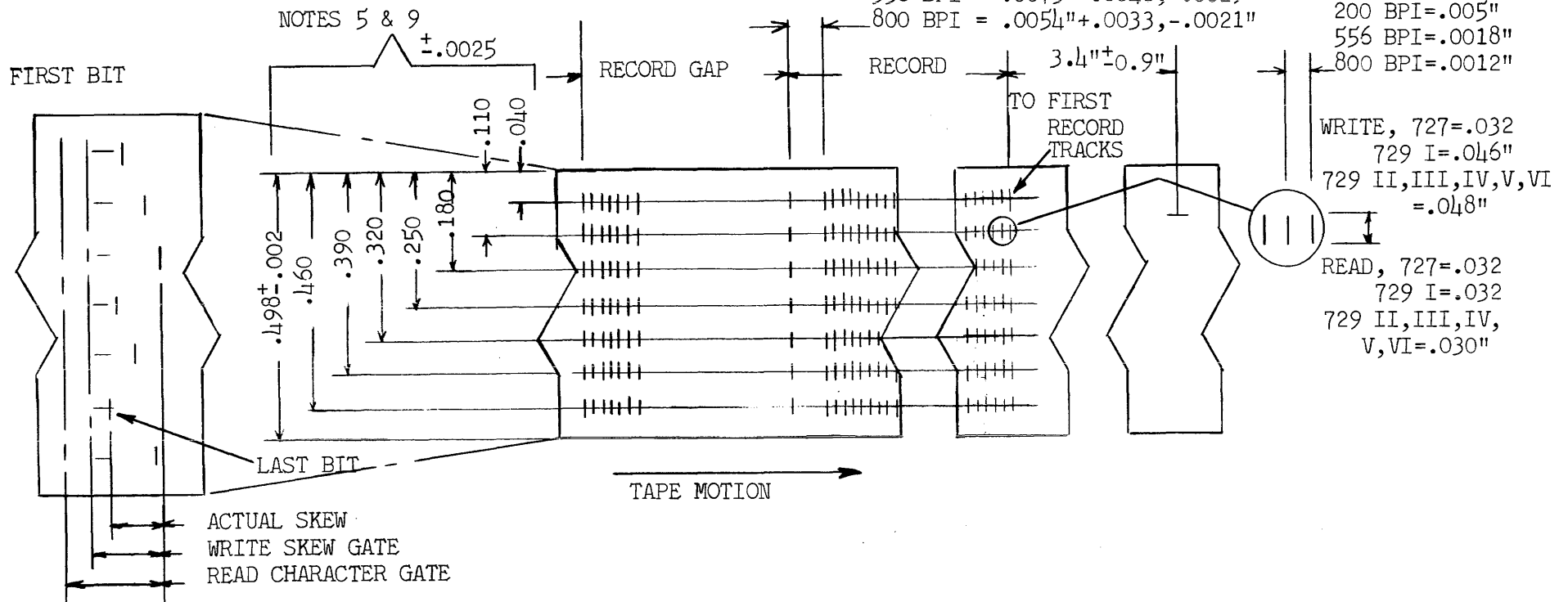

65

NOTES:

- 1) Tape is shown with oxide side up, Read/Write head on same side as oxide.
- 2) Tape shown representing 1 bits in all tracks, NRZ-M recording; 1 bit produced by reversal of flux polarity, tape fully saturated in each direction.
- 3) Variation permitted in the location of the Check Character assuming nominal values for tape speed and all oscillator timings in the Tape Control. No longitudinal check bit is written if longitudinal count in the track is even.
- 4) Mylar Tape: 3/4", +5/32", -1/16". Acetate Tape: 3/4", +5/32", -1/8". Zero backward creep. Forward creep less than 0.2" per cycle.
- 5) Dimensions of tape measured at 50% relative humidity and 70°F. Tape thickness (Mylar or IBM HD) is .0022", +.0003", -.0004"
- 6) To insure complete interchangeability, skew of each tape unit is adjusted to 0.25 usec or less at the read bus of the tape unit when reading-while-writing continuous 1 bits. Maximum skew for any reel of tape, read by any tape unit connected to any tape control, must be equal to or less than the read character gate for the bit density and tape speed at which the tape was written.
- 7) Time Between Characters: Writing--shall not be less than fall of the skew gate timing plus 1 usec, including variations due to tape speed, skew and bit configuration. Reading--shall not be less than read character gate timing plus 1 usec, including variations due to tape speed, skew, and bit configurations.

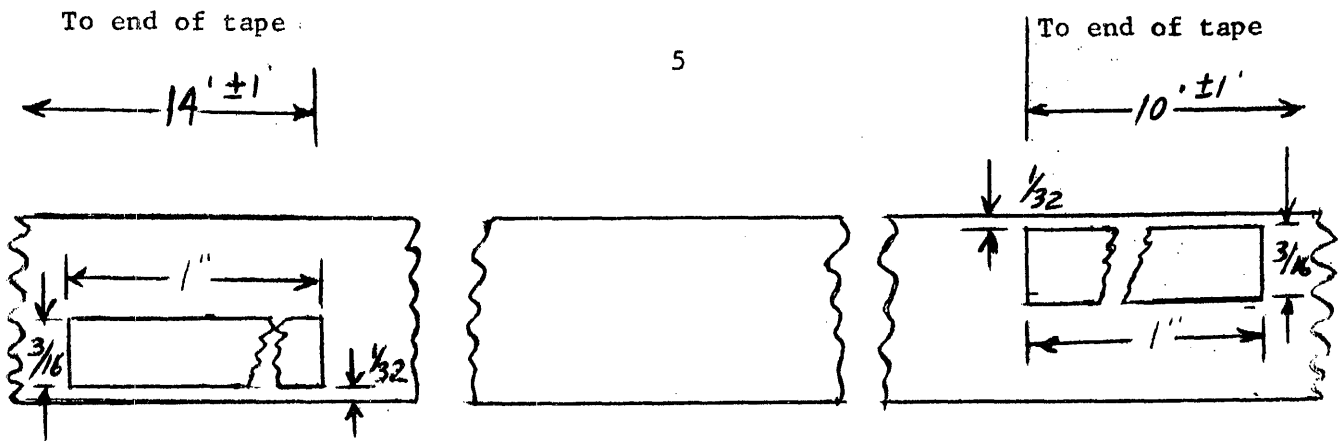

Figure 5

During reading, the tape will be spaced forward until the first bit of information is sensed, regardless of the length of the beginning-of-tape gap. The load point, with respect to the write head, had previously been positioned with the reflected spot under the photo sensor. Approach was made in the rewind direction and the tape was stopped with the illuminated spot approximately $\frac{1}{2}$ inch from the inside end of the reflective tab. This is 10 to 15 feet from the physical beginning of the tape (see Figure 5).

END OF TAPE. When the aluminum strip marking the end of the tape is reached during the writing, the photo sensor causes an end-of-tape indication to be sent to the processor. No interruption in the writing process occurs so that the writing operation may be completed, even though the end-of-tape mark has been passed over. However, if the computer were to continue to ignore the status of the signal and if writing continued, the tape would eventually be pulled from its supply reel. The end-of-reel reflective marker location is not critical. The reflective spot is located about 18 feet from the end of the reel of tape in order to give sufficient length after end-of-tape sensing to write approximately 2 feet of tape--the longest record anticipated. The computer will complete the writing operation and write an end-of-file mark.

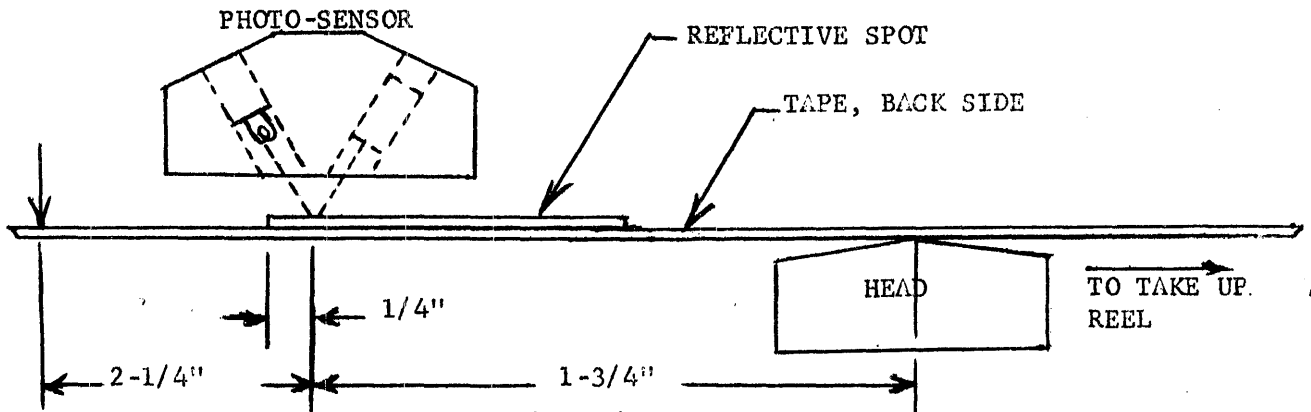

Figure 6
60

At the present time it appears impractical to use exactly the same type of photo electric sensor that is used on the IBM machines. This conclusion results from the limited space available on the TM-2 and TM-4 for locating such a sensor. The proper IBM format on the tape can be achieved by choosing a suitable write delay after the tape starts to move during the write operation. This delay is then adjusted so as to produce a comparable distance as is achieved on the IBM series of tape stations. These delays are not provided with our equipment. Rather, it is necessary that this delay be provided as a feature of the format control device by the system designer. This requirement does not differ from the method now used by IBM in connection with their tape handlers. On playback, a similar but shorter read delay is provided to be sure the tape is up to speed for transferring information from the tape.

END-OF-FILE MARK. An end-of-file mark is written following the last longitudinal check character in a file. An end-of-file mark is approximately 3.7 inches of blank tape followed by a tape mark (001111) and its longitudinal check character. This check character is identical to the tape mark itself. The tape mark and its associated check character or the end-of-file gap can signal end of file. The gap is retained to provide compatibility with the IBM 704 computer. The tape mark therefore signals an end of file in either a binary or BCD mode. In addition, it may also be used to sense the beginning of a file after a back-space file instruction. Since the information is magnetically written on the tape as a blank space or as a definite mark, sensing of this can only be achieved by manipulation of the output signals from the read/write electronics. Detection of such a signal and its use are the responsibility of the system designer.

INTER-RECORD GAPS

To produce inter-record gaps, the IBM 727 system operates with a 10 millisecond write delay and a 4 millisecond read delay. Other IBM tape transport models utilize times which may be different from these, but the effect will still be the same. The transport start and stop times are 5 $\frac{1}{2}$ milliseconds each. The 3/4 inch inter-record gap arises from these delays as follows:

Stop:	$\frac{75}{2} \times .005$	=	.1875
Start:	$\frac{75}{2} \times .005$	=	.1875
(Additional cue to write delays)			
	$75 \times .005$	=	<u>.375</u>
Total:	0.750 inches		

The permissible tolerance of the inter-record gap is determined by the differences in the read and write delays. This turns out to be on the low side. Ampex equipment can provide stop and start characteristics to meet this requirement, but externally provided command delays must be adjusted to the tape speed used. For complete compatibility with the IBM 729 system, it is necessary to provide separate read and write heads to permit verification of the data while writing. The IBM read and write heads are separated by a distance of 0.3 inches. Following completion of a block of data, the information is normally read and checked for longitudinal and vertical parity before stop command is given. Following the stop, the tape must be accelerated to operating speed before the next block is written. All this must be done within the normal 3/4 inch inter-record gap. Obviously, the distance between heads imposes more severe starting and stopping restrictions on the tape transport. To achieve operation with the 3/4 inch standard inter-record gap, the starting and stopping distance must not exceed 3/4 inch less the distance between the read and write heads. For instance, using standard Ampex IBM compatible head assemblies, the sum of the starting and stopping distances should not exceed:

1. TM-2 - .750 inch minus .250 inch = .50 inch
2. TM-4 - .750 inch minus .30 inch = .450 inch

ELECTRONICS

As indicated previously, NRZ-M electronics are required for writing and reading IBM tapes. However, the writing operation requires clearing of all write flip-flops (register) to a common level prior to writing the first bit. To do this, the system designer has two choices. One would be to AC reset the NRZ-M write register to zero before enabling the write permit line. This would insure that the current through the write heads would flow in the same direction and be phased such that the magnetic flux would be the same polarity as the inter-record gap. The second and more desirable method would be to hold the NRZ-M write register to zero by a DC reset, the DC reset being removed with the application of a write permit signal. The longitudinal parity check mark could then be written by the application of an AC write reset signal common to all flip-flops in the NRZ-M write register.

PARITY

Two kinds of parity checking are provided in the IBM system. Lateral parity is the most useful and most universally used in computer systems. Longitudinal parity is also used to make sure that drop-out cancellation errors will not go undetected. The lateral parity check involves the use of channel C on the tape (see Figure 1). In the binary mode, a logical check of the 6-bit number on channels 1, 2, 4, 8, A and B is made to see if the sum of all the bits is odd or even (this is a numerical sum and, of course, cannot exceed 6). If the sum is even, an additional

bit is added in channel C (parity channel). Therefore, the sum of all bits in each character must be odd. If the sum is not odd, a parity error will be indicated to the computer upon read back of the written information. Appropriate corrective action is under control of the stored program in the computer. For alpha numeric or BCD code an even parity check is used. In this case, the 6 data bits are inspected for an odd sum. If the sum is odd, a parity bit is added to the C channel. In this case, the parity check is for an even sum.

These two systems of parity checking are different for the convenience of the computer. Information written in binary notation and in alpha numeric codes is not compatible, and the computer must know which one it is working with. If the computer is set up for a binary code, it cannot accept the other; hence, an alpha numeric tape placed on the computer programmed for binary information will immediately show successive parity errors. Obviously, the reverse condition is also true.

The longitudinal parity check is actually a by-product of the action of resetting flip-flops prior to recording a record and immediately following a record. The input register is first cleared, being that all 7 bits are returned to a common initial state. Following completion of a record, an interval corresponding to three character spaces exists, after which all input registers are again cleared. Those which are left in a condition opposite to the initial state are flipped to the starting condition, resulting in a recorded bit on the tape. On playback, a logical check of the longitudinal parity is made to make sure that the sum of all bits in all tracks is even. The purpose of the combined use of the longitudinal and lateral parity is the detection of dual errors. When a single channel fails, an error will be indicated by the lateral parity checker. This failure can be caused by a signal dropout (read head output) below an established threshold, or by a drop-in (noise pulse). When two errors occur in a single character, a valid parity indication will be given by the parity checker. Such self-cancelling errors can occur from these causes:

1. Two dropouts of one bits on different channels.
2. Two drop-ins of one bits on different channels. It is necessary that these channels have zeros or the drop-in will not be detected as invalid.
3. A drop-in on a channel containing a zero and a dropout on a channel containing a one.

These errors will not be detected by a check of lateral parity. A longitudinal parity check will detect errors of this type as the channels will not end in the same phase as they started (an even number of one bits). Such errors are detected by causing a F/F to change state each time a one bit is read from the tape. If the F/F is not returned to the zero or starting state after the longitudinal parity mark, an error will be indicated.

The lateral/longitudinal system of parity checking is not infallible. It is still possible for self-cancelling errors to occur and go undetected. The probability is quite remote. This percentage of error is usually not considered--but you should be aware that they could occur under remote circumstances.

OUTPUT LEVELS

In order for detection systems to work properly, the output voltage levels from the read head must be the same for all kinds of tape used. This means that tapes recorded on an Ampex machine or an IBM machine must exhibit approximately the same output voltage levels for a given tape speed and packing density. This being the case, a threshold level can be established above which the detection of the information can be considered a valid one. Any level from the reproduce head which does not exceed this threshold is then considered to be a binary zero. In selecting a tape for the recording of IBM information, care must be taken to insure that the residual magnetism following saturation NRZ-M recording will produce a read output level compatible with that of a tape which is furnished by IBM. (See Chapter 2 which discusses tape in greater detail.)

IBM TAPE STATION DESCRIPTION: 15

A typical IBM magnetic tape station is shown in Figure 7. The tape passes through two vacuum columns located on both sides of the READ-WRITE head and is then taken up by a supply reel. The READ-WRITE head performs the operations of recording or WRITING information on the tape and reproducing or READING information from the tape as the tape is moved across the head. The vacuum columns permit constant speed of the tape without waiting for the reels to accelerate or decelerate when starting or stopping.

SCHEMATIC, TAPE UNIT

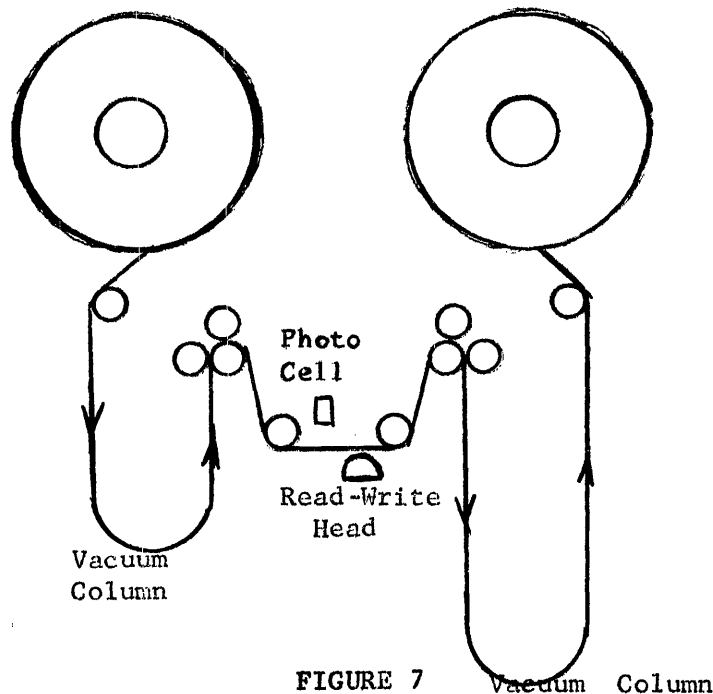

FIGURE 7 Vacuum Column

Tape motion is related to records on the tape in the following way. A tape may never stop in the middle of a record. Thus a partial record may be read into core storage under program control but the physical motion of the tape continues until an end-of-record or end-of-file is sensed. During writing, an end-of-record gap MAY be written while the tape is moving at full speed. However, before the tape stops, an end-of-record gap is ALWAYS written. By this we mean, the register associated with the write system has been re-set to its original state. This is discussed in detail in the section on parity.

End-of-file gaps or marks may also be recognized by the stored program while reading a tape. This provides a useful way of separating large quantities of different kinds of information on tape.

Instructions are also available which will back-space the tape over a record or a file. No information may be written or read, however, when the tape is moving in a backward direction.

Except for a few milliseconds during starting or stopping, the magnetic tape is driven at the constant speed. The speed used varies between tape stations and is indicated in Table II. This speed is the same in either a forward or backward direction and is not affected, except in the case of a REWIND, by the select instruction which started the physical motion. When a REWIND instruction is given and if the tape is positioned more than 450 feet from its load point, a high-speed rewind occurs. The amount of tape to be rewound is measured automatically by a photocell mechanism in the tape unit. This high-speed rewind occurs in the average time of 1.2 minutes for a reel of tape from 450 to 2400 feet in length.

Figure 5 shows the aluminum strips used to indicate the load point (beginning of tape) and the physical end of tape. These reflective spots are photo-electrically sensed by the tape unit.

TWO-GAP READ-WRITE HEAD:

The 729 Magnetic Tape Unit provides two magnetic gaps for each of the seven recording tracks. One gap is used for writing and the other for reading. In the following discussion these heads will be referred to as the write gap and read gap.

This two-gap read write head (Figure 3) offers increased checking while writing. A tape that is being written passes first over the write gap (to record the data) and then over the read gap (to read what has been written). Thus, information which has been written is automatically read. Each lateral row of six bits and the longitudinal check bit for that row are analyzed. If any discrepancy occurred during the writing operation it will be detected at the read gap and a tape error will be indicated.

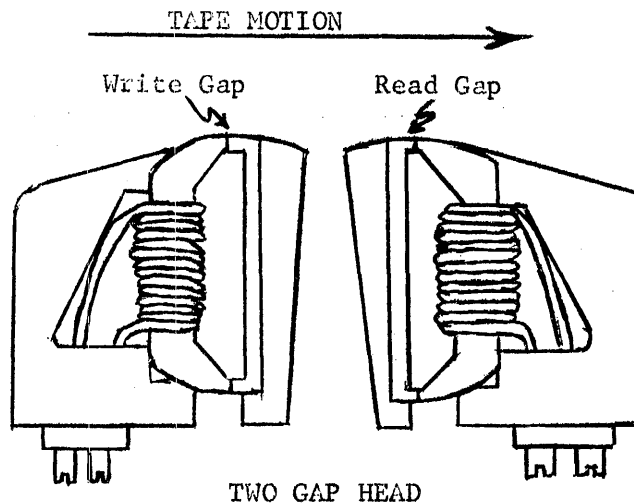

FIGURE 8

AUTOMATIC ERROR DETECTION AND REFECTION ON THE 729:

Dual-level sensing is used in the Tape Control Unit to increase discrepancy detection at the time of writing. Signals received by the checking circuitry associated with the read-write head are interpreted at two different energy levels (E1 and E2 in Figure 9). Random noise on the tape rising above the lower level will cause a parity discrepancy when signals are interpreted at the lower level (E1). A legitimate but weak signal which fails to reach E2 will cause a parity discrepancy when checked at the higher level. During writing, a tape check error will be turned on whenever a discrepancy is detected at either level. This indicator will also be turned on if the information received at both levels fails to catch bit for bit.

During reading, however, only parity bit discrepancies at both levels will indicate an error. If the signals sensed at one energy level show correct parity count, these signals are transmitted to core storage. The signals sensed at the other level and showing an incorrect parity count are automatically discarded. If both energy levels reveal an incorrect parity count the incorrect data at the E2 level will be transmitted to core storage and an error indication will be transmitted. The incorrect data from the E1 level will be discarded.

CHARACTER SIGNAL LEVELS

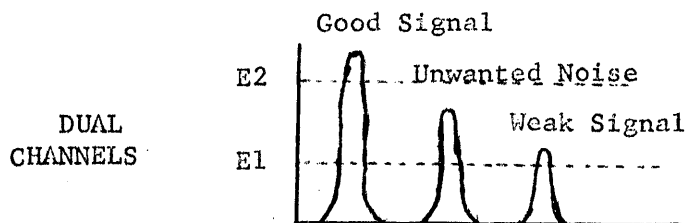

FIGURE 9.

Several milliseconds after a lateral row has been recorded on tape it will be read by the read gap and placed in both a HI and LO register in the Tape Control Unit. If any bit in the character is not strong enough, an error will be sensed in the HI register. If noise (Figure 9) strong enough to represent a bit is present, an error will be sensed in the LO register. The contents of the HI and LO registers are matched bit for bit to check for compensating errors. Any one of the three possible error conditions will turn on the tape error indicator. This indicator may be tested by the TRANSFER ON REDUNDANCY CHECK instruction for the Data Synchronizer.

When information is read from tape it is placed in the HI and Lo registers. If an error is sensed in the LO register, the contents of the HI register are transmitted to core storage. If an error is sensed in the HI register, the contents of the LO register are used. If both the registers show an error, the contents of the HI register are used and the tape error indicator for the Data Synchronizer is turned on. This indicator may be tested in the same manner as for the write operation.

MANUAL OPERATION OF THE TAPE UNITS:

On each tape unit, manual operations are performed by using the keys and lights. A rotary selector switch on a tape unit determines which one of the eight tape addresses may select this unit. If the switch is set to 1, the unit may be addressed.

The select light is turned on only when the calculator selects the tape unit. The tape unit is in ready status (the ready light is on), provided the tape is loaded into the columns, the reel door interlock is closed, and the tape unit is not in the process of finding the load point (rewind or load operation). Manual control is indicated when the ready light is off, provided the tape unit is not rewinding or loading and the reel door is closed.

Pressing the start key places the tape unit under control of the tape control unit (and, indirectly, the computer) and causes the ready light to be turned on, provided the tape unit is in ready status. Pressing the reset key removes the tape unit from the computer's control. It turns off the ready light, and resets all controls to their normal positions. It also stops any tape operation which has been initiated (except high-speed rewind, which will revert to low-speed rewind). After the tape is loaded into the vacuum columns and low-speed rewind is in progress, the reset key may be pressed again to stop the low-speed rewind.

When the door is open, the reel door interlock prevents operation of the reel drive motors. If the reel door is closed and the ready light is off, pressing the load-rewind key causes a fast rewind (if the tape is more than 450 feet from its load point) at the end of which the tape is loaded into the vacuum columns and searched in a backward direction for the load point.

Pressing the unload key causes the tape unit to remove the tape from the vacuum columns and raise the head cover, regardless of the distribution of the tape on the two reels. If the tape is not at the load point when the operator wishes to change it, he starts a load point search by pressing the load-rewind key.

The end-of-tape (eot) indicator in the Data Synchronizer is turned on when the tape breaks or when the physical end of tape is reached during a write operation. The END OF TAPE TEST may be used in a program to interrogate the status of the end-of-tape indicator in a data synchronizer. The status of the EOT indicator has no effect upon tape operation.

The end-of-tape indicator and light may be turned off by pressing the reset key on the tape unit and then pressing the unload key on the tape unit. Execution of the ETT instruction will turn off the EOT indicator in the data synchronizer.

The plastic tape reels are 10½ inches in diameter and are designed so that the front and back sides of the reel are different. In normal operation, a special ring is inserted in a groove in the back side of the reel to depress a pin which is then under spring tension. If the special ring is removed from the reel, the pin rides freely in this groove and a writing interlock is automatically set. Also, the file protection light is turned on to inform the program that it is possible for the program to write on tape. However, this tape may be read,backspaced, or rewound freely when the file protection light is on.

REFERENCES

- 1-. "Digital Computer Components & Circuits"
R. K. Richards; Van Nostrand (1957).
- 2-. "Magnetic Data Theory: Head Design", A. S. Hoagland
Communications and Electronics, Vol.27,pp. 506-512 (November 1956).
- 3-. "General Magnetic Recording Theory", Charles E. Lowman &
George J. Angerbauer, Ampex Instrumentation Products Co. (1961).
- 4-. "An Investigation of Pulse Detection", "Methods for Digital Recording"
Don F. Eldridge, Ampex Research Report 108, (January 1958).
- 5-. "A Study of Pulse Recording and Reproduction", Don F. Eldridge,
Ampex Research Report 112 (July 1958).
- 6-. "The Effects of Track Width on Recording System Performance",
Don F. Eldridge & Albert Baala, Ampex Research Report 114
(January 1958)
- 7-. "Magnetic Recording and Reproduction of Pulses", Don F. Eldridge,
National IRE Convention Record, Vol. 7, Part 9, pp. 141-159,
(1959).
- 8-. "High Density Recording Technique", A. S. Hogland & G. C. Bacon,
IRE Transactions on Electronic Computer, pp. 2-11, (March 1960).
- 9-. "Magnetic Tape for Data Recording", C. D. Mee, The Institution of
Electrical Engineers, Paper No. 2536M, (February 1958).
- 10-. "Bibliography of Magnetic Recording", Internal Ampex Document,
(1953 to 1962)
- 11-. "General Digital Theory Introduction", Ampex Training Department,
Digital Techniques Publications DT-1, C. A. Williamson (April 1962)
(Included in part as Appendix I).
- 12-. Requirements for compatability with IBM tape formats,
Don Halfhill, (January 1959)
- 13-. 7295V and 729VI Magnetic Tape Units Bulletin - IBM G22-6629-1,
(October 1961).
- 14-. IBMII, IV, V, VI Magnetic Tape Units - IBM A22-6643,
(December 1961)
- 15-. IBM 709, Reference Manual, IBM A22-6501-0.
- 16-. IBM Tape Adapter Unit, IBM 223-6847-1.

APPENDIX I

BINARY ARITHMETIC AND NUMBERS

1.0 NUMBER SYSTEMS

The number system which is in common use throughout the world today is the base ten system. There have been other number systems used by other civilizations. The Romans had their number system which today is used for such things as chapter numbering, building cornerstone dates and other applications where simple numbers are involved. This use is more traditional than practical. Other number systems such as the base 20 system of the Malayan civilization have fallen into disuse due to their complexity and have been discarded.

The base ten number system has ten allowable marks -- 0, 1, 2, 3, 4, 5, 6, 7, 8, 9. These marks are called Arabic numerals. The value or weight of a mark in a number depends solely upon the position it occupies with respect to other marks. That is, the value or weight of a mark is changed 10 fold every time it is moved one position to the right or left of a reference. If we more closely examine this system of tens, we can introduce a concept which will allow us to simplify the investigation. The concept is of a power or exponent. When we speak of raising a number by a power we really mean that we multiply it by itself as often as is indicated. For example, if we see 6^3 written we are expected to multiply $6 \times 6 \times 6$; 10^3 means $10 \times 10 \times 10$. We then speak of 6 to the 3 power or 10 to the 3 power. Since 10 is the base of our number system we can call the small number (3) our index or exponent which represents the number of zeros in the answer. Thus, for example, 1279 is a contraction of

$$\begin{array}{r r r r r} 1 & & \times & 1000 & (\text{or } 10^3) & = & 1000 \\ & 2 & & \times & 100 & (\text{or } 10^2) & = & 200 \\ & & 7 & & \times & 10 & (\text{or } 10^1) & = & 70 \\ & & & 9 & \times & 1 & (\text{or } 10^0) & = & \underline{9} \\ & & & & & & & & 1279 \end{array}$$

The operation just demonstrated requires no conscious thought process -- from constant daily use it has become second nature to us.

Let us consider another number system. This number system has only two allowable marks: 0 and 1. Let us, as we have done in the base ten

system, assign values or weights to various positions.

(27)	(26)	(25)	(24)	(23)	(22)	(21)	(20)
128,	64,	32,	16,	8,	4,	2,	1

In the base two number system each position changes in value by a factor of two, whereas, in the base ten system each position changes by a factor of ten. The method of indicating the value of a number is accomplished by the presence or absence of a 1. That is, the digit 2 is written in binary as 1 0, 5 as 1 0 1, and the digit 9 as 1 0 0 1. Now, if we wish to indicate the base ten number 1279, we can convert as follows:

1	x 1024 =	1024
0	x 512 =	0
0	x 256 =	0
1	x 128 =	128
1	x 64 =	64
1	x 32 =	32
1	x 16 =	16
1	x 8 =	8
1	x 4 =	4
1	x 2 =	2
1	x 1 =	1
<hr/>		
1 0 0 1 1 1 1 1 1 1	=	1279

or to write the binary equivalent of the base ten number 1279 requires 11 positions. Why has the binary number system come into use when it is so unwieldy? Equipment design for use with base ten numbers is many times larger because each position must be capable of 10 stable

To prove the answer we can multiply the position value by the marks contained in those positions

1	x	32	=	32			
1	x	16	=	16			
0	x	8	=	0			
1	x	4	=	4			
0	x	2	=	0			
0	x	1	=	0			
1	1	0	1	0	0	=	52

MULTIPLICATION

In multiplying two numbers we will be able to use the techniques developed in the addition of two numbers. Consider the multiplication of 38 by 5. As in the previous example we obtain our binary equivalent from Figure 2-3

1 0 0 1 1 0	=	38
x 1 0 1	=	x 5
1 0 0 1 1 0		
0 0 0 0 0 0		
1 0 0 1 1 0		

We then sum the rows and obtain our answer

1 0 0 1 1 0		
1 0 0 1 1 0		
1 0 1 1 1 1 1 0	=	190

Converting to a base ten number

1	x	128	=	128
0	x	64	=	0
1	x	32	=	32
1	x	16	=	16
1	x	8	=	8
1	x	4	=	4
1	x	2	=	2
0	x	1	=	0
1 0 1 1 1 1 1 0			=	190

It is best to add two rows at a time. However, since our answer contained a row of all zeros we eliminated this row and added the remaining rows in accordance with our rules for addition.

SUBTRACTION

The simple direct subtraction of binary numbers is accomplished in much the same manner as addition. In general, when subtracting two digits, one from the other, each digit of the minuend is decreased by the amount of the corresponding digit of the subtrahend. If the minuend digit thereby becomes less than zero, the minuend digit of the next higher order must be reduced by one; that is, a 1 must be "borrowed" from the next higher order. The rules of direct subtraction are shown in Figure 2-2.

Minuend Digit	0	1	0	1
Subtrahend Digit	0	0	1	1
Difference Digit	0	1	1	0
Borrow	0	0	1	0

Figure 2-2

When we borrow a one from a next higher position our number for the position then becomes two. Since there is no mark for two in the binary system, two is written 1 0.

What is meant by 0 - 1 = 1 borrow 1 in column 3 of Figure 2-2 is:

$$\begin{array}{r}
 0 \\
 1 \ 0 \quad 1 \ 0 = 2 \text{ base 10 number} \\
 - 0 \ 1 \quad - 1 = 1 \text{ base 10 number} \\
 \hline
 0 \ 1 = 1 \text{ base 10 number}
 \end{array}$$

Now if we wish to subtract 15 from 37, we obtain our binary equivalent number from Figure 2-3 and subtract according to the rule of Figure 2-2.

$$\begin{array}{r}
 1 \ 1 \ 1 \ 0 \\
 1 \ 0 \ 0 \ 1 \ 0 \ 1 = 37 \text{ base 10 number} \\
 - 1 \ 1 \ 1 \ 1 = -15 \text{ base 10 number} \\
 \hline
 1 \ 0 \ 1 \ 1 \ 0 = 22 \text{ base 10 number}
 \end{array}$$

1	1	22	10110	43	101011
2	010	23	10111	44	101100
3	011	24	11000	45	101101
4	100	25	11001	46	101110
5	101	26	11010	47	101111
6	110	27	11011	48	110000
7	111	28	11100	49	110001
8	1000	29	11101	50	110010
9	1001	30	11110	51	110011
10	1010	31	11111	52	110100
11	1011	32	100000	53	110101
12	1100	33	100001	54	110110
13	1101	34	100010	55	110111
14	1110	35	100011	56	111000
15	1111	36	100100	57	111001
16	10000	37	100101	58	111010
17	10001	38	100110	59	111011
18	10010	39	100111	60	111100
19	10011	40	101000	61	111101
20	10100	41	101001	62	111110
21	10101	42	101010	63	111111

Figure 2-3

Basic Principles of Boolean Algebra

In Boolean algebra, there are only two different quantities or values which come into consideration and these quantities are 0 and 1. Arithmetic operations in Boolean algebra with "numbers" which can be only 0 or 1 bear little resemblance in meaning to the arithmetic operations in ordinary algebra, although in many instances the rules for performing the operations are the same. In particular, addition will be assigned the meaning of "OR" and multiplication has the meaning of "AND". The results obtained when "adding" and "multiplying" the various combinations of 0's and 1's are as follows:

$0 + 0 = 0$	$0 \times 0 = 0$
$0 + 1 = 1$	$0 \times 1 = 0$
$1 + 0 = 1$	$1 \times 0 = 0$
$1 + 1 = 1$	$1 \times 1 = 1$

The first equation involving "addition" has the meaning, "0 OR 0 is equal to 0". The second equation has the meaning "0 OR 1 is equal to 1" because the OR function, as indicated by the plus sign, serves to signify that the resultant quantity is 1 if either of the given quantities is 1. This interpretation of the OR function includes the case where both of the given quantities are 1; therefore, "1 OR 1 is equal to 1". Since there is no such quantity as 2 in Boolean algebra, the latter equation is, of necessity, different from anything found in ordinary algebra. A simple example of the Boolean algebra OR function would be a fire-alarm device which may be actuated by signals from two different sources. The signal from each source may be represented by a 1, and the absence of a signal may be represented by a 0. The signal lines from the two sources should be combined so that the alarm will sound whenever a signal is received from either source. In other words, a signal is sent to the alarm when a signal is received from one source OR the other source. Of course, if signals are received from both sources simultaneously, the alarm will sound in this case also, but not with twice the amplitude.

The equations involving "multiplication" have corresponding meanings, but with the word "AND" substituted for "OR". The AND signifies that the resultant quantity is 1 only when both of the given quantities are 1. The last equation, which states that "1 AND 1 is equal to 1" should not be confused with addition or ordinary algebra. An elementary example of an AND function would be the firing of an explosive charge through the use of two signals where, in the interest of safety, it is required that both signals be present simultaneously in order to cause the charge to explode. The charge will explode only when a signal is received from one source AND the other source also.

As in ordinary algebra, symbols may be used to represent "unknowns" or "variables", although the range of variation is limited to one or the other of the two discrete quantities, 0 and 1. The symbolic equation $C = A + B$, for example, means that C is 1 if A OR B is 1 (or if both are 1); otherwise, C is 0. Similarly, the equation $C = AB$ means that C is 1 only if both A AND B are 1; otherwise, C is 0.

Application to Digital Components

The bare rules of Boolean algebra, as described in the previous section, probably seem somewhat artificial and pointless when considered by themselves, but their meaning and application should become more understandable when the correlation between the functions and digital components is described in more detail.

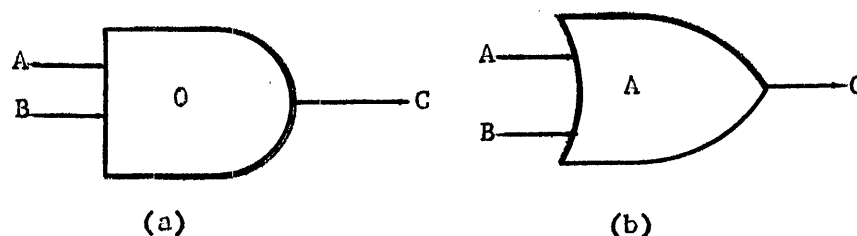

Figure 3-1

The OR switch may have any number of inputs, and each input will be indicated by a separate line. The output from the switch correspondingly will be represented by a line, as indicated in Figure 3-1 (a). If the input signals to a two-input OR switch are represented by the variables, A and B, and the output by C, the functional relationship between the output and the inputs may be designated by the equation, $C = A + B$. Of course the input variables are always the independent variables, with the output being dependent upon the inputs. Again, each variable is either 1 or 0, according to the presence or absence of a signal on its corresponding line. The equation, therefore, has the meaning that a signal will be present on line C if a signal is present on line A "OR" on line B (or both).

A simple AND switch will be similarly symbolized, as shown with two inputs in Figure 3-1 (b). In the case of the AND switch, the functional dependence of the output C, expressed in terms of inputs, A and B, may be represented by the equation, $C = AB$. The meaning of the equation is that C is 1 only when both A AND B are 1.

The importance and usefulness of Boolean algebra notation can be seen from an application of the fundamentals just discussed. Consider the requirement of producing an output when inputs A AND B are 1, or when inputs C AND D are 1. This requirement can be expressed in Boolean notation as $E = AB + CD$ and the switching network which will perform this is illustrated in Figure 3-2.

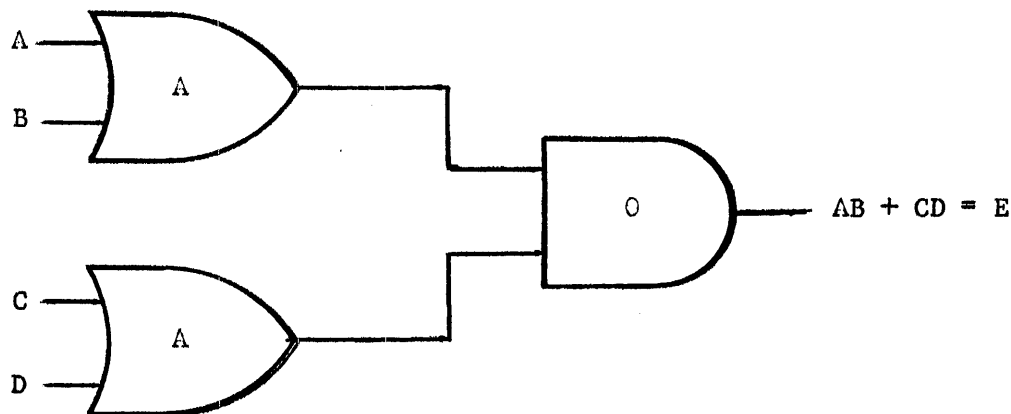
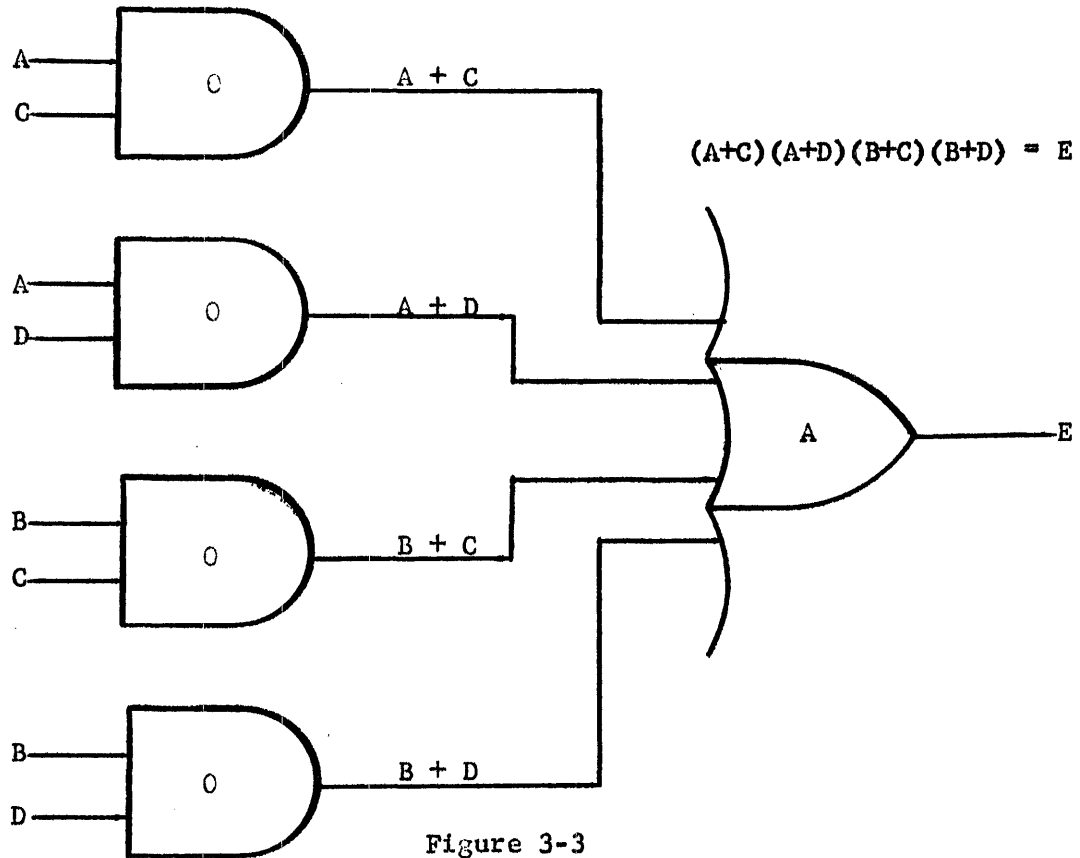

Figure 3-2

However, it is possible to write down the desired switching function in other ways. One other way is indicated by

$$(A + C) (A + D) (B + C) (B + D) = E$$

and is identical to $E = AB + CD$. The switching network of Figure 3-3 illustrates this approach.



When OR and AND gates are fabricated from diodes, the number of diodes contained within any given gate is equal to the number of inputs. Therefore, a total of 6 diodes is required for the switching network of Figure 3-2, and 12 diodes are required for the network in Figure 3-3.

If the switching circuit given in Figure 3-3 had been given first, a reduction in the required number of diodes could have been achieved merely by performing algebraic manipulations without any consideration to the switching circuits themselves.

In the previous examples we considered only the AND and OR functions. It is often necessary that a function be inverted so that when an input is present another function does not occur. The AND gate output results in an output only when all of the inputs are coincident and are true. Such a circuit, when combined with an inverter becomes an anti-coincident gate. Such circuits are also referred to as NOT AND and NAN gates. Examples of these circuits are shown in Figure 3-4. Figure 3-4 (a) indicates the AND and NOT circuit combinations.

It is also possible to combine the OR and NOT circuit as is shown in Figure 3-4 (b). Such combinations are called NOR gates and produce a false or zero output when any or all of the inputs are 1 or true.

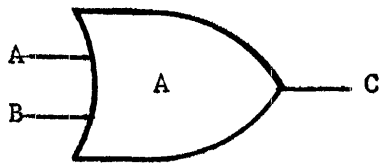

(a)

$$C = \overline{AB}$$

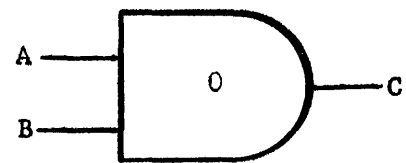

(b)

$$C = \overline{A + B}$$

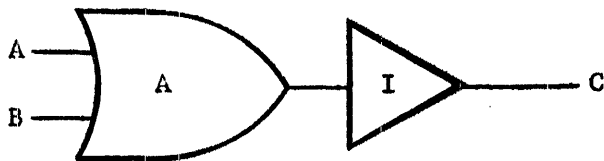

(c)

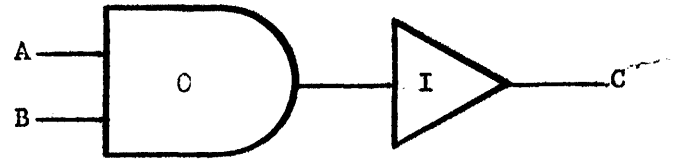

(d)

Figure 3-4

A possible method of construction of the NOR gate of Figure 3-4 (a) is shown in Figure 3-4 (c). Likewise a possible method of constructing the OR of 3-4 (b) is shown in 3-4 (d) above.

Another basic digital building block used in switching networks is the inhibited OR gate. This logic element finds application where it

is desired to prevent an output in the presence of an input occurring during an event taking place in another part of the system. Such a block is shown in Figure 3-5 (a). An OR is combined with a NOT and an AND in Figure 3-5 (b).

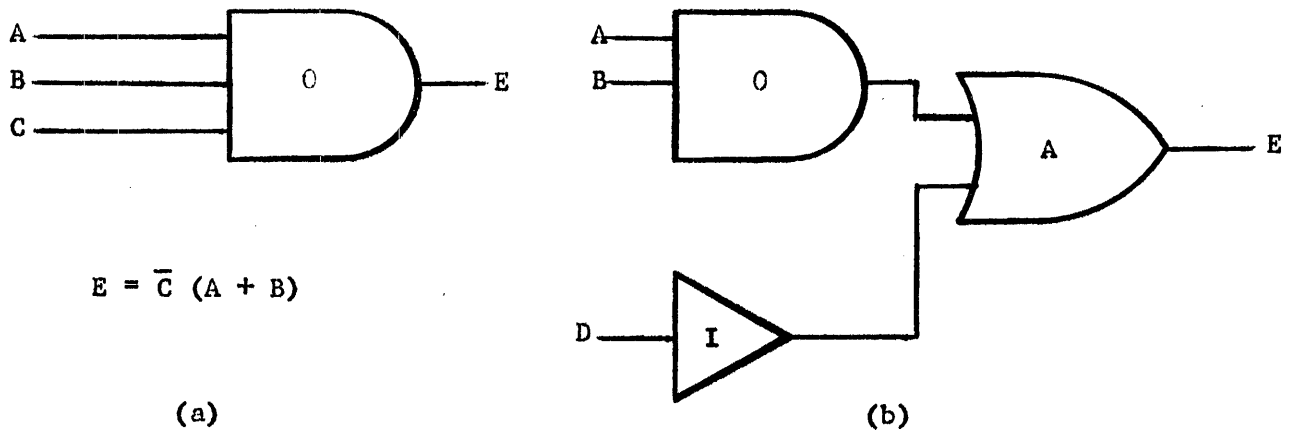

Figure 3-5

The arrangement of Figure 3-5 (b) is one possible method of producing the results desired.

APPENDIX II

IBM MAGNETIC TAPE SPECIFICATIONS

The following specifications pertain to both Mylar* and Cellulose Acetate base tapes. (Durexcel tape has a specially formulated, long-life, magnetic coating on a Mylar base.)

1. Materials to be as follows: Tape to consist of a base material coated on one side with a strong yet flexible layer of ferromagnetic material dispersed in a suitable binder.

Tape Dimensions to be as follows: Tapes of various lengths may be used. Up to 1200' length tolerance to be plus 20' minus 0'. Greater than 1200' length tolerance to be plus 50' minus 0'. Maximum nominal length to be 2400'. Width of the tape to be 0.498 of an inch with a limit of plus or minus 0.0002 of an inch. Total thickness for all tape to be 0.0019 of an inch with a tolerance of plus or minus 0.0002 of an inch with a base material thickness of 0.00145 of an inch plus or minus 10%. Longitudinal curvature to be less than 3/8 of an inch per 36 inches of tape; measurement to be made with magnetic oxide surface and the tape, placed on a flat surface, permitted to assume its natural curvature.

Physical Requirements to be as follows:

Magnetic oxide surface to be free of raised areas, holes or any foreign matter. Surface of base material to be free of powder or accumulation of deleterious matter which would cause incorrect operation or necessitate increased servicing of the machines. Tape not to be spliced.

Acetate Tape: Tensile strength to be a minimum of 8 pounds.

Elastic elongation under 5 pounds tension to be less than 1.5%. Change in width of tape due to a change in relative humidity and temperature within the operating limits (3) to be less than 0.40%.

Mylar Tape: Tensile strength to be a minimum of 12 pounds. Elastic elongation under 5 pounds tension to be less than 1.5%.

Change in width of tape due to a change in relative humidity and temperature within the operating limits (3) to be less than 0.30%.

The above "Tape Dimensions" and "Physical Requirements" are based on measurements made under the following conditions:

- a) Tape to be rewound a minimum of three times in succession with less than 1.5 pounds tension in a room conditioned at 65° to 75° Fahrenheit and 45% to 55% relative humidity.
 - b) Tape to be kept under these conditions a minimum of 24 hours before tests are made.
2. Magnetic Performance: Magnetic performance to be measured with a recording head which conforms to the following specifications:
 - a) Recording head to consist of 7 parallel channels.

*DuPont's registered trademark for its polyester film.

2/MAGNETIC TAPE SPECIFICATIONS

- b) Track width to be 0.0320 of an inch with a tolerance of plus zero inches or minimum 0.0005 of an inch and a channel spacing between centers of tracks to be 0.0700 of an inch with a limit of plus or minus 0.0003 of an inch.
- c) Center line of Track 1 to be 0.040 of an inch with a limit of plus or minus 0.001 of an inch from edge of tape.
- d) Recording gap length to be 0.0005 of an inch with a limit of plus or minus 10% and perpendicular to direction of tape travel.
- e) Recording head to be tapered 6 with a limit of plus or minus 0.5 downward from the horizontal plane.

Average peak output as referred to in these specifications means the average amplitude of the voltage envelope of a minimum of 100 pulses sensed by the recording head operated in contact with magnetic tape moving at a speed of 75 inches per second, having a square wave recorded on it at saturation (Non-Return to Zero recording method) and a bit density of 200 bits per linear inch.

The coercive force shall not exceed 280 oersteds.

The average peak output of a magnetic tape when compared to an IBM Test Tape shall not vary more than 5% from the average peak output of the IBM Test Tape.

No dropout of signal to occur with resultant output less than 50% of average peak output. No noise signal to be greater than 10% of average peak output level. When testing for noise, tape to be saturated in one direction. When stored at 150 Fahrenheit for 8 hours, no transfer of signals to occur between layers greater than 1% of average peak output.

- 3. Operating Limits: Acetate Tape to be used in area where the relative humidity is in the range 40% to 60% and temperature from 65° to 80° Fahrenheit. Mylar may be used in area where relative humidity is not controlled and temperature is in a range from 40° to 120° Fahrenheit.

4. Storage:

Acetate Tape: After prolonged storage under controlled temperature 60° to 80° Fahrenheit and 40% to 60% relative humidity, no deterioration of magnetic oxide, binder or base to take place which will prevent the magnetic tape from meeting these specifications.

Mylar Tape: After prolonged storage under controlled temperature 40° to 120° Fahrenheit and 0% to 75% relative humidity, no deterioration of magnetic oxide, binder or base to take place, which will prevent the magnetic tape from meeting these specifications.

- 5. Markets: Photo-sensing markets to be attached to magnetic tape as follows:

- a) Photo-sensing market to be not less than 1 inch in length, Width of market to 3/16 of an inch with a limit of plus or minus 1/64 of an inch. Market to consist of a transparent

3/MAGNETIC TAPE SPECIFICATIONS

plastic base material with a uniform thickness of 0.0005 of an inch with a limit of plus or minus 0.0001 of an inch. Vaporized aluminum coating to be sandwiched between the base and a thin layer of a pressure-sensitive, thermal setting, low cold flow adhesive.

Markers to be attached to base (uncoated) side of tape with the 1 inch dimension parallel to edge of tape. One marker to be placed 14 feet with a tolerance of plus 1 foot or minus zero feet from end of tape nearest hub of reel. Marker to be not more than 1/32 of an inch from Track C edge of tape. A second marker to be attached 10 feet with a tolerance of plus 1 foot or minus zero feet from other end of tape. This marker to be not more than 1/32 of an inch from Track 1 edge of tape. Markers not to extend beyond edge of tape. Markers to be firmly attached to tape and free of wrinkles. No adhesive material to extend beyond edges of markers.

- b) Grounding leader (required for IBM Type 726 Magnetic Tape Unit) to be of non-magnetic stainless steel, 36 inches, in length. Edges to be broken and free of burrs. Width to be 0.495 of an inch with a limit of plus or minus 0.002 of an inch. Thickness to be 0.0017 of an inch with a limit of plus or minus 0.0002 of an inch.

End of tape nearest hub of reel to be butt joined to leader and secured on base side of tape by approximately 1 inch of an oil resistant polyester film with a thin layer of a pressure-sensitive, thermal setting, low cold flow adhesive. Tensile strength of joint to be a minimum of 3 pounds. No adhesive material to extend beyond edges of leader or tape. Other end of leader to be suitable for secure connection to grounding pin in reel hub.

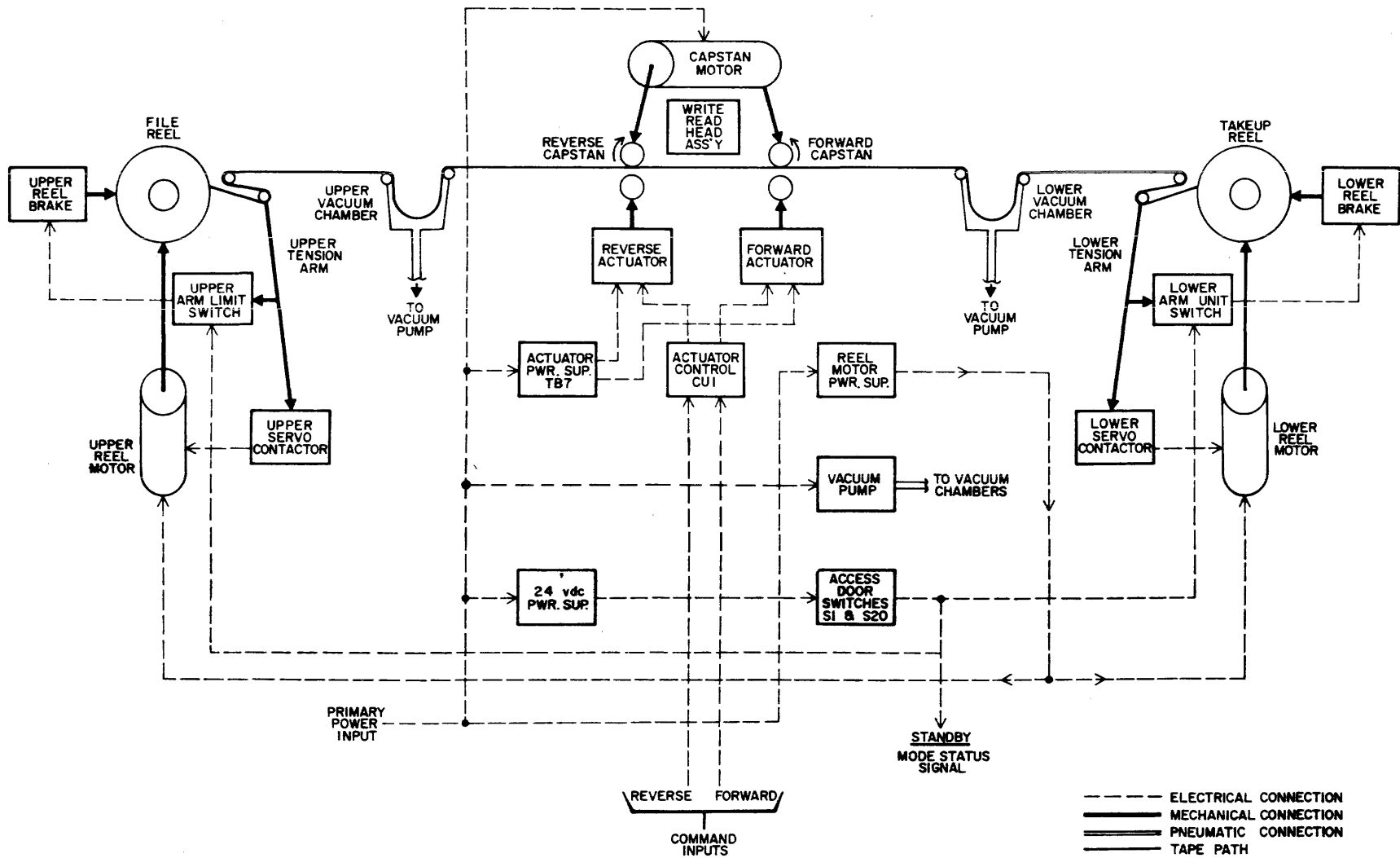

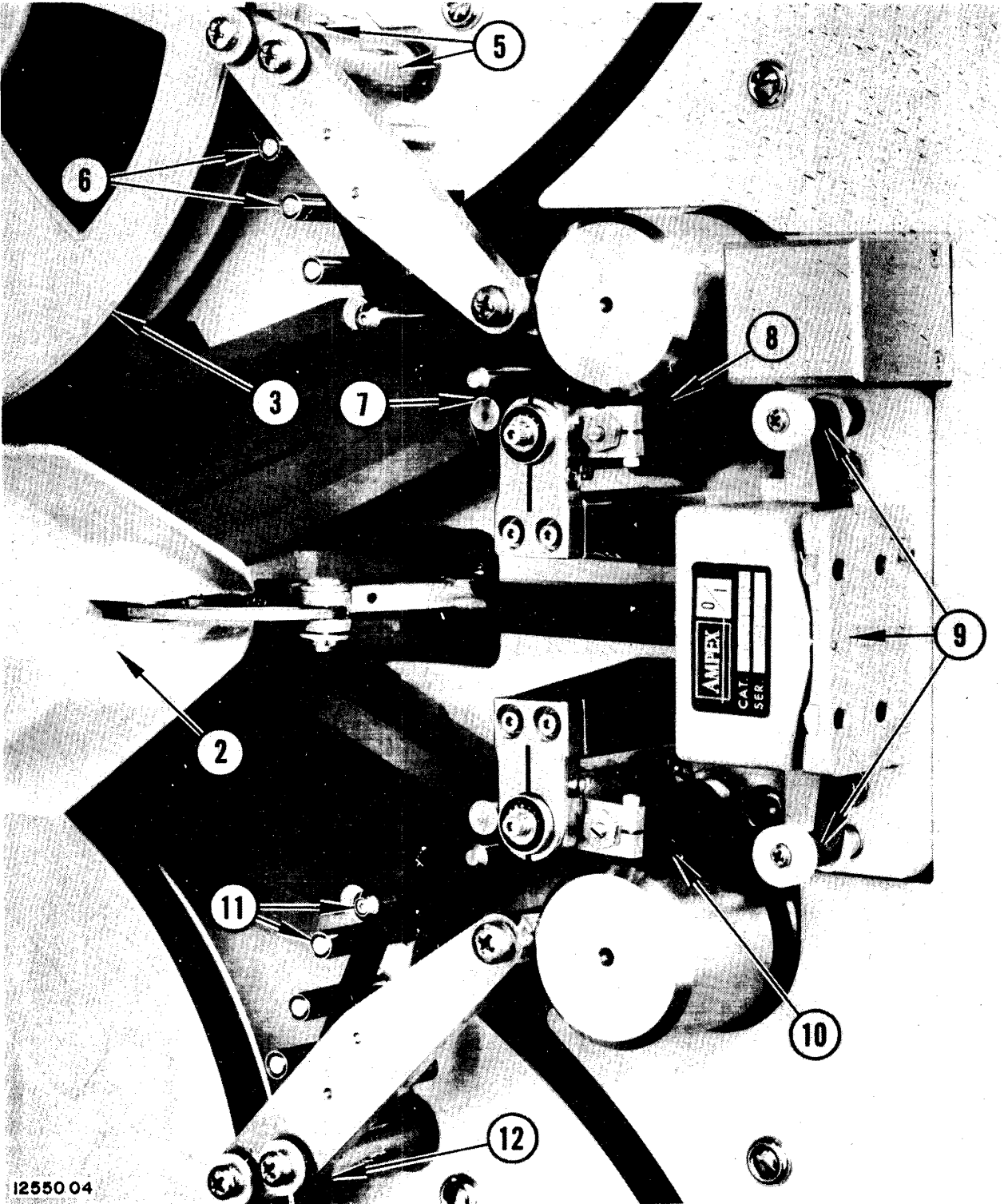

12550 04

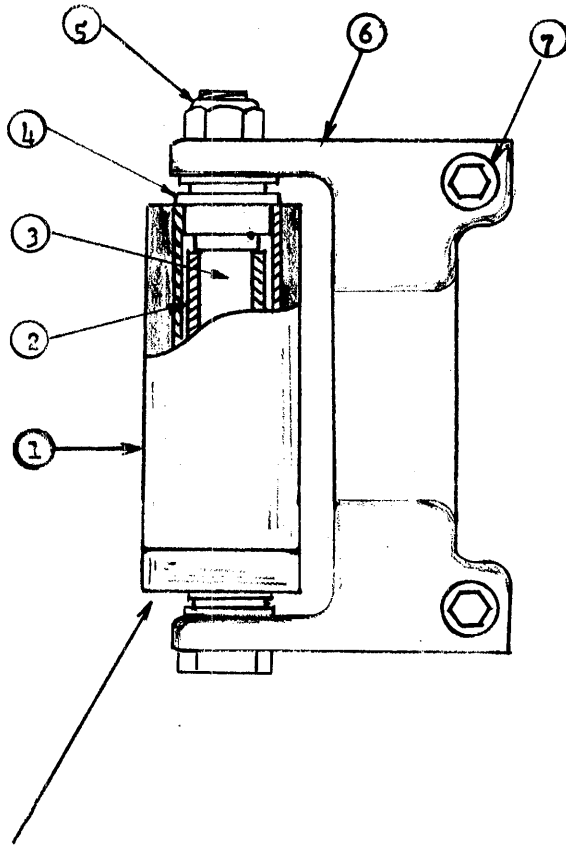

- 03 AS SHOWN (METAL PORTION OF ROLLER THIS END)
- 04 OPPOSITE HAND

FR-400

PINCH ROLLER ASSEMBLY

PART No. 60939 - 03; - 04

CONTAINING:

- 1 (1) 60945-01 PINCH ROLLER MOLDED ASSEMBLY
- 1 (2) 64727-1 SPACER - SLEEVE
- 1 (3) 60943-01 SHAFT, PINCH ROLLER
- 2 (4) 421-064 BEARING, FLANGED BALL
- 1 (5) 493-015 NUT, SELF LOCKING
- 1 (6) 60940-02 YOKE ASSEMBLY
- 2 (7) 470-010 SCREW, 4-40 x 3/8, HEX SOC. HD.

3-3

rjb

Pinch Roller Assembly

PINCH ROLLER ACTUATOR

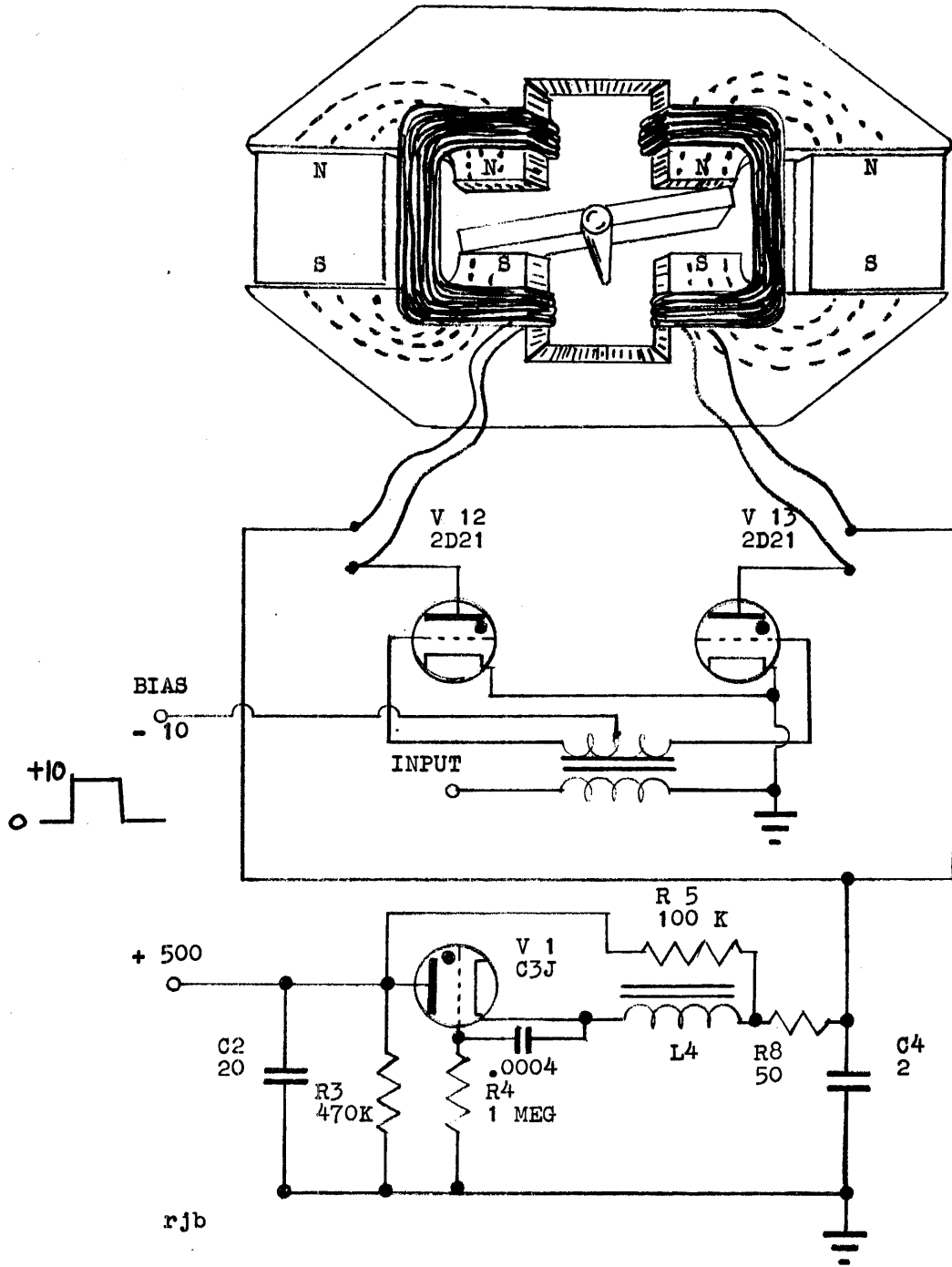

3-2

Pinch Roller Actuator System

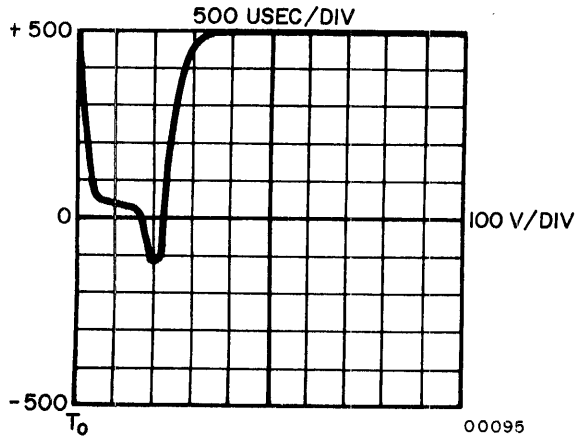

VOLTAGE WAVEFORM
ANODE V12

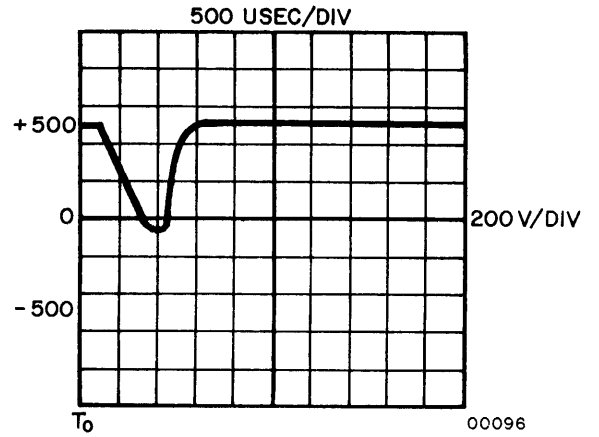

VOLTAGE WAVEFORM
CAPACITOR C4

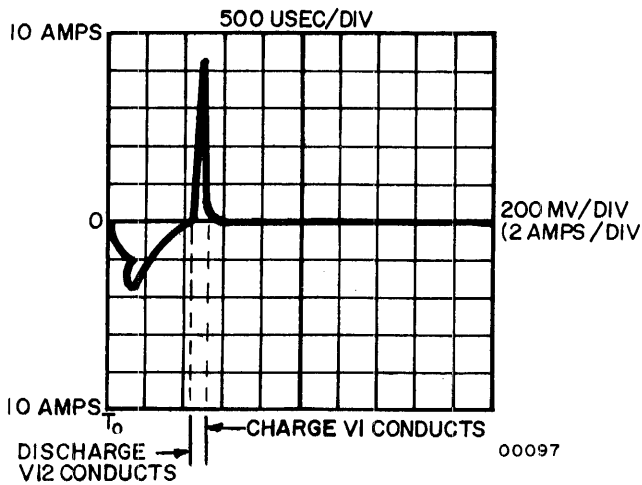

CURRENT WAVEFORM
DISCHARGE AND CHARGE OF C4

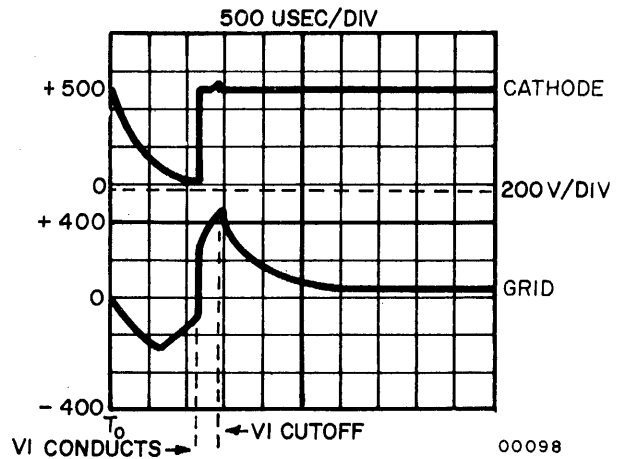

VOLTAGE WAVEFORMS
CATHODE AND GRID OF V1

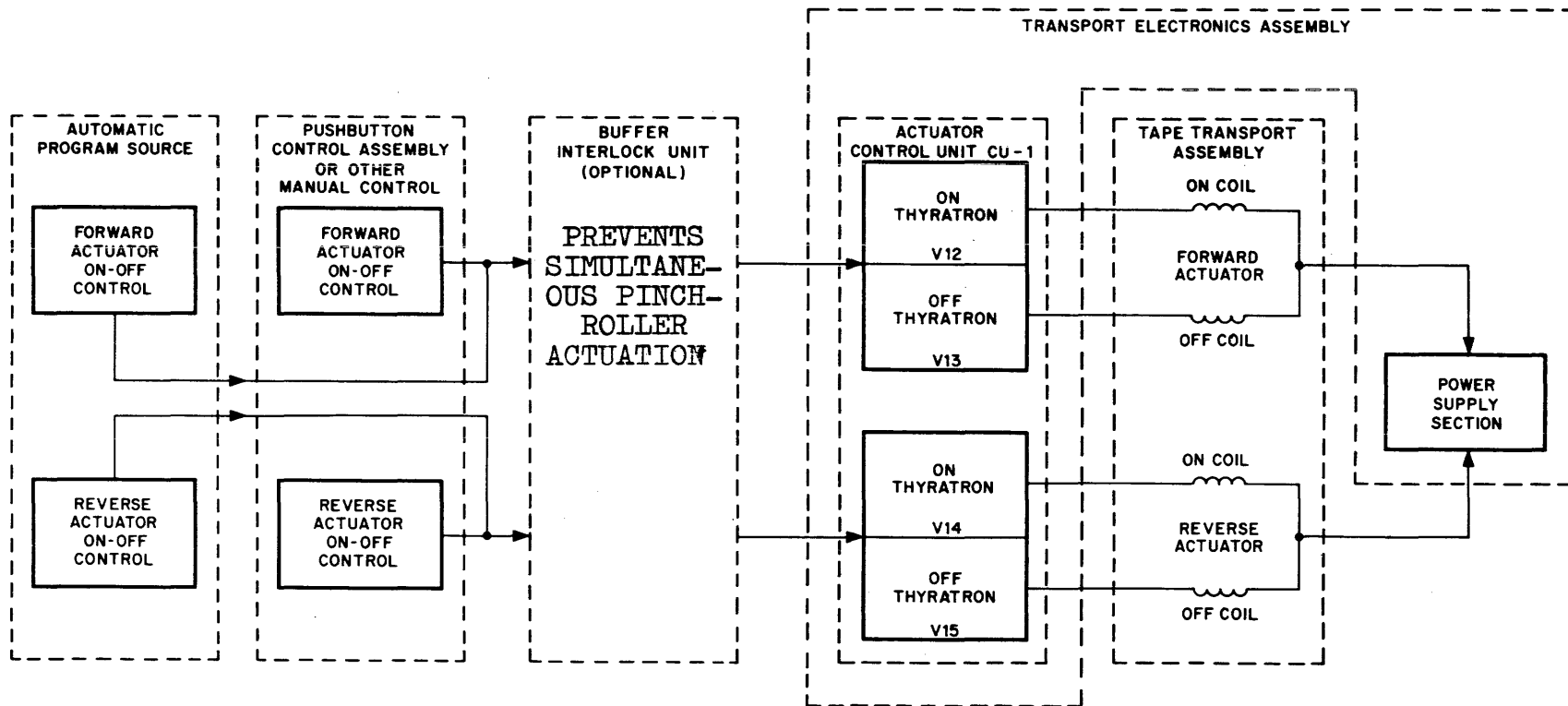

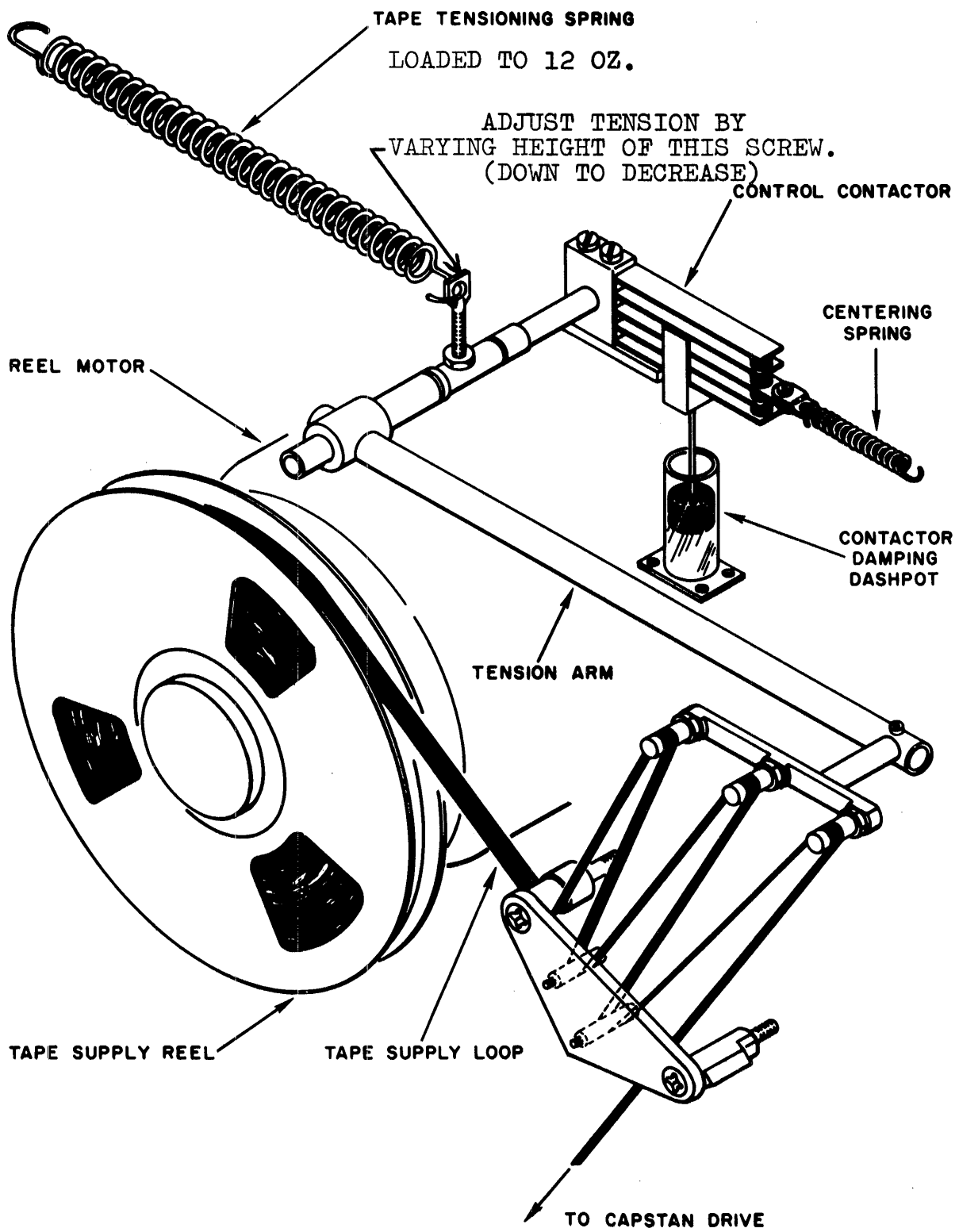

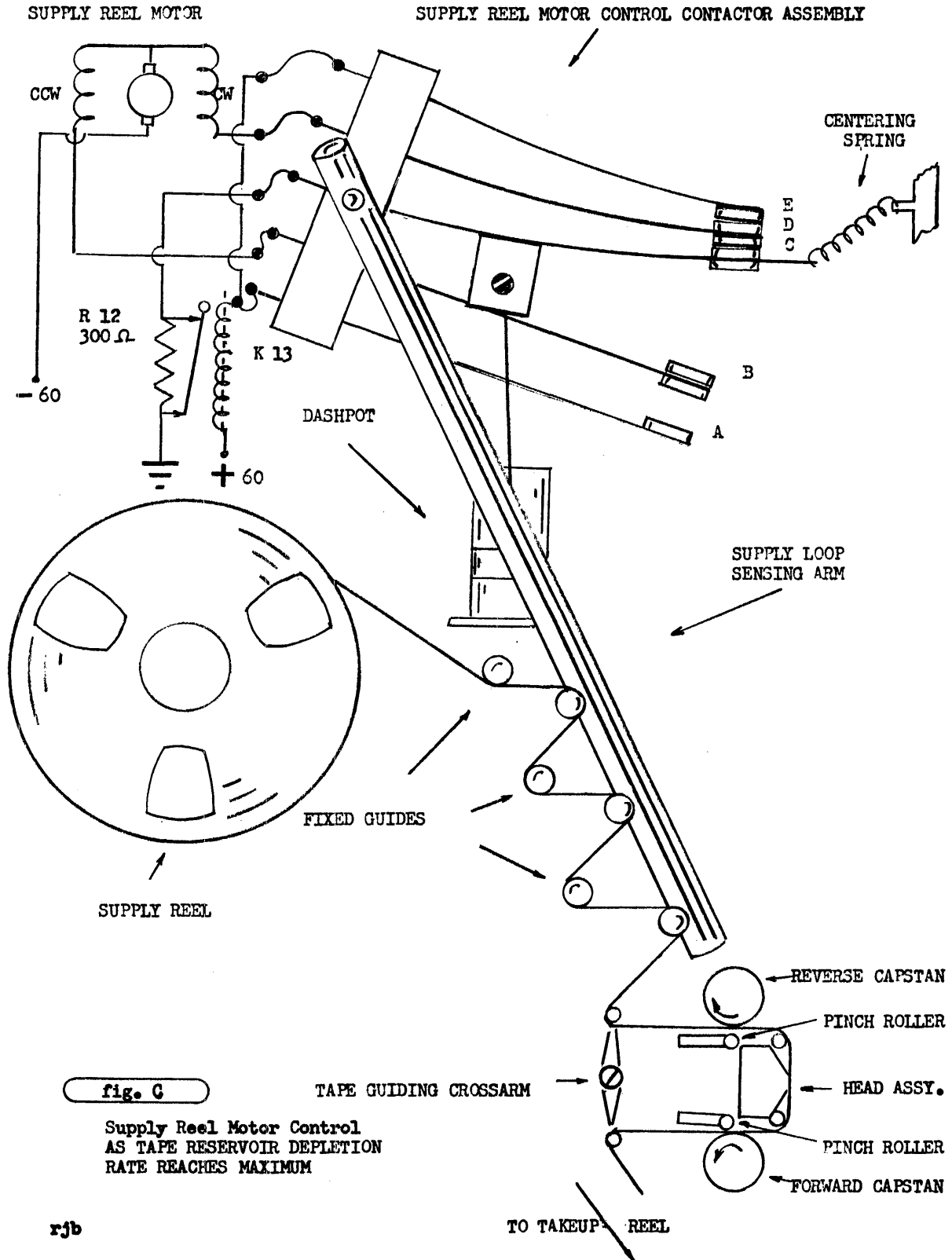

rjb

SUPPLY REEL MOTOR

SUPPLY REEL MOTOR CONTROL CONTACTOR ASSEMBLY

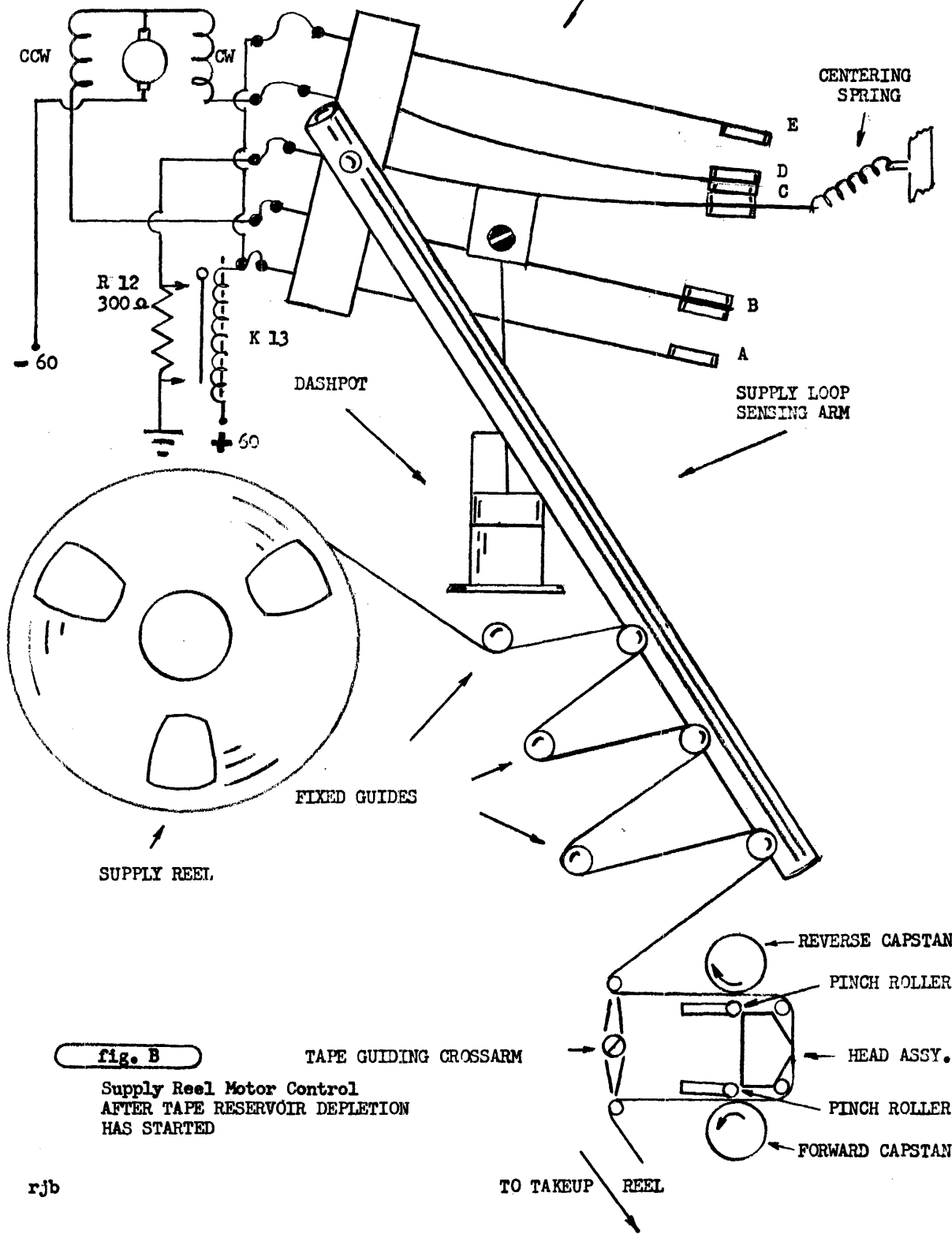

fig. B

TAPE GUIDING CROSSARM

Supply Reel Motor Control
AFTER TAPE RESERVOIR DEPLETION
HAS STARTED

rjb

TO TAKEUP REEL

SUPPLY REEL MOTOR

SUPPLY REEL MOTOR CONTROL CONTACTOR ASSEMBLY

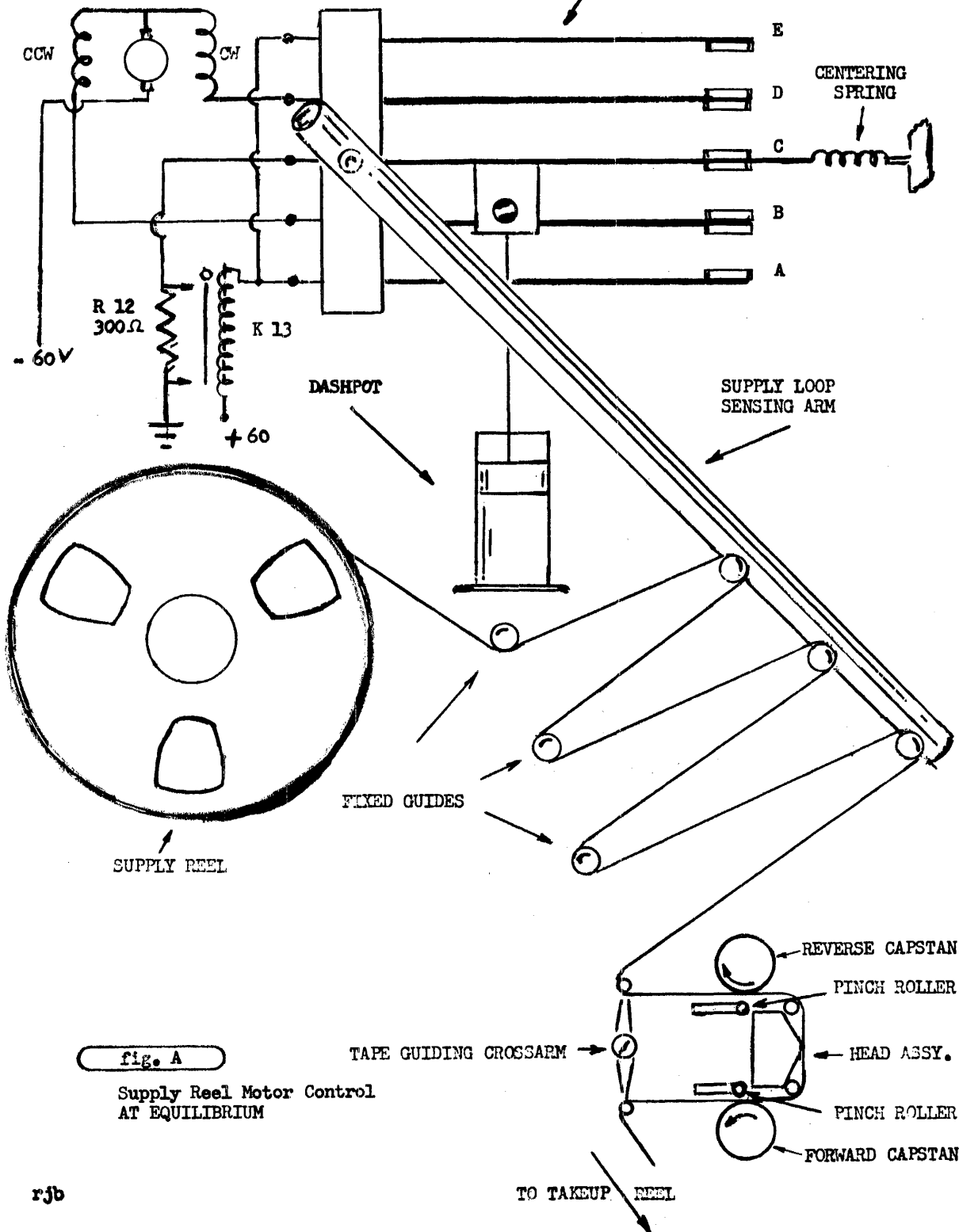
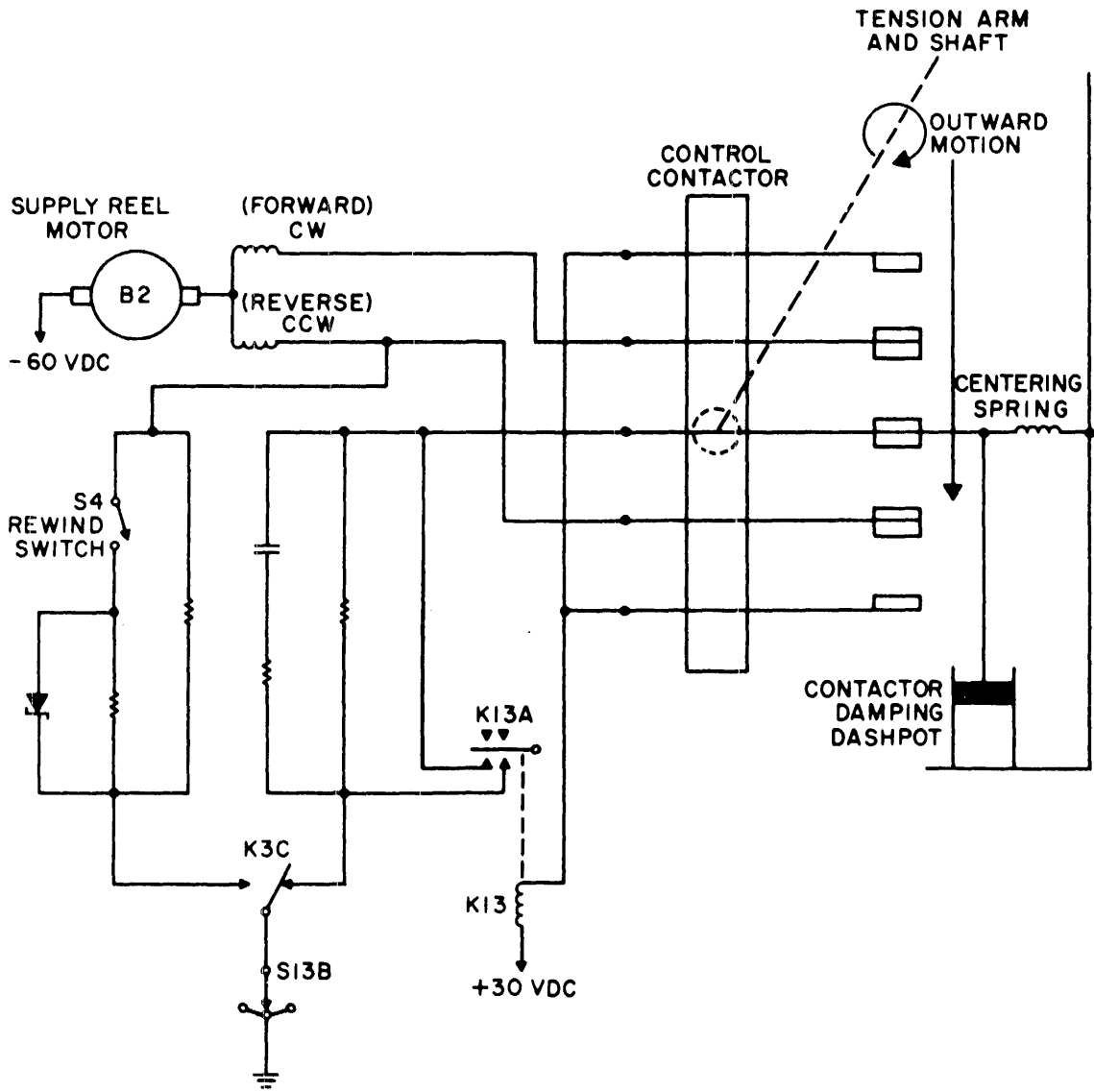
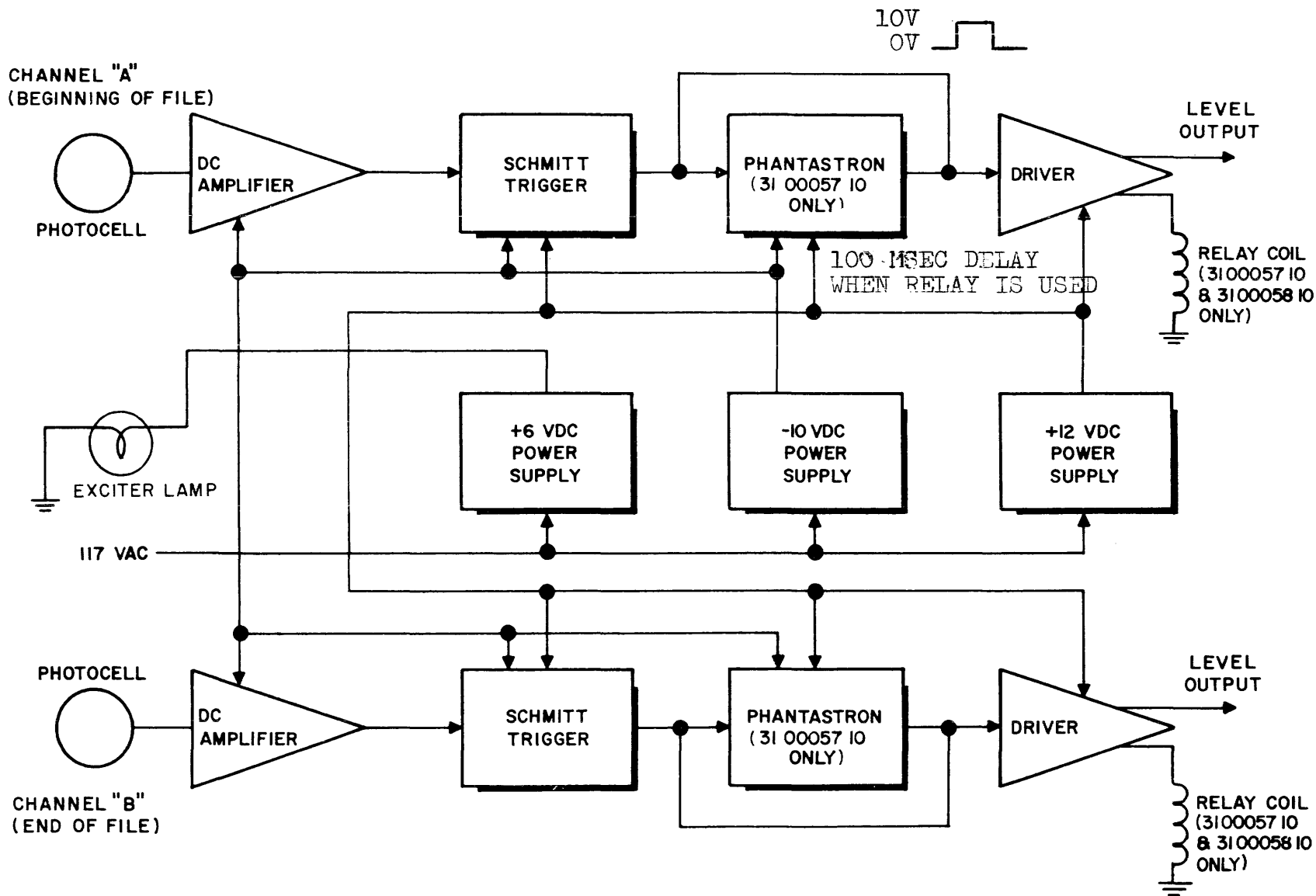

fig. A

Supply Reel Motor Control AT EQUILIBRIUM

rjb





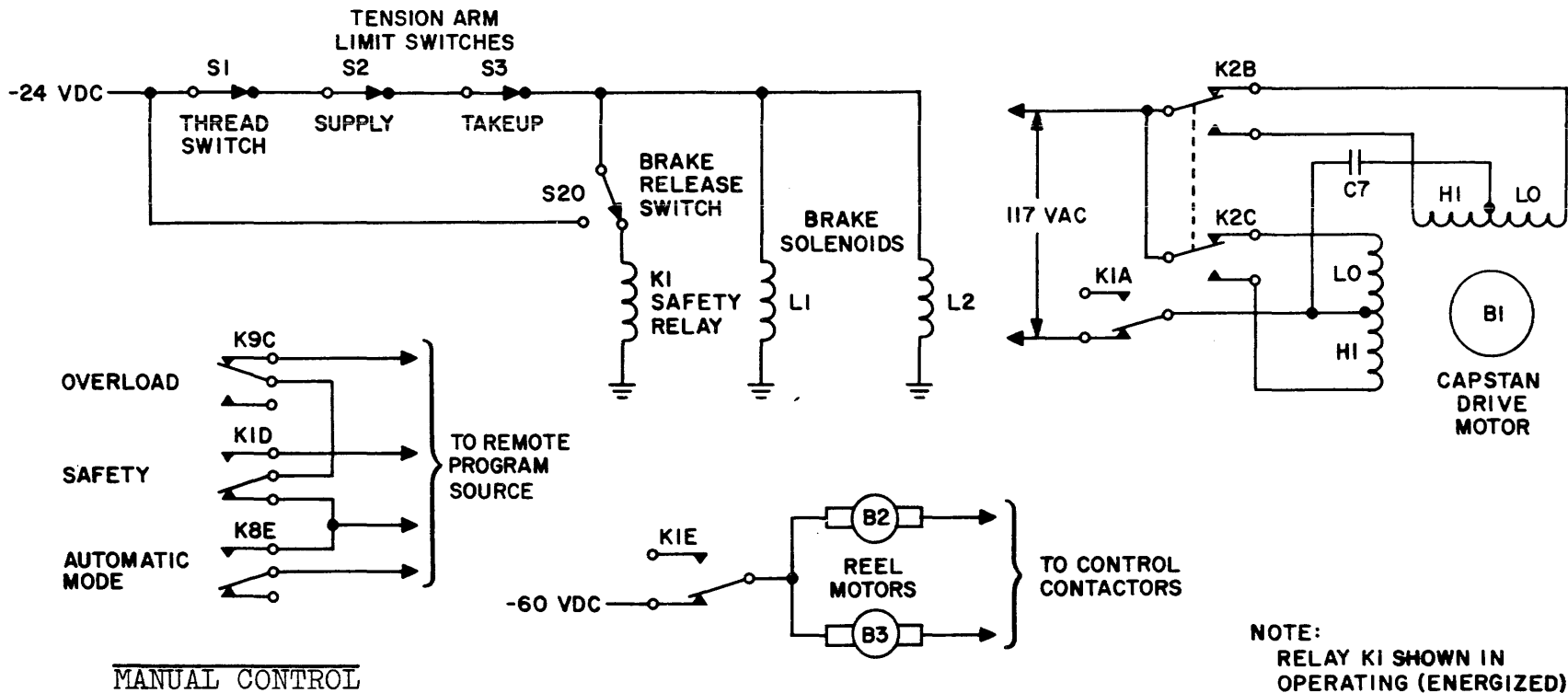

NOTE:
RELAY KI SHOWN IN
OPERATING (ENERGIZED)
POSITION.

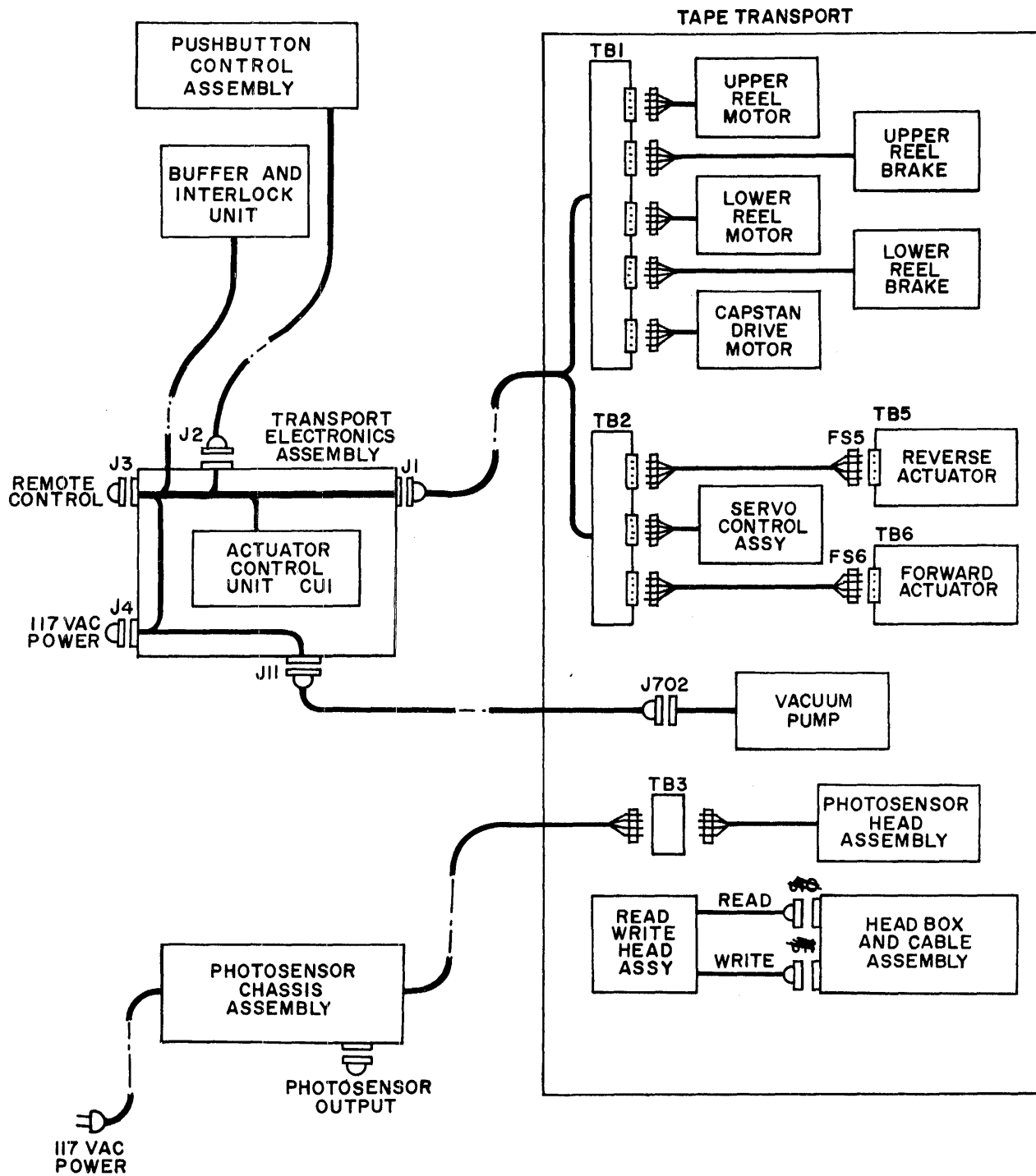

- 1. UNLESS OTHERWISE SPECIFIED:
 ALL DIODES ARE IN 2063.
 ALL RESISTORS IN OHMS
 ALL CAPACITORS IN MICROFARADS
 ALL RELAYS SHOWN IN DEENERGIZED POSITION

- 2. S1 IS SHOWN IN A POSITION WHEN THE MACHINE IS IN AN OPERATING CONDITION
- 3. RED WIRES CARRY -60V D.C.
 YEL WIRES CARRY -24V D.C.
 BRN WIRES CARRY 117V A.C.
 BRN & WHT TWISTED WIRES CARRY LINE VOLTAGE
 BLACK WIRES ARE GRD RETURNS.

- 4. DOT "•" DENOTES LOWER CASE LETTERS
- 5. ALL GROUND CONNECTIONS (⊥) ARE CONNECTED TO A POINT NEAR TS15-1

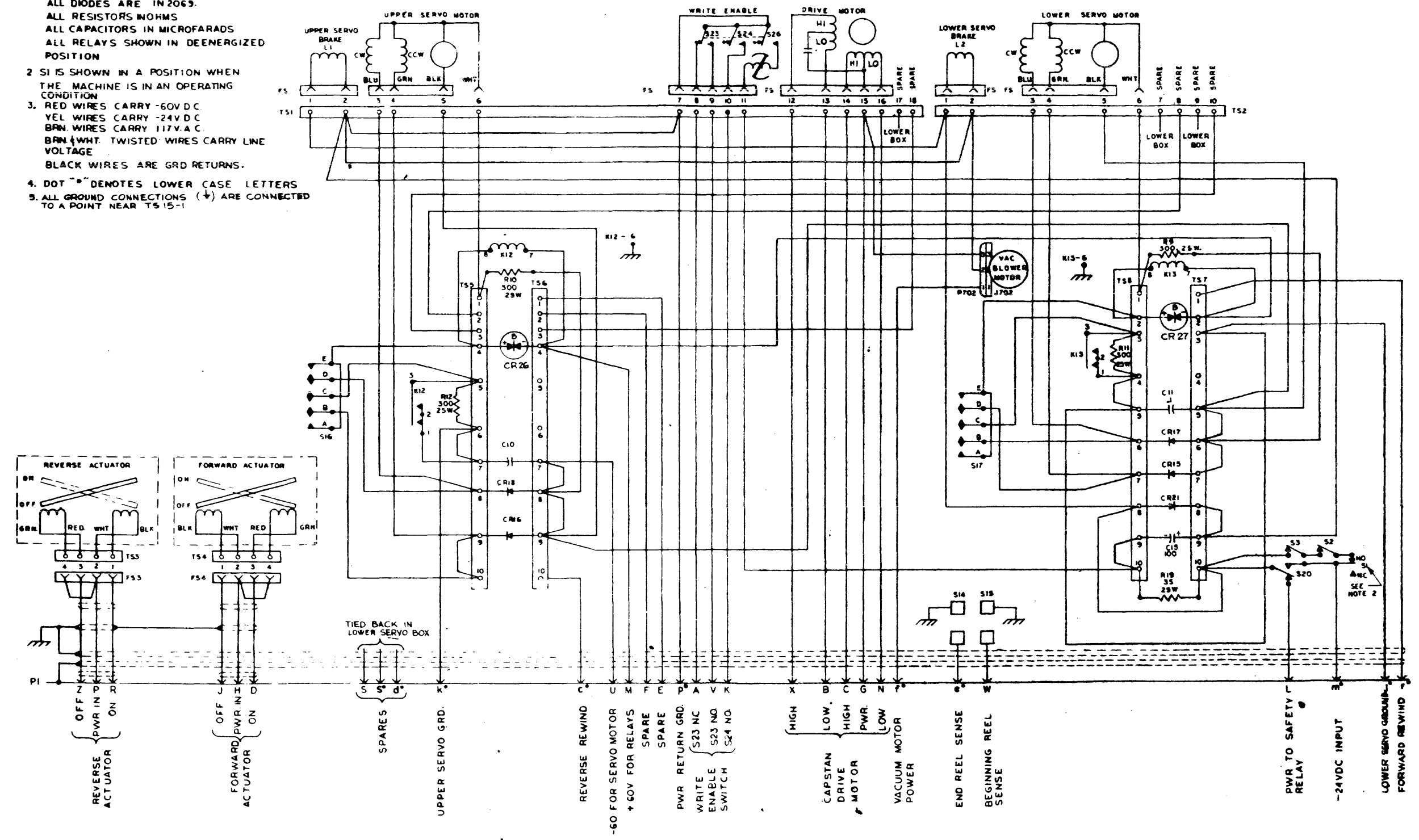

Figure 6-1.
 Tape Transport Assembly, Schematic Diagram
 (31 04438 10C)

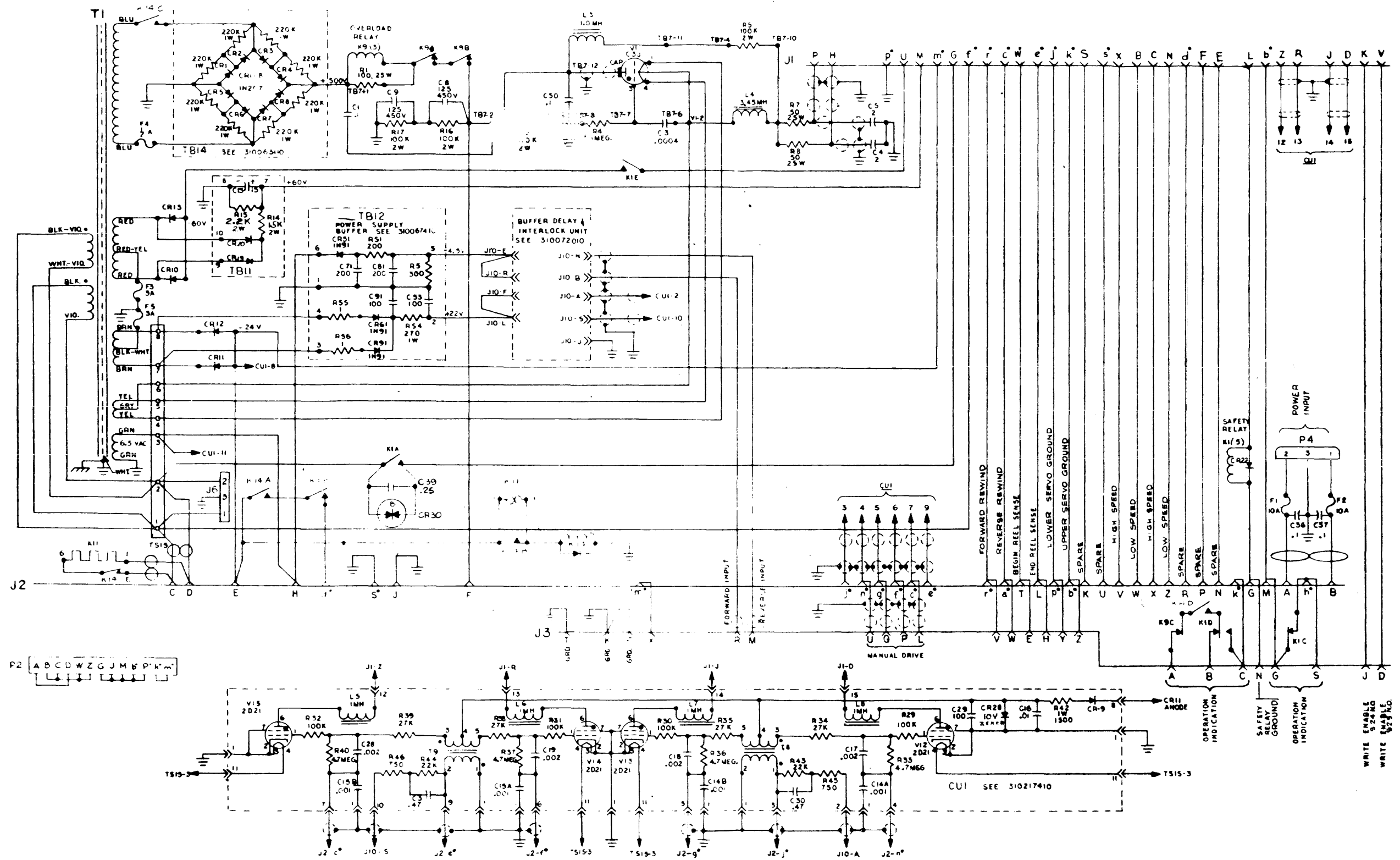
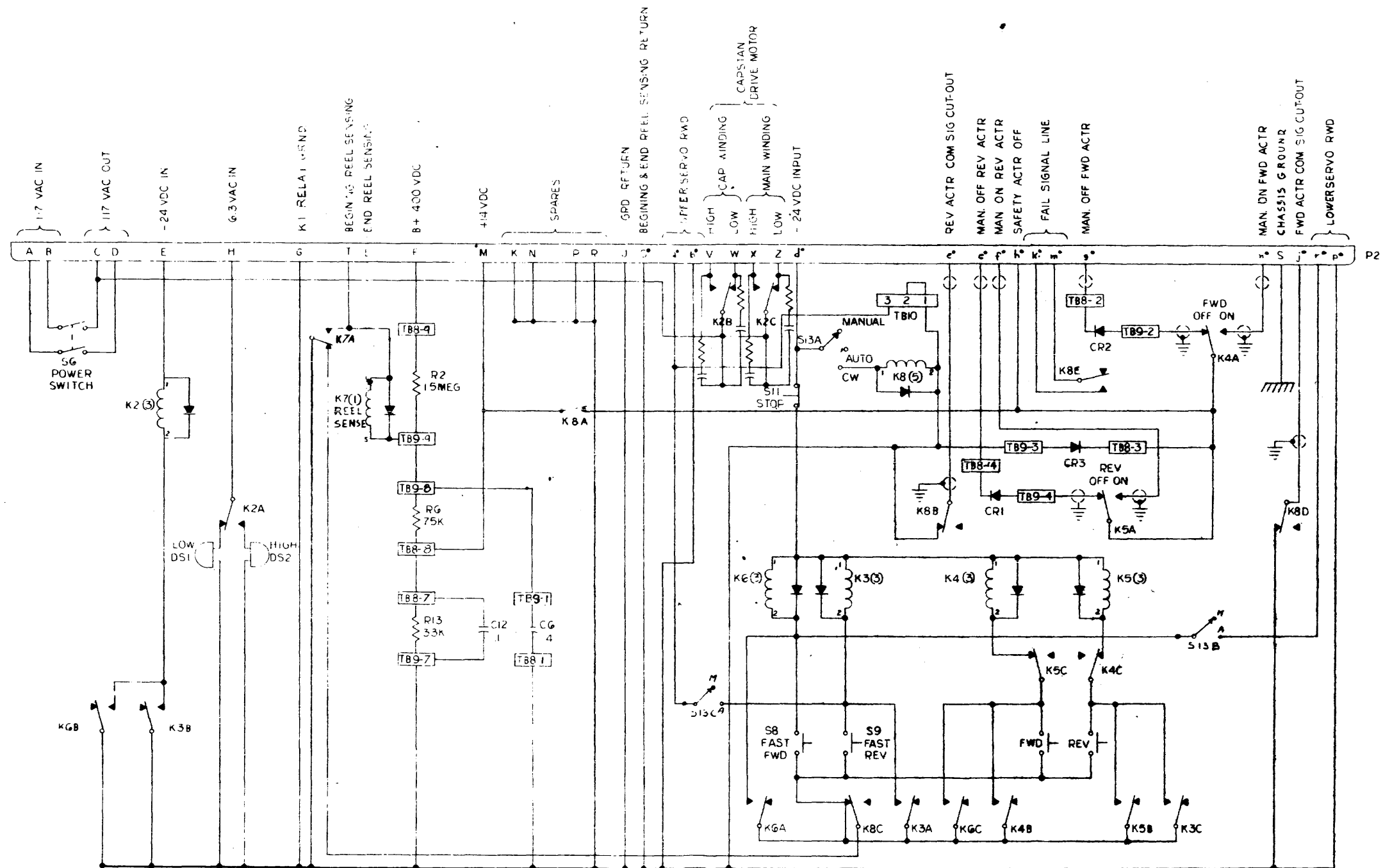

Figure 6-2.
 Transport Electronics Assembly, Schematic Diagram
 (31 04438 10C)



- 7. SIGNIFIES CHASSIS GROUND SIGNIFIES COMMON GROUND
 - 6. USED WITH ASSY NO 310543710
 - 5. S13- D-E NOT USED.
 - 4. ALL DIODES ARE IN2069
 - 3. ALL RELAYS SHOWN IN DEENERGIZED POSITION
 - 2. ALL RESISTORS IN OHMS
 - 1. ALL CAPACITORS IN MICROFARADS
- NOTES: UNLESS OTHERWISE SPECIFIED

Figure 6-4.
 Pushbutton Control Assembly, Schematic Diagram
 (31 05438 10B)