Storage Technology Corporation

**2920
Tape
Subsystem**

Maintenance Manual

PN 95521

Information contained in this publication is subject to change. In the event of changes, the publication will be revised. Comments or questions concerning this manual should be directed to Tape/Disk Technical Publications at the address below. A prepaid Reader's Comment Form is provided at the back of the manual.

This publication was prepared by Storage Technology Corporation, Tape/Disk Technical Publications, MD 97, 2270 South 88th Street, Louisville, Colorado 80028.

Copyright © 1983
by
Storage Technology Corporation
All Rights Reserved

LIST OF EFFECTIVE PAGES

Publication PN 95521

Issue Date: August 1983 EC 49546

Change Date: April 1984 Change 5 EC 49576 Kit PN 97560

Total number of pages in this document is 254, consisting of the following pages:

Page	EC No.	Kit PN	Disposition
Title	EC 49288	None	
Copyright	EC 49288	None	
iii thru iv	EC 49576	97560	Replace
v	EC 49529	94929-7	
vi thru x	EC 49430	94786-1	
xi	EC 49546	94931-3	
xii thru xiv	EC 49430	94786-1	
1-1	EC 49288	None	
1-2 thru 1-3	EC 49497	94925-5	
1-4	EC 49430	94786-1	
1-5 thru 1-6	EC 49497	94925-5	
2-1 thru 2-4	EC 49288	None	
2-5 thru 2-8	EC 49430	94786-1	
2-9 thru 2-14	EC 49529	94929-7	
3-1	EC 49288	None	
3-2 thru 3-7	EC 49430	94786-1	
3-8	EC 49497	94925-5	
3-9	EC 49430	94786-1	
3-10	EC 49497	94925-5	
3-11	EC 49430	94786-1	
3-12 thru 3-14	EC 49497	94925-5	
4-1 thru 4-6	EC 49430	94786-1	
4-7	EC 49497	94925-5	
4-8	EC 49430	94786-1	
4-9	EC 49497	94925-5	
4-10 thru 4-25	EC 49430	94786-1	
4-26	EC 49497	94925-5	
4-27 thru 4-28	EC 49430	94786-1	
4-29 thru 4-30	EC 49497	94925-5	
4-31 thru 4-34	EC 49430	94786-1	
5-1 thru 5-14	EC 49288	None	
5-15	EC 49430	94786-1	
5-16	EC 49288	None	
6-1 thru 6-2	EC 49288	None	
6-3	EC 49546	94931-3	
6-4	EC 49497	94925-5	
6-5 thru 6-6	EC 49430	94786-1	
6-7	EC 49546	94931-3	
6-8 thru 6-10	EC 49430	94786-1	
7-1	EC 49430	94786-1	

LIST OF EFFECTIVE PAGES

Page	EC No.	Kit PN	Disposition
7-2	EC 49497	94925-5	
7-3 thru 7-7	EC 49430	94786-1	
7-8	EC 49497	94925-5	
7-9 thru 7-26	EC 49430	94786-1	
8-1	EC 49430	94786-1	
8-2 thru 8-18	EC 49288	None	
A-1 thru A-82	EC 49576	97560	Replace
B-1 thru B-2	EC 49430	94786-1	
C-1 thru C-8	EC 49288	None	
D-1 thru D-6	EC 49430	94786-1	
I-1 thru I-4	EC 49430	94786-1	
Reader's Comment Form	None	None	Replace
Business Reply Mailer	None	None	Replace

TABLE OF CONTENTS

Paragraph	Title	Page
CHAPTER 1	GENERAL INFORMATION	
1.1	Introduction	1-1
1.2	General Description	1-1
1.3	Specifications	1-5
1.3.1	Physical Dimensions	1-5
1.3.2	Environmental Requirements	1-5
1.3.3	Power Requirements	1-6
CHAPTER 2	OPERATION	
2.1	Introduction	2-1
2.2	Power On/Off Switch	2-1
2.3	Display	2-1
2.4	Operator Functions Area	2-2
2.4.1	Ready Indicator	2-2
2.4.2	Select Indicator	2-2
2.4.3	EOT/BOT Indicator	2-2
2.4.4	On Line Indicator	2-2
2.4.5	Machine Check Indicator	2-2
2.4.6	File Protect Indicator	2-4
2.4.7	System Select/1600/6250 Indicators	2-4
2.4.8	Density Select Key	2-4
2.4.9	Rewind/Unload Key	2-5
2.4.10	Reset Key	2-5
2.4.11	Load/Rewind Key	2-5
2.4.12	On Line Key	2-5
2.5	Diagnostic Keypad	2-5
2.5.1	Enter Address Key	2-6
2.5.2	Display Address Key	2-6
2.5.3	Modify Memory Key	2-7
2.5.4	Enter Probe Key	2-7
2.5.5	Enter Diagnostic Key	2-8
2.5.6	Enter Key	2-8
2.5.7	Clear Key	2-8
2.6	Operating Procedures	2-9
2.6.1	Thread/Load	2-9
2.6.1.1	Semi-Automatic Threading	2-10
2.6.1.2	Manual Threading	2-11
2.6.2	Rewind	2-12
2.6.3	Unload	2-12
2.7	Operator Maintenance	2-12
2.7.1	Read/Write Head and Tape Cleaner Block	2-12
2.7.2	EOT/BOT and Leader Sensors	2-14
2.7.3	Tape Guides, Rollers, and Swing Arms	2-14
2.7.4	Capstan	2-14
2.7.5	File Reel Hub	2-14

TABLE OF CONTENTS (CONT)

Paragraph	Title	Page
CHAPTER 3 INSTALLATION		
3.1	Introduction	3-1
3.2	Inspection	3-1
3.3	Power Connection	3-4
3.4	Preliminary Checkout	3-4
3.5	Cabinet Mounting	3-6
3.5.1	Vertical Mount	3-6
3.5.2	Horizontal Mount	3-10
3.6	Interface Cabling	3-10
3.7	Address Selection	3-10
3.8	Reshipping	3-10
CHAPTER 4 INTERFACE		
4.1	Introduction	4-1
4.2	Definitions	4-1
4.2.1	MTS Address (ADx)	4-1
4.2.2	Initiate Command (START)	4-3
4.2.3	Command Select (CMDx)	4-5
4.2.4	Density Select (DSx)	4-6
4.2.5	Transfer Acknowledge (TRAK)	4-6
4.2.6	Terminate Command (STOP)	4-7
4.2.7	System Reset (RESET)	4-7
4.2.8	Select Multiplex (SLXx)	4-8
4.2.9	Bi-Directional Data (DATA x)	4-8
4.3	Output Signal Definitions	4-9
4.3.1	Transfer Request (TREQ)	4-9
4.3.2	Expecting Data (RECV)	4-9
4.3.3	Block Sensed (BLOCK)	4-9
4.3.4	Oscillator (OSC)	4-9
4.3.5	End of Data Pulse (ENDATP)	4-9
4.3.6	Busy (BUSY)	4-10
4.3.7	Identification Burst (ID BRST)	4-10
4.3.8	Tape Mark Status (TMS)	4-10
4.3.9	Command Reject (REJECT)	4-10
4.3.10	Operation Incomplete (OP INC)	4-11
4.3.11	Overrun Status (OVRNS)	4-11
4.3.12	EPROM Error (ROMPS)	4-11
4.3.13	Slave Status Change (SSC)	4-11
4.3.14	Data Check (DATA CHK)	4-12
4.3.15	Error Multiplex (ERRMX x)	4-12
4.3.15.1	Mux Byte 0	4-13
4.3.15.2	Mux Byte 1	4-13
4.3.15.3	Mux Byte 2	4-15
4.3.15.4	Mux Byte 3	4-15

TABLE OF CONTENTS (CONT)

Paragraph	Title	Page
4.3.16	Corrected Error (CRERR)	4-18
4.3.17	Data Bus Parity Error (BUPER)	4-18
4.3.18	Online Status (ONLS)	4-18
4.3.19	Ready Status (RDYS)	4-18
4.3.20	Beginning of Tape Status (BOTS)	4-18
4.3.21	End of Tape Status (EOTS)	4-19
4.3.22	File Protect Status (FPTS)	4-19
4.3.23	Write Status (WRTS)	4-19
4.3.24	High Density Status (HDNS)	4-19
4.3.25	Rewinding Status (REWS)	4-19
4.4	Functional Mode Command Descriptions	4-20
4.4.1	General	4-20
4.4.1.1	Command Initiation	4-20
4.4.1.2	Reject Conditions	4-21
4.4.1.3	Operation Completed	4-21
4.4.1.4	Ending Status Validity	4-21
4.4.1.5	End of Tape Status (EOTS)	4-21
4.4.1.6	Commands with MTS in Write Status	4-21
4.4.1.7	Improper Command Sequences	4-22
4.4.2	No Operation (NOP) Command	4-22
4.4.3	Drive Clear (CLR) Command	4-22
4.4.4	Diagnostic Mode Set (DMS) Command	4-22
4.4.5	Read Forward a Block (RDF) Command	4-23
4.4.6	Read Backward a Block (RDB) Command	4-25
4.4.7	Write a Data Block (WRT) Command	4-26
4.4.8	Loop Write-to-Read (LWR) Command	4-28
4.4.9	Backspace a File (BSF) Command	4-29
4.4.10	Backspace a Block (BSB) Command	4-30
4.4.11	Forward Space a File (FSF) Command	4-31
4.4.12	Forward Space A Block (FSB) Command	4-31
4.4.13	Write Tape Mark (WTM) Command	4-32
4.4.14	Erase Gap (ERG) Command	4-33
4.4.15	Rewind (REW) Command	4-33
4.4.16	Rewind and Unload (RUN) Command	4-34
4.4.17	Sense Drive Status (SNS) Command	4-34
CHAPTER 5	FUNCTIONAL DESCRIPTION	
5.1	Introduction	5-1
5.2	Interface/Microprocessor (IF Card)	5-1
5.3	Write Data Path (DP Card)	5-1
5.4	Write Drivers (WR Card)	5-5
5.5	Read (RD Card)	5-7
5.6	Read Data Path (DP Card)	5-9
5.6.1	PE Operation	5-9
5.6.2	GCR Operation	5-11
5.7	Servo System (SV Card)	5-12
5.8	Power System	5-15

TABLE OF CONTENTS (CONT)

Paragraph	Title	Page
CHAPTER 6	MAINTENANCE	
6.1	Introduction	6-1
6.2	Preventive Maintenance	6-1
6.3	Power Supply Check	6-2
6.4	Tape Tracking and Skew	6-2
6.4.1	Capstan Alignment (Tape Tracking)	6-3
6.4.2	Skew Adjustment	6-5
6.4.3	Bit Position Check	6-8
6.5	Read Amplitude Checks	6-9
CHAPTER 7	REMOVAL AND REPLACEMENT	
7.1	Introduction	7-1
7.1.1	Fuses	7-1
7.1.2	Torx Screws	7-3
7.2	Tape Path	7-3
7.2.1	EOT/BOT Sensor Replacement	7-3
7.2.2	Leader Sensor Replacement	7-4
7.2.3	Tape Cleaner Block Replacement	7-4
7.2.4	File Protect Sensor Replacement	7-5
7.2.5	Read/Write Head Replacement	7-5
7.3	Swing Arms	7-7
7.3.1	Lower Swing Arm Assembly Replacement	7-7
7.3.2	Lower Swing Arm Tach Assembly Replacement	7-10
7.3.3	Upper Swing Arm Assembly Replacement	7-11
7.3.4	Upper Swing Arm Tach Assembly Replacement	7-13
7.3.5	Retractor Motor Replacement	7-14
7.4	Capstan, Reels, and Blower	7-17
7.4.1	Capstan Motor Replacement	7-17
7.4.2	File Reel Hub Replacement	7-18
7.4.3	File Reel Motor Replacement	7-19
7.4.4	Machine Reel Motor Replacement	7-20
7.4.5	Vacuum Blower Replacement	7-21
7.5	Circuit Cards	7-21
7.5.1	Card Cage Circuit Cards Replacement	7-21
7.5.2	Front Operator Panel Replacement	7-22
7.5.3	AK Card Replacement	7-22
7.5.4	PK Card Replacement	7-23
7.5.5	Motherboard Replacement	7-23
7.6	Power Supply and Fans	7-24
7.6.1	Rectifier Assembly Replacement	7-24
7.6.2	Transformer Replacement	7-24
7.6.3	Main Circuit Breaker Replacement	7-25
7.6.4	Cooling Fan Replacement	7-25

TABLE OF CONTENTS (CONT)

Paragraph	Title	Page
CHAPTER 8 DIAGNOSTIC/MAINTENANCE PROGRAMS		
8.1	Introduction	8-1
8.1.1	Test Initiation	8-1
8.1.2	Status Buffers	8-2
8.2	Section 0 - Maintenance Routines	8-2
8.2.1	Forward Motion (00)	8-3
8.2.2	Backward Motion (01)	8-3
8.2.3	Shoeshine Motion (02)	8-3
8.2.4	Start/Stop Motion (03)	8-4
8.2.5	Continue Option (05)	8-4
8.2.6	Loop Option (06)	8-4
8.2.7	Bypass Error Option (07)	8-5
8.2.8	Keyboard/LED Driver (08)	8-5
8.2.9	Reel/Capstan Driver (09)	8-5
8.2.10	Status A Display (0A)	8-6
8.2.11	Status B Display (0B)	8-6
8.2.12	Status C Display (0C)	8-6
8.2.13	Maintenance Write (0E)	8-6
8.2.14	Maintenance Write (0F)	8-7
8.3	Internal Diagnostics	8-7
8.3.1	Section 1 - Power-Up Tests	8-7
8.3.1.1	Test Package Initiator (10)	8-7
8.3.1.2	Memory/PROM Checksum (12)	8-7
8.3.1.3	Counters (13)	8-9
8.3.1.4	Interrupt Controller (14)	8-9
8.3.1.5	Keyboard Status (15)	8-9
8.3.1.6	Servo-LSI Register Loop (18)	8-9
8.3.1.7	Data Path Status (1B)	8-10
8.3.1.8	Write Card Status (1D)	8-10
8.3.1.9	Release/Retract Swing Arms (1F)	8-10
8.3.2	Section 2 - Formatter Tests	8-10
8.3.2.1	PE Basic Loop Write-to-Read (22)	8-11
8.3.2.2	PE LWR Velocity (23)	8-11
8.3.2.3	GCR Basic Loop Write-to-Read (24)	8-11
8.3.2.4	GCR LWR Velocity (25)	8-12
8.3.2.5	PE LWR, One Track Dead (26)	8-12
8.3.2.6	GCR LWR, One Track Dead (27)	8-13
8.3.2.7	PE LWR, Two Tracks Dead (28)	8-13
8.3.3	Section 3 - Transport Tests	8-13
8.3.3.1	Unload/Load (32)	8-14
8.3.3.2	Drive Basic Motion (34)	8-14
8.3.3.3	Drive Rewind (36)	8-15
8.3.4	Section 4 - Read/Write Tests	8-15
8.3.4.1	PE Amplitude Sensor (42)	8-15
8.3.4.2	GCR Amplitude Sensor (43)	8-15

TABLE OF CONTENTS (CONT)

Paragraph	Title	Page
8.3.4.3	PE Write Records (48)	8-15
8.3.4.4	PE Read Forward (49)	8-16
8.3.4.5	PE Read Backward (4A)	8-16
8.3.4.6	PE Positioning (4B)	8-16
8.3.4.7	GCR Write Records (4C)	8-16
8.3.4.8	GCR Read Forward (4D)	8-17
8.3.4.9	GCR Read Backward (4E)	8-17
8.3.4.10	GCR Positioning (4F)	8-17
8.4	External Diagnostics	8-17
APPENDIX A	FAULT CODE DICTIONARY	
APPENDIX B	SPECIAL TEST EQUIPMENT, TOOLS, AND SUPPLIES	
APPENDIX C	DATA FORMATS	
APPENDIX D	MEMORY ALLOCATION	
INDEX		

LIST OF ILLUSTRATIONS

Figure	Title	Page
1-1	Model 2920 MTS	1-2
1-2	Model 2920 MTS (Rear View)	1-3
1-3	Card Cage (Front View)	1-4
2-1	Operator Panel	2-3
2-2	Tape Thread Path	2-11
2-3	Tape Path Components	2-13
3-1	Internal Cabling	3-3
3-2	MTS Installation	3-7
3-3	Mounting Dimensions	3-8
3-4	Suggested Lifting Methods	3-9
3-5	IF Card	3-11
3-6	MTS Interface Cabling	3-12
3-7	MTS Interface Cables	3-14
4-1	MTS-User Interface Circuits	4-2
4-2	Command Initiation, Operation, and Completion	4-20
4-3	RDF or RDB Command TREQ, TRAK, and DATA Timing	4-24
4-4	Write Commands Initiating TREQ/TRAK/DATA	4-27
4-5	WRT Command TREQ, TRAK and DATA	4-27
5-1	MTS Block Diagram	5-2
5-2	Interface/Microprocessor Block Diagram (IF Card)	5-3
5-3	Write Path Block Diagram (DP Card)	5-4
5-4	Write Driver Block Diagram (WR Card)	5-6
5-5	Read Block Diagram (RD Card)	5-8
5-6	Read Path Block Diagram (DP Card)	5-10
5-7	Capstan Servo System Block Diagram	5-13
5-8	Reel Servo System Block Diagram	5-14
5-9	Power System Block Diagram	5-16
6-1	Static and Dynamic Skew and Turnaround Jump	6-3
6-2	Capstan and Read/Write Head Alignment	6-4
6-3	+Dif Analog Test Points	6-6
6-4	Bit Position Check	6-8
7-1	2920 MTS Deck (Front)	7-2
7-2	Read/Write Head	7-6
7-3	Swing Arm Assemblies	7-8
7-4	Retractor Assembly	7-15
C-1	PE Tape Format	C-2
C-2	GCR Tape Format	C-4
C-3	GCR Data Block Format	C-5

(INTENTIONALLY LEFT BLANK)

LIST OF TABLES

Table	Title	Page
1-1	Performance Specifications	1-4
4-1	Input Lines	4-3
4-2	Output Lines	4-4
4-3	MTU Address Line Decode	4-5
4-4	Command Select Decode	4-5
4-5	Density Select Line Decode	4-6
4-6	Select Multiplex Decode	4-8
4-7	Error Conditions Setting DATA CHK	4-12
4-8	Error Multiplex Bus Decode for Functional Mode	4-13
4-9	Status Lines Asserted with WTM CHK	4-14
4-10	Reject Codes	4-16
6-1	Capstan Alignment	6-4
8-1	Maintenance Routines	8-2
8-2	Internal Diagnostics	8-8

(INTENTIONALLY LEFT BLANK)

CHAPTER 1

GENERAL INFORMATION

1.1 INTRODUCTION

This chapter is an introduction to the Storage Technology Corporation Model 2920 Magnetic Tape System (MTS). This chapter includes a general description of the physical and functional layout of the MTS and includes the MTS specifications.

1.2 GENERAL DESCRIPTION

The Model 2920 MTS (Figures 1-1 and 1-2) is an integrated tape formatter/controller and half-inch tape drive packaged as a single self-contained unit (1x1). The MTS is a dual-density device capable of recording and reading ANSI compatible tapes in phase-encoded (PE) format at 1600 bits per inch (bpi) and group-coded recording (GCR) format at 6250 bpi at a tape speed of 50 inches per second (ips).

The MTS is a low-cost, medium performance device intended for use in traditional tape processing and/or disk off-loading. The device features automatic tape threading/loading of open reel sizes 7, 8.5, and 10.5 inches; tension arm tape buffering; microprocessor capstan servo and microprocessor reel servo; and on-board diagnostics for functional verification and fault detection.

Data can be read when tape is moving either forward or backward but recording can be performed during forward tape motion only. Performance specifications are shown in Table 1-1.

The electronics of the MTS are located on five plug-in printed circuit cards located in a card cage below the operator panel. These cards are identified in Figure 1-3. In addition, there is an operator panel circuit card (KK) and three power supply circuit cards: the AK and NK regulator cards and the PK protect card.

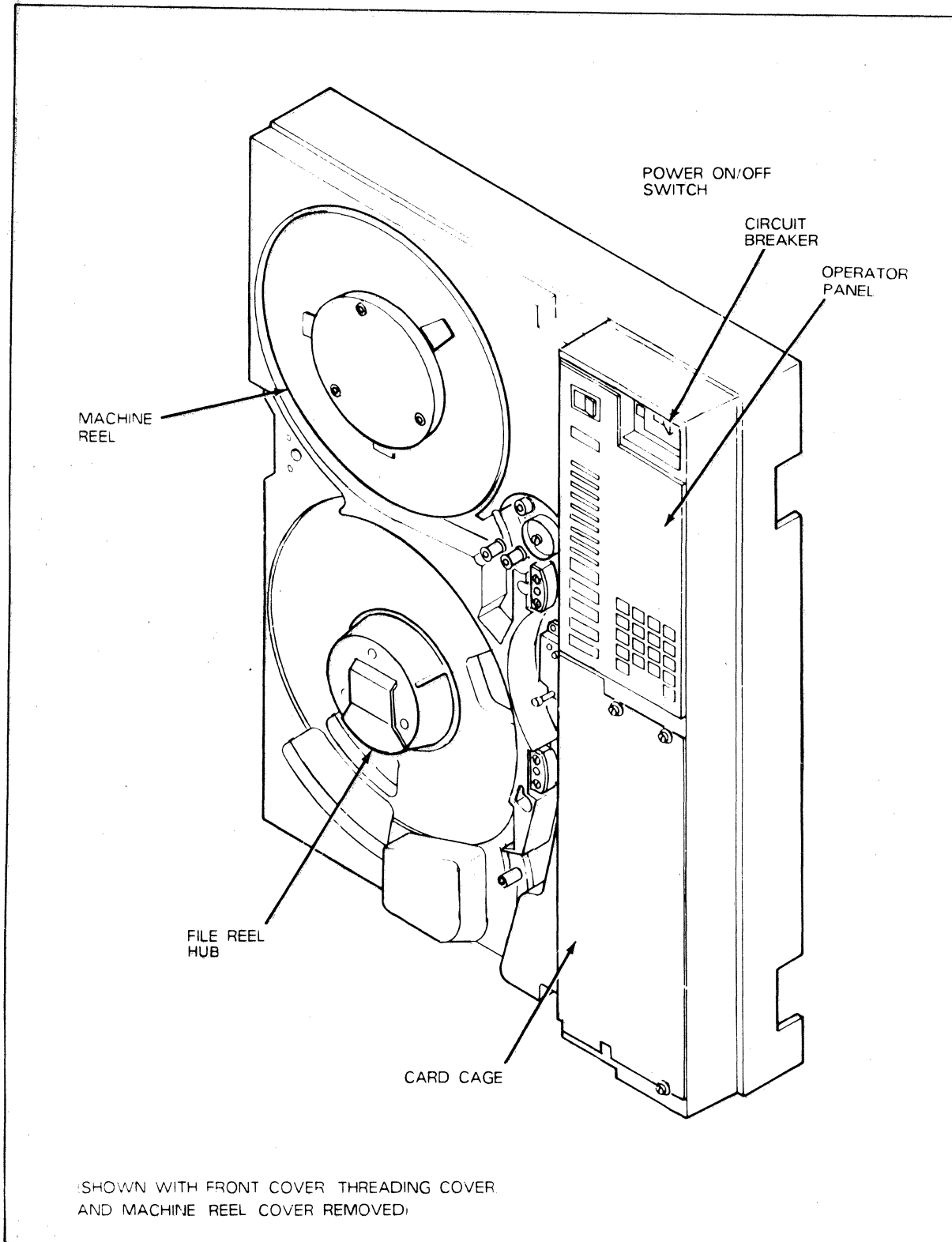

Figure 1-1. Model 2920 MTS

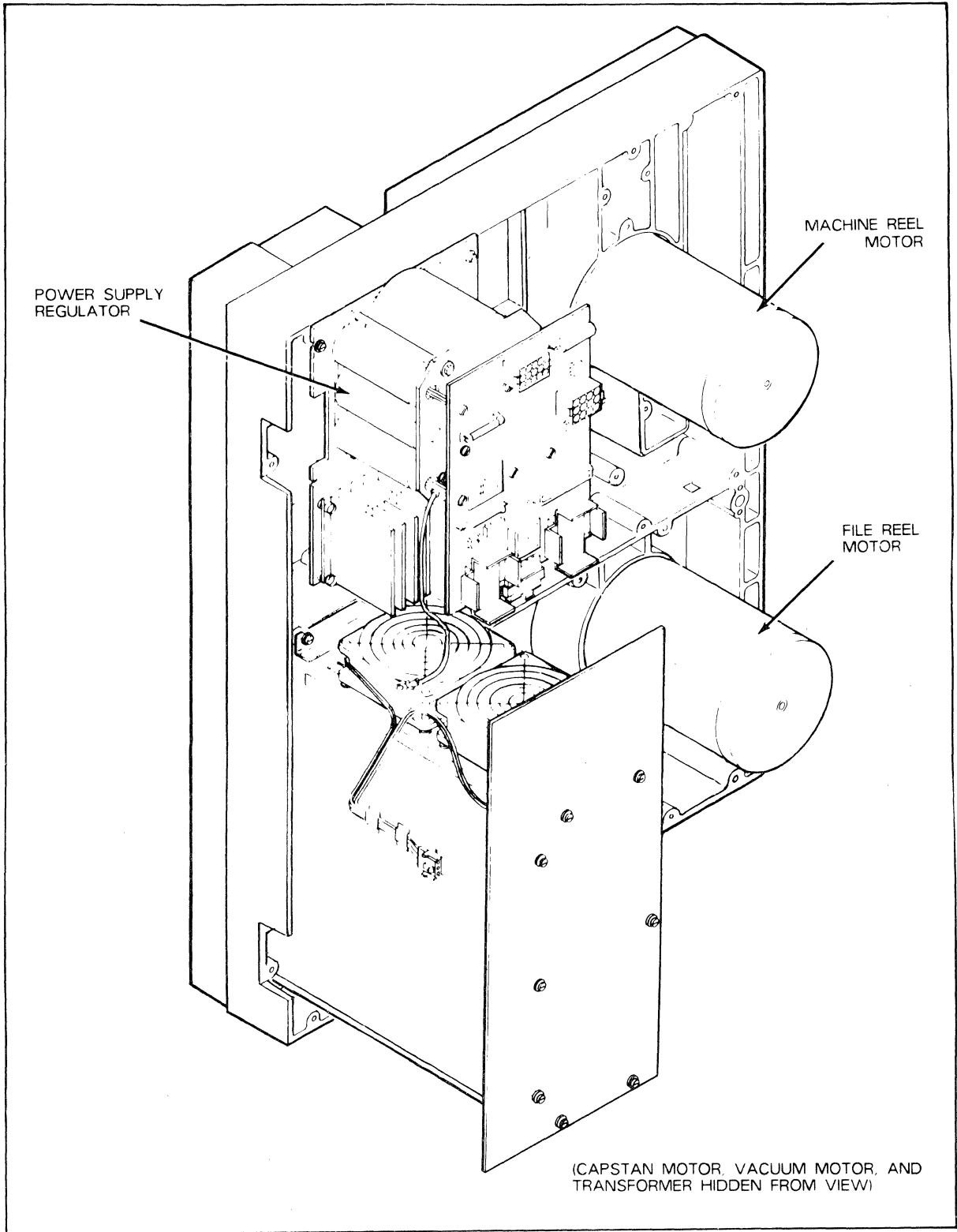
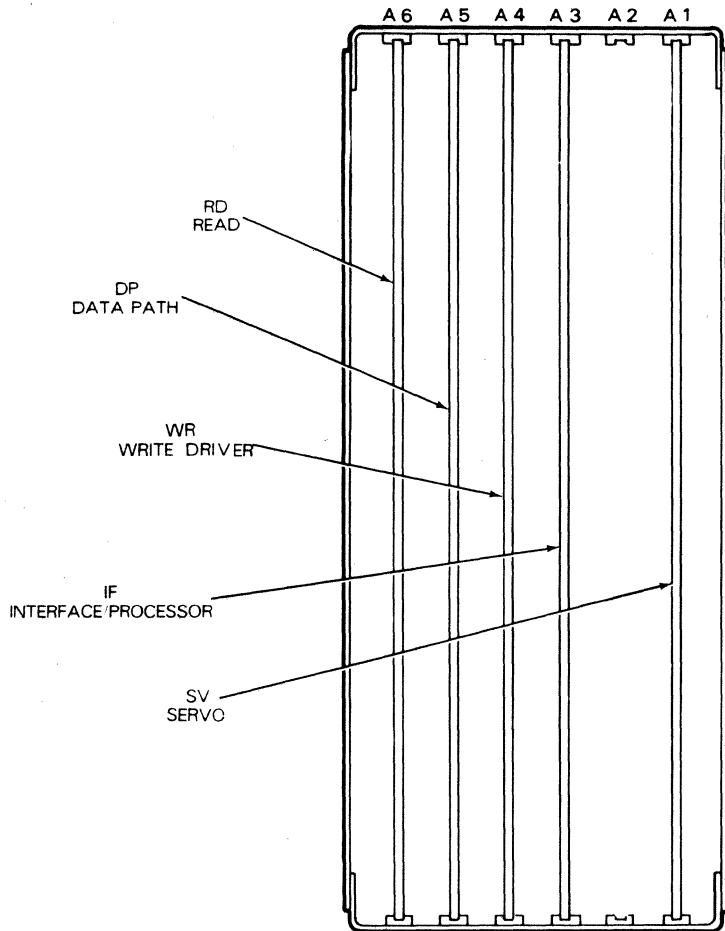

Figure 1-2. Model 2920 MTS (Rear View)



12015

Figure 1-3. Card Cage (Front View)

Table 1-1. Performance Specifications

Tape Speed	50 ips
Data Density GCR PE	6250 bpi 1600 bpi
Data Transfer Rate GCR PE	313 kB/s 80 kB/s
Access Time (nominal)	5.0 ms
Write Interblock Gap (nominal) GCR PE	0.45 inch 0.60 inch
Rewind Time (nominal) (2400-foot reel)	2.5 minutes

1.3 SPECIFICATIONS

1.3.1 PHYSICAL DIMENSIONS

The nominal outside dimensions of the MTS are:

Height	24.5 inches (62.2 cm)
Width	19.0 inches (48.3 cm)
Depth	16.0 inches (40.6 cm)
Projection	4.8 inches (12.2 cm) from RETMA mounting surface
Weight	125 pounds (57 kg)

1.3.2 ENVIRONMENTAL REQUIREMENTS

Temperature (Ambient Room Air):

Optimum	+16°C to +22°C (+60°F to +72°F)
Operating	+16°C to +31°C (+60°F to +90°F)
Non-Operating	-40°C to +70°C (-40°F to +158°F)

Relative Humidity:

Optimum	37% to 42%, noncondensing
Operating	20% to 80%, noncondensing
Storage	10% to 90%, noncondensing
Shipping	Any, noncondensing

The storage environment must not exist outside the limits of the operating environment for a period longer than six months.

The MTS must not be subjected to a temperature change greater than 8°C (15°F) per hour.

Altitude

Operating	Up to 1830 meters (6,000 feet) standard Up to 3050 meters (10,000 feet) with manual-assisted thread
Non-Operating	Up to 15 240 meters (50,000 feet)

1.3.3 POWER REQUIREMENTS

The MTS is designed to operate on any one of the following single-phase power sources:

Nominal Voltage	Voltage Range	Frequency	Maximum Current
100 Vac 120 Vac	85-110 102-132	60 (±1) Hz 60 (±1) Hz	4 amps 4 amps
200 Vac 220 Vac 240 Vac	170-220 187-242 204-264	50 (±1) Hz 50 (±1) Hz 50 (±1) Hz	2 amps 2 amps 2 amps

The MTS is assembled and shipped to operate from either a 120 Vac, 60 Hz power source or a 220 Vac, 50 Hz power source. Conversion to other power sources requires changes to the primary side wiring of the MTS input power transformer (refer to Section 3.3).

CHAPTER 2

OPERATION

2.1 INTRODUCTION

This chapter describes the operator panel functions and status indicators, the common MTS operating procedures, and the required operator maintenance.

2.2 POWER ON/OFF SWITCH

The Power On/Off switch is used to power up or power down the MTS. When powered up, the MTS initializes and invokes a series of power-up diagnostics.

2.3 DISPLAY

The operator panel contains a four-character display. When the MTS is in Online Status, the display is blank. During machine check conditions, the display contains a three-digit fault code. When the MTS is offline and at idle, the display contains four dashes indicating that the MTS is ready to accept diagnostic commands. When a key is depressed, all segments of the display are lit to indicate that the key has been recognized and accepted. When pressure is removed from the key, the display returns to its previous state.

Throughout this manual, display conditions are shown enclosed within parentheses. To summarize the display conditions and their meanings:

()	Online
(----)	Offline, panel idle, test successfully completed
(@n)	Executing test
(@nn)	Executing test
(nn)	Displaying data (flashing if from probe)
(nnnn)	Displaying address
(??)	Request for data or test ID input
(????)	Request for address input
(nnn)	Fault code (refer to Appendix A)

2.4 OPERATOR FUNCTIONS AREA

The operator functions area of the operator panel (Figure 2-1) provides status indicators and a keypad for operator control of the normal functions of the MTS.

2.4.1 READY INDICATOR (GREEN)

The Ready indicator is illuminated when the MTS is fully loaded and not performing a rewind operation. The indicator is active whether or not the MTS is in Online Status.

2.4.2 SELECT INDICATOR (YELLOW)

The Select indicator is illuminated when the MTS is in Online Status and has been selected for use by the USER (that is, the MTS Address lines match the address of the MTS).

2.4.3 EOT/BOT INDICATOR (GREEN)

The EOT/BOT indicator is illuminated when EOT or BOT Status is set in the MTS; that is, when the BOT marker is adjacent to the BOT sensor or when the EOT marker is adjacent to or past the EOT sensor. When the indicator is lit at EOT, it remains illuminated until a rewind or backward read operation moves the EOT marker back past the EOT sensor.

2.4.4 ON LINE INDICATOR (GREEN)

The On Line indicator is illuminated when Online Status is set in the MTS; that is, when the MTS is available to the USER.

2.4.5 MACHINE CHECK INDICATOR (RED)

The Machine Check (MACH CHK) indicator flashes to signal either a load check, which may be operator correctable, or to signal a malfunction of the MTS that requires service. A fault code of three characters will be posted in the display.

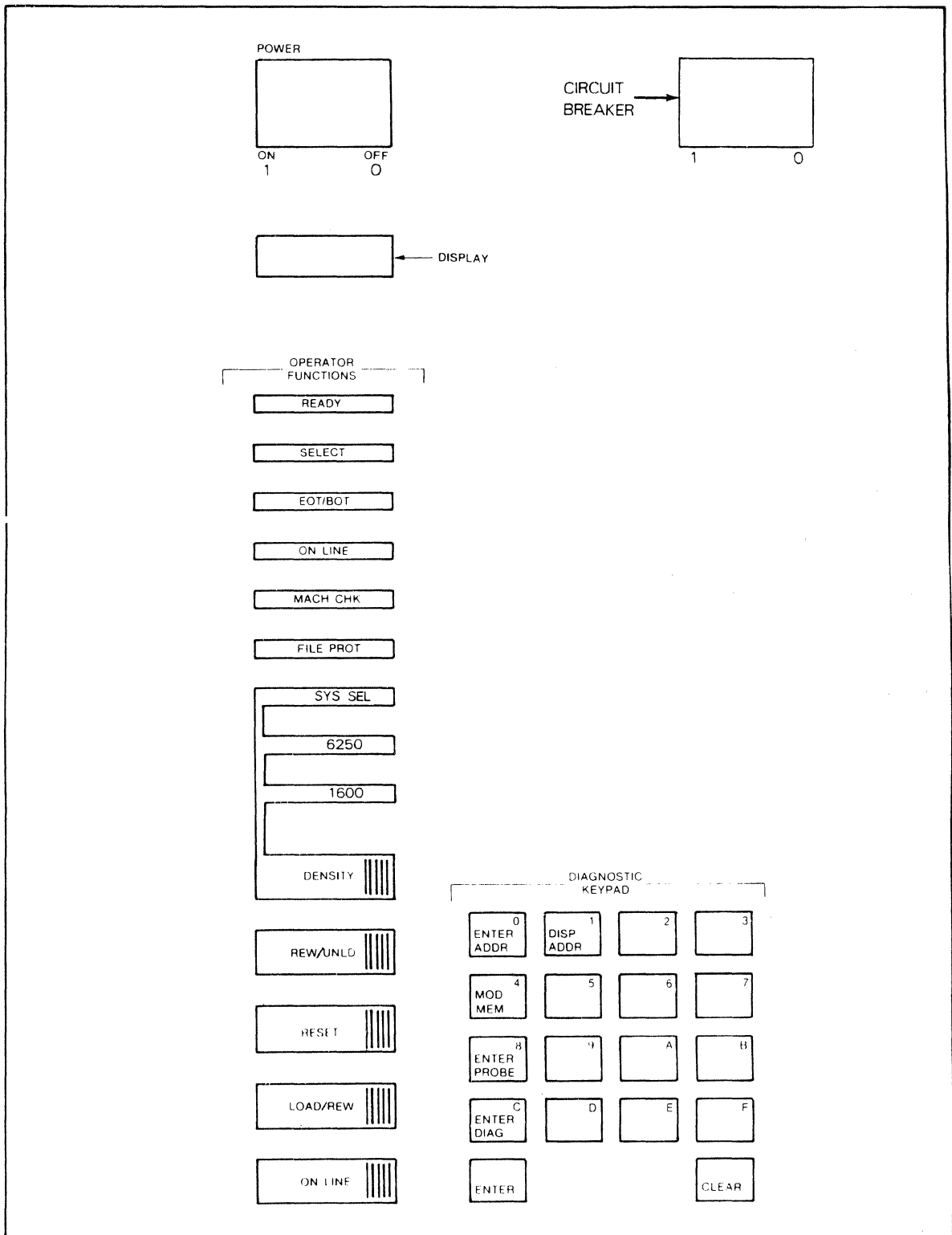

Figure 2-1. Operator Panel

2.4.6 FILE PROTECT INDICATOR (RED)

The File Protect (FILE PROT) indicator is illuminated when tape is loaded and a write enable ring is not in place on the file reel. No write operations are allowed if this indicator is illuminated.

2.4.7 SYSTEM SELECT/1600/6250 INDICATORS (YELLOW)

The System Select (SYS SEL), 1600, and 6250 indicators are used to show the current operating density of the MTS. The operator may select a density mode using the Density Select key when the MTS is either not loaded or loaded and positioned at BOT. The selected mode determines the density in which a tape is to be written.

Illumination of the 1600 indicator alone indicates that the tape will be written in 1600 bpi density (PE format). Illumination of the 6250 indicator alone indicates that the tape will be written in 6250 bpi density (GCR format). Illumination of the System Select indicator in combination with illumination of the 1600 indicator indicates that the recording density is to be selected by the CPU. On power up, the MTS will indicate System Select and 1600.

A read operation will be in the correct density regardless of the initial setting of the indicators. When the density of the tape being read has been determined, the corresponding indicator (1600 or 6250) is illuminated.

2.4.8 DENSITY SELECT KEY

The Density Select (DENSITY) key is used to select a recording density when the drive is unloaded or tape is loaded and at BOT. Successive actuations of the key causes the MTS to cycle through the possible density modes. Initially the MTS will be set to SYS SEL/1600 mode. Pressing DENSITY causes the MTS to go to 1600 bpi density. A second press causes the MTS to go to 6250 bpi density. Entering DENSITY a third time returns the MTS to SYS SEL/1600 mode.

Execution of a diagnostic routine may cause the density status of the MTS to change. A tape load operation will reinitialize the MTS to SYS SEL/1600 mode.

2.4.9 REWIND/UNLOAD KEY

The Rewind/Unload (REW/UNLD) key is used to unload tape. If tape is not at BOT when the key is pressed, a high speed rewind to BOT is initiated, the swing arms are retracted, and tape is unloaded from the tape path. Select and Ready Status are reset by this key. This key is not accepted if the MTS is in Online Status.

2.4.10 RESET KEY

The Reset key is used to generate a subsystem reset. Pressing this key resets Select, puts the MTS in Offline Status, terminates any operation and tape motion that is in progress, clears any machine check condition, and returns the display to idle (----).

2.4.11 LOAD/REWIND KEY

The Load/Rewind (LOAD/REW) key serves a dual purpose. If tape is not loaded, this key is used to load tape and position tape at BOT. If tape is loaded, this key causes tape to be rewound and positioned at BOT. This key will not be accepted if the MTS is in Online Status.

2.4.12 ON LINE KEY

The On Line key is used to set the MTS to Online Status; that is, to enable the MTS for use by the USER. (The Reset key is used to reset Online Status.) If the MTS is not already in Online Status, this key will cause all diagnostic functions, including tape motion, to stop. Online Status disables the Rewind/Unload and Load/Rewind keys.

2.5 DIAGNOSTIC KEYPAD

Commands entered on the diagnostic keypad (Figure 2-1) allow access to various functions including maintenance programs execution, internal diagnostics execution, memory examination and modification, and a continuous readout of a memory space location (probe). The operations available are dependent upon the status of the MTS and the current display contents. The keypad will not respond when the MTS is in Online Status or if a machine check

is present (nnn). While idle (----) or error (nnn) is present, all panel functions are available. During the execution of a maintenance program or diagnostic routine (@n) or (@nn), only memory read functions are available (Enter Address, Enter Probe, and Display Address). The Reset key, however, will always be responded to and serves to return the panel to an idle condition (----).

The control functions appear on the keypad as the central heading on a given key. Not all keys have alternate control functions. The protocol for using the diagnostic keypad consists of entering a control function and then entering data characters as required. The display contains input and output symbols appropriate to the function in process.

The diagnostic keypad is also used to enter data characters. The data character associated with a given key appears in its upper right corner.

2.5.1 ENTER ADDRESS KEY

Pressing the Enter Address <ENTER ADDR> key allows the entry of a hexadecimal number representing a location within the memory of the MTS controller. The display prompts for the entry with four question marks (????) until the first entry is made. The first entry then appears right-justified in the display with subsequent entries producing a shift left on the display. Any number of entries may be made. If the target address desired is the same as that most recently referenced, a press of the Enter key directly following the prompt display is sufficient.

When the desired address appears on the display, the Enter key terminates address entry and causes the byte at that address to be displayed as two hex digits, right-justified. At this time each actuation of the Enter key displays the contents of the next memory location.

2.5.2 DISPLAY ADDRESS KEY

When using the Enter key to display a long series of memory locations, it may be necessary to determine the location currently being displayed. Pressing the Display Address <DISP ADDR> key causes the current address to be displayed as four hexadecimal digits. Press the Enter key to display the contents of this address as in a normal enter address sequence.

The address last displayed is stored so that normal machine operation will not destroy it. The Display Address key may then be used at any time (e.g., following a diagnostic routine) and then the Enter key is pressed to recall an often-needed memory location.

If the Display Address key is pressed following subsystem power up and before the Enter Address function is used, memory location 0000 is displayed.

2.5.3 MODIFY MEMORY KEY

The Modify Memory <MOD MEM> key is used to modify a writeable memory location within the MTS controller. This key is recognized only while data from the target location (from an <ENTER ADDR> or <DISP ADDR> key sequence) is being displayed. No memory modification is allowed while a diagnostic routine is executing. 2.5.1. If this key is pressed at any other time, there will be no response.

```
////////////////////  
//// CAUTION ////  
////////////////////
```

If the memory is modified, MTS operation is not guaranteed.

Following the actuation of the Modify Memory key, the display prompts for a byte value input (two hexadecimal entries) by displaying two question marks (??). The operator may now use as many keystrokes as necessary to produce the required data in the display. Each entry results in a shift left of the two digits on the right (the two digits on the left remain blank).

When the data desired to be written is being displayed, pressing the Enter key causes the data to be stored in the current memory location. (If the location being written is a read-only address, there will be no effect on that location.)

2.5.4 ENTER PROBE KEY

The Enter Probe <ENTER PROBE> key is used to cause a constantly updated display of a particular controller memory space location. The updating is indicated by a rapidly flashing byte on the display.

Following the actuation of the Enter Probe key, the display prompts for address input by displaying four question marks (????). Input of the address is as described in Section 2.5.1. Following the delimiting Enter key actuation, the contents of that address is displayed in the two digits on the right. The display flashes the byte continuously at about ten times per second. The system may be brought back to idle by using either the Clear or Reset key.

2.5.5 ENTER DIAGNOSTIC KEY

The Enter Diagnostic <ENTER DIAG> key is used to initiate the entry of subsystem self-contained diagnostic routine numbers. After pressing the Enter Diagnostic key, the display prompts for the entry of a two-digit hexadecimal routine identification by displaying two question marks (??). The operator may now use as many keystrokes as necessary to produce the required ID in the display. Each entry results in a shift left of the two digits on the right (the two digits on the left remain blank).

When the desired routine number appears in the display, pressing the Enter key results in the attempted execution of that routine. The ID is displayed while the routine is being executed; fault codes are displayed as three hexadecimal digits; and completion is indicated by the idle display (----).

A routine in progress may be terminated by pressing the Reset key.

2.5.6 ENTER KEY

The Enter <ENTER> key is specific in nature and is described in the sections above for all sequences. For most cases this key serves to delimit address and data entries and initiates the performance of a requested function.

2.5.7 CLEAR KEY

The Clear <CLEAR> key is used to clear the last data and/or address entry in the display and return to the prompt mode (question marks in the display) of the last function attempted. If the MTS is currently in a prompt mode (no entry has been made), the MTS returns to an idle state and awaits a function request. If a diagnostic routine is being executed, its ID is again displayed.

2.6 OPERATING PROCEDURES

The operator functions keypad of the operator panel is used to accomplish the desired MTS operations. The common operating procedures are described below.

2.6.1 THREAD/LOAD

1. Power up the MTS, if necessary; the swing arms automatically extend and then retract.
2. Place the reel of tape on the file reel hub, then latch the file hub locking lever. Make certain that the reel is secure. Close both the machine reel cover and thread cover.
3. Press LOAD/REWIND. The vacuum blower motor turns on, the sensors are enabled, and power for the reel motors is turned on.

The MTS initially assumes that the tape leader is positioned at the entrance of the tape threading path and rotates clockwise to slip the tape leader into the path. If tape is not sensed at the EOT/BOT sensor within a given amount of time, the file reel reverses and attempts to position the tape leader using the leader sensor. If the leader cannot be sensed, it is assumed that the leader is stuck to the tape reel with static and the file reel is rotated rapidly to try to break the static. When the leader is sensed, it is positioned at the entrance of the tape threading path.

Vacuum created by the blower motor pulls the tape up the tape threading path. The tape is sensed at the EOT/BOT sensor as Tape Present. When the tape has wrapped the machine reel hub, it is sensed as Tape Attached and the blower motor turns off. If any of these steps fails to occur in the prescribed time, a mark is counted against the load. If three marks are counted, the load has been unsuccessful and a fault code is posted in the display.

When Tape Attached is sensed, the tape is moved forward until the beginning-of-tape (BOT) marker is found. Tape continues to move forward a few feet and stops. The swing arms are lowered into their normal operating area.

Tape is rewound to BOT. When BOT is sensed and tape is stopped, the file reel is moved such that the MTS logic can determine file reel size. Tape then moves forward past BOT and a series of start/stop operations is run forward and then repeated backward. These start/stops allow the adaptive features of the capstan control algorithms to initialize for the current tape.

Tape is then brought back to BOT and stopped. The Ready indicator is illuminated and the MTS is ready for operation.

4. Pressing ON LINE after the Ready indicator is lit enables the MTS to accept commands from the user.

2.6.1.1 Semi-Automatic Threading

A semi-automatic threading procedure is provided. The semi-automatic sequence is initialized like the automatic procedure but is entered by pressing LOAD/REWIND a second time before actual tape leader positioning begins (approximately 4 seconds after the first press). The MTS pauses to allow manual positioning of the tape leader in the entrance of the tape threading path. The blower remains on to facilitate positioning.

Once the leader has been positioned, pressing LOAD/REWIND a third time allows the sequence to resume. 30 seconds is allowed for manual tape positioning: If, at the end of this time, LOAD/REWIND is not pressed the third time and tape is sensed in the tape threading path, the sequence continues automatically; but if tape is not sensed, the blower turns off and the MTS returns to idle mode without posting a fault code.

In the case of a horizontal mount, the semi-automatic thread procedure is required on every load. Since pressing LOAD/REWIND may be cumbersome, a Horizontal Mount Option may be enabled (Section 3.5.2). When enabled, the threading sequence pauses, without pressing LOAD/REWIND a second time, every time the MTS is loaded.

2.6.1.2 Manual Threading

If the event of a blower motor failure, the MTS cannot perform an automatic or semi-automatic threading sequence but it can perform read and write operations if the tape is threaded manually.

Power up the MTS; the swing arms automatically extend and then retract. With both the machine reel cover and the thread cover open and the file reel secured to the hub, slowly turn the file reel clockwise (CW) until the tape leader slips down into the thread path. With the palm turned upward, grasp the tape leader between the index and middle fingers and pull the tape through the thread path as shown in Figure 2-2 and onto the machine reel hub.

Use a finger to hold the tape leader against the machine reel hub and turn the hub clockwise (CW) until the tape catches itself. Press LOAD/REWIND and the MTS performs an automatic search for BOT.

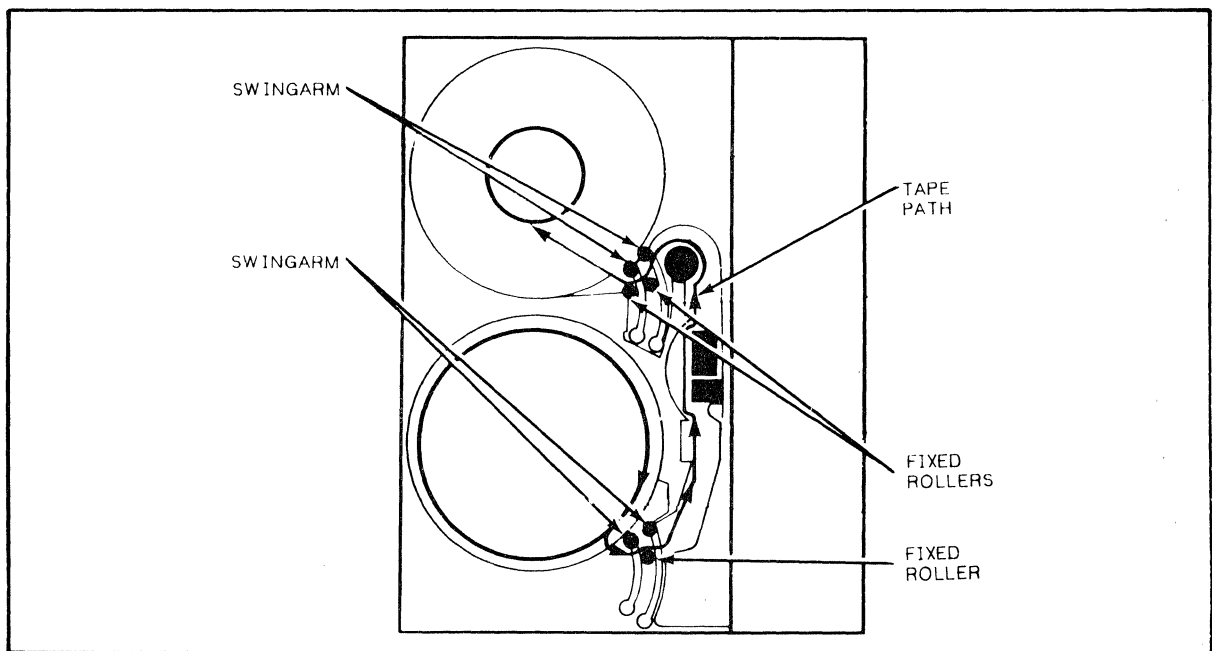

Figure 2-2. Tape Thread Path

2.6.2 REWIND

1. If the MTS is in Online Status, press RESET.
2. Press LOAD/REWIND. Tape rewinds at high speed, passes BOT, stops, moves forward to the BOT marker, and stops in Ready Status.

2.6.3 UNLOAD

1. If the MTS is in Online Status, press RESET.
2. Press REWIND/UNLOAD. If tape is positioned off BOT, it will rewind at high speed, pass BOT, stop, and move forward to the BOT marker. With tape at BOT, the swing arms retract, tape is unloaded onto the file reel, and power for the reel motors is turned off.

2.7 OPERATOR MAINTENANCE

There are several operator maintenance procedures which should be performed daily or after each eight-hour shift under normal operating conditions.

Because cleanliness is crucial to successful magnetic tape operations, these procedures are for cleaning components of the tape path (Figure 2-3). Cleaning should be done using only Storage Technology Hub and Transport Cleaner Fluid to moisten a lint-free cloth or foam-tipped swab. Refer to Appendix B for the part number of the cleaning supplies. After applying cleaner, allow a few minutes for excess fluid to evaporate before mounting a tape.

2.7.1 READ/WRITE HEAD AND TAPE CLEANER BLOCK

Clean the read/write head and the tape cleaner block using a lint-free cloth moistened with Hub and Transport Cleaner Fluid. Make certain the head and cleaner block are free of oxide deposits. Use foam-tipped swabs to clean the cleaner block.

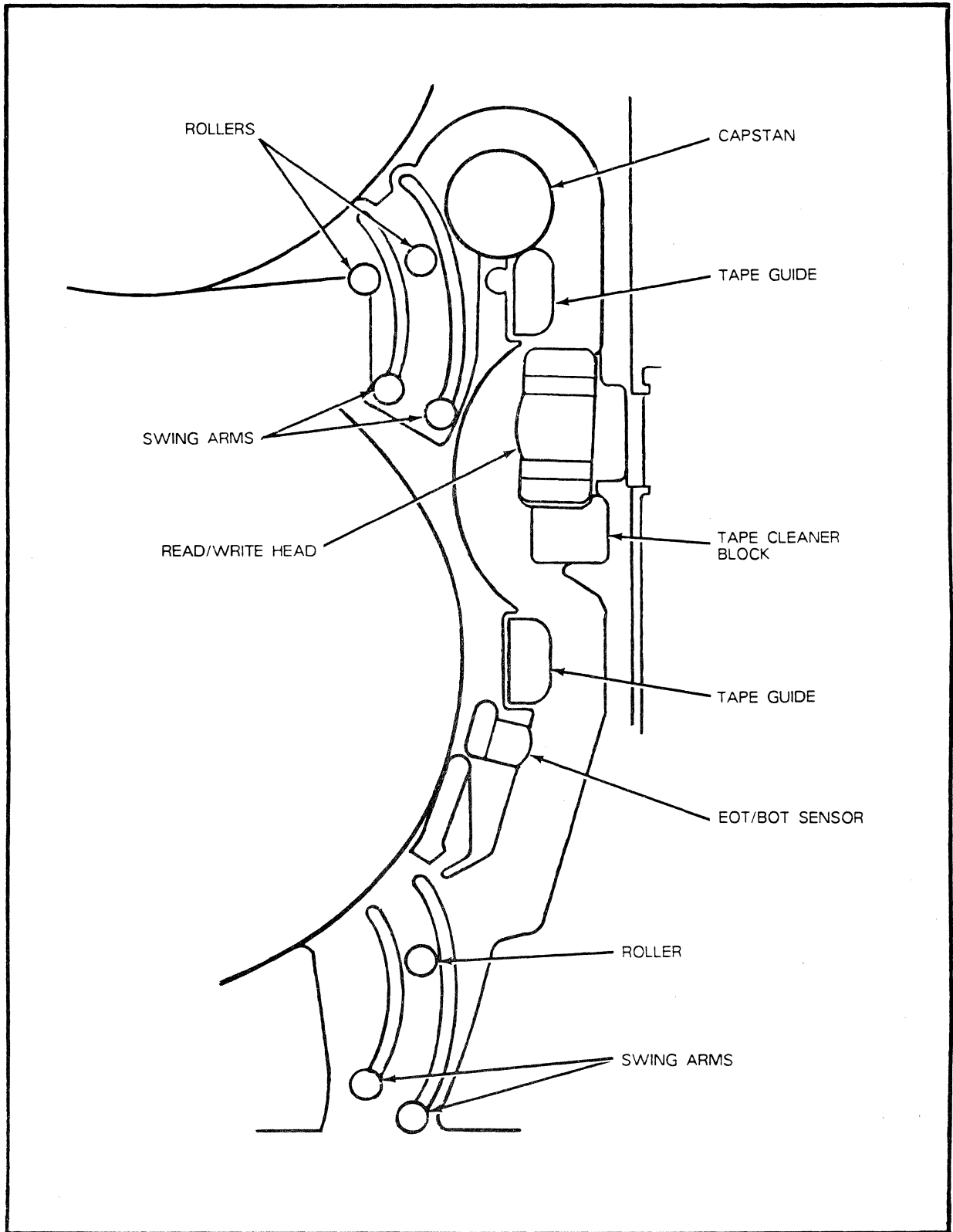

Figure 2-3. Tape Path Components

2.7.2 EOT/BOT AND LEADER SENSORS

Clean the EOT/BOT and leader sensor windows using a foam-tipped swab moistened with Hub and Transport Cleaner Fluid. Allow time for complete drying and remove any residue with a dry swab.

2.7.3 TAPE GUIDES, ROLLERS, AND SWING ARMS

Clean the two tape guides, the three rollers, and the four swing arms using a lint-free cloth moistened with Hub and Transport Cleaner Fluid. To reach otherwise inaccessible areas, foam-tipped swabs may be used. If necessary, the edge of a data processing card may be used to clean the flange corners of the guides.

2.7.4 CAPSTAN

Clean the capstan using a lint-free cloth wrapped around the index finger and moistened with Hub and Transport Cleaner Fluid.

```
////////////////////  
//// CAUTION ////  
////////////////////
```

Do not touch the outer, tape-contacting surface of the capstan with the bare hand as the surface is sensitive to contamination. Always use a cloth when handling the capstan and grip only the hub of the capstan.

With the free hand, slowly rotate the capstan hub while wiping the capstan surface with the moistened cloth. Two or three revolutions is sufficient. Wipe the capstan with a dry, lint-free cloth to remove excess cleaner fluid.

2.7.5 FILE REEL HUB

Clean the expansion surface of the file reel hub using a lint-free cloth moistened with Hub and Transport Cleaner Fluid.

CHAPTER 3
INSTALLATION

3.1 INTRODUCTION

This chapter provides instructions for inspection, power set up, preliminary checkout, and cabinet mounting of the MTS.

Each MTS is shipped on a foam cushion shipping pallet assembly with a corrugated overcarton. The container provides stability and protection for the MTS and should not be removed until the unit is ready to be mounted into an equipment rack. Provision has been made for an operational checkout of the MTS while on the shipping pallet.

3.2 INSPECTION

1. Position the packaged MTS upright at the operational checkout station.

////////////////////
//// WARNING ////
////////////////////

The MTS and its shipping carton weigh approximately 150 pounds (68 kg). Use appropriate mechanical aids and sufficient personnel when moving the unit to prevent personnel injury or equipment damage.

2. Remove the unpacking instructions and any other documents from the exterior of the shipping carton.
3. Visually inspect the exterior of the shipping carton for evidence of physical damage that may have occurred in transit.
4. Remove only the top of the shipping container (corrugated carton, corrugated inner tray, and top foam cushion). The MTS should be sitting upright, supported by the bottom of the cushion pallet assembly. Do not lay the MTS on its side.
5. Remove the front cushion foam from the lower front area of the cushion pallet. This permits access to the front of the MTS.

6. Locate and open the taped end of the antistatic polybag. Pull the bag completely down around the sides of the MTS. Cut the polybag as necessary to permit free opening of the front door of the MTS. Do not attempt to remove the polybag from under the MTS until ready to mount the unit in a rack.
7. Check all items against the shipping list to verify container contents. Verify that the serial number of the unit corresponds to that on the shipping invoice. Contact a company representative in case of a packing shortage or incorrect serial number.
8. Visually inspect the MTS for evidence of physical damage that may have occurred during handling or in transit.
9. Open the front door of the MTS and remove any cellophane and tape.
10. Remove all packing materials from cables and connectors. Check for bent or misaligned pins and straighten as necessary.
11. Verify that all cable connections are tight. (Refer to Figure 3-1.)
12. Check for loose hardware throughout the MTS and tighten as necessary. Ensure that all DIP packages on the circuit cards in the card cage are secure in their sockets.

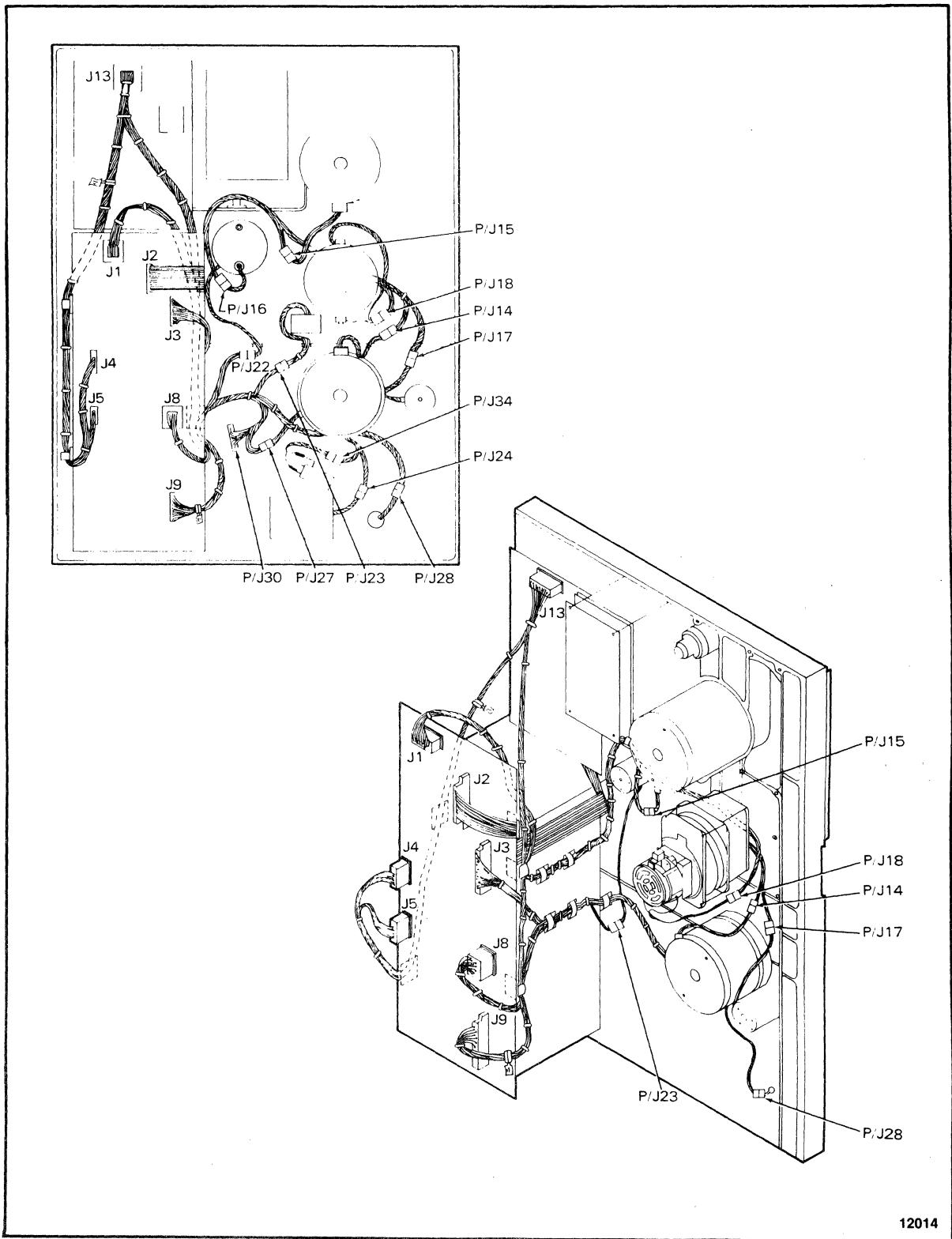

Figure 3-1. Internal Cabling

3.3 POWER CONNECTION

Verify that the facility AC power frequency and voltage matches that indicated on the CAUTION - HIGH VOLTAGE label on the MTS before connecting the unit to the facility power.

The input frequency rating for the unit is determined by the frequency option installed at the time of manufacture.

The input voltage rating for the unit is determined by the connection on the PK card of the AC harness wire labeled either 'X' or 'PKX' and may be easily changed in the field:

For 100 Vac 60 Hz input, the wire must be on terminal 6.
For 120 Vac 60 Hz input, the wire must be on terminal 4.

For 200 Vac 50 Hz input, the wire must be on terminal 6.
For 220 Vac 50 Hz input, the wire must be on terminal 4.
For 240 Vac 50 Hz input, the wire must be on terminal 2.

If this wire is moved in order to change the input voltage rating of the unit, ensure that the indication on the CAUTION - HIGH VOLTAGE label accurately reflects the new configuration.

The MTS is equipped with a three-conductor power cable. The card cage and the deck casting are connected to the safety ground of the power cord. The center pin of the power plug is the ground connection.

3.4 PRELIMINARY CHECKOUT

The preliminary checkout tests the major electrical functions of the MTS offline before it is installed in an equipment rack. Test the MTS on the cushion pallet assembly and without connections to the CPU.

1. Ensure the Power On/Off switch is off, then plug the power cord into the facility power.

```
////////////////////  
//// WARNING ////  
////////////////////
```

Do not touch any other part of the MTS when turning on.

2. Set the circuit breaker to ON.

3. Press on the operator panel Power On/Off switch. The cooling fans in the top of the electronics cage should turn on and MTS power-on diagnostics will be initiated.
4. Without a tape on the file reel hub, press LOAD/REWIND. The threading vacuum blower will come on and the machine reel will rotate as if in a tape threading sequence. Since tape present will not be detected, the operation will halt and the Machine Check indicator will flash, indicating a load failure. Press RESET to enable the MTS again.
5. Mount a reel of work tape onto the file hub with the tape leader end positioned at the threading channel. Press LOAD/REWIND and ensure that the tape threads and loads properly. The threading door must be closed with all catches firmly engaged.

If the tape threads and loads correctly, the EOT/BOT indicator should be illuminated. If a write enable ring is installed, the File Protect indicator should not be illuminated.

6. Reel motion may be checked by completing the following steps. Terminate each step by pressing RESET.

Steady state forward motion can be initiated by entering the following at the diagnostic keypad: <ENTER DIAG>, <0>, <ENTER>.

Steady state backward motion can be initiated by entering: <ENTER DIAG>, <1>, <ENTER>.

Shoeshine motion can be initiated by entering: <ENTER DIAG>, <2>, <ENTER>. Shoeshine motion speed can be changed by continuing to press <ENTER>.

Start/stop motion (backward and forward) can be initiated by entering: <ENTER DIAG>, <3>, <ENTER>. Speed and direction can be changed by continuing to press <ENTER>.

7. Press REWIND/UNLOAD and ensure that the MTS rewinds to BOT and successfully unloads the reel of tape. Remove the reel of tape.
8. If the MTS is not to be rack mounted at this time, reinstall all packaging material removed in Section 3.2 to assure safe storage.

3.5 CABINET MOUNTING

The MTS is designed to be mounted in a standard 19-inch RETMA rack or universal cabinet with a minimum panel space of 29.8 inches (75.8 cm). Refer to Figure 3-2 for other installation dimensions.

3.5.1 VERTICAL MOUNT

1. Install the two half hinges on the mounting rails of the rack as shown in Figure 3-3 using two 10-32 x .750-inch screws with flat and lockwashers (supplied).

////////////////////
//// WARNING ////
////////////////////

The MTS weighs approximately 125 pounds (57 kg). Use appropriate mechanical aids and sufficient personnel when moving the unit to avoid personnel injury or equipment damage. A suggested lifting method is shown in Figure 3-4.

2. Lift the MTS from the cushion pallet assembly. Ensure that the antistatic polybag does not hang or pull on the MTS components causing damage.

////////////////////
//// CAUTION ////
////////////////////

Instability of the rack may occur when the deck casting is open. To prevent tipping, a 90 pound (40 kg) ballast may be secured to the bottom of the rack at the back. Any suitable alternative may be used if the possibility of the rack tipping is precluded.

3. Position the MTS near the hinges and slide the unit onto the hinge pins.
4. Loosen the lower screw of the top hinge and slide the keeper onto the top hinge on the MTS. Re-tighten the hinge screws to 45 inch-pounds torque. The deck is now locked into place and cannot slide off the hinges.
5. Connect the MTS chassis ground strap by placing the ground strap lug over the top screw of the top hinge on the back side of the mounting rail and securing with a 10-32 nut and lockwasher.

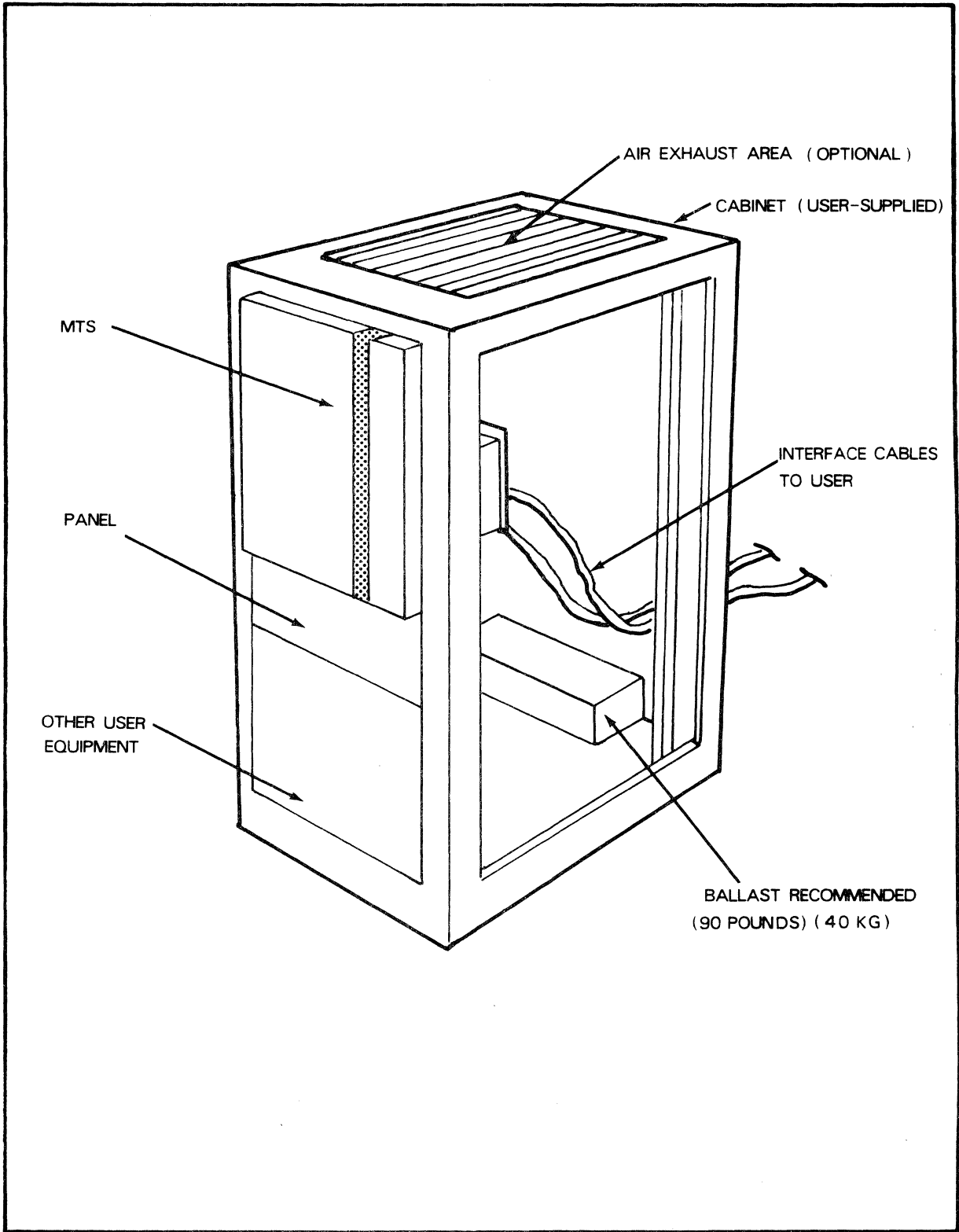

Figure 3-2. MTS Installation

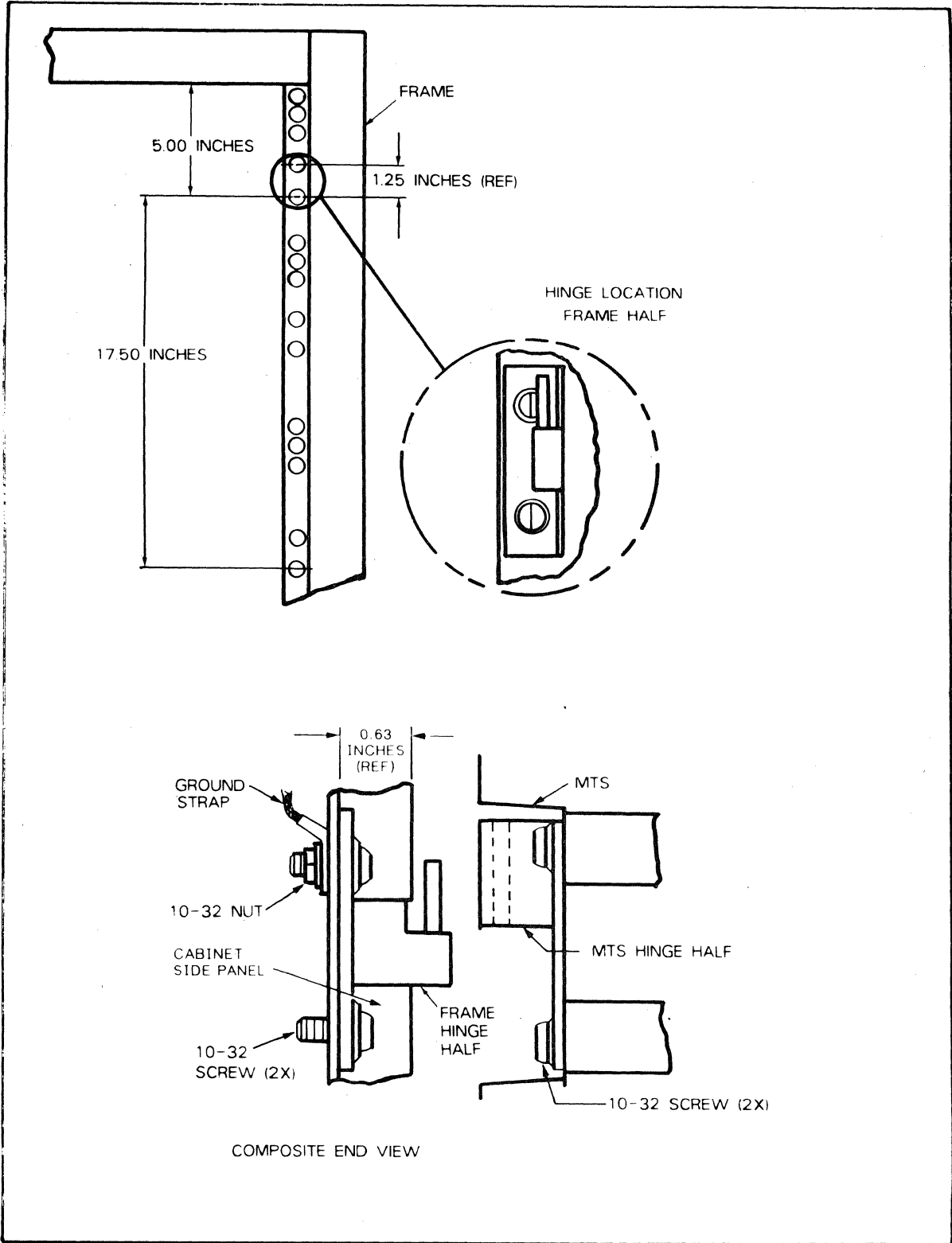

Figure 3-3. Mounting Dimensions

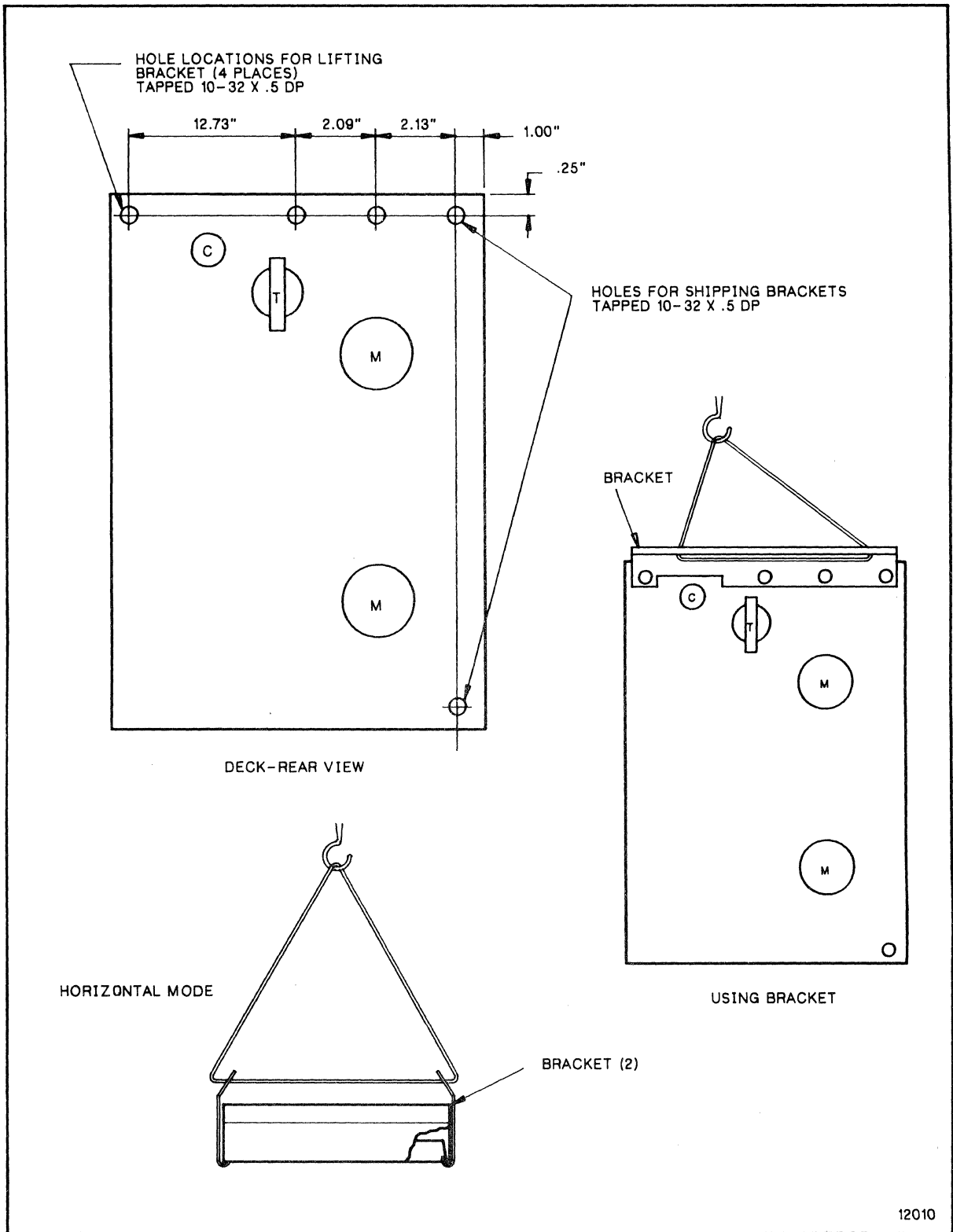

Figure 3-4. Suggested Lifting Methods

3.5.2 HORIZONTAL MOUNT

Horizontal mounting requires customer-designed mounting hardware to be compatible with the deck casting bosses provided for that purpose.

```
////////////////////  
//// WARNING ////  
////////////////////
```

The MTS weighs approximately 125 pounds (57 kg). Use appropriate mechanical aids and sufficient personnel when moving the unit to avoid personnel injury or equipment damage. A suggested lifting method is shown in Figure 3-4

Horizontal mounting requires the semi-automatic thread procedure on every tape load. Enabling the Horizontal Mount Option causes the load sequence to automatically pause for manual positioning of the tape leader without pressing LOAD/REWIND a second time. To enable this option, set the appropriate DIP switch on the IF card (slot A3) to the OFF position. Refer to Figure 3-5.

3.6 INTERFACE CABLING

Interface cables are not supplied with the MTS. Two cables are required using Spectra-Strip 455-248-60 60-conductor twisted-pair cable and Spectra-Strip 802-060 60-pin connectors. The maximum cable length from the USER CPU to the last MTS in the string is 40 feet (12 meters). Refer to Figures 3-6 and 3-7.

Terminators are required only on the IF card (slot A3) of the last (or only) MTS in the string and must be removed from any other MTS units in the string. Refer to Figure 3-5 for the locations of the terminators.

3.7 ADDRESS SELECTION

The address of the MTS is selected by setting the appropriate DIP switches on the IF card (slot A3). Refer to Figure 3-5.

3.8 RESHIPPING

If the MTS requires reshipping, Field Bill 68224 supplies the necessary parts and Field Instruction 68223 contains detailed instructions to ensure that the MTS is shipped without damage.

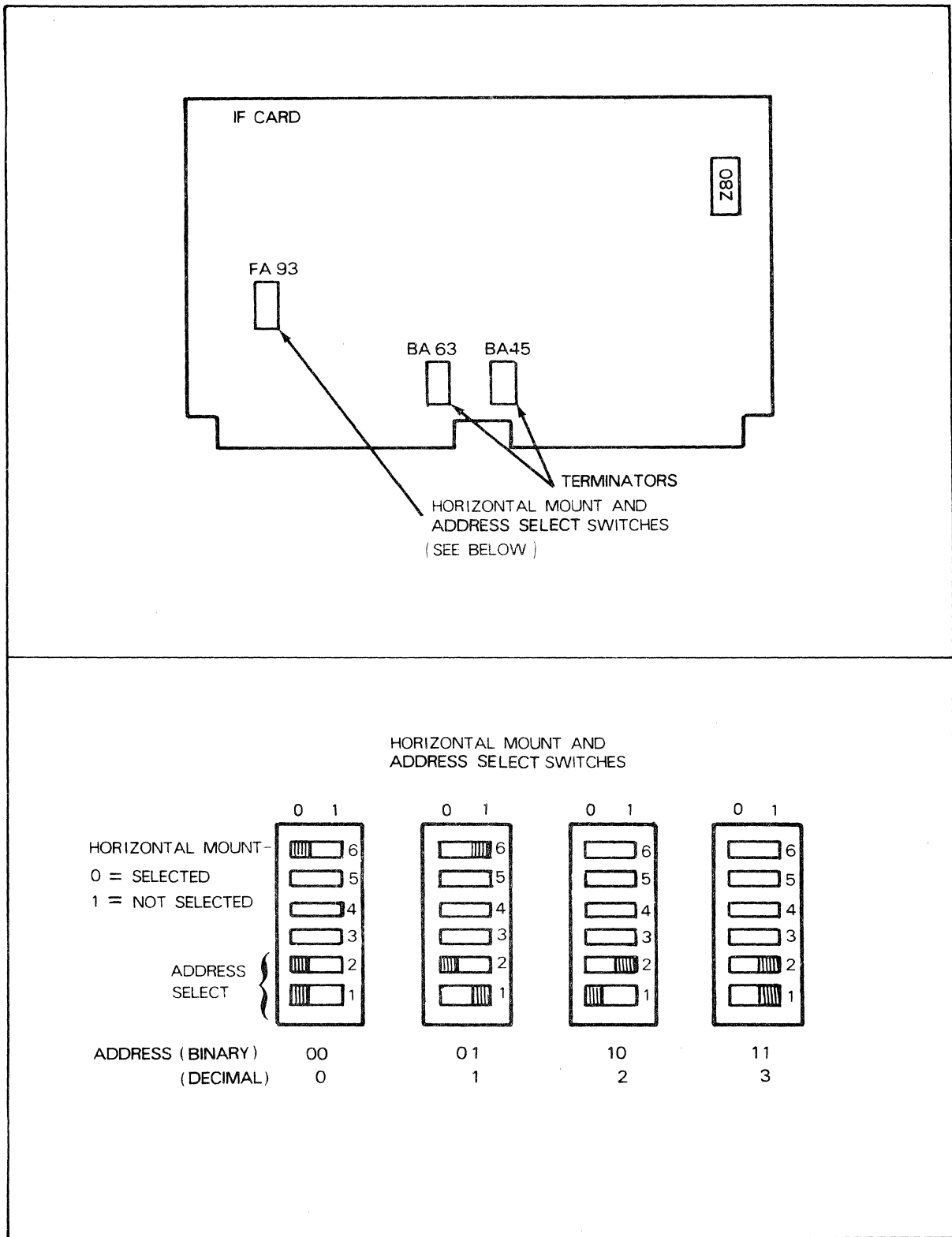

Figure 3-5. IF Card

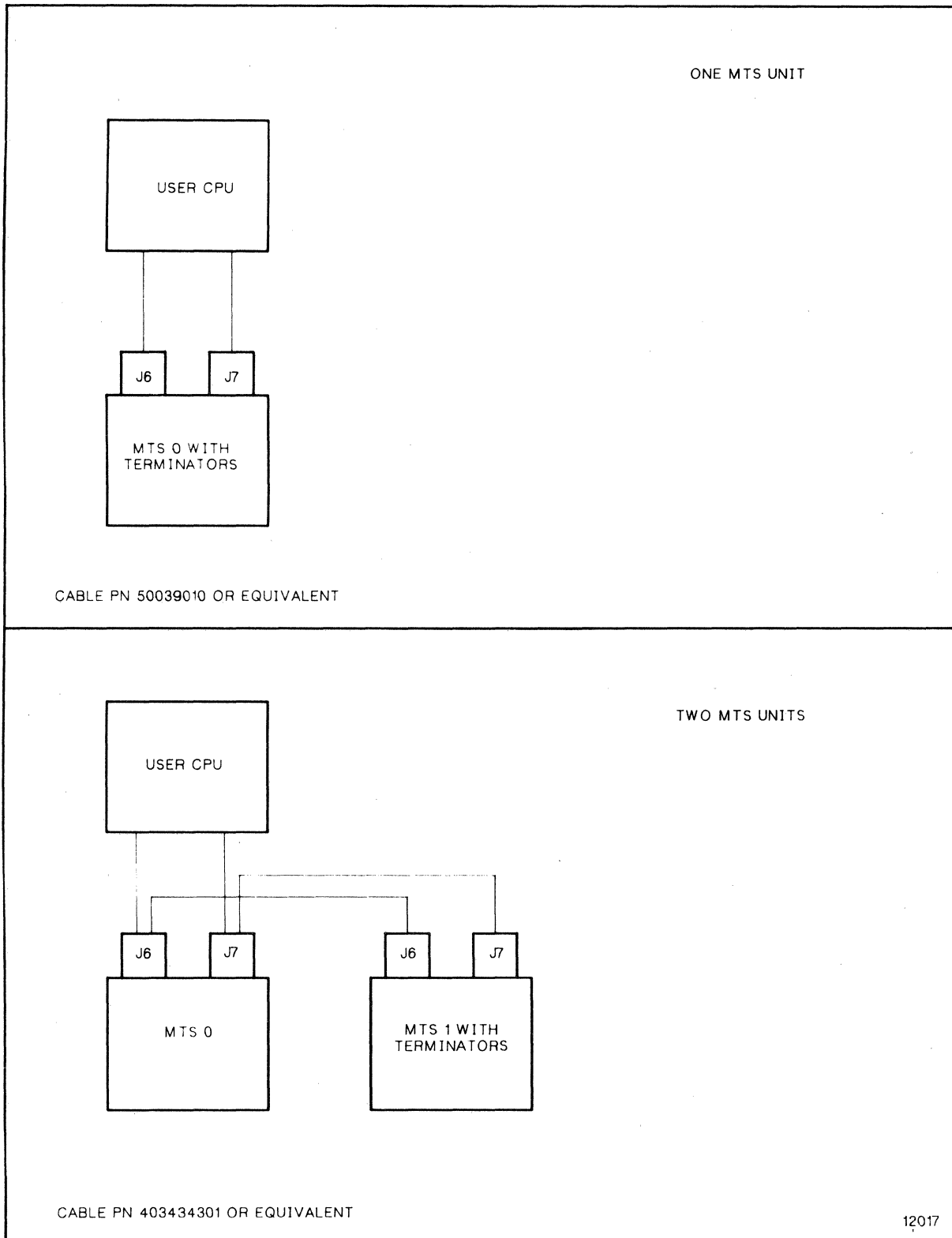

Figure 3-6. MTS Interface Cabling
(Sheet 1 of 2)

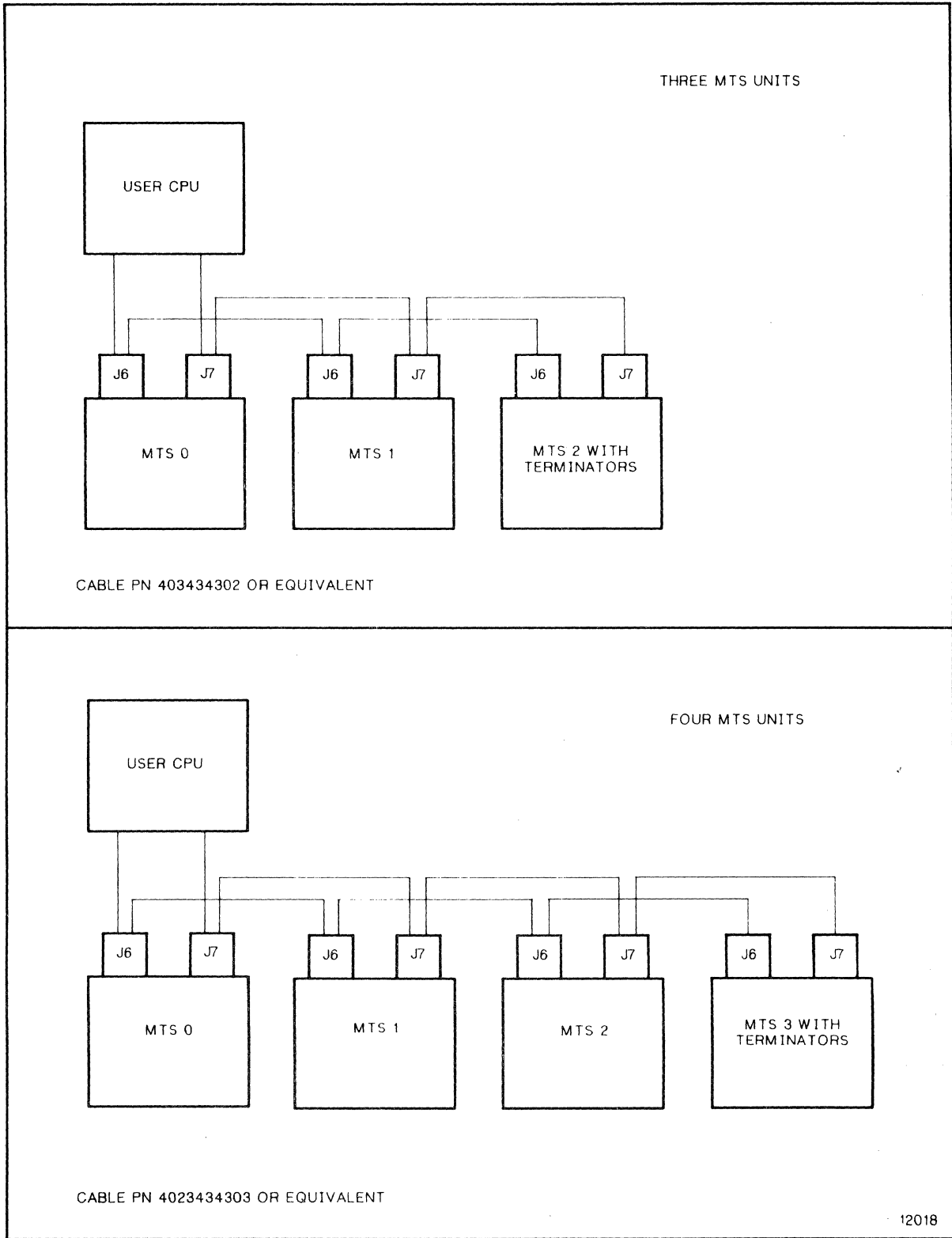

Figure 3-6. MTS Interface Cabling
(Sheet 2 of 2)

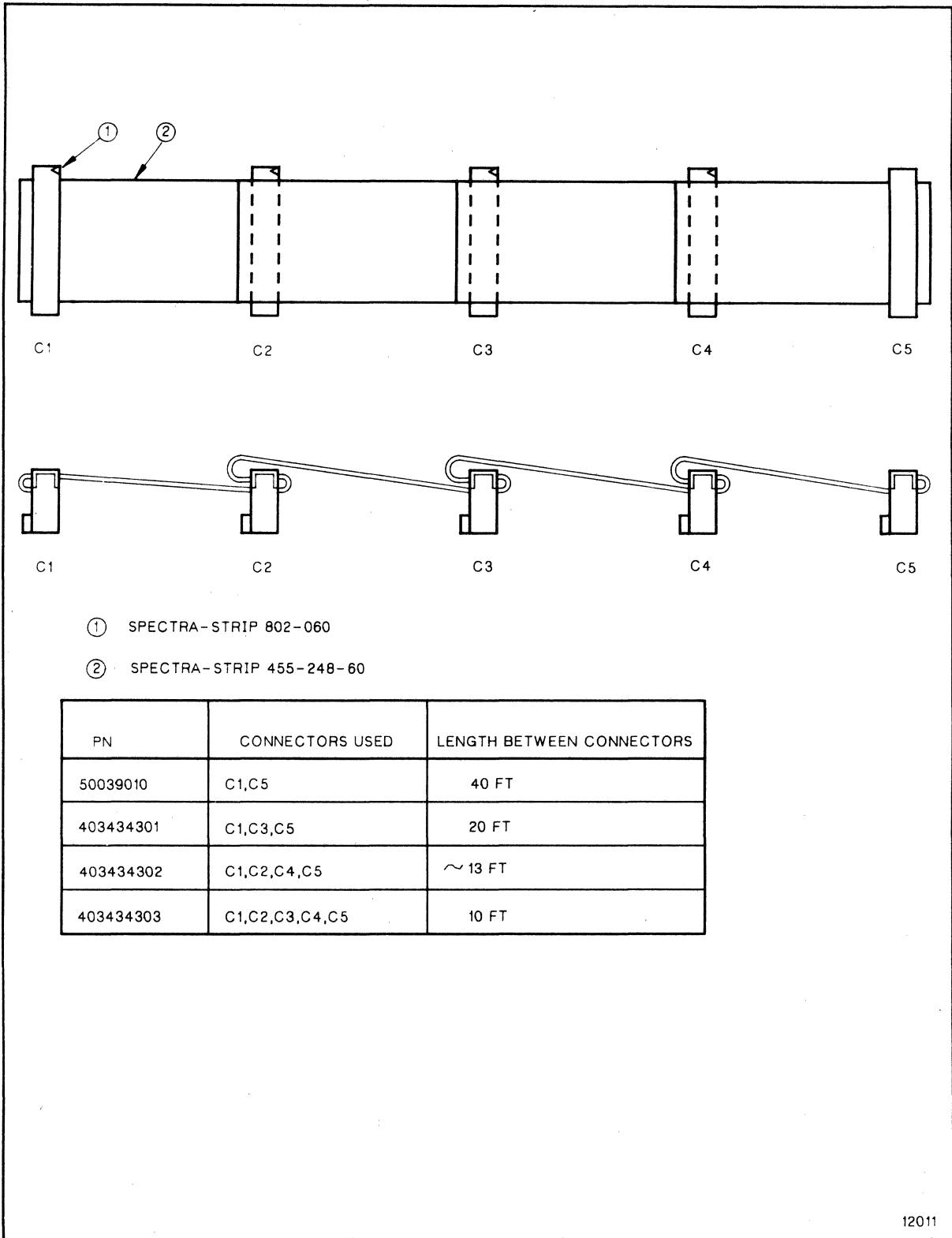

Figure 3-7. MTS Interface Cables

CHAPTER 4

INTERFACE

4.1 INTRODUCTION

This chapter provides a description of the MTS-USER interface circuits, defines the MTS-USER interface signals, and describes the USER commands to the MTS.

The MTS and USER interface connections are shown in Tables 4-1 and 4-2. The MTS and USER interface circuits are shown in Figure 4-1. The maximum allowable cable length from the USER system to the last MTS in a chain is 40 feet. is 20 feet (6 meters).

The interface signal levels are:

Unasserted (Reset) = +3.4 (± 0.3) Vdc = nonselected line
Asserted (Set) = 0 (< 0.7) Vdc = selected line

The interface resistive termination for each signal is 390 ohms to ground and 180 ohms to +5 Vdc. The termination for each signal line is provided in the MTS or required of the USER interface or both. The termination includes a ground wire, connected in both the MTS and the USER interfaces. Only the last MTS in a chain contains terminators.

4.2 DEFINITIONS

The following input line definitions are for functional mode only. The timing specifications given refer to measurements made at the standard interface connector.

4.2.1 MTS ADDRESS (AD0, AD1)

The two MTS Address lines are decoded to select one of the four possible MTSs. Refer to Table 4-3.

If the MTS is not busy (the BUSY line is not asserted), the address lines may be changed at will to select a different MTS and thus view a different set of MTS status lines. The delay time between the selection of a new MTS and stabilization of the MTS status lines is 150 nanoseconds maximum.

For command operations, the MTS Address lines must be stable 90 nanoseconds prior to the assertion of Start, remain stable until the selected MTS responds by asserting BUSY, and not change while Busy is asserted.

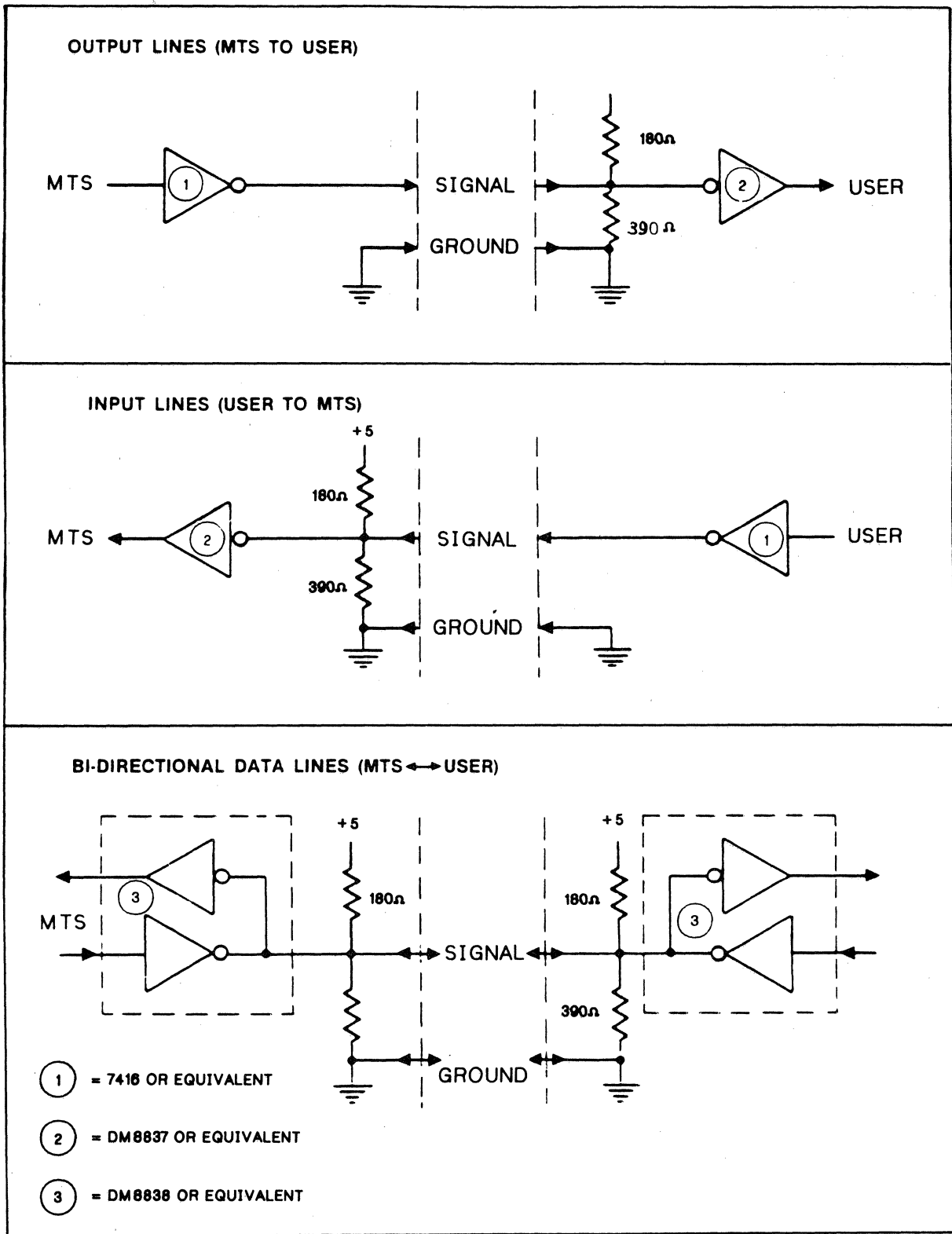

Figure 4-1. MTS-USER Interface Circuits

Table 4-3. MTU Address Line Decode

MTS ADDRESS LINES		SELECTED MTS
AD1	AD0	
0	0	0
0	1	1
1	0	2
1	1	3

4.2.3 COMMAND SELECT (CMD0, CMD1, CMD2, CMD3)

The four Command Select lines are decoded in the MTS and cause one of 16 command operations. These lines must be stable 90 nanoseconds prior to the assertion of START and must remain stable until the MTS responds by asserting Busy. Command Select decoding is shown in Table 4-4. The detail descriptions and timing of each command operation are specified in Section 4-4.

Table 4-4. Command Select Decode

CMD0	CMD1	CMD2	CMD3	MNEMONIC	DESCRIPTION
0	0	0	0	NOP	No Operation
0	0	0	1	CLR	Drive Clear
0	0	1	0	DMS	Diagnostic Mode Set
0	0	1	1	SNS	Sense Drive Status
0	1	0	0	RDF	Read Forward a Block
0	1	0	1	RDB	Read Backward a Block
0	1	1	0	WRT	Write a Data Block
0	1	1	1	LWR	Loop Write-to-Read
1	0	0	0	BSF	Backspace a File
1	0	0	1	BSB	Backspace a Block
1	0	1	0	FSF	Forward Space a File
1	0	1	1	FSB	Forward Space a Block
1	1	0	0	WTM	Write Tape Mark
1	1	0	1	ERG	Erase Gap
1	1	1	0	REW	Rewind
1	1	1	1	RUN	Rewind and Unload

4.2.4 DENSITY SELECT (DS0, DS1)

A switch on the MTS operator panel is used to select 1600 bpi (PE), 6250 bpi (GCR), or System Select recording density. With 1600 or 6250 bpi selected and tape positioned at BOT, the MTS generates tapes written in the selected density. With System Select and tape positioned at BOT, the MTS generates tapes written in the density selected by the Density Select lines. The Density Select lines must be stable 90 nanoseconds prior to the assertion of START and remain stable until the MTS responds by asserting BUSY. The decode of the Density Select lines is shown in Table 4-5.

Table 4-5. Density Select Line Decode

DENSITY SELECT LINES		SELECTED DENSITY
DS1	DS0	
0	0	1600 (PE)
0	1	6250 (GCR)

The MTS recording density can be altered only at the time of a write command issued with tape positioned at BOT. At all other times, the MTS reads and writes the density indicated by the ID burst of the tape in use.

4.2.5 TRANSFER ACKNOWLEDGE (TRAK)

The assertion of the Transfer Acknowledge line by the USER is in response to the assertion of TREQ by the MTS. The assertion of TREQ by the MTS on a WRT operation indicates that the MTS is requesting data character transfer on the Bi-Directional Data bus and the responding assertion of TRAK (or STOP) by the USER indicates that the Bi-Directional Data bus contains the valid data character to be accepted.

The assertion of TREQ by the MTS on a RDF or RDB operation indicates that a data character is valid on the Bi-Directional Data bus and the responding assertion of TRAK (or Stop) by the USER indicates that the data character has been transferred.

The signal protocol for TREQ and TRAK is similar for either a write or a read operation, that is, once TREQ is asserted it remains asserted until TRAK or STOP is asserted. TRAK must remain asserted until TREQ is reset at which time TRAK must be reset.

4.2.6 TERMINATE COMMAND (STOP)

The Terminate Command line is asserted by the USER in response to TREQ or BLOCK to indicate one of the following situations:

1. During a WRT or LWR command in response to TREQ, that the last data character to be written in the data block has been placed on the Bi-Directional Data bus.
2. On a RDF or RDB command in response to TREQ, that the MTS is to terminate the transfer of data characters on the Bi-Directional Data bus.
3. On a BSB or FSB operation in response to BLOCK, that the MTS is to terminate spacing over blocks. (Refer to Section 4.4.10.2.)

For the first two situations, STOP replaces TRAK (see Section 4.2.5) as the USER response to TREQ. In response to STOP, the MTS terminates the command in progress and resets BUSY, but only after the MTS has completed the necessary tape formatting, deframing, and positioning according to the nature of the command in progress.

4.2.7 SYSTEM RESET (RESET)

The assertion of System Reset by the USER causes the MTS to immediately terminate any command in progress. BUSY is asserted until the completion of the reset procedure. No command is accepted while BUSY is asserted. Between the assertion of RESET and the clearing of BUSY, status output lines are reset.

During termination, the MTS discontinues formatting and deframing, and causes tape motion to halt without regard to IBG positioning. (Note: Partially written or erased blocks during write commands may occur when a RESET is given.) If the system is in diagnostic mode, it is set to functional mode.

The RESET pulse from the USER interface must be 1 microsecond minimum.

4.2.8 SELECT MULTIPLEX (SLX0, SLX1, SLX2)

The three Select Multiplex lines are decoded in the MTS and determine which of four 9-bit registers is multiplexed to the Error Multiplex (ERRMX) output lines. The ERRMX lines are valid only as a part of the ending status (that is, after BUSY has been reset). The delay time between the selection of a Select Multiplex code and the stabilization of the selected mux byte is 150 nanoseconds maximum. Table 4-6 shows the Select Multiplex decode. More complete descriptions of each byte are given in Section 4.3.15.

Table 4-6. Select Multiplex Decode

SLX2	SLX1	SLX0	MUX BYTE	DESCRIPTION
0	0	0	0	Dead Tracks
0	0	1	1	Read/Write Errors
0	1	0	2	Diagnostic Aids
0	1	1	3	Drive Sense Byte

4.2.9 BI-DIRECTIONAL DATA (DATA 0-7,P)

The nine Bi-Directional Data lines are used to transfer the data characters between the interfaces in conjunction with the TRAK (or STOP) responses to TREQ. When a line is asserted, a ONE bit is transferred between the interfaces and when a line is reset, a ZERO bit is transferred. Odd parity must be maintained on these lines for all functional mode data transfer operations. Data bit 7 is the least significant bit; data bit 0 is the most significant. The data lines must be stable 90 nanoseconds prior to the assertion of TRAK (or STOP) during a write operation or TREQ during a read operation.

4.3 OUTPUT SIGNAL DEFINITIONS

The following output line definitions are for functional mode only.

4.3.1 TRANSFER REQUEST (TREQ)

The Transfer Request line is asserted by the MTS to request data character transfer on the Bi-Directional Data bus. The signal protocol for TREQ and TRAK (or STOP) is specified in Sections 4.2.5 and 4.2.6.

4.3.2 EXPECTING DATA (RECV)

The Expecting Data line is asserted by the MTS to indicate that the Bi-Directional Data bus is under control of the USER interface and that the MTS will receive data character transfers. This line is asserted on WRT or LWR command operations only. It remains asserted until a new command is initiated.

4.3.3 BLOCK SENSED (BLOCK)

The Block Sensed line is asserted by the MTS to indicate that a data block or a tape mark block has been detected. This line is asserted during BSB and FSB commands or during any read type command detecting a tape mark block. BLOCK is a pulse of 400 nanoseconds nominal duration.

4.3.4 OSCILLATOR (OSC)

The Oscillator line is derived from the internal MTS crystal oscillator. The frequency is 2.5 MHz (400 nanosecond period).

4.3.5 END OF DATA PULSE (ENDATP)

The End of Data Pulse line is asserted by the MTS to indicate that the last data character has been read from tape and transferred to the USER. ENDATP is asserted on read command operations (RDF or RDB) only. The ENDATP pulse is 800 nanoseconds in duration.

4.3.6 BUSY (BUSY)

The Busy line is asserted by the MTS following the acceptance of the command initiated by START. This line remains asserted until completion of the command operation or until conditions arise which cause a REJECT. A command operation maybe initiated only when BUSY is reset.

4.3.7 IDENTIFICATION BURST (ID BRST)

The Identification Burst line is asserted by the MTS to indicate that an identification burst procedure is being performed by the MTS. It is asserted on read or write commands from BOT. ID BRST is asserted only while the identification burst procedure is being performed.

On a read command, the procedure includes the determination of the format (PE or GCR) of the burst.

If the ID burst procedure is performed satisfactorily, the MTS proceeds with the command initiated. If the procedure is not performed satisfactorily, REJECT and a reject code (Section 4.3.15) are asserted. ID BRST remains asserted. ID BRST is also asserted if a backward operation is initiated with tape positioned off BOT and tape reaches either BOT or an ARA ID burst before the end of the operation. (Under this condition, DATA CHK is also set).

4.3.8 TAPE MARK STATUS (TMS)

The Tape Mark Status line is asserted by the MTS to indicate that a tape mark block has been detected. This line is asserted following a Write Tape Mark command and following any read or space command when a tape mark block is detected. TMS is reset by the next command issued unless that command is a CLR, SNS, or NOP.

4.3.9 COMMAND REJECT (REJECT)

The Command Reject line is asserted by the MTS whenever conditions within the MTS are inappropriate to the command operation. The conditions which cause REJECT are given in Section 4.3.15 under the Error Multiplex bus definitions. After the assertion of REJECT and the reset of BUSY, reject codes for the

conditions causing the reject are the octal contents of the diagnostic aids register, addressable on the Error Multiplex bus as MUX Byte 2. Read or write commands given after REJECT is received may result in mispositioning and/or creation of an unreadable portion of tape.

4.3.10 OPERATION INCOMPLETE (OP INC)

The Operation Incomplete line is asserted by the MTS in conjunction with the reject codes in MUX Byte 2 (Section 4.3.15.3). OP INC indicates that the given command was initiated but was not completed. REJECT includes those commands that were not able to be initiated as well as those not completed.

4.3.11 OVERRUN STATUS (OVRNS)

During a write operation, the Overrun Status line is asserted by the MTS when the write buffer of the MTS is not being supplied data characters by the USER as fast as the MTS requires them. This may occur when previous TREQ/TRAK responses were not within the timing requirements or when STOP was not asserted. The data block written will be incorrectly encoded. If OVRNS is asserted, DATA CHK is also asserted following the read validity checking.

During a read operation, OVRNS is asserted by the MTS when data characters have backed up in and overflowed the MTS buffer due to the USER not accepting data at a high enough rate.

4.3.12 EPROM ERROR (ROMPS)

The EPROM Error line is asserted by the MTS to indicate that an error in the microprogram code was detected after a diagnostic check sum was performed.

4.3.13 SLAVE STATUS CHANGE (SSC)

The Slave Status Change line is asserted by the MTS to indicate that it has gone online, gone offline, or gone from not ready to ready. SSC is reset after issuing any command (other than a NOP or SNS) to the MTS that had one of these three status changes.

4.3.14 DATA CHECK (DATA CHK)

The Data Check line is asserted by the MTS to indicate that one or more of the error conditions of Table 4-7 has occurred. References to more detailed descriptions of each error are included in the table.

Table 4-7. Error Conditions Setting DATA CHK

ERROR CONDITION	REFERENCE SECTION
CRC Error	6.2.15.2, item 1
Write Tape Mark Check	6.2.15.2, item 2
Uncorrectable Error	6.2.15.2, item 3
Partial Record	6.2.15.2, item 4
Multiple Track Error	6.2.15.2, item 5
End of Data Check	6.2.15.2, item 6
Velocity Error	6.2.15.2, item 7
Overrun	6.2.11
BOT Reached	Note 1
PE Postamble Error	Note 2
Single Track Error	Note 3

1 This error indicates that a backward command was initiated tape positioned off BOT and BOT was reached before the command was completed. ID BRST and BOTS are also set.
2 During PE read or write operations, the postamble was not detected to be the correct length.
3 During a PE write operation, an error detected in any track will set DATA CHK.

4.3.15 ERROR MULTIPLEX (ERRMX 0-7,P)

The nine Error Multiplex lines are asserted by the MTS to allow transfer of additional error and reject status information. The lines are valid only as a part of the ending status of the most recently completed command (that is, after BUSY is reset). One of four registers is multiplexed to the ERRMX bus as selected by SLX0, SLX1, and SLX2 (Section 4.2.8). Table 4-8 gives the ERRMX decode for functional mode operation.

Table 4-8. Error Multiplex Bus Decode for Functional Mode

MUX BYTE	ERROR MULTIPLEX BIT									DESCRIPTION
	P	7	6	5	4	3	2	1	0	
0	DTP	DT7	DT6	DT5	DT4	DT3	DT2	DT1	DT0	Dead Track
1	CRC ERR	WTM CHK	UCE	PART REC	MTE	NOT USED	END DATA CHK	VEL ERR	DIAG MODE LTCH	Read/Write Errors
2	TACH	DA7	DA6	DA5	DA4	DA3	DA2	DA1	DA0	Diagnostic Aid Bits
3	WRTS	EOTS	BOTS	NOT USED	FPTS	BWDS	HDNS	RDYS	ONLS	Status

4.3.15.1 Mux Byte 0

ERRMX bits P through 0 are asserted upon detecting a dead track during a read or a write operation. A dead track is caused by the inability to detect correct data on a specific track on tape. These bits are reset at the start of each new command.

4.3.15.2 Mux Byte 1

The following bits of Mux Byte 1 are asserted when the conditions defining the bit occur:

1. Cyclic Redundancy Character Error (CRC ERR)

The internal checks of data character CRC registers indicate a loss of data integrity. This error may occur during read or write operations in GCR or during write operations in PE. DATA CHK is also asserted.

2. Write Tape Mark Check (WTM CHK)

The MTS has been unable to write a tape mark correctly (see Section 4.4.13). DATA CHK and REJECT may also be asserted (Table 4-9).

Table 4-9. Status Lines Asserted with WTM CHK

ASSERTED LINES			COMMENTS
WTM CHK	DATA CHK	REJECT	
X	X		The tape mark written does not meet ANSI specifications but is readable as a TM.
X		X	The tape mark written is probably not readable as a TM. Noise may be left on tape and may not be detected by any read or space command.

3. Uncorrectable Error (UCE)

An uncorrectable error has been detected. This error may occur during PE or GCR read or write commands. DATA CHK is also asserted.

4. Partial Record (PART REC)

An IBG is detected before detecting end-of-data characters. This error may occur during PE or GCR read or write commands. DATA CHK is also asserted.

5. Multiple Track Error (MTE)

Two or more tracks are detected in error. This error may occur during PE or GCR read or write commands. DATA CHK is also asserted.

6. End of Data Check (END DATA CHK)

The end-of-data characters are not detected, or the preambles and postambles do not meet format requirements. This error may occur during PE or GCR read or write commands. DATA CHK is also asserted.

7. Velocity Error (VEL ERR)

The MTS speed indication was outside acceptable limits. This error may occur during PE or GCR write commands. DATA CHK is also asserted.

8. Diagnostic Mode Latch (DIAG MODE LTCH)

The diagnostic mode of operation has been set in the MTS.

4.3.15.3 Mux Byte 2

ERRMX bit P is the digital tachometer (TACH) from the MTS and contains information concerning tape speed and distance. This line is used in certain diagnostic routines and is valid during commands as well as after the command is completed.

ERRMX bits 7 and 6 (DA7 and DA6) are used during diagnostic mode operation only.

Various reject codes are asserted on bits 5 through 0 under their defining conditions. The reject code is the octal equivalent of bits DA5 through DA0 with bit DA5 being most significant and bit DA0 being least significant. Table 4-10 defines Reject Codes 1 through 37, and indicates those that set OP INC.

4.3.15.4 MUX Byte 3

Mux Byte 3 contains MTS status bits. These bits, with the exception of Backward Status (BWDS), are duplicated as separate interface output lines (Sections 4.3.18 through 4.3.24).

The Backward Status bit is asserted when the command in progress or just completed is a backward tape motion command. If the current or previous command is a forward tape motion command, this bit is unasserted.

Table 4-10. Reject Codes (Sheet 1 of 2)

REJECT CODE (OCTAL)	DESCRIPTION
1	The MTS is not in Ready Status.
2	Reserved
3*	The TRAK response to the initiating TREQ was not received within 75 milliseconds on a write-type command.
4	Reserved
5	The MTS is in File Protect Status when a write-type command is attempted.
6*	The MTS did not go to Erase Status only.
7	Command cannot be executed as given.
10*	The MTS did not go to Read Status.
11*	The MTS is unable to read a PE or GCR ID burst either during a read operation or during a read check while writing the ID burst.
12	Reserved
13	Reserved
14*	The MTS did not go to Write Status.
15	Reserved
16	Reserved
17*	Noise (possibly data) was detected during an Erase Gap command or during a Write command following a read-type command.
20*	The MTS is in Write Overrun Status at EOT.
21*	The MTS reset Ready Status.
22	Reserved
* OP INC is also set	

Table 4-10. Reject Codes (Sheet 2 of 2)

REJECT CODE (OCTAL)	DESCRIPTION
23	A backward-type command (except a rewind or a rewind/unload command) was given, but tape was already positioned at BOT.
24*	The ARA BURST portion of the GCR ID-burst just written did not have all nine tracks active.
25*	An IBG longer than 25 feet in PE mode or longer than 15 feet in GCR mode was detected on a read or space-type command.
26	Reserved
27	Reserved
30*	The MTS is not in the recording density selected.
31	LWR attempted when tape loaded and positioned off BOT
32*	No tape motion.
33*	During a readback check of a write operation, data was detected in an IBG area.
34	Reserved
35*	The MTS attempted to backspace over a bad record just written but was unable to detect the record.
36*	The ARA ID burst was unreadable during a GCR write command.
37*	During the readback check of a write or write tape mark command, no data was detected.
* OP INC is also set.	

4.3.16 CORRECTED ERROR (CRERR)

The Corrected Error line is asserted by the MTS to indicate:

1. A single-track error has been corrected during a PE read or a PE readback check during a write.
2. A single- or double-track error has been corrected during a GCR read or a GCR readback check during a write.

4.3.17 DATA BUS PARITY ERROR (BUPER)

The Data Bus Parity Error line is asserted by the MTS to indicate that the Bi-Directional Data Bus detected an even parity data character during a TREQ/TRAK data transfer. On WRT operations, assertion of this line indicates that the data written on tape is incorrect. On RDF or RDB operations, assertion of this line indicates either an uncorrectable read error or an internal malfunction of the MTS read data processing system. Data transmission is not halted in either write or read operations until the normal ending point is reached.

4.3.18 ONLINE STATUS (ONLS)

This line is asserted by the MTS when in Online Status. (The MTS may be in Online Status when it is not in Ready Status.) If the MTS is not in Online Status, all other status is invalid. The Online key is used to set the MTS to Online Status; the Reset key is used to reset Online Status

4.3.19 READY STATUS (RDYS)

This line is asserted by the MTS when in Ready Status. (The MTS is in Ready Status when it has tape loaded, is not rewinding, and is not in Machine Check Status.)

4.3.20 BEGINNING OF TAPE STATUS (BOTS)

The Beginning of Tape Status line is asserted by the MTS when tape is positioned at the BOT marker.

4.3.21 END OF TAPE STATUS (EOTS)

The End of Tape Status line is asserted by the MTS when the tape is positioned on or past the EOT marker, indicating that tape is within the end of recording area.

4.3.22 FILE PROTECT STATUS (FPTS)

The File Protect Status line is asserted by the MTS when tape is loaded and the file reel does not contain a write enable ring.

4.3.23 WRITE STATUS (WRTS)

This line is asserted by the MTS when in Write Status.

4.3.24 HIGH DENSITY STATUS (HDNS)

The High Density Status line indicates the recording format (density) in which the MTS is operating. HDNS set indicates GCR format; HDNS reset indicates PE format.

On read or space commands from BOT, the MTS first sets to PE mode, reads the ID burst, and then sets to the format indicated. Once positioned away from BOT, the MTS reads in the density previously determined by reading the ID burst of the tape in use.

On write operations from BOT, the MTS sets to the density selected by the USER (Section 4.2.5).

The MTS sets to PE mode whenever it has just been loaded, unloaded, or powered up.

4.3.25 REWINDING STATUS (REWS)

The Rewinding Status line is asserted by the MTS when in the process of rewinding tape to BOT (that is, the MTS is loaded and in Online Status but not in Ready Status).

4.4 FUNCTIONAL MODE COMMAND DESCRIPTIONS

4.4.1 GENERAL

The following command descriptions are for functional mode only.

4.4.1.1 Command Initiation

All commands are initiated by asserting the appropriate address, density, and command lines and then asserting START. The MTS Address, Density Select, and Command Select lines must be valid and stable for 90 nanoseconds minimum prior to the assertion of START. START must have had a reset duration of 90 nanoseconds minimum prior to assertion. Upon the assertion of START, the addressed MTS stores the density and command, asserts BUSY, and resets ending status from the previous operation. START must remain asserted until BUSY is asserted. Once BUSY is asserted, the Density Select, Command Select, and START lines may change state. START must be unasserted when the MTS Address lines are changed. Refer to Figure 4-2 for command initiation timing.

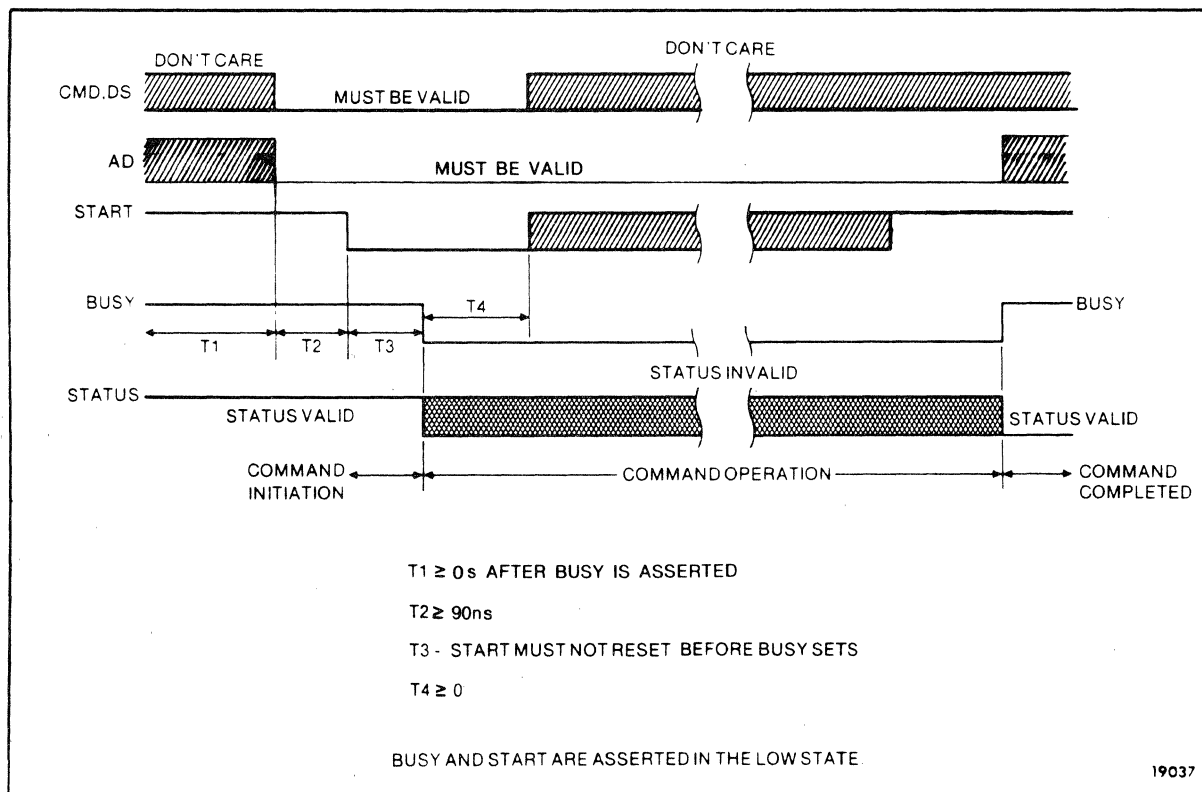

Figure 4-2. Command Initiation, Operation, and Completion

4.4.1.2 Reject Conditions

When reject conditions occur, as specified in Section 4.3.15.3, during the command operation, REJECT is asserted, BUSY resets, and the operation terminates.

4.4.1.3 Operation Completed

The command operation can only be considered as completed or terminated after BUSY is reset. A new command can be initiated only when BUSY is reset.

4.4.1.4 Ending Status Validity

All MTS status (and error) lines may change during an operation; however, all lines must be considered invalid while BUSY is asserted and valid only after completion of the operation when BUSY is reset (Figure 4-2).

4.4.1.5 End of Tape Status (EOTS)

EOTS (tape positioned in the end of recording area) does not affect, inhibit, or control command operations within the MTS. If forward-type commands are repeated (such as WRT) or allowed to continue (such as FSB) when EOTS is asserted and the physical end of tape is reached, the MTU goes not ready, the operation terminates, and REJECT is asserted. The tape will be completely removed from the file reel and require manual loading before a rewind can be performed.

4.4.1.6 Commands with MTS in Write Status

When a backward command (BSB, BSF, REW, RDB, RUN) is initiated and the addressed MTS is in Write Status, the MTS automatically causes an erasure of tape in the forward direction of 1.5 inches (nominal) before commencing the command operation.

Forward read commands (FSB, RDF, FSF) with the addressed MTS in Write Status are considered improper command sequences. (See Section 4.4.1.7.)

4.4.1.7 Improper Command Sequences

The tape area forward of a just completed write-type command (WRT, WTM, ERG) is erased for a short distance. When this erasure impinges into another block, this block is partially erased. Write-type commands followed by forward read commands are not prohibited but should be avoided or the user tape operating system should maintain knowledge of the condition.

4.4.2 NO OPERATION (NOP) COMMAND

NOP command operations perform essentially no function. The MTS error status outputs do not change. BUSY is asserted only for the short time necessary to accept and process the command.

Other than command initiation, no signal responses are required of the USER interface.

4.4.3 DRIVE CLEAR (CLR) COMMAND

CLR resets the OVRNS, DATA CHK, ID BRST, CRERR, BUPER, and ERRMS status outputs if they are asserted from the previous operation. CLR also resets SSC. The MTS remains in Online Status if previously in that state.

The functions of a Drive Clear command are always performed automatically by the MTS as the initial part of all commands except a NOP command.

Other than command initiation, no signal responses are required of the USER interface.

4.4.4 DIAGNOSTIC MODE SET (DMS) COMMAND

The DMS command causes the mode of operation within the MTS to be shifted from functional mode to diagnostic mode. Diagnostic mode to functional mode transfer is accomplished when the USER asserts the RESET line or when the MTS automatically transfers mode after certain diagnostic mode command sequences.

Other than command initiation, no signal responses are required from the USER interface. The command sequences following a DMS initiation must meet specific requirements.

4.4.5 READ FORWARD A BLOCK (RDF) COMMAND

4.4.5.1 Description

The RDF command causes tape to be moved in the forward direction and the next block (only) to be read. Non-data characters of the block are detected, decoded, checked for validity, and used for their specific purposes, but not transferred across the interface. Data characters of the block are detected, decoded, checked for validity, corrected if appropriate, and transferred across the interface. Data is transferred until end-of-data is detected or until STOP is asserted by the USER interface. All characters within the block are checked for validity even if they are not all transferred. Tape motion is then halted with the read head positioned in the following interblock gap (IBG). Ending status signals reflect the validity check for the entire block.

4.4.5.2 Signal Sequence

After command initiation, the MTS moves tape in the forward direction. When a data block is detected and sufficient data characters have been decoded and deformatted, the MTS asserts a data character on the Bi-Directional Data bus (DATA), delays approximately 90 nanoseconds, and then asserts TREQ.

The USER interface must then signal transfer of the data character by asserting TRAK or STOP. Upon sensing the TRAK or STOP assertion, the MTS resets TREQ. The USER interface must then reset TRAK or STOP. Responses must meet the timing requirements of Figure 4-3.

If TRAK or STOP does not respond according to the timing requirements, an MTS internal read buffer may be overloaded. If the MTS buffer does become overloaded, data characters may be lost. Although data transfer could resume by asserting TRAK, lost data characters cannot be recovered during the in-process command operation. When data characters are lost in this type of signal sequence, CRC ERR, OVRNS, and DATA CHK are in the ending status.

Normal TREQ/TRAK responses and data character transfer continue until the USER interface signals STOP, until the MTS transfers the last byte of data, or until the MTS sets REJECT and terminates the command. When end-of-data is decoded, the MTS asserts the End of Data Pulse (ENDATP). Unless the USER TRAK timing is greater than the specified maximum, all data will have

been transferred before ENDATP is asserted. Any data not transferred by the time ENDATP is asserted is unrecoverable.

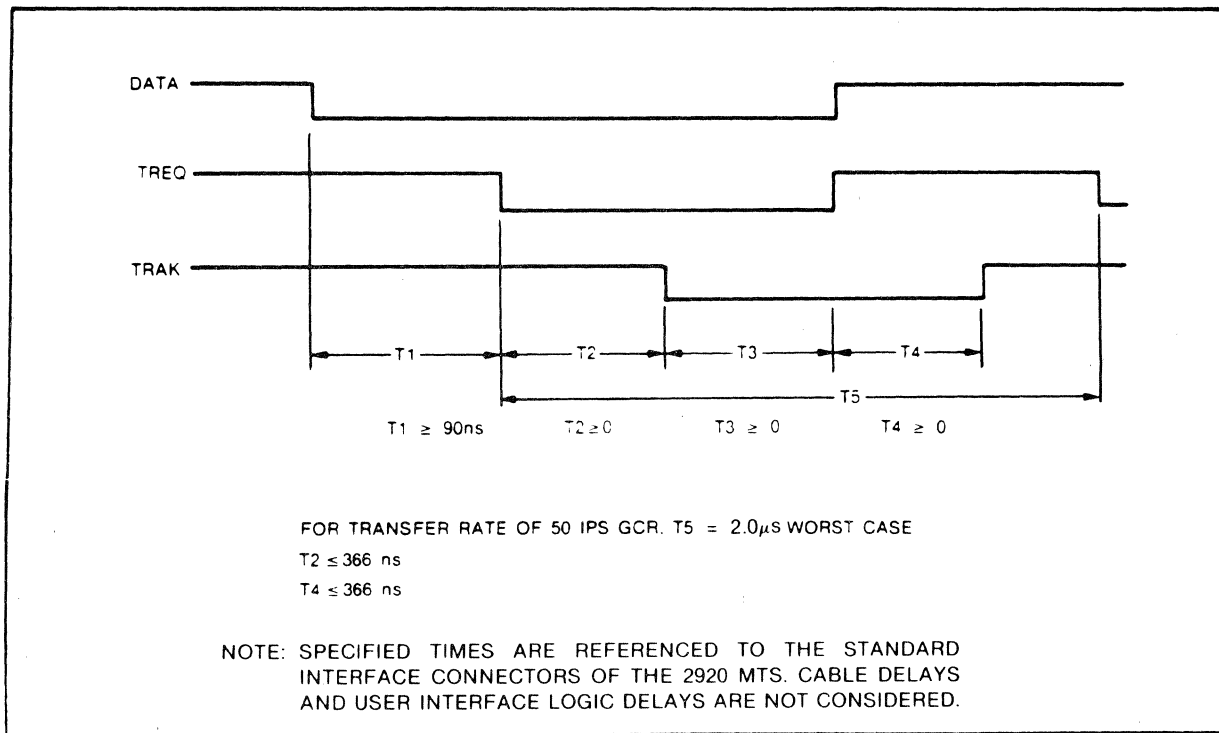

Figure 4-3. RDF or RDB Command TREQ, TRAK, and DATA Timing

The MTS then halts tape motion in the following IBG. The MTS waits for the drive to reach the IBG, asserts ending status, resets BUSY, and the command operation is completed.

4.4.5.3 RDF/BOT

When a RDF command is initiated with tape positioned at BOT, the MTS first processes the identification area (ID area) before proceeding to process the first block. The processing of the ID area is automatic within the operation, requiring no signal responses from the USER interface. In the processing, the ID area is detected and interpreted and the MTS is set to the appropriate density. The MTS asserts ID BRST during the process. The processing of the following block then occurs. If the ID area is uninterpretable, the MTS asserts the interface signals as defined in Section 4.3.7 and terminates the operation.

4.4.5.4 RDF/Tape Mark Blocks

When a RDF operation is initiated, but the next block is tape mark block, the MTS positions the read head in the following IBG, asserts Tape Mark Status (TMS), asserts BLOCK, and resets BUSY. A data block will not have been processed and no data characters will have been transferred across the interface. No signal responses will have been requested from the USER interface.

4.4.6 READ BACKWARD A BLOCK (RDB) COMMAND

4.4.6.1 Description

This operation proceeds as in Section 4.4.5.1 for RDF except that tape motion is backward and when the operation is completed the read head will be positioned in the IBG preceding (on the BOT side of) the data block.

The signal sequence is the same as described in Section 4.4.5.2 for RDF except that data is transferred in the opposite order of the RDF command.

4.4.6.2 RDB/BOT

RDB commands initiated with tape positioned at BOT are invalid commands. REJECT is asserted and the operation is terminated.

RDB commands initiated in which tape reaches the ID area without a data or tape mark block having been detected, set DATA CHK and the operation is terminated. Upon completion of this command, the tape will be positioned at BOT.

For both of the above conditions, no signal responses will have been requested from the USER interface.

4.4.6.3 RDB/Tape Mark Blocks

This situation is the same as that described in Section 4.4.5.4 except that tape motion is backward and, when the command is completed, the read head will be positioned in the IBG preceding the tape mark block.

4.4.7 WRITE A DATA BLOCK (WRT) COMMAND

4.4.7.1 Description

The WRT command causes tape to be moved in the forward direction, the ending portion of the preceding IBG to be generated, the data block to be written, the data block to be read and checked for validity, and the beginning portion of the next IBG to be generated. The data block is written in the format as determined by the Density Status lines and the Density Select switch (Sections 4.2.4 and 2.2.2.1).

Non-data characters of the data block are automatically generated, encoded, formatted, and written. Data characters to be written are transferred serially across the interface, automatically encoded, formatted, and written.

4.4.7.2 Signal Sequence

After the command initiation, the MTS first asserts RECV, signifying that the Bi-Directional Data bus (DATA) is under control of the USER interface and that the MTS will receive data transfer on DATA.

The MTS next asserts one initiating TREQ signal sequence. The USER interface must respond with assertions of data characters on DATA and by assertion of TRAK within the timing limitations of Figure 4-4. If the USER interface does not respond accordingly, the MTS resets TREQ, asserts REJECT, and terminates the command. The MTS starts tape motion. When the ending portion of the IBG has been created, the preamble is written; the USER interface must respond to TREQ by placing a data character on DATA and then asserting TRAK. The MTS acknowledges transfer of the data character by resetting TREQ. At this time the USER interface may change DATA and must reset TRAK.

Normal TREQ/TRAK/DATA response will continue until the USER interface signals STOP, signifying that the last character to be written is being transferred. The MTS then formats and writes the remainder of the block. The read-after-write checks are performed and the beginning portion of the next IBG generated. Ending status is asserted, BUSY is reset, and the operation is completed. RECV remains asserted until a command other than a WRT or LWR command is initiated.

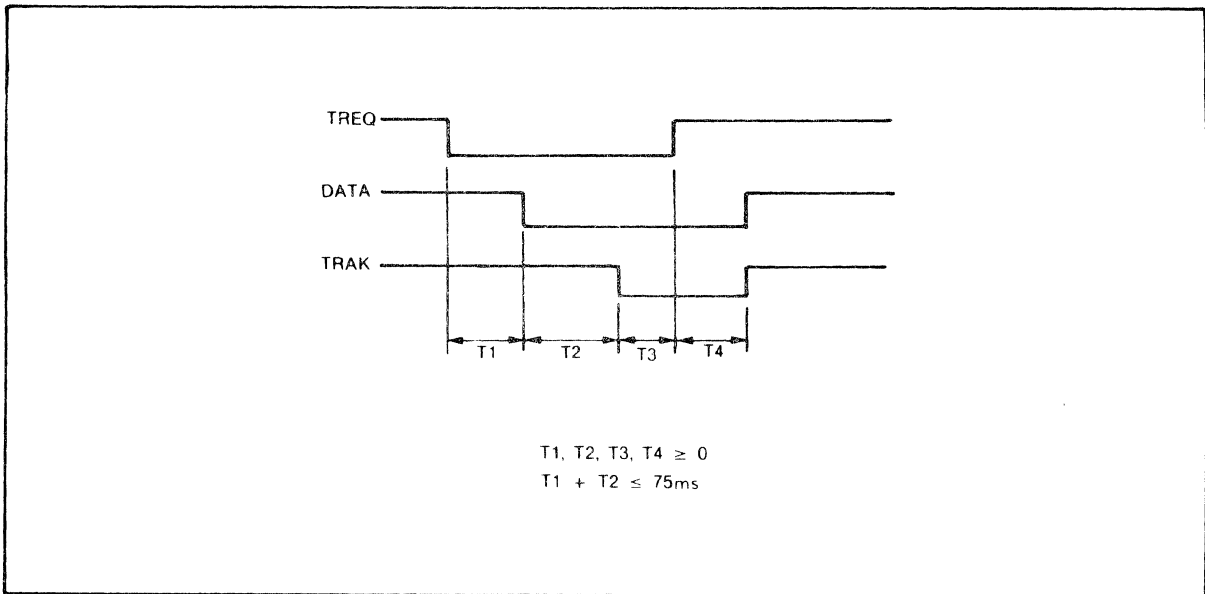

Figure 4-4. Write Commands Initiating TREQ/TRAK/DATA
(Applies to First Byte of Data)

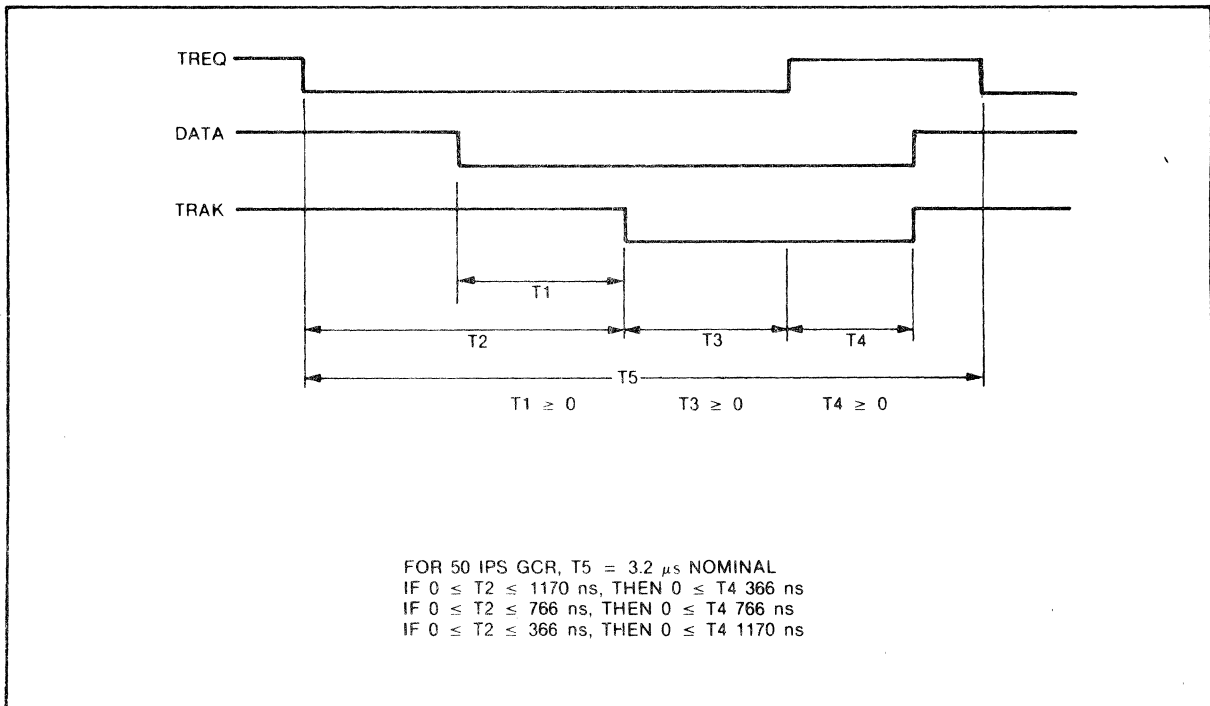

Figure 4-5. WRT Command TREQ, TRAK and DATA
(Applies to All Subsequent Bytes of Data)

These USER interface responses must meet the timing limitations in Figure 4-5. The time between consecutive TREQ signals may not be uniform. If TRAK or STOP does not respond according to the timing limitations, an internal MTS write data character buffer may be overrun. When this occurs, incorrect data encoding has occurred; the MTS discontinues requesting data, finishes formatting the block, sets Overrun Status (OVRNS), and tape motion halts.

4.4.7.3 WRT/BOT

When a WRT command is initiated with tape positioned at BOT, the MTS writes and checks the ID area before proceeding to the WRT command. The ID area is written and checked automatically within the MTS, requiring no signal responses from the USER interface.

If the ID area cannot be written and read with validity, the operation is terminated; a data block will not have been written and the WRT command will not have been performed. Appropriate ID BRST, REJECT, and DATA CHK signals are included in the ending status.

4.4.8 LOOP WRITE-TO-READ (LWR) COMMAND

The LWR command operations provide a means of testing the read and write data circuit paths within the MTS. Read signals are derived (looped) within the MTS from the write circuits. There is no tape motion.

The loop write-to-read operation may be performed only if the MTS is unloaded or loaded and at BOT.

The signal sequence is the same as that described in Section 4.4.7.2 for a WRT command operation.

4.4.9 BACKSPACE A FILE (BSF) COMMAND

4.4.9.1 Description

The BSF command causes tape to move backward, passing over data blocks encountered until a tape mark block is detected. Tape motion is halted with the read head positioned in the IBG preceding (on the BOT side of) the tape mark. Tape Mark Status is included in the ending status and the operation is completed. No data characters are checked for validity or transferred across the interface. BLOCK is not asserted for any data blocks passed over; BLOCK is asserted only at the tape mark.

Other than command initiation, no signal responses are required of the USER interface.

4.4.9.2 BSF/BOT

If the ID area is reached before finding a tape mark block, the operation is terminated. Tape will be positioned at BOT. DATA CHK and BOTS are asserted in the ending status. If BSF is initiated with tape positioned at BOT, the command is invalid, REJECT is asserted, and the operation is terminated.

4.4.10 BACKSPACE A BLOCK (BSB) COMMAND

4.4.10.1 Description

The BSB command operation causes tape to be moved backward, passing over data blocks until signaled to STOP by the USER interface. When signaled to stop, the read head will be positioned in the IBG preceding the last data block passed over. No data characters are checked for validity or transferred across the interface.

4.4.10.2 Signal Sequence

After the command initiation, the MTS begins backward tape motion. If a data block is detected, the MTS asserts BLOCK. If data block spacing is to be terminated, the USER interface must assert STOP. This assertion must occur within 2 microseconds of the assertion of BLOCK and must have a 1 microsecond minimum duration. If data block spacing is not to be terminated, STOP must not be asserted, tape motion continues, and BLOCK is reset and then reasserted when and if the next block detected is a data block. When STOP is asserted, tape motion is halted with the read head positioned in the proceeding IBG, BUSY is reset, and the operation is completed.

4.4.10.3 BSB/BOT

If BOT is reached before STOP is asserted or before a data block is detected, the operation is terminated. Tape is positioned at BOT. DATA CHK and BOTS are asserted in the ending status. If BSB is initiated with tape positioned at BOT, the command is invalid; REJECT is asserted and the operation is terminated.

4.4.10.4 BSB/Tape Mark

When a tape mark block is encountered during the operation, tape motion is halted with tape positioned in the IBG preceding the tape mark block. TMS is included in the ending status.

4.4.11 FORWARD SPACE A FILE (FSF) COMMAND

4.4.11.1 Description

This operation is the same as that described in Section 4.4.9.1 for BSF except that tape motion is forward and, at the completion of the command, the read head is positioned in the IBG following the tape mark block.

Other than initiating the command, no signal responses are required of the USER interface.

4.4.11.2 FSF/BOT

When an FSF command is initiated with tape positioned at BOT, the MTS first processes the ID area as described in Section 4.4.5.3 for RDF/BOT before proceeding to space to the next tape mark block.

4.4.12 FORWARD SPACE A BLOCK (FSB) COMMAND

4.4.12.1 Description

This operation is the same as that described in Section 4.4.10.1 for BSB except that tape motion is forward and, at the completion of the command, the read head is positioned in the IBG following the data block.

4.4.12.2 Signal Sequence

The signal sequence is the same as that described in Section 4.4.10.2 for BSB.

4.4.12.3 FSB/BOT

When a FSB command is initiated with tape positioned at BOT, the MTS first processes the ID AREA as described in Section 4.4.5.3 for RDF/BOT before commencing the FSB operation.

4.4.12.4 FSB/Tape Mark

When a tape mark block is encountered during the operation, tape motion halts with the read head positioned in the IBG following the tape mark block. TMS is included in the ending status.

4.4.13 WRITE TAPE MARK (WTM) COMMAND

4.4.13.1 Description

The WTM command causes tape to be moved forward and a tape mark block to be written and checked for validity.

If the validity check indicates that the tape mark does not meet ANSI specifications, the MTS automatically backspaces and erases forward over the written tape mark and rewrites the tape mark block. Two rewrites may be automatically attempted. If the tape mark does not meet ANSI specifications after the rewrite attempts, WTM CHK is asserted.

Other than initiating the command, no signal responses are required of the USER interface.

4.4.13.2 WTM/BOT

When a WTM command is initiated with tape positioned at BOT, the MTS first writes and checks the ID area as described in Section 4.4.7.3 for WRT/BOT before commencing the WTM operation.

4.4.14 ERASE GAP (ERG) COMMAND

4.4.14.1 Description

The ERG command causes tape to be moved in the forward direction and a 3.6 inch nominal (PE) or 3.4 inch nominal (GCR) section of tape to be erased. During the ERG operation, read checks are performed to verify that erasure has occurred. If read signals are detected, REJECT is asserted in ending status.

Other than initiating the command, no signal responses are required of the USER interface.

4.4.14.2 ERG/BOT

When an ERG command is initiated with tape positioned at BOT, the MTS first automatically causes the generation and checking of the ID area as described in Section 4.4.7.3 for WRT/BOT before commencing the ERG operation.

4.4.15 REWIND (REW) COMMAND

4.4.15.1 Description

The REW command causes tape to move in the backward direction at rewind speed. Tape motion halts with tape positioned at BOT, BUSY is asserted only until the MTS accepts the REW command. The MTS will reset Ready Status and assert Rewinding Status while performing a rewind operation and will reassert Ready Status and reset Rewinding Status when BOT is reached.

Other than initiating the command, no signal responses are required of the USER interface.

4.4.15.2 REW/BOT

No tape motion occurs and tape remains positioned at BOT. Busy is asserted only for the short time required to check that tape was positioned at BOT.

4.4.16 REWIND AND UNLOAD (RUN) COMMAND

4.4.16.1 Description

The RUN command causes tape to move in the backward direction at rewind speed. When BOT is reached, tape motion slows and tape is wound onto the file reel. BUSY is asserted only until the MTS accepts the RUN command. The MTS resets Online Status upon accepting the command.

Other than initiating the command, no signal responses are required of the USER interface.

4.4.16.2 RUN/BOT

Tape is wound completely onto the file reel. The MTS resets Online Status upon accepting the command.

4.4.17 SENSE DRIVE STATUS (SNS) COMMAND

4.4.17.1 Description

This command initiates the transfer of the various drive status bytes (DSBs) across the Error Multiplex Bus to the USER. Upon receiving a SNS command, the MTS places the next DSB on the interface. This DSB remains valid until the MTS is issued a NOP command. At this point the MTS may be issued a CLR command to place DSB0 on the Error Multiplex Bus and return the MTS to the idle mode or the MTS may be issued a SNS command to request the next sequential DSB.

4.4.17.2 Signal Sequence

Each SNS must be followed by a NOP command which in turn must be followed by SNS or a CLR command. The assertion of the RESET line at any time during this sequence will place DSB0 on the Error Multiplex Bus and return the MTS to the idle mode.

CHAPTER 5
FUNCTIONAL DESCRIPTION

5.1 INTRODUCTION

This chapter provides brief functional descriptions of the circuit cards of the MTS. Although the circuit cards are not repairable in the field, a basic knowledge of the functions of each card may be useful for troubleshooting and repair of the MTS. Refer to Figure 5-1 for a general block diagram of the MTS circuit cards.

5.2 INTERFACE/MICROPROCESSOR (IF CARD)

All functions of the MTS are controlled by the IF interface/microprocessor card (Figure 5-2). The microprocessor responds to commands from the operator panel and the USER, generates control signals for the capstan and reel servo systems, monitors the interlock and fault detection circuits, and provides status information to the operator panel and to the USER.

The memory is comprised of three EPROMs plugged into sockets. These provide 16K of functional code and 8K of diagnostic routine. Two static RAM chips provide 4K of RAM for functional and diagnostic code storage. The diagnostic RAM can be shut off from the Z80 and used as a source and receiver of "Simulated Data" to provide the ability to run diagnostics in a standalone mode. All Z80 controls and status are sent to and from other circuit cards (DP, WR, SV, and KK) through the Z80 bus.

The oscillator provides a 5 MHz output for the Z80 microprocessor and a 2.5 MHz clock with a 25% duty cycle as master and slave clocks for the LSI chips. Power Up Reset clears all TTL status and starts the Z80 at instruction 0000. A Watchdog Timer is generated as a check on the code for the Z80. The Z80 retriggers the Watchdog Timer once every 10 milliseconds, otherwise a non-maskable interrupt occurs which causes the Z80 to EPO, turning off all servo controls and reinitializing the MTS.

5.3 WRITE DATA PATH (DP CARD)

The write data path of the DP data path card (Figure 5-3) is comprised of two CMOS LSI chips (XWC and XWD) and receives its data from a third dual-purpose LSI chip (XBR). XBR is used in both read and write modes and is used during write operation as a 7-byte FIFO to interface between the IF card and XWC.

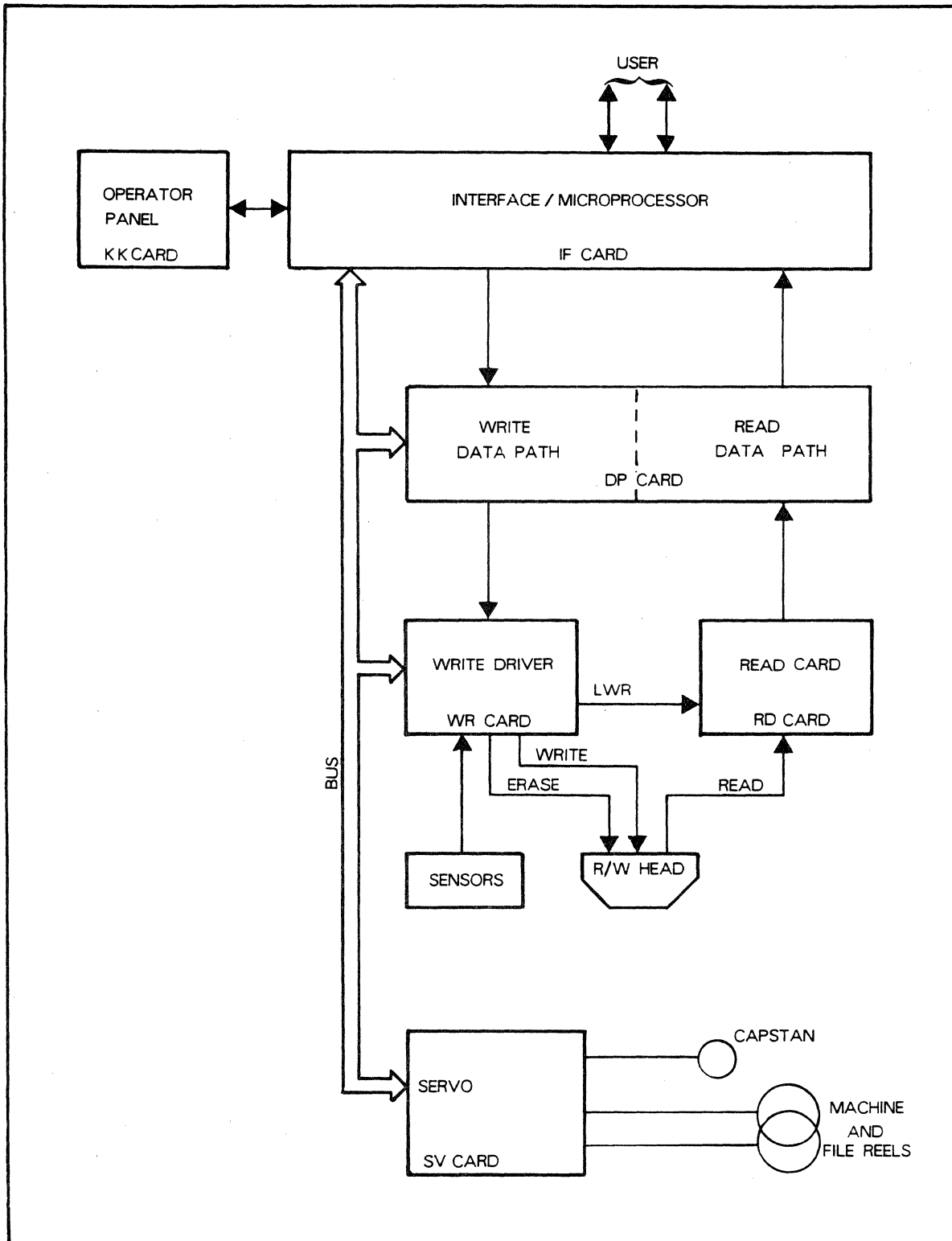

Figure 5-1. MTS Block Diagram

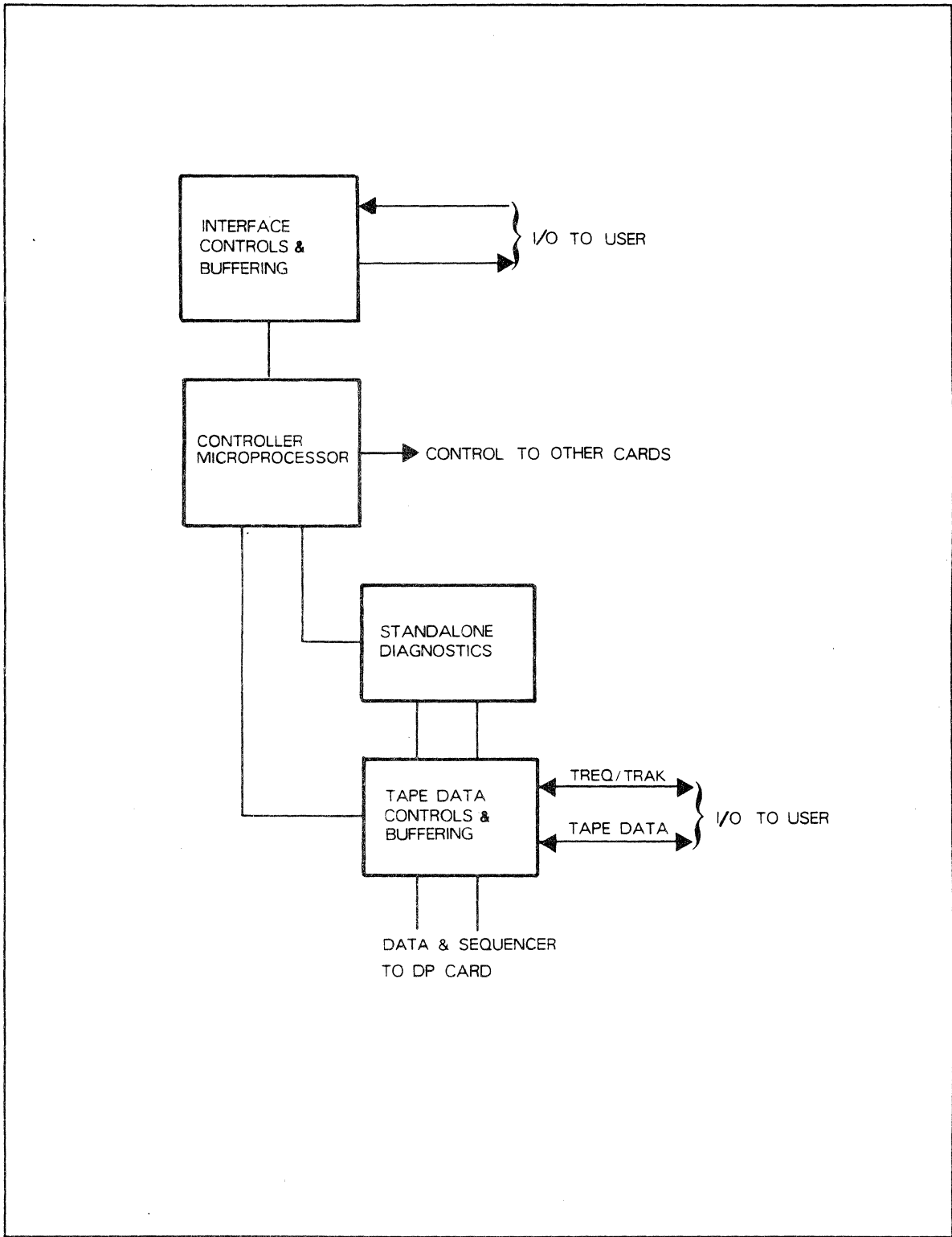

Figure 5-2. Interface/Microprocessor Block Diagram (IF Card)

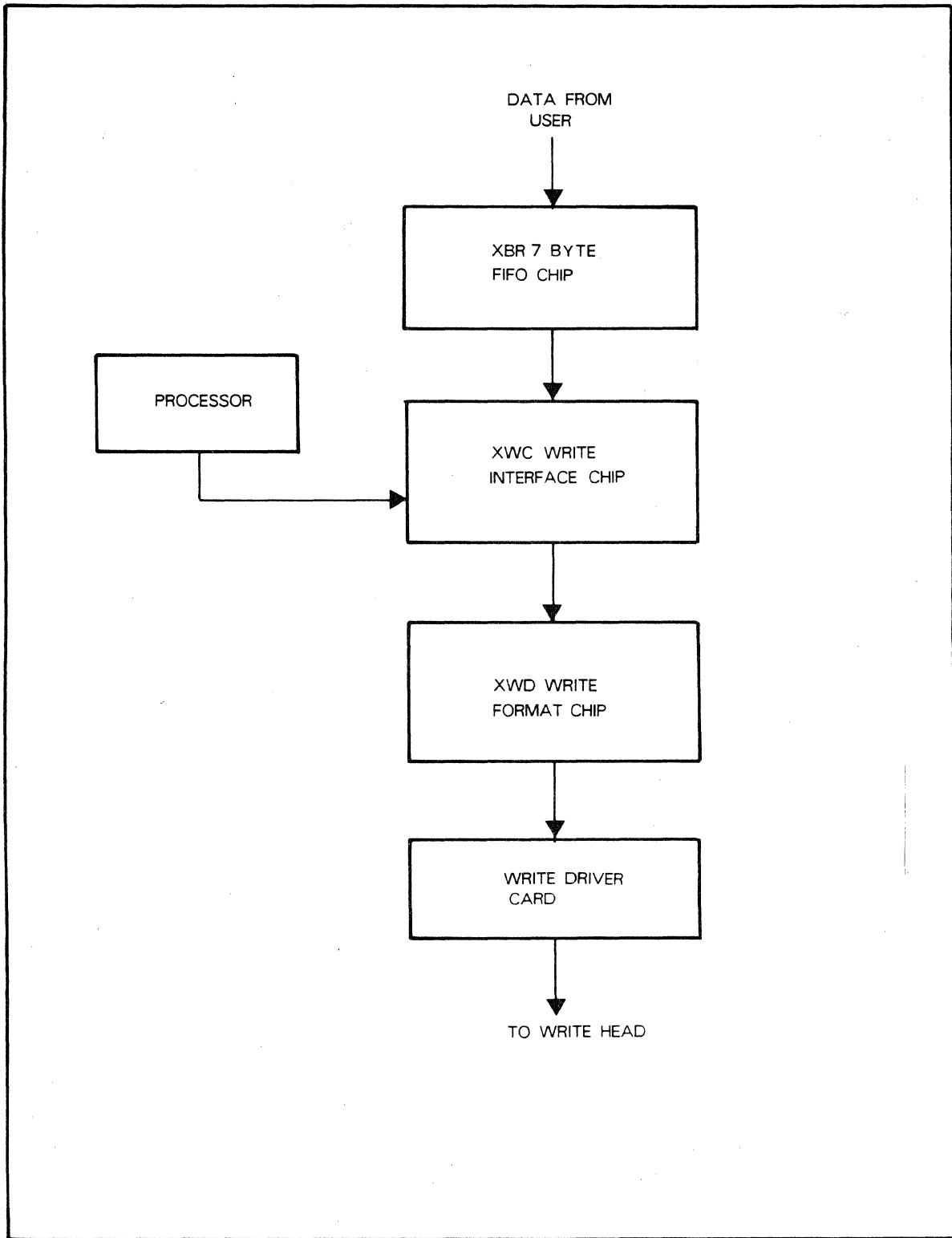

Figure 5-3. Write Path Block Diagram (DP Card)

Data is input to XBR via TREQ/TRAK handshaking sequences. Once XBR has data ready to be written, it signals XWC by raising Data Available. XWC accepts the data when needed and, upon taking the data, sends XBR a Write Strobe to indicate that the data byte has been accepted. This process continues until the interface raises STOP and XBR signals XWC that the last byte has been taken. Once the data has entered into XWC, check characters are generated for the data and it is clocked into XWD. The data is clocked out of XWD as write triggers.

XWC controls the overall format of data records which are to be written to tape. These records may be written in either PE format (1600 bpi density) or GCR format (6250 bpi density). XWC takes data from an interface data buffer, generates check characters for the data, and strobes the data into XWD.

When writing GCR format records, data bytes are processed in groups of four with the four data bytes being input, strobed into the check character generators, and output to the XWD. When writing PE format records, data bytes are processed one at a time with a data byte being loaded from the interface and then output to XWD.

Four Command lines and one Density Select line are used to control the operation of XWC:

C3	C2	C1	C0	
1	0	0	1	Write Data Record
1	0	1	0	Write ID
1	0	1	1	Write ARA Burst
1	1	0	0	Write ARA ID
1	1	1	1	Write Tape Mark

XWD inputs data from XWC and, in the case of GCR format, performs a 4-to-5 conversion on the data and outputs the data in the form of write triggers. In PE format, data is input from XWC and transformed into two write triggers (Data and Phase).

5.4 WRITE DRIVERS (WR CARD)

The basic write circuits are located on the WR write driver card (Figure 5-4). Erase and write functions are controlled by enables from the IF card. The logic establishes the proper head current for the specific density to be recorded and current sensing on each of the nine tracks is used to verify that write currents are of proper magnitude for the density. Hardware failures resulting in incorrect write or erase current produce a hardware interrupt which immediately stops the tape drive.

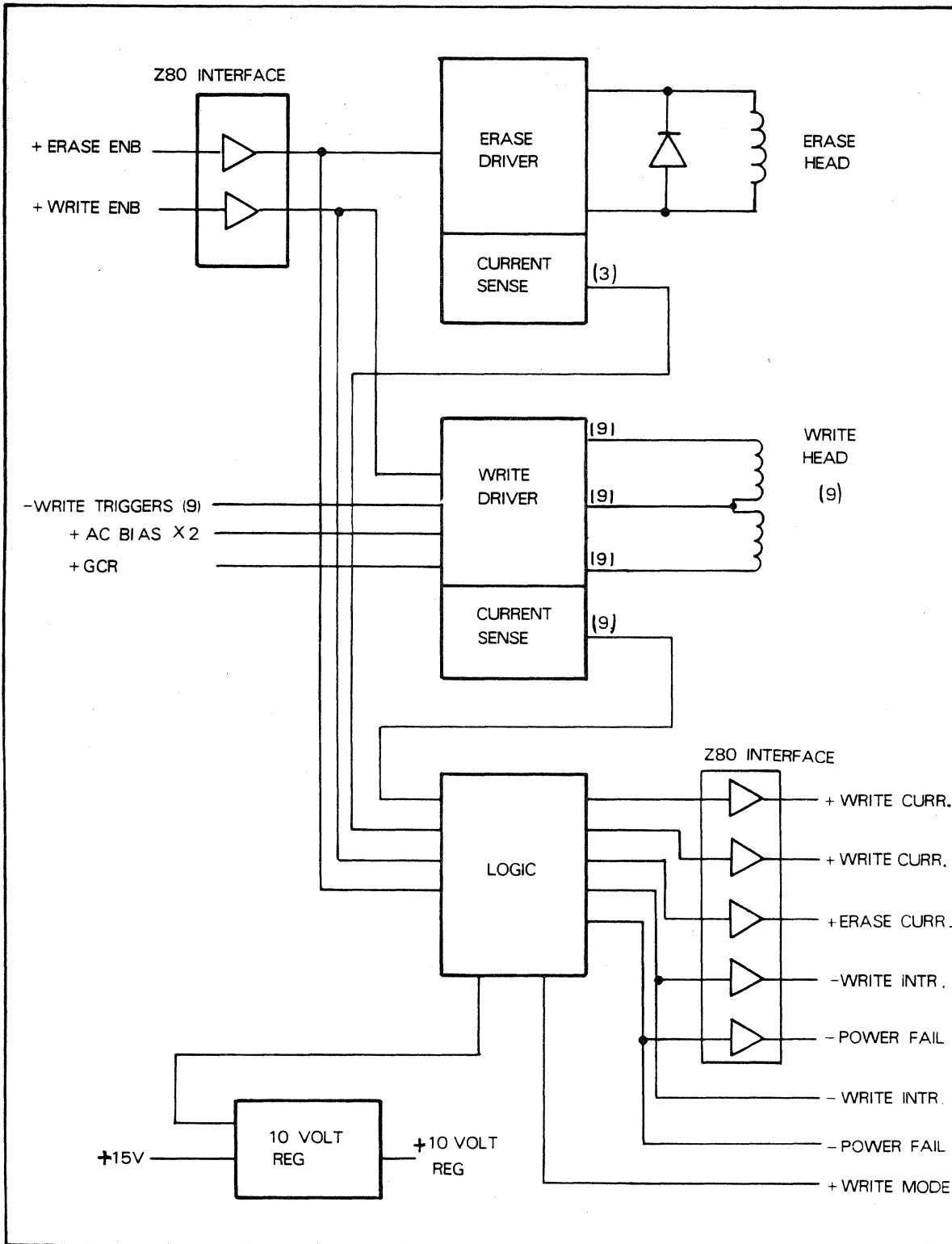

Figure 5-4. Write Driver Block Diagram (WR Card)

The WR card is also used for machine sensor circuits. The sensor circuits are used to detect tape present, BOT, EOT, the tape leader as it passes the entrance to the thread path, and the write enable ring (file protect). The machine reel and file reel index channels and the swing arms extended switch sensors are included on the card.

5.5 READ (RD CARD)

Each of the nine differential analog signals from the read head is amplified, filtered, and differentiated by the analog signal processing circuits on the RD read card (Figure 5-5). The resulting nine analog read signals at the bandpass filter output (+Dif Analog) are available at test points on the card before they are converted to digital read data by the limiter. The nominal single-ended analog signal amplitude, measured peak-to-valley at the test point, is 1.2 volts.

The analog signal at the bandpass filter output is monitored for amplitude integrity by the amp sensor. The analog signal zero-to-peak amplitude is compared to a threshold voltage level: either a fixed DC level, which represents the minimum acceptable worst-case analog amplitude; or an adaptive DC level, which represents a fixed percentage of the zero-to-peak analog amplitude. Whichever threshold voltage is higher at any instant in time will be the amp sensor threshold level. The threshold level is controlled by -Record Latch (-RL), +Write Mode (+WR), and +Write Triggers Active (+WTA). When the analog signal zero-to-peak amplitude is above the threshold level, the amp sense output switches to a high TTL level; when the analog signal level drops below the threshold level, the amp sense output switches to a low TTL level.

The loop write-to-read (LWR) multiplexer selects either Read Data from the limiter in normal operation or Write Triggers from the DP card in test mode.

Three CMOS LSI chips, each containing three tracks of logic, detect the phase of the data passed through the LWR multiplexer. This phase information is used in the phase-locked loop (PLL) to correct the frequency of the voltage-controlled oscillator (VCO). The VCO output, in turn, clocks the LSI chips at the proper rate in order to track tape velocity. The chips also convert the data from GCR format (6250 bpi density) or PE format (1600 bpi density) to NRZ (non-return-to-zero) format. NRZ data and clocks for each track are output to the DP card.

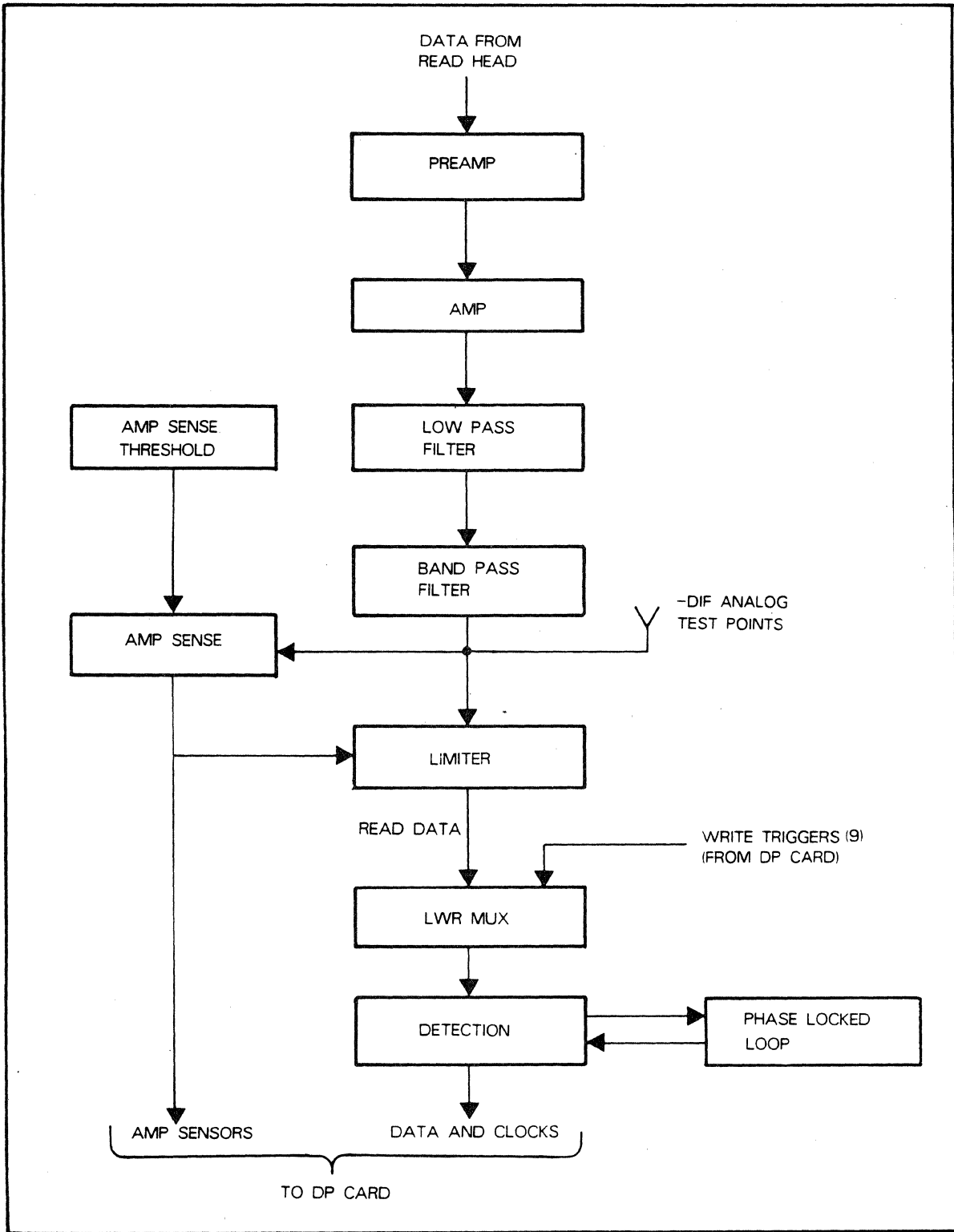

Figure 5-5. Read Block Diagram (RD Card)

5.6 READ DATA PATH (DP CARD)

The read data path of the DP card (Figure 5-6) receives its data input from the RD read card. The data is processed on the DP card and output via TREQ/TRAK handshaking sequences to the interface.

5.6.1 PE OPERATION

PE (1600 bpi density) is handled in 5-byte groups. Data is fed into the XRB skew buffer from the digital detection circuit on the RD read card. Each track sets Track Ready when it has these five bytes available. All Track Ready signals feed XCR. With all tracks ready, a Load Group Buffer pulse occurs followed by four Shift Group Buffer pulses. These five pulses transfer the five bytes from XRB to XEC and XBE. The data is actually stored only in XBE while XEC inputs each byte into the error correction system. After the fourth Shift Group Buffer, XEC sets ECC Full, preventing more transfers from XRB.

No correction cycle is required as correction is done on-the-fly; therefore, a Shift Out Mode is immediately initiated. During Shift Out Mode, data in XBE is transferred into the XBR data buffer with XEC supplying the proper correction. After the Shift Out Mode, ECC Full is reset and XRB can supply another 5-byte group to the XEC and XBE.

XBR now contains five bytes of corrected data, ready to be transferred to the interface; however, because of the method of PE end-of-data detection, XBR inhibits data transfer until it sees that ECC Full is set again. This is done so that a look-ahead function can be performed for determining PE end-of-data. This function checks the next group (the one in the XBE buffer) for four bytes of all-ZEROs. If the ending all-ONES byte of PE data is present on the output of XBR and the following four bytes are all-ZEROs, PE end-of-data is declared and the read process is stopped.

With XBR Buffer Full and ECC Full set, the interface data transfer is started via TREQ/TRAK handshake sequences. The XBR buffer will now be empty, allowing XEC to transfer another group out of the XBE buffer and into the XBR buffer. End of Data is set by XBR immediately after the last byte of data has been transferred to the interface.

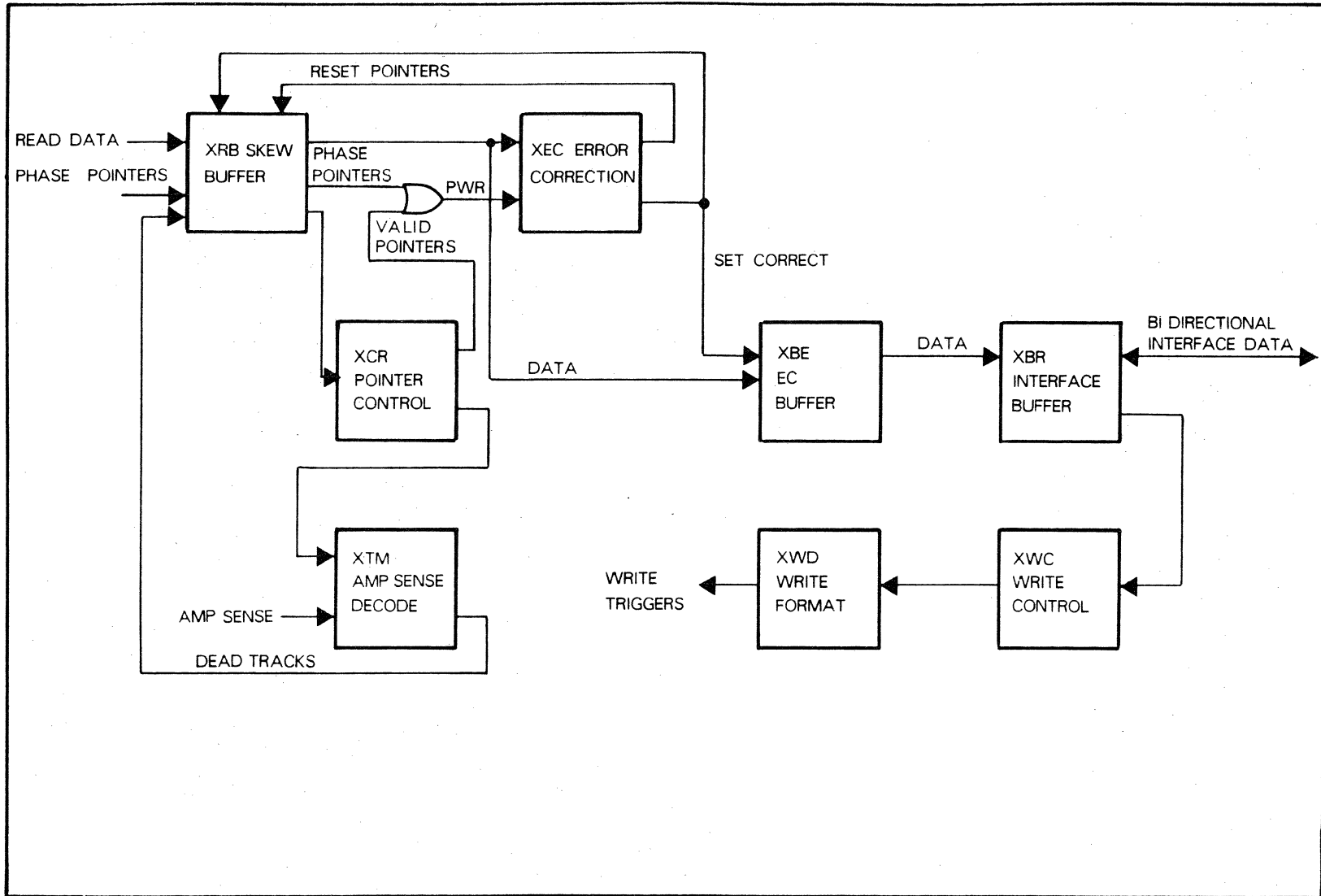

Figure 5-6. Read Path Block Diagram (DP Card)

5.6.2 GCR OPERATION

Handling of GCR (6250 bpi density) data differs slightly from that of PE. The major difference is that GCR data is handled in 8-byte groups. XRB assembles a 4-byte subgroup and sets Track Ready. These four bytes are then transferred to XEC and XBE with the four Shift Group Buffer pulses. The Load Group Buffer signal does occur but data is not transferred with it; it is used by XEC to initialize registers between groups and by XBE to count groups. The next 4-byte subgroup is transferred from XRB and then ECC Full is set. XEC handles inputting of data to XBE by propagating Shift Group Buffer pulses. The ECC byte present in each 8-byte group is stripped from the group by XEC by blocking the last Shift Group Buffer (first Shift Group Buffer when reading backward) to XBE.

XEC now determines if a correction cycle is necessary and, if not, Shift Out Mode begins immediately. If correction is required, Shift Out Mode will be delayed by as much as 2.8 microseconds, the maximum duration of a correction cycle. Shift Out Mode is set for seven cycles (2.8 microseconds) during which time the seven bytes in XBE are transferred to the XBR data buffer while being corrected. XBR does not need to wait for another ECC Full to transfer data, so it will do seven transfers to the interface. The Shift Out Mode which filled the XBR buffer causes XBR Buffer Full to set and also causes ECC Full to reset. While XBR is transferring data to the interface, XRB may start filling XEC and XBE again. XEC may not do another Shift Out Mode until XBR has completed the seven transfers at which time it will reset XBR Buffer Full.

XBE determines the presence of the GCR format groups based on information supplied by XRB and XCR. XCR determines when End Mark is in XRB by looking at Sync Mark and Format signals from XRB. When End Mark is in XRB, XCR issues a Load Group Buffer pulse without any Shift Group Buffer pulses. End Mark is not loaded into XEC and XBE. In read forward, the next group is the Residual Group which is transferred from XBE to XBR while the Residual Group signal is on. This causes XBR to hold the Residual Group until the following CRC Group can be received and the residual byte of the CRC Group can be determined. The residual byte informs XBR how many bytes in the residual group are data and which are pads. At this time the last data transfers of the record occur and End of Data is set.

In GCR backward operations, the CRC and residual groups must be handled first and then operate as in forward read operations. The CRC Group comes into the XBR buffer first. The residual character is saved and the buffer waits for the residual group to be loaded. When it is in XBR, it determines the number of valid data

bytes in the group and transfers them to the interface. The rest of the record is then processed normally. XBR does not do End of Data detection in GCR for read backward; XBE performs this function by sensing that the Mark 1 character has been detected and the appropriate number of ONEs in the preamble have been checked. End of Data is set after the last data byte has transferred.

5.7 SERVO SYSTEM (SV CARD)

The SV servo card contains the analog and digital circuits which comprise the capstan servo system, the two reel servo systems, the swing-arm retraction motor control, the emergency power-off (EPO) logic and relay control, and the servo power failure detector.

The SV card interfaces to the system microprocessor (which resides on the IF card); to the optical encoders which are the servo transducers for the capstan motor and the swing-arms; to the capstan, reel, and arm retraction motors; to the EPO relay; and to the power supply. All of the interfaces are via connectors on the motherboard.

The capstan servo system (Figure 5-7) consists of a CMOS LSI controller which operates in conjunction with the system microprocessor. This LSI circuit generates digital commands which are converted to an analog voltage via a digital-to-analog converter (DAC). A linear power amplifier converts this voltage to motor drive current.

The reel servo system (Figure 5-8) consists of a CMOS LSI controller which operates in conjunction with the microprocessor. Digital commands to a set of twin DACs and pulse-width modulated power amplifiers generate the currents for the two reel motors.

The swing-arm retraction motor control is a bipolar power switch which operates under logical control of the microprocessor together with the reel servo controller chip.

The EPO relay control consists of logic in the reel servo controller chip which generates the logical function that controls a regulated relay driver.

The power failure detector is a set of voltage comparator circuits which monitor the $\pm 26/36$ volt and ± 15 volt power supplies for undervoltage. This circuit generates a logic signal which is one of the elements of the EPO control.

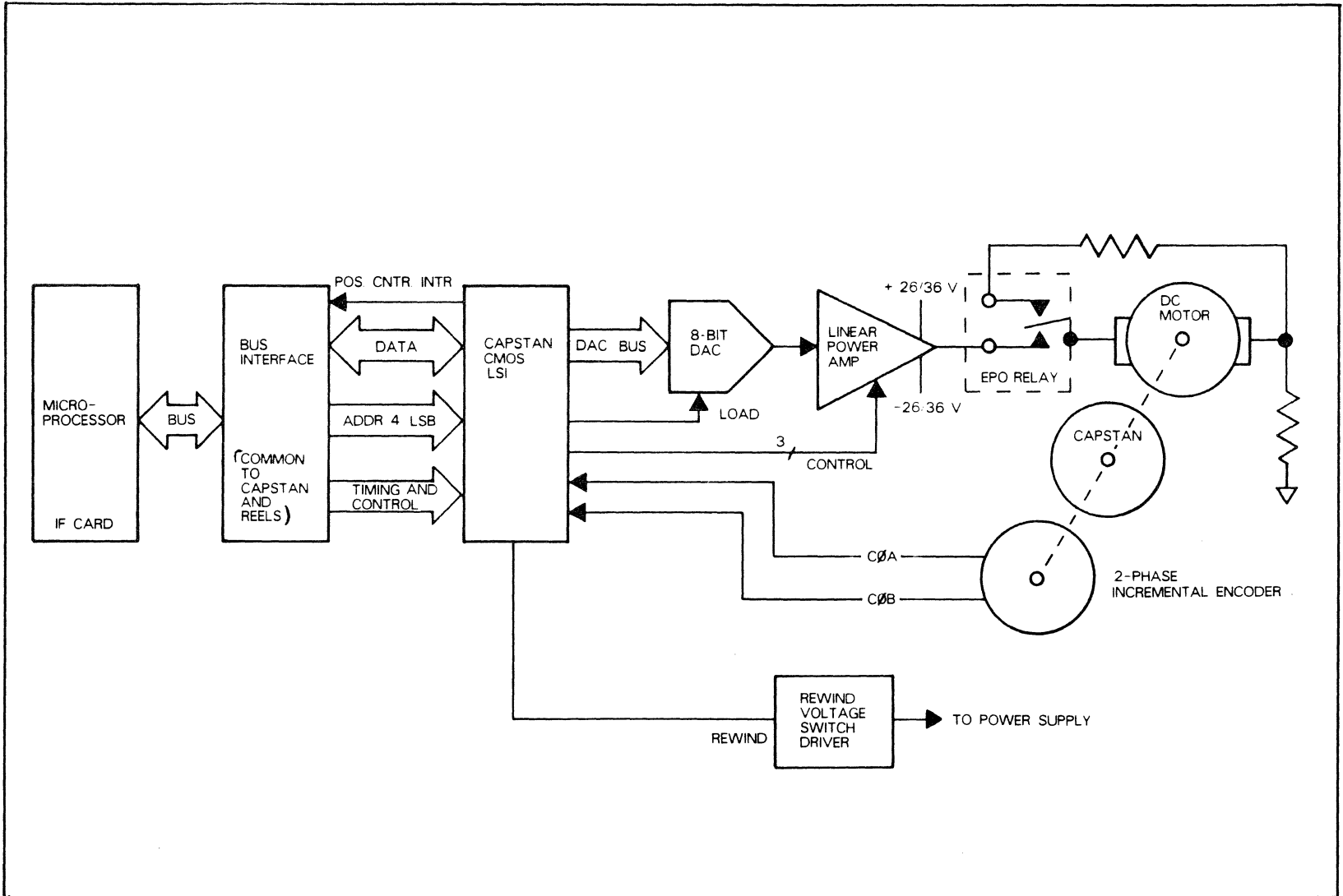

Figure 5-7. Capstan Servo System Block Diagram

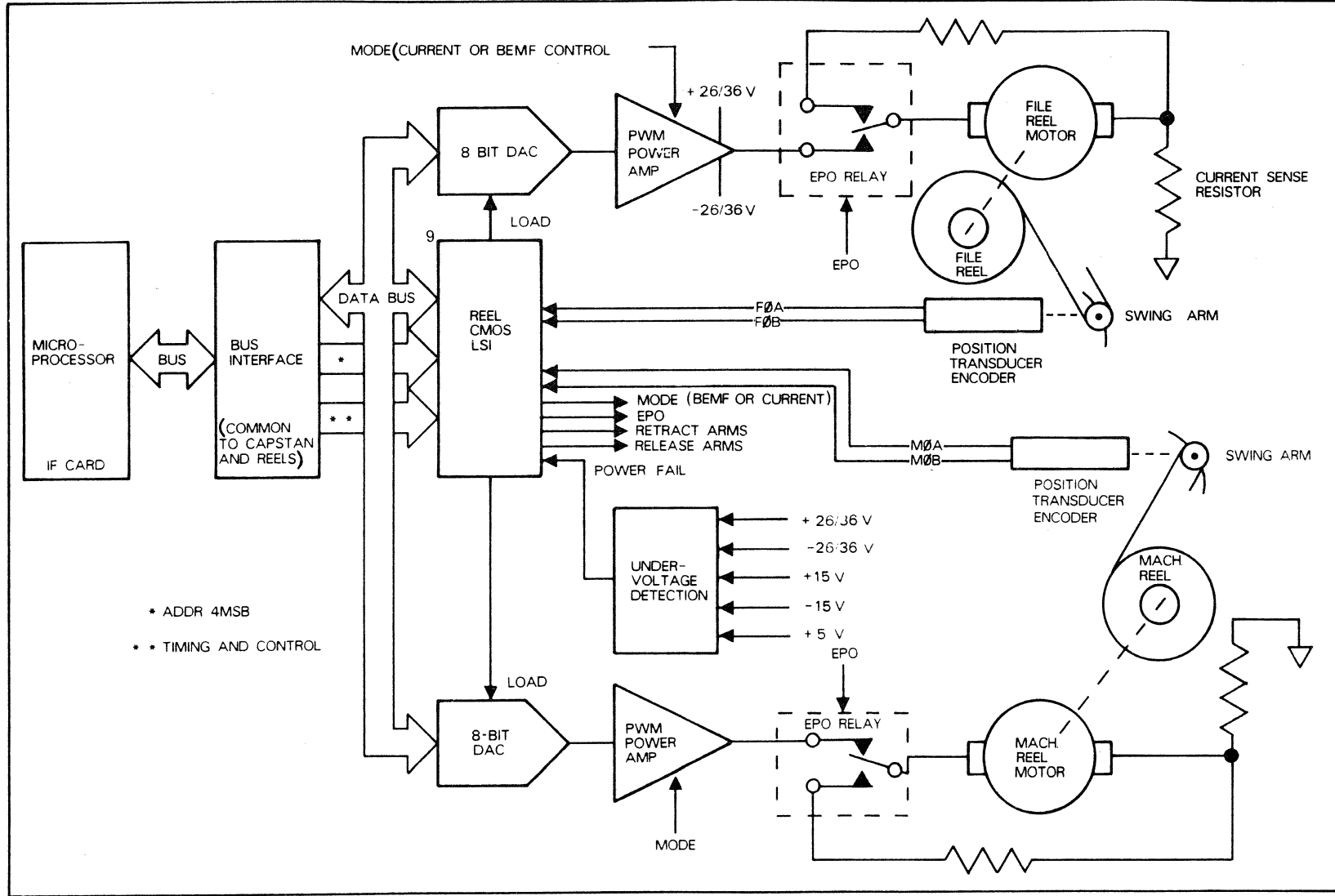

Figure 5-8. Reel Servo System Block Diagram

5.8 POWER SYSTEM

The power system is comprised of the main circuit breaker, the Power On/Off switch on the operator panel, a line filter, transformer, AK regulator card, PK protection card, and NK regulator card. Refer to Figure 5-9 for a simplified block diagram of the power system.

The power system provides logic voltages for the electronics and power voltages for the capstan and reel motor drives as well as the vacuum blower motor. In addition, 120 Vac is provided for the the cooling fan.

Overcurrent protection is provided by the PK protection card which will trip the main circuit breaker remotely if any power system output is shorted. A short on the primary will also trip the main circuit breaker. If an overvoltage of 5.7 volts (or higher) occurs on the +5 Vdc output, fuse F2 on the AK regulator card will open.

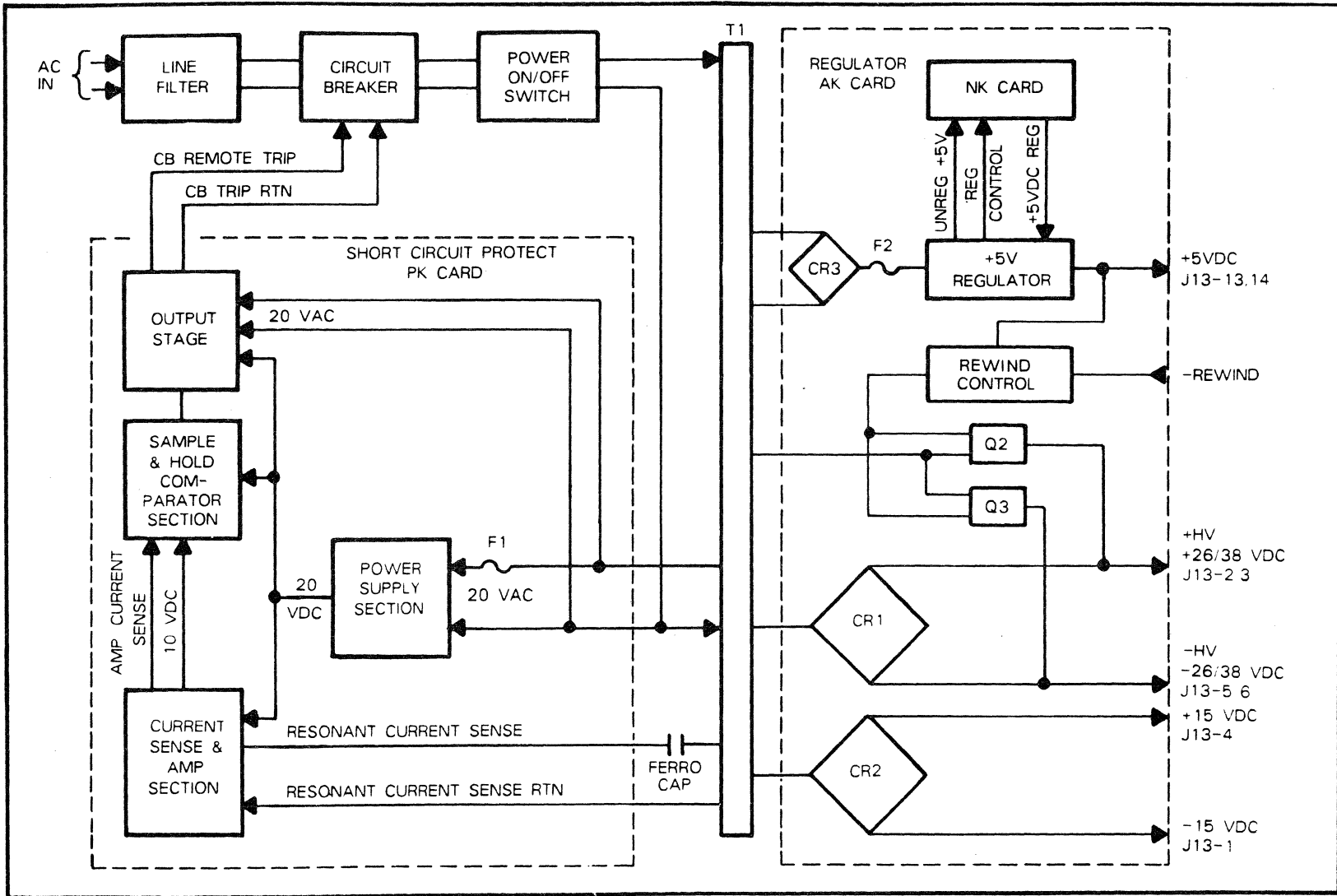

Figure 5-9. Power System Block Diagram

CHAPTER 6
MAINTENANCE

6.1 INTRODUCTION

This chapter provides instructions for the performance of maintenance procedures. These procedures are to be performed quarterly to ensure proper operation and at such times the MTS does not perform according to specifications. Should there be a defective part, Chapter 7 provides instructions for changing field replaceable parts. Operating procedures for maintenance programs are described in Section 8.2.

6.2 PREVENTIVE MAINTENANCE

The following is a checklist of the routine preventive maintenance to be performed quarterly by trained personnel.

1. With power off, check the file reel hub for free operation. Thoroughly clean as necessary.
2. Remove the tape cleaner block. (Refer to Section 7.2.2 for removal procedures.) Thoroughly clean the block with Hub and Transport Cleaner Fluid. Inspect the cleaner block for damage in the form of scratches or grooves in the cleaner surface and replace the block if it is damaged.
3. With power on, check that the cooling fans are operating.
4. Check the power supply output levels. (Refer to Section 6.3.)
5. Check the file protect mechanism for proper operation using a work tape both with and without a write enable ring installed.
6. Check rewind for proper operation. Check rewind time (2.5 minutes for 2400 feet of tape).
7. Inspect the tape in the tape path for proper tracking. (Refer to Section 6.4.1 for detailed procedure.)
8. Check the read/write head for proper alignment and adjust skew as necessary. (Refer to Section 6.4.2 and 6.4.3.)
9. Check read output amplitudes. (Refer to Section 6.5.)
10. Run all diagnostics.

6.3 POWER SUPPLY CHECK

The power supply output voltage levels should be checked with the input AC power voltage level at nominal. Tape may be loaded but should not be in motion (except during a rewind operation in order to check the ± 36 volts).

All test points indicated are pins on the motherboard at slot A1. (Note that the voltage and ground pins are not identical from slot to slot.) Use pin B01 at slot A3 for ground.

Test Point	Voltage
A01	+5.1 (± 0.25) Maximum ripple: 100 mV P-P
C03	+15 (+1.0, -1.5)
C01	-15 (+1.0, -1.5)
C05	+26 (± 4.0)
C17	-26 (± 4.0)
C05	+36 (32-45) In rewind only
C17	-36 (32-45) In rewind only

6.4 TAPE TRACKING AND SKEW

An understanding of tape tracking and skew requirements is helpful in the performance of the capstan alignment (tape tracking) and read/write head alignment (skew) procedures: Alignment of the capstan to the tape path assures that the tape does not take an angular path across the read/write head. Alignment of the read/write head assures that the head is properly aligned with the tape.

The tape tracking adjustments are first made visually to set coarse alignment. A skew tape and oscilloscope are then used for the final alignment to detect static and dynamic skew variations. Static skew, as shown in Figure 6-1, is the time from the peak of the bit used for the scope sync to the peak of any other bit. Dynamic skew, also shown in Figure 6-1, is the width of the variation or flutter of the bit not used as the scope sync. The two outside tracks are used to check final alignment. Tape tracking and skew checks should be performed when any of the following components are replaced:

- Upper Swing Arm
- Lower Swing Arm
- Capstan
- Capstan Motor
- Read/Write Head
- Upper Tape Guide

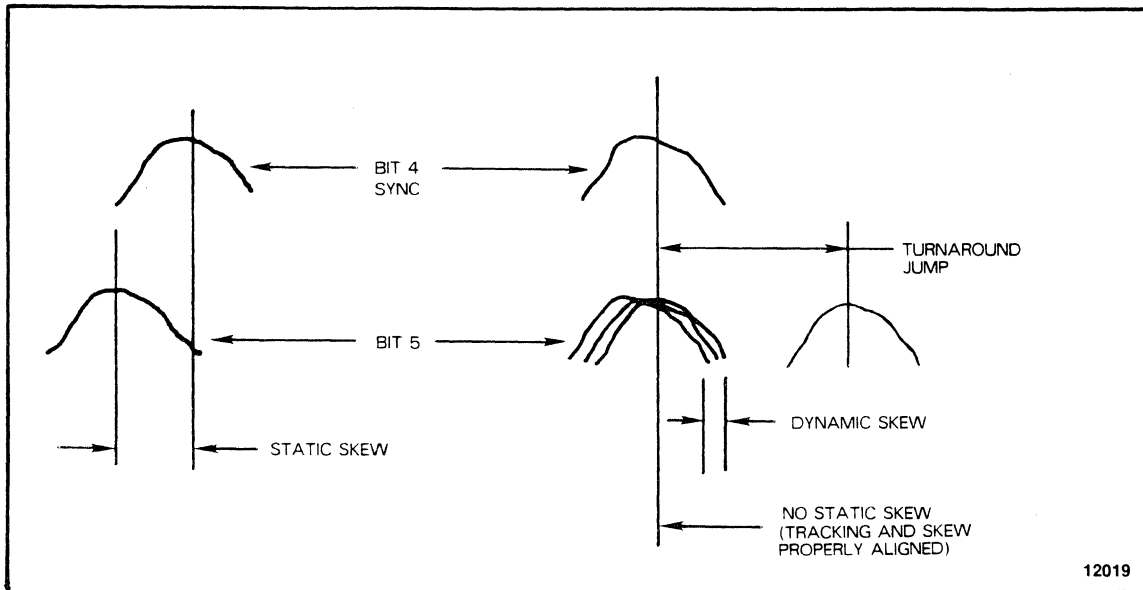

Figure 6-1. Static and Dynamic Skew and Turnaround Jump

6.4.1 CAPSTAN ALIGNMENT (TAPE TRACKING)

1. Open the threading cover and remove the outer flange from the upper tape guide.
2. Close the threading cover, mount and load a work tape, then open the threading cover to provide access for checks and adjustments.
3. Enter maintenance program 00 to move tape forward. Check that tape is flush with (but not forced against) the rear flange of the upper guide and is not riding over the front of the upper guide. If necessary, adjust capstan motor mounting screw 3. Refer to Table 6-1 and Figure 6-2.
4. Enter maintenance program 02 to perform the shoeshine routine (forward/backward tape motion). Check that tape is not overhanging either the front or rear edge of the capstan.

- Adjust tracking such that the tape travels in the same position on the capstan in both forward and backward directions. Ignore at this time any tape jump which may be present just as the capstan changes direction; do not attempt to adjust out the jump.

Table 6-1. Capstan Alignment

CONDITION	ADJUSTMENT
Tape tracks to front edge in both forward and backward	Turn screw 3 CW
Tape tracks to back edge in both forward and backward	Turn screw 3 CCW
Tape tracks to back in forward and tracks to front in backward	Turn screw 1 CW or turn screw 2 CCW
Tape tracks to front in forward and tracks to back in backward	Turn screw 1 CCW or turn screw 2 CW

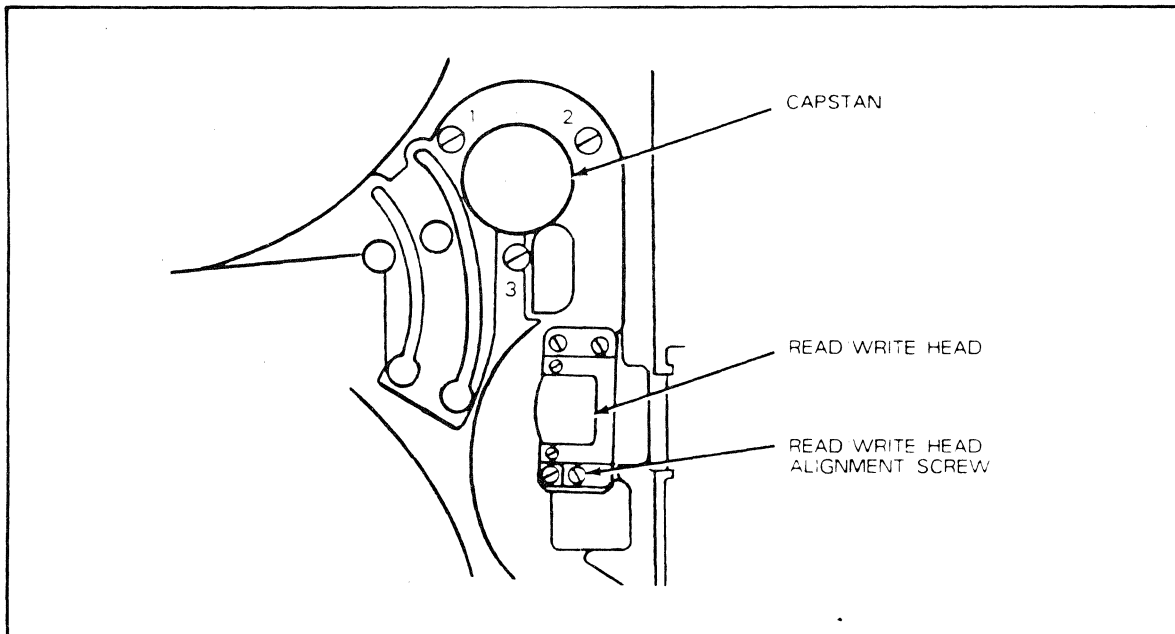

Figure 6-2. Capstan and Read/Write Head Alignment

6. Recheck tape position in the upper tape guide. If necessary, adjust motor mounting screw 3 as in step 3.
7. Unload and remove the work tape and reinstall the outer flange of the upper tape guide.

6.4.2 SKEW ADJUSTMENT

1. With power off, remove the card cage cover and disconnect the write head cable from the front of the WR card (slot A4).
2. With power on, mount and load a master alignment tape without a write enable ring. Ensure the File Protect indicator is illuminated at the completion of the load. (Never high speed rewind a master alignment tape.)
3. Connect a dual-trace oscilloscope channel 1 to bit 5 (TP 5) on the RD card (slot A6) and channel 2 to bit 7 (TP 7). The scope settings should be as follows:

Sweep	5 and 2 microseconds/division
Trigger	Negative Slope Channel 1 Only Internal HF Reject Normal
Mode	Chopped
Channel 1	100 millivolts/division
Channel 2	100 millivolts/division

4. Enter maintenance program 00 to move tape forward. Adjust the read/write head alignment screw (Figure 6-2) until forward skew is less than 1 microsecond and as close as possible to 0.
5. Move scope channel 2 up to bit 3 (TP 3) (refer to Figure 6-3). (A shift in phase or a loss of display on scope channel 2 indicates that the read/write head skew is out by one byte or more.) Adjust the alignment screw to align bits 5 and 3. Move channel 2 up one test point to the next bit and checking alignment. If the bit is not aligned, again adjust the alignment screw. Continue until all bits have been checked and aligned.

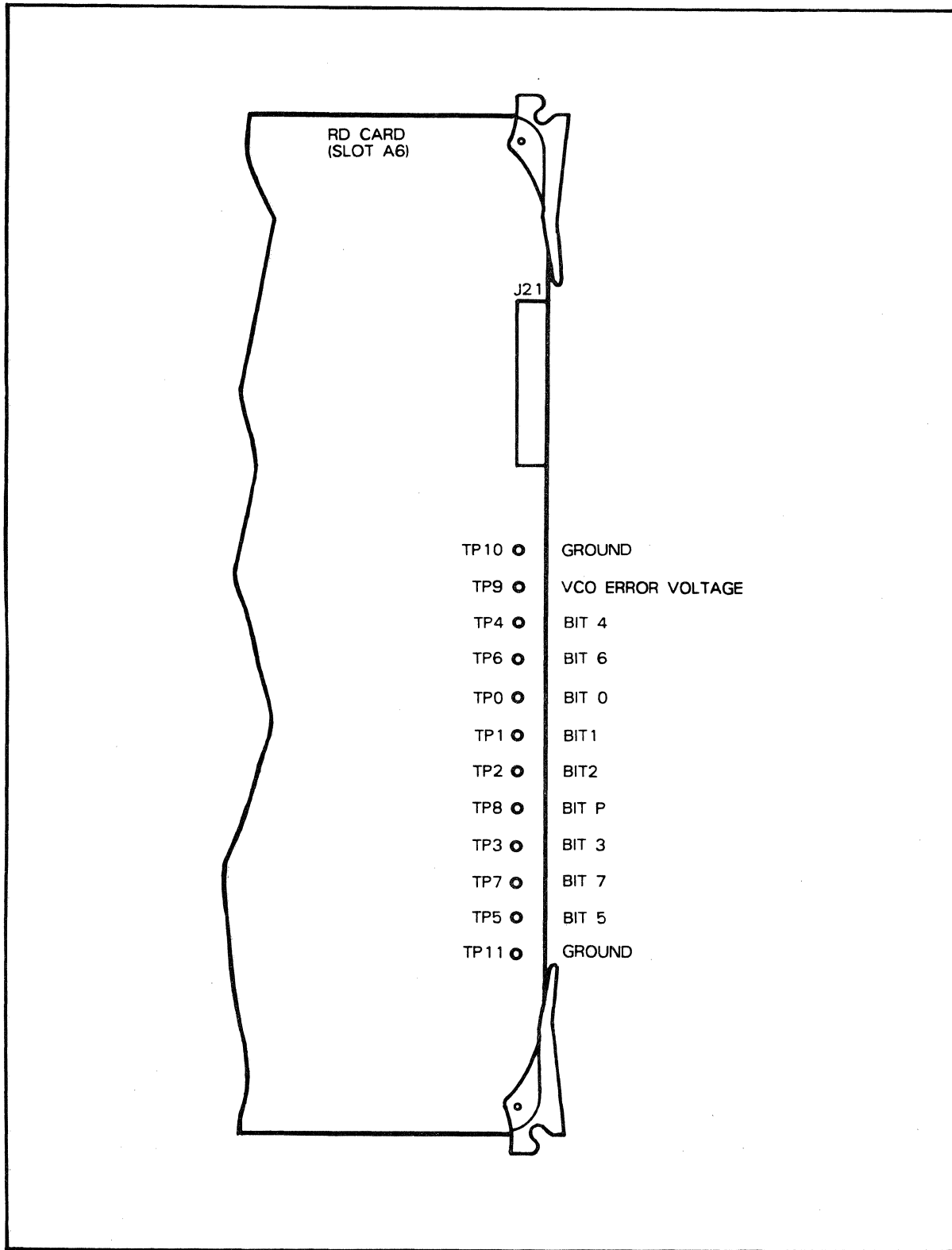

Figure 6-3. +Dif Analog Test Points

6. Enter maintenance program 01 to move tape backward. With scope channel 1 still on bit 5 (TP 5) and channel 2 on bit 4 (TP 4), adjust capstan motor mounting screw 1 or 2 very slightly until backward static skew is less than 1 microsecond and as close as possible to 0.
7. Enter maintenance program 00 to move tape forward. Check that forward static skew is still less than 1 and close to 0. If necessary, readjust the read/write head alignment screw. (It may be necessary to perform steps 6 and 7 three or four times to ensure that forward and backward skew are negligible.)
8. Examine closely the upper tape guide and check that tape is not contacting the guide flanges. If necessary, very slightly adjust capstan motor mounting screw 3. If this adjustment is made, return to step 6.
9. Enter maintenance program 02 to perform the shoeshine routine. Check that forward and backward dynamic skew is not greater than 5 microseconds. Also check that skew jump on turnaround is not greater than 5 microseconds (refer to Figure 6-1). Note that turnaround jump is a momentary phenomenon which occurs on forward to backward capstan wheel reversals.

Failure to achieve proper alignment may require reperforming this procedure or may indicate a defective component in the tape path, such as bent swing arm, a defective capstan, or a burred or nicked tape guide or flange. A bent swing arm is often characterized by excessive tape jump on the capstan (referred to in Section 6.4.1, step 5).

```

////////////////////
//// CAUTION ////
////////////////////

```

Never high speed rewind a master alignment tape; always use maintenance program 01.

10. Double check that tape is not being forced against either flange of the upper guide during steady-state forward and backward tape motion. This can be best accomplished by removing the outer flange of the upper guide and checking that tape does not overhang the guide. Reinstall the flange when the check is completed.
11. When the tracking and skew requirements are met, unload and remove the master alignment tape. With power off, reconnect the cable to the WR card and reinstall the card cage cover.
12. Run all internal diagnostics.

6.4.3 BIT POSITION CHECK

1. Load a reel of blank tape with a write enable ring installed.
2. Enter maintenance program 0F, select 1600 bpi density at BOT, and write all ONES on all tracks for about 10 seconds.
3. Use tape developer to develop two feet of the recorded tape.
4. Use a magnifier (jeweler's loupe) with a reticle scale to inspect the developed tape. The distance from the edge of tape to the edge of the outside track (physical track 1, bit 5) should be 0.007 (± 0.003) inch. (Refer to Figure 6-4).

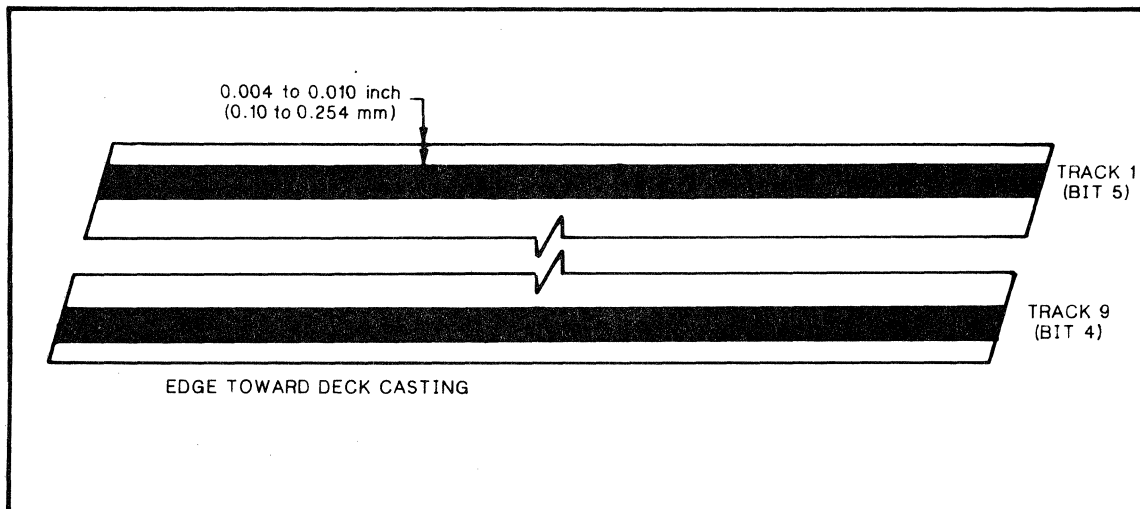

Figure 6-4. Bit Position Check

5. If the outside track does not meet this specification, recheck the capstan alignment (Section 6.4.1).

```
////////////////////  
//// CAUTION ////  
////////////////////
```

Cut the developed tape from the reel and place a new BOT marker on the tape. Do not reuse the developed part of the tape as damage to the read/write head could result.

6.5 READ AMPLITUDE CHECKS

The read amplitude measurements should be made only after all other measurements, alignments, and checks have been performed.

The amplitude measurements are made on the RD card at the +Dif Analog test points (Figure 6-3). Use an oscilloscope to measure each bit from peak to valley. Ground the scope at one of the two ground test points available on the card.

1. Load a master output tape with a write enable ring installed.
2. While positioned at BOT, select 1600 bpi density with the operator panel Density Select switch. Enter maintenance program 0F to write all-ONES on all tracks. (There should be an X in the display.) The signal amplitude of each bit while writing should be 0.7 to 3.0 volts.
3. Enter maintenance program 00 to perform a read forward operation. The signal amplitude of each bit should be within 10% of the signal amplitude measured in step 2.
4. Enter maintenance program 01 to perform a read backward operation. The signal amplitude of each bit should be within 15% of the signal amplitude measured in step 2.
5. After repositioning tape to BOT, select 6250 bpi density. Enter maintenance program 0F and write a high/low frequency pattern on all tracks. The signal amplitude of each bit while writing should be 0.6 to 3.0 volts.
6. Alternately enter maintenance programs 00 and 01 to perform three read passes. On the third read pass (forward), the signal amplitude of each bit should be 90% or greater of the signal amplitude measured in step 5.
7. Enter maintenance program 01 to perform a read backward operation. The signal amplitude of each bit should be within 20% of the signal amplitudes measured in step 6.

(INTENTIONALLY LEFT BLANK)

CHAPTER 7
REMOVAL AND REPLACEMENT

7.1 INTRODUCTION

This chapter provides procedures for the removal and replacement of the field replaceable parts (FRUs). The procedures are arranged by location and/or function under the following major headings:

- Tape Path
- Swing Arms
- Capstan, Reels, and Blower
- Circuit Cards
- Power Supply and Fans

To prevent any possible safety hazard and to prevent damage to the MTS, the main circuit breaker located behind the right front cover must be turned off prior to performing any replacement procedure. Certain procedures specify disconnecting the main power cord as well.

Access to components located on the back of the deck casting may require swinging the casting open on the hinges located on the right side of the casting. This can be accomplished by unlatching the quarter-turn fastener located to the upper left of the file reel (Figure 7-1).

7.1.1 FUSES

Four fuses are used in the MTS; their locations and sizes are:

PK Card	1 amp slow blow
AK Card	20 amp
Retractor Motor (inline)	3/4 amp slow blow
Vacuum Blower (inline)	4 amp slow blow

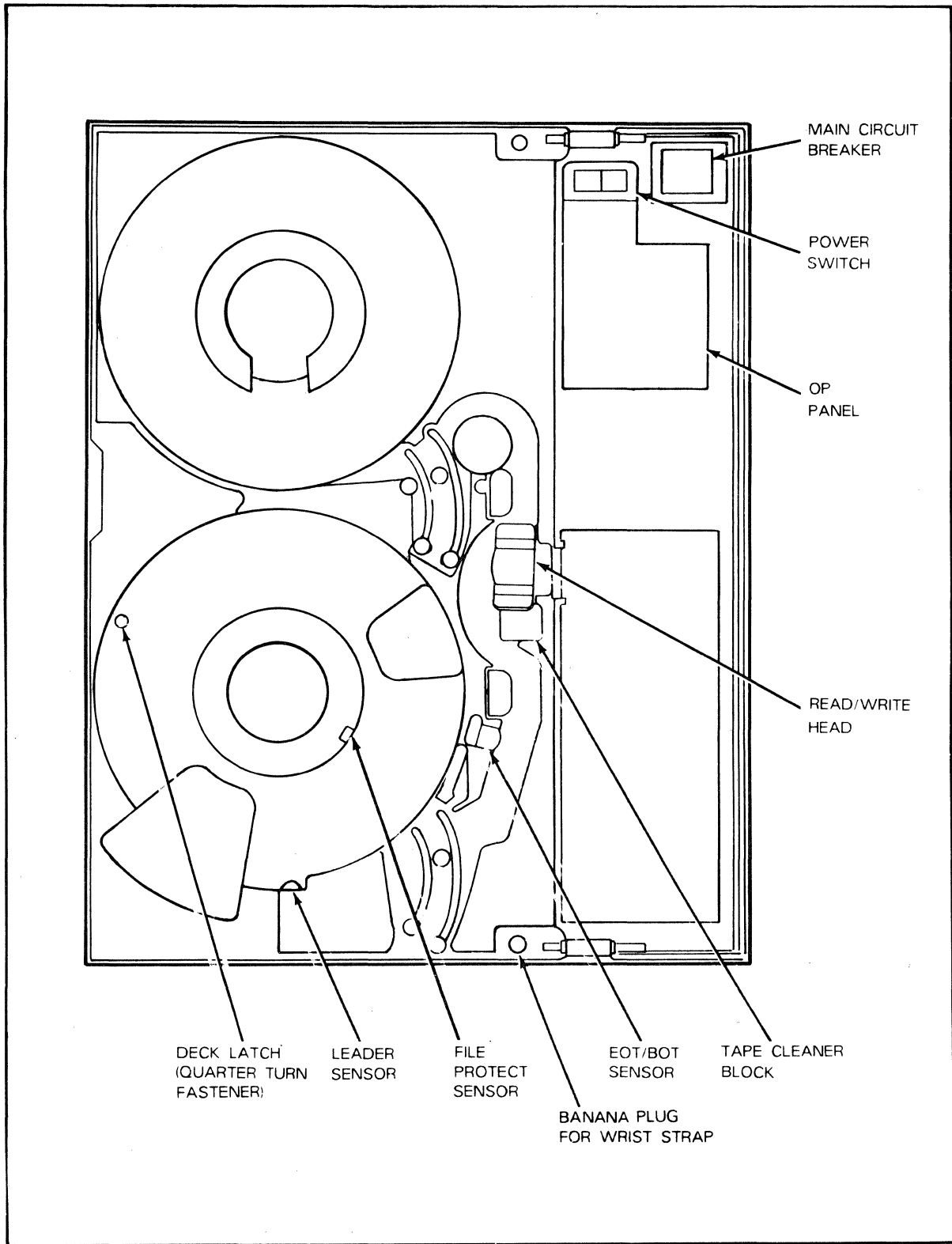

Figure 7-1. 2920 MTS Deck (Front)

7.1.2 TORX SCREWS

The majority of the screws used in the assembly of the MTS are #6 and #10 Torx thread-forming screws. These screws may be removed and reinstalled by using a standard flat-blade screwdriver or optional Torx drivers (Appendix B).

```
////////////////////  
//// CAUTION ////  
////////////////////
```

When reinstalling Torx screws into the aluminum deck casting, ensure that the screw threads are clean, initially start the screw by hand, and do not overtighten the screw.

7.2 TAPE PATH

The locations of the FRUs in this section are shown in Figure 7-1.

7.2.1 EOT/BOT SENSOR REPLACEMENT

1. Switch off the main circuit breaker.
2. Remove the EOT/BOT sensor mounting screw and pull the EOT/BOT assembly from the front of the deck casting.
3. Use the original mounting hardware to install the replacement EOT/BOT assembly. Tighten the mounting screw firmly, using care not to overtighten.
4. Power up the MTS, load a work tape, and check that BOT is properly detected. Enter maintenance program 00 to run tape forward and ensure proper detection of EOT. If a machine check occurs, refer to Appendix A.

7.2.2 LEADER SENSOR REPLACEMENT

1. Switch off the main circuit breaker.
2. Remove the tie-wrap securing the leader sensor cable.
3. Disconnect J28 from the leader sensor.
4. Remove the two leader sensor mounting screws and remove the sensor by pulling the connector through the front of the deck. Use caution not to break the connector.
5. Install the replacement leader sensor using the original mounting hardware. Reconnect P28.
6. Power up the MTS and run all internal diagnostics.

7.2.3 TAPE CLEANER BLOCK REPLACEMENT

1. Switch off the main circuit breaker.

```
////////////////////  
//// WARNING ////  
////////////////////
```

Take care when handling the tape cleaner as the blade is sharp.

2. Remove the cleaner block mounting screw and remove the block from the deck casting.
3. When replacing the tape cleaner block, ensure that the alignment pin in the deck aligns with the hole in the cleaner block and that the cleaner block is seated against the casting before tightening the mounting screw. Tighten the screw firmly, using care not to overtighten.
4. Power up the MTS, load a work tape, enter maintenance program 00 to run tape forward, and visually check that the tape very slightly contacts the blade and screen of the cleaner block.

7.2.4 FILE PROTECT SENSOR REPLACEMENT

1. Switch off the main circuit breaker.

```
////////////////////  
//// CAUTION ////  
////////////////////
```

There may be shims between the file protect sensor and the deck casting which may drop out as the following step is performed.

2. Disconnect J27 from the file protect sensor and remove the screw securing the file protect assembly to the back of the deck casting.
3. Install the replacement file protect sensor over the locating pin and install the sensor mounting screw. Reinstall the shims over the screw. Secure the mounting screw, using care not to overtighten. Reconnect J27.
4. Power up the MTS, load a work tape with a write enable ring installed, and check that the File Protect indicator turns off.
5. Unload the tape, remove the ring; reload the tape, and check that the File Protect indicator is illuminated.

7.2.5 READ/WRITE HEAD REPLACEMENT

1. Switch off the main circuit breaker.
2. Remove the three screws securing the thread door, taking care not to lose the springs.
3. Remove the filler block over the read/write head cables (Figure 7-2).
4. Loosen the three screws securing the card cage cover to the card cage and remove the cover.
5. Disconnect the read cable from the RD card and the write cable from the WR card.
6. Remove the three socket head screws securing the read/write head assembly to the mounting (skew) block and remove the head assembly. Do not remove the fiber block from the brass read/write head.

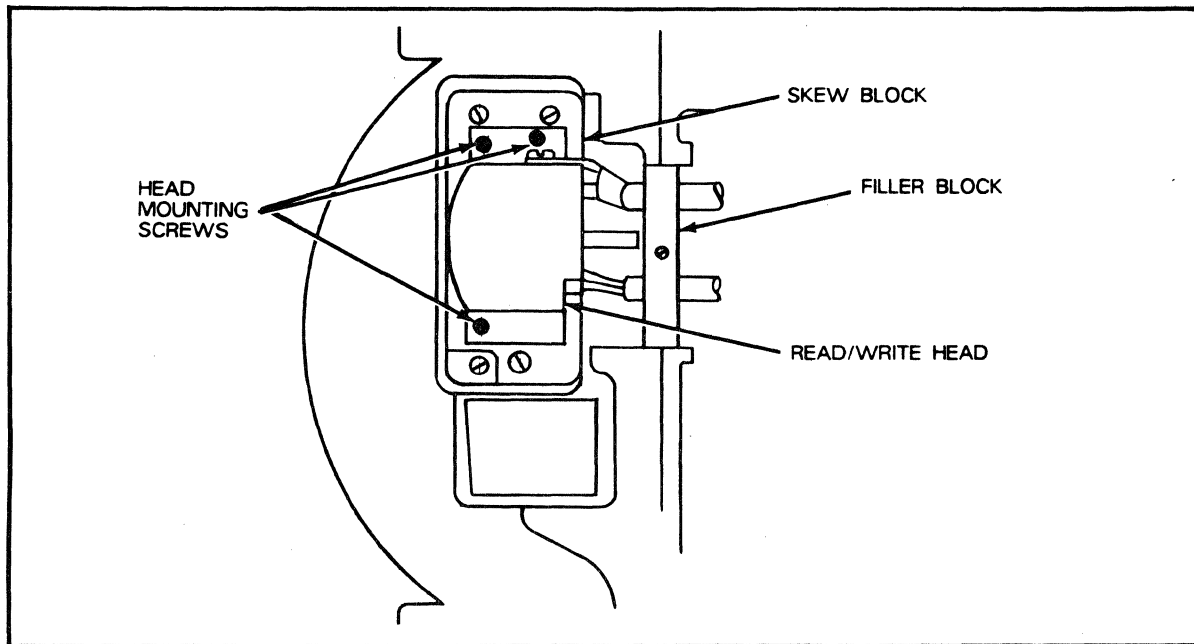

Figure 7-2. Read/Write Head

7. Mount the replacement read/write head on the mounting block, ensuring that the pins are aligned. Firmly seat the read/write head against the mounting block prior to inserting the retaining screws.

//////////////////////////////////////
 //// CAUTION ////
 //////////////////////////////////////

Do not tap or pound on the read/write head assembly as permanent damage can occur.

8. Reconnect the read and write cables.

9. Reinstall the filler block. Ensure that the filler block clamps over the read/write head cable covering and does not pinch any wires that may be unsheathed in this area.
10. Remove the protective covering from the replacement read/write head. (Use this protective covering to protect the tape-contacting area of the original read/write head.) Clean the replacement head with approved Hub and Transport Cleaner.
11. Reinstall the thread door. Operate the door to ensure that no binds exist when opening and closing. Binds could cause improper door seating and vacuum leaks which would affect tape threading.
12. Perform the tape tracking and skew procedure (Section 6.4) and the read amplitude checks (Section 6.5).

7.3 SWING ARMS

7.3.1 LOWER SWING ARM ASSEMBLY REPLACEMENT

1. Switch off the main circuit breaker.
2. Disconnect J24 from the lower swing arm tach assembly; disconnect J34 from the retractor switch assembly; and disconnect J17 from the retractor gear motor.
3. Push up on the bottom of the retractor connecting rod until the swing arms are in the extended position (Figure 7-3).
4. If the retractor arm has a loop end, remove the connecting rod end. If the retractor arm has a slot end, loosen the attachment screw. (Figure 7-3, detail A.)
5. Unhook the lower swing arm tension spring from the spring post on the deck casting.
6. Remove the three screws securing the swing arm pivot plate to the deck casting. Remove the lower swing arm assembly, guiding the rollers through the holes in the deck.
7. Remove the tension spring from the removed swing arm and install the tension spring on the replacement swing arm, making certain that the open side of the hook faces out from the swing arm.

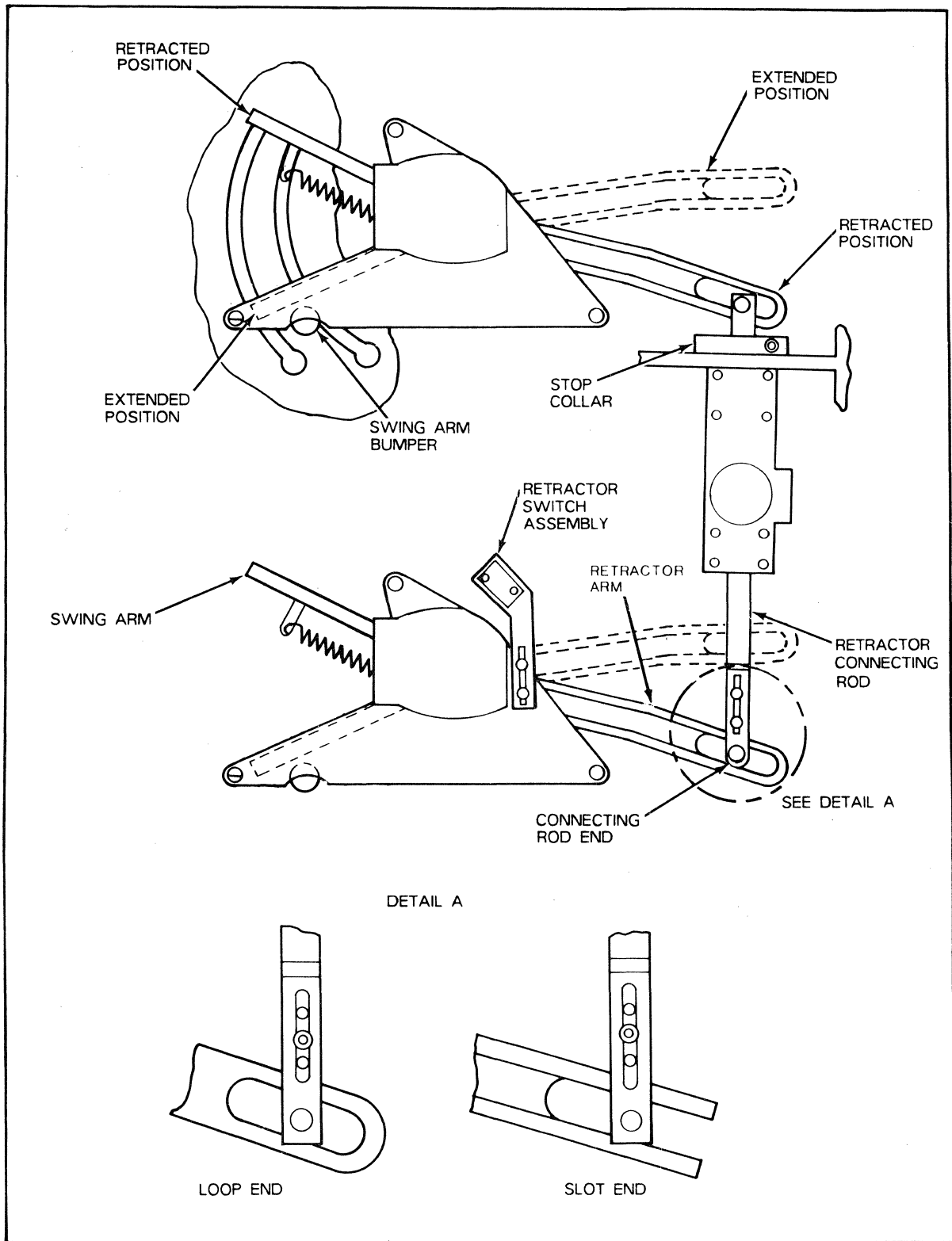

Figure 7-3. Swing Arm Assemblies

8. Mount the replacement swing arm assembly in position and secure it with the original hardware.
9. Reinstall the connecting rod end if removed earlier but do not tighten the attachment screw at this time.
10. Push the connecting rod up approximately 1/4-inch beyond the point where the swing arms contact the swing arm bumpers. Loosen the two screws holding the retractor switch bracket to the swing arm pivot plate. Move the switch assembly until the switch just makes against the retractor arm. Tighten the two screws.
11. Pull the connecting rod down until the stop collar under the rear cover is in contact with the deck casting. Push down on the connecting rod end until the lower swing arm pins are lightly contacting the end of the slots in the deck. Tighten the screw securing the connecting rod end.
12. Push up on the connecting rod until the swing arms are in the extended position. Reconnect the tension spring to the spring post.
13. Reconnect J24 to the tach assembly and J34 to the retractor switch assembly.
14. Power up the MTS. There will be a machine check indication as the retractor motor (J17) is still unplugged. Press RESET on the operator panel.
15. On the diagnostic keypad, press <ENTER PROBE> <6061> <ENTER>. The display should show a two-digit hex character. Move the swing arms gently through their arc; there should be changes in the display value as the arms move out of their bottom position, just below the fixed roller, and again near the top of their arc.

```

////////////////////
//// CAUTION ////
////////////////////

```

To prevent damage to the retractor motor, do not proceed if this test fails.

16. Switch off the main circuit breaker.
17. Reconnect J17 to the retractor gear motor.

18. Power up the MTS. Power-up diagnostics will cycle the swing arms. Enter diagnostic routine 1F to ensure proper operation of the retractors and swing arms.
19. Perform the tape tracking and skew procedure (Section 6.4).
20. Run all internal diagnostics.

7.3.2 LOWER SWING ARM TACH ASSEMBLY REPLACEMENT

1. Switch off the main circuit breaker.
2. Disconnect J24 from the sensor assembly.
3. Remove the plastic snap-off cover over the sensor assembly.
4. The tach disc is secured to the swing arm shaft by a screw and two washers. The larger washer has a small hole that keys onto the dowel pin in the shaft. Remove the screw and washers. (On a few older machines, the tach disc is secured to the shaft by two retaining rings, a spring washer, and a flat washer.)
5. Remove the four socket-head screws securing the sensor assembly to the swing arm pivot plate.
6. Install the replacement tach assembly with the hardware removed in step 5. The two ICs on the tach card should be located to the left. Align the small hole in the tach disc with the dowel pin on the swing arm shaft. Install the large washer, aligning the small hole in the washer with the dowel pin of the shaft. Install the small washer and secure it with the screw.
7. Reinstall the plastic cover over the sensor assembly.
8. Reconnect J24 to the sensor assembly.
9. Power up the MTS. If there is a failure of the tach assembly, the power-up diagnostics should display a fault code in the LED display (refer to Appendix A). To further ensure proper operation, run all internal diagnostics.

10. An additional check of the swing arm tach assembly can be made utilizing the LED display. To perform this check it will be necessary to get the swing arms in their fully extended (downward) position. To do this, enter maintenance program 1F. When the swing arms reach the bottom of their travel, press RESET. This may have to be performed several times to stop the arms in the proper position.

On the diagnostic keypad, press <ENTER PROBE> <6061> <ENTER>. The LED display should be displaying a two-digit hex character. By moving the swing arms gently through their swing arc, there should be a change in the units position of the display when each arm is at the top, at the bottom, and just below the fixed roller post position of the arc. Use caution not to allow the arms to slip free and drop to the bottom under spring tension as this could damage the arms by changing alignment.

7.3.3 UPPER SWING ARM ASSEMBLY REPLACEMENT

1. Switch off the main circuit breaker.
2. Disconnect J23 from the upper swing arm tach, J18 from the vacuum blower, and J17 from the retractor gear motor.
3. Remove the four screws securing the vacuum blower and adopter assembly to the deck casting. Remove the blower and adopter assembly.
4. Remove all screws securing the rear plenum cover to the deck casting. Remove the seal around the capstan motor. Remove the plenum cover.
5. Push up on the bottom of the connecting rod in order to place the swing arms in the extended position (Figure 7-3).
6. Unhook the upper swing arm spring from the spring post on the deck casting.
7. Remove the three screws securing the swing arm pivot plate to the deck casting. Remove the upper swing arm assembly, guiding the rollers through the holes in the deck.
8. Remove the tension spring from the removed swing arm and install the tension spring on the replacement swing arm, making certain that the open side of the hook faces out from the swing arm.

9. Mount the new swing arm assembly in position and secure it with the hardware removed in step 7.
10. Loosen the stop collar clamping screw.
11. Loosen the connecting rod end screw.
12. Push down on the top of the connecting rod until the upper swing arm pins are lightly contacting the end of the slots in the deck casting. Position the stop collar flat against the deck and firmly tighten the screw.
13. Push down on the connecting rod end until the lower swing arm pins are lightly contacting the end of the slots in the deck casting. Tighten the connecting rod end.
14. Push up on the connecting rod until the swing arms are in the extended position. Reconnect the tension spring to the spring post.
15. Reconnect J23 to the upper swing arm tach assembly.
16. Power up the MTS. There will be a machine check indication as the retractor motor (J17) is still unplugged. Press RESET on the operator panel.
17. On the diagnostic keypad, press <ENTER PROBE> <6061> <ENTER>. The display should show a two-digit hex character. Move the swing arms gently through their arc; there should be changes in the display value as the arms move out of their bottom position, just below the fixed roller, and again near the top of their arc.

```

////////////////////
//// CAUTION ////
////////////////////

```

To prevent damage to the retractor motor, do not proceed if this test fails.

18. Switch off the main circuit breaker.

19. Reconnect J17 to the retractor gear motor.
20. Power up the MTS. Power-up diagnostics will cycle the swing arms. Enter diagnostic routine 1F to ensure proper operation of the retractors and swing arms.
21. Power down the MTS and reinstall the rear plenum cover and capstan seal. Ensure that the capstan and swing arm tach wires are in the grooves provided in the deck casting. Secure the cover with the hardware removed in step 6.
22. Reinstall the vacuum blower and adopter assembly using the hardware removed in step 5.
23. Reconnect J18 to the vacuum blower.
24. Power up the MTS and perform the tape tracking and skew procedure (Section 6.4).
25. Run all internal diagnostics.

7.3.4 UPPER SWING ARM TACH ASSEMBLY REPLACEMENT

1. Switch off the main circuit breaker.
2. Disconnect J18 from the vacuum blower.
3. Remove the four screws securing the vacuum blower and adopter assembly to the deck casting. Remove the blower and adopter assembly.
4. Remove all screws securing the vacuum plenum cover to the deck casting. Remove the seal around the capstan motor. Remove the plenum cover.
5. Disconnect J23 from the sensor assembly.
6. Remove the plastic snap-off cover over the sensor assembly.
7. The tach disc is secured to the swing arm shaft by a screw and two washers. The larger washer has a small hole that keys onto the dowel pin in the shaft. Remove the screw and washers. (On a few older units, the tach disc is secured to the shaft by two retaining rings, a spring washer, and a flat washer.)

8. Remove the four socket-head screws securing the tach assembly to the swing arm pivot plate.
9. Install the replacement tach assembly with the hardware removed in step 8. The two ICs on the tach card should be located to the left. Align the small hole in the tach disc with the dowel pin on the shaft. Install the large washer, aligning the small hole in the washer with the dowel pin of the shaft. Install the small washer and secure it with the screw.
10. Reinstall the plastic cover over the sensor assembly.
11. Reconnect J18 to the vacuum blower.
12. Power up the MTS. If there is a failure of the tach assembly, the power-on diagnostics should display a fault code (refer to Appendix A). For a further check of the tach assembly, refer to step 10 of the lower swing arm tach assembly replacement procedure (Section 7.3.2).
13. Power down the MTS and install the vacuum plenum cover and capstan seal, ensuring that the seal is properly aligned around the capstan motor and the hole in the plenum cover. Ensure alignment of all cables emerging from the vacuum plenum in their respective slots prior to tightening the plenum cover screws.
14. Install the vacuum blower and adapter assembly using the hardware removed in step 3.
15. Reconnect J18 to the vacuum blower.
16. Power up the MTS and run all internal diagnostics.

7.3.5 RETRACTOR MOTOR REPLACEMENT

1. Switch off the main circuit breaker.
2. Disconnect J17 from the retractor motor.
3. Gently push upward on the bottom of the connecting rod to position the swing arms in the extended position (Figure 7-3).
4. Remove the four socket-head screws (located at A in Figure 7-4) securing the motor mount to the block guides.

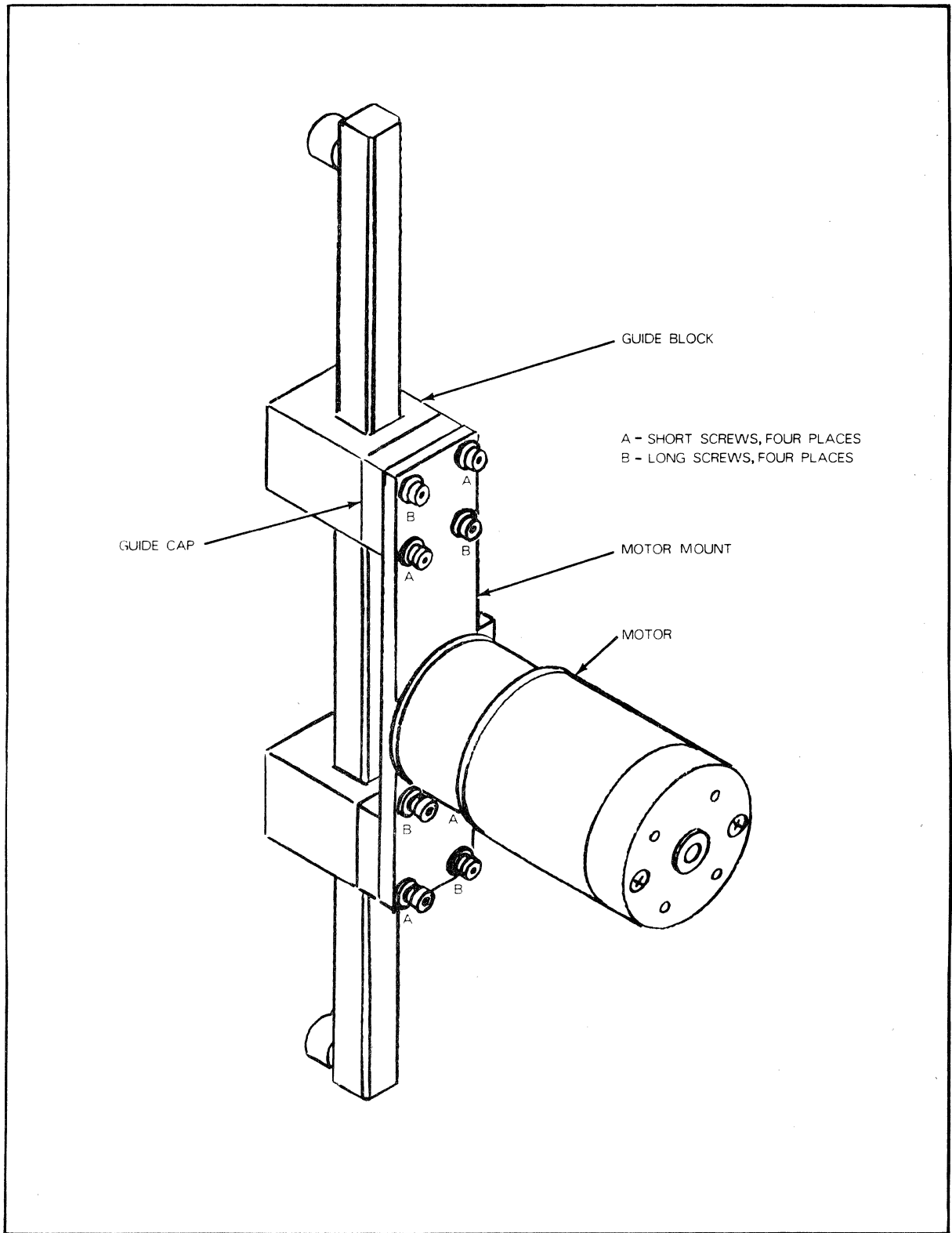

Figure 7-4. Retractor Assembly

5. While supporting the retractor assembly, remove the four remaining screws (located at B in Figure 7-4) securing the motor mount, guide caps, and guide blocks to the deck casting. Be aware that when these screws are removed, the guide caps and guide blocks will be free to fall from their positions.
6. Remove the spur gear from the motor shaft.
7. Remove the three screws securing the motor to the motor mount.
8. Mount the replacement motor to the motor mount using the hardware removed in step 7.
9. Slide the spur gear on the motor shaft leaving 0.65 (± 0.02) inch between the outer end of the gear and the motor mount. Align the setscrews with the flat on the motor shaft and firmly tighten the setscrew.
10. Position the upper guide and upper guide cap on the connecting rod. While holding the motor mount in position, insert one of the long screws through the upper left hole in the motor mount, the guide cap, the guide block, and into the threaded hole in the deck casting. Tighten the screw only enough to hold the parts in position at this time. Insert the second long screw through the lower right hole in the motor mount, aligning the guide cap and guide block into the deck casting.
11. Mount the lower guide block and guide cap in position and insert screws as in step 10.
12. Install the remaining four screws that hold the motor mount to the guide blocks. Ensure that the spur gear and rack mesh. Tighten all screws.
13. Reconnect J17 to the retractor motor.
14. Power up the MTS. The power-on diagnostics will cycle the arms and check for proper operation of the arms during this procedure. Additional cycling of the arms may be accomplished by entering diagnostic routine 1F. The LED display should indicate four dashes for proper operation. A fault code indicates failure and should be investigated before proceeding (refer to Appendix A).
15. Run all internal diagnostics.

7.4 CAPSTAN, REELS, AND BLOWER

7.4.1 CAPSTAN MOTOR REPLACEMENT

1. Switch off the main circuit breaker.
2. Disconnect J18 from the vacuum blower and J16 from the capstan motor.
3. Remove the four screws securing the vacuum blower adpoter to the deck casting. Remove the blower and adpoter assembly.
4. Remove all screws securing the vacuum plenum cover to the deck casting. Remove the seal from around the capstan motor and remove the plenum cover.
5. At the front of the deck casting, remove the screw securing the capstan to the motor shaft. Remove the capstan.
6. Each of the three capstan motor mounting screws retain a spring between the capstan motor and the deck casting. These springs are required during reassembly and are critical to proper operation.

Loosen the three screws securing the capstan motor to the deck casting while supporting the capstan motor from the rear but do not pull the screws from the casting until access is available to remove the springs from the rear. Remove the springs and store them safely for reassembly.

7. All components are reassembled in reverse order of disassembly. The capstan motor should be positioned with the tach cable to the left (as viewed from the rear) and should be routed through the groove in the casting directly below the motor.

The three capstan motor mounting screws should be inserted through the front of the casting and the springs slid on the exposed threaded portions of the screws from the rear.

8. With the springs properly placed on the screws, install the motor and tighten the screws firmly.

9. Replace the plenum cover ensuring that the small diameter of the seal around the capstan motor fits properly into the plenum cover. Check that all cables emerging from the vacuum plenum are located properly in their respective slots in the deck casting prior to completely tightening the plenum cover retaining screws.
10. Reinstall the vacuum blower and adopter assembly. Reconnect all electrical connectors.
11. Perform the tape tracking and skew procedure (Section 6.4).

7.4.2 FILE REEL HUB REPLACEMENT

1. Remove the three socket-head screws securing the hub cover to the hub assembly. Remove the hub cover.
2. Remove the three socket-head screws securing the hub assembly to the clamp collar. Slide the hub off the reel motor shaft. If only the hub is being replaced, it is not necessary to remove the clamp collar.
3. Slide the replacement file reel hub assembly on the reel motor shaft. Align the screw holes in the hub with the holes in the clamp collar. Insert the mounting screws and tighten securely.
4. Reinstall the hub cover, using care not to overtighten the screws as damage to the hub cover may occur.
5. Power up the MTS, load a work tape, and enter maintenance program 00 to run tape forward. Check that tape does not contact either flange of the reel. Perform the same check using maintenance program 01 to run tape backward.

If necessary, use the clamp collar to reposition the hub until the tape wraps on the reel without contacting the reel flanges.

6. Check the alignment and operation of the file protect sensor. To check for proper operation of file protect, load a work tape with a write enable ring installed and check that the File Protect indicator turns off. Unload the tape, remove the ring, reload the tape, and check that the File Protect indicator is illuminated.

7.4.3 FILE REEL MOTOR REPLACEMENT

1. Switch off the main circuit breaker.
2. Disconnect J14 from the file reel motor.
3. Remove the three socket-head screws in the hub cover. The hub cover can now be removed by opening the hub latch and pulling off the cover with a slight counterclockwise twist to clear the hub latch.
4. Remove the three screws securing the hub assembly to the clamp collar and remove the hub assembly.
5. Loosen the 3/16-inch socket-head screw holding the clamp collar to the motor shaft and slide the collar off the shaft.
6. Remove the three screws securing the reel motor to the deck casting and remove the motor.
7. Reassemble in reverse order. The inner edge of the clamp collar should be positioned 0.338 inch from the front of the reel motor.
8. To check for proper alignment of the reel to the tape path, power up the MTS, mount and load a work tape, enter maintenance program 00, and run tape forward to EOT. Rewind while observing the tape as it wraps back on the file reel: The tape should not contact either flange of the reel. If necessary, use the clamp collar to reposition the hub until the tape wraps on the reel without contacting the reel flanges.
9. Check the alignment and operation of the file protect sensor. To check for proper operation of file protect, load a work tape with a write enable ring installed and check that the File Protect indicator turns off. Unload the tape, remove the ring, reload the tape, and check that the File Protect indicator is illuminated.

7.4.4 MACHINE REEL MOTOR REPLACEMENT

1. Switch off the main circuit breaker.
2. Disconnect J15 from the reel motor.
3. Remove the machine reel cover.
4. Remove the three screws securing the machine reel hub cap to the hub and remove the cap and outer flange.
5. Remove the three screws securing the hub assembly to the clamp collar and remove the hub assembly.
6. Loosen the 3/16-inch socket-head screw holding the clamp collar to the motor shaft and slide the collar off the shaft.
7. From the front of the deck casting, remove the four screws securing the machine reel motor to the deck casting. Remove the motor.
8. Install the replacement reel motor.
9. Install the clamp collar on the replacement reel motor shaft. The inner edge of the clamp collar should be positioned 0.110 inch from the front of the reel motor.
10. Reassemble all components.
11. To check for proper alignment of the reel to the tape path, power up the MTS, load a work tape, and enter maintenance program 00 to run tape forward. Tape should not contact either flange of the reel as it wraps on the machine reel. The column door and the machine reel cover may be removed once tape has been loaded to allow observation of the machine reel area.

If necessary, use the clamp collar to reposition the hub on the motor shaft until tape wraps on the reel without contacting the reel flanges.

7.4.5 VACUUM BLOWER REPLACEMENT

1. Switch off the main circuit breaker.
2. Disconnect J18 from the vacuum blower.
3. Remove the four screws securing the vacuum blower to the vacuum blower adapter. Remove the blower and the blower plate.
4. Remove the blower plate from the blower and install on the plate on the replacement blower.
5. Reassemble in reverse order. When installing the four screws, ensure that the threads of all screws are sufficiently caught before completely tightening any one screw. Reconnect J18 and check out the subsystem by performing several tape load operations.

7.5 CIRCUIT CARDS

7.5.1 CARD CAGE CIRCUIT CARDS REPLACEMENT

1. Switch off the main circuit breaker.
2. Remove the right front cover by pulling the snap fasteners at the top and bottom of the cover.
3. Loosen the three screws securing the card cage cover and remove the cover.
4. Wear a wrist strap (Appendix B) and plug its banana clip into the receptacle on the deck casting (Figure 7-1).
5. Remove the desired circuit card by pulling on the ends of the tabs at the top and bottom of the card. The RD and WR cards have front edge connectors that must be disconnected before removing the cards.
6. When inserting the replacement card, ensure that the tab ends are locked in the mating slots of the card cage.
7. Power on the MTS and run all internal diagnostics to ensure proper operation.

7.5.2 FRONT OPERATOR PANEL REPLACEMENT

1. Switch off the the main circuit breaker and disconnect the main power cord.
2. Remove the three screws securing the front panel card (KK) to the deck casting.
3. Remove the electrical connectors from the back of the card. Note the orientation of the connectors for proper reassembly.
4. Reassemble in reverse order.
5. Power up the MTS and run maintenance program 08, the Keyboard/LED Test. Each depressed key displays its ASCII code. The Reset key terminates the test.

7.5.3 AK CARD REPLACEMENT

1. Switch off the main circuit breaker and disconnect the main power cord.
2. Remove J11, J12, and J13 from the AK card. The connectors are keyed and labeled.
3. Remove the seven screws securing the AK card to the capacitor bank, using care not to drop the screws into the fans or card cage. It may be necessary to hold the standoffs behind the AK card with a 5/16-inch open-end wrench when loosening the screws. Remove the card.
4. When reassembling the AK card to the capacitor bank, start all screws before completely tightening any one screw. As the screws are making electrical contact, ensure they are tightened securely.
5. Reconnect all three electrical connectors.
6. Power up the MTS and check all power supply output voltages (Section 6.3).
7. Run all internal diagnostics to ensure proper operation.

7.5.4 PK CARD REPLACEMENT

1. Switch off the main circuit breaker and disconnect the main power cord.
2. Remove the clear plastic safety cover from the PK card standoffs.
3. Remove the insulator boot and the wire from the ferro capacitor.
4. Remove the wires connected to the top edge of the PK card.
5. Pull the card from the transformer. Pull the wire that was attached to the ferro cap through the sense coil on the PK card.
6. Reassemble in reverse order.
7. Power up the MTS and check all power supply output voltages (Section 6.3).
8. Run all internal diagnostics to ensure proper operation.

7.5.5 MOTHERBOARD REPLACEMENT

1. Switch off the main circuit breaker and disconnect the main power cord.
2. Loosen the three screws securing the card cage cover and remove the cover.
3. Unlatch all circuit cards in the card cage and slide the cards forward. It is not necessary to slide the cards completely out of the cage.
4. Remove all electrical connectors from the motherboard.
5. Disconnect the four wires from the solid state relay. The wires are marked to show the relay connections.
6. Remove the eight screws securing the motherboard to the card cage.
7. Reassemble in reverse order. Insert the circuit cards in the

motherboard connectors before tightening the eight motherboard mounting screws to ensure proper alignment of the motherboard.

8. Power up the MTS and run all internal diagnostics to ensure proper operation.

7.6 POWER SUPPLY AND FANS

7.6.1 RECTIFIER ASSEMBLY REPLACEMENT

1. Switch off the main circuit breaker and disconnect the main power cord.
2. Disconnect the ground strap located on the left side (as viewed from rear) of the rectifier assembly.
3. Loosen the three remaining screws securing the rectifier assembly to the deck casting. The rectifier assembly can be slid to the right to clear the screw heads and pulled to the rear.
4. Reassemble in reverse order.
5. Power up the MTS and check all power supply output voltages (Section 6.3).
6. Run all internal diagnostics to ensure proper operation.

7.6.2 TRANSFORMER REPLACEMENT

1. Switch off the main circuit breaker and disconnect the main power cord.
2. Remove the PK card. Refer to Section 7.5.4 for the procedure.
3. Remove and mark the remaining wire from the ferro capacitor.
4. Disconnect J12 from the AK card.
5. Disconnect J31 located beneath the power transformer.

6. Loosen all four screws securing the transformer brackets to the deck casting. The two screws on the right side can now be completely removed.
7. Slide the transformer to the right and off the two remaining screws. Use caution as the transformer is heavy (25 pounds; 11.4 kg).
8. Transfer the insulated stand-offs from the removed transformer to the replacement transformer.
9. Reassemble in reverse order.
10. Power up the MTS and check all power supply output voltages (Section 6.3).
11. Run all internal diagnostics to ensure proper operation.

7.6.3 MAIN CIRCUIT BREAKER REPLACEMENT

1. Switch off the main circuit breaker and disconnect the main power cord.
2. The circuit breaker is snapped into its receptacle from the front of the deck. Recessed areas are formed on either side of the breaker to enhance removal with a screwdriver blade.
3. Note the locations of the electrical connections before disconnecting them. Prevent wires from falling into the deck casting recess.
4. Reassemble in reverse order.

7.6.4 COOLING FAN REPLACEMENT

1. Switch off the main circuit breaker and disconnect the main power cord.
2. Disconnect J31 located near the card cage.
3. Remove the ground wire from the fan assembly.
4. Loosen the screw securing the fan assembly to the card cage.

5. Slide the fan assembly back in order to free the locking tabs at the forward end of the fan assembly, then slide the assembly forward and out from under the securing screw, and finally pivot the assembly in order to the left to clear the card cage and the motherboard.
6. An individual fan may be replaced by removing it from the mounting plate. Check the airflow direction as indicated on the side of the fan prior to installation. Air flow should be upward. The fan guard should be removed for attachment to the replacement fan.
7. Reassemble in reverse order.
8. Power up the MTS and check the fans for proper operation.

CHAPTER 8

DIAGNOSTIC/MAINTENANCE PROGRAMS

8.1 INTRODUCTION

The 2920 Magnetic Tape Subsystem (MTS) diagnostic programs are capable of detecting fault conditions in the tape subsystem and isolating failures within a specific number of field replaceable units (FRUs). The programs, which consist of internal diagnostic programs and maintenance programs, reside in the 8K Diagnostic PROM.

An optional set of diagnostics, external programs, are released on floppy diskettes and run from a Storage Technology Corporation Model 3910 Detached Diagnostic Device via the standard 1900 interface. The external routine library provides complete 2920 interface verification and limited online exercising. The 1900 Diagnostic Monitor, under which the external diagnostic routines are run, also provides a high-level, interpretive language with which to create online command sequences quickly. (Refer to the 3910 User's Guide For 1900 Diagnostics Manual, PN 9613.) An ANSI Fortran (X3.9-1966) source code equivalent of the 1900 Diagnostic Monitor and routine library is also available for installation. This option allows testing of the entire interface from the host system to the 2920 MTS. (Refer to the 1900 Fortran Monitor Manual, PN 9646.)

8.1.1 TEST INITIATION

The internal diagnostic package provides several options in the execution of diagnostic library routines. The following panel key sequences are used to implement these options:

Complete internal package:	<ENTER DIAG>,10,<ENTER>
Individual test:	<ENTER DIAG>,id,<ENTER>
Test run modification:	<ENTER DIAG>, n,<ENTER>
Continue:	n = 5
Loop:	6
Bypass Error:	7

Note that the test run modification entry is to be followed by the individual test entry to which that option is applied. Options can be combined but cannot be applied to any other Section 0 routine (maintenance routines).

8.1.2 STATUS BUFFERS

In many cases the fault code dictionary (Appendix A) will refer to the status buffers A, B, or C (e.g., Status B-2). Access to any of the 16 bytes contained in each buffer is obtained via the maintenance routine of matching ID (e.g., <ENTER>DIAG>,B,<ENTER>). Once entered, the buffer can be scrolled through sequentially by pressing <ENTER>. Pressing <ENTER> displays the buffer ID and index (B1,B2...); releasing <ENTER> displays the contents. The index is presented in hexadecimal notation (as is all data displayed) and wraps around upon reaching the last entry (...BE,BF,B0,B1...).

8.2 SECTION 0 - MAINTENANCE ROUTINES

The maintenance routines (Table 8-1) have several functions. They are generally used with certain set-up procedures and are not intended to isolate hardware malfunctions but they do permit the operator to exercise the machine or place the subsystem in a basic operating mode (e.g., read forward or write).

Table 8-1. Maintenance Routines

ROUTINE NAME	ROUTINE ID
Forward Motion	00
Backward Motion	01
Shoeshine Motion	02
Start/Stop Motion	03
Continue Option	05
Loop Option	06
Bypass Error Option	07
Keyboard/LED Driver	08
Reel/Capstan Driver	09
Status A Display	0A
Status B Display	0B
Status C Display	0C
Maintenance Write	0E
Maintenance Write	0F

Maintenance routines can also be used to alter test program characteristics by setting options to Loop, Continue, and Bypass Error. During the execution of many of these routines, the keyboard can be used for examining subsystem memory space locations, allowing the display of machine status at the front panel while the machine is in use (offline mode only).

The maintenance routines are initiated by entering the routine ID number at the diagnostic keypad. Refer to Section 2.5 for descriptions of the diagnostic keypad.

8.2.1 FORWARD MOTION (00)

The Forward Motion routine initiates forward tape motion in read mode. If subsystem density is to be selected, it must be done while the tape is positioned at BOT and prior to the initiation of this routine. Tape motion halts when EOT is detected or when the Reset key is pressed.

8.2.2 BACKWARD MOTION (01)

The Backward Motion routine initiates backward tape motion in read mode. Subsystem density remains as indicated on the front panel. Tape motion halts when BOT is detected or when the Reset key is pressed.

8.2.3 SHOESHINE MOTION (02)

The Shoeshine Motion routine performs a continuously alternating forward/backward motion with the motion duration selectable at the front panel. This routine halts when EOT is detected in the forward direction, BOT is detected in the backward direction, or when the Reset key is pressed. The least significant display digit indicates the operating rate and direction as follows (pressing <ENTER> selects the next rate):

Forward motion time	Display Contents
2 sec	(@2 1)
1 sec	(@2 2)
500 ms	(@2 3)
250 ms	(@2 4)

8.2.4 START/STOP MOTION (03)

The Start/Stop Motion routine performs a start/stop-type motion with the start/stop rate and direction selectable at the front panel. This routine halts when EOT is detected in the forward direction, BOT is detected in the backward direction, or when the Reset key is pressed. The least significant display digit indicates the operating rate and direction as follows (pressing <ENTER> selects the next rate):

Motion/Stop Time (each)	Least Sig Digit of Display	
	Forward	Backward
500 ms	(1)	(5)
250 ms	(2)	(6)
125 ms	(3)	(7)
63 ms	(4)	(8)

8.2.5 CONTINUE OPTION (05)

The Continue Option routine sets the Continue option for a subsequent diagnostic run request. This modifies the monitor's handling of diagnostic termination, allowing execution to continue with the next entry in the internal test library rather than to the normal return-to-idle response (----). Execution terminates for any one of the following conditions:

1. An error is detected (unless the Bypass Error option is set).
2. The end of the internal test library is detected (unless the Loop option is set).
3. The Reset key is pressed.

8.2.6 LOOP OPTION (06)

The Loop Option routine sets the Loop option for a subsequent diagnostic run request (see Test 05 if used with the Continue option). If the Continue option is not set, the Loop option will result in the repeated execution of the subsequently requested diagnostic routine. Execution terminates for any one of the following conditions:

1. An error is detected (unless the Bypass Error option is set).
2. The Reset key is pressed.

8.2.7 BYPASS ERROR OPTION (07)

The Bypass Error Option routine sets the Bypass Error option for a subsequent test run request. This option is only valid if issued with a Continue or Loop Option (Tests 05 and 06).

8.2.8 KEYBOARD/LED DRIVER (08)

The Keyboard/LED Driver routine samples the keyboard input (ASCII data) and copies the data to all four digits of the display. Pressing the Reset key terminates the routine; holding the key down causes every other LED on the front panel to illuminate. When the key is released, these LEDs extinguish and the remaining LEDs illuminate. This permits the operator to verify independent functioning of all panel indicators.

8.2.9 REEL/CAPSTAN DRIVER (09)

The Reel/Capstan Driver routine drives the reels and capstan in various modes selectable at the front panel. The mode number is displayed as the least significant digit on the panel display. Initially; Mode 0, all servos are nulled. Each time <ENTER> is pressed, the mode number seen in the display is bumped and the appropriate motion occurs as defined below:

Mode 0: Servo drivers nulled

- 1: Capstan forward, uP control (approx 25 ips), low gain
- 2: Capstan forward, uP control (approx 25 ips), high gain
- 3: Capstan forward, velocity control (50 ips), high gain
- 4: Capstan backward, uP control (approx 25 ips), low gain

- 5: Capstan backward, uP control (approx 25 ips), high gain
- 6: Capstan backward, velocity control (50 ips), high gain
- 7: Machine reel forward, thread mode
- 8: Machine reel backward, thread mode
- 9: Machine reel forward, current mode

- A: Machine reel backward, current mode
- B: File reel forward, thread mode
- C: File reel backward, thread mode
- D: File reel forward, current mode
- E: File reel backward, current mode

The routine repeats this sequence upon reaching the last entry. Pressing the Reset key terminates the routine.

8.2.10 STATUS A DISPLAY (0A)

The Status A Display routine allows the display of the 16 bytes in status area A. While <ENTER> is pressed, the index to the status bytes (A0,A1,...) is displayed in the first two display digits; when released, the contents of that location is displayed in the last two digits. Upon reaching the last byte, the sequence is repeated (...AE,AF,A0,A1,...). The panel is returned to idle by pressing the Reset key or <CLEAR>.

The last location examined is remembered, and can be accessed using <DISP ADDR> or <ENTER PROBE> without an address entry.

8.2.11 STATUS B DISPLAY (0B)

The Status B Display routine displays the contents of the status area B (see Test 0A).

8.2.12 STATUS C DISPLAY (0C)

The Status C Display routine displays the contents of status area C (see Test 0A).

8.2.13 MAINTENANCE WRITE (0E)

This Maintenance Write routine erases all tracks and writes one track as selected at the front panel. Initially all tracks are erased by setting all diagnostic dead track bits, thereby disallowing write trigger transitions (an X is displayed in the least significant display digit). <ENTER> may then be used to select the writing of one track only and the track number (0-7,P) is displayed. The track selections repeat upon reaching track P. Pressing the Reset key terminates the routine.

Note that the density in which the tape is to be written must be selected at BOT (use the Density Key) prior to initiating this routine. If PE density is selected, the track written will contain the all-ONES frequency appropriate for PE density. If GCR is selected, two frequencies will be written: the higher frequency representing the all-ONES data rate, and the lower representing the minimum frequency allowed in GCR recording (one-third the all-ONES rate). This feature is provided for dynamic range measurement of the read channel.

8.2.14 MAINTENANCE WRITE (OF)

This Maintenance Write routine writes in all tracks or allows the selection of one track to be erased. Initially all tracks are written by resetting all diagnostic dead track bits, thereby allowing write trigger transitions (an X is displayed in the least significant display digit). <ENTER> may then be used to select the erasure of one track only and the track number (0-7,P) is displayed. The track selections repeat upon reaching track P. Pressing the Reset key terminates the routine.

8.3 INTERNAL DIAGNOSTICS

The internal diagnostics are a set of routines (Table 8-2), each executable by specifying a program ID at the diagnostic keypad. The internal diagnostics are arranged numerically so that if they are run in sequence, they will test the subsystem from the microprocessor and RAM outward to the drive. These routines are divided into four sections: power-up, formatter, transport, and read/write tests.

8.3.1 SECTION 1 - POWER-UP TESTS

The power-up tests are automatically executed whenever power is applied to the subsystem or they can be run individually from the diagnostic keypad by entering the test ID number when the panel is idle. These routines ensure basic operation of the microprocessor and control logic of the subsystem which includes the testing of memory (RAM and PROM checksum), counter/timers, interrupt hardware, stuck keyboard conditions, servo control register loop back, status from the data path and write cards, and swing-arm motions. Errors that occur during power-up will display a three-digit hexadecimal fault code and flash a machine check indication. This condition will prevent further subsystem operation until the Reset key is pressed. Errors that occur following the manual initiation of an internal diagnostic test will also display a fault code but will not flash a machine check indication or prevent placing the subsystem online.

8.3.1.1 Test Package Initiator (0)

The Test Package Initiator routine sets the Continue option and returns the subsystem to the monitor. Testing begins with Test 12 and continues until its completion or an error is detected.



8.3.1.2 Memory/PROM Checksum (12)

The Memory/PROM Checksum test checks all of memory (RAM and PROM). RAM is tested (both the diagnostic loop write-to-read buffer and functional memory) for its ability to write, read, write complement, and read with a demanding Z80 instruction sequence. The PROMs are read and the checksums verified.

8.3.1.3 Counters (13)

The Counters test checks all three counters for their down-count ability through the entire 16-bit count range. A terminal count pulse is expected at the interrupt controller (8259) for each counter in a fixed sequence following a fixed delay.

8.3.1.4 Interrupt Controller (14)

The Interrupt Controller test checks that all counter-related interrupts are functional. Counters 0, 1, and 2 are set for delays of 200, 400, and 600 microseconds, respectively. When the interrupts are received by the handler, a bit corresponding to the one received is set in a processor register, allowing verification of the sequence of interrupts received.

8.3.1.5 Keyboard Status (15)

This Keyboard Status test ensures that there are no stuck-active conditions in the keyboard control and status registers. All row selects (0 through 4) are individually activated and status is read to check the column-depressed response. An error will be displayed if more than one key is indicated as being active.

8.3.1.6 Servo-LSI Register Loop (18)

The Servo-LSI Register Loop routine tests the loopable paths through the XRS and XCS chips including the capstan position counter (memory addresses 6022-25), capstan velocity register (6026-29), and both swing arm position counters (6030-35). All registers are loaded with walking ONEs and ZEROs such that independent functioning of these addresses can be verified.

8.3.1.7 Data Path Status (1B)

The Data Path Status routine checks that proper status is seen from the data path card following resets in both PE and GCR modes. Status is examined in registers 6040 through 6045.

8.3.1.8 Write Card Status (1D)

The Write Card Status routine enables each sensor individually via the write control register (6068). When the associated control lines are disabled, the following conditions must be met:

1. EOT, BOT, and Leader Status must be off
2. File Protect must be asserted
3. Tape Present is a don't care (due to the possibility of tape in the thread path)

Also, Sensor Error must never be asserted as this indicates detection of an impossible combination by the WR write card (e.g., LED off but detector active).

This routine also ensures resetting write/erase currents. Write Current Active is tested by the first write test in the diagnostic package.

8.3.1.9 Release/Retract Swing Arms (1F)

The Release/Retract Swing Arms routine drives the swing arms to the extent of their travel. The swing arms are first driven to their extended position and then returned to retracted position. During the retract motion, proper phasing of the motion tachs is checked. A software count representing the distance travelled is expected to match that detected by the position counters of the SV servo card XRS chip. (If tape is detected in the thread path, all count compares are bypassed.)

8.3.2 SECTION 2 - FORMATTER TESTS

The formatter tests ensure proper data path operation by simulating record writing in a loop write-to-read mode. No tape motion takes place in these tests; all servo activity is disabled (EPO) if a tape is loaded.

8.3.2.1 PE Basic Loop Write-to-Read (22)

The PE Basic Loop Write-to-Read (LWR) routine is the initial test of the subsystem's PE loop write-to-read capability. This routine sets the subsystem to the PE mode and simulates records of selected data and byte counts.

The first six patterns (all-ONES, all-ZEROs, AA-55, 55-AA, walking ZERO bit, and walking ONE bit) are written as short records (five to eight bytes). In each of these cases, data is retained in the read path for subsequent data comparison. These pattern and length combinations result in the transfer of 1128 bytes in 144 records.

The next eight records are written as long records (one to eight kilobytes). For these records, a 32-byte data pattern is repeated up to the desired length (based on time) and then STOP is asserted to the DP data path card. When the data path indicates completion, status is used to indicate data integrity. Approximately 36 kilobytes are transferred in the eight records.

These transfers involve the IF processor card, DP data path card, and RD read card. No errors are forced by this test so that the occurrence of an error will result in a fault code.

8.3.2.2 PE LWR Velocity (23)

The PE LWR Velocity routine verifies the velocity error detection thresholds normally enabled during PE writes. A capstan tach will be approximately 20 tach periods in length. The velocity check circuitry counts the number of VCO pulses received from the RD card for each tach period. Four records will be used to simulate velocity errors of +12.5%, +5.6%, -8.2%, and -11.7%. Of these, the first and last records will exceed the 10% threshold and a Velocity Check is expected.

8.3.2.3 GCR Basic Loop Write-to-Read (24)

The GCR Basic Loop Write-to-Read (LWR) routine is the initial test of the subsystem's GCR loop write-to-read ability. This routine sets the subsystem to GCR mode and simulates records of selected data and byte counts.

The first six patterns (all ONES, all ZEROs, AA-55, 55-AA, walking ZERO bit, and walking ONE bit) are written as short records (one to six bytes). In each of these cases, data is

retained in the read path for subsequent data comparison. These pattern and length combinations result in the transfer of 660 bytes in 120 records.

The next eight records are written as long records (one to eight bytes). For these records, a 32-byte data pattern is repeated up to the desired length (based on time) and then STOP is asserted to the data path card. When the data path indicates completion, status is used to indicate data integrity. Approximately 36 kilobytes are transferred in the eight records.

These transfers involve the IF processor card, DP data path card, and RD read card. No errors are forced by this test so that the occurrence of an error will result in a fault code.

8.3.2.4 GCR LWR Velocity (25)

The GCR LWR Velocity routine verifies the velocity error detection thresholds normally enabled during GCR write operations. A capstan tach is diagnostically simulated during the writing of records approximately 20 tach periods in length. The velocity check circuitry counts the number of VCO pulses received from the RD card for each tach period. Four records will be used to simulate velocity errors of +12.5%, +5.6%, -8.2%, and -11.7%. Of these records, the first and last records will exceed the 10% threshold and a Velocity Check is expected.

8.3.2.5 PE LWR, One Track Dead (26)

The PE LWR, One Track Dead routine tests the error detection and correction ability of the PE loop write-to-read function. Sixty-four short records and eight long records are written with a test track forced inactive. Track 0 is the initial test track, shifting up to track P with each successful completion of the 72 records.

The short records use the walking ZERO bit pattern with a length of eight bytes. Corrected data is compared to the write buffer upon readback. For the short records, dead tracking is performed throughout from preamble through postamble. This procedure tests the hardware's ability to recognize a late ready track.

The long records are identical to those used in Test 22 with lengths from one to eight kilobytes. Dead tracking starts approximately halfway through the preamble ensuring "record latch" and testing early track ready indications.

Only correction status is expected for these single track-in-error situations.

8.3.2.6 GCR LWR, One Track Dead (27)

The GCR LWR, One Track Dead routine tests the error detection and correction ability of the GCR loop write-to-read function. Forty-eight short records and eight long records are written with a test track forced inactive. Track 0 is the initial test track, shifting up to track P with each successful completion of the 56 records.

The short records use the walking ZERO bit pattern with a length of eight bytes. Corrected data is compared to the write buffer upon readback. For the short records, dead tracking is performed throughout from preamble through postamble. This procedure tests the hardware's ability to recognize a late ready track.

The long records are identical to those used in Test 22 with lengths from one to eight kilobytes. Dead tracking starts approximately halfway through the preamble ensuring "record latch" and testing early track ready indications.

Only correction status is expected from the data path card (DP) for these single track-in-error situations.

8.3.2.7 PE LWR, Two Tracks Dead (28)

The PE LWR, Two Tracks Dead routine checks that two tracks in error are identified and that an uncorrectable record is flagged. The test procedure is as described for Test 26 except that the dead tracking is performed on all 36 permutations of two tracks from 0 to 7 and P. This procedure results in the transfer of 18,432 bytes in 2,403 short records and 1296 kilobytes in 288 long records.

This test expects the following status from the data path card: Uncorrectable, Partial Record, Multi-track Error, and End Data Check.

8.3.3 SECTION 3 - TRANSPORT TESTS

Once the formatter has been checked, the diagnostic routines test the tape transport. The transport tests ensure proper servo operation, tape handling during a load operation, motion control, and high-speed rewind functions.

8.3.3.1 Unload/Load (32)

The Unload/Load routine tests the reel and capstan servos by cycling through an unload/load sequence. Testing takes place primarily during the load sequence as the unload phase is not guaranteed to occur. The capstan is cycled through a forward and backward ramp and the tach examined for phasing through a complete revolution. The reel servos are driven in both current and voltage feedback modes and the proper response is expected of the pump up/down drive signals. The drive will complete the thread sequence and stop just after the swing arms are in servoing position.

Note that this routine interrupts the normal rewind-to-BOT procedure so that Test 34 can diagnose any ramp problems. This means that the sizing of the file reel and the initialization of the adaptive motion variables are not yet complete. These will occur upon completion of the next rewind, whether it be commanded offline from the panel, online from the interface, or a result of the continuation of this test package (Test 36).

8.3.3.2 Drive Basic Motion (34)

The Drive Basic Motion routine performs the first test of loaded drive motion in the diagnostic package. The drive's start/stop characteristics are analyzed by allowing the functional code to control motions with the normal interrupts (250 us capstan acceleration/deceleration; 1 ms capstan at velocity; 10 ms reel control). This routine monitors the result of the functional code control: that capstan position error limits are not exceeded during the ramps, that swing arm position feedback for the reel servo is within a certain range (isolating tape slip problems), and that capstan velocity is correct during sustained motion.

8.3.3.3 Drive Rewind (36)

The Drive Rewind routine tests the performance of the functional rewind task. Following a 125-foot forward motion (providing that EOT is not detected), a rewind is initiated. A ramp up to a minimum of 175 ips is expected. This only verifies that initial ramp up can be completed without excessive reel error but not that the nominal rewind speed of 220 ips can be attained.

8.3.4 SECTION 4 - READ/WRITE TESTS

The Read/Write Tests check the subsystem read/write electronics. Data transfer from the data path card, read backward/forward operations, and tape positioning (PE and GCR) are verified by these tests.

8.3.4.1 PE Amplitude Sensor (42)

The PE Amplitude Sensor routine is the first test of the subsystem read/write electronics. Write Current Status is verified before any motion occurs (the drive must be write enabled). This routine checks amplitude sensor response by writing (in PE density) an all-ONEs pattern on all tracks (using the Write ARA command). Verification of over 30 feet of tape will isolate bad tape as a failure mechanism. The individual functioning of all amp sensors is then tested by using the diagnostic dead-track control to write one-track-at-a-time and all-but-one-track combinations (nine times each). Finally, gross write-to-read feedthrough problems are detected by toggling write triggers with tape motion halted.

8.3.4.2 GCR Amplitude Sensor (43)

The GCR Amplitude Sensor routine is identical to that of Test 42 except that the subsystem is placed in GCR mode. This requires the generation of the proper write current levels by the WR write card and amp sensor threshold selection by the RD read card.

8.3.4.3 PE Write Records (48)

The PE Write Records routine performs the first formatted PE write test of the test package. As the DP data path card has been verified by the loop write-to-read tests, this routine detects and isolates faults in the WR write card, RD read card, and read/write head. If any velocity errors occur, both the DP data path card and the SV servo card will be indicated.

256 records are written (16 groups separated by tape marks). Each record contains data representing its tape position. Any reject or machine check that occurs during the writing of a record will be displayed.

8.3.4.4 PE Read Forward (49)

The PE Read Forward routine isolates read failures associated with the RD read card and the read/write head since data transfer from the data path card has been tested with the loop write-to-read tests. Following a rewind, the records written by Test 48 are read forward and the data verified. Any reject or machine check that occurs during the writing of a record will be displayed.

8.3.4.5 PE Read Backward (4A)

The PE Read Backward routine verifies read backward operations using the tape formatted by Test 48. After positioning on the BOT side of the logical end-of-tape (two tape marks), the 256 records are read backward and the data verified. Any reject or machine check that occurs during the reading of a record will be displayed.

8.3.4.6 PE Positioning (4B)

The PE Positioning routine tests the positioning commands (Forward Space File, Backward Space File, Backspace A Block, and Forward Space A Block). Various combinations of these commands are issued expecting the tape formatted by Test 48. Tape position is verified by the data read from the records.

8.3.4.7 GCR Write Records (4C)

The GCR Write Records routine performs the first formatted GCR write of the test package. Failures detected by this test are now limited to the WR write card, RD read card, and the read/write head.

256 records are written (16 groups separated by tape marks). Each record contains data representing its tape position. Any reject or machine check that occurs during the writing of a record will be displayed.

8.3.4.8 GCR Read Forward (4D)

The GCR Read Forward routine isolates read failures associated with the RD read card and the read/write head since the data transfer from the data path has been tested by the loop write-to-read tests. Following a rewind, the records written by Test 4C are read forward and the data verified. Any reject or machine check that occurs during the writing of a record will be displayed at operator panel.

8.3.4.9 GCR Read Backward (4E)

The GCR Read Backward routine verifies read backward operations using the tape formatted by Test 4C. After positioning on the BOT side of the logical end-of-tape (two tape marks), the 256 records are read backward and the data verified. Any reject or machine check that occurs during the reading of a record will be displayed.

8.3.4.10 GCR Positioning (4F)

The GCR Positioning routine tests the positioning commands (Forward Space File, Backward Space File, Backspace A Block, and Forward Space A Block). Various combinations of these commands are issued expecting the tape formatted by Test 4C. Tape position is verified by the data read from the records.

8.4 EXTERNAL DIAGNOSTICS

The External Diagnostics are supplied on a floppy diskette with the standard 1900 diagnostic control monitor. The routine library consists of an interface verification test, an internal diagnostic initiator, and several online exerciser routines (PE and GCR).

Interface verification is performed by the internal manipulation of all status lines following invocation by the 3910 Detached Diagnostic Device. The interface test sets the subsystem in a diagnostic mode which allows the independent activation of each standard interface line. The 3910 verifies that all status line transitions occur. With satisfactory communication ensured, internal diagnostics can be initiated and the test results obtained. All subsystem fault isolation is performed by the internal diagnostics. The remaining online 3910 routines are not intended to isolate any fault conditions within the subsystem, but only to provide a figure of merit for subsystem performance.

APPENDIX A

FAULT CODE DICTIONARY

This dictionary corresponds to given release levels of subsystem microcode. To ascertain the microcode release level, use the following front panel sequence:

<ENTER ADDR>,1FFA,<ENTER>: displays msb of the release level
<ENTER>: displays lsb of the release level

It is important that the user of this dictionary ensures the matching of dictionary text to microcode level. The following table associates microcode EC and release level to dictionary page changes. The latest EC covered by this dictionary is indicated by the last entry of this table or any subsequent EC's which do not indicate a Maintenance Manual Appendix A impact.

EC	Microcode Level	Page(s) Changed
49576	A115	Initial Release
49582	A116	A-66 to A-69
49649	A117	All pages

Code	Detected by	Fault Description--FRU'S
------	----------------	--------------------------

001 TEST00 Drive not loaded before forward motion request.

002 TEST00 EOT status detected before forward motion set.
Card: WR IF
Slot: A4 A3

003 TEST00 EOT detected via sensors during forward motion.
Card: WR IF
Slot: A4 A3

011 TEST01 Drive not loaded before backward motion request.

012 TEST01 BOT status detected before backward motion set.
Card: WR IF
Slot: A4 A3

013 TEST01 BOT detected via sensors during backward motion.
Card: WR IF
Slot: A4 A3

021 TEST02 Drive not loaded before motion request.

022 TEST02 EOT status detected before motion set.
Card: WR IF
Slot: A4 A3

023 TEST02 EOT detected via sensors during forward motion.
Card: WR IF
Slot: A4 A3

031 TEST03 Drive not loaded before motion request.

Code	Detected by	Fault Description--FRU'S
------	----------------	--------------------------

032 TEST03 EOT status detected before motion set.
Card: WR IF
Slot: A4 A3

033 TEST03 BOT or EOT detected during motion via sensors.
Card: WR IF
Slot: A4 A3

091 TEST09 Can not execute maintenance reel/capstan driver
while drive is loaded.

092 TEST09 Tape presence was detected in thread path via
sensors. Can not execute maintenance reel/capstan
driver.
Card: WR IF
Slot: A4 A3

0E1 TEST0E Maintenance write requires drive loaded.

0E2 TEST0E Maintenance write will not run on file protected
tape.

0E3 TEST0E EOT status detected before motion.

0E4 TEST0E EOT detected via sensors during forward motion.

0F1 TEST0F Maintenance write requires drive loaded.

0F2 TEST0F Maintenance write will not run on file protected
tape.

0F3 TEST0F EOT status detected before motion.

Code	Detected by	Fault Description--FRU'S
------	-------------	--------------------------

0F4 TEST0F EOT detected via sensors during forward motion.

121 TEST12 Initial write of memory compared incorrectly while testing functional RAM (A000-A7FF).

Card: 1F
Slot: A3

122 TEST12 Read,write complement,read sequence failed while testing functional RAM (A000-A7FF).

Card: 1F
Slot: A3

123 TEST12 Initial write of memory compared incorrectly while testing diagnostic RAM (8000-87FF).

Card: 1F
Slot: A3

124 TEST12 Read,write complement,read sequence failed while testing diagnostic RAM (8000-87FF).

Card: 1F
Slot: A3

125 TEST12 Checksum incorrect in low PROM (0000-1FFF).

Card: 1F
Slot: A3

126 TEST12 Checksum incorrect in middle PROM (2000-3FFF):

Card: 1F
Slot: A3

127 TEST12 Checksum incorrect in high PROM (4000-5FFF).

Card: 1F
Slot: A3

Code	Detected by	Fault Description--FRU'S
------	-------------	--------------------------

- 128 TEST12 Release level mis-match between proms.
Locations: PROM1 = (1FFA,B)
PROM2 = (3FFA,B)
PROM3 = (5FFA,B)
Card: IF
Slot: A3
- 131 TEST13 Counters were loaded with large timeout values and interrupt controller was initialized. When read before complete count-down of counters the IRR register of the controller was expected to be zero.
Status A-0 = active counter inputs to 8259
(should be 0)
Card: IF KK DP WR SV
Slot: A3 A5 A4 A1
- 132 TEST13 Counters were loaded with counts such that timeouts would be expected in the order 0,1,2. The counter 0 output was the one and only expected at the IRR register of the interrupt controller (8259) at this time.
Status A-0 = active counter inputs to 8259
(should be 01 hex)
Card: IF KK DP WR SV
Slot: A3 A5 A4 A1
- 133 TEST13 Counters were loaded with counts such that timeouts would be expected in the order 0,1,2. Outputs from counters 0 and 1 were the only expected at the IRR register of the interrupt controller (8259) at this time.
Status A-0 = active counter inputs to 8259 .
(should be 21 hex)
Card: IF
Slot: A3

Code	Detected by	Fault Description--FRU'S
------	-------------	--------------------------

- 134 TEST13 Counters were loaded with counts such that timeouts would be expected in the order 0,1,2. Outputs from all 3 counters were expected at the IRR register of the interrupt controller (8259) at this time.
- Status A-0 = active counter inputs to 8259
(should be 61 hex)
- Card: 1F
Slot: A3
- 142 TEST14 Spurious interrupts received by controller.
- Status A-0 = interrupts recv'd
(should be 0)
- Card: 1F
Slot: A3
- 144 TEST14 Interrupts from counters not received correctly.
- Status A-0 = interrupts received
(should be 01H; counter 0 only)
- Card: 1F
Slot: A3
- 146 TEST14 Interrupts from counters not received correctly.
- Status A-0 = interrupts received
(should be 21H; counters 0 & 1)
- Card: 1F
Slot: A3
- 148 TEST14 Interrupts from counters not received correctly.
- Status A-0 = interrupts received
(should be 61H; counters 0,1 & 2)
- Card: 1F
Slot: A3

Code	Detected by	Fault Description--FRU'S
------	-------------	--------------------------

151 TEST15 Multiple keyboard columns active in sense register (6010) for a given row selection (601A).
Check for proper panel cable connection.

Card: IF KK
Slot: A3

153 TEST15 More than one front panel key detected (6010) for different row selections (601A).
Check for proper panel cable connection.

Card: IF KK
Slot: A3

181 TEST18 Position counter (SV card, XCS chip) could not be looped correctly (wrt: 6023; rd: 6025).

Status A-0: expected pattern
Status A-1: actual pattern

Card: IF SV DP WR
Slot: A3 A1 A5 A4

183 TEST18 Velocity register (SV card, XCS chip) could not be looped correctly (wrt: 6026,28,29; rd: 6027).

Status A-0: pattern
Status A-2: should be pattern shifted left once

Card: IF SV DP WR
Slot: A3 A1 A5 A4

185 TEST18 Machine swing arm position (SV card, XRS chip) could not be looped correctly (wrt: 6030,32; rd: 6034).

Status A-0: pattern
Status A-3: should be pattern shifted left twice

Card: IF SV DP WR
Slot: A3 A1 A5 A4

Code	Detected by	Fault Description--FRU'S
------	-------------	--------------------------

- 187 TEST18 File swing arm position (SV card, XRS chip) could not be looped correctly (wrt: 6031,33; rd: 6035).
 Status A-0: pattern
 Status A-4: should be pattern shifted left 3 bits
 Card: IF SV DP WR
 Slot: A3 A1 A5 A4
- 1B1 TEST1B Data path status B (6042) not 0 with resets active.
 Card: DP IF WR SV
 Slot: A5 A3 A4 A1
- 1B3 TEST1B Data path status B (6042) not indicating CRC + CRCA (06h) after resets cleared and GCR mode set.
 Card: DP IF WR SV
 Slot: A5 A3 A4 A1
- 1B4 TEST1B Dead track register (6040) not inactive (FFh) following data path reset.
 Card: DP IF
 Slot: A5 A3
- 1B5 TEST1B Data path status A (6041) not 0 following data path reset.
 Card: DP IF
 Slot: A5 A3
- 1B6 TEST1B Data path status C (6043) not inactive (04h) following data path reset.
 Card: DP IF
 Slot: A5 A3

Code	Detected by	Fault Description--FRU'S
------	-------------	--------------------------

1B7 TEST1B Phase pointer register (6044) not 0 following data path reset.

Card: DP IF
Slot: A5 A3

1B8 TEST1B Amp sensor register (6045) not 0 following data path reset.

Card: DP IF
Slot: A5 A3

1D1 TEST1D Following the disabling of all sensors (6068), only file protect status (6060) should have been active.

Status A-0:* sensor bit(s) in error

Card: WR IF
Slot: A4 A3

Sensor: EOT/BOT, File Protect, Leader

1D2 TEST1D After enabling EOT sensor only (6068), sensor status (6060) was incorrect.

Status A-0: sensor bit(s) in error

Card: WR IF
Slot: A4 A3

Sensor: EOT/BOT, File Protect, Leader

1D3 TEST1D After enabling BOT sensor only (6068), sensor status (6060) was incorrect.

Status A-0: sensor bit(s) in error

Card: WR IF
Slot: A4 A3

Sensor: EOT/BOT, File Protect, Leader

Code	Detected by	Fault Description--FRU'S
------	-------------	--------------------------

104 TEST1D After enabling tape present sensor only (6068), status (6060) was incorrect.

Status A-0: sensor bit(s) in error

Card: WR IF
Slot: A4 A3

Sensor: EOT/BOT, File Protect, Leader

105 TEST1D After enabling leader sensor only (6068), status (6060) was incorrect.

Status A-0: sensor bit(s) in error

Card: WR IF
Slot: A4 A3

Sensor: EOT/BOT, File Protect, Leader

106 TEST1D After enabling file protect sensor only (6068), status (6060) was incorrect.

Status A-0: sensor bit(s) in error

Card: WR IF
Slot: A4 A3

Sensor: EOT/BOT, File Protect, Leader

107 TEST1D After disabling the write/erase currents (6068), current status (6060) should indicate off and stable.

Status A-0: sensor bit(s) in error

Card: WR IF Rd/Wrt head,cable
Slot: A4 A3

Code	Detected by	Fault Description--FRU'S
------	-------------	--------------------------

- 1F1 TEST1F Functional code detected machine check condition during swing arm extend/retract cycle.
- Status A-6: Machine check code
See listing for code Fxx, where
xx= contents of this status location
- 1F2 TEST1F INDEX's from both arm position sensors (6061) were detected when retracting from 'EXTENDED'. However, the FILE arm's upper EPO area ('INDEX' off) was not detected before the MACHINE arm reached 'Retracted'.
- Check FILE arm sensor for 'INDEX' off capability.
Check MACH arm sensor for false 'INDEX'.
- Card: SV WR IF
Slot: A1 A4 A3
- 1F3 TEST1F INDEX's from both arm position sensors (6061) were detected when retracting from 'EXTENDED'. However, the MACHINE arm's upper EPO area ('INDEX' off) was not detected before the FILE arm reached 'Retracted'.
- Check MACH arm sensor for 'INDEX' off capability.
Check FILE arm sensor for false 'INDEX'.
- Card: SV WR IF
Slot: A1 A4 A3
- 1F8 TEST1F Software count of MACHINE arm tachs (6036) was extremely low through the 'INDEX' area. This may indicate inoperable phase A and/or B tach lines.
- Status B-2,B-3: MACH index dist (low, high byte)
Allowed range: 00F0h -> 0108h
- Check MACH arm tach assembly for tach signals.
- Card: SV WR IF
Slot: A1 A4 A3

Code	Detected by	Fault Description--FRU'S
------	-------------	--------------------------

1F9 TEST1F Software count of FILE arm tachs (6036) was extremely low through the 'INDEX' area. This may indicate inoperable phase A and/or B tach lines.

Status B-4,B-5: FILE index dist (low, high byte)
 Allowed range: 00F0h -> 0108h

Check FILE arm tach assembly for tach signals.

Card: SV WR IF
 Slot: A1 A4 A3

1FA TEST1F Software count of MACHINE arm tachs (6036) thru 'INDEX' area was not as expected.

Status B-2,B-3: MACH index dist (low, high byte)
 Allowed range: 00F0h -> 0108h

Card: SV WR IF
 Slot: A1 A4 A3

1FB TEST1F Software count of FILE arm tachs (6036) through 'INDEX' area was not as expected.

Status B-4,B-5: FILE index dist (low, high byte)
 Allowed range: 00F0h -> 0108h

Card: SV WR IF
 Slot: A1 A4 A3

1FC TEST1F Insufficient EPO margin ('EXTENDED' to 'INDEX') was indicated by the MACH arm tach (6036).

Status B-0: MACH epo distance (quarter tachs)
 minimum: 03 hex

Check MACH arm tach assembly.

Card: SV WR IF
 Slot: A1 A4 A3

Code	Detected by	Fault Description--FRU'S
------	-------------	--------------------------

1FD TEST1F Insufficient EPO margin ('EXTENDED' to 'INDEX') was indicated by the FILE arm tach (6036).

Status B-1: FILE epo distance (quarter tachs)
 minimum: 03 hex

Check FILE arm tach assembly.

Card: SV WR 1F
 Slot: A1 A4 A3

1FE TEST1F Software counts of MACHINE arm position tachs were within allowable limits. However, hardware counter (read from 6034 and placed in Status B-6) was not within 10 (decimal) counts of the software count. (Note: only the low byte of software count is used in the compare).

Status B-2,B-3: mach index dist (low, high byte)
 Status B-6: mach index dist (from hardware)

Card: SV WR 1F
 Slot: A1 A4 A3

1FF TEST1F Software counts of FILE arm position tachs were within allowable limits. However, hardware counter (read from 6035 and placed in Status B-7) was not within 10 (decimal) counts of the software count. (Note: only the low byte of software count is used in the compare).

Status B-4,B-5: file index dist (low, high byte)
 Status B-7: file index dist (from hardware)

Card: SV WR 1F
 Slot: A1 A4 A3

Code	Detected by	Fault Description--FRU'S
------	-------------	--------------------------

221 TEST22 Write and/or Read complete (6014) failed to initialize following a reset (601E).

STATUS B-0: patterns in order of execution--

0- FF's to data path

1- 00's to data path

2- AA55 pattern

3- 55AA pattern

4- walking 0 bit

5- walking 1 bit

6- pseudo random (long records)

STATUS B-1: byte count (range: 5 -> 8)

STATUS B-2: byte pointer (walking bit patterns)

STATUS B-3: bit pointer (" " ")

Card: DP IF

Slot: A5 A3

222 TEST22 Attempt to clear data-path-complete interrupt from interrupt controller (8259: IRR reg) failed-- see code 221 for status locations.

Card: DP IF

Slot: A5 A3

223 TEST22 After setting byte count (IF card) and allowing write transfer, write complete did not occur-- see code 221 for status locations.

Card: DP IF

Slot: A5 A3

224 TEST22 Data path complete was returned early; before the expected termination of postamble writing-- see code 221 for status locations.

Card: DP IF

Slot: A5 A3

Code	Detected by	Fault Description--FRU'S
------	-------------	--------------------------

225 TEST22 After issuing read command, setting short reset to data path front end (601D), and allowing data transfer, timeout occurred waiting for read complete--see code 221 for status locations.

Card: DP IF WR
Slot: A5 A3 A4

226 TEST22 After readback of given byte count, data-path-complete interrupt (indicating completion of postamble write) did not occur--see code 221 for status locations.

Card: DP RD IF WR
Slot: A5 A6 A3 A4

227 TEST22 Parity was incorrect (6014) following completion of readback--see code 221 for status locations.

Card: DP IF
Slot: A5 A3

22A TEST22 Following completion of write and read portions of the loop-write-read, DPSTATA (6041) was not as expected (00h or 01h)--see code 221 for status locations.

Card: DP RD WR IF
Slot: A5 A6 A4 A3

22B TEST22 Following completion of write and read portions of the loop-write-read, DPSTATB (6042) was not as expected (00h or 02h)--see code 221 for status locations.

Card: DP RD WR IF
Slot: A5 A6 A4 A3

Code	Detected by	Fault Description--FRU'S
------	-------------	--------------------------

22C TEST22 Following completion of write and read portions of the loop-write-read, DPSTATC (6043) was not as expected (00h -> 07h)--see code 221 for status locations.

Card: DP RD WR IF
Slot: A5 A6 A4 A3

22F TEST22 Following completion of write and read portions of the loop-write-read without detectable errors, write and read buffer data miscompared--see code 221 for status locations.

Card: DP IF
Slot: A5 A3

231 TEST23 Data path "Status A" (6041) not indicating velocity error only (02 hex) following a "loop-write-to-read" record written at 12.5% high velocity.

STATUS A-0: failing status bits

Card: DP IF
Slot: A5 A3

232 TEST23 Data path "Status A" (6041) not zero following a "loop-write-to-read" record written at 5.6% high velocity.

Card: DP IF
Slot: A5 A3

233 TEST23 Data path "Status A" (6041) not zero following a "loop-write-to-read" record written at 8.2% low velocity.

Card: DP IF
Slot: A5 A3

Code	Detected by	Fault Description--FRU'S
------	-------------	--------------------------

234 TEST23 Data path "Status A" (6041) not indicating velocity error only (02 hex) following a "loop-write-to-read" record written at 15.1% low velocity.

STATUS A-0: failing status bits

Card: DP 1F
Slot: A5 A3

241 TEST24 Write and/or Read complete (6014) failed to initialize following a reset (601E).

STATUS B-0: patterns in order of execution--

- 0- FF's to data path
- 1- 00's to data path
- 2- AA55 pattern
- 3- 55AA pattern
- 4- walking 0 bit
- 5- walking 1 bit
- 6- pseudo random (long records)

STATUS B-1: byte count (range: 1 -> 6)
STATUS B-2: byte pointer (walking bit patterns)
STATUS B-3: bit pointer (" " ")

Card: DP 1F
Slot: A5 A3

242 TEST24 Attempt to clear data-path-complete interrupt from interrupt controller (8259: IRR reg) failed-- see code 241 for status locations.

Card: DP 1F
Slot: A5 A3

243 TEST24 After setting byte count (1F card) and allowing write transfer, write complete did not occur-- see code 241 for status locations.

Card: DP 1F
Slot: A5 A3

Code	Detected by	Fault Description--FRU'S
------	-------------	--------------------------

244 TEST24 Data path complete was returned early; before the expected termination of postamble writing--see code 241 for status locations.

Card: DP IF
Slot: A5 A3

245 TEST24 After issuing read command, setting short reset to data path front end (601D), and allowing data transfer, timeout occurred waiting for read complete--see code 241 for status locations.

Card: DP IF
Slot: A5 A3

246 TEST24 After readback of given byte count, data-path-complete interrupt (indicating completion of postamble write) did not occur--see code 241 for status locations.

Card: DP RD IF WR
Slot: A5 A6 A3 A4

247 TEST24 Parity was incorrect (6014) following completion of readback--see code 241 for status locations.

Card: DP IF
Slot: A5 A3

24A TEST24 Following completion of write and read portions of the loop-write-read, DPSTATA (6041) was not as expected (00h or 01h)--see code 241 for status locations.

Card: DP RD WR IF
Slot: A5 A6 A4 A3

Code	Detected by	Fault Description--FRU'S
------	-------------	--------------------------

- 24B TEST24 Following completion of write and read portions of the loop-write-read, DPSTATB (6042) was not as expected (00h or 08h)--see code 241 for status locations.
- Card: DP RD WR IF
Slot: A5 A6 A4 A3
- 24C TEST24 Following completion of write and read portions of the loop-write-read, DPSTATC (6043) was not as expected (00h -> 07h)--see code 241 for status locations.
- Card: DP RD WR IF
Slot: A5 A6 A4 A3
- 24F TEST24 Following completion of write and read portions of the loop-write-read without detectable errors, write and read buffer data miscompared--see code 241 for status locations.
- Card: DP IF
Slot: A5 A3
- 251 TEST25 Data path "Status A" (6041) not indicating velocity error only (02 hex) following a "loop-write-to-read" record written at 12.5% high velocity.
- STATUS A-0: failing status bits
- Card: DP IF
Slot: A5 A3
- 252 TEST25 Data path "Status A" (6041) not zero following a "loop-write-to-read" record written at 5.6% high velocity.
- Card: DP IF
Slot: A5 A3

Code	Detected by	Fault Description--FRU'S
------	-------------	--------------------------

- 253 TEST25 Data path "Status A" (6041) not zero following a "loop-write-to-read" record written at 8.2% low velocity.
- Card: DP IF
Slot: A5 A3
- 254 TEST25 Data path "Status A" (6041) not indicating velocity error only (02 hex) following a "loop-write-to-read" record written at 15.1% low velocity.
- STATUS A-0: failing status bits
- Card: DP IF
Slot: A5 A3
- 261 TEST26 Write and/or Read complete (6014) failed to initialize following a reset (601E).
- STATUS C-0: dead tracks (tracks 0-7, initially 01)
STATUS C-1: dead tracks (track P, initially 00)
- STATUS B-0: patterns in order of execution--
4- walking 0 bit
6- pseudo random (long records)
- STATUS B-1: byte count (8 bytes for pattern 4)
STATUS B-2: byte pointer (walking bit patterns)
STATUS B-3: bit pointer (" " ")
- Card: DP IF
Slot: A5 A3
- 262 TEST26 Attempt to clear data-path-complete interrupt from interrupt controller (8259: IRR reg) failed-- see code 261 for status locations.
- Card: DP IF
Slot: A5 A3

Code	Detected by	Fault Description--FRU'S
------	-------------	--------------------------

263 TEST26 After setting byte count (IF card) and allowing write transfer, write complete did not occur--see code 261 for status locations.

Card: DP IF
Slot: A5 A3

264 TEST26 Data path complete was returned early; before the expected termination of postamble writing--see code 261 for status locations.

Card: DP IF
Slot: A5 A3

265 TEST26 After issuing read command, setting short reset to data path front end (601D), and allowing data transfer, timeout occurred waiting for read complete--see code 261 for status locations.

Card: DP IF
Slot: A5 A3

266 TEST26 After readback of given byte count, data-path-complete interrupt (indicating completion of postamble write) did not occur--see code 261 for status locations.

Card: DP RD IF WR
Slot: A5 A6 A3 A4

267 TEST26 Parity was incorrect (6014) following completion of readback--see code 261 for status locations.

Card: DP IF
Slot: A5 A3

Code	Detected by	Fault Description--FRU'S
------	-------------	--------------------------

26A TEST26 Following completion of write and read portions of the loop-write-read, DPSTATA (6041) was not as expected (08h or 09h)--see code 261 for status locations.

Card: DP RD WR IF
Slot: A5 A6 A4 A3

26B TEST26 Following completion of write and read portions of the loop-write-read, DPSTATB (6042) was not as expected (00h or 02h)--see code 261 for status locations.

Card: DP RD WR IF
Slot: A5 A6 A4 A3

26C TEST26 Following completion of write and read portions of the loop-write-read, DPSTATC (6043) was not as expected (00h -> 07h)--see code 261 for status locations.

Card: DP RD WR IF
Slot: A5 A6 A4 A3

26F TEST26 Following completion of write and read portions of the loop-write-read without detectable errors, write and read buffer data miscompared--see code 261 for status locations.

Card: DP IF
Slot: A5 A3

Code	Detected by	Fault Description--FRU'S
------	-------------	--------------------------

- 271 TEST27 Write and/or Read complete (6014) failed to initialize following a reset (601E).
- STATUS C-0: dead tracks (tracks 0-7, initially 01)
STATUS C-1: dead tracks (track P, initially 00)
- STATUS B-0: patterns in order of execution--
4- walking 0 bit
6- pseudo random (long records)
- STATUS B-1: byte count (6 bytes for pattern 4)
STATUS B-2: byte pointer (walking bit patterns)
STATUS B-3: bit pointer (" " ")
- Card: DP IF
Slot: A5 A3
- 272 TEST27 Attempt to clear data-path-complete interrupt from interrupt controller (8259: IRR reg) failed-- see code 271 for status locations.
- Card: DP IF
Slot: A5 A3
- 273 TEST27 After setting byte count (IF card) and allowing write transfer, write complete did not occur-- see code 271 for status locations.
- Card: DP IF
Slot: A5 A3
- 274 TEST27 Data path complete was returned early; before the expected termination of postamble writing-- see code 271 for status locations.
- Card: DP IF
Slot: A5 A3

Code	Detected by	Fault Description--FRU'S
------	-------------	--------------------------

275 TEST27 After issuing read command, setting short reset to data path front end (601D), and allowing data transfer, timeout occurred waiting for read complete--see code 271 for status locations.

Card: DP IF
Slot: A5 A3

276 TEST27 After readback of given byte count, data-path-complete interrupt (indicating completion of postamble write) did not occur--see code 271 for status locations.

Card: DP RD IF WR
Slot: A5 A6 A3 A4

277 TEST27 Parity was incorrect (6014) following completion of readback--see code 271 for status locations.

Card: DP IF
Slot: A5 A3

27A TEST27 Following completion of write and read portions of the loop-write-read, DPSTATA (6041) was not as expected (08h or 09h)--see code 271 for status locations.

Card: DP RD WR IF
Slot: A5 A6 A4 A3

27B TEST27 Following completion of write and read portions of the loop-write-read, DPSTATB (6042) was not as expected (00h or 08h)--see code 271 for status locations.

Card: DP RD WR IF
Slot: A5 A6 A4 A3

Code	Detected by	Fault Description--FRU'S
------	-------------	--------------------------

27C TEST27 Following completion of write and read portions of the loop-write-read, DPSTATC (6043) was not as expected (00h -> 07h)--see code 271 for status locations.

Card: DP RD WR IF
Slot: A5 A6 A4 A3

27F TEST27 Following completion of write and read portions of the loop-write-read without detectable errors, write and read buffer data miscompared--see code 271 for status locations.

Card: DP IF
Slot: A5 A3

281 TEST28 Write and/or Read complete (6014) failed to initialize following a reset (601E).

STATUS C-0: dead tracks (tracks 0-7, initially 03)
STATUS C-1: dead tracks (track P, initially 00)

STATUS B-0: patterns in order of execution--
4- walking 0 bit
6- pseudo random (long records)

STATUS B-1: byte count (8 bytes for pattern 4)
STATUS B-2: byte pointer (walking bit patterns)
STATUS B-3: bit pointer (" " ")

Card: DP IF
Slot: A5 A3

282 TEST28 Attempt to clear data-path-complete interrupt from interrupt controller (8259: IRR reg) failed--see code 281 for status locations.

Card: DP IF
Slot: A5 A3

Code	Detected by	Fault Description--FRU'S
------	-------------	--------------------------

283 TEST28 After setting byte count (IF card) and allowing write transfer, write complete did not occur--see code 281 for status locations.

Card: DP IF
Slot: A5 A3

284 TEST28 Data path complete was returned early; before the expected termination of postamble writing--see code 281 for status locations.

Card: DP IF
Slot: A5 A3

285 TEST28 After issuing read command, setting short reset to data path front end (601D), and allowing data transfer, timeout occurred waiting for read complete--see code 281 for status locations.

Card: DP IF
Slot: A5 A3

286 TEST28 After readback of given byte count, data-path-complete interrupt (indicating completion of postamble write) did not occur--see code 281 for status locations.

Card: DP RD IF WR
Slot: A5 A6 A3 A4

28A TEST28 Following completion of write and read portions of the loop-write-read, DPSTATA (6041) was not as expected (74h; 09h bits don't care)--see code 281 for status locations.

Card: DP RD WR IF
Slot: A5 A6 A4 A3

Code	Detected by	Fault Description--FRU'S
------	-------------	--------------------------

28B TEST28 Following completion of write and read portions of the loop-write-read, DPSTATB (6042) was not as expected (00h; 0Bh bits don't care)--see code 281 for status locations.

Card: DP RD WR IF
Slot: A5 A6 A4 A3

28C TEST28 Following completion of write and read portions of the loop-write-read, DPSTATC (6043) was not as expected (00h -> 07h)--see code 281 for status locations.

Card: DP RD WR IF
Slot: A5 A6 A4 A3

28D TEST28 CRC-C and BUPER did not both set in DPSTATB (6042) at some time during multi-track error PE loop-write to read testing.

Card: DP IF
Slot: A5 A3

291 TEST29 Write and/or Read complete (6014) failed to initialize following a reset (601E).

STATUS C-0: dead tracks (tracks 0-7, initially 03)
STATUS C-1: dead tracks (track P, initially 00)

STATUS B-0: patterns in order of execution--
4- walking 0 bit
6- pseudo random (long records)

STATUS B-1: byte count (6 bytes for pattern 4)
STATUS B-2: byte pointer (walking bit patterns)
STATUS B-3: bit pointer (" " ")

Card: DP IF
Slot: A5 A3

Code	Detected by	Fault Description--FRU'S
------	-------------	--------------------------

292 TEST29 Attempt to clear data-path-complete interrupt from interrupt controller (8259: IRR reg) failed--see code 291 for status locations.

Card: DP IF
Slot: A5 A3

293 TEST29 After setting byte count (IF card) and allowing write transfer, write complete did not occur--see code 291 for status locations.

Card: DP IF
Slot: A5 A3

294 TEST29 Data path complete was returned early; before the expected termination of postamble writing--see code 291 for status locations.

Card: DP IF
Slot: A5 A3

295 TEST29 After issuing read command, setting short reset to data path front end (601D), and allowing data transfer, timeout occurred waiting for read complete--see code 291 for status locations.

Card: DP IF
Slot: A5 A3

296 TEST29 After readback of given byte count, data-path-complete interrupt (indicating completion of postamble write) did not occur--see code 291 for status locations.

Card: DP RD IF WR
Slot: A5 A6 A3 A4

297 TEST29 Parity was incorrect (6014) following completion of readback--see code 291 for status locations.

Card: DP IF
Slot: A5 A3

Code	Detected by	Fault Description--FRU'S
------	-------------	--------------------------

- 29A TEST29 Following completion of write and read portions of the loop-write-read, DPSTATA (6041) was not as expected (10h,11h,18h, or 19h)--see code 291 for status locations.
- Card: DP RD WR IF
Slot: A5 A6 A4 A3
- 29B TEST29 Following completion of write and read portions of the loop-write-read, DPSTATB (6042) was not as expected (00h or 08h)--see code 291 for status locations.
- Card: DP RD WR IF
Slot: A5 A6 A4 A3
- 29C TEST29 Following completion of write and read portions of the loop-write-read, DPSTATC (6043) was not as expected (00h -> 07h)--see code 291 for status locations.
- Card: DP RD WR IF
Slot: A5 A6 A4 A3
- 29F TEST29 Following completion of write and read portions of the loop-write-read without detectable errors, write and read buffer data miscompared--see code 291 for status locations.
- Card: DP IF
Slot: A5 A3
- 321 TEST32 While in EPO'd state and driving both machine and file DAC's (SV) through drive range (7Fh to 80h), current mode feedback indicated multiple null points.
- Status A-0: first negative drive feedback (mach)
Status A-1: first negative drive feedback (file)
- Card: SV IF EPO Relay
Slot: A1 A3 MBD

Code	Detected by	Fault Description--FRU'S
------	-------------	--------------------------

322 TEST32 Machine/File reel current mode feedback (6050)
indicated null points outside range: FOh <-> 0Fh.

Status A-0: machine reel null
Status A-1: file reel null

Card: SV 1F
Slot: A1 A3

323 TEST32 With EPO reset (current driven thru reels) and
DAC drive applied, initial current mode feedback
(-pump up/down) was incorrect. This is represented
by a FF byte in any of the following status...

Status B-0: MACH reel current time, DAC = 7F
Status B-1: MACH reel current time, DAC = 40
Status B-2: MACH reel current time, DAC = 20
Status B-3: MACH reel current time, DAC = 10
Status B-4: MACH reel current time, DAC = EF
Status B-5: MACH reel current time, DAC = DF
Status B-6: MACH reel current time, DAC = BF
Status B-7: MACH reel current time, DAC = 80

Status B-8: FILE reel current time, DAC = 7F
Status B-9: FILE reel current time, DAC = 40
Status B-A: FILE reel current time, DAC = 20
Status B-B: FILE reel current time, DAC = 10
Status B-C: FILE reel current time, DAC = EF
Status B-D: FILE reel current time, DAC = DF
Status B-E: FILE reel current time, DAC = BF
Status B-F: FILE reel current time, DAC = 80

Card: SV 1F
Slot: A1 A3

Code	Detected by	Fault Description--FRU'S
------	-------------	--------------------------

324 TEST32 With EPO reset (current driven thru MACHINE reel), current feedback was not detected. The timeout for this feedback is indicated by a FE in any of..

Status B-0: MACH reel current time, DAC = 7F
 Status B-1: MACH reel current time, DAC = 40
 Status B-2: MACH reel current time, DAC = 20
 Status B-3: MACH reel current time, DAC = 10
 Status B-4: MACH reel current time, DAC = EF
 Status B-5: MACH reel current time, DAC = DF
 Status B-6: MACH reel current time, DAC = BF
 Status B-7: MACH reel current time, DAC = 80

Check MACHINE reel motor cabling.

Card: SV IF Machine Reel EPO Relay
 Slot: A1 A3 Motor MBD

325 TEST32 With EPO reset (current driven thru FILE reel), current feedback was not detected. The timeout for this feedback is indicated by a FE in any of..

Status B-8: FILE reel current time, DAC = 7F
 Status B-9: FILE reel current time, DAC = 40
 Status B-A: FILE reel current time, DAC = 20
 Status B-B: FILE reel current time, DAC = 10
 Status B-C: FILE reel current time, DAC = EF
 Status B-D: FILE reel current time, DAC = DF
 Status B-E: FILE reel current time, DAC = BF
 Status B-F: FILE reel current time, DAC = 80

Check FILE reel motor cabling.

Card: SV File Reel EPO Relay
 Slot: A1 Motor MBD

326 TEST32 In current mode, the two reel DAC's were each driven through 8 levels: most positive to most negative. The resulting current feedback times did not follow the relative level of drive.

Card: SV
 Slot: A1

Code	Detected by	Fault Description--FRU'S
------	-------------	--------------------------

327 TEST32 The feedback time of MACHINE or FILE reel current was not reduced by a power supply switch to the higher rewind voltage. The expected ratio:

Normal/Rewind > 1.125

Status B-0: Normal-V feedback (Machine)

Status C-0: Rewind-V feedback (Machine)

Status B-8: Normal-V feedback (File)

Status C-8: Rewind-V feedback (File)

Card: SV AK

Slot: A1 Pwr Supply

328 TEST32 In threading mode (voltage feedback), each reel DAC was driven to a forward (08h) and a backward (F7h) level. The "-Pump Up (Down)" signals were not as expected. (In the following status, FF indicates both Up & Down signals were active; FE indicates Up or Down was active longer than 1.5 ms).

Status A-8: Machine reel accel time (Fwd)

Status A-9: Machine reel accel time (Bkwd)

Status A-A: File reel accel time (Fwd)

Status A-B: File reel accel time (Bkwd)

Card: SV

Slot: A1

329 TEST32 In threading mode (voltage feedback), each reel DAC was driven to a forward (08h) and a backward (F7h) level. Motion of the MACHINE reel was not detected (this is indicated by a FD in the status below).

Status A-8: Machine reel accel time (Fwd)

Status A-9: Machine reel accel time (Bkwd)

Card: SV Machine reel

Slot: A1 Motor

Code	Detected by	Fault Description--FRU'S
------	-------------	--------------------------

32A TEST32 In threading mode (voltage feedback), each reel DAC was driven to a forward (08h) and a backward (F7h) level. Motion of the FILE reel was not detected (this is indicated by a FD in the status below).

Status A-A: File reel accel time (Fwd)
 Status A-B: File reel accel time (Bkwd)

Card: SV File reel
 Slot: A1 Motor

32B TEST32 No detectable capstan motion after 4 ms drive pulse applied (maximum positive drive).

Card: SV Capstan/Tach EPO Relay
 Slot: A1 Motor MBD

32C TEST32 In processor controlled mode, the capstan DAC was loaded to generate 4 ms pulses of varying magnitude. The resulting capstan positions did not indicate displacement relative to the drive magnitude.

Status B-0: Capstan distance, DAC = 7F (max pos)
 Status B-1: Capstan distance, DAC = 40
 Status B-2: Capstan distance, DAC = 20
 Status B-3: Capstan distance, DAC = 10
 Status B-4: Capstan distance, DAC = EF
 Status B-5: Capstan distance, DAC = DF
 Status B-6: Capstan distance, DAC = BF
 Status B-7: Capstan distance, DAC = 80 (max neg)

Card: SV Capstan/Tach
 Slot: A1 Motor

32D TEST32 Capstan position count (6024,25) not indicating 50 ips change rate within 100 milli-seconds.

Card: SV Capstan/Tach
 Slot: A1 Motor

Code	Detected by	Fault Description--FRU'S
------	-------------	--------------------------

32E TEST32 After successfully ramping capstan to 50 ips (verified by position counter: 6025) velocity control mode was enabled. Tach-A at diagnostic sense register (6050) was inactive or period was more than 50% over nominal sometime during the check of 1000 tach lines (one revolution).

Card: SV Capstan/Tach
Slot: A1 Motor

32F TEST32 After successfully ramping capstan to 50 ips (verified by position counter: 6025) velocity control mode was enabled. Velocity error (6027) was monitored for a complete revolution of the capstan. Low and high velocities did not meet test requirements:

Allowed range

Status C-0: Low velocity FAh -> 0Eh
Status C-1: High velocity FEh -> 12h

Card: SV Capstan/Tach
Slot: A1 Motor

331 TEST32 Machine check occurred during the initial unload operation.

Status A-6: Machine check code
See description for code Fxx, where
xx= contents of this status location

332 TEST32 Following successful reel and capstan servo testing, a load operation resulted in a machine check.

Status A-6: Machine check code
See description for code Fxx, where
xx= contents of this status location

333 TEST32 Load task did not complete due to non-machine check interrupt (door open, undefined NMI, etc.).

Card: SV IF WR EOT/BOT
Slot: A1 A3 A4 Sensor

Code	Detected by	Fault Description--FRU'S
------	-------------	--------------------------

- 334 TEST32 Door open detected during test.
 Card: SV IF
 Slot: A1 A3
- 341 TEST34 Drive must be loaded.
- 342 TEST34 EOT status detected.
- 343 TEST34 Machine check occurred during wait for stable turn around conditions.
 Status A-1: motion number (01h -> 20h: fwd)
 (21h -> 3Fh: bkwd)
 Status A-6: Machine check code
 See description for code Fxx, where
 xx= contents of this status location
- 345 TEST34 Machine check occurred during acceleration phase of test.
 See status and FRU information for code 343.
- 346 TEST34 Machine check occurred during sustained velocity phase of test.
 See status and FRU information for code 343.
- 347 TEST34 Machine check occurred during deceleration phase of test.
 See status and FRU information for code 343.
- 348 TEST34 Machine check occurred during stop-lock phase of test.
 See status and FRU information for code 343.

Code	Detected by	Fault Description--FRU'S
------	-------------	--------------------------

34A TEST34 Acceleration characteristics were not within spec.
Check for excessive tape path drag.

Status A-1: motion number (01h -> 20h: fwd)
(21h -> 3Fh: bkwd)

parameter:	should be:
------------	------------

Status B-0: Cumulative ramp error	DDh -> 23h
Status B-1: Feed-forward term	08h -> 28h

Card: SV Capstan/Tach
Slot: A1 Motor

34B TEST34 Arm position did not reach zero-error (+/- 5)
within required time on long forward or bkwd motion.
If time is greater than upper limit this could
indicate tape slip (clean capstan wheel).

Status A-1: motion number (01h= 1st fwd)
(21h= 1st bkwd)

parameter:	should be:
------------	------------

Status B-2: Mach arm recovery time	00h -> C8h
Status B-3: File arm recovery time	00h -> C8h

Card: SV Capstan/Tach
Slot: A1 Motor

34C TEST34 Sustained velocity characteristics not within spec.

Status A-1: motion number (01h -> 20h: fwd)
(21h -> 3Fh: bkwd)

parameter:	should be:
------------	------------

Status B-4: Low velocity	EDh -> 13h
Status B-5: High velocity	EDh -> 13h
Status B-6: Feed-forward term	F4h -> 14h

Card: SV Capstan/Tach
Slot: A1 Motor

Code	Detected by	Fault Description--FRU'S
------	-------------	--------------------------

34D TEST34 Deceleration characteristics not within spec.

Status A-1: motion number (01h -> 20h: fwd)
(21h -> 3Fh: bkwd)

parameter:	should be:
------------	------------

Status B-7: Cumulative ramp error	E5h -> 1Bh
Status B-8: Feed-forward term	E8h -> F8h

Card: SV Capstan/Tach
Slot: A1 Motor

34E TEST34 Stop-lock positioning outside limits.

Status A-1: motion number (01h -> 20h: fwd)
(21h -> 3Fh: bkwd)

parameter:	should be:
------------	------------

Status B-A: Low position	F6h -> 0Ah
Status B-B: High position	F6h -> 0Ah

Card: SV Capstan/Tach
Slot: A1 Motor

361 TEST36 Drive must be loaded.

362 TEST36 Machine check occurred during fwd motion (50 ips).

Status A-6: Machine check code
See description for code Fxx, where
xx= contents of this status location

Check power supply voltages (AK card).

363 TEST36 Machine check occurred during velocity ramp up
from 50 to 170 ips.
See status and FRU information for code 362.

Code	Detected by	Fault Description--FRU'S
------	-------------	--------------------------

- 364 TEST36 Machine check occurred during attempted velocity ramp up from 170 to 220 ips.
See status and FRU information for code 362.
- 365 TEST36 Following BOT detection during rewind, a machine check occurred during the ramp down from approx 220 ips to 50 ips.
See status and FRU information for code 362.
- 366 TEST36 Immediately after rewind ramp down at BOT, a machine check occurred during the settling time.
See status and FRU information for code 362.
- 367 TEST36 Machine check occurred during turn around operation.
See status and FRU information for code 362.
- 368 TEST36 Maximum velocity attained during 125 foot rewind was less than 175 ips (OCAh).

Status B-0: maximum velocity (VL-VR)

Card: SV AK
Slot: A1 Pwr Supply
- 421 TEST42 Drive must be loaded
- 422 TEST42 Tape must be write enabled
- 423 TEST42 Reject or Machine check from initial rewind.
See description of reject codes preceeding code E01.
- 424 TEST42 Current on or unstable (6061) afer rewind.

Card: WR IF RD
Slot: A4 A3 A6

Code	Detected by	Fault Description--FRU'S
------	-------------	--------------------------

- 425 TEST42 Immediately after setting erase, status was in error (6061).
 Card: WR IF RD
 Slot: A4 A3 A6
- 426 TEST42 Interrupt from erase transition was not seen.
 Card: WR IF
 Slot: A4 A3
- 427 TEST42 Stable erase-only status was not seen in sense register (6061).
 Card: WR IF Write/Erase head
 Slot: A4 A3
- 428 TEST42 Stable write mode status was not seen in sense register (6061).
 Card: WR IF Write/Erase head
 Slot: A4 A3
- 42A TEST42 Amplitude sensor active without motion (6045 or 6043).
 Card: WR IF DP
 Slot: A4 A3 A5
- 42B TEST42 Machine check occurred during forward write motion.
 Status A-6: Machine check code
 See description for code Fxx, where
 xx= contents of this status location

Code	Detected by	Fault Description--FRU'S
------	-------------	--------------------------

42C TEST42 Amplitude sensor not as expected during 30 foot all track write.

Check tape quality.

Status B-0,7: error count for tracks 0,7
 Status B-8: error count for tracks P

Card: WR RD DP Rd/Wrt
 Slot: A4 A6 A5 Head

42D TEST42 Amplitude sensor not as expected during 1 foot write of one track only.

Check tape quality.

Status B-0,7: error count for tracks 0,7
 Status B-8: error count for tracks P

Card: WR RD DP Rd/Wrt
 Slot: A4 A6 A5 Head

42E TEST42 Amplitude sensor not as expected during 1 foot write of all but one track.

Check tape quality.

Status B-0,7: error count for tracks 0,7
 Status B-8: error count for tracks P

Card: WR RD DP Rd/Wrt
 Slot: A4 A6 A5 Head

42F TEST42 Amplitude sensor detected during feed-through check (all tracks writing; no motion).

Status B-0,7: error count for tracks 0,7
 Status B-8: error count for tracks P

Card: WR RD DP Rd/Wrt
 Slot: A4 A6 A5 Head

431 TEST43 Drive must be loaded

Code	Detected by	Fault Description--FRU'S
------	-------------	--------------------------

- 432 TEST43 Tape must be write enabled
- 433 TEST43 Reject or Machine check from initial rewind.
See description of reject codes preceeding code E01.
- 434 TEST43 Current on or unstable (6061) afer rewind.

Card: WR IF RD
Slot: A4 A3 A6
- 435 TEST43 Immediately after setting erase, status was in error (6061).

Card: WR IF RD
Slot: A4 A3 A6
- 436 TEST43 Interrupt from erase transition was not seen.

Card: WR IF
Slot: A4 A3
- 437 TEST43 Stable erase-only status was not seen in sense register (6061).

Card: WR IF Rd/Wrt
Slot: A4 A3 Head
- 438 TEST43 Stable write mode status was not seen in sense register (6061).

Card: WR IF Rd/Wrt
Slot: A4 A3 Head
- 43A TEST43 Amplitude sensor active without motion (6045 or 6043).

Card: WR IF DP
Slot: A4 A3 A5

Code	Detected by	Fault Description--FRU'S
------	-------------	--------------------------

43B TEST43 Machine check occurred during forward write motion.

Status A-6: Machine check code
 See description for code Fxx, where
 xx= contents of this status location

43C TEST43 Amplitude sensor not as expected during 30 foot
 all track write.

Check tape quality.

Status B-0,7: error count for tracks 0,7
 Status B-8: error count for tracks P

Card: WR RD DP Rd/Wrt
 Slot: A4 A6 A5 Head

43D TEST43 Amplitude sensor not as expected during 1 foot
 write of one track only.

Check tape quality.

Status B-0,7: error count for tracks 0,7
 Status B-8: error count for tracks P

Card: WR RD DP Rd/Wrt
 Slot: A4 A6 A5 Head

43E TEST43 Amplitude sensor not as expected during 1 foot
 write of all but one track.

Check tape quality.

Status B-0,7: error count for tracks 0,7
 Status B-8: error count for tracks P

Card: WR RD DP Rd/Wrt
 Slot: A4 A6 A5 Head

Code	Detected by	Fault Description--FRU'S
------	-------------	--------------------------

- 43F TEST43 Amplitude sensor detected during feed-through check (all tracks writing; no motion).
 Status B-0,7: error count for tracks 0,7
 Status B-8: error count for tracks P
 Card: WR RD DP Rd/Wrt
 Slot: A4 A6 A5 Head
- 481 TEST48 Drive must be loaded
- 482 TEST48 Tape must be write enabled
- 483 TEST48 Reject or Machine check from initial rewind.
 See description of reject codes preceding code E01.
- 484 TEST48 Reject or Machine check from internal write command.
 Status A-0,A-1: Low, high byte of record number.
 Range: 000-100 hex.
 See description of reject codes preceding code E01.
- 485 TEST48 Write overrun status (6042) during internal write (data supplied to DP from IF card only).
 Status A-0,A-1: Low, high byte of record number.
 Range: 000-100 hex.
 Card: IF DP
 Slot: A3 A5
- 486 TEST48 Bus parity error status (6042) during internal write (data supplied to DP from IF card only).
 Status A-0,A-1: Low, high byte of record number.
 (Range: 000-100 hex)
 Card: IF DP
 Slot: A3 A5

Code	Detected by	Fault Description--FRU'S
------	-------------	--------------------------

488 TEST48 Reject or Machine check from back-space-block or erase-gap command during write error recovery. See description of reject codes preceding code E01.

489 TEST48 During write error recovery, all 5 retries failed.
 Status A-0,A-1: Low, high byte of record number.
 (Range: 000-100 hex)

Check tape quality.

Card: DP WR RD IF
 Slot: A5 A4 A6 A3

48A TEST48 Reject or Machine check from write-tape-mark command.
 Status A-0,A-1: Low, high byte of record number
 (first WTM occurs at 10 hex)
 See description of reject codes preceding code E01.

48B TEST48 During the writing of 256 PE records, more than one temporary write error occurred.
 Status A-2: Total failing writes
 Status A-3: Temporary write errors
 (1 data check in 6 attempts)
 Status A-4: Media defects
 (>1 data check in 6 attempts)

** Read/Write Error Tallies **

Status A-8: Data checks Status A-C: Multi-trks
 Status A-9: Velocity Status A-D: Part. recd's
 Status A-A: End Data Chks Status A-E: Un-corr.
 Status A-B: Corrections Status A-F: CRC errors

Status B-0 -> B-8: Dead Track counters 0-7,P
 Status C-0 -> C-8: Phase error counters 0-7,P

Card: DP WR RD IF
 Slot: A5 A4 A6 A3

Code	Detected by	Fault Description--FRU'S
------	-------------	--------------------------

- 491 TEST49 Drive must be loaded
- 492 TEST49 Reject or machine check from initial rewind.
See description of reject codes preceeding code E01.
- 493 TEST49 Reject or Machine check from internal read forward.
See description of reject codes preceeding code E01.
- 496 TEST49 Unexpected tape mark (did not follow a 16 record group). Tape must have been written by TEST48.

Status A-0,A-1: Low, high byte of record number
(Range: 000-100 hex)

Card: DP
Slot: A5
- 497 TEST49 Unexpected tape mark (more than 256 records read correctly, but tape mark did not follow 16 record group). Tape must have been written by TEST48.

Status A-0,A-1: Low, high byte of record number
(Range: 000-100 hex)

Card: DP
Slot: A5
- 499 TEST49 Data miscompare following read without data check (tape must have been written by TEST48). Comparison involved 32 bytes of write buffer (8000-801F) and 32 bytes of read buffer (8020-803F). Data should match record number below:

Status A-0,A-1: Low, high byte of record number
(Range: 000-100 hex)

Card: DP RD IF
Slot: A5 A6 A3

Code	Detected by	Fault Description--FRU'S
------	-------------	--------------------------

49B TEST49 Reject or Machine check from internal read forward over expected tape mark.

Status A-0,A-1: Low, high byte of record number
(Range: 000-100 hex)

Status A-5: Reject code (nn)
See code description: Enn

If nn = 11 (reject code for machine chk):

Status A-6: Machine check code (mm)
See code description: Fmm

49C TEST49 Tape mark status not detected when expected (but 16 record group read OK).

Status A-0,A-1: Low, high byte of record number
(Range: 000-100 hex, first TMK @ 10)

Card: DP
Slot: A5

49E TEST49 Failed internal record read with 5 retries.

Status A-0,A-1: Low, high byte of record number
(Range: 000-100 hex)

** Read/Write Error Tallies **

Status A-8: Data checks Status A-C: Multi-trks
Status A-9: Velocity Status A-D: Part. recd's
Status A-A: End Data Chks Status A-E: Un-corr.
Status A-B: Corrections Status A-F: CRC errors

Status B-0 -> B-8: Dead track counters 0-7, P
Status C-0 -> C-8: Phase error counters 0-7, P

Card: DP
Slot: A5

49F TEST49 Reject or Machine check from internal Back-Space-Block command during read error recovery.
See description of reject codes preceeding code E01.

Code	Detected by	Fault Description--FRU'S
------	-------------	--------------------------

- 4A1 TEST4A Drive not loaded
- 4A2 TEST4A Reject or Machine check from internal read backward operation (searching for EOF tape marks). See description of reject codes preceding code E01.
- 4A3 TEST4A Reject or Machine check from internal read forward operations (searching for EOF tape marks) or read backward operations (if positioning around TMK's). See description of reject codes preceding code E01.
- 4A4 TEST4A After finding 2 tape marks reading forward, read backward operation did not produce tape mark status.
 Card: DP
 Slot: A5
- 4A5 TEST4A Reject or Machine check from internal read backward. See description of reject codes preceding code E01.
- 4A6 TEST4A ID-burst status (6043) detected before reading 256 records. Tape must have been written by TEST48.
 Status A-0: record number (range: FF-00)
 Card: DP
 Slot: A5
- 4A7 TEST4A Data miscompare following read without data check (tape must have been written by TEST48). Comparison involved 32 bytes of write buffer (8000-801F) and 32 bytes of read buffer (8020-803F). Data should match record number below:
 Status A-0: record number expected (range: FF-00)
 Card: DP RD IF
 Slot: A5 A6 A3

Code	Detected by	Fault Description--FRU'S
------	-------------	--------------------------

- 4A8 TEST4A Unexpected tape mark (did not follow a 16 record group). Tape must have been written by TEST48.
 Status A-0: record number (range: FF-00)
 Card: DP
 Slot: A5
- 4AE TEST4A Failed internal record read with 5 retries.
 Status A-0,A-1: Low, high byte of record number
 (Range: 000-100 hex)
 ** Read/Write Error Tallies **
 Status A-8: Data checks Status A-C: Multi-trks
 Status A-9: Velocity Status A-D: Part. recd's
 Status A-A: End Data Chks Status A-E: Un-corr.
 Status A-B: Corrections Status A-F: CRC errors
 Status B-0 -> B-8: Dead track counters 0-7, P
 Status C-0 -> C-8: Phase error counters 0-7, P
 Card: DP IF
 Slot: A5 A3
- 4AF TEST4A Reject or Machine check from internal Forward-Space-Block command during read error recovery.
 See description of reject codes preceding code E01.
- 4B1 TEST4B Drive must be loaded
- 4B2 TEST4B Reject or Machine check from initial rewind.
 See description of reject codes preceding code E01.
- 4B3 TEST4B Reject or Machine check from read backward.
 See description of reject codes preceding code E01.

Code	Detected by	Fault Description--FRU'S
------	-------------	--------------------------

4B4 TEST4B Data checks occurred on 5 retries of read backward operation. Check tape quality.

** Read/Write Error Tallies **

Status A-8: Data checks Status A-C: Multi-trks
 Status A-9: Velocity Status A-D: Part. recd's
 Status A-A: End Data Chks Status A-E: Un-corr.
 Status A-B: Corrections Status A-F: CRC errors

Status B-0 -> B-8: Dead track counters 0-7, P
 Status C-0 -> C-8: Phase error counters 0-7, P

Card: DP RD
 Slot: A5 A6

4B5 TEST4B Reject or Machine check from forward-space-block command during read backward error recovery. See description of reject codes preceding code E01.

4B6 TEST4B Reject or Machine check from read forward. See description of reject codes preceding code E01.

4B7 TEST4B Data checks occurred on 5 retries of read forward operation. Check tape quality.

** Read/Write Error Tallies **

Status A-8: Data checks Status A-C: Multi-trks
 Status A-9: Velocity Status A-D: Part. recd's
 Status A-A: End Data Chks Status A-E: Un-corr.
 Status A-B: Corrections Status A-F: CRC errors

Status B-0 -> B-8: Dead track counters 0-7, P
 Status C-0 -> C-8: Phase error counters 0-7, P

Card: DP RD
 Slot: A5 A6

4B8 TEST4B Reject or Machine check from backward-space-block command during read forward error recovery. See description of reject codes preceding code E01.

Code	Detected by	Fault Description--FRU'S
------	----------------	--------------------------

4B9 TEST4B Reject or Machine check from forward-space-file.
See description of reject codes preceeding code E01.

4BA TEST4B Reject or Machine check from backward-space-file.
See description of reject codes preceeding code E01.

4BB TEST4B Reject or Machine check from forward-space-block.
See description of reject codes preceeding code E01.

4BC TEST4B Reject or Machine check from backward-space-block.
See description of reject codes preceeding code E01.

4BD TEST4B Tape Mark status set when not expected indicating
possible positioning problem.
(Tape must have been written by TEST48)

Card: DP
Slot: A5

4BE TEST4B Data miscompare indicating possible positioning
problem. (Tape must have been written by TEST48).

Card: DP
Slot: A5

4BF TEST4B Tape Mark status not set when not expected
indicating possible positioning problem.
(Tape must have been written by TEST48)

Card: DP
Slot: A5

4C1 TEST4C Drive must be loaded

4C2 TEST4C Tape must be write enabled

4C3 TEST4C Reject or Machine check from initial rewind.
See description of reject codes preceeding code E01.

Code	Detected by	Fault Description--FRU'S
------	-------------	--------------------------

4C4 TEST4C Reject or Machine check from internal write command.
 Status A-0,A-1: Low, high byte of record number.
 (Range: 000-100 hex)
 See description of reject codes preceding code E01.

4C5 TEST4C Write overrun status (6042) during internal
 write (data supplied to DP from IF card only).
 Status A-0,A-1: Low, high byte of record number.
 Range: 000-100 hex.

Card: IF DP
 Slot: A3 A5

4C6 TEST4C Bus parity error status (6042) during internal
 write (data supplied to DP from IF card only).
 Status A-0,A-1: Low, high byte of record number.
 (Range: 000-100 hex)

Card: IF DP
 Slot: A3 A5

4C8 TEST4C Reject or Machine check from back-space-block
 or erase-gap command during write error recovery.
 See description of reject codes preceding code E01.

4C9 TEST4C During write error recovery, all 5 retries failed.
 Status A-0,A-1: Low, high byte of record number.
 (Range: 000-100 hex)

Check tape quality.

Card: DP WR RD IF
 Slot: A5 A4 A6 A3

Code	Detected by	Fault Description--FRU'S
------	-------------	--------------------------

4CA TEST4C Reject or Machine check from write-tape-mark command.
 Status A-0,A-1: Low, high byte of record number (first WTM occurs at 10 hex)
 See description of reject codes preceding code E01.

4CB TEST4C During the writing of 256 GCR records, more than one temporary write error occurred.
 Status A-2: Total failing writes
 Status A-3: Temporary write errors (1 data check in 6 attempts)
 Status A-4: Media defects (>1 data check in 6 attempts)

** Read/Write Error Tallies **

Status A-8: Data checks Status A-C: Multi-trks
 Status A-9: Velocity Status A-D: Part. recd's
 Status A-A: End Data Chks Status A-E: Un-corr.
 Status A-B: Corrections Status A-F: CRC errors

Status B-0 -> B-8: Dead Track counters 0-7,P
 Status C-0 -> C-8: Phase error counters 0-7,P

Card: DP WR RD IF
 Slot: A5 A4 A6 A3

4D1 TEST4D Drive must be loaded

4D2 TEST4D Reject or Machine check from initial rewind.
 See description of reject codes preceding code E01.

4D3 TEST4D Reject or Machine check from internal read forward.
 Status A-0,A-1: Low, high byte of record number (Range: 000-100 hex)
 See description of reject codes preceding code E01.

Code	Detected by	Fault Description--FRU'S
------	-------------	--------------------------

- 406 TEST4D Unexpected tape mark (did not follow a 16 record group). Tape must have been written by TEST4C.
- Status A-0,A-1: Low, high byte of record number
(Range: 000-100 hex)
- Card: DP
Slot: A5
- 407 TEST4D Unexpected tape mark (more than 256 records read correctly, but tape mark did not follow 16 record group). Tape must have been written by TEST4C.
- Status A-0,A-1: Low, high byte of record number
(Range: 000-100 hex)
- Card: DP
Slot: A5
- 409 TEST4D Data miscompare following read without data check (tape must have been written by TEST4C). Comparison involved 32 bytes of write buffer (8000-801F) and 32 bytes of read buffer (8020-803F). Data should match record number below:
- Status A-0,A-1: Low, high byte of record number
(Range: 000-100 hex)
- Card: DP RD IF
Slot: A5 A6 A3
- 40B TEST4D Reject or Machine check from internal read forward over expected tape mark.
- Status A-0,A-1: Low, high byte of record number
(Range: 000-100 hex)
- See description of reject codes preceeding code E01.

Code	Detected by	Fault Description--FRU'S
------	-------------	--------------------------

4DC TEST4D Tape mark status not detected when expected (but 16 record group read OK).

Status A-0,A-1: Low, high byte of record number
(Range: 000-100 hex, first TMK @ 10)

Card: DP
Slot: A5

4DE TEST4D Failed internal record read with 5 retries.

Status A-0,A-1: Low, high byte of record number
(Range: 000-100 hex)

** Read/Write Error Tallies **

Status A-8: Data checks Status A-C: Multi-trks
Status A-9: Velocity Status A-D: Part. recd's
Status A-A: End Data Chks Status A-E: Un-corr.
Status A-B: Corrections Status A-F: CRC errors

Status B-0 -> B-8: Dead track counters 0-7, P
Status C-0 -> C-8: Phase error counters 0-7, P

Card: DP
Slot: A5

4DF TEST4D Reject or Machine check from internal Back-Space Block command during read error recovery.
See description of reject codes preceding code E01.

4E1 TEST4E Drive not loaded

4E2 TEST4E Reject or Machine check from internal read backward operation (searching for EOF tape marks).
See description of reject codes preceding code E01.

4E3 TEST4E Reject or Machine check from internal read forward operations (searching for EOF tape marks) or read backward operations (if positioning around TMK's).
See description of reject codes preceding code E01.

Code	Detected by	Fault Description--FRU'S
------	-------------	--------------------------

4E4 TEST4E After finding 2 tape marks reading forward, read backward operation did not produce tape mark status.

Card: DP
Slot: A5

4E5 TEST4E Reject or Machine check from internal read backward. See description of reject codes preceding code E01.

4E6 TEST4E ID-burst status (6043) detected before reading 256 records. Tape must have been written by TEST4C.

Status A-0: record number (range: FF-00)

Card: DP
Slot: A5

4E7 TEST4E Data miscompare following read without data check (tape must have been written by TEST4C). Comparison involved 32 bytes of write buffer (8000-801F) and 32 bytes of read buffer (8020-803F). Data should match record number below:

Status A-0: record number expected (range: FF-00)

Card: DP RD 1F
Slot: A5 A6 A3

4E8 TEST4E Unexpected tape mark (did not follow a 16 record group). Tape must have been written by TEST4C.

Status A-0: record number (range: FF-00)

Card: DP
Slot: A5

Code	Detected by	Fault Description--FRU'S
------	-------------	--------------------------

- 4EE TEST4E Failed internal record read with 5 retries.
 Status A-0,A-1: Low, high byte of record number
 (Range: 000-100 hex)
- ** Read/Write Error Tallies **
- Status A-8: Data checks Status A-C: Multi-trks
 Status A-9: Velocity Status A-D: Part. recd's
 Status A-A: End Data Chks Status A-E: Un-corr.
 Status A-B: Corrections Status A-F: CRC errors
- Status B-0 -> B-8: Dead track counters 0-7, P
 Status C-0 -> C-8: Phase error counters 0-7, P
- Card: DP IF
 Slot: A5 A3
- 4EF TEST4E Reject or Machine check from internal Forward-Space
 Block command during read error recovery.
 See description of reject codes preceeding code E01.
- 4F1 TEST4F Drive must be loaded
- 4F2 TEST4F Reject or Machine check from initial rewind.
 See description of reject codes preceeding code E01.
- 4F3 TEST4F Reject or Machine check from read backward.
 See description of reject codes preceeding code E01.

Code	Detected by	Fault Description--FRU'S
------	-------------	--------------------------

4F4 TEST4F Data checks occurred on 5 retries of read backward operation. Check tape quality.

** Read/Write Error Tallies **

Status A-8: Data checks Status A-C: Multi-trks
 Status A-9: Velocity Status A-D: Part. recd's
 Status A-A: End Data Chks Status A-E: Un-corr.
 Status A-B: Corrections Status A-F: CRC errors

Status B-0 -> B-8: Dead track counters 0-7, P
 Status C-0 -> C-8: Phase error counters 0-7, P

Card: DP RD
 Slot: A5 A6

4F5 TEST4F Reject or Machine check from forward-space-block command during read backward error recovery. See description of reject codes preceding code E01.

4F6 TEST4F Reject or Machine check from read forward. See description of reject codes preceding code E01.

4F7 TEST4F Data checks occurred on 5 retries of read forward operation. Check tape quality.

** Read/Write Error Tallies **

Status A-8: Data checks Status A-C: Multi-trks
 Status A-9: Velocity Status A-D: Part. recd's
 Status A-A: End Data Chks Status A-E: Un-corr.
 Status A-B: Corrections Status A-F: CRC errors

Status B-0 -> B-8: Dead track counters 0-7, P
 Status C-0 -> C-8: Phase error counters 0-7, P

Card: DP RD
 Slot: A5 A6

4F8 TEST4F Reject or Machine check from backward-space-block command during read forward error recovery. See description of reject codes preceding code E01.

Code	Detected by	Fault Description--FRU'S
------	-------------	--------------------------

4F9 TEST4F Reject or Machine check from forward-space-file.
See description of reject codes preceding code E01.

4FA TEST4F Reject or Machine check from backward-space-file.
See description of reject codes preceding code E01.

4FB TEST4F Reject or Machine check from forward-space-block.
See description of reject codes preceding code E01.

4FC TEST4F Reject or Machine check from backward-space-block.
See description of reject codes preceding code E01.

4FD TEST4F Tape Mark status set when not expected indicating possible positioning problem.
(Tape must have been written by TEST4C)

Card: DP
Slot: A5

4FE TEST4F Data miscompare indicating possible positioning problem. (Tape must have been written by TEST4C).

Card: DP
Slot: A5

4FF TEST4F Tape Mark status not set when not expected indicating possible positioning problem.
(Tape must have been written by TEST4C)

Card: DP
Slot: A5

C01 FEIDLE Test requested for execution does not exist in internal routine library.

Code	Detected by	Fault Description--FRU'S
------	-------------	--------------------------

The following codes are not displayed on the panel as such, but referred to by other code descriptions in this dictionary. The Exx codes indicate rejects, where xx is the hex equivalent of reject codes normally returned to the host system. In this case they were actually returned to the internal diagnostics which has left them in a fixed status location:

Status A-5 = xx, see code Exx

- E01 The subsystem is not in ready status.
- E03 During a write operation, TRAK was not returned within 75 milliseconds of TREQ.

 Card: IF DP
 Slot: A3 A5
- E05 File protect status was detected on a write request.
- E06 Erase status was not detected.

 Card: WR IF
 Slot: A4 A3
- E08 Read status was not detected.

 Card: WR IF
 Slot: A4 A3
- E09 If read operation:
 No density status (DP card) within 5 inches.
 If write operation:
 DP interrupt during writing of ID track, or
 DP reject status during writing of ID track.

 Check tape quality.

 Card: DP WR
 Slot: A5 A4

Code	Detected by	Fault Description--FRU'S
------	-------------	--------------------------

- E0C Write status was not detected.

 Card: WR IF
 Slot: A4 A3
- E0F Noise detected during an erase gap or during a
 read/write command sequence.

 Check tape quality.

 Card: DP RD IF
 Slot: A5 A6 A3
- E11 Machine Check condition detected.

 Status A-6 = Code of machine check: xx
 See description of code Fxx.
- E13 Backward operation requested at BOT.
- E14 During the writing of ARA burst portion of tape
 ID, data path (DP) returned reject status.

 Check tape quality.

 Card: DP RD IF
 Slot: A5 A6 A3
- E15 Blank tape: PE--25 foot limit; GCR--15 foot limit.
- E18 Following write of ID track at BOT, proper density
 status was not returned from data path (DP).

 Card: WR DP SV IF
 Slot: A4 A5 A1 A3
- E19 LWR attempted with tape loaded and away from bot.
- E1A Subsystem failed to initiate tape motion.

Code	Detected by	Fault Description--FRU'S
------	----------------	--------------------------

E1B During a read back check of a write operation, data was detected in the ibg area either before or after the record written.

Check tape quality.

Card: RD Read/Write head (feedthru)
Slot: A6

E1D Record not found during a backspace operation over an incorrectly written record.

Check tape quality.

Card: DP RD IF
Slot: A5 A6 A3

E1E During a write from BOT, data path (DP) rejected ARA ID after successfully writing ID track and ARA burst.

Check tape quality.

Card: DP RD IF
Slot: A5 A6 A3

E1F No data detected during the read back check of a write or write tape mark command.

Check tape quality.

Card: DP RD IF
Slot: A5 A6 A3

Code	Detected by	Fault Description--FRU'S
------	-------------	--------------------------

F01 'TAPE PRESENT' not seen during thread operation.

If blower inactive during load procedure, check:

- 1) Power supply high voltage (AK card).
- 2) J18/P18 connector
- 3) Solid state relay (motherboard).
- 4) Blower Motor

If not detecting tape in path (FILE reel never accelerated):

Card: WR EOT/BOT IF
Slot: A4 Sensor A3

F02 Failed to load tape in three retries.
Check that leader is free.

If blower inactive during load procedure, check:

- 1) Power supply high voltage (AK card).
- 2) J18/P18 connector
- 3) Solid state relay (motherboard).
- 4) Blower Motor

If no FILE reel rotation:

Card: SV AK
Slot: A1 Pwr Supply

If leader not detected (forward FILE reel motion):

Card: WR Leader IF
Slot: A4 Sensor A3

F03 Failed to sense leader during load.
Check that leader is free.

If leader not detected (forward FILE reel motion):

Card: WR Leader IF
Slot: A4 Sensor A3

F04 Leader status always asserted during load attempt.

Card: WR Leader IF
Slot: A4 Sensor A3

Code	Detected by	Fault Description--FRU'S
------	-------------	--------------------------

F05	<p>BOT not found during forward search. Check for reflective sticker on tape. Check EOT/BOT SENSOR connections.</p> <p>Card: WR IF Slot: A4 A3</p>
F06	<p>BOT failed to drop in expected time. Check EOT/BOT SENSOR connections.</p> <p>Card: WR IF Slot: A4 A3</p>
F08	<p>File protect status check was inconclusive. Check FILE PROTECT SENSOR connections.</p> <p>Card: WR IF Slot: A4 A3</p>
F09	<p>SENSOR ERROR (6060) status indicated. Check all sensor connections.</p> <p>Card: WR IF Slot: A4 A3</p>
F10	<p>Swing arms not both retracted on load initiation. Check swing arm retraction tolerances.</p>
F11	<p>Swing arms still retracted after extend command.</p> <p>Check swing arm motor and mechanism for jams. Check motor drive cable connections.</p> <p>Card: SV WR IF Slot: A1 A4 A3</p>
F12	<p>'INDEX' not detected during servoing of swing arms.</p> <p>Card: WR IF SV Slot: A4 A3 A1</p>

Code	Detected by	Fault Description--FRU'S
------	-------------	--------------------------

F13 LOAD Swing arms failed to reach 'EXTENDED' status in 2 seconds.

If arms not in 'EXTENDED' position and no motion:
 Check retractor motor and mechanism for jams.
 Check retractor motor fuse (inline).
 Check power supply (+/- 24/36 volts).
 Card: SV IF
 Slot: A1 A3

If arms at 'EXTENDED' position:
 Check 'EXTENDED' switch and connections.
 Card: WR IF
 Slot: A4 A3

F14 LOAD From 'EXTENDED', failed to sense both swing arms in 'INDEX' area in 900 ms.

Check 'EXTENDED' switch function (probe 6061).
 If display (04 bit) does not change when EXTENDED switch is manually toggled:

Card: Extended WR IF
 Slot: Switch A4 A3

Check 'INDEX' from both sensors (probe 6061) by manually moving arms from 'EXTENDED' position.
 01 bit represents MACH arm (upper) 'INDEX'.
 02 bit represents FILE arm (lower) 'INDEX'.

If neither bit toggles:
 Card: WR IF
 Slot: A4 A3

If only 01 bit toggles:
 Card: WR FILE ARM/TACH
 Slot: A4 SENSOR

If only 02 bit toggles:
 Card: WR MACH ARM/TACH
 Slot: A4 SENSOR

If NO swing arm motion in retract direction:
 Check power supply (+/- 24/36 volts).
 Card: SV IF
 Slot: A1 A3

Code	Detected by	Fault Description--FRU'S
------	-------------	--------------------------

F16 LOAD After sensing 'EXTENDED' (switch) and 'INDEX' active (rotary sensors) for both arms, failed to detect arms retracted (INDEX's reset then set again).

Check 'EXTENDED' switch function (probe 6061).
If display (04 bit) does not change when EXTENDED switch is manually toggled:

Card: Extended WR IF
Slot: Switch A4 A3

Otherwise (display does change):

Card: SV WR IF File/Mach
Slot: A1 A4 A3 Tach Asmbly

F19 LOAD After initiating a manually controlled load (horizontally configured machine or double depression of "LOAD" push-button), 30 seconds expired without an operator indication to continue (moving tape leader into thread channel or an additional "LOAD" depression).

If blower inactive during load procedure, check:

- 1) Power supply high voltage (AK card).
- 2) J18/P18 connector
- 3) Solid state relay (motherboard).
- 4) Blower Motor

If not detecting tape in path:

Card: WR EOT/BOT IF
Slot: A4 Sensor A3

F20 Data path issued reject for unknown reasons.

Card: DP IF
Slot: A5 A3

F30 Following the servoing of the swing arms, an unstable capstan was detected. Check for proper tape threading.

Card: SV IF AK
Slot: A1 A3 (Power Sply)

Code	Detected by	Fault Description--FRU'S
------	-------------	--------------------------

F40 Drive unable to return to BOT; EPO forced.
Operator RESET or turn-around failure.

Card: SV IF
Slot: A1 A3

F50 Door interlock switch is indicating open door.

Card: SV IF
Slot: A1 A3

F70 Data path interrupt failed to occur in expected time.

Card: DP IF
Slot: A5 A3

F71 Position count interrupt failed to occur in expected time.

Card: SV IF
Slot: A1 A3

F80 Drive did not reach velocity in 10 ms.

Card: SV IF
Slot: A1 A3

F81 Turn around conditions not met within 1 second.

Card: SV IF
Slot: A1 A3

F82 Failed to reach 'stop' condition in 10 ms.

Card: SV IF
Slot: A1 A3

Code	Detected by	Fault Description--FRU'S
------	-------------	--------------------------

F85 Acceleration or deceleration ramp out of spec.
 Card: SV IF
 Slot: A1 A3

F90 Write or erase current on after read mode request.
 Card: WR IF
 Slot: A4 A3

F91 Write or erase current failed during write.
 Card: WR IF
 Slot: A4 A3

F92 Write current on while in erase-only mode.
 Card: WR IF
 Slot: A4 A3

F93 Erase current failure while in erase-only mode
 Card: WR IF
 Slot: A4 A3

F96 Nonmaskable interrupt (NMI): Unknown or multiple.
 Card: SV IF
 Slot: A1 A3

F97 Nonmaskable interrupt (NMI): Power failure.
 Card: SV IF
 Slot: A1 A3

F98 Nonmaskable interrupt (NMI): Swing arms looped out.
 Card: SV IF
 Slot: A1 A3

Code	Detected by	Fault Description--FRU'S
------	----------------	--------------------------

F99 Nonmaskable interrupt (NMI): Watch-dog timer expired

Card: SV IF
Slot: A1 A3

APPENDIX B

SPECIAL TEST EQUIPMENT, TOOLS, AND SUPPLIES

This appendix lists the special test equipment, special tools, and supplies required to maintain the MTS. The part numbers provided are Storage Technology part numbers unless otherwise specified.

ITEM	PART NUMBER	FUNCTION
Cleaning Kit includes: Hub/Transport Cleaner Fluid Lint-free Cloth Foam-Tipped Swabs	6164 402626502 6168 11698	Tape path cleaning
Wrist Strap	24000027	Circuit card handling
Master Alignment Tape	4611-01 4611-02	Read/write head alignment
Master Output Tape	401202102	Read amplitude check
Tape Developer (Magna-See)	4583	Bit position check
Jeweler's Loupe (optional)	Bauch&Lomb 81-34-35	Bit position check
Torque Screwdriver Torx T15 for #6 screws Torx T25 for #10 screws Torx T30 for 1/4" screws Torx key for #6 screws	403443401 403443501 403443601 403443701	Screw removal

(INTENTIONALLY LEFT BLANK)

APPENDIX C
DATA FORMATS

C.1 INTRODUCTION

The MTS is capable of formatting and deformatting data in both PE and GCR recording modes. This appendix describes how each recording mode is formatted.

C.2 PHASE ENCODED (PE) OPERATION (1600 BPI)

ANSI Compatibility. The MTS writes and reads half-inch magnetic tapes in phase-encoded recording mode as specified by ANSI x3.39-1973.

Recorded Format. The PE recorded format is as shown in Figure C-1. Recording density is 1600 bits per inch (nominal).

Block Length. The MTS does not control or limit the number of data characters within a block or record except to disallow the writing of data blocks containing no data characters. The USER has control over block size and may exceed the ANSI-specified maximum and minimum values. Minimum block size is one byte.

Maximum Interblock Gap (IBG). The USER may generate extended length IBGs by issuing multiple Erase Gap (ERG) commands. The USER should avoid generating gaps in excess of the ANSI-specified maximum of 25 feet. When reading, detection of an erase section in excess of 25 feet causes Empty Tape Error to be set.

End of Recording Area. The USER must control or limit operations beyond the EOT marker (end of recording area).

Tape Mark Block. A tape mark will be read if sufficient characters in zone 2 with at least one track of zone 1 together with the erasure of zone 3 can be detected or zone 1 and erasure of zone 3.

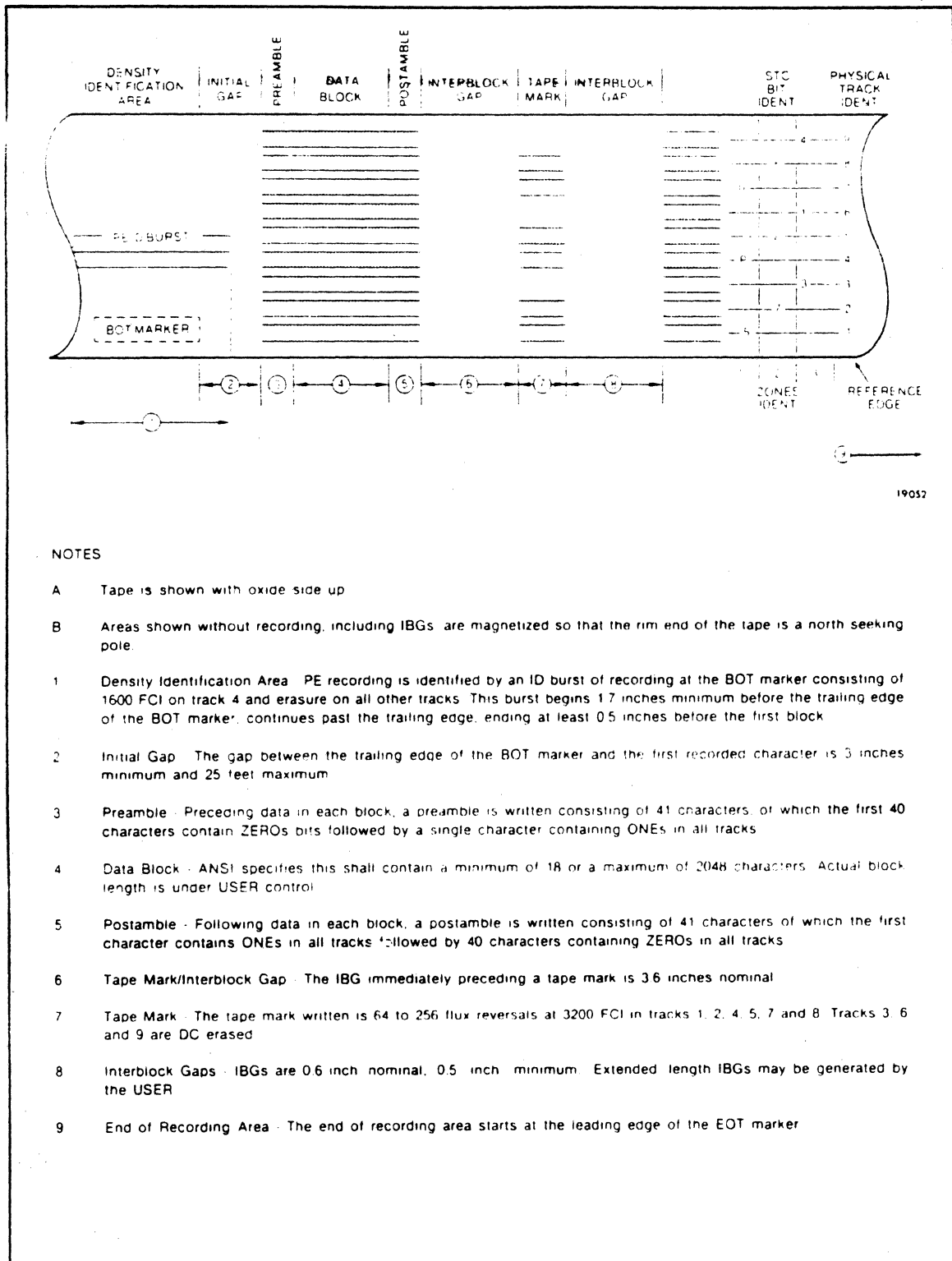

19052

NOTES

- A Tape is shown with oxide side up
- B Areas shown without recording, including IBGs are magnetized so that the rim end of the tape is a north seeking pole.
- 1 Density Identification Area PE recording is identified by an ID burst of recording at the BOT marker consisting of 1600 FCI on track 4 and erasure on all other tracks. This burst begins 1.7 inches minimum before the trailing edge of the BOT marker, continues past the trailing edge, ending at least 0.5 inches before the first block.
- 2 Initial Gap The gap between the trailing edge of the BOT marker and the first recorded character is 3 inches minimum and 25 feet maximum.
- 3 Preamble Preceding data in each block, a preamble is written consisting of 41 characters, of which the first 40 characters contain ZEROS bits followed by a single character containing ONES in all tracks.
- 4 Data Block ANSI specifies this shall contain a minimum of 18 or a maximum of 2048 characters. Actual block length is under USER control.
- 5 Postamble Following data in each block, a postamble is written consisting of 41 characters of which the first character contains ONES in all tracks followed by 40 characters containing ZEROS in all tracks.
- 6 Tape Mark/Interblock Gap The IBG immediately preceding a tape mark is 3.6 inches nominal.
- 7 Tape Mark The tape mark written is 64 to 256 flux reversals at 3200 FCI in tracks 1, 2, 4, 5, 7 and 8. Tracks 3, 6 and 9 are DC erased.
- 8 Interblock Gaps IBGs are 0.6 inch nominal, 0.5 inch minimum. Extended length IBGs may be generated by the USER.
- 9 End of Recording Area The end of recording area starts at the leading edge of the EOT marker.

Figure C-1. PE Tape Format

C.3 GROUP-CODED RECORDING (GCR) OPERATION (6250 BPI)

ANSI Compatibility. The MTS writes and reads half-inch magnetic tapes in group-coded recording mode as specified by ANSI x3.54-1976.

Recorded Format. The GCR recorded format is as shown in Figures C-2 and C-3. Recording density is 6250 bits per inch (nominal).

Block Length. The MTS does not control or limit the number of data characters within a block or record except to disallow the writing of data blocks containing no data characters. The USER has control over block size and may exceed the ANSI-specified maximum and minimum values. Minimum block size is one byte.

Maximum Interblock Gap (IBG). The USER may generate extended length IBGs by issuing multiple Erase Gap (ERG) commands. The USER should avoid generating gaps in excess of the ANSI-specified maximum of 15 feet. When reading, detection of an erase section in excess of 15 feet causes Empty Tape Error to be set.

End of Recording Area. The USER must control or limit operations beyond the EOT marker (end of recording area).

Tape Mark Block. A tape mark will be read if sufficient characters in zone 2 with at least one track of zone 1 together with the erasure of zone 3 can be detected or zone 1 and erasure of zone 3.

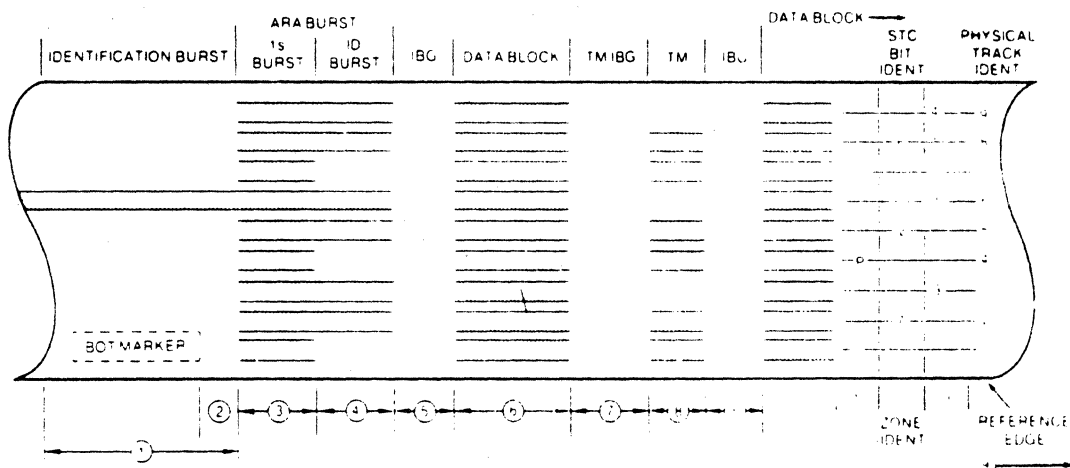

19014

NOTES:

- A Tape is shown oxide side up
- B Areas shown without recording, including IBGs, are magnetized so that the rim end at the tape is a north seeking pole
- 1 Identification Burst - The GCR recording method is identified by a burst of recording at the BOT marker. The burst is in the PE frequency range (1600 BPI) on track 6 and erasure on all other tracks. The ID burst begins 1.7 inches minimum before the leading edge of BOT and continues past the trailing edge of the BOT marker.
- 2 ARA Burst - The ARA burst enables the capability of writing all tracks to be verified. It begins no sooner than 1.5 inches and no later than 4.3 inches as measured from the leading edge of the BOT marker.
- 3 ARA 1s Burst - Immediately following the ID Burst there is an ARA Burst (all ONEs in all tracks) which is separated from the ID Burst by an undefined gap. It ends no sooner than 9.5 inches and no later than 11.5 inches as measured from the leading edge of the BOT marker.
- 4 ARA ID Burst - Appended to the end of the ARA 1s Burst is an ID character consisting of ONEs in tracks 2, 3, 5, 6, 8, and 9 and erasure in tracks 1, 4, and 7. This ID character is approximately 2 inches long. (At least) a contiguous 1/4-inch section of this 2-inch long burst must be error free in all tracks simultaneously. There is a normal IBG between the ARA ID character and the first data block.
- 5 Interblock Gaps - IBGs are 0.285 inch minimum and 0.3 inch nominal. Extended length IBGs may be generated by the USER.
- 6 Data Block - See GCR Data Block Format illustration.
- 7 Tape Mark Interblock Gap - The IBG immediately preceding a tape mark is 3.3 inches nominal.
- 8 Tape Mark - The tape mark written consists of 400 flux changes (all ONEs) at 9042 FCI in physical tracks 2, 5, 8, 1, 4 and 7 and no recording in physical tracks 3, 6, and 9.
- 9 End of Recording Area - The end of recording area starts at the leading edge of the EOT marker.

Figure C-2. GCR Tape Format

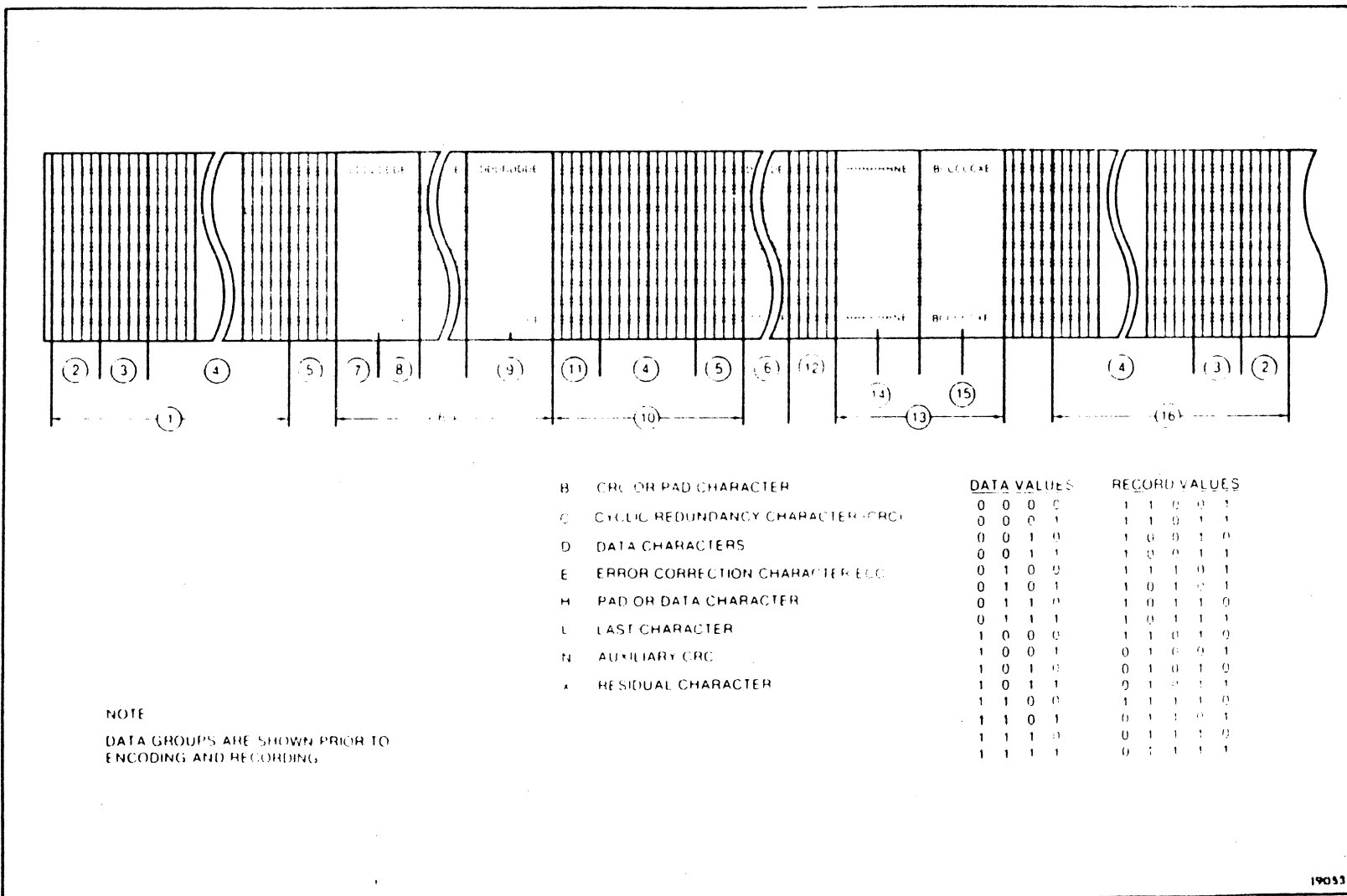

Figure C-2. GCR Data Block Format (Sheet 1 of 3).

The following are notes that explain sheet 1 of the Figure. These notes are numbered to correspond with the numbers on the illustration.

NOTES

- ① Preamble - Sixteen subgroups of five bytes each. The subgroups initiate the read circuits and synchronize them.
- ② Terminator Control Subgroup - The data pattern in this subgroup provides for a long wave length input to the read detection circuits, thus ensuring high level inputs into the circuits at the beginning of a read operation. These inputs in turn ensure that the Read Detectors are turned ON before they are synchronized.

The Terminator Control Subgroup is one set of nine parallel 5-bit serial values of 10101 in all tracks located at the BOT end of each block and 1010L at the EOT end of each block, where L represents the resetting of the last character (which restores the Write Triggers to the erase state).
- ③ Second Control Subgroup - This is a part of sync, explained below. The Second Control Subgroup consists of 5 bit serial values of 01111 in all tracks for the BOT end of the block and 11110 for the EOT end of the block.
- ④ Sync Control Subgroups - These are fourteen five-byte subgroups which synchronize the Read Reference Oscillator. Each subgroup consists of 5-bit serial values of all 15³ in all tracks.
- ⑤ Mark 1 Control Subgroup - This subgroup marks the coming of data. It ensures that the buffer counters are properly initiated so the data being read is formatted into the correct five-byte groups. This is necessary for correct decoding (retranslation from five to four bit codes) of the data which is being read. The Mark 1 Control Subgroup is one set of 5 bit serial values of 00111 on all tracks. On backward operations, the Mark 1 becomes the Mark 2 Subgroup.
- ⑥ Data - Any recorded section of the tape which has only data and the ECC recorded on it (no Control Subgroups). The data is formatted into groups and the groups are divided into subgroups. These data subgroups are identified as data subgroup A and data subgroup B.

Data Values/Record Values - During GCR recording, four bits from each track are translated into the five bit code. After translation, the five-bit code is moved serially to the TU for recording. The data values and record values show the bit patterns before and after translation. During read operations, the five bit code is reconverted to the original four bits. Thus the data sent to the CPU is in its original form.
- ⑦ Data Subgroup A consists of four data bytes before translation (the storage group).
- ⑧ Data Subgroup B consists of three data bytes and one ECC (Error Correction Character) before translation. The ECC is used for data correction. All data correction in GCR is done on the eight byte data groups (Byte 8 is the ECC).
- ⑨ There may be no more than 158 contiguous data groups in a recorded data block. If there are more than 1112 data bytes (before translation) in an incoming record, resynchronization is necessary before the recording can be continued.
- ⑩ Resync Burst - This burst is used to resynchronize the data of failing tracks when a data record is longer than 1112 data bytes (before translation). See Notes 6 through 9.
- ⑪ Mark 2 Control Subgroup - This subgroup marks the ending of data and the coming of non-data information. The Mark 2 Control Subgroup consists of one set of 5 bit serial values of 11100 on all tracks. On backward operations, the Mark 2 becomes the Mark 1 Subgroup.
- ⑫ End Mark Control Subgroup - This control subgroup warns of the approach of the Residual Data Group, which is defined in Note 14. The End Mark Control Subgroup consists of one set of 5 bit serial values of 11111 on all tracks.
- ⑬ RES-CRC Data - This data includes both the Residual Data Group and the CRC Data Group (these groups are described in Notes 14 and 15). These two groups are written at the end of a data record.

Figure C-3. GCR Data Block Format (Sheet 2 of 3)

⑭ **Residual Data Group** - This group is formed when there are six or less data bytes remaining in a data record. If six data bytes remain, the seventh byte of the Residual Data Group is the Auxiliary CRC Character (a data validity check character) and byte eight is the normal ECC. If there are less than six residual data bytes, pad characters of all zeros with correct parity are added to the data group to pad it to six bytes. Thus, the Residual Data Group consists of the remaining data bytes, the pad characters, the Auxiliary CRC Character (N), and the ECC (E). (All data groups must have eight bytes total in GCR mode.)

⑮ Before this data group is written, the CRC character normally has odd parity if there was an odd number of data groups and even parity if there was an even number of data groups. If the record had an odd number of data groups the CRC character is even. Since an even parity byte is not allowed in a GCR Data Group, the CRC character must be made odd. To accomplish this, an additional pad byte consisting of all zeros and a parity bit (B) is added to the record. The addition of this byte changes the number of bytes in the CRC generation and provides an odd parity CRC character.

The next five bytes of the CRC Data Group are identical CRC characters. The additional CRC characters serve to fill the CRC Data Group since there is no more data to be read.

Next in the CRC Data Group is the Residual character (X). By definition, this character is used as a record data counter. Bits 3-7 are the modulo 32 counter. These bits are used by STC in a proprietary manner. Bits 0-2 are used as a modulo 7 counter to indicate how many of the Residual Data Group bytes are data. The modulo 7 count of the Residual character indicates how many data bytes are to be retrieved from the Residual Data Group.

The ECC in this data group, as in all other data groups, is used to verify the correctness of data in the group and to isolate the error, if any, during read operations for data correction.

⑯ **Postamble** - The Postamble is the mirror image of the Preamble except for the terminator control subgroup. In read backward operations, the Postamble is used the same way the Preamble is used in read forward operations. See the description of Preamble in Notes 1 through 4.

Check Characters - Three Check Characters are used in the GCR tape format: CRC (B), Auxiliary CRC (N), and ECC (E).

The CRC characters are used to verify data validity during write and read back check operations. The ECC is used to verify data validity and for data error identification and correction during read operations.



APPENDIX D
MEMORY ALLOCATION

MEMORY MAP

0000			
1000	Functional PROM 1	(0000-1FFF)	8k
2000			
3000	Functional PROM 2	(2000-3FFF)	8k
4000			
5000	Diagnostic PROM	(4000-5FFF)	8k
6000			
7000	Memory-Mapped I/O	(6000-7FFF)	8k
8000			
9000	Diagnostic RAM*	(8000-87FF)	2k
A000	/ / / / / / / / / / / / /		
B000	Functional RAM	(A000-A7FF)	2k
C000	/ / / / / / / / / / / / /		
D000	/ / / / / / / / / / / / /		
E000	/ / / / / / / / / / / / /		
F000	/ / / / / / / / / / / / /		
	* The first 64 bytes of Diagnostic RAM (8000-803F) constitute the internal LWR buffer.		

KEYBOARD/OP PANEL REGISTER ALLOCATION

Read Keyboard (0 = key depressed)

KBDATA

6010
R/O

			Co14	Co13	Co12	Co11	Co10
--	--	--	------	------	------	------	------

DIAGNOSTIC REGISTER ALLOCATION

Diagnostic Status (IDG)

DIAGSTAT

6014
R/O

					Diag Read Done	Diag Write Done	Diag Prty Error
--	--	--	--	--	----------------	-----------------	-----------------

RDFIN WTFIN PRITY

Read Diagnostic Download Byte

DIAGDWNL

6017
R/O

msb	lsb
-----	-----	-----	-----	-----	-----	-----	-----

Servo Diagnostic Status

DIAGSERV

6050
R/O

Tach Phase A	Tach Phase B			Mach Pump Down	Mach Pump Up	File Pump Down	File Pump Up
--------------	--------------	--	--	----------------	--------------	----------------	--------------

TACHA TACHB

MPD MPU FPD FPU

Diagnostic Sense (ISN)

DIAGSENS

6078
R/O

Diag Switch 1	Diag Switch 0	Buper	Stop	Trak	Diag Sel 2	Diag Sel 1	Diag Sel 0
---------------	---------------	-------	------	------	------------	------------	------------

JSTPE

STOP TRAK

CAPSTAN CONTROL REGISTER ALLOCATION

Read Position Count							PCREAD
6025 R/O	msb	1sb

Read Capstan Velocity							VR
6027 R/O	msb	1sb

REEL CONTROL REGISTER ALLOCATION

Read Machine Position Count							READMPOS
6034 R/O	msb	1sb

Read File Position Count							READFPOS
6035 R/O	msb	1sb

Reel Status (RSS)							SRVOSENS
6036 R/O	Mach Phase B	Mach Phase A	File Phase B	File Phase A	Watch Dog EPO	Loop Out EPO	Power Fail EPO
	MPHSB	MPHSA	FPHSB	FPHSA	WDERR	LOOPF	PWRF

Read Thread Counter							THRDREAD
603B R/O	msb	1sb

DATA PATH CARD REGISTER ALLOCATION

Dead Track Register (-)

DTREG

6040
R/O

(-) Dead Trk 7	(-) Dead Trk 0
----------------------	-----	-----	-----	-----	-----	-----	----------------------

Data Path Status A (DSA)

DPSTATA

6041
R/O

Write TM Check	Uncor Error	Part Rec	Mult Track Error	Read Corr	End Data Check	Vlcty Check	
----------------------	----------------	-------------	------------------------	--------------	----------------------	----------------	--

WTMCK UNCOR PRTRC MTE RDCOR ENDCK VELCK

Data Path Status B (DSB)

DPSTATB

6042
R/O

Cmd Rej	ID Check	Read Ovrfl	Write Ovrfl	CRC C	CRC A	CRC	Buper
------------	-------------	---------------	----------------	----------	----------	-----	-------

REJ IDCHK ROVR WOVR CRCC CRCA CRC BUPER

Data Path Status C (DSC)

DPSTATC

6043
R/O

Over Block	Data Avail	PE ID	GCR ID	TM Stat	-DT P	AS P	Ph P
---------------	---------------	----------	-----------	------------	-------	------	------

BLOCK DAVAIL PEID GCRID TMS NDTP ASP PHASP

Phase Pointers

PHASREG

6044
R/O

Phase Pntr Trk 7	Phase Pntr Trk 0
------------------------	-----	-----	-----	-----	-----	-----	------------------------

Amp Sensors

AMPSREG

6045
R/O

Amp Sense Trk 7	Amp Sense Trk 0
-----------------------	-----	-----	-----	-----	-----	-----	-----------------------

WRITE DRIVER AND SENSOR REGISTER ALLOCATION

Sensors (SS1)

SENSORS

6060 R/O	EOT	BOT	Tape Prsnt	Leadr Seen	File Prot			Sensr Error
	EOT	BOT	TAPE	LEADR	FILEP			ERROR

Current Monitor (WMN)

CURRNTM

6061 R/O	All Trks Wrt	Erase Curr On	All Trks Off	(-) Wrt F Itrpt		Arms Extnd	File Arm Index	Mach Arm Index
	WRTAL	ERS	WROFF	CUROK		XTEND	FINDX	MINDX

INTERFACE REGISTER ALLOCATION

Interface Command (ICM)

INTFCMD

6077 R/O	Sys Reset Latch	Addr Match	Dens Sel 1	Dens Sel 0	Cmd Bit 3	Cmd Bit 2	Cmd Bit 1	Cmd Bit 0
	SYSRS	SELCT	NRZI	GCR				

(INTENTIONALLY LEFT BLANK)

INDEX

Address Selection	3-10	End of Data Pulse (ENDATP)	4-9
AK Card Replacement	7-22	End of Tape Status (EOTS)	4-18, 4-20
Backspace a Block (BSB)	4-28	Ending Status Validity	4-20
Backspace File (BSF)	4-28	Enter Address Key	2-6
Backward Motion	8-3	Enter Diagnostic Key	2-8
Beginning of Tape Status (BOTS)	4-18	Enter Key	2-8
Bi-Directional Data (DATA)	4-8	Enter Probe Key	2-7
Bit Position Check	6-8	Environmental Requirements	1-5
Block Sensed (BLOCK)	4-9	EOT/BOT Indicator	2-2
BSB/BOT	4-29	EOT/BOT Sensor Cleaning	2-11
BSB/Tape Mark	4-29	Replacement	7-3
BSF/BOT	4-28	EPROM Error (ROMPS)	4-11
Busy (BUSY)	4-9	Erase Gap (ERG)	4-31
Bypass Error Option	8-5	ERG/BOT	4-31
Cabinet Mounting	3-6	Error Multiplex (ERRMX x)	4-12
Capstan Cleaning	2-13	Expecting Data (RECV)	4-9
Alignment	6-3	External Diagnostics	8-18
Cleaning	2-11	Fault Code Dictionary	A-1
Capstan Motor Replacement	7-17	File Protect Indicator	2-4
Circuit Cards Replacement	7-21	File Protect Sensor Replacement	7-5
Clear Key	2-8	File Protect Status (FPTS)	4-18
Command Initiation	4-19	File Reel Hub Cleaning	2-13
Command Reject (REJECT)	4-10	Cleaning	2-13
Command Select (CMDx)	4-5	Replacement	7-18
Commands with MTS in Write Status	4-21	File Reel Motor Replacement	7-19
Continue Option	8-4	Formatter Tests	8-10
Cooling Fan Replacement	7-25	Forward Motion	8-3
Corrected Error (CRERR)	4-15	Forward Space a Block (FSB)	4-30
Counters	8-9	Forward Space File (FSF)	4-29
Data Bus Parity Error (BUPER)	4-15	Front Operator Panel Replacement	7-22
Data Check (DATA CHK)	4-11	FSB/BOT	4-30
Data Formats	C-3	FSB/Tape Mark	4-30
Data Path Status	8-10	FSF/BOT	4-30
Density Select (DSx)	4-5	Fuses	7-1
Density Select Key	2-4	GCR Amplitude Sensor	8-15
Diagnostic Keypad	2-5	GCR Basic Loop Write-to-Read	8-11
Diagnostic Mode Set (DMS)	4-22	GCR LWR Velocity	8-12
Display	2-1	GCR LWR, One Track Dead	8-13
Display Address Key	2-6	GCR Operation	5-11
Drive Basic Motion	8-14		
Drive Clear (CLR) Command	4-21		
Drive Rewind	8-15		

INDEX (CONT)

GCR Positioning	8-17	MTS Address (ADx)	4-1
GCR Read Backward	8-17	Mux Byte 0	4-12
GCR Read Forward	8-17	Mux Byte 1	4-13
GCR Write Records	8-17	Mux Byte 2	4-14
General Description	1-1	Mux Byte 3	4-15
Group-Coded Recording (GCR) Operation	C-3	No Operation (NOP)	4-21
High Density Status (HDNS)	4-18	On Line Indicator	2-2
Horizontal Mount	3-10	On Line Key	2-5
Identification Burst (ID BRST)	4-10	Online Status (ONLS)	4-17
Improper Command Sequences	4-21	Operating Procedures	2-9
Initiate Command (START)	4-3	Operation Completed	4-19
Inspection	3-1	Operation Incomplete (OP INC)	4-11
Interface Cabling	3-10	Operator Functions Area	2-2
Interface/Microprocessor (IF Card)	5-1	Operator Maintenance	2-11
Internal Diagnostics	8-7	Oscillator (OSC)	4-9
Interrupt Controller	8-9	Output Signal Definitions	4-8
Keyboard Status	8-9	Overrun Status (OVRNS)	4-11
Keyboard/LED Driver	8-5	PE Amplitude Sensor	8-15
Leader Sensor Cleaning	2-11	PE Basic Loop Write-to-Read	8-11
Replacement	7-4	PE LWR Velocity	8-11
Load/Rewind Key	2-5	PE LWR, One Track Dead	8-12
Loop Option	8-4	PE LWR, Two Tracks Dead	8-13
Loop Write-to-Read (LWR)	4-27	PE Operation	5-9
Lower Swing Arm Assembly Replacement	7-7	PE Positioning	8-16
Lower Swing Arm Tach Assembly Replacement	7-10	PE Read Backward	8-16
Machine Check Indicator	2-2	PE Read Forward	8-16
Machine Reel Motor Replacement	7-20	PE Write Records	8-16
Main Circuit Breaker Replacement	7-25	Phase Encoded (PE) Operation	C-1
Maintenance Routines	8-2	Physical Dimensions	1-5
Maintenance Write	8-6, 8-6	PK Card Replacement	7-23
Memory Allocation	D-9	Power Connection	3-4
Memory/PROM Checksum	8-9	Power On/Off Switch	2-1
Modify Memory Key	2-7	Power Requirements	1-6
Motherboard Replacement	7-23	Power Supply Check	6-2
		Power System	5-15
		Power-Up Tests	8-7
		Preliminary Checkout	3-4
		Preventive Maintenance	6-1

INDEX (CONT)

RDB/BOT	4-24	Supplies, Special	B-1
RDB/Tape Mark Blocks	4-25	Swing Arms Cleaning	2-11
RDF/BOT	4-24	Swing Arms	7-7
RDF/Tape Mark Blocks	4-24	System Reset (RESET)	4-7
Read (RD Card)	5-7	System Select/1600/6250	
Read Amplitude Checks	6-9	Indicators	2-4
Read Backward a Block			
(RDB)	4-24	Tape Cleaner Block	
Read Data Path (DP Card)	5-9	Cleaning	2-11
Read Forward a Block		Replacement	7-4
(RDF)	4-22	Tape Guides Cleaning	2-11
Read/Write Head		Tape Mark Status (TMS)	4-10
Cleaning	2-11	Tape Path	7-3
Replacement	7-5	Tape Tracking and Skew	6-2
Read/Write Tests	8-15	Terminate Command (STOP)	4-7
Ready Indicator	2-2	Test Equipment, Special	2-11
Ready Status (RDYS)	4-18	Test Initiation	8-1
Rectifier Assembly		Test Package Initiator	8-7
Replacement	7-24	Thread/Load	2-9
Reel/Capstan Driver	8-5	Tools, Special	2-11
Reject Conditions	4-19	Torx Screws	7-3
Release/Retract Swing Arms	8-10	Transfer Acknowledge	
Reset Key	2-5	(TRAK)	4-6
Reshipping	3-10	Transfer Request (TREQ)	4-8
Retractor Motor		Transformer Replacement	7-24
Replacement	7-14	Transport Tests	8-14
REW/BOT	4-32		
Rewind	2-10	Unload	2-10
Rewind (REW)	4-32	Unload/Load	8-14
Rewind and Unload (RUN)	4-32	Upper Swing Arm Assembly	
Rewind/Unload Key	2-5	Replacement	7-11
Rewinding Status (REWS)	4-19	Upper Swing Arm Tach	
Rollers Cleaning	2-11	Assembly Replacement	7-13
RUN/BOT	4-32		
		Vacuum Blower Replacement	7-21
Select Indicator	2-2	Vertical Mount	3-6
Select Multiplex (SLXx)	4-8		
Sense Drive Status (SNS)	4-33	Write a Data Block (WRT)	4-25
Servo System (SV Card)	5-12	Write Card Status	8-10
Servo-LSI Register Loop	8-9	Write Data Path (DP Card)	5-1
Shoeshine Motion	8-3	Write Drivers (WR Card)	5-5
Skew Adjustment	6-5	Write Status (WRTS)	4-18
Slave Status Change (SSC)	4-11	Write Tape Mark (WTM)	4-30
Specifications	1-5	WRT/BOT	4-27
Start/Stop Motion	8-4	WTM/BOT	4-31
Status A Display	8-6		
Status B Display	8-6		
Status C Display	8-6		
Status Buffers	8-2		

(INTENTIONALLY LEFT BLANK)

READER'S COMMENT FORM

Please check or fill in the items; adding explanations/comments in the space provided.

Which of the following terms best describes your job?

- | | | | |
|---|--|---|--|
| <input type="checkbox"/> Field Engineer | <input type="checkbox"/> Manager | <input type="checkbox"/> Programmer | <input type="checkbox"/> Systems Analyst |
| <input type="checkbox"/> Engineer | <input type="checkbox"/> Mathematician | <input type="checkbox"/> Sales Representative | <input type="checkbox"/> Systems Engineer |
| <input type="checkbox"/> Instructor | <input type="checkbox"/> Operator | <input type="checkbox"/> Student/Trainee | <input type="checkbox"/> Other (explain below) |

How did you use this publication?

- | | | | |
|--|---|-----------------------------------|--|
| <input type="checkbox"/> Introductory text | <input type="checkbox"/> Reference manual | <input type="checkbox"/> Student/ | <input type="checkbox"/> Instructor text |
| <input type="checkbox"/> Other (explain) _____ | | | |

Did you find the material easy to read and understand? Yes No (explain below)

Did you find the material organized for convenient use? Yes No (explain below)

Specific criticisms (explain below)

Clarifications on pages _____

Additions on pages _____

Deletions of pages _____

Errors on pages _____

Explanations and other comments:

(If at all possible, mark-up copies of the problem manual pages and return those with this form.)

Note: Staples can cause problems with automated mail sorting equipment. Please use pressure sensitive or other gummed tape to seal this form. If you would like a reply, please supply your name and address on the reverse side of this form.

Thank you for your cooperation. No postage stamp necessary if mailed in the U.S.A.

YOUR COMMENTS PLEASE

Your constructive criticism can help us produce better publications in the future. This form may be used to communicate your views about this publication. Provide specific page and line references where they are appropriate.

STC shall have the nonexclusive right, at its discretion to use and distribute all submitted information, in any form, for any and all purposes, without obligation of any kind to the submitter. Your interest is appreciated.

FOLD AND TAPE

DO NOT STAPLE

FOLD



NO POSTAGE
NECESSARY
IF MAILED
IN THE
UNITED STATES

BUSINESS REPLY CARD
FIRST CLASS PERMIT NO 2 LOUISVILLE, CO U S A

POSTAGE WILL BE PAID BY ADDRESSEE

Storage Technology Corporation
2270 South 88th Street
Louisville, Colorado 80028



Attn: Tape/Disk Technical Publications M.D. 97

FOLD

DO NOT STAPLE

FOLD

If you would like a reply, please print:

Your Name: _____
Company Name: _____ Department: _____
Street Address: _____
City: _____
State: _____ Zip Code: _____

**2920
Tape
Subsystem**

**Illustrated Parts
Catalog**

PN 95522

Information contained in this publication is subject to change. In the event of changes, the publication will be revised. Comments or questions concerning this manual should be directed to Tape/Disk Technical Publications at the address below. A prepaid Reader's Comment Form is provided at the back of the manual.

This publication was prepared by Storage Technology Corporation, Tape/Disk Technical Publications, MD 97, 2270 South 88th Street, Louisville, Colorado 80028.

Warning: This equipment generates, uses, and can radiate radio frequency energy and if not installed and used in accordance with the instruction manual, may cause interference to radio communications. It has been tested and found to comply with the limits for Class A computing devices pursuant to Subpart J of Part 15 of FCC Rules, which are designed to provide reasonable protection against such interference when operated in a commercial environment. Operation of this equipment in a residential area is likely to cause interference in which case the user, at his own expense, will be required to take whatever measures may be required to correct the interference.

Copyright © 1984
by
Storage Technology Corporation
All Rights Reserved

LIST OF EFFECTIVE PAGES

Publication No. 95522

Issue Date: August 1983 EC NO. 49288

Change Date: June 1984 Change 15 Kit PN 97611

Incorporates ECs: 49533, 49554m, 43346

Total number of pages in this document is 30, consisting of the following pages:

PAGE	EC NO.	KIT PN	DISPOSITION
Cover	EC 49533	97611	REPLACE
Copyright	EC 49123	94862	
iii	EC 49533	97611	REPLACE
iv	EC 49339	NONE	
v	EC 49464	94962	
vi	EC 49339	NONE	
vii thru ix	EC 49288	NONE	
x	EC 49288	NONE	
1	EC 49288	NONE	
2	EC 49533	97611	REPLACE
3	EC 49533	97611	REPLACE
4	EC 49533	97611	REPLACE
5	EC 49533	97611	REPLACE
6	EC 49533	97611	REPLACE
7	EC 49464	94962	
8	EC 49464	94962	
9	EC 49495	97546	
10	EC 49495	97546	
11	EC 43346	94951	REPLACE
12	EC 49533	97611	REPLACE
13	EC 49533	97611	REPLACE
14	EC 49533	97611	REPLACE
15	EC 49464	94962	
16	EC 49372	94795	
17	EC 49533	97611	REPLACE
18	EC 49533	97611	REPLACE
Reader's Comment Form			
Business Reply Mailer			

95522LOE

95522

EC 49533
KIT PN 97611

iii

(INTENTIONALLY LEFT BLANK)

TABLE OF CONTENTS

Figure	Title	Page
	HOW TO USE ILLUSTRATED PARTS CATALOG	vii
1	Cover Group.	2
2	Basic Assembly, 292X Tape Subsystem.	4
3	Fan Assembly	15
4	Blower Assembly.	16
	NUMERICAL INDEX.	17
	Reader's Comment Form	
	Business Reply Mailer	

(INTENTIONALLY LEFT BLANK)

HOW TO USE THE ILLUSTRATED PARTS CATALOG

GENERAL

Illustrations always precede their parts lists and when possible, appear on the facing page; multipage illustrations and parts lists are exceptions. Blank pages are numbered on the printed side only.

The first number in each list identifies the figure in which the listed parts are shown (Arrow 1). The index numbers (Arrow 2) key the parts in the figures to the related information in the list. On subsequent pages of the same list, the first line repeats the figure number and gives the index of the next item listed (Arrow 3).

Figure Index Number	Part Number	1	2	3	4	Description
12-REF	300262905-7					FACEPLATE ASSEMBLY, 60 HZ
12-REF	300691301-1					FACEPLATE ASSEMBLY, 50 HZ (REFER TO FIGURE 11-1 FOR NHA)
9-REF	300303806-8					OP PANEL ASSY, DUAL DIRECTOR
9-REF	300654505-1					OP PANEL ASSY, QUAD DIRECTOR (REFER TO FIGURE 2-12 FOR NHA)
32	300262706-9					CHASSIS ASSEMBLY, 60 HZ

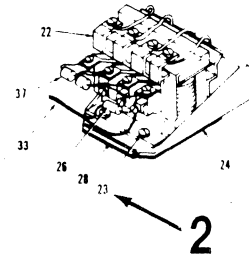

The figure numbers and assemblies follow a logical sequence of breakdown. If an assembly is further detailed elsewhere in this catalog, the figure is referenced in the description column (Arrow 4).

Figure Index Number	Part Number	1	2	3	4	Description	Usable on Code	Qty per Asm
11-REF	300201007-6					AC POWER SUPPLY ASSY, 60 HZ	A	1
11-REF	300201102-5					AC POWER SUPPLY ASSY, 50 HZ (REFER TO FIGURE 2-10 FOR NHA)	B	1
-1	300262905-7					FACEPLATE ASSY, 60 HZ	A	1
-1	300691301-0					FACEPLATE ASSY, 50 HZ (REFER TO FIGURE 12 FOR DETAILS)	B	1

Detailed figures refer back to the next higher overall view or next higher assembly (NHA) (Arrow 5). Assemblies that are not detailed can be ordered only as complete assemblies.

A detail part may be unlisted for several reasons; it is part of a matched set, part of an assembly that is purchased as a unit, or part of a welded or bonded assembly. If you need an unlisted part, you must order the assembly that contains it, and not the detailed part.

LEVEL OF ASSEMBLY

The indented parts list indicates the subordination of major assemblies, subassemblies and detail parts. Attaching hardware normally follows the detail part. The top assembly (figure number) in each parts list is level 1 (Arrow 6). Descriptions preceded by a single dot (.) (Arrow 7) are second level assemblies or details which are subordinate to those not preceded by a dot. Descriptions for levels 3 and 4 are preceded by two dots "...", are subordinate to level 2, or those preceded by one dot (Arrow 8).

Figure Index Number	Part Number	Description	Usable on Code	Qty per Asm
7-REF	510252202-5	CARD CAGE ASSY,CACHE MEM	A	1
-1	510205602-4	CARD CAGE SUB ASM-CACHE MEM	B	1
-2	510209202-9	..COVER,CD CAGE ASSY,CACHE	A	1
-3	510236902-1	...B/P,TAPE & TRAY ASSY,CACHE	A	1
-4	10075080-1	...CA-CLP,P,RT ANGLE TIE MOUNT	B	1
-5	10011026-1	...SCREW,MACH,SBNC.6-32 X 3/8, PS	A	12
-6	10092020-6	...WSHR,FLAT,N,.156 ID X .312 X .032T		11

USABLE ON CODE

Usable On Code identifies all related parts (Arrow 9). The code relationships are explained at the beginning of each list (Arrow 10). If there is no code identified, the specific part is interchangeable with all codes.

NUMERICAL INDEX

The numerical index lists all part numbers in numerical order. The part number is cross referenced to each figure and index number where the part can be found in the catalog. For example (Arrow 11): Part No. 10073244-5 can be found on Figure 24, Index No. 41.

FIGURE & INDEX NUMBER	PART NUMBER	FIGURE & INDEX NUMBER	PART NUMBER	FIGURE & INDEX NUMBER	PART NUMBER
16-8	10030526-8	18-1	10054146-5	24-41	10073244-5
20-4	10037012-1	19-35	10056010-1	24-49	10073267-6
4-5	10037013-9	19-36	10056014-3	24-44	10073278-3
5-2	10037013-9	19-30	10056023-4	24-67	10073282-5

11

CHANGE BARS

A Change Bar (Arrow 12) indicates latest revision of a parts list. These are changes that have occurred since the last issue date of the IPC.

12

-5	10077118-7	.CIRCUIT BREAKER, T, 1P, PO, 3A, 277V	A	1
-6	10077117-9	.CIRCUIT BREAKER, T, 2P, PO, 6A, 277V		5
-7	10077130-2	.CIRCUIT BREAKER, T, 5A, PO, 250 VAC	A	1

PART NUMBER COMPATIBILITY LIST

Whenever (PN COMP) (Arrow 13) appears in the part number column, refer to the machine part number compatibility list for the latest part number.

1.2-12	62001098-3	.. SHOULDER WASHER PHEN NO. 10	4
1.2-13	(PN COMP)	.. CARD SET, FE	1
1.2-14	10013061-6	.. SCREW, MACH, SBNH, 10-32 X .312	4
1.2-15	62001058-7	.. SLIDE, FD, 2 PHASE	1

13

(INTENTIONALLY LEFT BLANK)

2920 ILLUSTRATED PARTS CATALOG
1983

PN 95522

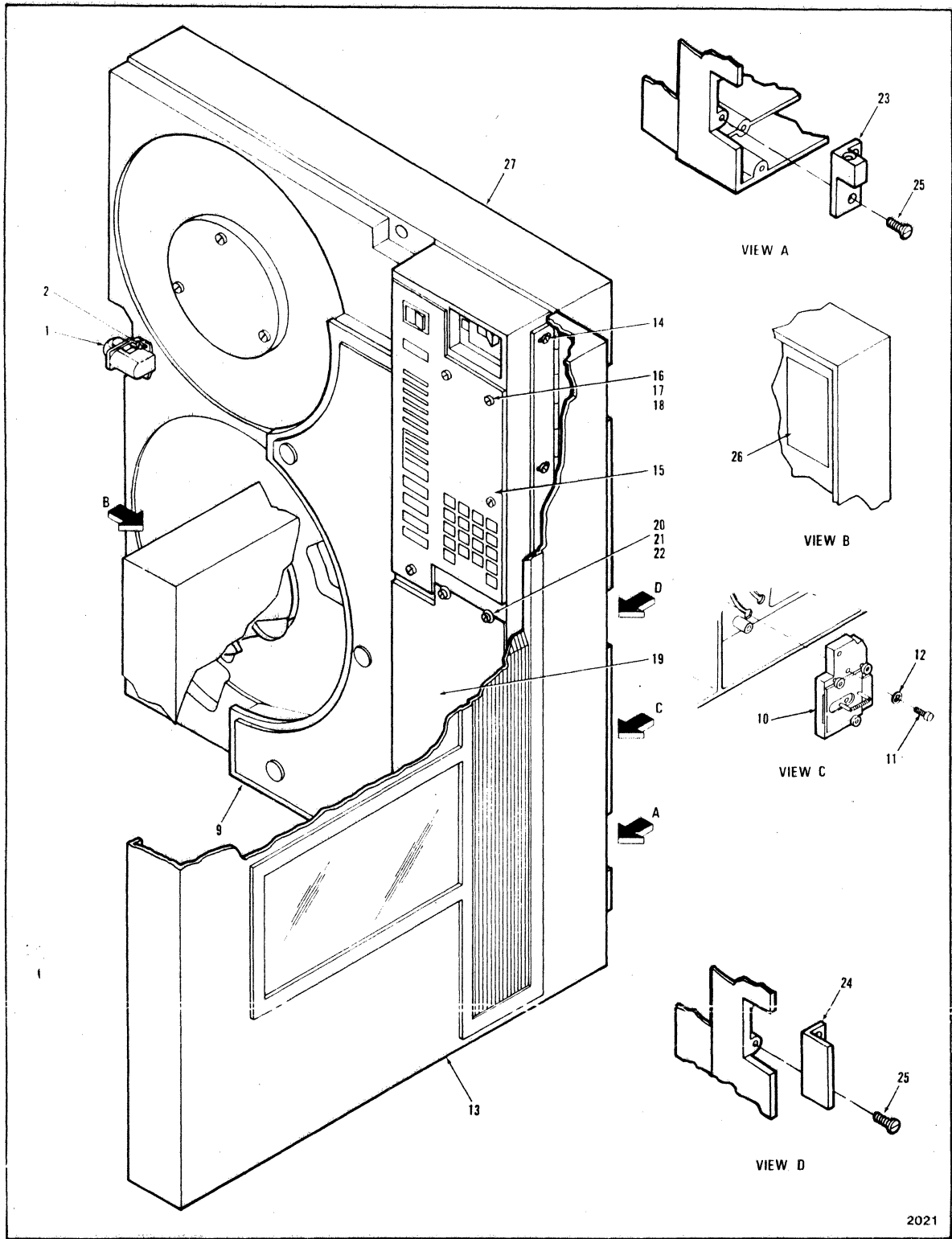

2021

FIGURE 1. COVER GROUP

Figure Index Number	Part Number	Description				Usable on Code	Qty per Asm
		1	2	3	4		
1 -							
				.DELETED			
				.DELETED			
	403470301			COVER GROUP,BASIC,V			1
	403467401			HORIZONTAL MOUNTING GROUP (SPR)			1
-1	403242501-1			.CATCH,DOOR			1
-2	10013015-2			.SCREW,MACH,SBNH,4-40 X .500,PS			2
	402457901-3			.VERTICAL MOUNTING GROUP (SPR)			1
				.DELETED			
-3				.DELETED			
-4				.DELETED			
-5				.DELETED			
-6				.DELETED			
-7				.DELETED			
-8				.DELETED			
-9	402336904			..COVER ASSEMBLY,THREAD (SPR)			1
	403440102			..COVER ASSEMBLY,THREAD (SPR)			1
	403440901-3			..VERTICAL VACUUM SEAL (SPR)			1
-10	402624902-1			...MUD FLAP ASSEMBLY (SPR)			1
-11	10007028-3			...SCREW,SHC,6-32 X .625 (SPR)			3
-12	10030514-3			...WASHER,LOCK,INT NO.6 (SPR)			3
-13	403274403-1			.DOOR ASSEMBLY,FRONT (SPR)			1
	403437701			.DOOR ASSY,FRONT			1
-14	10203008-7			.SCREW,RF,TXPH,SEM,6-32 X .37 (SPR)			5
-15	402337202-4			.OPERATOR PANEL ASSEMBLY (SPR)			1
	403386202-2			.SWITCH PANEL ASSEMBLY (SPR)			1
-16	10096028-5			.SCREW,MACH,SBNH,6-32 X .437,BO (SPR)			4
-17	10096070-7			.WASHER,LOCK,SPLIT,NO. 6,BO (SPR)			4
-18	10096055-8			.WASHER,FLAT,NO. 6			4
-19	402341104-6			.PLATE ASSEMBLY,CARD CAGE (SPR)			1
-20	10096028-5			.SCREW,MACH,SBNH,6-32 X .437,BO (SPR)			4
-21	10096070-7			.WASHER,LOCK,SPLIT,NO. 6,BO (SPR)			4
-22	10096055-8			.WASHER,FLAT,NO. 6 (SPR)			4
	403420101-4			.HINGE GROUP,BASIC (SPR)			1
-23	403456801-6			..HINGE,HALF,DECK (SPR)			2
-24	403434502-7			..BRACKET,CLOSURE (SPR)			1
-25	10203024-4			..SCREW,RF,TXPH,SEM,10-32 X .625 (SPR)			6
-26	403482601			.LABEL,TAPE PATH (SPR)			1
-27	402336502-8			.BASIC ASSEMBLY,292X TAPE (SPR)			1
				.DELETED			
	403467301			BASIC ASSEMBLY, 292X MTS (SEE FIG 2 FOR DETAILS)			1

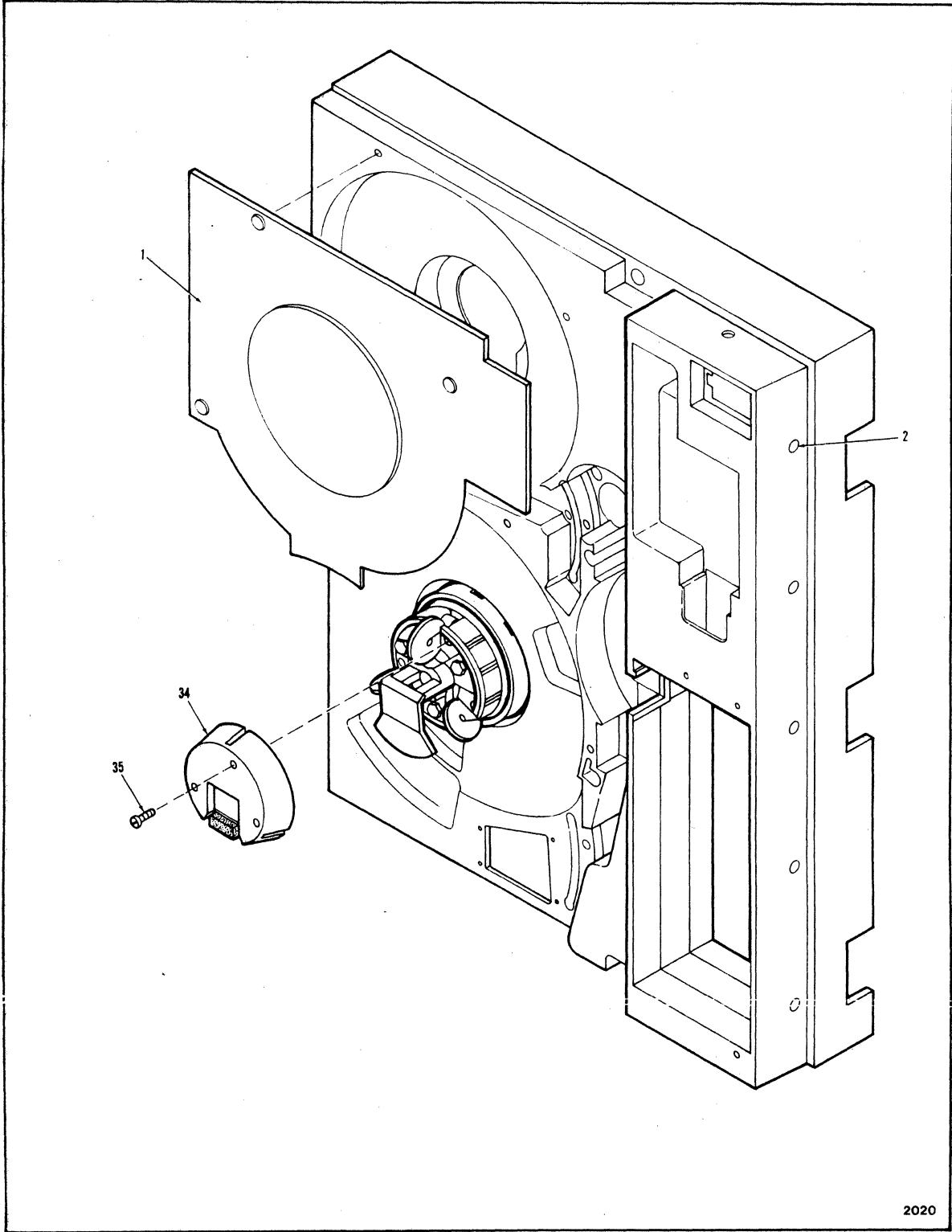

FIGURE 2. BASIC ASSEMBLY, 292X TAPE SUBSYSTEM (SHEET 1 OF 7)

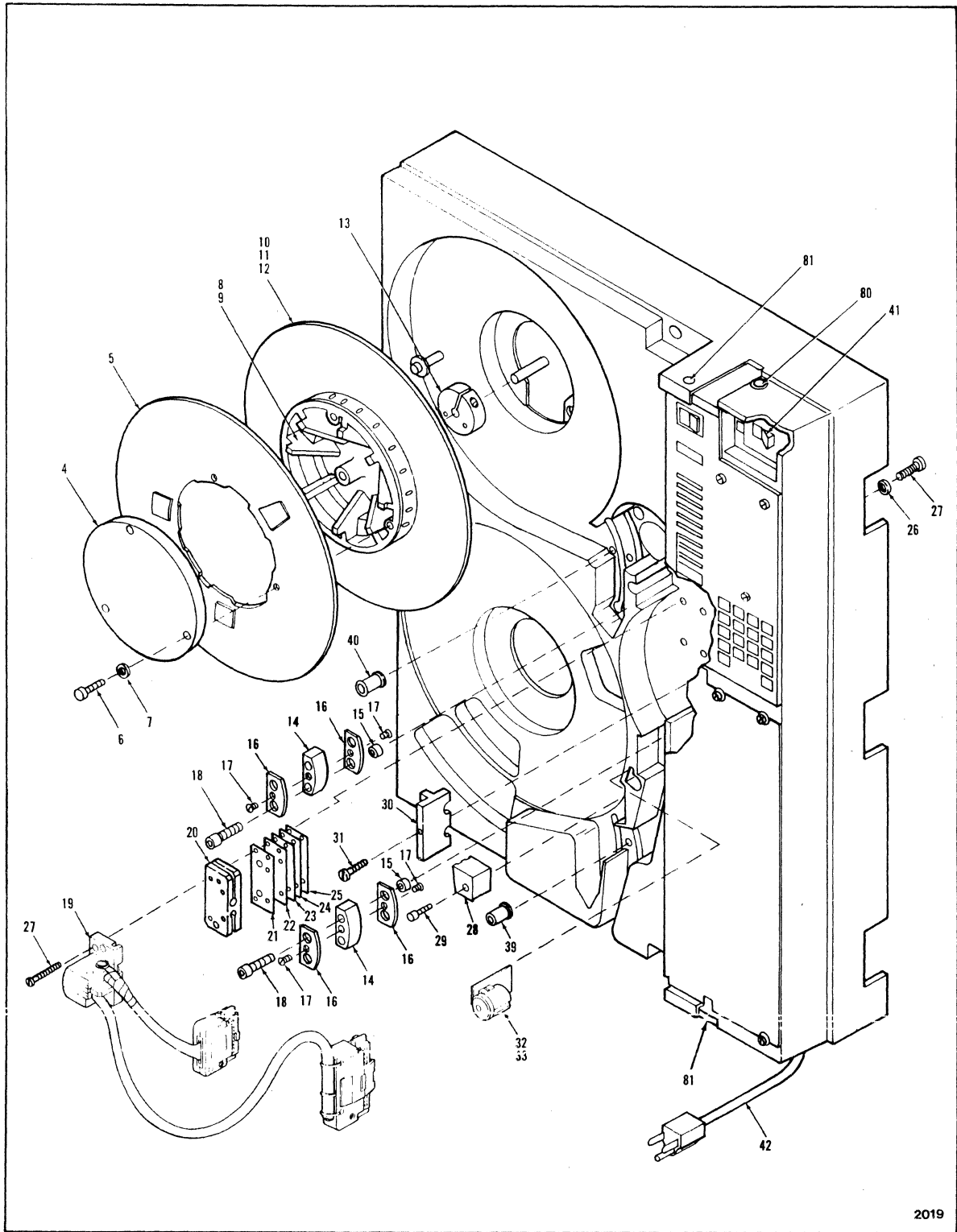
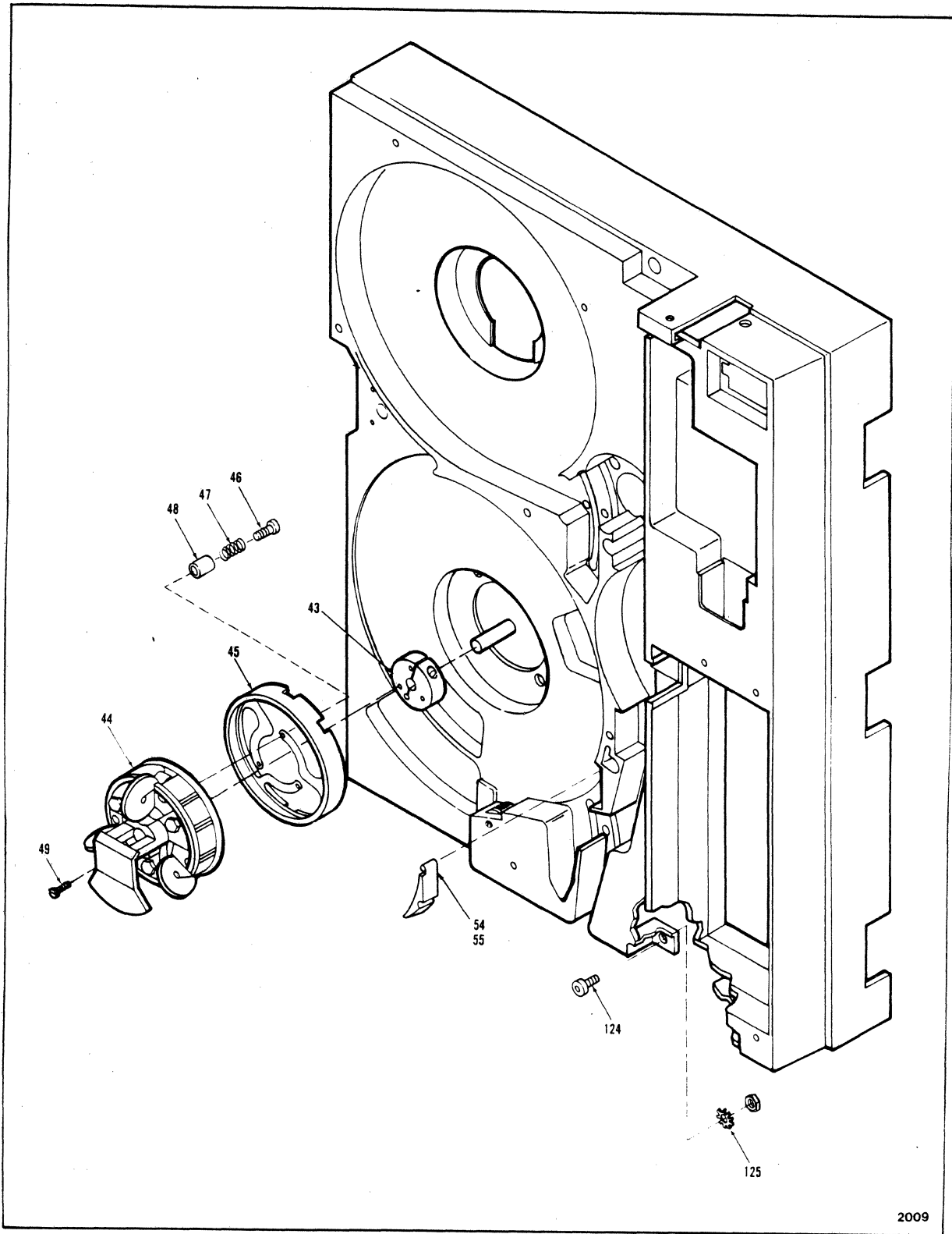
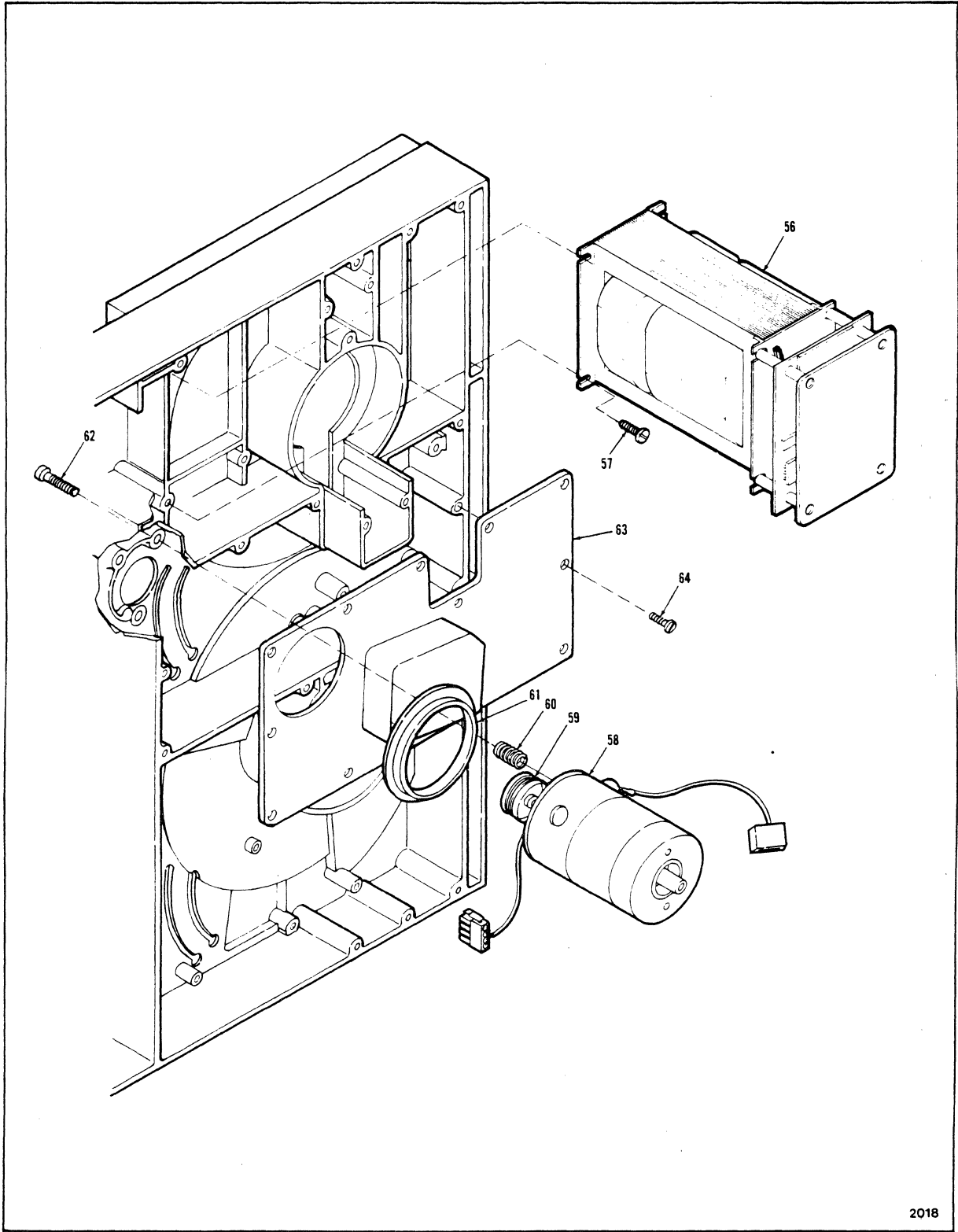

FIGURE 2. BASIC ASSEMBLY, 292X TAPE SUBSYSTEM (SHEET 2 OF 7)



2009

FIGURE 2. BASIC ASSEMBLY, 292X TAPE SUBSYSTEM (SHEET 3 OF 7)



2018

FIGURE 2. BASIC ASSEMBLY .292X TAPE SUBSYSTEM (SHEET 4 OF 7)

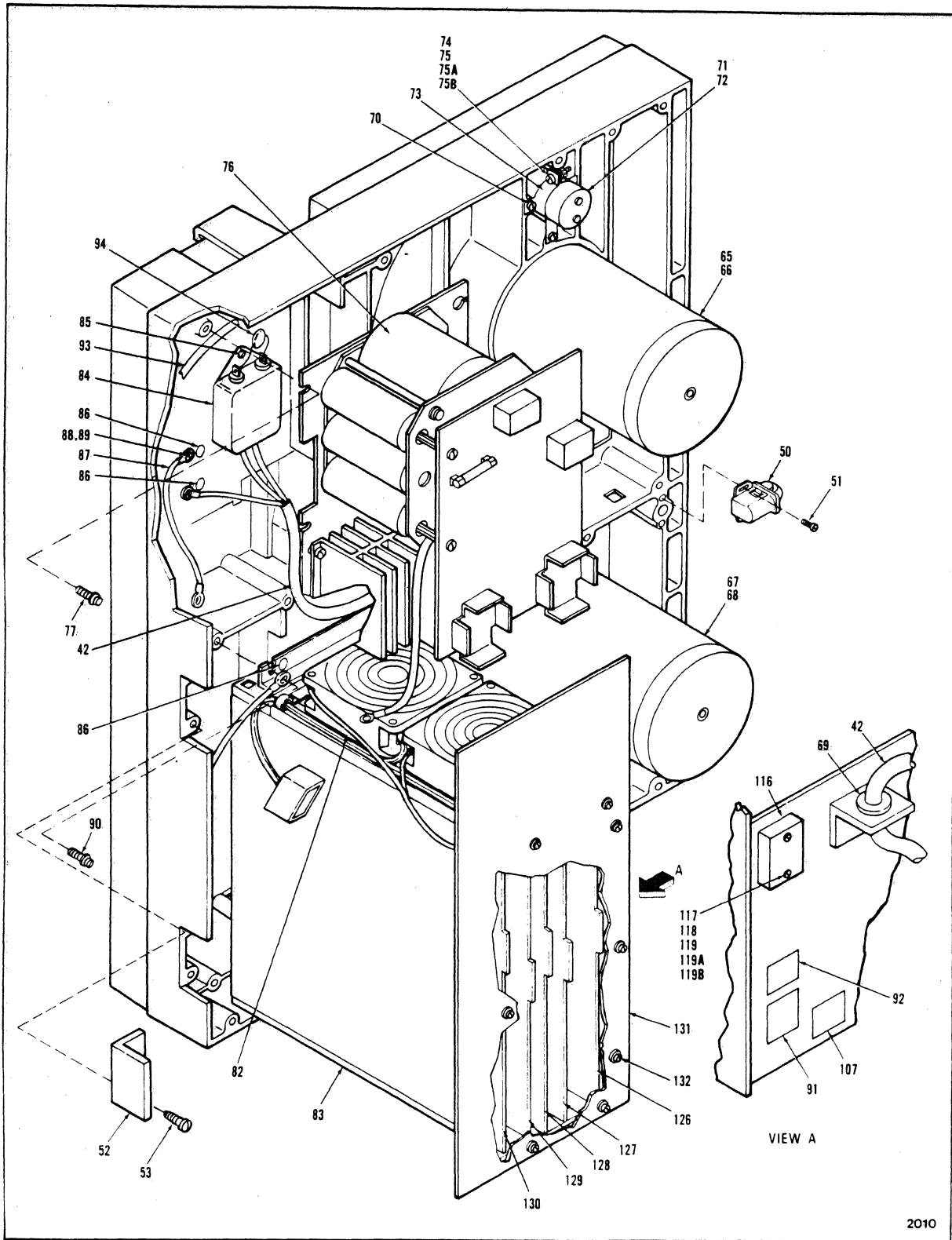

2010

FIGURE 2. BASIC ASSEMBLY, 292X TAPE SUBSYSTEM (SHEET 5 OF 7)

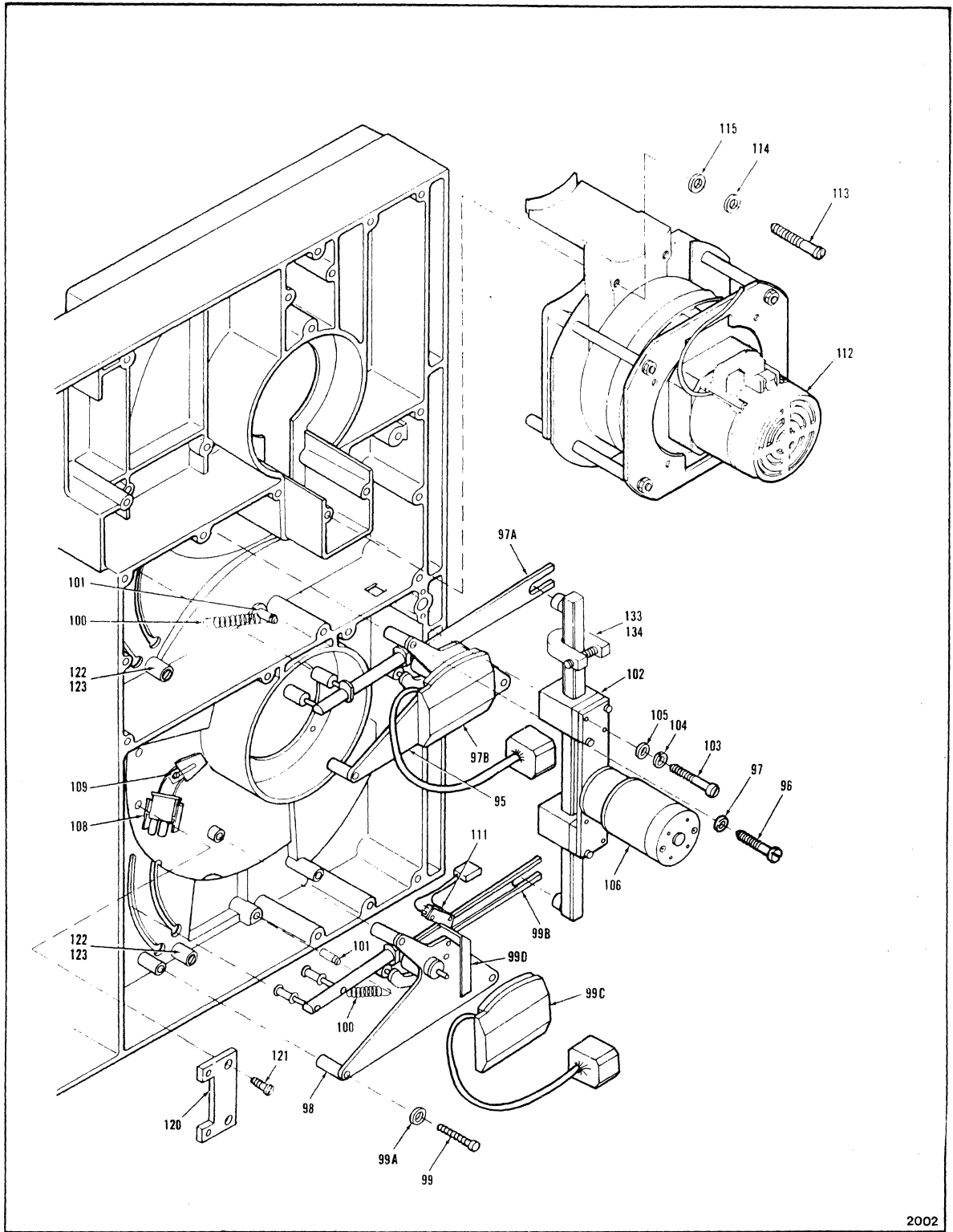
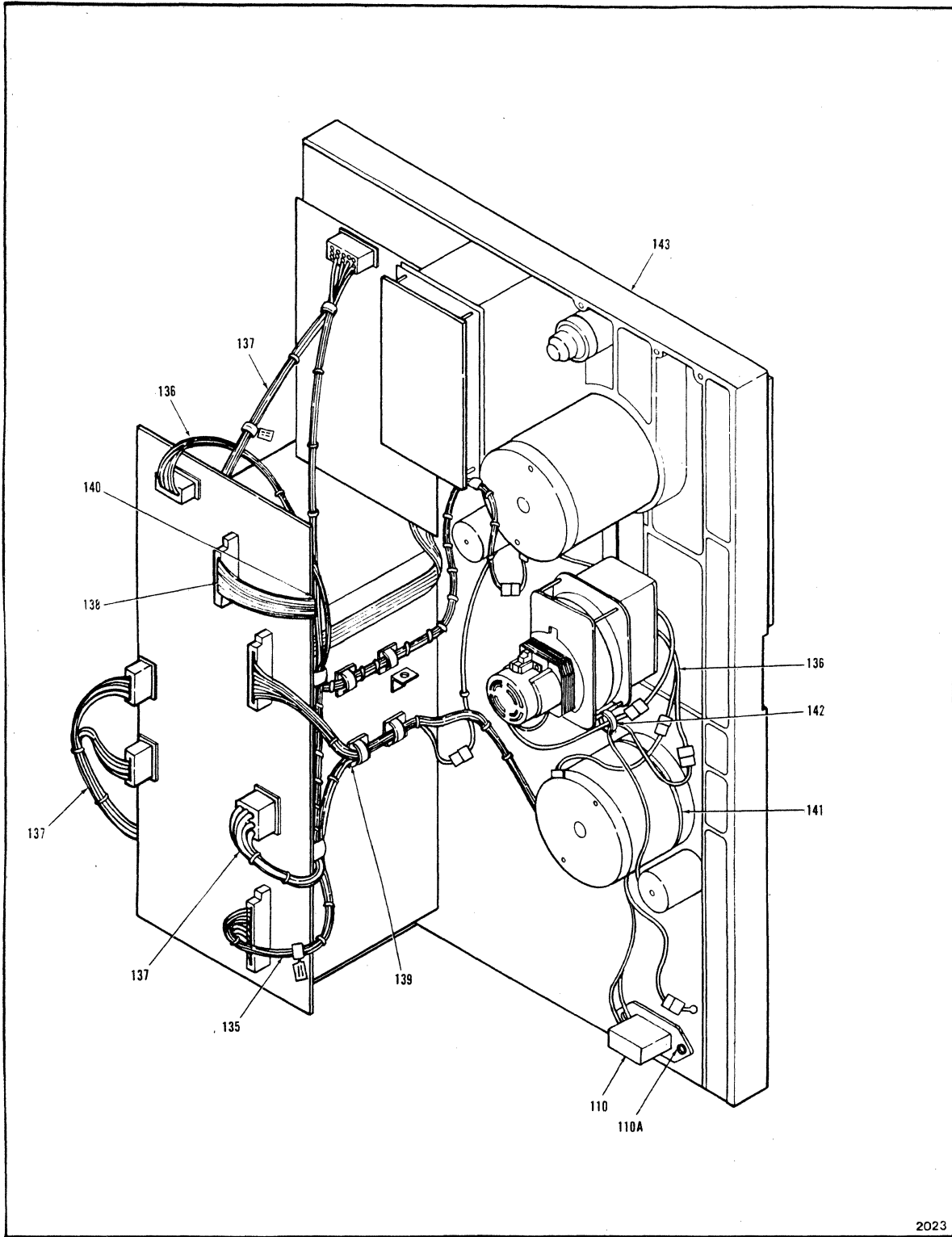

FIGURE 2. BASIC ASSEMBLY, 292X TAPE SUBSYSTEM (SHEET 6 OF 7)



2023

I FIGURE 2. BASIC ASSEMBLY, 292X TAPE SUBSYSTEM (SHEET 7 OF 7)

Figure Index Number	Part Number	Description				Usable on Code	Qty per Asm
		1	2	3	4		
2 -		.DELETED					
		.DELETED					
	403467301	BASIC ASSEMBLY, 292X MTS (SEE FIGURE 1-27 FOR NHA)					1
-1	402370902-7	.COVER ASSEMBLY, SEAL					1
-2	403455001	CLIP, SNAP IN (SPR)					5
-3		.DELETED					
-4	42420324-8	.CAP, HUB					1
-5	403442801-3	.FLANGE, FRONT, AUTO LOAD					1
-6	10096304-0	.SCREW, MACHINE, SHC, 10-32X.625					3
-7	10030505-1	.WASHER, LOCK, NO. 10					3
-8	401209304-5	.FLANGE, REAR, MACHINE REEL (SPR)					1
	403488601	.FLANGE, REAR, MACHINE REEL					1
-9	10013012-9	.SCREW, MACH, SBNH, 4-40 X .250					6
-10	402339302-0	.HUB, TAKEUP REEL					1
-11	10007027-5	.SCREW, MACH, SHC, 6-32 X.500, PS					3
-12	10030503-6	.WASHER, LOCK, HEL, MED, PS, NO.6					3
-13	402573701-8	.COLLAR, MOUNTING					1
-14	402338907-7	.BEARING, GUIDE					2
-15	403012302-2	.BUSHING, GUIDE BEARING					4
-16	402339006-7	.FLANGE, GUIDE BEARING					4
-17	10011024-5	.SCREW, MACH, BHC, PS, 6-32X.250					4
-18	403391101-9	.SCREW, SHOULDER GUIDE					4
-19	402606602-9	.CERAMIC R/W HEAD ASSY					1
-20	402603702-2	.SKEW BLOCK ASSEMBLY					1
-21	402390702-7	.SHIM, SKEW, .001					1
-22	402390802-5	.SHIM, SKEW, .002					1
-23	402390902-3	.SHIM, SKEW, .004					1
-24	402391002-1	.SHIM, SKEW, .006					1
-25	402390002-2	.SHIM, SKEW, .010					1
-26	10030503-6	.WASHER, LOCK, HEL, MED, PS, NO.6					4
-27	10007026-7	.SCREW, MACH, SBNH, 6-32 X .375, PS					7
-28	00002708-6	.CLEANER ASSEMBLY					1
-29	10008031-6	.SCREW, SCH, 6-32 X 1.0					1
-30	403480001	.FILLER, BLOCK ASSEMBLY (SPR)					1
	403491804	.FILLER, BLOCK ASSEMBLY					1
-31	10007020-0	.SCREW, MACHINE, SHC, 4-40 X 1.250, PS					1
-32	(PN COMP)	.EOT/BOT ASSEMBLY					1
-33	10007202-4	.SCREW, MACH, SHC, 4-40 X 1.00, PS					2
-34	403375701	.HUB CAP, HIGH SPEED HUB					1
-35	10007202-4	.SCREW, MACH, SHC 4-40 X 1					3
-36		.DELETED					
-37		.DELETED					
-38		.DELETED					
-39	402552003-4	.ROLLER ASSEMBLY, CROWNED					1
-40	402336703-2	.ROLLER ASSEMBLY, FLANGED					2

Figure Index Number	Part Number	Description				Usable on Code	Qty per Asm
		1	2	3	4		
2-							
-41	403245602-4	.CIRCUIT BREAKER ASSY,10AMP					1
	403245601-6	.CIRCUIT BREAKER ASSY,7.5AMP					1
-42	402339803-7	.CORD, POWER					1
-43	402573701-8	.COLLAR, MOUNTING					1
	403375301-5	.FILE PROTECT ASSEMBLY					1
-44	401292309-2	.FILE HUB SUBASSY, MANUAL					1
-45	403376601-7	.RING,FILE PROTECT					1
-46	10204013-6	.SCREW, TXPH, 6-19 X .625					3
-47	403375201-7	.SPRING, FILE PROTECT					3
-48	403376501-9	.BUSHING, FILE PROTECT					3
-49	10007202-4	.SCREW, MACHINE, SHC, 4-40X1					3
-50	403076701-8	.LATCH, DECK, MOD					1
-51	10203009-5	.SCREW, TF, TXPH, SEM, 6-32 X .50					2
-52	403434502-7	.BRACKET, CLOSURE (SPR)					1
-53	10203024-4	.SCREW, RF, TXPH, SEM, 0-32 X .500 (SPR)					2
-54	403271402	.DIVERTER, ASSEMBLY, THREADING (SPR)					1
	403479701	.DIVERTER, ASSEMBLY, THREADING					1
-55	10090005-9	.RING, RETAINING, EXT, .125					1
-56	402573502	.TRANSFORMER, PK ASSY, 60 HZ					1
	403255502	.TRANSFORMER, PK ASSY, 50 HZ					1
-57	10203030-1	.SCREW, TF, TXPH, SEM, 1/4-20 X .50					4
	402271201-4	.MOTOR ASSEMBLY, CAPSTAN					1
-58	402338302-1	.MOTOR, CAPSTAN					1
-59	402338401-1	.WHEEL, CAPSTAN					1
-60	403199301-9	.SPRING, MOTOR					3
-61	402383102-9	.SEAL, CAPSTAN MOTOR					1
-62	403125302-8	.SCREW, SOCKET HEAD CAP					3
-63	402553003-3	.COVER ASSEMBLY, REAR					1
-64	10203024-4	.SCREW, TF, TXPH, SEM, 10-32 X .62					12
-65	402271402-8	.MOTOR ASSEMBLY, REEL					1
-66	10203024-4	.SCREW, TF, TXPH, SEM, 10-32 X .62					4
-67	402271301-2	.MOTOR ASSEMBLY, FILE REEL					1
-68	10203024-4	.SCREW, TF, TXPH, SEM, 10-32 X .62					4
-69	10097203-3	.BUSHING, STRAIN RELIEF					1
	403257203-6	.CAPACITOR, INSULATED, 6-UF, 660V					1
-70	10203009-5	.SCREW, TF, TXPH, SEM, 6-32X.500					3
-71	10049017-6	.CAP, OIL, 6%, 660V, 6UF, NON PCB					1
-72	10057075-3	.TUBE, EL, SHRINK, 2100/1.00, IEC					AR
-73	403370503-1	.BRACKET, CAPACITOR					1
-74	10203009-5	.SCREW, TF, TXPH, SEM, 6-32X.500					1
-75	10027019-8	.WASHER, FLAT, B, NO.6, N					1
-75A	10030503-6	.WASHER, LOCK, HEL, MED, PS, NO.6					1
-75B	10028003-1	.NUT, HEX, 6-32					1
-76	420337101-8	.REGULATOR ASSEMBLY					1
-77	10203024-4	.SCREW, TF, TXPH, SEM, 10-32X.625					4
-78		.DELETED					
-79		.DELETED					

Figure Index Number	Part Number	Description				Usable on Code	Qty per Asm
		1	2	3	4		
2-							
-80					.DELETED		
-81	10096522-7				.PIN, 3 ORV (SPR)		2
-82	403777502-2				.FAN ASSEMBLY (SEE FIGURE 3 FOR DETAILS)		1
-83	402336802-2				.CARD CAGE ASSEMBLY		1
-84	10058118-0				.FILTER, LINE, 10A, 250V		1
-85	10203008-7				.SCREW, TF, TXPH, SEM, 6-32 X .375		3
-86	00029526-1				.DECAL, GROUND LOCATION		3
-87	403198201-2				.CABLE ASSY, GROUND DECK TO FRAME		1
-88	10203024-4				.SCREW, TF, TXPH, SEMS, 10-32 X .625		1
-89	10030522-6				.WASHER, LOCK, EXT, MED, PS, NO. 10		1
-90	10203024-4				.SCREW, TF, TXPH, SEM, 10-32 X .625		4
-91	42420904-7				.LABEL, UL HIPOT TEST		1
-92	50050023-6				.STICKER, MODIFICATION, V1 AND V2		1
-93	403215501-4				.CABLE HARNESS, AC		1
-94	402584501-9				.VARISTOR ASSEMBLY		1
-95	402560105-7				.SWING ARM ASSEMBLY, UPPER		1
-96	100007032-5				.SCREW, MACH, SHC, 6-32 X .250		3
-97	10030503-6				.WASHER, LOCK, HEL, MED, PS, NO. 6		3
-97A	403123903-3				.RETRACTOR ARM ASSEMBLY		1
-97B	402339403-6				.ENCODER, SWING ARM		1
-98	402560205-5				.SWING ARM ASSEMBLY, LOWER		1
-99	10007032-5				.SCREW, MACH, SHC, 6-32 X .250		3
-99A	10030503-6				.WASHER, LOCK, HEL, MED, PS, NO. 6		3
-99B	403123903-3				.RETRACTOR ARM ASSEMBLY		1
-99C	402339403-6				.ENCODER, SWING ARM		1
-99D	403156902-5				.RETRACTOR SWITCH ASSEMBLY		1
-100	403156501-5				.SPRING, TENSION		2
-101	10109515-6				.SPRING, POST, .187 DIA X .375		2
-102	403123802-7				.RETRACTOR ASSEMBLY		1
-103	10007035-8				.SCREW, MACHINE, SHC, 6-32 X 2.0		4
-104	10030503-6				.WASHER, LOCK, HEL, MED, PS, NO. 6		4
-105	10027019-8				.WASHER, FLAT, B, NO. 6, N		4
-106	403123501-5				.GENERATOR ASSEMBLY		1
-107	401599101-3				.LABEL, CONFIGURATION		1
-108	402637801-0				.SENSE ASSEMBLY, FILE PROTECT		1
-109	10013014-5				.SCREW, MACH, SBNH, 4-40 X .375 PS		1

Figure Index Number	Part Number	Description				Usable on Code	Qty per Asm
		1	2	3	4		
2-							
-110	403376302				. SWITCH ASSEMBLY, INTERLOCK		1
-110A	10007026				. SCREW, MACH, 6-32 X .375, PS		2
-111	400394301-8				. SWITCH, WINDOW (SPR)		1
-112	403219203				. BLOWER ASSEMBLY (SEE FIGURE 4 FOR DETAILS)		1
-113	10007070-5				. SCREW, MACH, SHC, 10-32 X 1.75, PS		4
-114	10030505-1				. WASHER, LOCK, HEL, MED, NO. 10, PS		4
-115	10026006-6				. WASHER, FLAT, A, NO. 10		4
-116	10078177-2				. RELAY, SS, PHOTO ISOL		1
-117	10028003-1				. NUT, HEX, 6-32		2
-118	10030503-6				. WASHER, LOCK, HEL, MED, NO. 6, PS		2
-119	10026004-1				. WASHER, FLAT, A, NO. 6		2
-119A	10030514-3				. WASHER, LOCK (SPR)		2
-119B	10030515-0				. WASHER, LOCK, NO.8 (SPR)		2
-120	403096301-3				. PLATE, MTG, EOT/BOT CONNECTOR		1
-121	10203008-7				. SCREW, TF, TXPH, SEM, 6-32 X .37		2
-122	403225601-0				. BUMPER, SWING ARM		2
-123	10203011-1				. SCREW, TF, TXPH, SEM, 6-32 X .75		2
-124	10410198-5				. CONNECTOR, BANANA PLUG, LOW PROFILE		1
-125	10030523-4				. WASHER, LOCK, EXT, MED, PS, .250		1
-126	(PN COMP)4				. CKT CD, SV, PC ASSEMBLY		1
-127	(PN COMP)4				. CKT CD, 1F, PC ASSEMBLY		1
-128	(PN COMP)4				. CKT CD, WR, PC ASSEMBLY		1
-129	(PN COMP)4				. CKT CD, DP, PC ASSEMBLY		1
-130	(PN COMP)4				. CKT CD, RD, PC ASSEMBLY		1
-131	(PN COMP)4				. CKT CD, MBD, PC ASSEMBLY		1
-132	10203024-4				. SCREW, TF, TXPH, SEM, 10-32 X .625		8
-133	403224702-7				. COLLAR, STOP		1
-134	10007067-1				. SCREW, MACH, SHC, 10-32 X 1		1
-135	402339602-6				. CABLE HARNESS SENSOR		1
-136	402375503-8				. CABLE HARNESS MOTORS		1
-137	402375602-8				. CABLE HARNESS POWER		1
-138	402610802-9				. CABLE ASSEMBLY, KEYBOARD (SPR)		1
-139	10075063-7				. CABLE CLAMP, ADJ/REL (SPR)		11
-140	10075105-6				. CABLE CLAMP, ADH BACK		1
-141	10075047-0				. CABLE CLAMP, T		1
-142	10075020				. CABLE TIE (SPR)		1
-143					. DELETED		
	403386501-1				. DECK ASSEMBLY, DOWELED (SPR)		1
	403437801				. DECK ASSEMBLY, DOWELED (SPR)		1

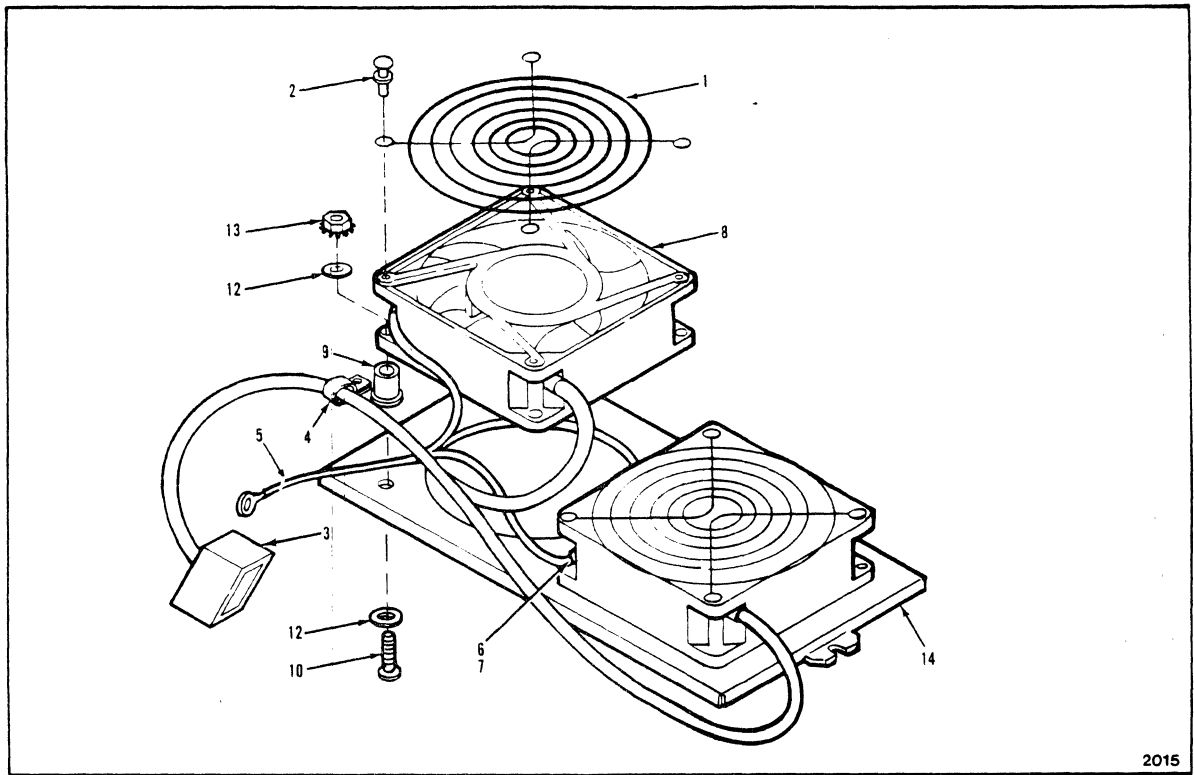
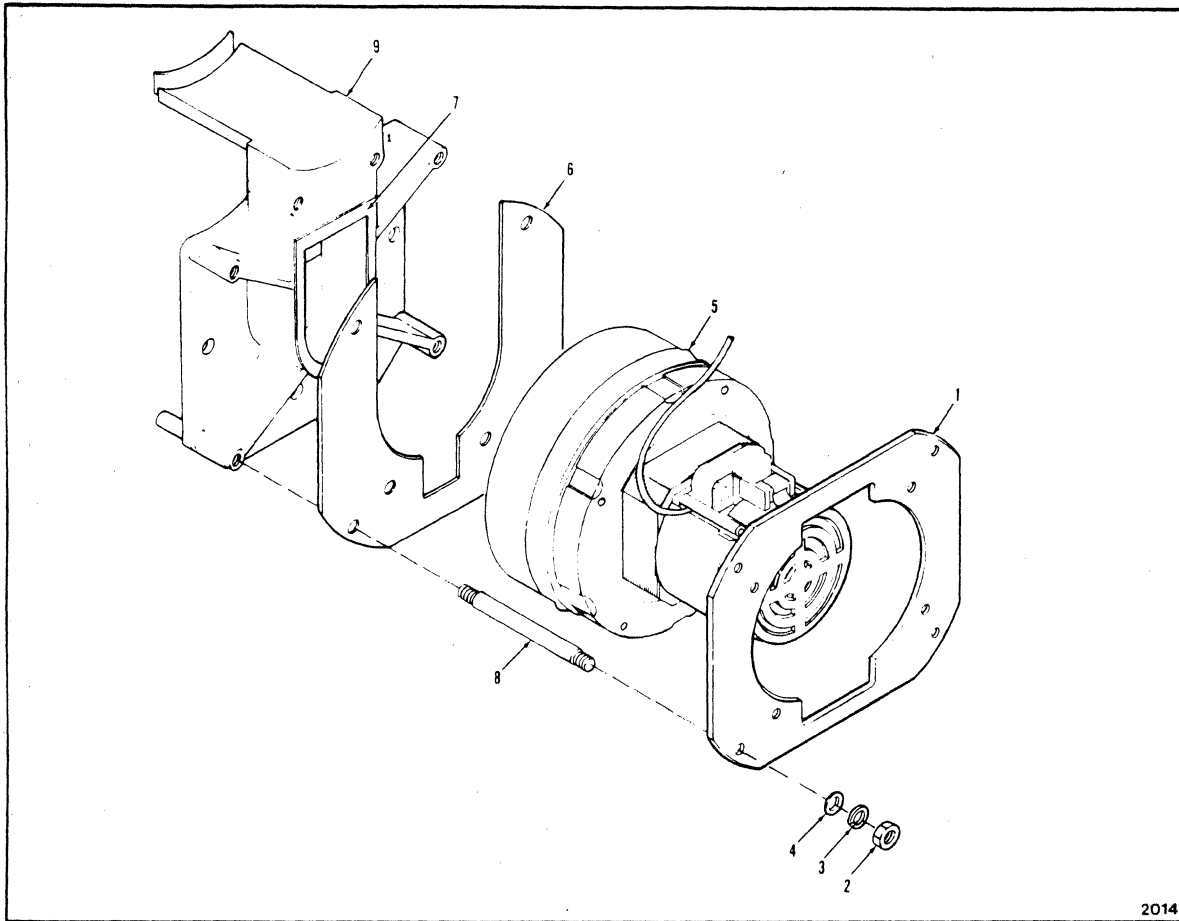

FIGURE 3. FAN ASSEMBLY

Figure Index Number	Part Number	Description				Usable on Code	Qty per Asm
		1	2	3	4		
3 -	403777502-2	FAN ASSEMBLY (SEE FIGURE 2-82 FOR NHA)					1
-1	10037062-6	.GUARD, FINGER					2
-2	403022502-5	.RIVET, SNAP					6
-3	403281602-9	.CABLE, POWER, FAN					1
-4	10075109-8	.CLAMP, CABLE					1
-5	403198301-0	.CABLE, GROUND					1
-6	10031010-3	.SCREW, SELF-TAP, SBNH, NO. 8					2
-7	10030515-0	.WASHER, LOCK, INT, STAR, NO. 8					2
-8	10037026-1	.FAN, AXIAL, 40CFM, 3.625, 115V					2
-9	403076801-6	.MOUNT, ISOLATOR					3
-10	10021029-3	.SCREW, HWH, 6-32 X .750, PS					6
-11		.DELETED					
-12	10026004-1	.WASHER, FLOAT, NO. 6					12
-13	10028058-5	.NUT, HEX, 6-32, KEPS					6
-14	402341004-8	.BRACKET, FAN MOUNTING					1



2014

FIGURE 4. BLOWER ASSEMBLY

Figure Index Number	Part Number	Description	Usable on Code				Qty per Asm
			1	2	3	4	
4 -	403219201-7	BLOWER ASSEMBLY (SEE FIGURE 2-112 FOR NHA)					1
- 1	402365501-4	.PLATE, BLOWER MOUNTING					1
- 2	10028006-4	.NUT, HEX, 10-32					4
- 3	10030505-1	.WASHER, LOCK, HEL. MED, NO. 10, PS					4
- 4	10026006-6	.WASHER, FLAT, A, NO. 10					4
- 5	403778201-0	.BLOWER SUBASSEMBLY, VACUUM					1
- 6	403287401-0	.PLATE, ADAPTER					1
- 7	402545304-6	.GASKET, BLOWER					1
- 8	403219101-9	.STUD, BLOWER ASSEMBLY					4
- 9	402340104-7	.ADAPTER, BLOWER					1

NUMERICAL INDEX

FIGURE & INDEX NUMBER	PART NUMBER	FIGURE & INDEX NUMBER	PART NUMBER	FIGURE & INDEX NUMBER	PART NUMBER
2-28	00002708	2-42	402339803	4-8	403219101
2-86	00029526	4-9	402340105	2-112	403219203
3-8	10037026	3-14	402341004	4-REF	403219201
3-1	10037062	1-19	402341104	2-133	403224702
2-71	10049017	4-1	402365501	2-122	403225601
2-72	10057075	2-1	402370902	1-1	403242501
2-84	10058118	2-136	402375503	2-41	403245601
2-142	10075020	2-137	402375602	2-41	403245602
2-141	10075047	2-61	402383102	2-56	403255502
2-139	10075063	2-25	402390002	2-54	403271402
2-140	10075105	2-21	402390702	1-13	403274403
3-4	10075109	2-22	402390802	3-3	403281602
2-116	10078177	2-23	402390902	4-6	403287401
2-55	10090005	2-24	402391002	2-73	403370503
2-37	10096478	4-7	402545304	2-47	403375201
2-38	10096479	2-39	402552003	2-REF	403375301
2-81	10096522	2-63	402553003	2-34	403375701
2-69	10097203	2-95	402560105	2-110	403376302
2-101	10109515	2-98	402560205	2-48	403376501
2-124	10410198	2-56	402573502	2-45	403376601
2-4	42420324	2-13	402573701	1-15	403386202
2-91	42420904	2-43	402573701	2-143	403386501
2-34	43430070	2-94	402584501	2-18	403391101
2-92	50050023	2-20	402603702	1-REF	403420101
2-111	400394301	2-19	402606602	2-5	403442801
2-8	401209304	2-138	402610802	2-52	403434502
2-44	401292309	1-10	402624902	1-24	403434502
2-107	401599101	2-108	402637801	1-13	403437701
2-REF	402271201	2-15	403012302	2-143	403437801
2-67	402271301	1-3	403022102	1-9	403440102
2-65	402271402	3-2	403022502	1-REF	403440901
1-27	402336502	2-50	403076701	2-5	403442801
2-40	402336703	3-9	403076801	2-2	403455001
2-83	402336802	2-120	403096301	1-23	403456801
1-9	402336904	2-106	403123501	1-27	403467301
1-15	402337202	2-102	403123802	2-REF	403467301
2-58	402338302	2-97A	403123903	1-REF	403467401
2-59	402338401	2-99B	403123903	1-REF	403470301
2-14	402338907	2-100	403156501	2-54	403479701
2-16	402339006	2-99D	403156902	2-30	403480001
2-10	402339302	2-87	403198201	1-26	403482601
2-97B	402339403	3-12	403198301	2-8	403488601
2-99C	402339403	2-60	403199301		
2-135	402339602	2-93	403215501		

NUMERICAL INDEX

FIGURE & INDEX NUMBER	PART NUMBER	FIGURE & INDEX NUMBER	PART NUMBER	FIGURE & INDEX NUMBER	PART NUMBER
2-30 3-REF 2-82 4-5 2-76	403491801 403777502 403777502 403778201 420337101				

NUMERICAL INDEX

FIGURE & INDEX NUMBER	PART NUMBER
2-28	00002708-6
2-85	00029526-1
2-56	10025020-8
2-26	10025044-8
3-8	10037026-1
3-1	10037062-6
2-53	10039083-9
2-74	10049017-6
2-74A	10057075-3
2-83	10058118-0
2-59	10075020-7
3-4	10075109-8
2-54	10089007-8
2-55	10089021-9
2-76	10097079-7
2-74	10097088-8
2-3	10097221-5
2-4	10097222-3
2-101	10109515-6
1-6	10109825-9
1-7	10109826-7
1-4	10190046-2
2-52	10308401-8
2-118	10410198-5
2-6	42420322-2
2-5	42420324-8
1-10	43430070-3
2-111	400394301-8
2-8	401209304-5
2-44	401292309-2
2-54	402271201-4
2-70	402271301-2
2-68	402271402-8
1-REF	402336401-3
1-15	402336501-0
2-REF	402336501-0
2-40	402336702-4
3-REF	402336801-4
2-82	402336802-2
2-2	402336902-0
2-35	402337201-6
1-5	402337305-5
1-3	402337703-1
2-127	402338204-9
2-60	402338302-1

FIGURE & INDEX NUMBER	PART NUMBER
2-60A	402338401-1
2-31	402338606-0
2-51	402338702-2
2-14	402338907-7
2-16	402339006-7
2-11	402339302-1
2-97B	402339403-6
2-42	402339803-7
4-9	402340104-7
2-117	402340201-1
3-14	402341003-0
2-37	402341102-0
4-1	402365501-4
2-1	402370901-9
2-62	402383102-9
2-25	402390002-2
2-21	402390702-7
2-22	402390802-5
2-23	402390902-3
2-24	402391002-1
2-108	402537801-1
4-7	402545304-6
2-95	402550102-4
2-39	402552002-6
2-64	402553003-3
2-98	402560202-2
2-57	402573503-8
2-13A	402573701-8
2-43	402573701-8
2-94	402584501-9
2-20	402603702-2
2-19	402606601-1
2-66	402624902-1
2-48	402636803-7
1-12	403010702-5
2-15	403012302-2
2-47	403022102-4
3-2	403022501-7
1-8	403076701-8
3-9	403076801-6
2-114	403096301-3
2-106	403123501-5
2-102	403123802-7
2-97A	403123903-3

FIGURE & INDEX NUMBER	PART NUMBER
2-99A	403123903-3
2-100	403156501-5
2-110	403156902-5
2-91	403181201-1
1-14	403198201-2
2-86	403198201-2
3-12	403198301-0
2-61	403199301-9
2-29	403214401-8
4-8	403219101-9
2-112	403219201-7
4-REF	403219201-7
2-116	403225601-0
2-41	403245601-6
2-41	403245602-4
2-57	403255501-5
2-73	403257202-8
1-1	403274402-3
3-3	403281601-1
4-6	403287401-0
2-75	403370501-5
2-45B	403375201-7
2-44	403375301-5
2-45C	403376501-9
2-45	403376601-7
2-18	403391101-9
3-REF	403777501-4
2-18	403777501-4
4-5	403778201-0
2-77	420337101-8

(INTENTIONALLY LEFT BLANK)

**READER'S
COMMENT
FORM**

Please check or fill in the items; adding explanations/comments in the space provided.

Which of the following terms best describes your job?

- | | | | |
|---|--|---|--|
| <input type="checkbox"/> Field Engineer | <input type="checkbox"/> Manager | <input type="checkbox"/> Programmer | <input type="checkbox"/> Systems Analyst |
| <input type="checkbox"/> Engineer | <input type="checkbox"/> Mathematician | <input type="checkbox"/> Sales Representative | <input type="checkbox"/> Systems Engineer |
| <input type="checkbox"/> Instructor | <input type="checkbox"/> Operator | <input type="checkbox"/> Student/Trainee | <input type="checkbox"/> Other (explain below) |

How did you use this publication?

- | | | | |
|--|---|-----------------------------------|--|
| <input type="checkbox"/> Introductory text | <input type="checkbox"/> Reference manual | <input type="checkbox"/> Student/ | <input type="checkbox"/> Instructor text |
| <input type="checkbox"/> Other (explain) _____ | | | |

Did you find the material easy to read and understand? Yes No (explain below)

Did you find the material organized for convenient use? Yes No (explain below)

Specific criticisms (explain below)

Clarifications on pages _____

Additions on pages _____

Deletions of pages _____

Errors on pages _____

Explanations and other comments:

(If at all possible, mark-up copies of the problem manual pages and return those with this form.)

Note: Staples can cause problems with automated mail sorting equipment. Please use pressure sensitive or other gummed tape to seal this form. If you would like a reply, please supply your name and address on the reverse side of this form.

Thank you for your cooperation. No postage stamp necessary if mailed in the U.S.A.

YOUR COMMENTS PLEASE

Your constructive criticism can help us produce better publications in the future. This form may be used to communicate your views about this publication. Provide specific page and line references where they are appropriate.

STC shall have the nonexclusive right, at its discretion to use and distribute all submitted information, in any form, for any and all purposes, without obligation of any kind to the submitter. Your interest is appreciated.

FOLD AND TAPE

DO NOT STAPLE

FOLD



NO POSTAGE
NECESSARY
IF MAILED
IN THE
UNITED STATES

BUSINESS REPLY CARD
FIRST CLASS PERMIT NO. 2 LOUISVILLE, CO U.S.A.

POSTAGE WILL BE PAID BY ADDRESSEE

Storage Technology Corporation
2270 South 88th Street
Louisville, Colorado 80028

Attn: Tape/Disk Technical Publications M.D. 97



FOLD

DO NOT STAPLE

FOLD

If you would like a reply, please print:

Your Name: _____

Company Name: _____ Department: _____

Street Address: _____

City: _____

State: _____ Zip Code: _____