

WANGWRITER**Models:****5503, 5703****5504, 5704****5524, 5724**

PREFACE

This document is the Standard (STD) Maintenance Manual for the Wangwriter Models 5503/5703, 5504/5704, and 5524/5724. Manual organization is in accordance with the approved STD outline established at the Field/Home Office Publications meetings conducted on September 14th and 15th, 1982. The scope of this manual reflects the type of maintenance philosophy selected for this product (swap unit, printed circuit assembly, chip level or any combination thereof).

The purpose of this manual is to provide the Wang-trained Customer Engineer (CE) with instructions to operate, troubleshoot and repair the Wangwriter. Manual updating will be on a regular schedule.

Fourth Edition (August 1983)

This edition of the Wangwriter STD manual obsoletes document no. 729-0863-B. The material in this document may be used only for the purpose stated in the Preface. Updates and/or changes to this document will be published as either Product Service Notices (PSN's) or subsequent editions.

This document is the property of Wang Laboratories, Inc. All information contained herein is considered company proprietary, and its use is restricted solely for the purpose of assisting the Wang-trained CE in servicing this Wang product. Reproduction of all or any part of this document is prohibited without the prior consent of Wang Laboratories, Inc.

TABLE OF CONTENTS

CHAPTER		PAGE
1	INTRODUCTION	
	1.1 Applicable Documents	1-2
	1.2 Summary of Models	1-2
	1.3 System Specifications	1-8
2	FUNCTIONAL DESCRIPTION	
	2.1 System Timing	2-1
	2.2 CPU Operation	2-5
	2.3 System Turn-on and Power-up Diagnostics	2-7
	2.4 Memory Accessing	2-7
	2.5 Interrupt System	2-15
	2.6 Input/Output Operations	2-18
	2.6.1 Disk Communications	2-19
	2.6.2 CRT Display and Control	2-25
	2.6.3 Printing Communications	2-34
	2.6.4 Keyboard Communications	2-42
	2.6.5 Foreground Telecommunications	2-43
	2.7 Single Sheet Feeder Operation	2-50
3	OPERATION	
	3.1 Controls and Indicators	3-1
	3.2 Loading the Operating System	3-1
	3.3 Archive Diskette Insertion	3-5
	3.4 Creating a Document	3-6
	3.5 Printing a Document	3-6
	3.6 Shutting Down the System	3-8
4	INSTALLATION	
	4.1 Site Requirements/Recommendations	4-1
	4.2 Environmental Considerations	4-1
	4.3 Unpacking	4-2

TABLE OF CONTENTS (continued)

CHAPTER		PAGE
4	INSTALLATION (continued)	
	4.4 System Interconnections	4-2
	4.5 Inspection	4-2
	4.6 Initial Turn-on/Power-up Diagnostic	4-16
	4.7 Single-Sheet Feeder Installation and Checkout	4-26
	4.8 Foreground Telecommunications Installation	4-31
5	PREVENTIVE AND CORRECTIVE MAINTENANCE	
	5.1 Preventive Maintenance	5-1
	5.1.1 Cleaning and Inspection	5-1
	5.1.2 Lubrication	5-2
	5.1.3 Visual Inspection	5-2
	5.2 Corrective Maintenance	5-6
	5.2.1 Checks and Adjustments	5-6
	5.2.1.1 Printer Assembly	5-6
	5.2.1.2 Disk Drive	5-35
	5.2.1.3 Video Monitor	5-53
	5.2.1.4 Power Supply	5-55
	5.2.2 Removal and Replacement	5-57
	5.2.2.1 Side Covers	5-57
	5.2.2.2 Printer	5-58
	5.2.2.3 CPU, Printer, CRT/Mem PCA	5-59
	5.2.2.4 Disk Drive	5-61
	5.2.2.5 Print Head Assembly	5-62
	5.2.2.6 Power Supply	5-64
	5.2.2.7 CRT Cover	5-64
	5.2.2.8 Carriage	5-65
	5.2.2.9 Cord	5-66
	5.2.2.10 Photo Sensor	5-68
	5.2.2.11 Paper Feed Tray	5-68
	5.2.2.12 Platen Assembly	5-68

TABLE OF CONTENTS (continued)

CHAPTER		PAGE
5	PREVENTIVE AND CORRECTIVE MAINTENANCE (continued)	
	5.2.2.13 System Keyboard	5-68
	5.2.2.14 Card Guide	5-68
	5.2.2.15 Hammer	5-68
	5.2.2.16 Print Wheel	5-68
	5.2.2.17 CRT PCA	5-68
6	SCHEMATICS	
7	ILLUSTRATED PARTS BREAKDOWN	
8	TROUBLESHOOTING	
	8.1 System Diagnostics	8-1
	8.1.1 Main Memory Diagnostic	8-5
	8.1.2 CRT Memory Diagnostic	8-8
	8.1.3 Z80 Instruction Set	8-9
	8.1.4 CTC Diagnostic	8-9
	8.1.5 Disk	8-12
	8.1.6 Display and Keyboard Diagnostic	8-13
	8.1.7 Lamp and Status Diagnostic	8-18
	8.1.8 Printer Diagnostic	8-19
	8.1.9 VCO Adjustment	8-26
	8.1.10 FTC Board Diagnostic	8-27
	8.2 Power Distribution	8-28
	8.3 Trouble Analysis Flowcharts	8-28
	8.3.1 CRT Failure	8-29
	8.3.2 Printer Failure	8-29
	8.3.3 Print Quality Troubleshooting	8-29
	8.3.4 Single-Sheet Feeder Troubleshooting	8-48

TABLE OF CONTENTS (continued)

APPENDICES

- A MNEMONIC CODE
- B RETROFIT FOR SINGLE-SHEET FEEDER
- C INSTALLATION OF SECOND DISK DRIVE
- D MEMORY ADDRESS TABLES

LIST OF ILLUSTRATIONS

FIGURE		PAGE
2-1	System Block Diagram	2-2
2-2	Clock Output	2-4
2-3	CPU Functional Diagram	2-6
2-4	Memory Accessing	2-8
2-5	System Interrupt	2-16
2-6	Disk Communication	2-20
2-7	Screen Format	2-26
2-8	Formation of Characters 5 X 7 Matrix	2-27
2-9	CRT Control	2-30
2-10	Printer Communications	2-36
2-11	Permanent Magnet Motor	2-38
2-12	Motor Driver	2-39
2-13	Drive and Power Waveforms	2-40
2-14	Chopper Technique	2-41
2-15	Keyboard Communications	2-44
2-16	Telecommunications	2-46
3-1	Controls and Indicators	3-3
4-1	Wangwriter Unpackaging	4-3
4-2	System Cabling	4-9
4-3	Component Interconnections	4-10
4-4	CPU Board Option-Switch Settings	4-15
4-5	System-Disk Insertion	4-17
4-6	Power-Up Checkout	4-20
4-7	Power Supply Voltages	4-25
4-8	Single Sheet Feeder - Installed	4-27
4-9	Static Eliminator Installation	4-28

LIST OF ILLUSTRATIONS (continued)

FIGURE		PAGE
4-10	Typical Communications Configuration - W4-FTC-TTE Protocol	4-33
4-11	Typical Communications Configuration - W4-FTC-2236 Protocol	4-34
4-12	Typical Communications Configuration - W4-FTC-Batch Protocol	4-35
5-1	Printer Lubrication Points	5-3
5-2	Printer Adjustments	5-4
5-3	Print Wheel and Alignment Disks	5-9
5-4	Alignment Tool Using Small End	5-9
5-5	Print Wheel-to-Platen Spacing	5-9
5-6	Print Wheel-to-Platen Adjustment	5-11
5-7	Alignment Tool Using Large End	5-13
5-8	Hammer-to-Platen Check	5-13
5-9	Hammer-to-Platen Adjustment	5-14
5-10	Hammer Check and Adjustment	5-16
5-11	Print Wheel Positions	5-17
5-12	Home Position Adjustments	5-17
5-13	Print Solenoid Arm and Lamination Adj	5-19
5-14	Print Solenoid Arm and Lamination Gap	5-19
5-15	Cord Tension Check	5-21
5-16	Cord Tension Adjustment	5-22
5-17	Backlash Check and Alignment	5-22
5-18	Card Guide Check and Adjustment	5-25
5-19	Left Margin Home Position Adjustment	5-27
5-20	Ribbon Drive Spring Tension Check	5-29
5-21	Ribbon Drive Motor	5-31
5-22	Daisy Wheel Damper Check	5-32
5-23	Ribbon-Height Check and Adjustment	5-34
5-24	MPI Disk Drive PC Board Test Locations	5-39
5-25	Tandon Disk Drive PC Board Test Locations	5-40
5-26	Track Signals	5-42
5-27	Stepper Pulley/Band Assembly	5-43

LIST OF ILLUSTRATIONS (continued)

FIGURE		PAGE
5-28	Radial Alignment and Index Sensor Adjust (Tandon)	5-44
5-29	Track 00 Adjust (Tandon)	5-45
5-30	Index-to-Data Alignment Pattern	5-46
5-31	Index Sensor Mounting Screws	5-47
5-32	Track 00 Sensor Mounting Screws	5-49
5-33	Electronics Board for 12-Inch Display Monitor	5-54
5-34	Power Supply Voltage Adjustments	5-56
5-35	Keyboard & Video Cables	5-57
5-36	Right Side Cover Removal	5-57
5-37	Control Panel Removal	5-58
5-38	Flex and Sensor Cables	5-58
5-39	Removal of Mounting Screws	5-59
5-40	Board-to-Support Rod Nuts	5-59
5-41	PCA Connectors	5-60
5-42	ZIF Connector	5-60
5-43	Power and Ribbon Cables	5-61
5-44	Mounting Bracket Slots	5-61
5-45	Head and Flex Cable	5-62
5-46	Head Assembly Base Plate Mounting	5-63
5-47	Power Supply Removal	5-64
5-48	CRT Cover Removal	5-64
5-49	Carriage Rods Hold Downs	5-65
5-50	Carriage Flexible Cable	5-65
5-51	Cord Replacement	5-67
7-1	CRT Assembly	7-3
7-2	Keyboard Assembly	7-5
7-3A	Left Side Assembly - 5503	7-7
7-3B	Left Side Assembly - 5503A/5503D/5504S/5504D	7-9
7-4A	Right Side Assembly - 5503/5503A/5503D	7-11
7-4B	Right Side Assembly - 5504S/5504D	7-13
7-5A	Printer Mechanism Assembly - 5503	7-15
7-5B	Printer Mechanism Assembly - 5504	7-17
7-6	Head Assembly	7-19

LIST OF ILLUSTRATIONS (continued)

FIGURE		PAGE
7-7	Motor Mount Assembly	7-21
7-8	Daisy Damper Assembly	7-23
7-9A	Power Supply Assembly - 5503	7-25
7-9B	Power Supply Assembly - 5504	7-27
8-1	Board Location of Memory Addresses - 5503	8-6
8-2	Memory Address Chip Location - 5504	8-10
8-3	Display Attributes	8-14
8-4	Keyboard Test	8-16
8-5	Soft Character Generator Memory Test	8-17
8-6	System Power Distribution	8-30
8-7	CRT PCA +12V Test Location	8-35

LIST OF TABLES

TABLE		PAGE
4-1	Error Code Indications	4-19
4-2	Modem Interface Cables	4-32
4-3	Direct Connection Cables	4-36

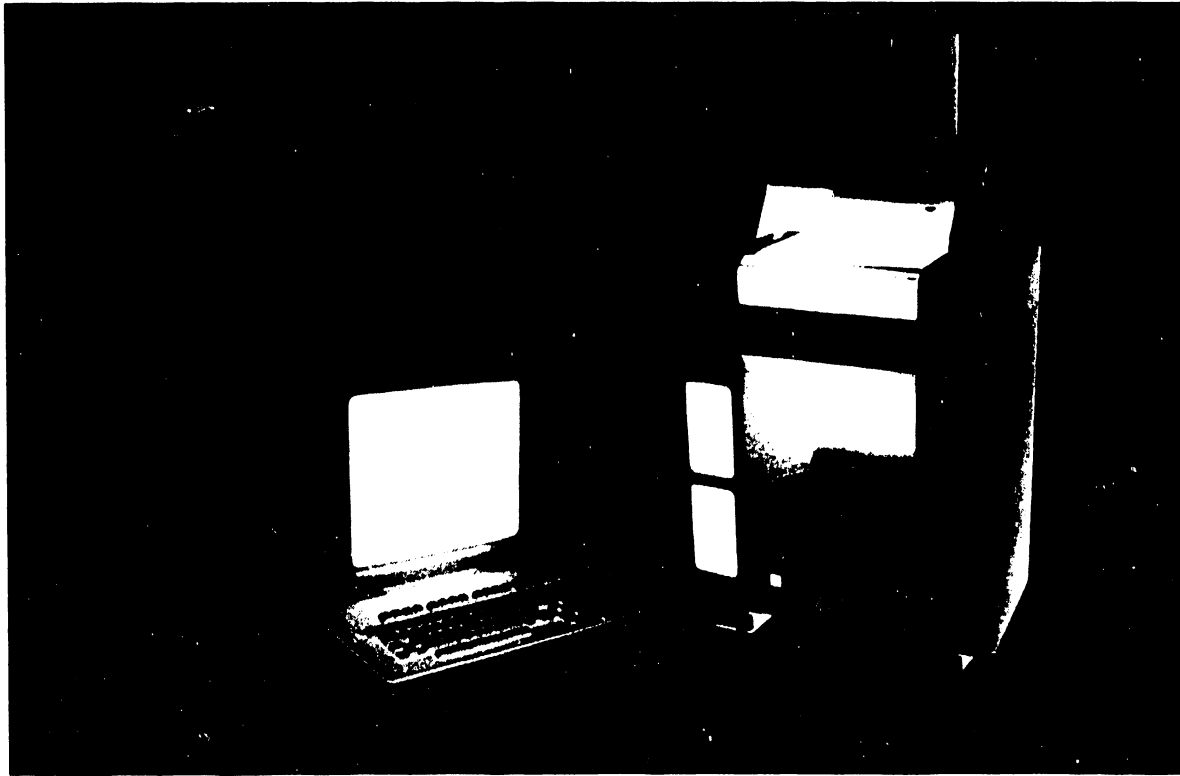

CHAPTER

1

**INTRO-
DUCTION**

CHAPTER 1

INTRODUCTION

This manual contains information for servicing the Wangwriter (Models 5503, 5504, and 5524 plus international models 5703, 5704, and 5724) in the field. Where noted, the information covers maintenance usually done at a higher level.

The Wangwriter is a self-contained (standalone) word processing system containing the components necessary for both visual text processing and document printing. In addition to word processing, the system offers optional data processing applications (all models) and telecommunications (Model 5503 excepted). The system contains three principal units:

- CRT display terminal - A 12-inch screen, and associated electronics, capable of displaying 24 lines, with 80 characters in each line. The display features horizontal scrolling which allows writing of documents with lines of up to 158 characters.
- Moveable keyboard - A typewriter-like keyboard, capacitive type, with the addition of operational keys and a cursor movement keypad. Two options, a standard keyboard and an expanded keyboard for international use, are available. The standard keyboard has a 44 character keypad; the international keyboard has 48 characters. Keycap conversion kits are available for the most-used languages.
- Printer console - A floor-standing console containing either single or dual mini-diskette drives, the printer assembly, the minidiskette drive, and the system power and electronics. The printer uses standard plastic Daisy printer wheels offering a choice of both print face and typing pitch (10, 12, and 15 characters per inch). Either six or eight lines per inch may be selected to maintain the correct vertical proportion for the desired horizontal pitch.

A paper-feeding device (Single Sheet Feeder - optional) attaches atop the printer console of those units either designed or retrofitted for its accommodation (see SUMMARY OF MODELS). The feeder is both installable and removeable by operator.

1.1 APPLICABLE DOCUMENTS

The following documents apply to various aspects, of the Wangwriter systems, beyond the scope of this manual:

Wang reprint - I.B.1.S-0:

ZILOG

Z80-PIO
Z80A-PIO
Z80-SIO
Z80-CTC
Z80A-CTC

Wang reprint #03-0002-00: ZILOG Z80A Microprocessor

Tandon Corporation - Operating and Service Manual
TM-100-1 and -2 Disk Drives

Customer Engineering Reprint for Flexible Disk Drive
MPI Model 51/52:
III.A.15M-1 - REORDER NUMBER 729-1114

Customer Engineering Reprint for Diskette Storage Drive
Tandon Model TM-100-1/2
III.A.16.M - REORDER NUMBER 729-1167

1.2 SUMMARY OF MODELS

Model 5503 designates the initial Wangwriter system configuration. Model 5504 incorporates enhancements to the earlier systems, supplanting Model 5503 (see following paragraphs for leading particulars). Model 5524 replaces Model 5504, retaining the 5504 enhancements plus providing optimum compatibility with the Wangwriter Single Sheet Feeder (Model 5504 accepts the feeder also, but requires minor modification for optimum feeder operation). A "7" appearing in a model designation (e.g., 5724) indicates that the unit is designed for international (or non English language) use. A model designation preceded by the letters, TC, indicates telecommunications capability.

1.2.1 MODEL 5504/5524 ENHANCEMENTS

Model 5504/5524 incorporates system enhancements composing significant changes from Model 5503, as follows:

- Main memory size, 5503 = 96K
5504/5524 = 128K
- 5504/5524 offers an optional foreground telecommunication board (FTC).
- 5504/5524 character font memory is entirely soft loadable; 5503 models have fixed-character PROM memory for the English language and is soft loadable for other languages.
- 5504/5524 employs split-cycle access to CRT memory to prevent flashing on the CRT display.
- 5504/5524 standard linear power supply has a new ferro-resonant transformer design. This power supply is compatible with 5503 models, but is either 50 Hz or 60 Hz model.
- The PC boards, CRT/memory, printer/driver, and CPU/disk/keyboard, contain changes to accommodate 5504/5524 performance enhancements.
- All 5504/5524 model designs enable customer installation of the Wangwriter Single Sheet Feeder; of the 5503 models, those units manufactured prior to April 1982 must be retrofitted to enable customer installation of the feeder.

1.2.2 MODELS BREAKDOWN

The following lists the principal identifying characteristics of the various Wangwriter models.

<u>5503/5703 Models</u>	<u>CEI#</u>	
5503	157*/177**-9450	- Single disk drive model not <u>field</u> upgradeable to a dual disk model. This system is, however, upgradeable to allow the use of the CP/M operating system with utilities requiring a single disk drive.

*Denotes 50-Hz models

**Denotes 60-Hz models

MODELS BREAKDOWN (continued)

<u>5503/5703 Models</u>	<u>CEI#</u>	
5703	157*/177**-9451	- Same as 5503, but with expanded keyboard for international use.
5503A	157*/177**-9450	- Single-disk model with a cabinet change that allows for field upgrade to a dual-disk system model 5503D.
5703A	157*/177**-9451	- Same as 5503A, but with expanded keyboard for international use.
5503D	157*/177**-9452	- Two-disk-drive model.
5703D	157*/177**-9453	- Same as 5503D, but with expanded keyboard for international use.

<u>5504/5704 Models</u>	<u>CEI#</u>	
5504S	157*/177**-9454	- Single-disk model.
5504D	157*/177**-9456	- Two-disk-drive model.
5704S	157*/177**-9455	- Single-disk model with an expanded keyboard for international markets.
5704D	157*/177**-9457	- Dual-disk model with an expanded keyboard for international markets.
5524S	157*/177**-9478	- Single-disk model.
5524D	157*/177**-9479	- Two-disk-drive model.

*Denotes 50-Hz models

**Denotes 60-Hz models

5524/5724 Models CEI#

5724S	157*/177**-9478	- Single-disk model with an expanded keyboard for international markets.
5724D	157*/177**-9479	- Dual-disk model with an expanded keyboard for international markets.

*Denotes 50-Hz models

**Denotes 60-Hz models

1.2.3 FIELD CONVERSION

Upgrade job (UJ) kits enable field unit conversion between models. The following summarizes particulars of the various conversions.

<u>UPGRADE JOB NO.</u>	<u>DESCRIPTION</u>
UJ-2101	From 5503 to 5503-with-CP/M modification making the 5503 electronically the same as the model 5503A: Involves installation of upgraded memory PC board (210-7775 E-Rev 6) and CPU PC board(210-7777 E-Rev 13)
UJ-2102	From 5503 to 5503D or From 5503 CP/M-modified to 5503D: Comprises changes made in UJ 2101, plus new system console 279-9000-51 which includes the second disk drive, signal cable, power cable, and left cover. Option switch 4 (PC board 210-7777) set to ON.

Model conversions (continued)

<u>UPGRADE JOB NO.</u>	<u>DESCRIPTION</u>
UJ-1163	From 5503A to 5503D: Installs second disk drive, signal and power cables, and two-disk side panel. Option switch 4 (PC board 210-7777) set to ON.
UJ-206-2103	From 5503 to 5504S - 60 Hz Replaces system console with console No. 279-9000-52 - which has PC assemblies 210-7975, 7976, and 7977, and Power Supply 279-9000-62
UJ-205-2103	From 5503 to 5504S - 50 Hz Replaces console with No. 279-9000-54, and replaces power supply with No. 279-9000-63. Replaces PC boards per UJ-206-2103.
UJ-206-2104	From 5503 (with or without CP/M) to 5504D - 60 Hz Replaces system console with console No. 279-9000-53 - additions comprise second disk drive, signal and power cables, left cover, and PC boards 210-7975, 210-7976, and 210-7977. Power supply replaced with P.S. No. 279-9000-62. Option switch 4 (7977 PC board) set to ON.
UJ-205-2104	From 5503 (with or without CP/M) to 5504D - 50 Hz Same as UJ-206-2104 except that replacement power supply is part No. 279-9000-63.

Model conversions (continued)

<u>UPGRADE JOB NO.</u>	<u>DESCRIPTION</u>
UJ-206-2105	From 5503A to 5504S - 60 Hz Replaces PC board: 210-7775 by 210-7975 210-7776 210-7976 210-7777 210-7977 and replaces the power supply with P.S. No. 279-9000-62.
UJ-205-2105	From 5503A to 5504S - 50 Hz Same as UJ-206-2105 except that replacement power supply is part No. 279-9000-63.
UJ-206-2106	From 5503A to 5504D - 60 Hz Makes PC board and power supply changes per UJ-206-2105, and installs second disk drive, signal cable, and left cover. Option switch 4 (PC board 7977) to ON.
UJ-205-2106	From 5503A to 5504D - 50 Hz Makes PC board and power supply changes per UJ-205-2105, and installs second disk drive, signal cable, and left cover. Option switch 4 (PC board 7977) to ON.
UJ-206-2107	From 5503D to 5504D - 60 Hz Same hardware installations as for UJ-206-2105. Option switch 4 (PC board 7977) to ON.
UJ-205-2107	From 5503D to 5504D - 50 Hz Same hardware installations as for UJ-205-2105. Option switch 4 (PC board 7977) to ON.

Model conversions (continued)

<u>UPGRADE JOB NO.</u>	<u>DESCRIPTION</u>
UJ-1162	From 5504S to 5504D Installs second disk drive plus signal cable and left cover. Option switch 4 (PC board 7977) to ON.

1.3 SYSTEM SPECIFICATIONS

The following comprises the principal physical and operational characteristics of the Wangwriter System.

WORKSTATION/KEYBOARD

Dimensions

Height	15.0 in (38.1 cm)
Depth	12.8 in (32.5 cm)
Width	13.5 in (34.3 cm)

Approximate Net Weight

28 lb (12.72 kg)

Display Size

12 in. diagonal (30.4 cm)

Character Size

Height	0.16 in (0.41 cm)
Width	0.09 in (0.23 cm)

Capacity

24 lines, 80 characters/line

Controls

Contrast
Brightness

Cabling

10 ft (3.0 m) - workstation to printer

Keyboard

Standard Typewriter Keys
4 Cursor Control Keys
22 Special Operational Keys
Repeat Keys: cursor keys, space bar, backspace, attribute keys

Cabling

10 ft. (3.0 m) keyboard to printer

PRINTER

Dimensions

Height 26.8 in (68.1 cm)
 Depth 12.0 in (30.5 cm)
 Width 22.0 in (55.9 cm)

Approximate Net Weight
 73 lb (33.18 kg)

Speed

20 characters per second average, bidirectional

Pitch/Line Length (11")

10 pitch -- 110 characters
 12 pitch -- 132 characters
 15 pitch -- 165 characters

Paper Specifications

Minimum Width 3.5 in (8.9 cm)
 Maximum Width 11.69 in (29.7 cm)

Paper Thickness

0.027 in. (0.069 cm) (5 copies, plus original)

Character Set

Standard characters
 Special characters plus additional characters created by overstriking

Control Panel

Indicator: Power, Change Daisy Change Ribbon, Change Paper, Indicators
 Switches: Line Feed Up, Line Feed Down, Roll Up, Roll Down,
 Select, Top of Page.

Lamps

MALFUNCTION

Print Wheels (Use plastic printwheels only)

<u>10-Pitch</u>	<u>12-Pitch</u>	<u>15-Pitch</u>
Courier	Courier	Cubic
Delegate	Elite	Letter Gothic
Narrator	Letter Gothic	
OCR A	Prestige Elite	
OCR B	Scientific Gothic	
Prestige Pica		
Symbol		

Cabling

6 to 8 ft (3.0 m) printer to power source

Power Requirements

115 or 230 VAC + 10% - 15%
50 or 60 Hz \pm 1 Hz
-300 watts

Fuses

4A S.B. @ 115 VAC
2A S.B. @ 230 VAC

Operating Environment

50 F to 90 F (10 C to 32 C)
20% to 80% relative humidity, noncondensing
(recommended 35% to 65%)

MINI FLOPPY-DISK DRIVE

Media	ANSI standard 5 1/4-inch diskette
Number of Tracks	40 per side
Track Density	48 TPI
Rotational Speed	300 rpm \pm 1 1/2%
Average Latency	100 msec
Head loading time	35 msec
Access time	5 msec, track-to-track
Head settling time	15 msec
Head life	20,000 hours
Media Life	3 x 10 ⁶ passes on single track
Recording method	FM, MFM, M ² FM
Recording density (FM)	2938/5876 bpi
Flux density	5876 fci max.
Data-transfer rate	125K/250K bits/sec.
Power-up Delay	0.5 sec
Height	3.25 inches (8.255 cm)
Width	5.75 inches (14.605 cm)
Length	7.6 inches (19.30 cm)
Weight	3.0 pounds (1.36 kg)
Power	+12 VDC \pm 5%, 0.8A (1.5A surge) 0.2V ripple +5VDC \pm 5%, 0.4A, 0.1V ripple

Typical Power Dissipation	12W Operating - 6W Standby
Operating Temperature	40°F to 115°F (4.4°C to 46.1°C)
Storage Temperature	-40°F to 160°F (-40°C to 70°C)
Operating Humidity	20% to 80% (noncondensing)
Storage Humidity	5% to 95% (noncondensing)
Operating altitude	-500 ft to 10,000 ft (-152.4m to 3,048m)
Storage altitude	-1000 ft to 50,000 ft (-304.8m to 15,240m)
Vibration and Shock (Operating)	6 to 600 Hz, 0.5g

CHAPTER

2

FUNC-

TIONAL

DESCRIP-

TION

CHAPTER 2

FUNCTIONAL DESCRIPTION

This chapter describes the component actions supporting system operations. Subfunctions thus described are:

- System Timing
- CPU Operation
- System Turn-on and Power-up Diagnostics
- Memory Accessing
- System Interrupts
- Input/Output Operations
- Single Sheet Feeder Operation

Printed circuit boards house the electronic elements of the principal functional groups (see Figure 2-1). A data/address bus, common to the CPU, memory, and input/output control devices, provides the communications path between the principal groups. Peripheral devices connect to their associated I/O controls via cabling external to the respective boards.

The Z80A CPU controls the system, as directed by the program entered into the system random access memory (RAM) at each system activation. In accordance with the program, the CPU monitors the status of all input ports, and sends updated information to all output ports. The CPU accomplishes these operations via the three main busses: address, data, and control. All the input/output control devices connect to the common bidirectional three state data bus.

2.1 SYSTEM TIMING (see Figure 2-2)

A system clock comprising a 16-Mhz crystal oscillator and associated circuitry provides three clock outputs:

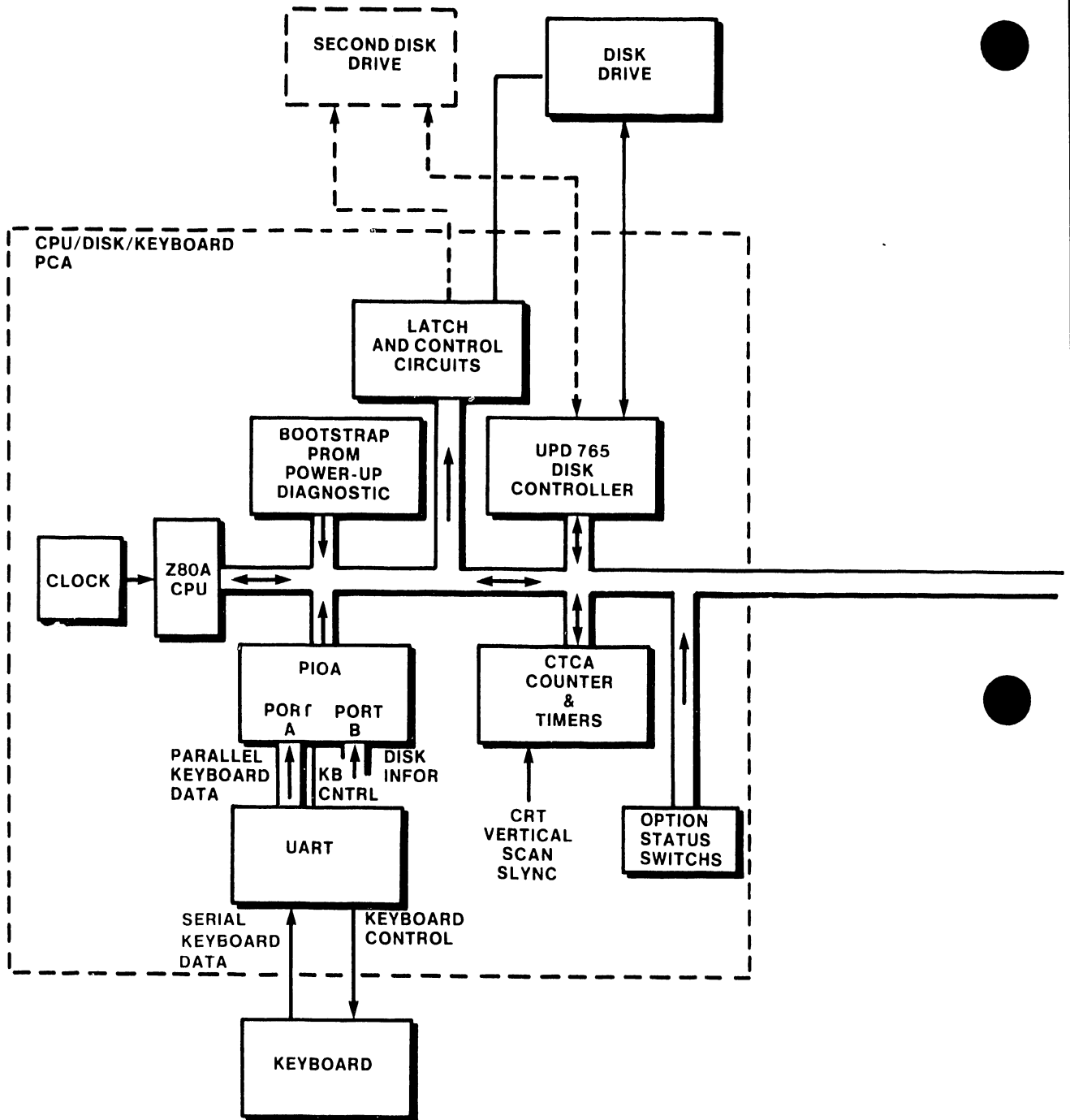

FIGURE 2-1 SYSTEM BLOCK DIAGRAM (1 OF 2)

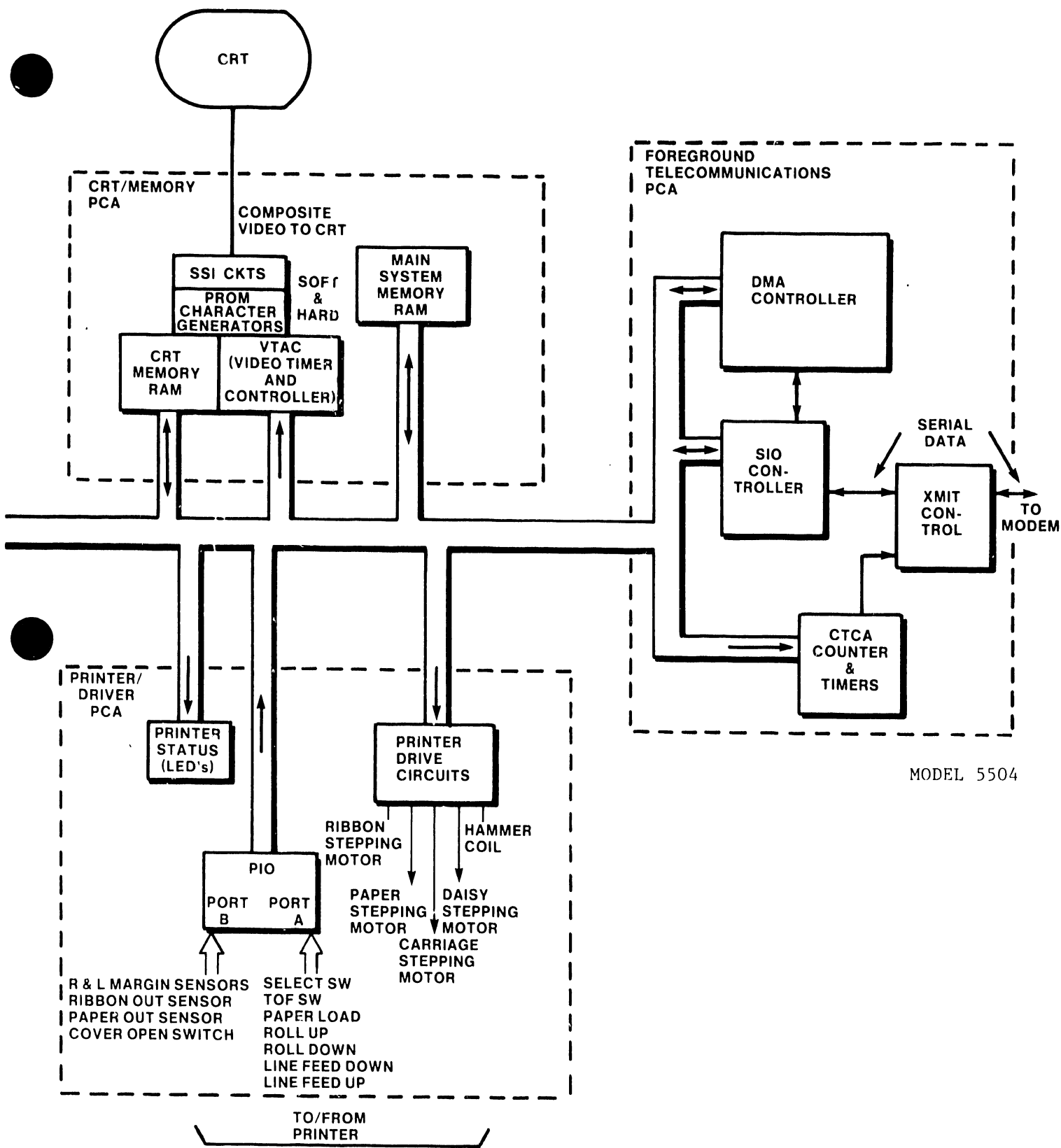

FIGURE 2-1 SYSTEM BLOCK DIAGRAM (2 OF 2)

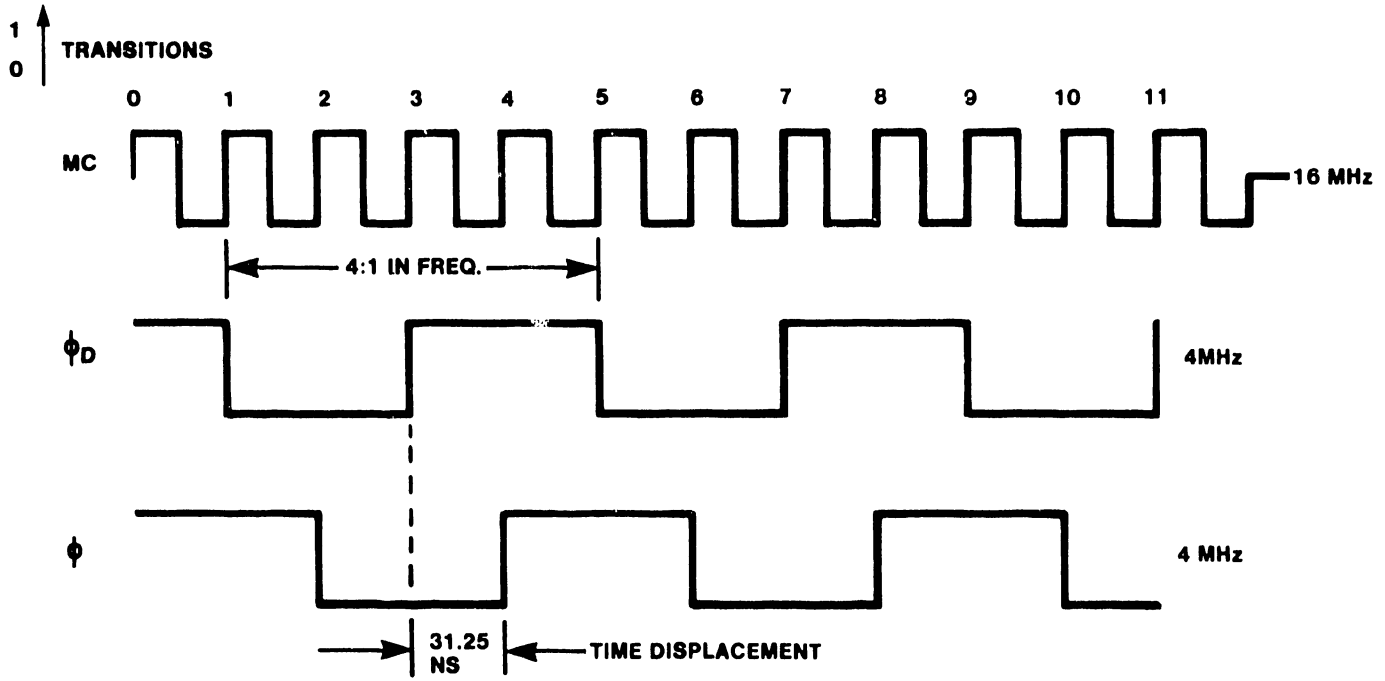

FIGURE 2-2 CLOCK OUTPUT

Master Clock (MC) = 16mHz

Φ = 4mHz

Φ D = 4mHz

There is a 90-degree displacement (31.25 nanoseconds) between Φ and Φ D.

2.2 CPU OPERATION (Figure 2-3)

The Z80A-CPU microprocessor chip, and the system software in the RAM memory, are essentially a complete CPU and operating system for the Wangwriter. The Z80A-CPU has three busses: an 8-bit bidirectional data bus for data transfer, a 16-bit address bus for addressing memory locations and I/O ports, and a 10-bit bus for system control, CPU control and bus control. The Z80A-CPU controls all functions of the Wangwriter system by stepping through a precise set of basic operations at high speed. These basic operations are: memory read and write, I/O device read and write, and interrupt acknowledge. Through the use of specific addresses, control signals, and decoder outputs, the CPU addresses and enables various memory locations and I/O ports.

The Z80A CPU obtains its operating instructions (program) by addressing the RAM memory on the CRT/MEM PCA. The system disk loads the memory each time the disk is inserted and power turned on. As the Z80A-CPU processes each instruction, it reads or writes data to and from memory and I/O devices. The Z80A-CPU communicates with all system devices (printer, floppy-disk, display unit and keyboard) to complete programmed instructions. The system program determines the sequence of communication.

The Z80A-Counter Timer Circuit (CTCA) is a programmable chip with four independent channels that provide counting and timing functions for Z80A-CPU microprocessor. The CTCA also generates an interrupt vector for each separate channel, for automatic vectoring to an interrupt service routine.

In the system, channel 2 of the CTCA is used as a general system real-time clock. In the counter mode, the channel counts vertical sync pulses (16.7ms) from the CRT timing circuit. The VTAC in the CRT circuitry must be initialized before the vertical sync period is accurate.

Channel 0, 1, and 3 of the CTCA are used in timer mode for timing printer stepper motors phase changes.

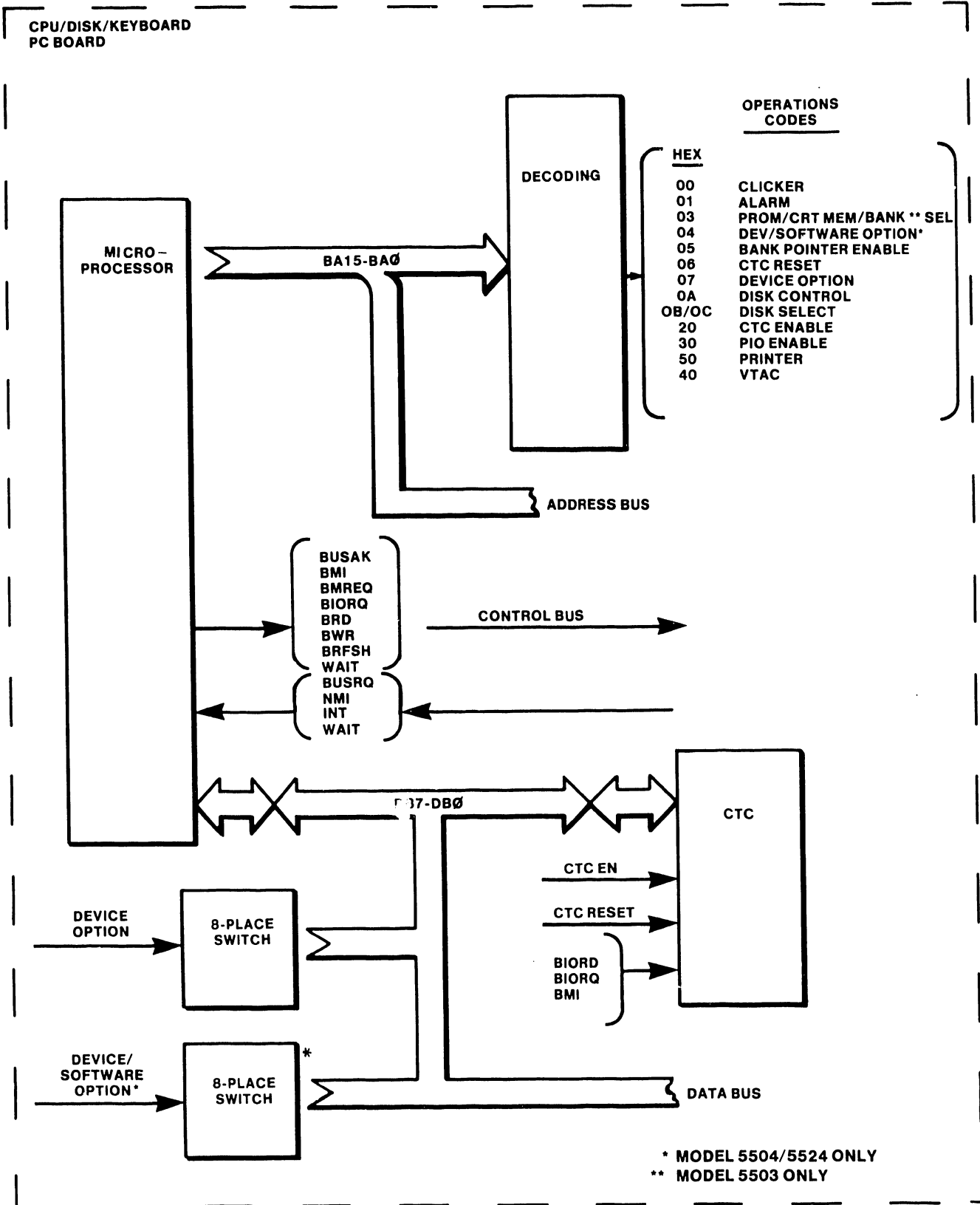

FIGURE 2-3 CPU FUNCTIONAL DIAGRAM

2.3 SYSTEM TURN-ON AND POWER-UP DIAGNOSTICS

Each turn-on of the system triggers a sequence of events to prepare the electronic components for operation (initializing) and to determine system condition (power-up diagnostics). The power-on sequence precedes, and is requisite to, the loading of the operating system.

The turning on of the power switch generates a pulse, power on reset (POR), which resets system circuits. The power-up sequence thus places the system in a known state before operation can commence.. Prior to system clock start, POR:

- Initializes VTAC
- Initializes CTC channel 2
- Disables CTC reset (Control Register D3 = 1)
- Enables CPU interrupts
- Initializes DMA (FTC board - System 5504 and 5524 Models only)
- Resets CTC (FTC board - System 5504 and 5524 Models only)

As the CPU cycles through addresses 0000 to C000, it reads NO-OP commands to permit signal settling. During this time, the data bus, DB7 - DB0, is grounded.

The PROM Select Latch (PSL) signal goes active at address C000 and starts the power-up diagnostic and bootstrap PROM. During this routine, the power-up diagnostic checks the system's major components and displays error codes for any faults. A 7-segment LED at the rear of the printer console displays the error codes.

Once this routine runs without error, the PROM bootstrap loads the operating system into the RAM from the system disk. From this point on, the CPU with instructions from the operating system controls all system functions.

2.4 MEMORY ACCESSING (Figure 2-4)

The system random access memory (RAM) stores the operating program, and serves as a buffer memory for the CRT memory, the floppy disk, and the keyboard.

The Model 5503 RAM comprises six rows of eight 16K-bit chips. Each row thus stores 16k bytes of data; total RAM memory capacity therefore equals 96K bytes.

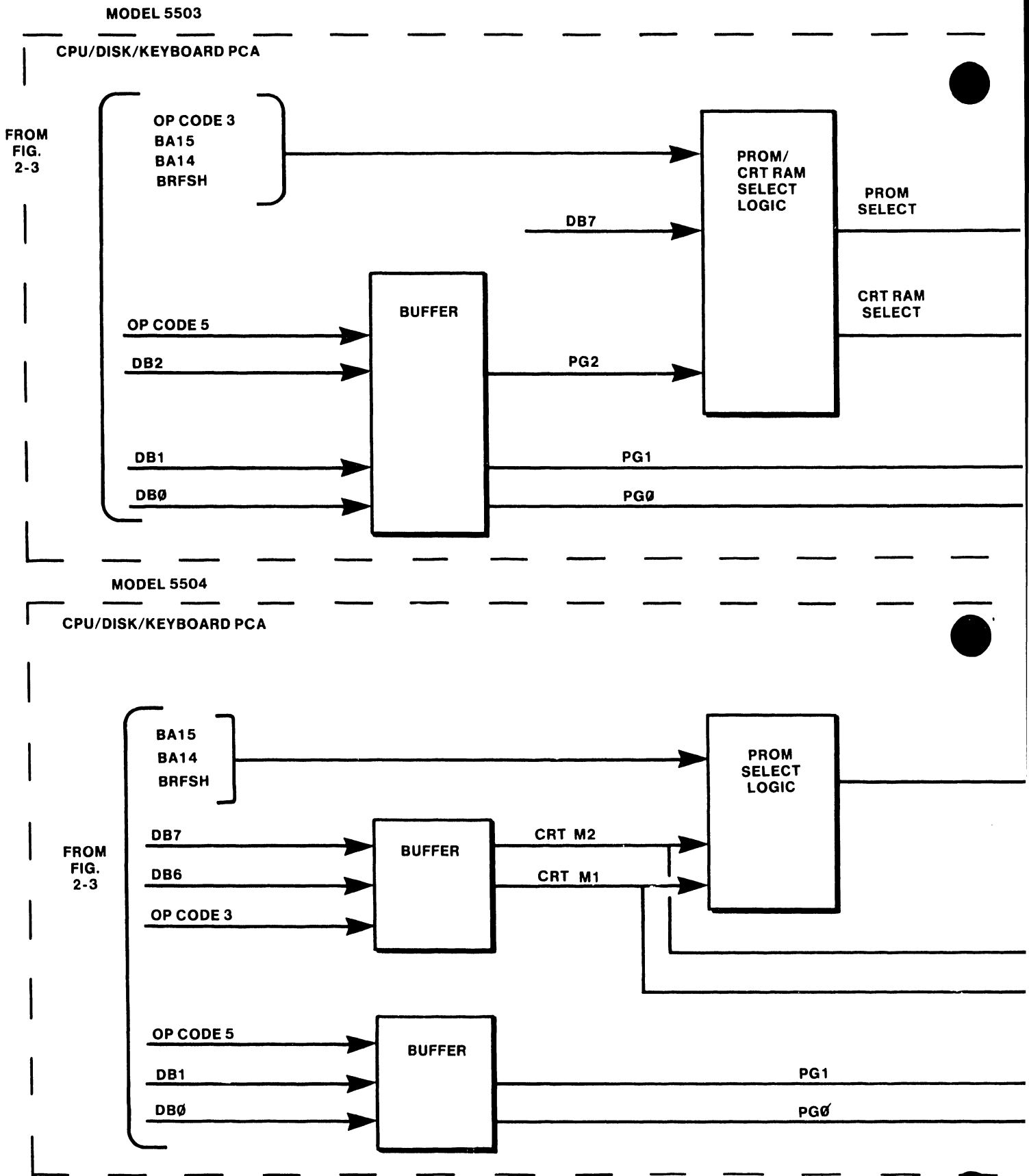

FIGURE 2-4 MEMORY ACCESSING (1 OF 6)

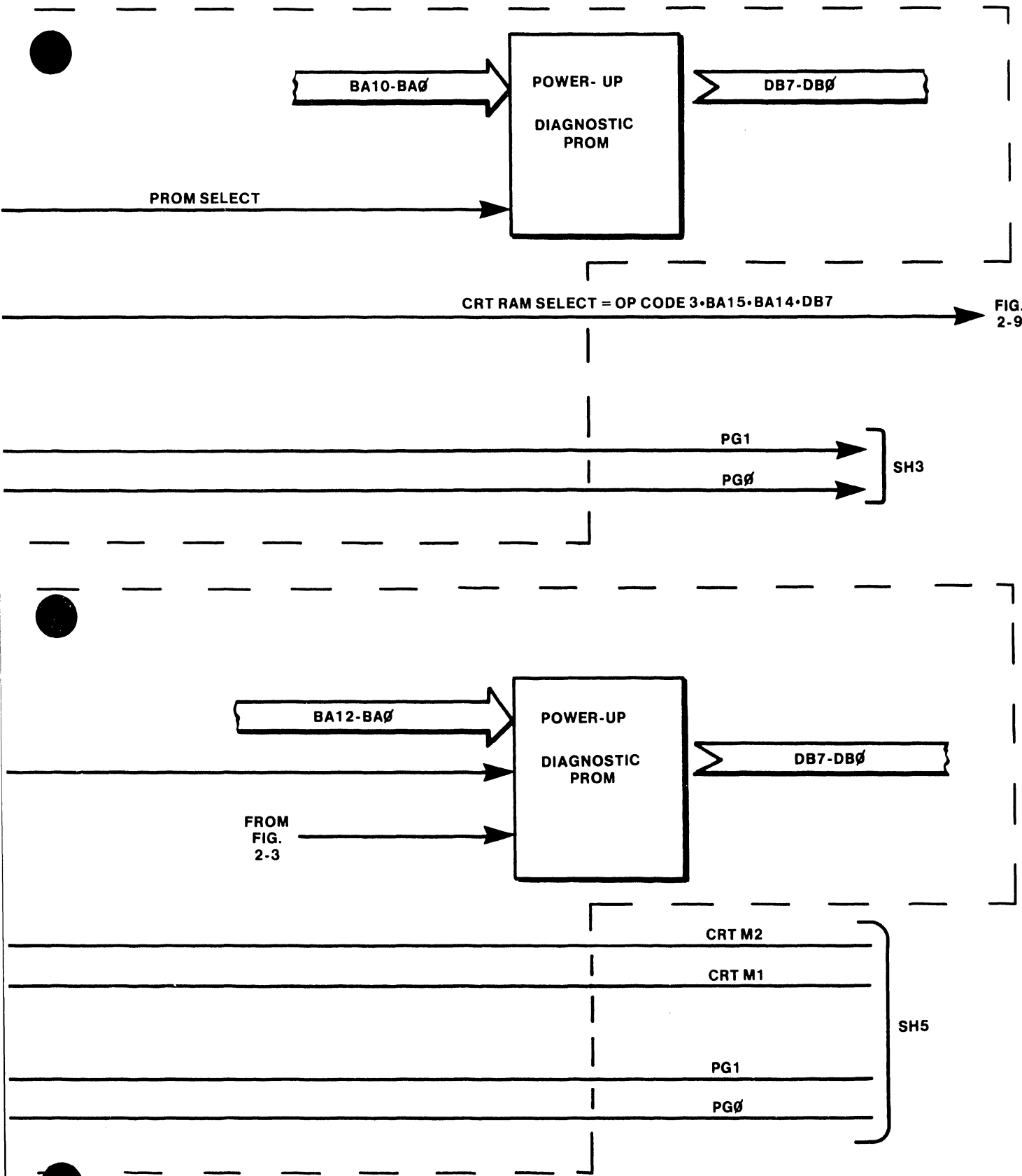

FIGURE 2-4 MEMORY ACCESSING (2 OF 6)

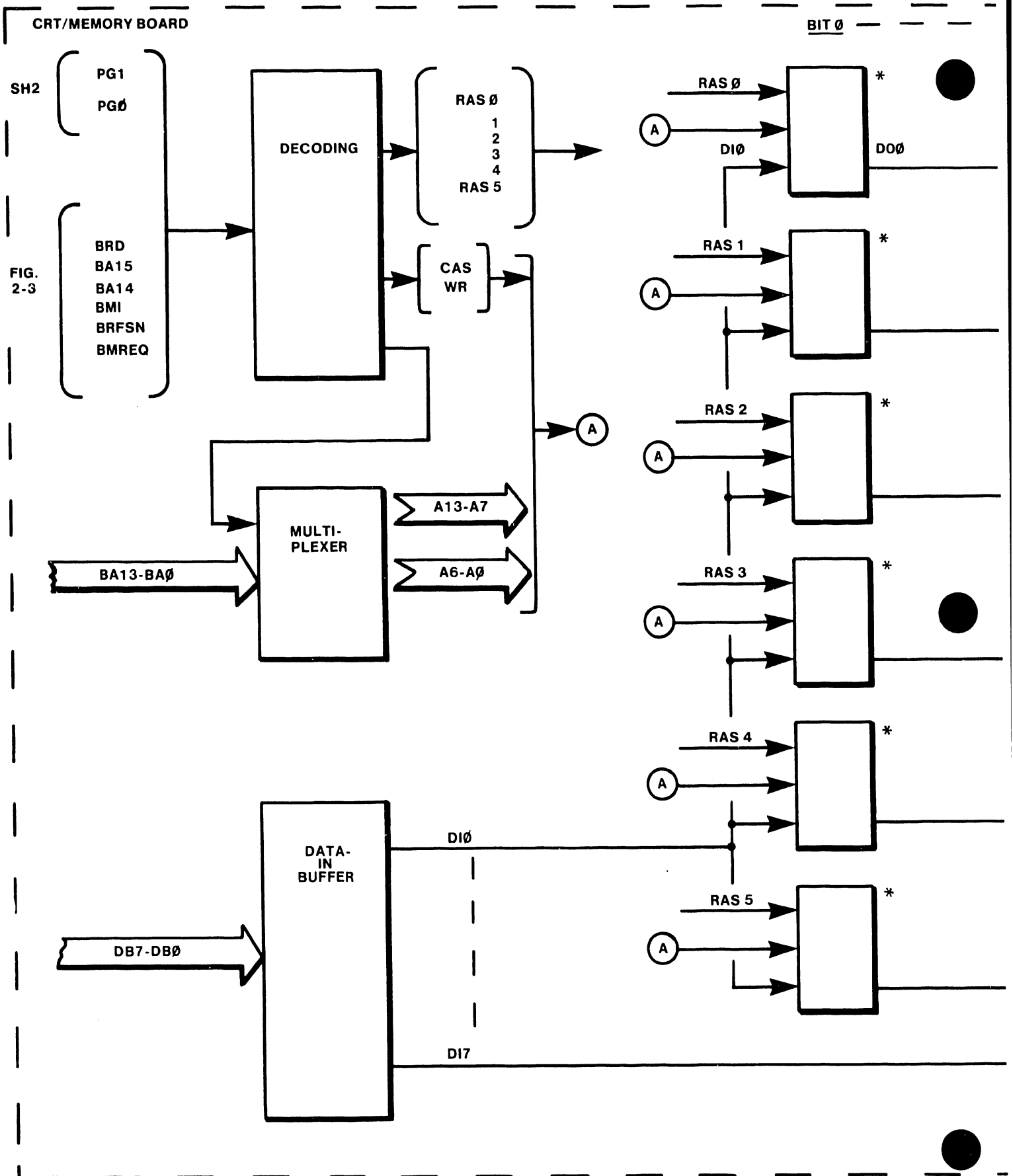

FIGURE 2-4 MEMORY ACCESSING (3 OF 6)

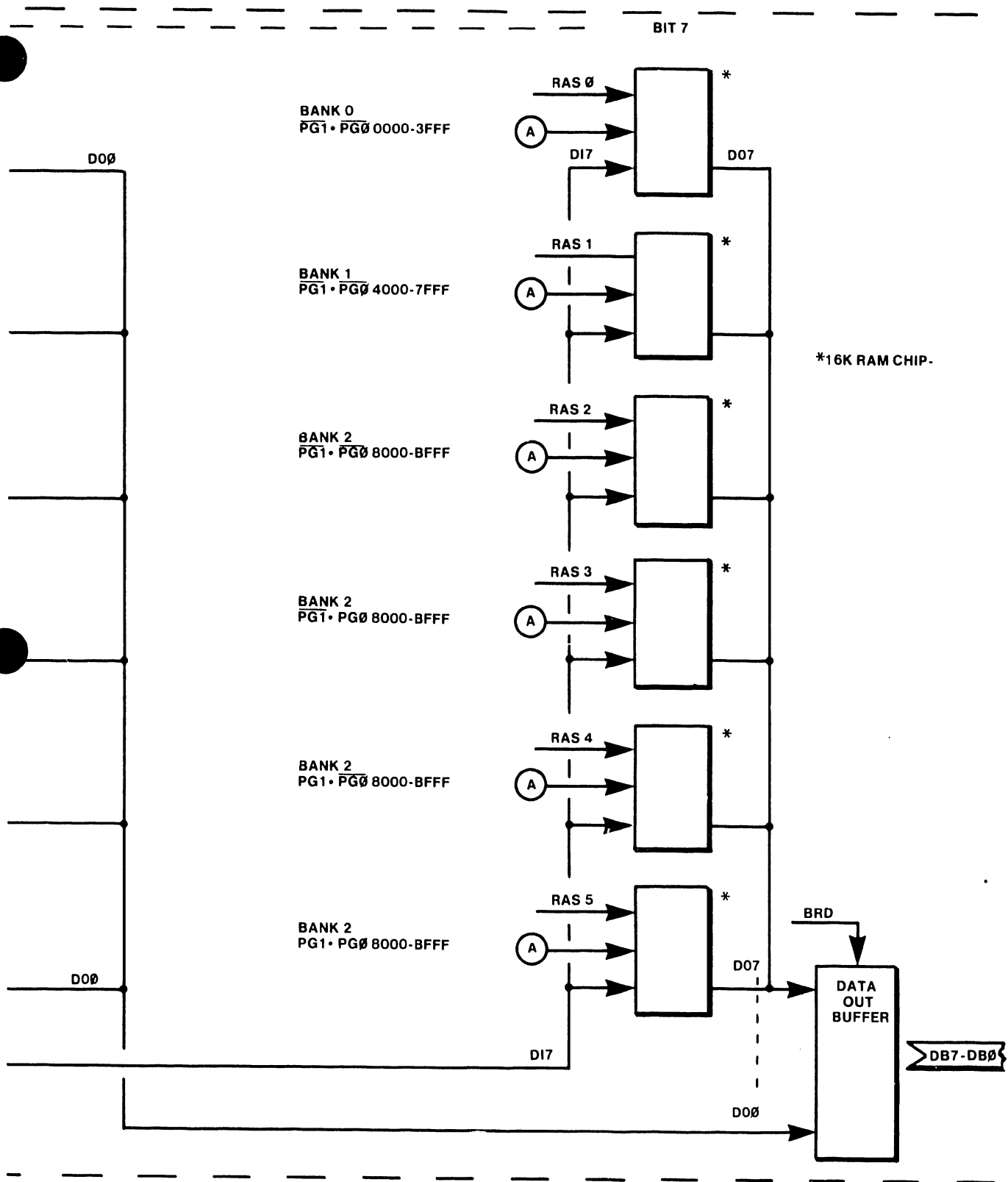

FIGURE 2-4 MEMORY ACCESSING (4 OF 6)

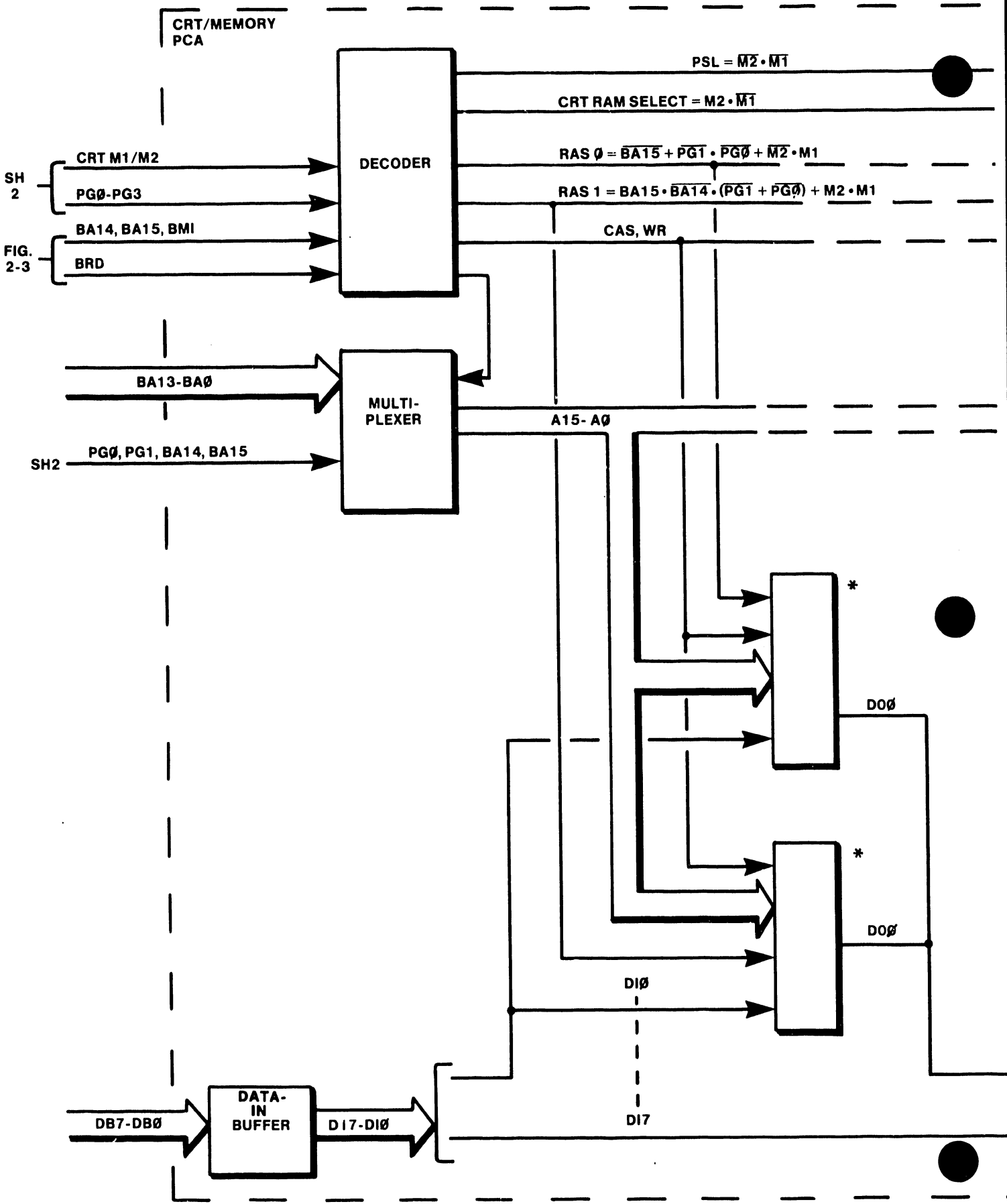

FIGURE 2-4 MEMORY ACCESSING (5 OF 6)

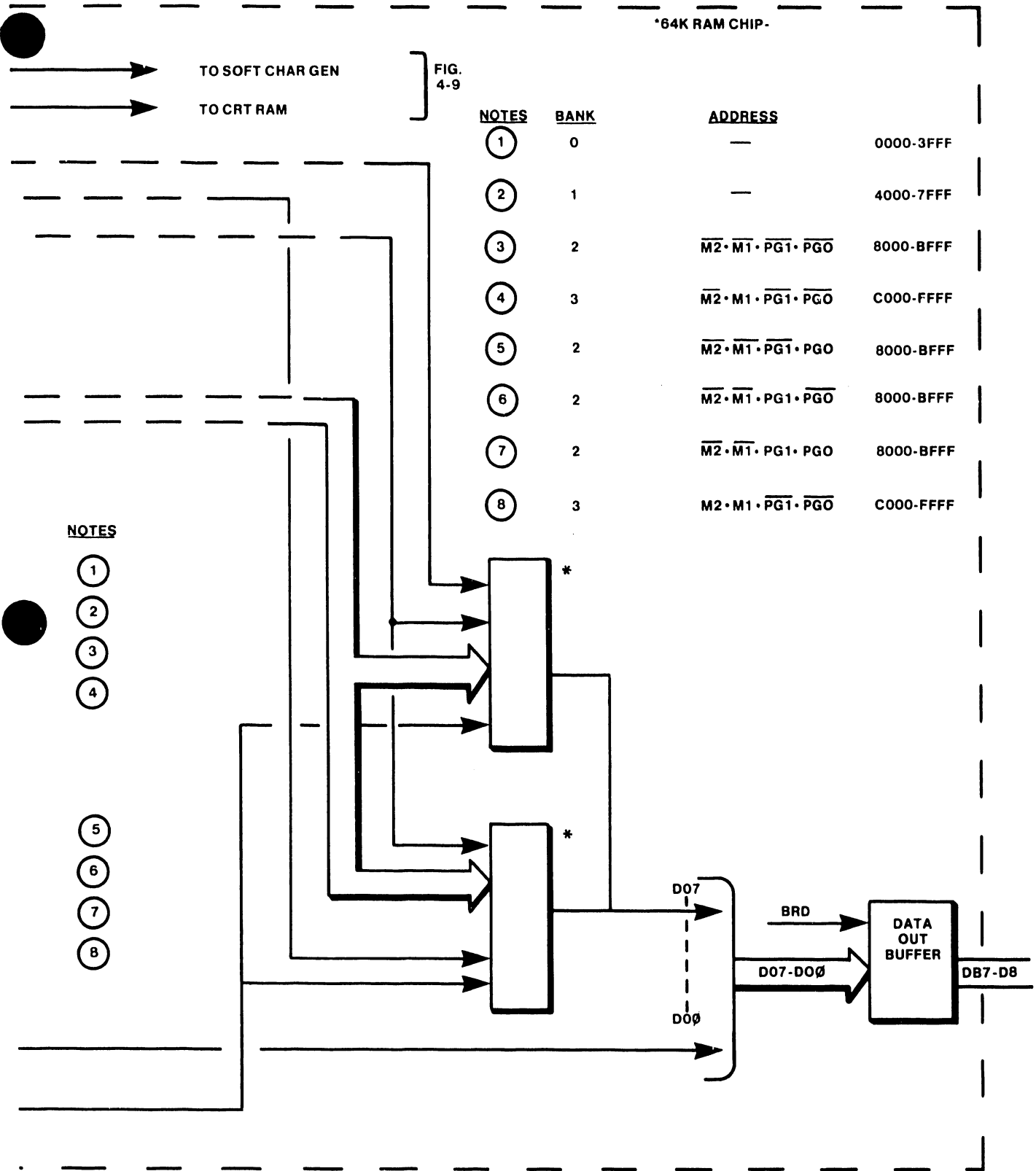

FIGURE 2-4 MEMORY ACCESSING (6 OF 6)

The Model 5504 RAM comprises two rows of eight 64K-bit chips. Each row thus stores 64K bytes of data; total RAM memory capacity therefore equals 128K bytes.

2.4.1 MEMORY ADDRESSING

Address bus BA13 through BA0 selects the memory location to be accessed. A row address strobe (RAS) and column address strobe (CAS) respectively multiplex the high-order and low-order address bits to select the given memory location. The combined 14 address bits can select up to 2^{14} (16K) locations.

Inasmuch as an addressing capability of 16K is not sufficient for the addressing of memories containing 96K/128K locations, the system uses data bits in conjunction with the address bits to expand the addressing capability. The use of data bits as additional high-order address bits enable the application of a given address (BA13-BA0) to several areas within the memory. The additional bits thus extend the addressing capability to 2^{16} (Model 5503) and 2^{18} (Model 5504).

For addressing purposes, the memory divides into "banks" (not synonymous with the actual physical rows of memory chips). A given 16K address range defines the given bank (e.g., from 0000 to 3FFF defines bank 0). However, the given bank may contain more than 16K locations (e.g., bank 2 encompasses 48K locations); the extra high-order bits, therefore, are necessary to determine which location within the bank a given address configuration specifies.

Op code 5 latches data bits 1 and 0 into a buffer to derive the extra high order bits Page (PG) 1 and 0 respectively. Op code 3 (5504 only) latches data bits 7 and 6 to derive the extra high-order bits CRT M2 and CRT M1 (used to switch a given address in bank 3 between RAM, CRT memory, and the power-up PROM).

2.4.2 MEMORY READ/WRITE

The buffered-read signal (BRD) selects between read and write modes. When BRD goes active, the addressed RAM location, when strobed by CAS, places data on the data-out (DO) lines 7 through 0. The data-out buffer places the data on the system data bus to be read by the CPU.

The strobing of a RAM address with BRD not active writes data from the CPU into memory.

2.4.3 MEMORY REFRESH

The system has a dynamic memory which must be refreshed within each 2-millisecond time interval. The CPU therefore initiates a "refresh" cycle (buffered refresh, BRFSH) for every memory cycle. The refresh cycle is identical to a memory-read cycle except that the column address strobe (CAS) is inhibited; the row address strobe (RAS) only is generated. At RAS time, each location on the selected row undergoes a read/refresh action internal to the chip (the same as in a normal memory read); however, since there is no CAS, no data is selected for output to the data bus.

At each refresh-cycle initiation, the CPU memory-control register places an address on the address bus; BRFSH, in conjunction with memory request (MREQ), bypasses RAS gating to generate a strobe to all chips. The given refresh cycle thus refreshes data at every location on the given row address.

The memory-control register increments the refresh address each cycle; therefore, each row (all locations) is refreshed once every 128 cycles (Model 5503) or once every 256 cycles (Model 5504).

2.5 INTERRUPT SYSTEM (Figure 2-5)

An interrupt allows peripheral devices to suspend CPU operations in an orderly manner to request a peripheral service routine. The service routine is either an exchange of data or an exchange of status and control information between the CPU and the peripheral. Once the service routine is completed, the Z80A-CPU returns to the operation from which it was interrupted.

The Wangwriter system uses a software maskable interrupt with an assigned priority structure. In systems without the FTC option, there are but three chips in the system that interrupt the CPU. In systems with FTC option (5504 only), two additional chips interrupt the CPU. The interrupting components, in order of priority, are:

- CTCA,
- PIOA
- PIO (printer)
- SIO (FTC board)
- CTC (FTC board)

The purpose of a generated interrupt by one of the three chips is to force the CPU to service a peripheral immediately. For instance, immediate service prevents disk overwriting, or provides timely print head/horizontal stepping motor movement.

According to the Z80A-CPU interrupt protocol, lower priority devices such as PIOA and PIO (printer) may not interrupt the higher priority CTCA. However, the high priority CTCA may interrupt the servicing of the lower priority devices.

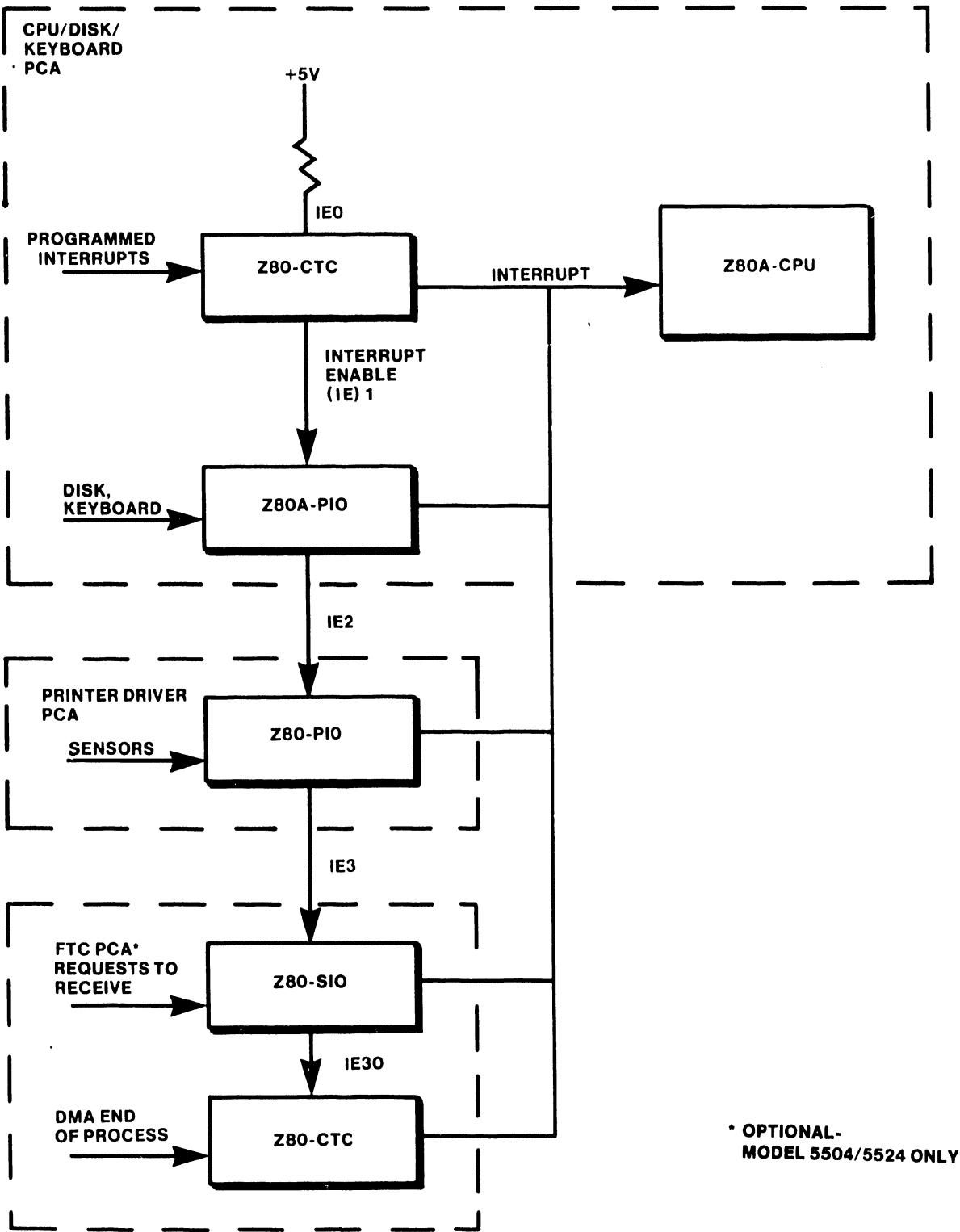

* OPTIONAL-
MODEL 5504/5524 ONLY

FIGURE 2-5 SYSTEM INTERRUPT

2.5.1 CTC INTERRUPTS

Once an interrupt is requested, the CTCA's interrupt control logic determines the priority of the requestor. The CTCA then places an 8-bit interrupt vector (memory address) on the system data bus. The high-order 5 bits of this vector have been written to the CTCA earlier as part of the CTC initial programming process. The next two bits are written by the CTCA's interrupt control logic as a binary code corresponding to the highest-priority channel requesting an interrupt. The last bit of the vector is always zero. See the chart following.

INTERRUPT VECTOR

D7	D6	D5	D4	D3	D2	D1	D0	
V7	V7	V5	V4	V3	X	X	0	
					0	0	0	Channel 0
					0	1	0	Channel 1
					1	0	0	Channel 2
					1	1	0	Channel 3

This interrupt vector is a pointer to a location in memory where the address of the interrupt service routine is stored in a table. The vector represents the least significant 8-bits; the CPU reads the contents of the I register for the most significant eight bits of the 16-bit pointer.

Z80A-CPU system conventions fix all addresses in the interrupt service routine table with their low-order byte in an even location in memory, and their high-order byte in the next highest location in memory, which will always be odd. This means that the least significant byte of any interrupt vector will always be even; therefore, the least significant bit is always zero.

The RETI instruction (Return from Interrupt) is always the last instruction in the service routine. The CTCA monitors the system data bus and decodes this instruction when it occurs. Thus, the CTCA interrupt control logic recognizes the end of service without any further communication from the CPU.

2.5.2 CPU PIOA

The CPU PIOA has the second priority position. Within a PIOA, Port A interrupts have higher priority than those on Port B. In the byte input, byte output or bidirectional modes, an interrupt is generated whenever a new byte transfer is requested by a peripheral. In the bit control mode, an interrupt is generated when the peripheral status matches a programmed value.

In the PIOA chip ports A and B have independent interrupt vectors. Vectoring is accomplished here similarly to that performed by the CTCA.

2.5.3 PRINTER PIO

The printer PIO has the lowest priority excepting systems using foreground telecommunications (Model 5504/5524 only). Function is identical to that of the PIO on the CPU board.

2.5.4 FTC BOARD SIO

When used in the interrupt mode, rather than direct-memory-access mode, the SIO generates interrupts to allow the processor to send or receive data.

2.5.5 FTC BOARD CTC

The FTC board CTC chip functions identically to the CPU board CTC. Channels 1 through 3 of the CTC generate interrupts associated with end-of-process notifications from the DMA. Each channel generates a vectored output; the vector addresses a given memory location to initiate the appropriate routine to service the given interrupt.

2.6 INPUT/OUTPUT OPERATIONS

The system inputs/outputs data:

- to/from floppy disk
- to CRT display
- to printer
- to/from telecommunications line (5504/5524 Models only)

2.6.1 DISK COMMUNICATIONS (Figure 2-6)

The 5503 system uses a flexible disk drive, (either MPI Model 52 or Tandon TM-100), to store documents and load the operating system into RAM memory on the CRT/MEM PCA. Communications are between the floppy disk and the Z80A-CPU microprocessor via the Floppy Disk Controller (FDC). Unformatted data capacity, double density, using MFM recording, is:

- 6.25K bytes per track
- 437K bytes per diskette

The CPU controls the self-contained disk drive. The drive consists of a media-rotating system, a head-load and positioning system, and a write/erase and read system. Opening the drive door allows the diskette to be inserted. When the diskette is inserted, internal guides position the diskette correctly except for the in/out position. Closing the door activates the cone/clutch system which centers the media (diskette) and clamps it to the spindle hub.

The spindle hub rotates at a constant speed of 300 rpm by means of a dc motor/tachometer and a reference in a closed-loop system. Pressure of the diskette against a platen referenced to the head and the spindle hub controls the head-to-media relationship; a pressure head is loaded against the diskette on the opposite side of the head with a force of approximately 17 grams. A four-phase, direct-drive, stepper motor/band positions the recording heads over the correct track. A one-step movement causes a one-track movement.

Band positioning enables very high step rates. When a write protected diskette is inserted, the write protect sensor disables the write/erase circuits in the drive. A write mode records a 0.013 inches (nominal) data track; a tunnel erase follows, trimming the track down to 0.012 inches (nominal). Data recovery electronics include a low-frequency amplifier, a differentiator, a cross-over detector, a digital filter, and a final pulse generator. A data decoder separates clock and data pulses on the I/O connector.

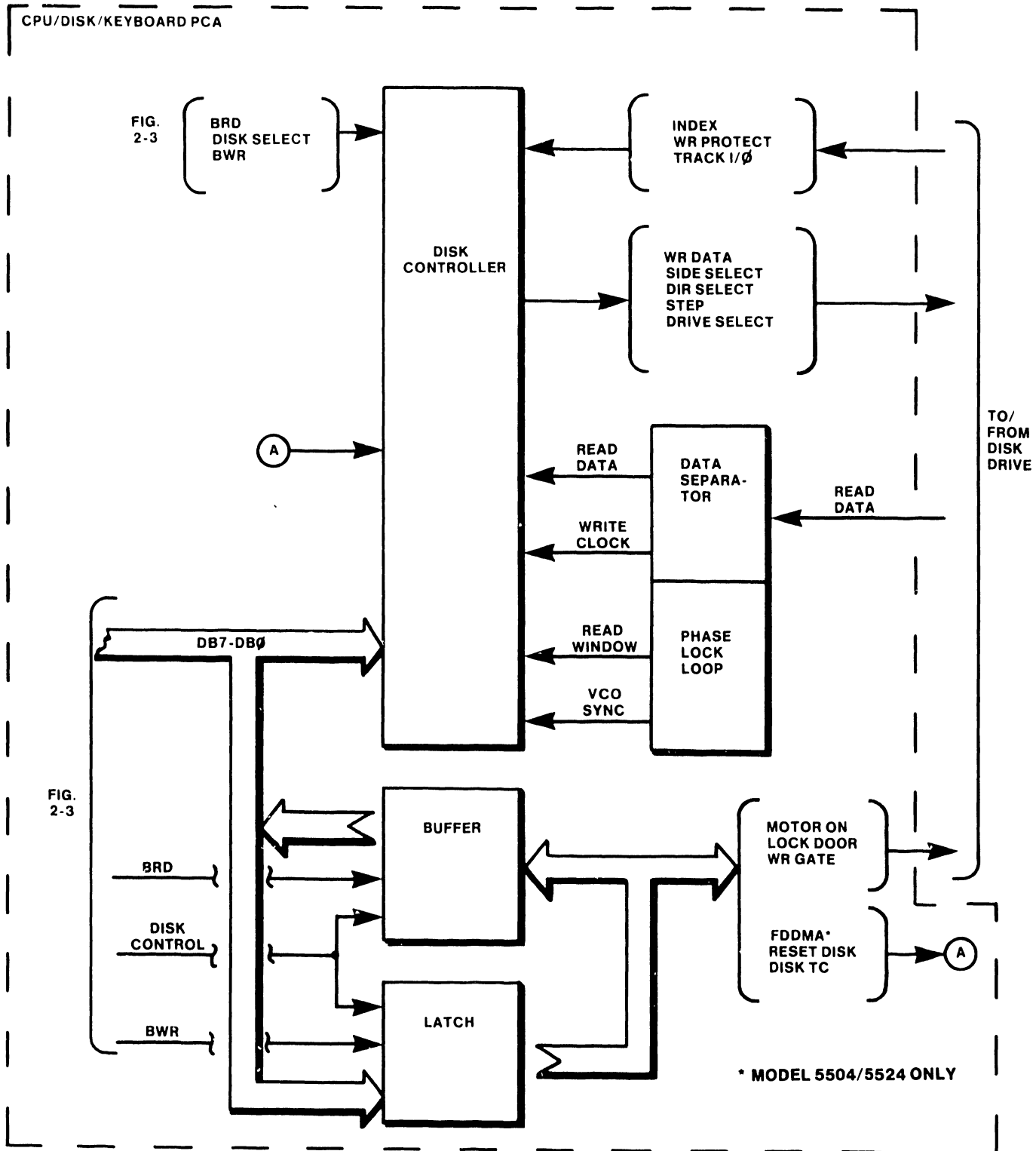

FIGURE 2-6 DISK COMMUNICATION

A uPD765 Floppy Disk Controller (FDC) interfaces the CPU to the floppy disk. The chip is capable of performing 15 commands. A multi-byte transfer from the CPU initiates each command; the result after execution of the command may also be a multi-byte transfer back to the CPU. Each command as consists of three phases:

- Command Phase: The FDC receives all information required to perform a given operation from the CPU.
- Execution Phase: The FDC performs the operation as instructed.
- Result Phase: After completion of the operation, status and other housekeeping information go to the CPU.

The CPU reads the status register of uPD765 during the command or result phases. The CPU reads this status before each byte is written into or read from the FDC data register. Bits D6 and D7 in the status register must be in a 0 and 1 state, respectively, before a byte of the command word is written into the uPD765. During the result phase, both D6 and D7 must equal 1 before the CPU reads a byte from the data register. However, the CPU does not have to read the status register during the execution phases.

The uPD765 is in the NON-DMA mode. As the uPD765 reads each data byte from the floppy disk drive, it generates an interrupt signal for the CPU. When the CPU sends a read signal, the interrupt resets and the FDC puts the data onto the data bus.

The bytes of data, sent to the uPD765 to form the command phase, must occur in a prescribed order: The command code must be sent first, then the other bytes in sequence.

After the last byte of data in the command phase is sent to the uPD765, the execution phase starts automatically. In like fashion, when the last byte of data is read out in the result phase, the command is automatically ended and the uPD765 is ready for a new command. A command may be truncated (prematurely ended) by simply sending a Terminal Count signal (TC=1). This is a convenient means of ensuring that the CPU may always get the uPD765's attention even if the disk system hangs up in an abnormal manner.

A set of nine bytes puts the FDC into the read mode. After the read data command is complete, the FDC loads the head (if it is in the unloaded state), waits the specified head settling time, and begins reading ID address marks and ID fields. When the current sector number ("R") stored in the ID register equals the sector number read off the diskette, the FDC outputs data (from the data field) byte-to-byte to the CPU via the data bus.

When the current sector is read, the sector number increments by one, and the data from the next sector is read and output on the data bus. The read data command may be terminated by the receipt of a terminal count signal. At this signal, the FDC stops outputting data to the CPU, but continues to read data from the current sector for a cyclic redundancy count (CRC) check; at the end of the sector, the FDC terminates the read command.

A set of nine bytes puts the FDC into the write-data mode. After execution of the write data command, the FDC loads the head (should the head be in the unloaded state), waits the specified head settling time, and begins reading ID fields. When the current sector number, stored in the ID register equals the sector number read off the diskette, the FDC takes data from the CPU byte-by-byte via the data bus, for output to the floppy disk drive.

After writing data into the current sector, the FDC increments the sector number stored in the ID register, and writes into the next data field. The FDC continues this operation until the terminal count signal. Should the FDC receive a terminal-count signal during writing of a data field, the FDC fills the remainder of the data field with zeroes.

In the write modes, data transfers between the CPU and FDC, via the data bus, must occur every 15 μ s in the existing MFM mode.

In Seek, the read/write head in the drive moves from cylinder to cylinder under control of the seek command. The FDC compares the present cylinder number (the current head position) with each new cylinder number. If there is a difference, the head steps in accordance with directional pulses in or out from the spindle.

If the drive is in a NOT READY state at the beginning of the command execution phase or during the seek operation, the FDC sets a flag in the status register and the command is terminated.

Before the floppy-disk controller (FDC, uPD765) reads or writes the disk drive, the disk-drive motor(s) must be turned on by MONO and/or MON1 (see Figure 2-14). Control signal BWR and decoded instruction signal DK CNTRL enable the data latch which latches the data on the bus and outputs the data plus MONO and/or MON1. The Z80A-CPU can also check the status of the disk drive by turning on the data bus buffer via DK CNTRL and BRD signals and reading the buffer's outputs.

Once there is information in the drive and its motor is running, the drive is ready to communicate with the FDC. Because RDY is tied to a high level voltage, the FDC sees the disk drive as being ready at all times.

There are four drive signals to the FDC: INDEX, TRACK ZERO, WRITE PROTECT and READ DATA (RDD).

INDEX pulses occur once every revolution of the disk (1 revolution equals 200ms) and is active about 4.5ms.

TRACK ZERO signal indicates that the drive's R/W heads are at track zero (the outside track, farthest from spindle).

WRITE PROTECT signal indicates whether a write protected diskette is installed and, if so, inhibits writing to the diskette.

READ DATA consists of MFM encoded data from the disk; sent to data separator/phase-lock loop circuits where a data window and data stream are generated before going to the FDC chip.

The input signals to the drive from the uPD765 are as follows:

The DRIVE SELECT (buffer output) signal enables a particular drive's input/output lines and loads the R/W heads. The SIDE SELECT signal indicates which R/W head is selected.

When DIRECTION SELECT is made low or high, the R/W heads step toward the spindle or away from the spindle respectively.

The STEP signal moves the R/W heads one track for each pulse.

Both DIRECTION and STEP are controlled through the RW/SEEK signal via L21. When the signal is high, the FDC is in the seek mode; when the RW/SEEK signal is low, the signals TRACK ZERO and WRITE PROTECT are enabled to the FDC.

WRITE GATE (WR GATE) enables data (WRITE DATA) to be written on the diskette. This data is a serial stream of MFM encoded signals. Before sending data to the disk drive, the data stream goes through precompensaton circuitry.

WR CLK clocks the FDC from the Phase Lock Loop (PLL). This signal occurs at a frequency of 500KHz, with the high level high for about 250ns, and the low level low for 1.75ns. Other outputs from the PLL circuits are VCO SYNC (inhibits VCO in PLL when low and enables VCO when high) and RDD DATA. VCO SYNC enables the RD DATA to the data separator whenever the FDC is doing a read operation. The other input to the data separator/phase-lock loop provides a signal for the phase-lock loop to lock onto when data is not being read.

When doing a read operation and the PLL loop is locked on, all RD or RDD DATA clock bits occur during one polarity of the DATA WINDOW, and all READ DATA bits occur during the opposite polarity.

The data bus DBO to DB7 into the UPD765 is bidirectional. The CPU sends commands and reads the FDC status through 8-bit status registers in the FDC. The relationship between the status registers, and the control and address signals is as shown below:

<u>AO</u>	<u>RD</u>	<u>WR</u>	<u>FUNCTION</u>
0	0	1	Read Status Register
0	1	0	Illegal
0	0	0	Illegal
1	0	0	Illegal
1	0	1	Read from Data Register
1	1	0	Write into Data Register

DISK SELECT from the system decoder is in conjunction with either BRD or BWR enables RD or WR ports of the FDC. DISK SELECT also generates an acknowledge signal (DACK) to the FDC. The CPU sends TC (terminal count) when the disk request is complete.

The FDC queues for an interrupt via INT to the CPU P10A.

2.6.2 CRT DISPLAY AND CONTROL

The control of the CRT display consists functionally of two principal areas:

- Video Timing and Control (VTAC) Chip
- CRT memory control

2.6.2.1 Video Timing and Control (Figures 2-7 and 2-8)

The display unit is a 12" CRT screen with a PCA for video input and scanning, and controls to adjust the display. The screen has a capacity of 1920 characters with 24 rows of 80 characters per row. Each row uses 11 scan lines of which 8 are characters, two are used for underscore and cursor, and one is the space between rows. Each character is a 7X8 dot matrix.

Inasmuch as there is a total of 24 rows with 11 horizontal scans per row, there are 264 scans per visible field. One scan line requires 58.5us which includes the retrace time to begin the next line.

To a total of 264 scan lines, an additional 21 scan lines are used for the vertical blank and vertical sync period. This permits a retrace of the scan to the top of the screen for the start of the next display field. The total time for a vertical scan plus retrace is 16.666 ms or 60 vertical scans per second. For horizontal retrace time, the character count is extended to 99 counts (11 usec.). During this time a horizontal blank (BL) pulse and horizontal sync (HSYN) pulse are generated.

The Video Timing And Control (VTAC) chip on the CRT/MEM PCA is the interface between the display monitor and CPU. It generates all the timing signals for the presentation and formatting of non-interlaced video data on the display unit.

The VTAC refreshes the CRT display by buffering the information from the CRT memory, and keeping track of the display character positions on the screen. To do this, it provides raster timing, display row buffering, attribute decoding, and cursor timing.

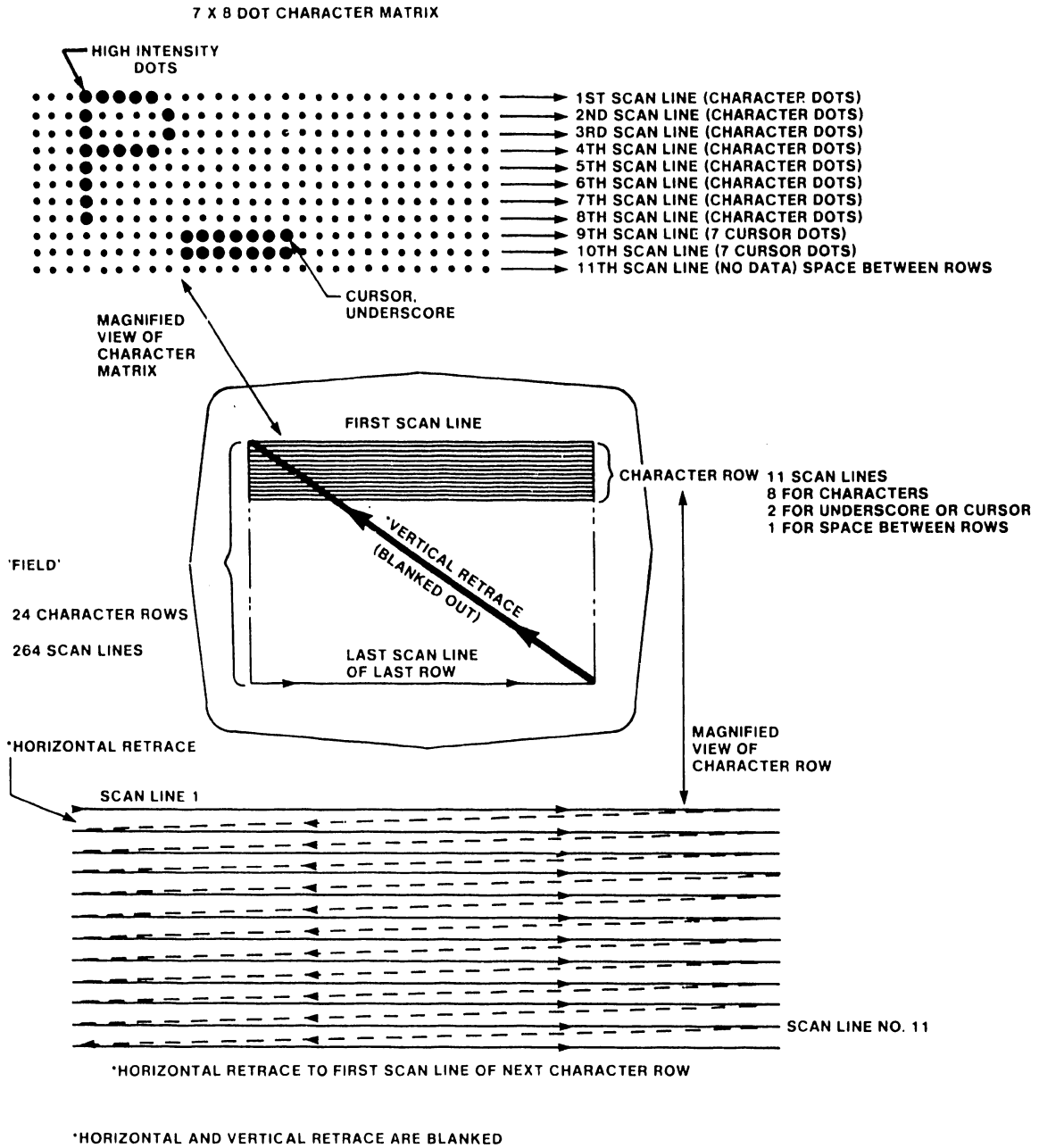

FIGURE 2-7 SCREEN FORMAT

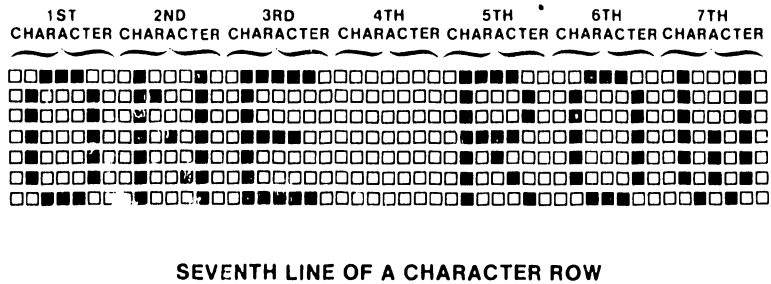
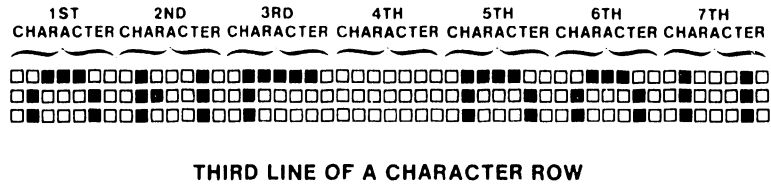
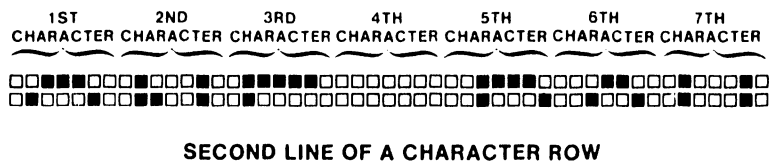
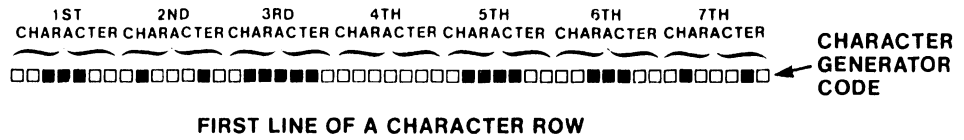

FIGURE 2-8 FORMATION OF CHARACTERS 5 x 7 MATRIX

The Z80A-CPU loads the VTAC during the system initialization with data from the system disk. The CPU loads the program in the VTAC as follows:

HEX Address	PROGRAM
40	Load horizontal load count
41	Load sync width, delay, interface
42	Load scan/data row, char/data row
43	Load skew bits, data rows/frame
44	Load scan lines/frame
45	Load vertical data start
46	Load last displayed data row
48	Read Cursor row address
49	Read Cursor character address
4A	VTAC reset
4B	Up scroll
4C	Load cursor character address
4D	Load cursor row address
4E	Start timing chain

The VTAC retrieves display characters from CRT memory for display on a row-by-row basis. The VTAC has two buffers. While one row buffer controls display, the other loads the next row of characters. The system disk programs the number of characters per row and the number of rows per frame. This is also true for the number of lines per character-row, the underline position, blanking of top and bottom lines, and raster timing.

Figure 2-8 shows character-forming details. Although Figure 2-8 shows a 5 X 7 character matrix, and the Wangwriter uses a 7 X 8 character matrix, the principle is the same.

As a character row line is scanned horizontally, the intensity of the CRT scanning beam is increased and decreased (modulated) under control of the character generators. The scan rate of the CRT, the CRT's persistence, and spacing of the dots in the letters combine to give the appearance of a solid letter rather than a group of individual dots. The VTAC controls the synchronous scanning; the character generator contains the code to control the intensity of the CRT beam that forms the characters. The complete formed characters are loaded into the separate CRT memory by the CPU.

2.6.2.2 CRT Memory Control (Figure 2-9)

The CPU selects the CRT RAM via an operations code 3. On Model 5503, the CPU generates CRT RAM SELECT with associated logic on the CPU board (see Figure 2-4); On Model 5504, the CPU generates CRT RAM SELECT by switching the address within bank three between system RAM and CRT RAM.

The CPU writes the CRT RAM via the attribute/character data buffer (bi-directional in Model 5503 only). A CPU read is via the data buffer (Model 5503) - or via the attribute/character latch (Model 5504).

When the CPU is not writing or reading the CRT memory, the VTAC addresses the CRT RAM with row 4 (R4) through R0 and character 6 (C6) through C0 via the address multiplexer. The character and attribute control signals are then simultaneously read from the internal busses of the CRT memory.

To display characters, the stored CRT memory data (addressed by the character and row counters in the VTAC) go to either the PROM (Model 5503 only) or soft programmable character generators (Model 5504 has only programmable character generators). The selected character generator is addressed by CA7-CA0 and SL3-SL0 (the sum of R3-R0 row select signals and derivatives of attribute signals). The output of the selected character generator is a dot-matrix coded signal representing a given line of the character to be displayed.

The parallel coded signal from the selected character generator is applied to the input of a shift register. Here, the serial dot matrix data is extracted and applied to the video circuits (CRT SSI CKTS).

The video circuits take the character data and synchronize it with the scanning signals developed in the VTAC. Also synchronized with the scanning signals are the attribute signals or control bits used for developing intensity, reverse video, underscore. These graphic and control signals are combined with the character data as part of the composite video sent to the CRT.

Cursor video (CRT output of VTAC) is combined with the scanning sync pulses derived from the VTAC chip. These synchronized video and control signals are presented to the display unit via a common coaxial cable from the CRT/MEM PCB.

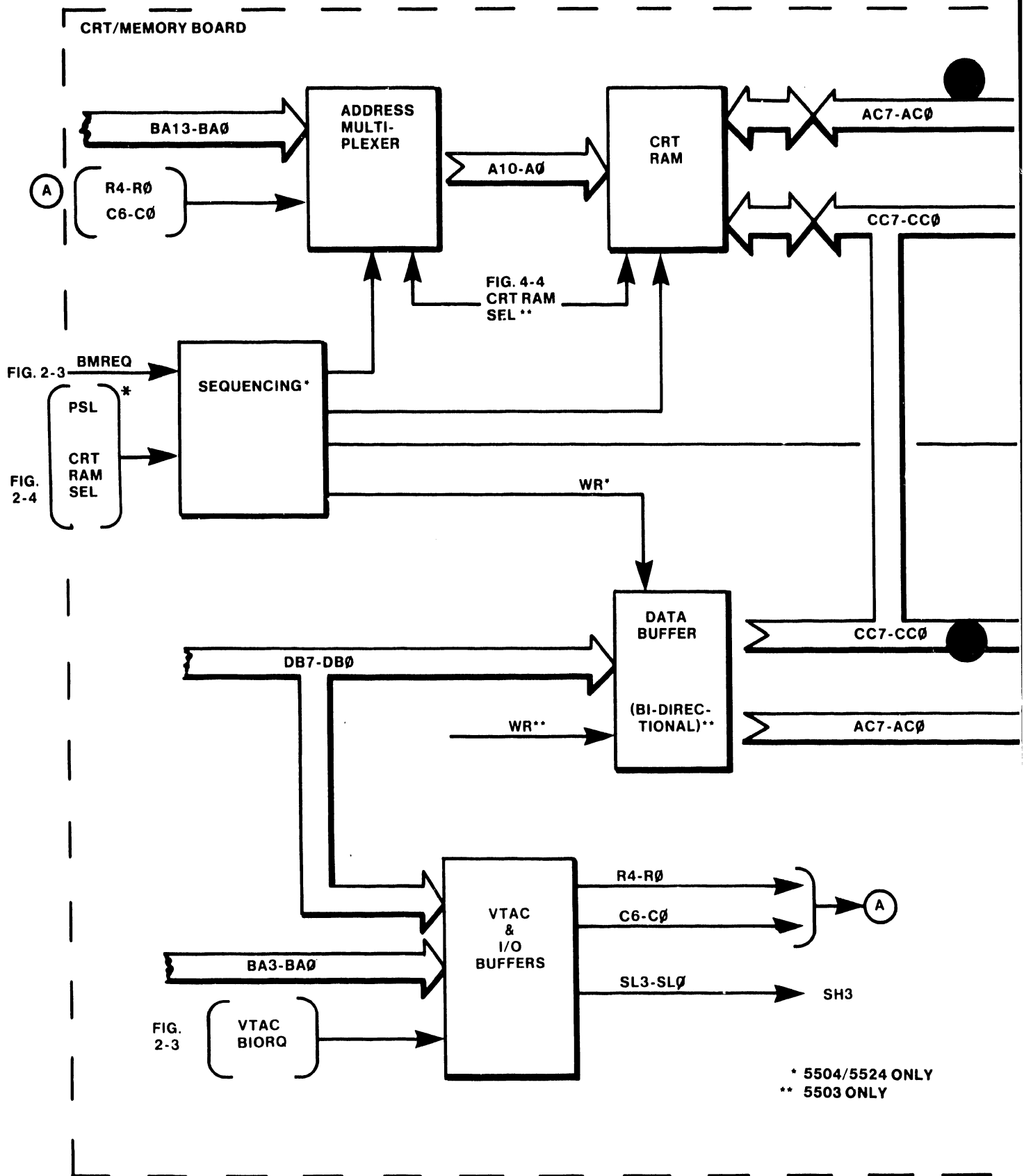

* 5504/5524 ONLY
 ** 5503 ONLY

FIGURE 2-9 CRT CONTROL (1 OF 4)

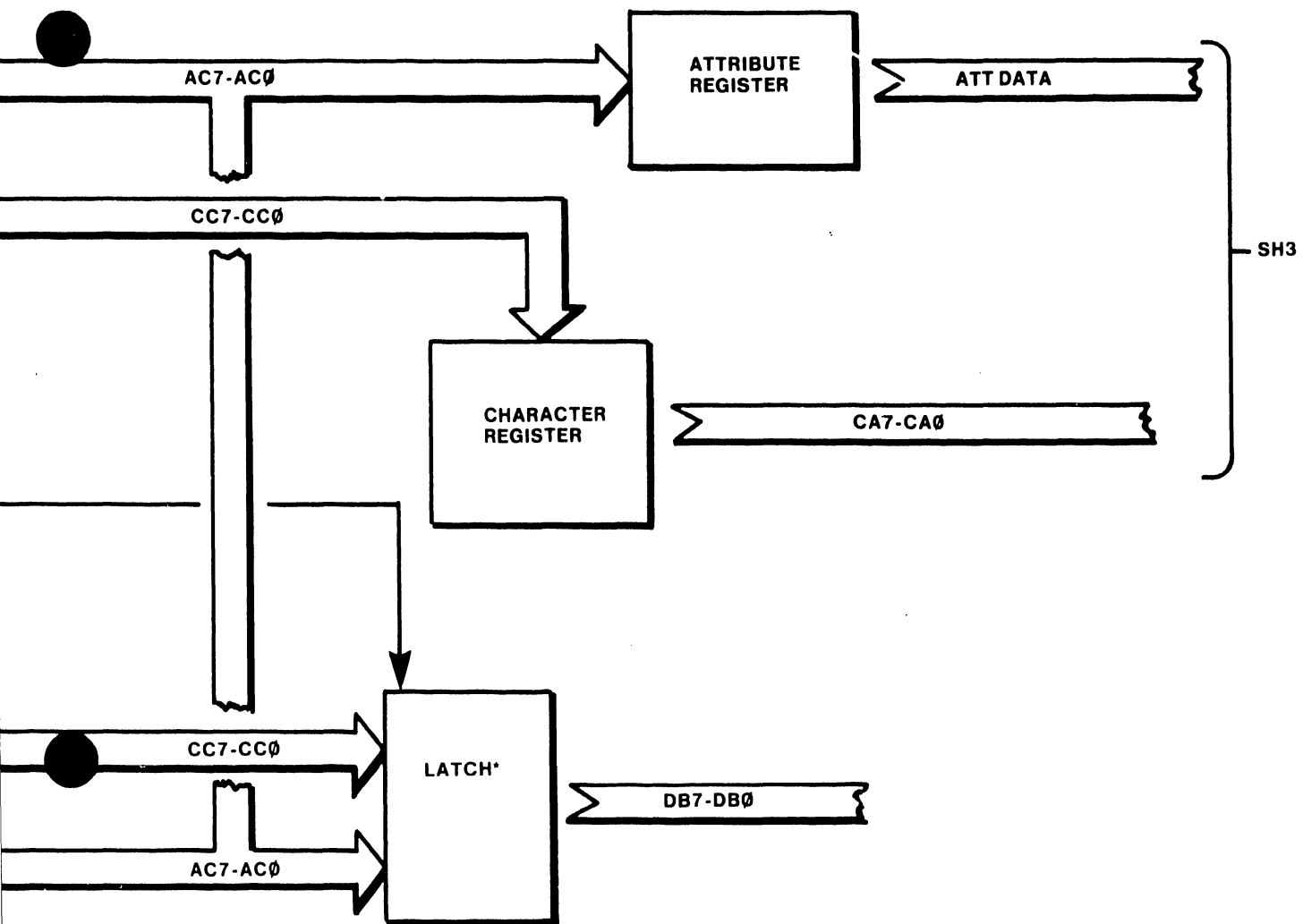

* 5504/5524 ONLY

FIGURE 2-9 CRT CONTROL (2 OF 4)

CRT/MEMORY BOARD

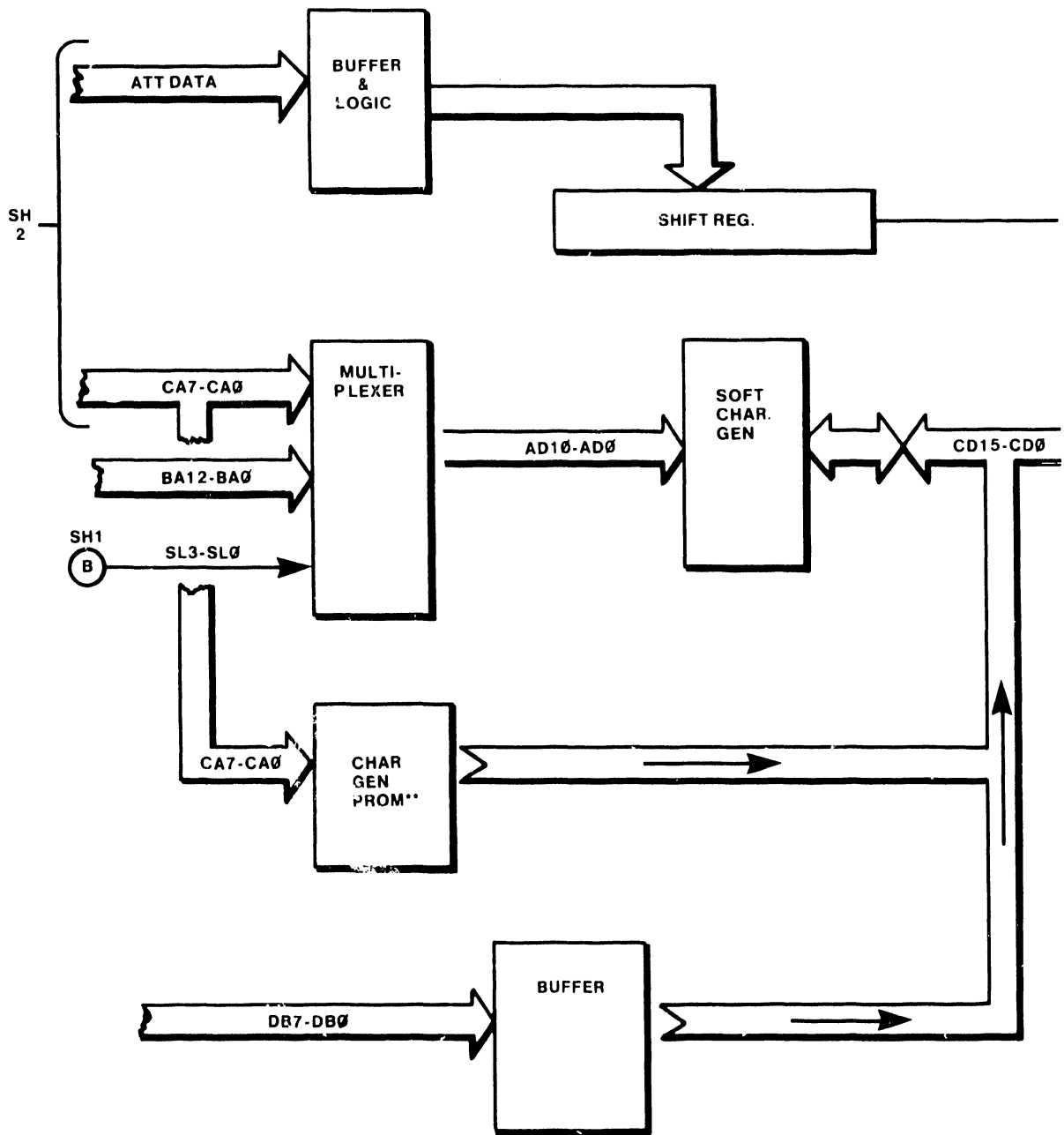

**5503 ONLY

FIGURE 2-9 CRT CONTROL (3 OF 4)

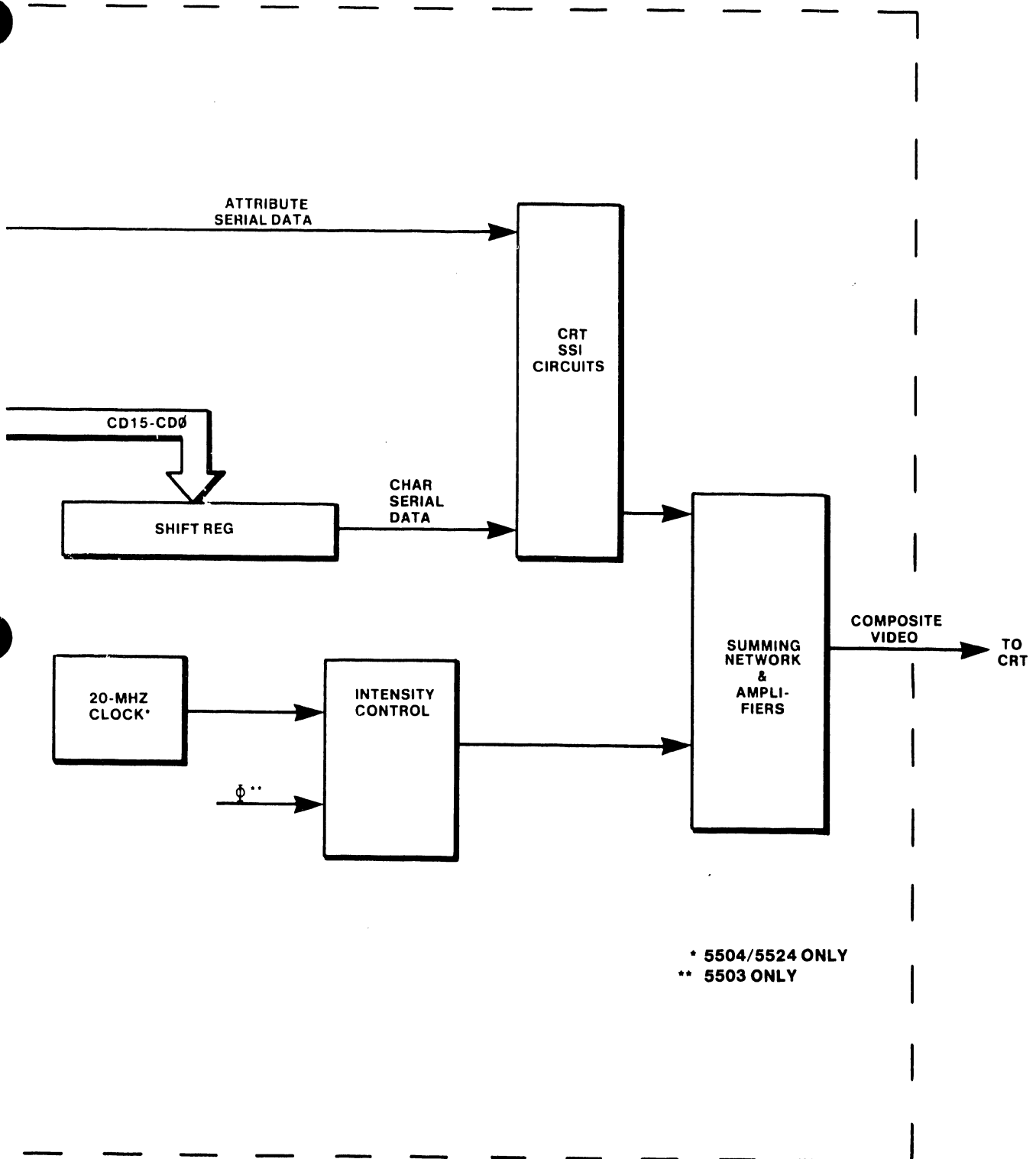

FIGURE 2-9 CRT CONTROL (4 OF 4)

2.6.3 PRINTING COMMUNICATIONS

The printer has five major circuits: Daisy printwheel, carriage, paper, ribbon and hammer. Four of the circuits are functionally alike; the hammer circuit differs but slightly. The hammer circuit uses a coil to activate the hammer; the other four circuits employ a stepping motor to drive the mechanics of the printer. Four-phase signals and a hold line control each stepper motor. CTC channels 0, 1 and 3 are used in the timer mode for timing the stepper motor phase changes.

The printwheel stepping motor positions the petals of the Daisy for printing. The carriage stepping motor moves the carriage (which carries the Daisy) in the horizontal plane. A paper stepping motor positions the paper in the vertical direction (line feed). The printing ribbon is also driven by a stepping motor. An energizing coil activates the hammer to strike the petal when the wheel and carriage are in the correct printing positions.

All these circuits, except the hammer circuit, are in a closed loop with the CPU. The CPU commands the servos to move the stepping motors to specific positions and the Printer PIO reports position status back to the CPU.

2.6.3.1 Data Input/Output (Figure 2-10)

The communications between the CPU and the printer are bidirectional. The CPU reads the status of the printer through the PIO chip on the printer PCA; the CPU drives the printer circuits through latching type ports.

The addresses of the A and B status ports of the printer's PIO chip are 50 and 51 hex, respectively. The latching printer input ports addresses are as follows:

Panel LEDs	--	54
Ribbon motor	--	5B
Daisy drive	--	58
Carriage	--	59
Paper drive	--	5A
Hammer fire	--	5C
Diagnostic display	--	5F

The CPU reads the status of the sensors and switches tied to port A of the printer PIO at address 50 (hex). At the input to L56 (Figure 2-3), BA4, and BA6 are high and BA5 is low, which puts the printer output low.

The low output of the decoder goes to the printer-driver decoder. With BA3 and BA2 both low, the 1Y0 output enables (CE) the printer PIO. If BA0 and BA1 are both low, the PIO sends port A data to the data bus. The CPU reads the bus data when RD and BIORQ are low; the data on the bus is the status of the right-margin sensor, left-margin sensor, ribbon-out switch, paper-out switch, and cover-open switch.

The Z80A-CPU reads the status of TOF, P LOAD, LF DWN, LF UP, R DOWN, R UP AND SEL (port B) switches in a similar manner. Input B7 of the PIO in the printer indicates that the 36V enable power is applied to the printer.

The CPU addresses the six printer input ports at hex 58, 59, 5A, 5B, 5C and 5F. For example, to send new positioning data to the Daisy wheel (hex 58), the address decoder L15(A) clocks the printwheel latching circuit. This latches the bus data from Z80A-CPU to the output terminals. In turn, D01 through D04 go to a drive amplifier which steps the Daisy printwheel stepping motor to a new printing position.

Four of the five signals from the latching circuits also feed the NAND circuits tied to an input to the fault amplifier. If the data from the CPU indicates a fault, the amplifier lights the board LED and disables the drive circuits.

2.6.3.2 Stepping Motors and Driving Amplifiers

The permanent magnet stepping motors contain a cylindrical, toothed rotor and a stator with wire-wound poles (Figure 2-11). Each stator pole has teeth which distribute the flux.

A permanent magnet motor operates by means of interaction between magnetic flux on the rotor and the magnetomotive forces generated by stator winding current. The stator windings of a stepping motor energize in a fixed pattern; therefore, there is a series of stable equilibrium points generated around the motor. The rotor always moves to the nearest of these points and remains there. When the windings are energized in sequence, the rotor follows the changing point of equilibrium and rotates in response to the changing pattern.

A typical stepping motor drive system gets drive (position) signals from the CPU and converts them to the proper format to energize the motor windings. The power amplifier (see Figure 2-12) drives high current through the windings, and a power return system removes the current from the windings at the end of each step.

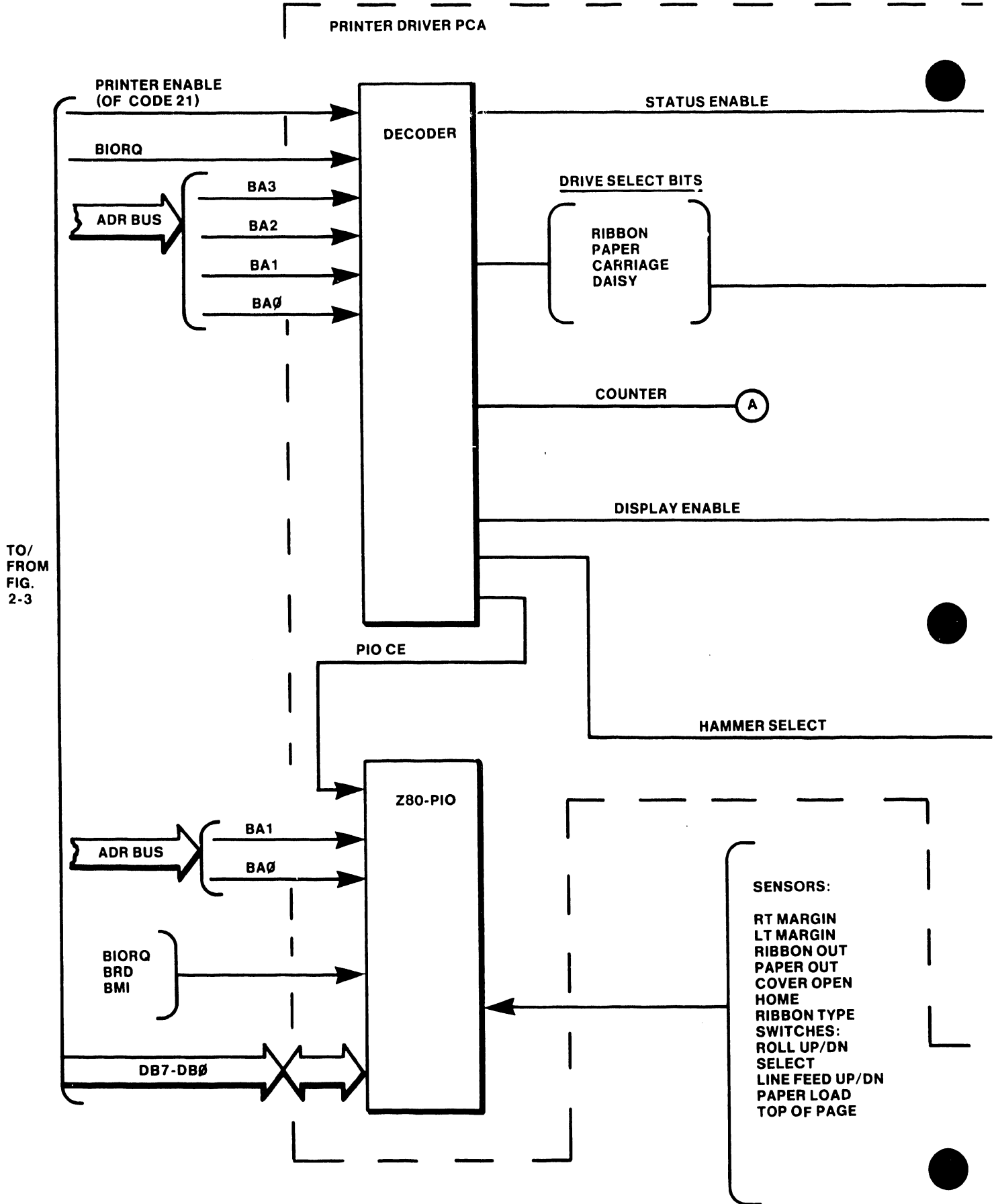

TO/
FROM
FIG.
2-3

FIGURE 2-10 PRINTER COMMUNICATIONS (1 OF 2)

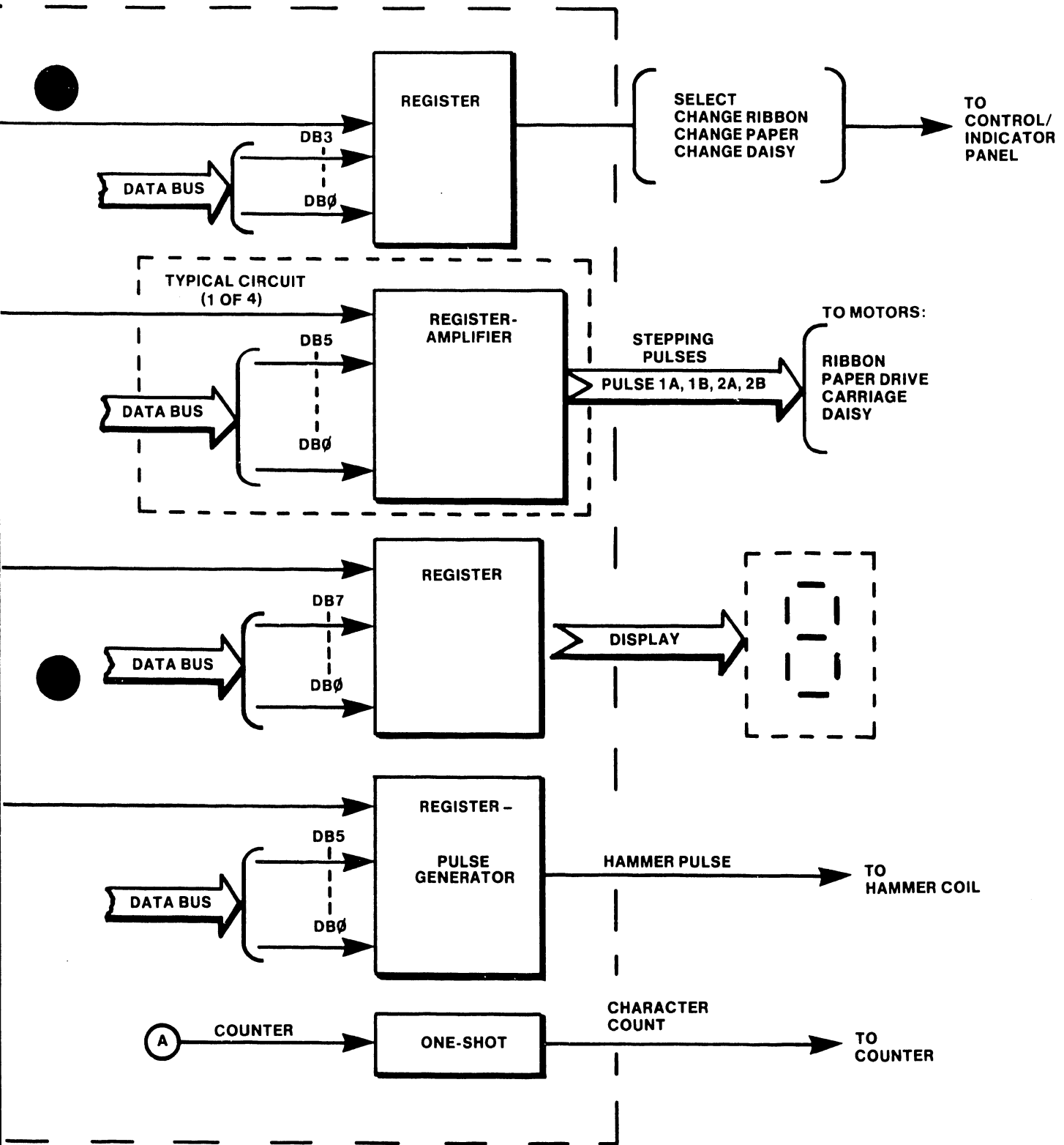

FIGURE 2-10 PRINTER COMMUNICATIONS (2 OF 2)

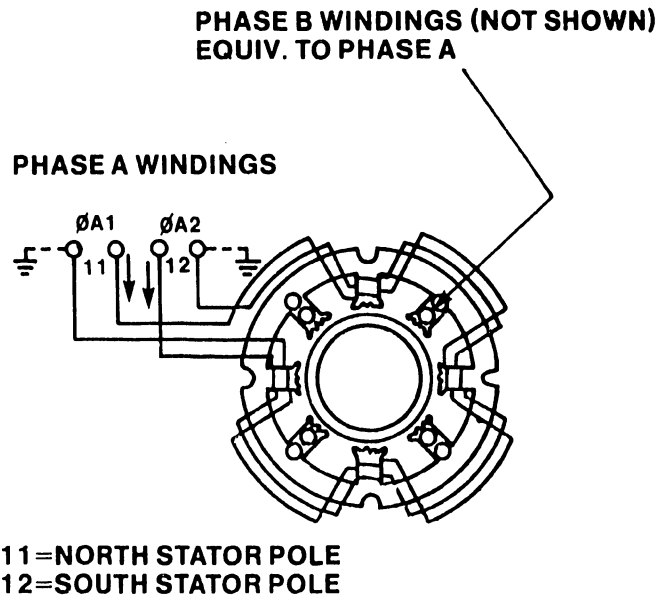

FIGURE 2-11 PERMANENT MAGNET MOTOR

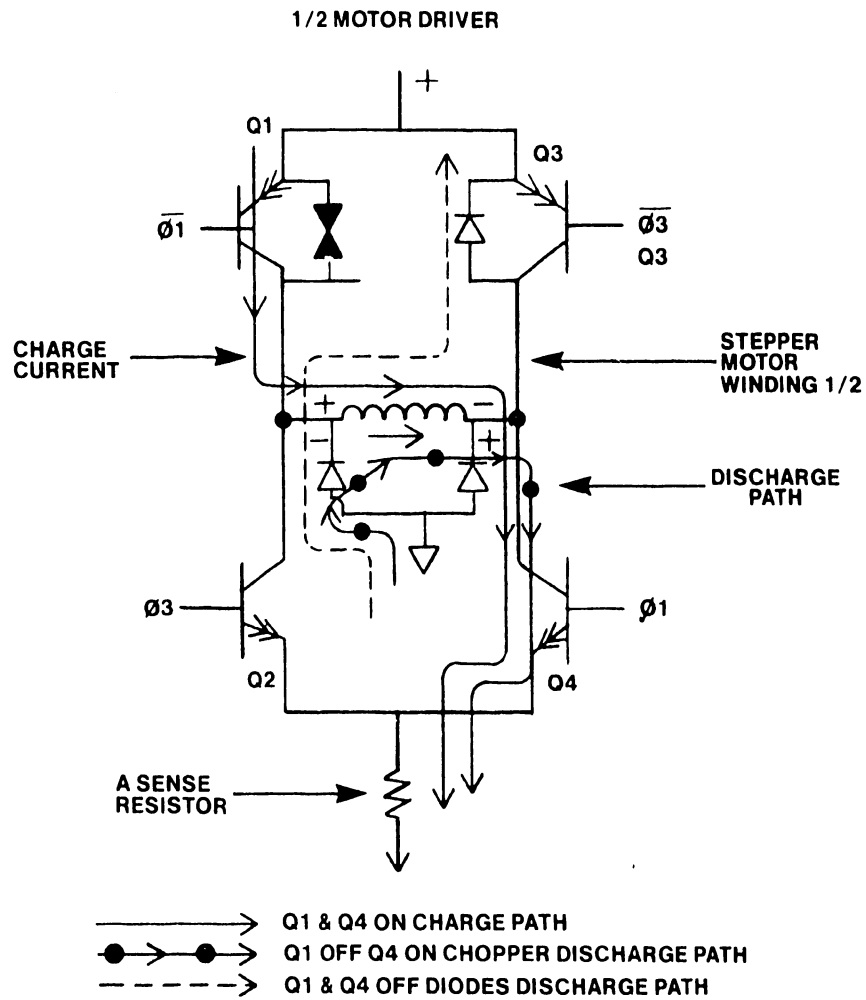

FIGURE 2-12 MOTOR DRIVER

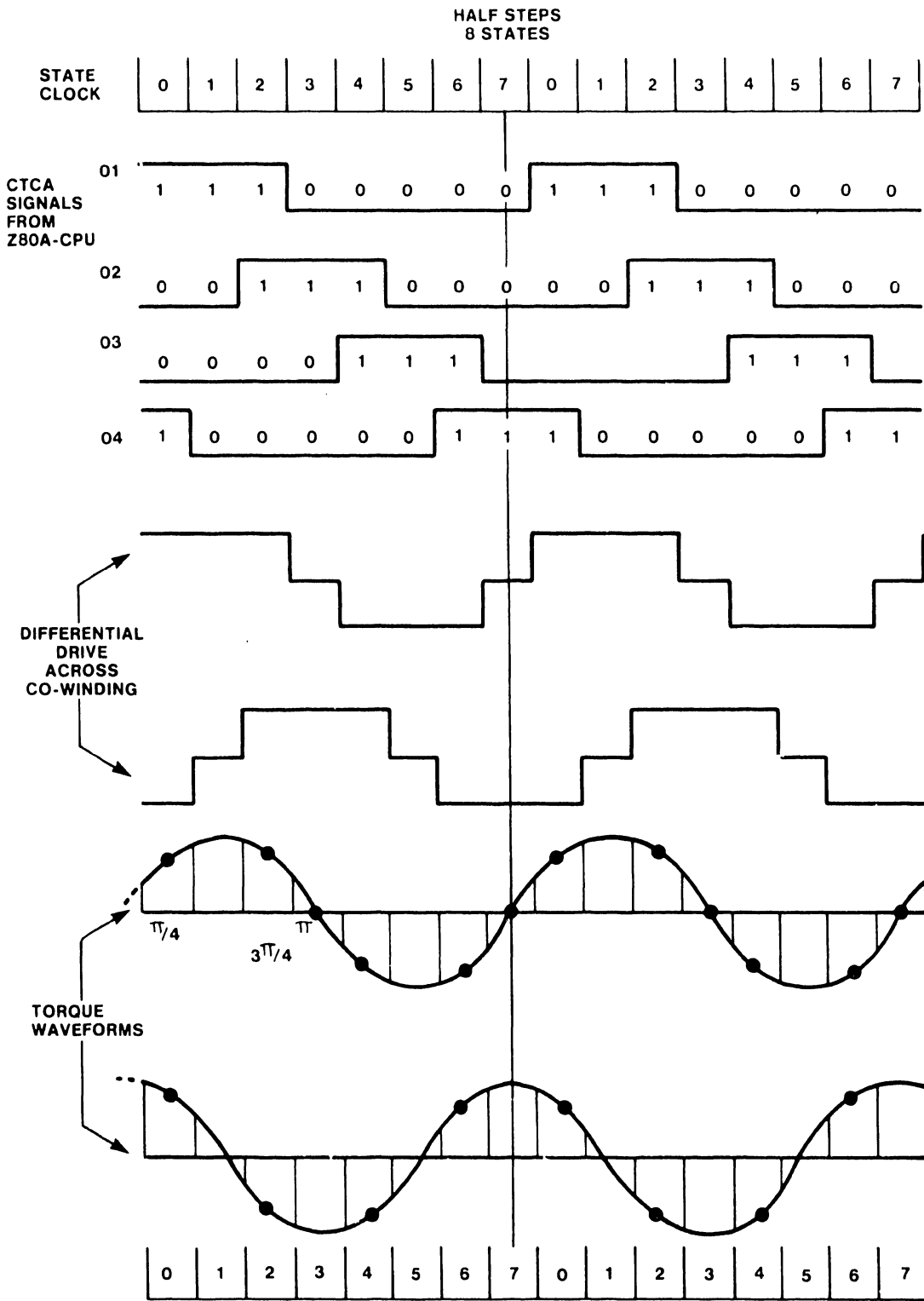

FIGURE 2-13 DRIVE AND POWER WAVEFORMS

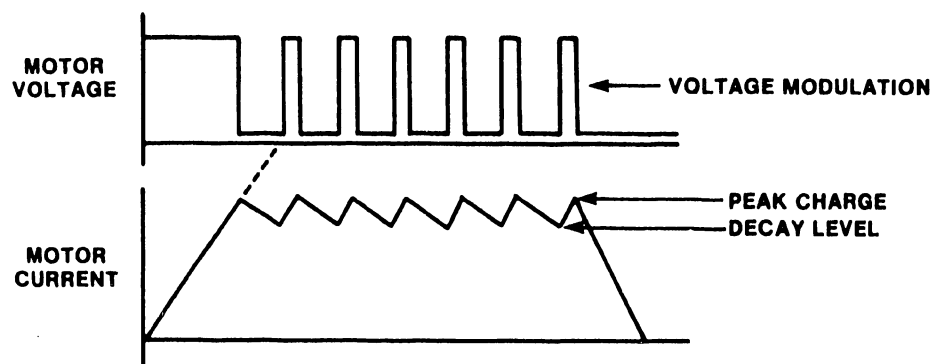

FIGURE 2-14 CHOPPER TECHNIQUE

Since the motor rotates in response to a changing patterns between the rotor magnetic field and the stator magnetic fields, a state generator (not shown) is necessary. The state generator establishes the proper sequence and pattern of states in response to a serial pulse train. The state generator then drives the power amplifiers to excite the stepping windings.

There are two drive sequences to step the motor. One, called a "WAVE" drive, energizes only one set of stator poles at a time. The other sequence, called two-phase drive, energizes both pole sets simultaneously. Either of these sequences step the motor by increments of N degrees, but when the two sequences are used alternately the motor moves in half steps. The half step is used in the Wangwriter system for better control of the stepping motors.

A voltage modulation, or chopper, technique is used for high efficiency motor driving. With this technique, the full voltage (36V) goes to a motor winding until the correct current level is reached (see Figure 2-13). The voltage then switches off, and the current circulates in the motor winding (see Figure 10). When the current decays to a predetermined level, voltage again goes to drive the current back to the correct level (see Figure 13). This cycle continues throughout the driving pulse time. At the end of the driving pulse, the motor winding current discharges.

This chopper technique is inherently well suited to start-stop applications such as the printer's carriage, printwheel, paper and ribbon circuits.

2.6.4 KEYBOARD COMMUNICATIONS (Figure 2-15)

The keyboard generates serial data which is converted to parallel data in the CPU's UART. The parallel data (K0 through K6 and shift) goes to the PIOA chip port A. The CPU reads this data from the data bus and then buffers it in the system memory. From here, the CPU retrieves the data and sends it to either the CRT or the diskette.

The keyboard unit has four major components: a capacitive keyboard, an encoder, a mutliplexer, and a UART. The keyboard unit sends character and control signals to the CPU in a serial format, and the CPU sends serial data such as alarm, clock, keyboard test and HSYNC to the keyboard unit.

The encoder is a dual-pulse scanning encoder and controller for the capacitive keyboard. It contains a 4K ROM for programming, a 128-bit shift register, and an internal oscillator.

The scan control, consisting of an encoder and a multiplexer, scans the keyboard matrix. The encoder provides a 3-bit address (YA, YB, and YC) for scanning each of the eight sense lines (Y lines). The drive lines (X lines) are each pulsed low by the encoder.

When a key is pressed, a pulse is coupled from the drive to the sense lines for that key, then amplified and sent to the encoder. A detection circuit is used between the output of the multiplexer and the input to the encoder. In this manner, each matrix cross-point is interrogated in turn. An internal oscillator controls the matrix scanning rate.

2.6.5 FOREGROUND TELECOMMUNICATIONS - MODEL 5504 (Figure 2-16)

The foreground telecommunications (FTC) provides an interface between the system data bus and a transmission modem. Additionally, the FTC simplifies high-speed data transfer between memory elements and diskette storage. The FTC components are housed on the optional fourth PC board.

The FTC board contains the following principal components:

- Direct memory access (DMA) chip - capable of simplifying high speed data transfers between peripheral devices and the memory, or between memory locations. When the program initiates use of the DMA chip (DMA mode), the DMA chip generates sequential memory addresses thus allowing the given peripheral to read or write data directly to or from memory.
- Serial input/output (SIO) chip - provides the serial-to-parallel (and vice versa) conversion necessary to interface between the internal bus and the transmission line control. The SIO chip has two separate channels allowing for full duplex (send/receive) capability on each; however, only one section of each channel is used. Channel A is the receiver channel, and channel B is the transmitter channel. The FTC board thus contains one full duplex communication channel. Via the communication channel, the SIO chip:
 - Converts eight-bit parallel to one of several serial formats.
 - Supports synchronous line disciplines of both bit-oriented protocols and character oriented protocols.

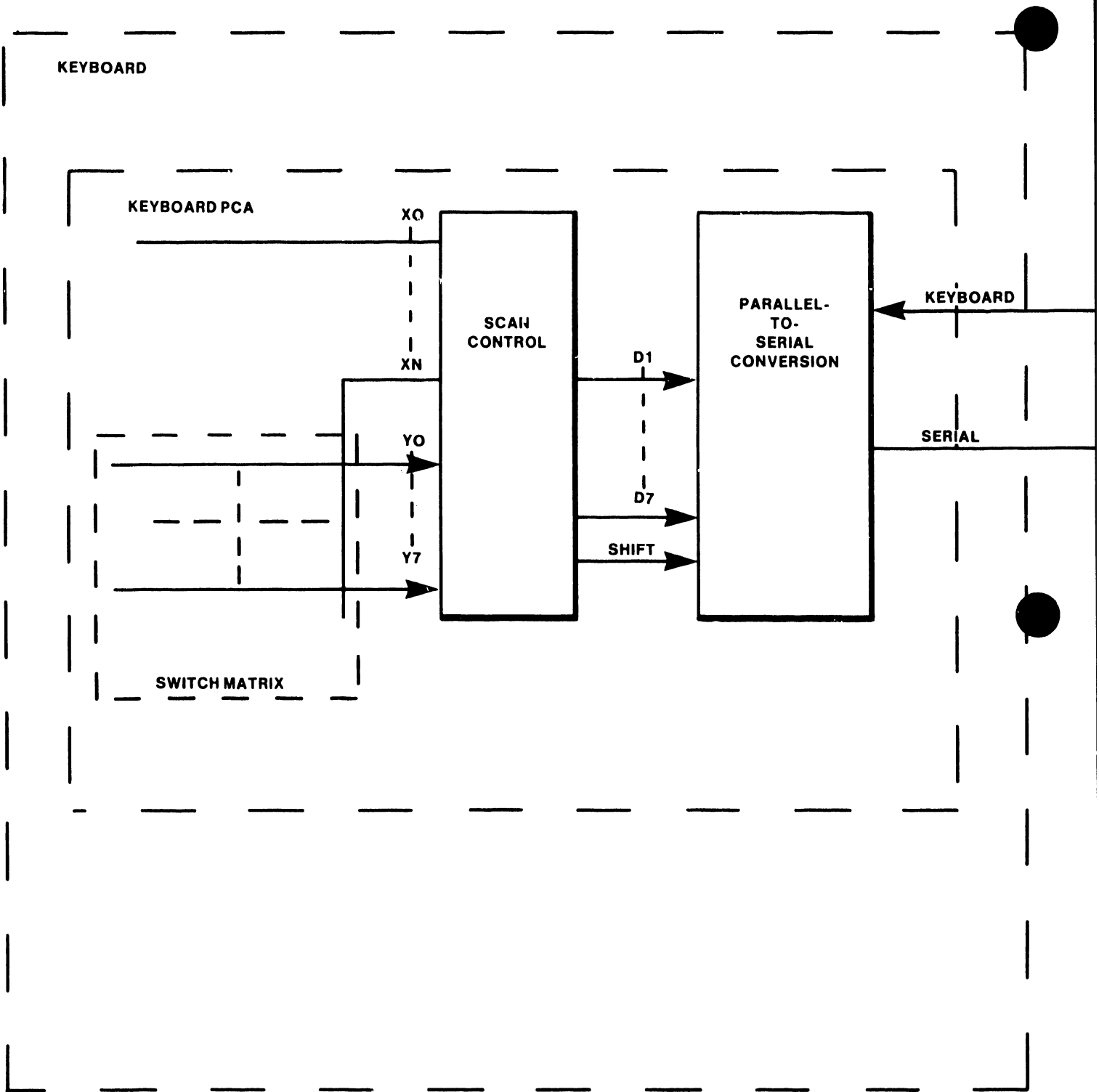

FIGURE 2-15 KEYBOARD COMMUNICATIONS (1 OF 2)

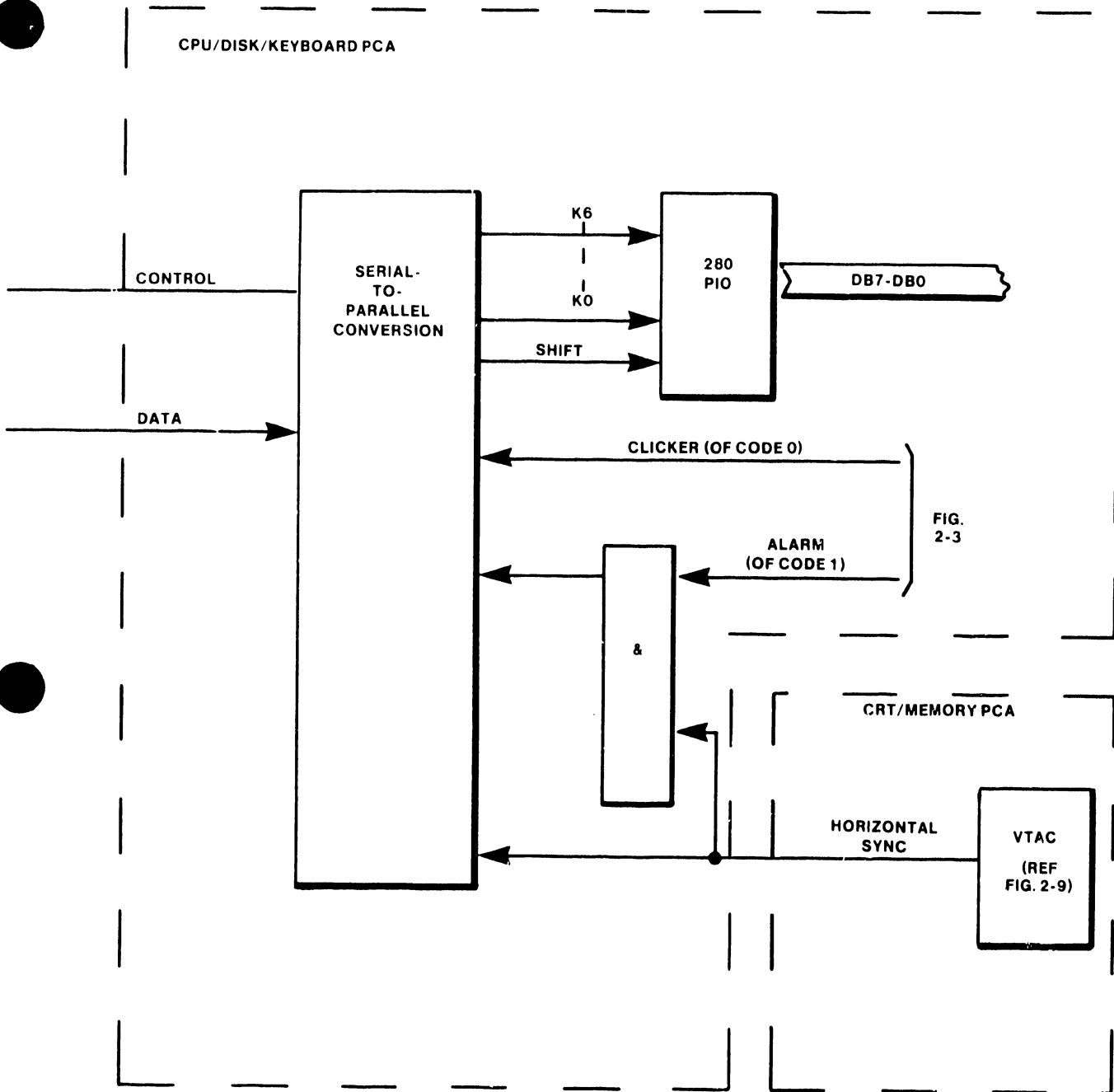

FIGURE 2-15 KEYBOARD COMMUNICATIONS (2 OF 2)

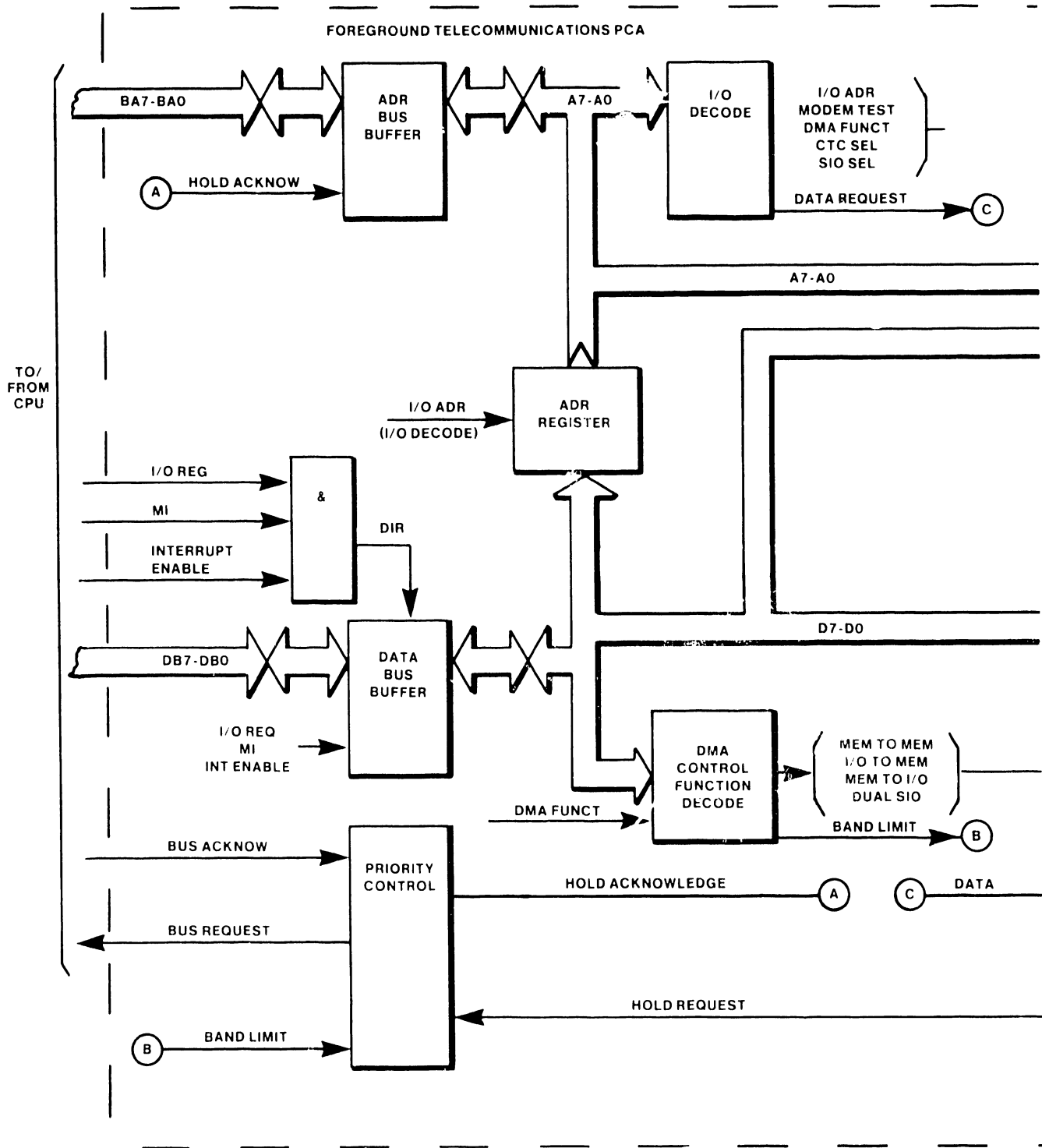

FIGURE 2-16 TELECOMMUNICATIONS (1 OF 2)

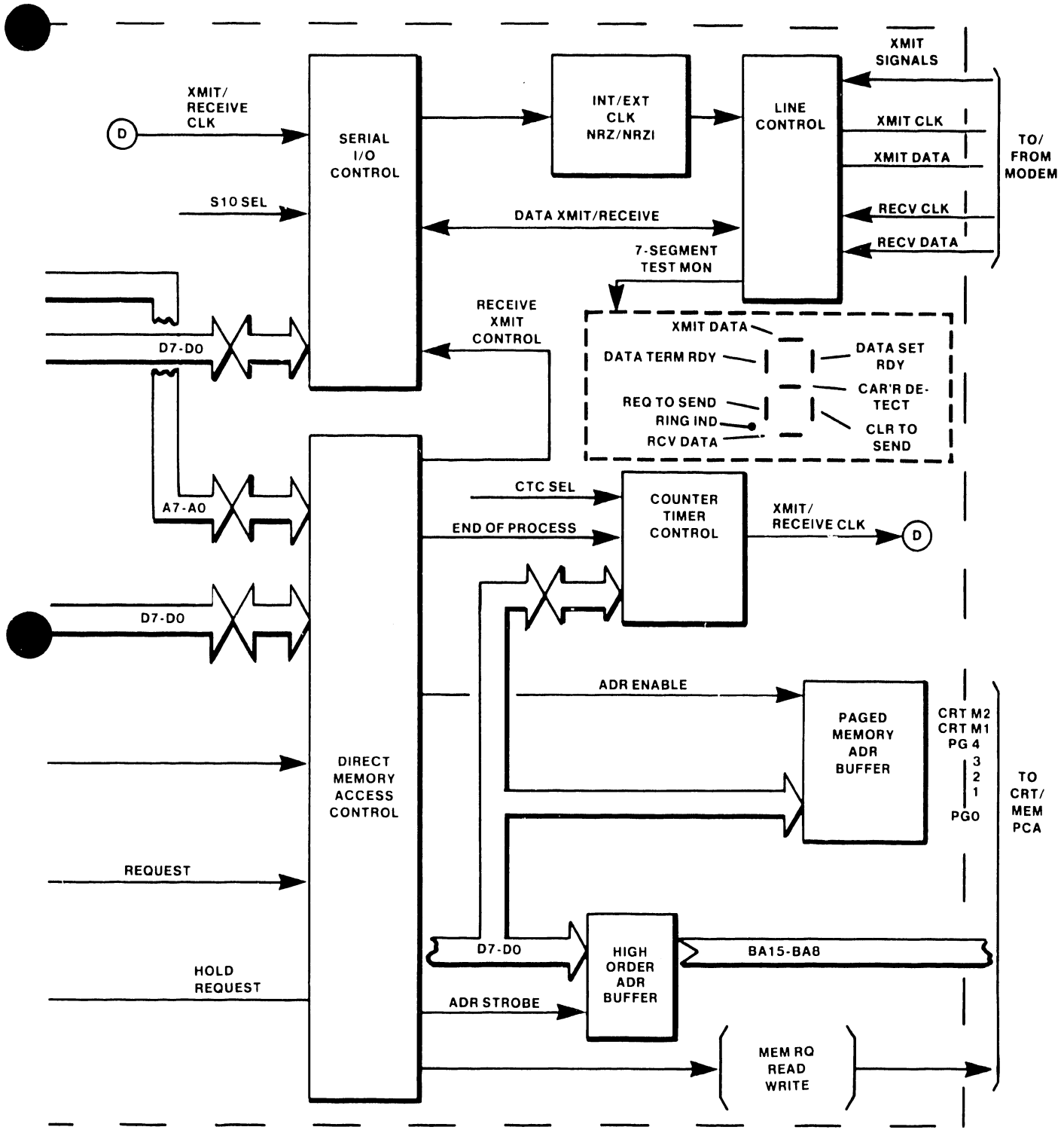

FIGURE 2-16 TELECOMMUNICATIONS (2 OF 2)

- Supports asynchronous line disciplines allowing for start/stop bits, five-bit through eight-bit data fields and a parity bit.
- Provides line control and status monitoring with error protection and detection.
- Counter/Timer Controller (CTC) chip - provides the matching of the system internal timing to the baud-rate required by the given transmission format used. Via a programmed counter/timer mode, the CTC divides system clock frequency by a constant to derive the appropriate transmit/receive clock. The transmit/receive clock controls the SIO and line control transmission rates. Additionally, the CTC interrupt structure flags the system CPU at completion of transmit/receive operations.

The FTC board does not contain a processor; all program commands configuring the FTC emanate from the main system CPU. The telecommunications operations perform in "foreground" mode in that an FTC operation requires suspension of other CPU and bus functions for the duration of the communication.

The FTC operates principally in two modes:

- Direct memory access - used for high-speed data transfer between the minidiskette and system memory, and between memory locations.
- Interrupt - used to control transmission/reception of data to/from the transmission modem.

2.6.5.1 Direct Memory Access

In direct memory access mode, the DMA chip by means of programmed sequences controls the transfer of data between the system memory and peripheral devices (e.g., diskette, and telecommunications input/output). Upon a data request, the DMA generates a sequential memory address, thus allowing the peripheral to read or write data directly to or from memory.

The DMA chip, in conjunction with the CTC transfers data:

- Diskette to memory
- Memory to Diskette
- Memory location to memory location

The system CPU initiates a DMA cycle by generating a data request via the system address bus. The FTC board decoding applies the data request (DREQ) to the DMA chip to initiate the following sequence:

- The DMA chip generates a hold request (HRQ); subject to band-limiting restrictions, HRQ places a signal, bus request (BUSRQ), upon the control bus. (Band limiting is for the purpose of slowing the rate of data transfers to match the rate limitations imposed by diskette data handling characteristics.)
- Upon completing the current operation, the CPU responds to the bus request by suspending operations and becoming, in effect, isolated from the address/data bus. The CPU sends a bus acknowledge (BUSACK) to the FTC controls.
- The bus acknowledge generates hold acknowledge (HLDA), internal to the FTC board. HLDA reverses the direction of the address-bus buffers, effectively placing DMA address outputs onto the system address bus.
- The DMA chip outputs the least significant eight address bits, A7 - A0, which go directly onto the address bus.
- The DMA chip outputs the most significant eight bits, A15 - A8, which latch into the high-order address buffer for application to the high-order address bus.
- The DMA chip generates the appropriate memory and I/O read/write control signals to transfer data between peripheral and memory, or between memory locations. This process continues until the DMA has counted down the number of bytes it has been programmed to send. At that time, the DMA sends an end-of-process signal to the CTC chip; the CTC chip sends an interrupt to the system CPU.
- The CPU cancels bus acknowledge; the DMA control cancels HRQ (which resets HLDA) reversing the direction of the address bus buffers. At this point, the DMA control is inactive pending a subsequent data request via the address bus.

2.6.5.2 Interrupt Mode

Interrupt mode uses the SIO chip interrupts. The system CPU retains control of the address/data bus; the CPU controls data exchange with the transmission modem via the system interrupt structure.

The FTC board has the lowest interrupt priority in the system (see paragraph 2.5). Within the FTC board, the SIO chip sets priority on changes in status as follows:

Data being received - top priority

SIO available for more data

Detected changes in transmission status - lowest priority

In the interrupt-driven mode, the CPU thus services the FTC as the lowest priority peripheral in the interrupt structure (see paragraph 2.5 for description of interrupt-driven routines)

2.7 SINGLE SHEET FEEDER OPERATION:

The Single Sheet Feeder consists of a mechanical assembly, mounted on the Wangwriter printer console, for the automatic dispensing of paper to the printer.

The feeder has neither electronics nor motors. Mechanical attachment to the printer platen drive gear provides feeder drive and control. System software, responding to printer paper sensor status, initiates the feeding of each new sheet of paper. The software commands reverse the platen motion, causing paper to feed from the feeder to the platen. The platen then pulls the paper into print position, without manual intervention.

A removeable cartridge holding approximately 100 sheets of paper provides for the insertion of paper into the feeder. A metal plate mounted on the paper tray assembly minimizes static electricity effects upon the feeding of individual sheets of paper.

CHAPTER

3

**OPERA-
TION**

CHAPTER 3

OPERATION

This chapter describes:

- Controls and Indicators
- Loading the operating system
- Inserting the archive disk
- Creating a document
- Printing a document
- Shutting down the system

The Wangwriter operating systems consist of word processing plus system options of data processing (C/PM) and/or telecommunications. Additionally, a diagnostic operating system provides the means of testing system components. Each operating system loads into system memory from a minidiskette (system diskette).

The following instructions apply to all Wangwriter models unless otherwise noted. Principal differences lie in the operation of single-disk versus dual-disk systems; in dual-disk systems the system diskette remains in the lower disk drive throughout a given operation; in single-disk systems, the archive diskette replaces the system diskette following operating-system loading.

3.1 CONTROLS AND INDICATORS

See Table 3-1 and Figure 3-1 for a description of Wangwriter controls and indicators. For keyboard function, refer to the specific instructions for the given operating system (e.g., word processing).

3.2 LOADING THE OPERATING SYSTEM

- General Notes:
- On system diskettes, the write-protect slot is not covered.
 - On archive diskettes, the write-protect slot must be covered with a tab.

Table 3-1
Controls and Indicators

<u>CONTROL/INDICATOR</u>	<u>FUNCTION</u>
Control Panel	
POWER Indicator	Indicates that system power is turned on (+5V supply active)
CHANGE RIBBON Indicator	Indicates that end of ribbon has been reached.
CHANGE DAISY Indicator	(Potentially, depending upon software) indicates a programmed interrupt to a printout for the purpose of changing print characteristics.
CHANGE PAPER Indicator	Indicates paper-load tray empty, with printer selected (manual feed only).
LINE FEED Control (up/down)	Rolls paper either up or down one line at each actuation.
ROLL Control (up/down)	Rolls paper either up or down continuously as long as control is held depressed.
SELECT Control	Alternately initiates and terminates printer action.
TOP OF PAGE control	Returns printer to beginning of page interrupted by last deselection of printer.

LOAD RUN
KNOB



CONTROL PANEL

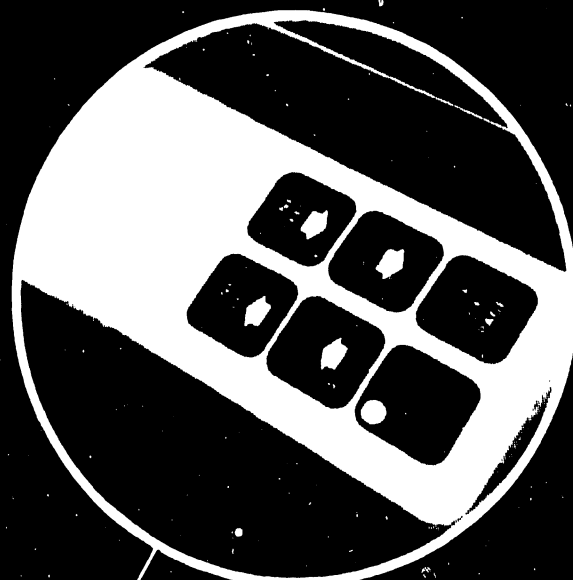

PAPER LOAD
LEVER



COVER RELEASE
SPRING



DISK IN USE
INDICATOR

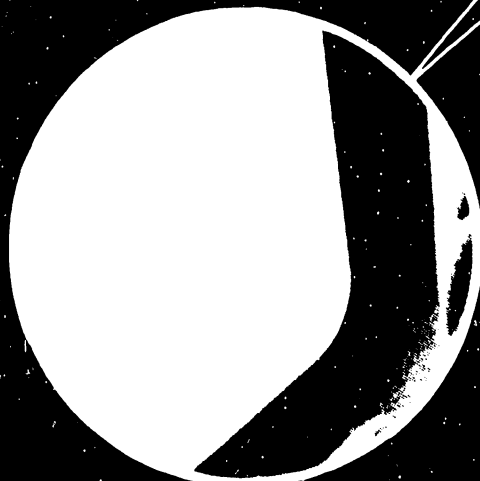

POWER
SWITCH

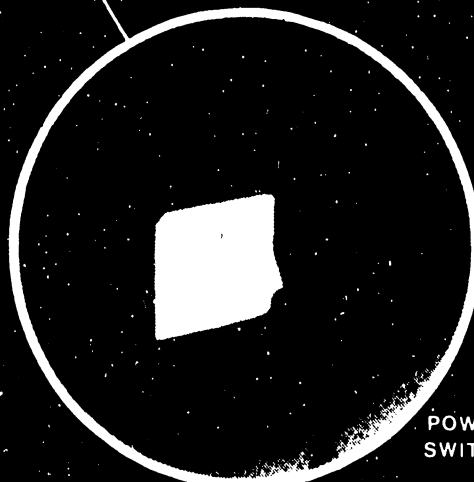

FIGURE 3-1 CONTROLS AND INDICATORS

Table 3-1 (continued)

Controls and Indicators

<u>CONTROL/INDICATOR</u>	<u>FUNCTION</u>
LOAD/RUN control	Alternately enables the insertion of paper-holding cartridge (LOAD position) and the automatic dispensing of sheets onto the printer platen during print operation (RUN position).
Paper Load lever	Initiates paper feed into beginning-of-print position (manual only).
Disk-in-Use indicator	Indicates that door to respective disk drive is locked (disk not to be removed until indicator goes dark).
Power switch	Applies/disconnects primary power to system. POWER indicator should light when "1" position is pressed.

3.2 LOADING THE OPERATING SYSTEM (continued)

- The protective shield of all diskettes should have arrows indicating direction of diskette insertion into the disk drive. If no arrows, position write-protect slot at the bottom nearest the door (see Figure 4-5).
- System diskette goes into lower disk drive (dual-disk-drive systems only).
- Archive diskette goes into upper disk drive (dual-disk-drive systems only).
- Should an archive diskette be inserted into the disk drive for the for the system loading sequence, the CRT prompts: "Wrong Disk". In this case, reinitiate start-up procedure.

<u>SEQUENCE</u>	<u>OBSERVATION</u>
1. Press "1" on the red power switch.	POWER light turns on.
2. Insert system disk in the drive slot and close door (see Figure 2-5).	Operating system menu appears on CRT (unless 10-second interval elapses between step 1 and step 2 - Wangwriter I models only. In this case, turn off power and repeat procedure).
3. If a single-disk-drive system, open drive door and withdraw diskette.	

3.3 ARCHIVE DISKETTE INSERTION

<u>SEQUENCE</u>	<u>OBSERVATION</u>
1. Insert archive diskette; Press space bar to position acceptance block to desired activity (or leave acceptance block at default position). Press EXECUTE.	CRT prompt: "Press EXECUTE when archive disk is in drive"
2. Press EXECUTE.	CRT displays either submenu or message pertaining to selected activity. Should archive diskette be either missing or improperly inserted, CRT prompts: "Drive not ready". In this case, insert diskette properly; press EXECUTE.

3.4 CREATING A DOCUMENT

The following comprises minimum steps necessary for the creating of a document to verify operation. For in-depth instruction, refer to the Wangwriter Operator's Manual.

- General notes:
- A document name may have any combination of letters and numbers (up to eight characters).
 - Each name must be unique. At least one letter/number must differ from all other document names (on the given archive disk).

<u>SEQUENCE</u>	<u>OBSERVATION</u>
1. Press space bar to place acceptance block at "Create New Document" on the start-up menu.	CRT prompts: "Enter Document Name"
2. Enter document name; Press EXECUTE.	CRT displays blank page.
3. Enter text.	CRT displays typed text.
4. To terminate the Create activity, press CANCEL	CRT prompts: "End of Edit?"
5. Press EXECUTE	CRT message: "Rearranging" - followed by display of start-up menu.

3.5 PRINTING A DOCUMENT

The following comprises the necessary steps for the printing of a short (one-page) document to verify printer operation. For in-depth instructions, refer to the Wangwriter Operator's Manual.

- General notes:
- Ensure that the printer is deselected (SELECT switch dark) prior to paper insertion.
 - Steps 1 through 4 pertain to Single Sheet Feeder operation only. For manual insertion of paper, commence with step 5.

<u>SEQUENCE</u>	<u>OBSERVATION</u>
1. With the paper cartridge outside the feeder, fill cartridge (grade and size of paper specified on front of each cartridge). Paper goes between front and back paper catches.	
2. On feeder, turn LOAD/RUN knob to LOAD.	
3. Lower cartridge into feeder; slide cartridge track along cartridge guide on feeder interior surface.	
4. Turn LOAD/RUN knob to RUN.	
5. Press space bar to place acceptance block at "Print Document"; press EXECUTE.	CRT prompts: "Enter Document Name".
6. Enter exact document name; press EXECUTE.	CRT displays print menu
7. Press EXECUTE - or if using Single Sheet Feeder, press RETURN key to step acceptance block to Paper Load field. Press space bar to select Feeder. Press EXECUTE.	CRT displays start-up menu; CHANGE PAPER indicator lights.

3.5 PRINTING A DOCUMENT (continued)

<u>SEQUENCE</u>	<u>OBSERVATION</u>
8. Manual operation: Place paper in feed tray; pull paper-load lever forward and hold until the platen stops feeding paper.	Platen pulls paper into printing position.
9. On the printer console, press SELECT.	SELECT switch lights. Printer commences printing (if feeder is used, platen receives a sheet from the feeder and pulls the sheet into printing position; printing commences automatically). Printer stops after ejection of sheet (or after ejection of final sheet of document if using single sheet feeder).

3.6 SHUTTING DOWN THE SYSTEM

1. On the printer console, press SELECT to deselect the printer.	SELECT switch goes dark.
2. Press space bar to position acceptance block to "Remove Archive Disk."	Disk-in-Use indicator goes dark, and prompt "Remove Archive Disk" appears on CRT.
3. Remove archive disk; set Power switch to off position.	POWER indicator goes dark.

CHAPTER

4

INSTAL-

LATION

CHAPTER 4
INSTALLATION

- This chapter describes:
- Site requirements/recommendations
 - Environmental considerations
 - Unpacking
 - System Interconnections
 - Inspection
 - Initial turn on/power-up diagnostic
 - Single Sheet Feeder installation
 - Foreground Telecommunications (FTC) installation

4.1 SITE REQUIREMENTS/RECOMMENDATIONS

- Power required: 115 VAC (+10%, -15%) at 60 Hz
- or
- 220 VAC (+10%, -15%) at either 50 or 60 Hz
- Power connector: Receptacle to accommodate three-pronged plug.
 - Cable lengths:
 - Keyboard to printer 10 feet
 - Display terminal to printer 10 feet
 - Main power cord 6.5 feet
 - The floor-standing printer console should be to the right of the monitor. This allows convenient access to the diskette drives, printer control panel, and the ON/OFF switch.

4.2 ENVIRONMENTAL CONSIDERATIONS

The normal business environment, free of excessive dust, and extremes of temperature or humidity, offers satisfactory conditions for optimum system operation. specific requirements are:

- Ambient temperature of from 15 degrees C to 28 degrees C (60 degrees F to 80 degrees F). Situate the system so as to avoid operation in direct sunlight.
- A relative humidity of from 35% to 65%.
- A Minimizing of the effects of static electricity either by operating the system in an uncarpeted area or by treating carpets with anti-static spray. The use of furniture with anti-static upholstery and metal wheels may also minimize the effects of static.

4.3 UNPACKING

Refer to Figure 4-1 for orientation as to number of containers and proper unpackaging sequence. No special precautions are necessary for the ensuring of equipment integrity and personnel safety.

4.4 SYSTEM INTERCONNECTIONS

After unpacking the system, place the system units in their planned locations and connect in accordance with Figure 4-2. If the FTC board is to be installed, remove the Memory, CPU, and Printer-Driver boards; remove one filler plate from the rear panel. Install the FTC Board, then reinstall the other boards; remove one spacer from each board mounting stud (See paragraph 4.8 for further instructions on installation of the FTC).

4.5 INSPECTION

Verify all connections as shown in Figure 4-3. Refer to Chapter 5, if necessary, for instructions on gaining access to the card cage and the power supply compartment.

On the CPU board (210-7777/7977), set the eight-place switch 1 bank in accordance with system requirements. The configuration of the 5503 is switches 1 and 2 ON, 3 OFF; the configuration for the 5504 is switches 1, 3, and 6 ON, 2 OFF. Switch 4 is on for dual-disk units (see Figure 4-4 as example):

Switch Bank 1 Settings

<u>SWITCH</u>	<u>FUNCTION</u>
4	ON for a two-disk-drive system (5503 and 5504)
5	ON for FTC option (5504 only)
6	ON for Wang Daisy (5504 only)
7	ON to enable parallel printer PC board (5504 only*)
8	ON when spelling chip is in system (5504 only*)

*Option not available



FIGURE 4-1 WANGWRITER UNPACKAGING (1 of 6)

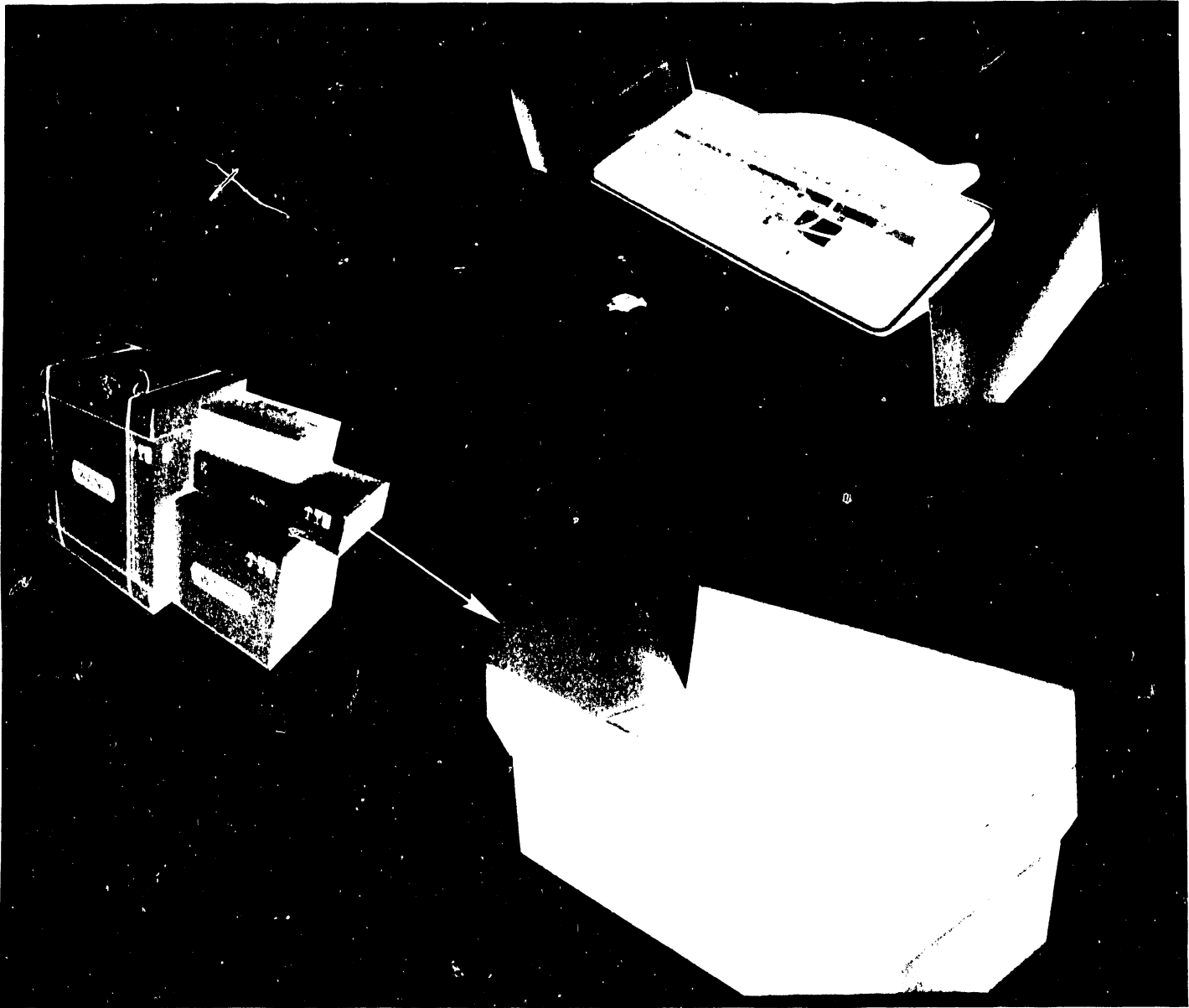

FIGURE 4 -1 WANGWRITER UNPACKAGING (2 OF 6)

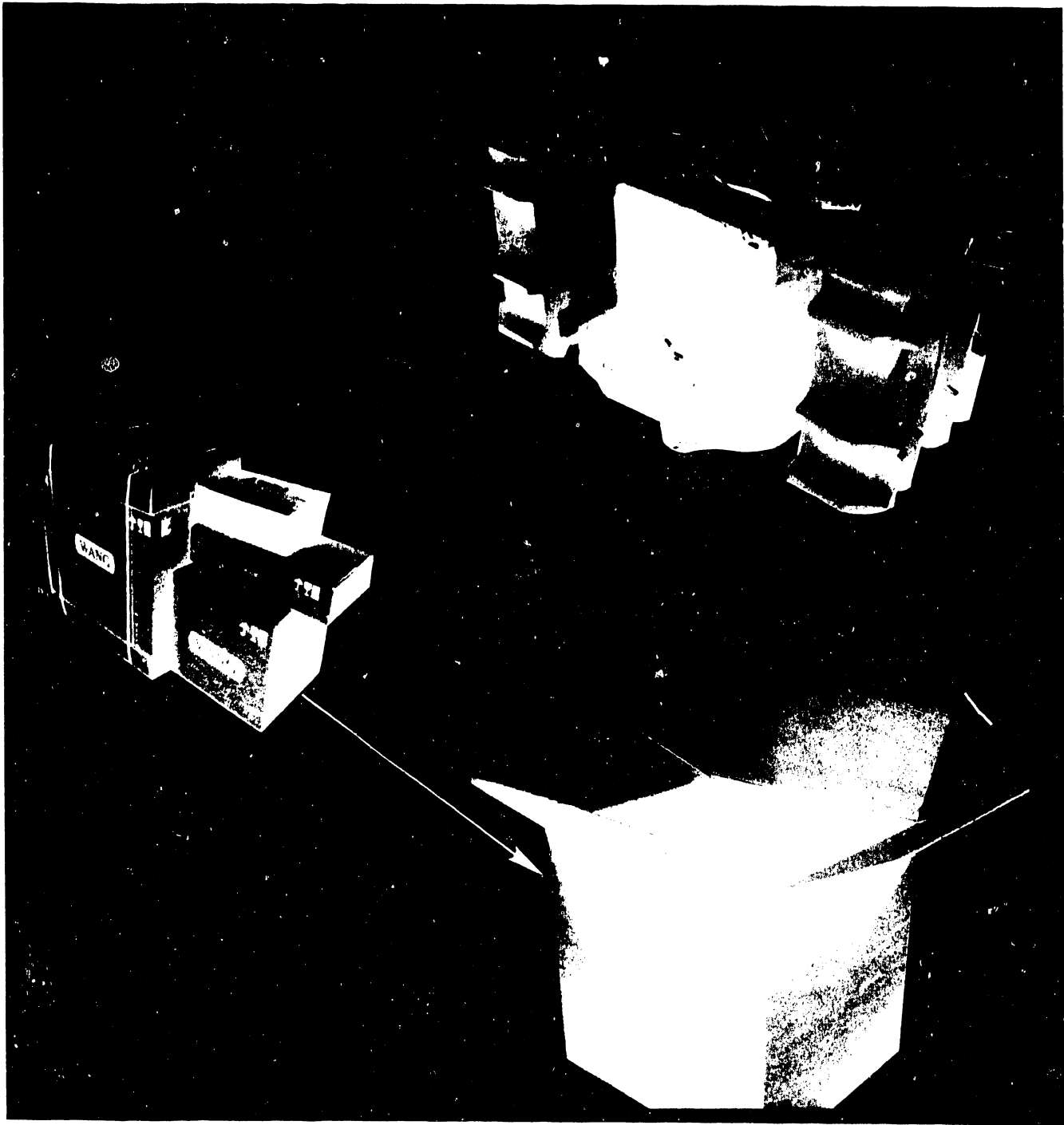

FIGURE 4-1 WANGWRITER UNPACKAGING (3 OF 6)

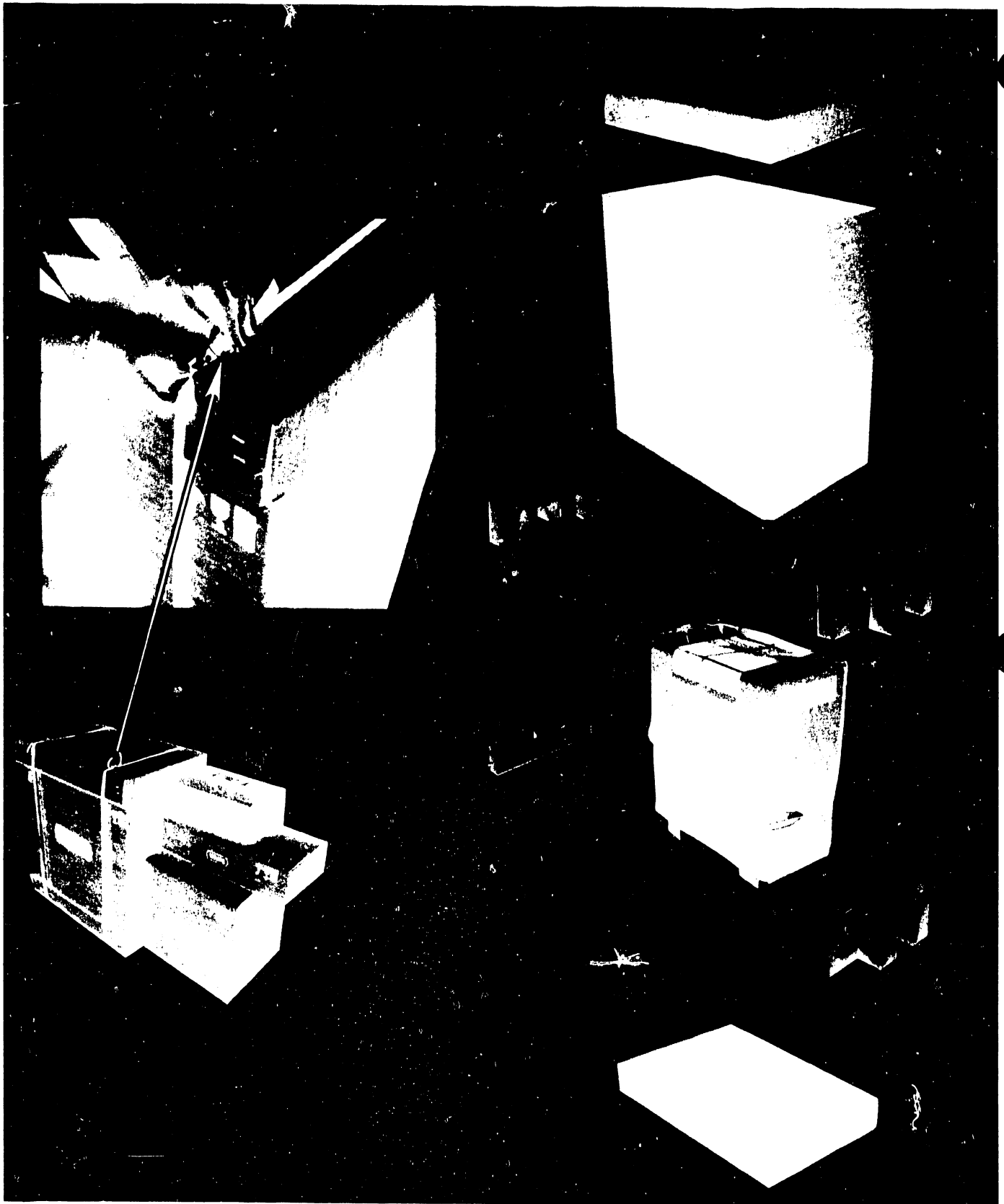

FIGURE 4-1 WANGWRITER UNPACKAGING (4 OF 6)

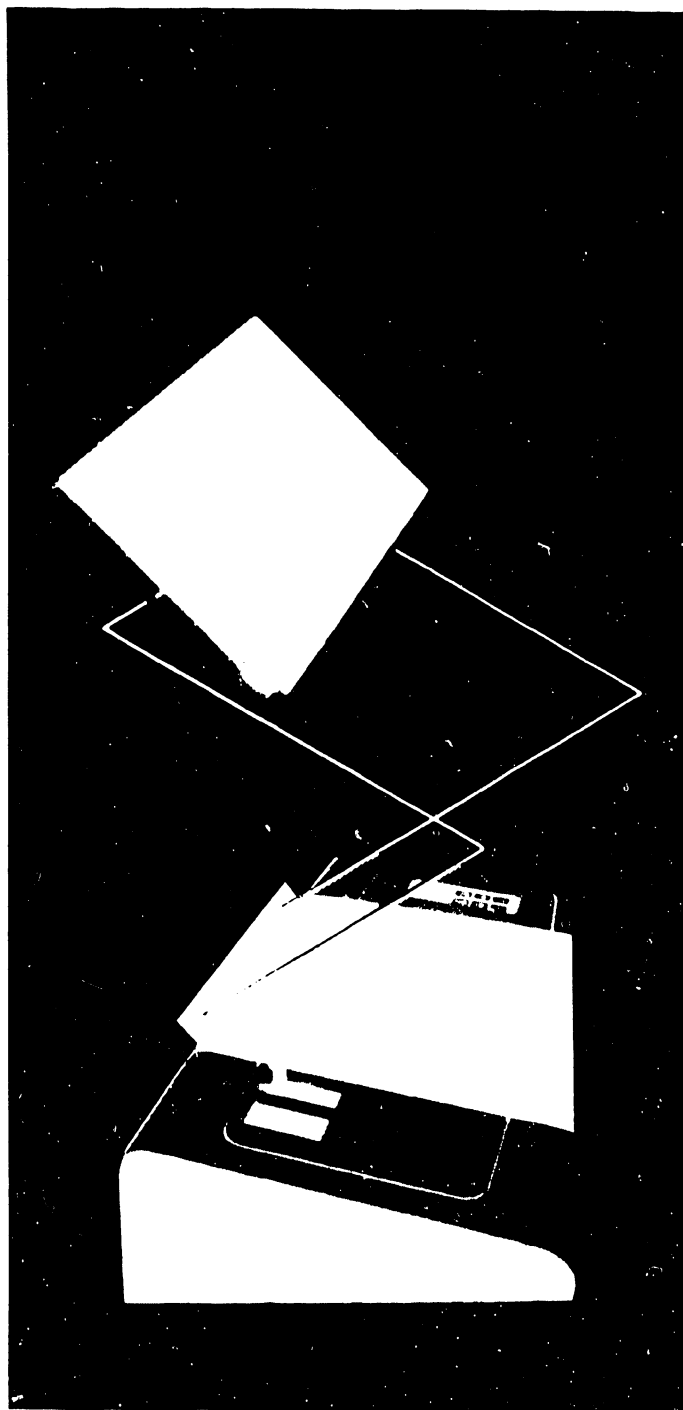

FIGURE 4-1 WANGWRITER UNPACKAGING (5 OF 6)

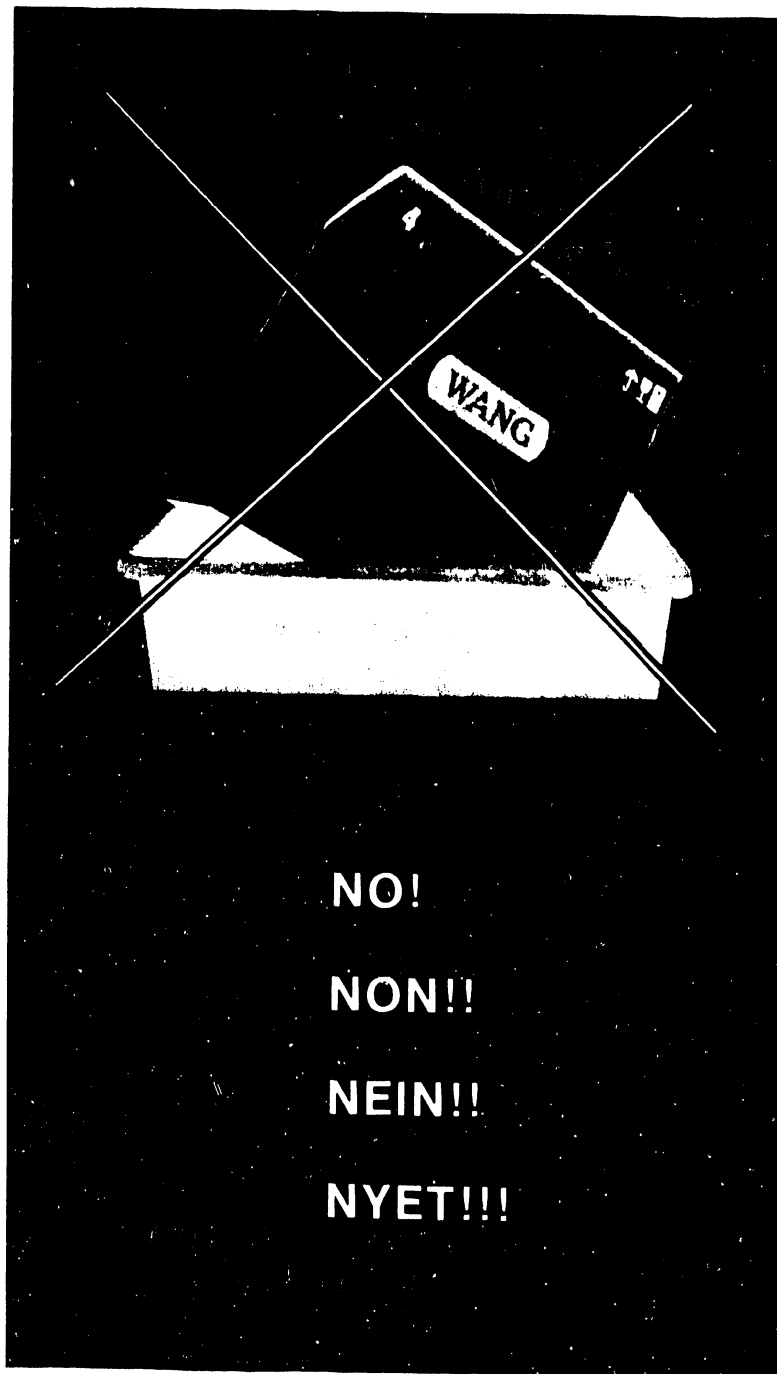

FIGURE 4-1 WANGWRITER UNPACKAGING (6 OF 6)

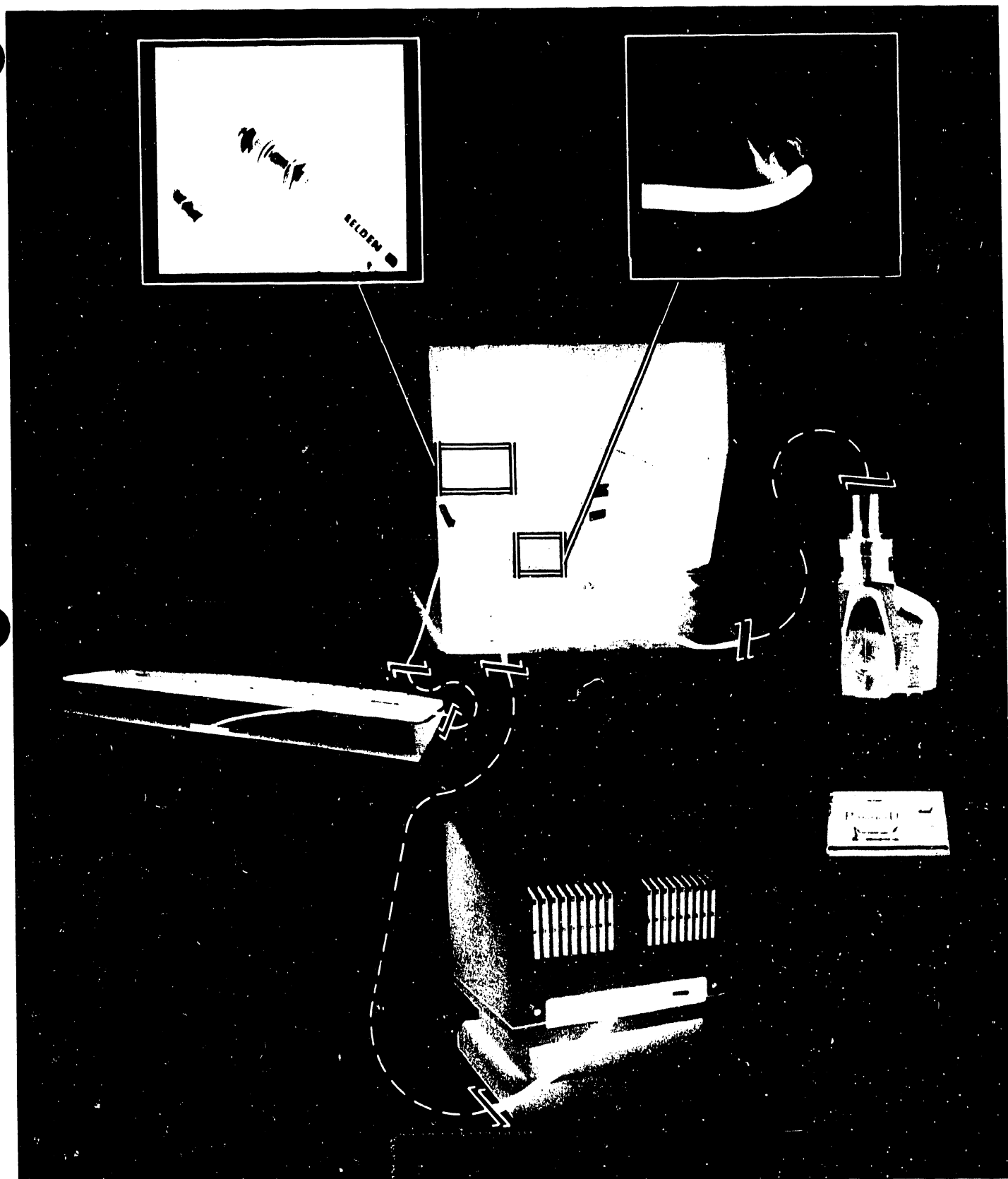

FIGURE 4 - 2 SYSTEM CABLING

MODEL 5503/5503A
SINGLE DISK DRIVE

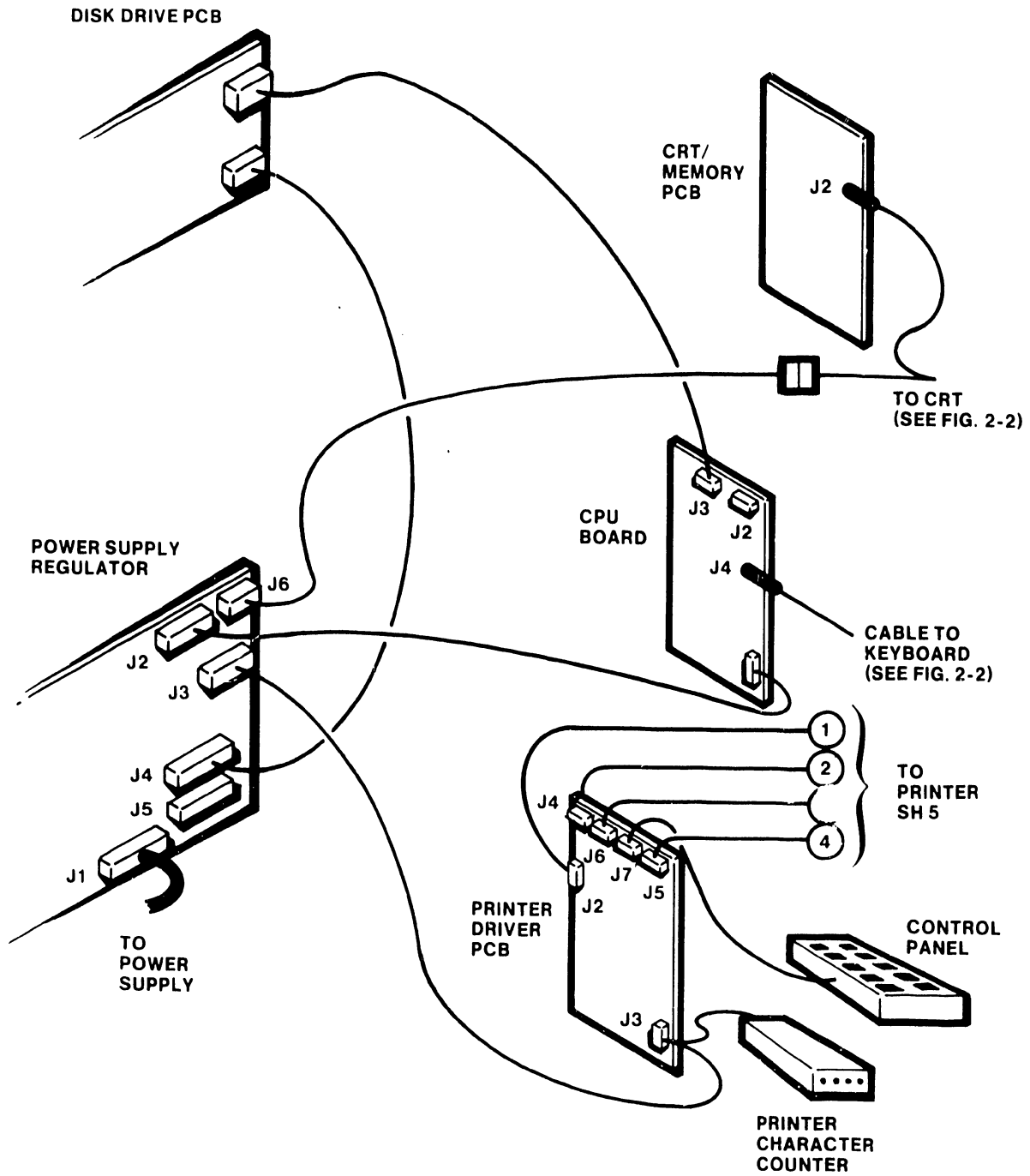

FIGURE 4-3 COMPONENT INTERCONNECTIONS (1 OF 5)

MODEL 5503D
DUAL DISK DRIVE

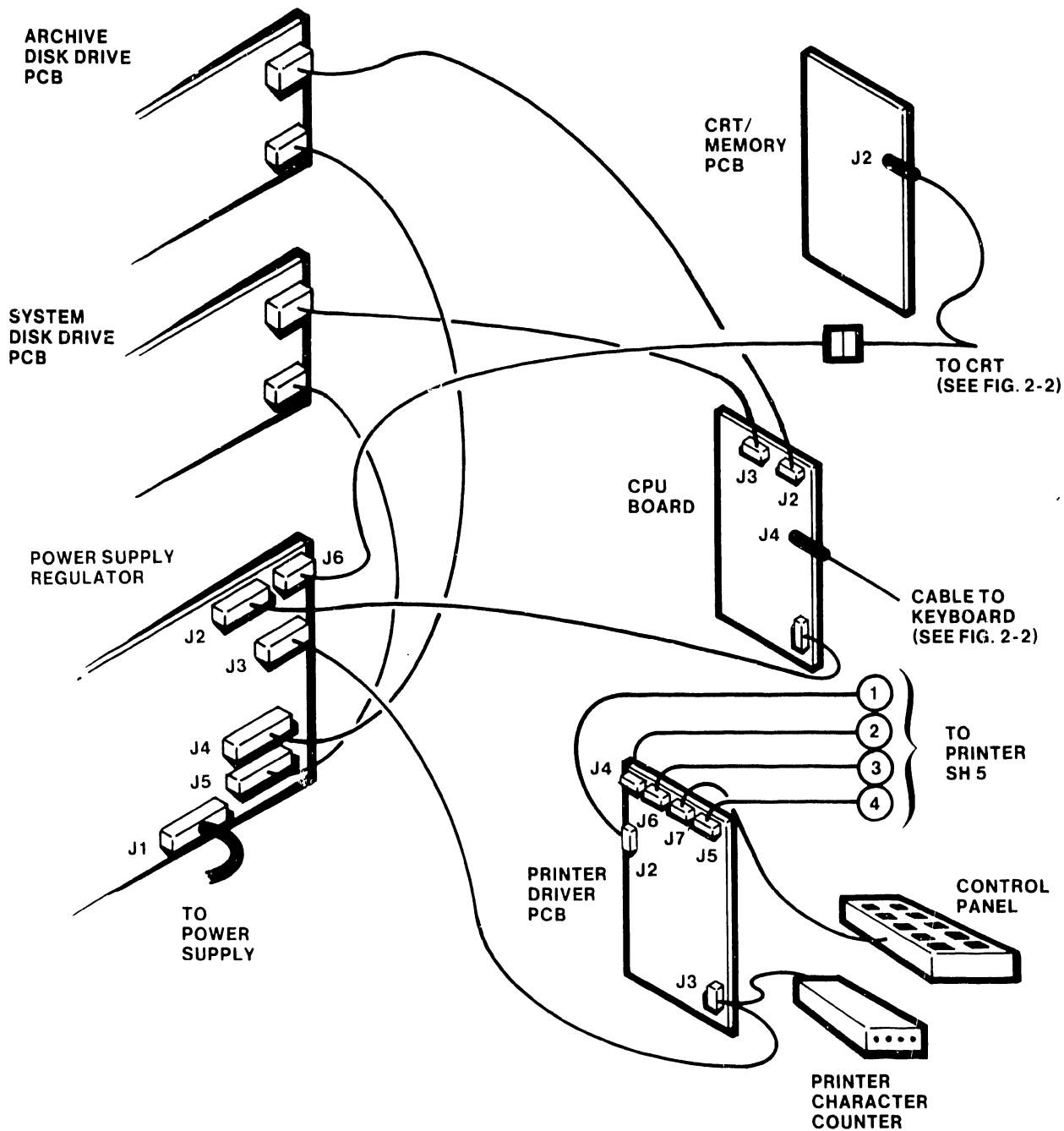

FIGURE 4-3 COMPONENT INTERCONNECTIONS (2 OF 5)

MODELS 5504S/5704S
SINGLE DISK DRIVE

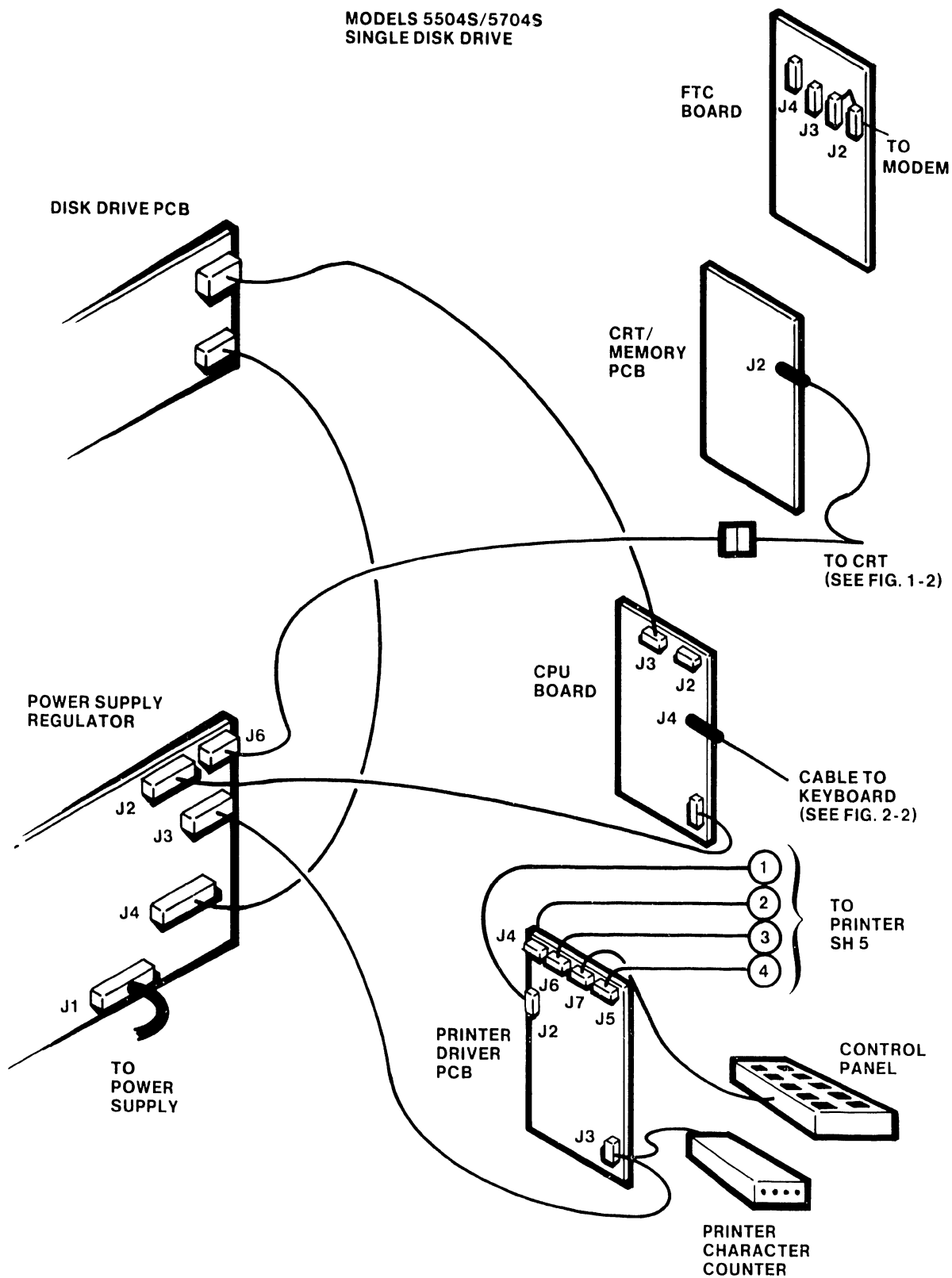

FIGURE 4-3 COMPONENT INTERCONNECTIONS (3 OF 5)

MODELS 5504D/5704D
DUAL DISK DRIVE

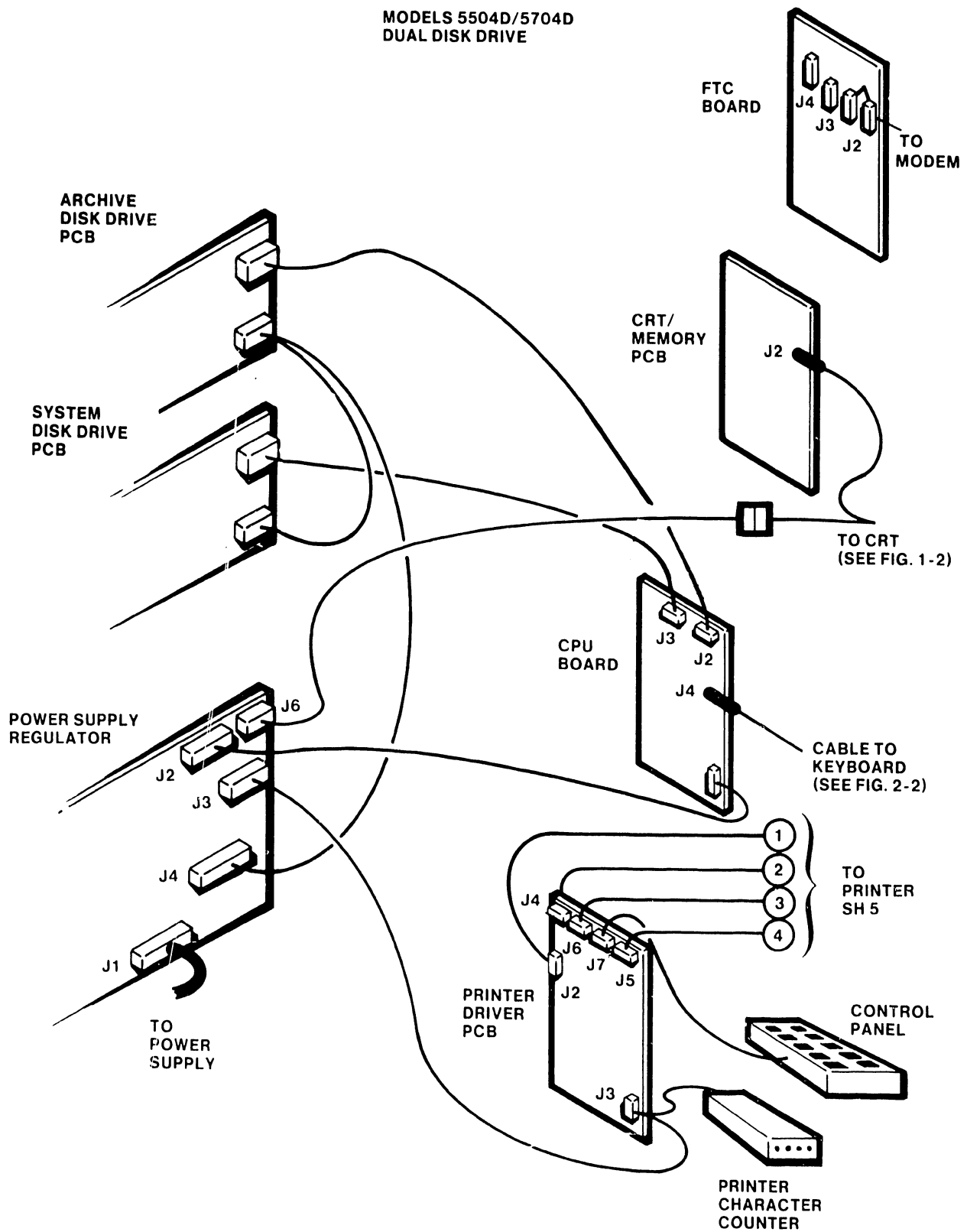

FIGURE 4-3 COMPONENT INTERCONNECTIONS (4 OF 5)

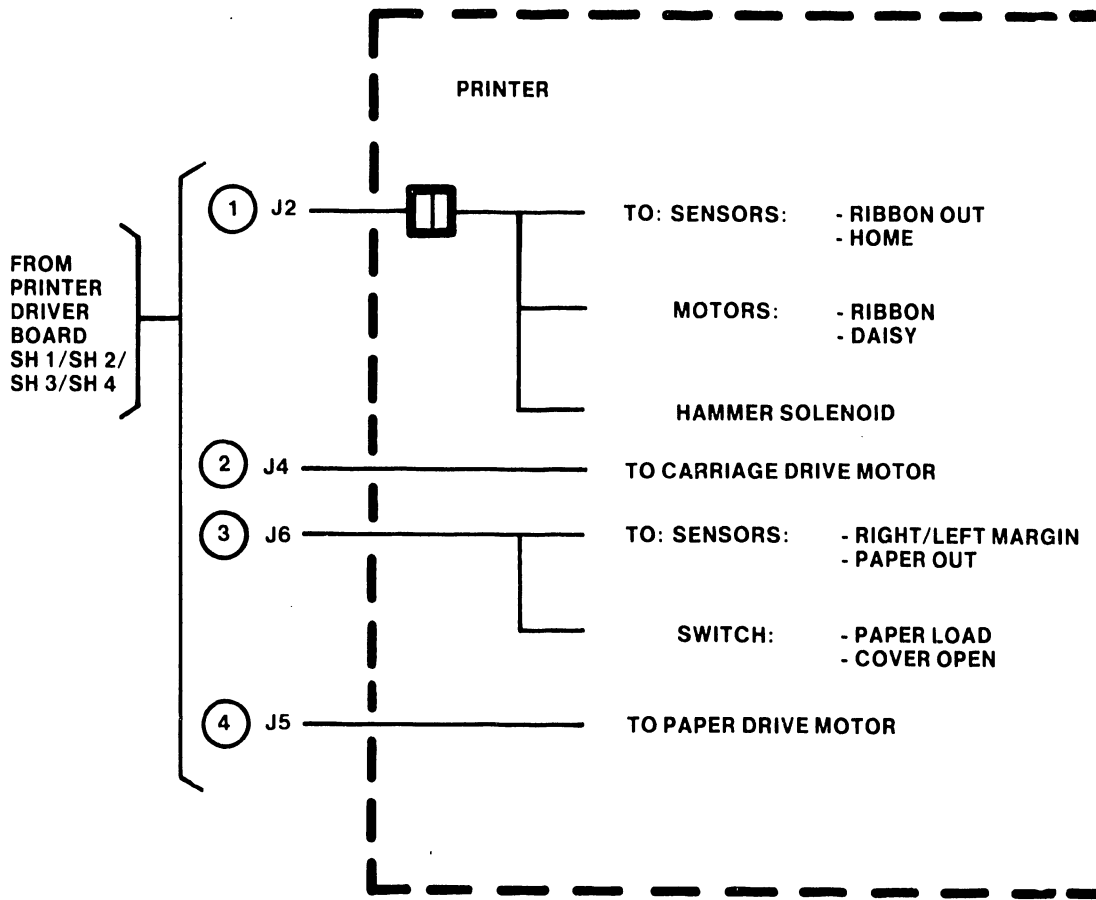
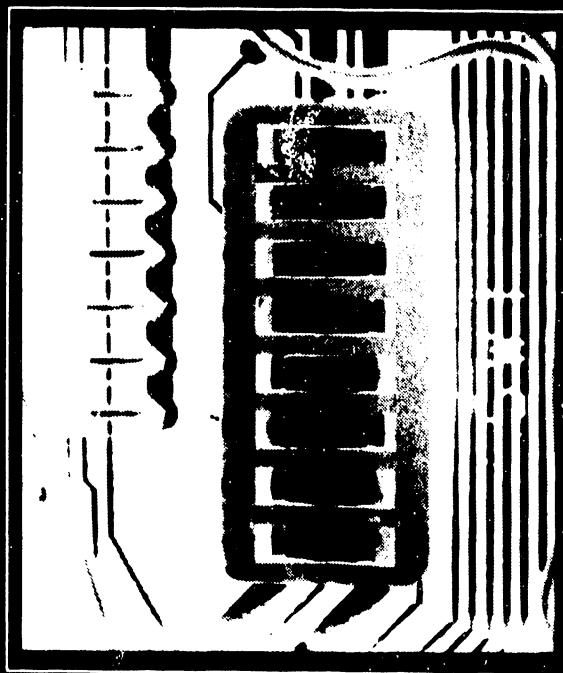
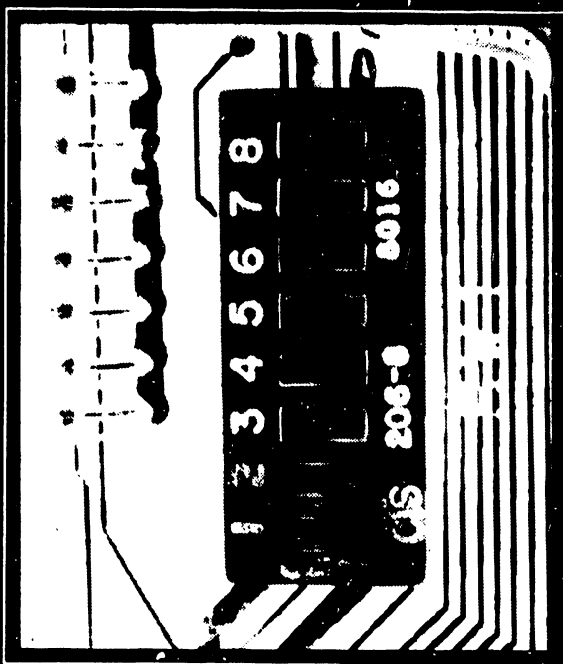

FIGURE 4-3 COMPONENT INTERCONNECTIONS (5 OF 5)



ROCKER-TYPE SWITCH



SLIDE-TYPE SWITCH

SWITCHES

4	TWO-DISK-DRIVE SYSTEM
2 & 1	96K MEMORY-5503
3 & 1	128K MEMORY-5504 5524

FIGURE 4-4 CPU BOARD OPTION-SWITCH SETTINGS

4.5 INSPECTION (continued)

Switch settings (continued)

Switches 1, 2, and 3 select memory size as follows:

<u>SW 1</u>	<u>SW 2</u>	<u>Sw 3</u>	<u>MEMORY SIZE</u>
ON	ON	N/A	96K (Not applicable to 5504)
ON	OFF	ON	128K (5504 only)

Reinstall the PC boards, and mate all connectors. Leave the side cover off pending power-up tests.

Remove the dummy diskette from the disk drive.

On 5503 models, verify that the power select switch (115VAC/220VAC) is at the correct setting; on 5504 models, select voltage by making appropriate connections on the terminal board inside the power supply above the fuse (see following sketch). The 5503 models will operate at either 50 or 60 Hz; Model 5504/5524 requires a power supply designed specifically for either 50 or 60 Hz.

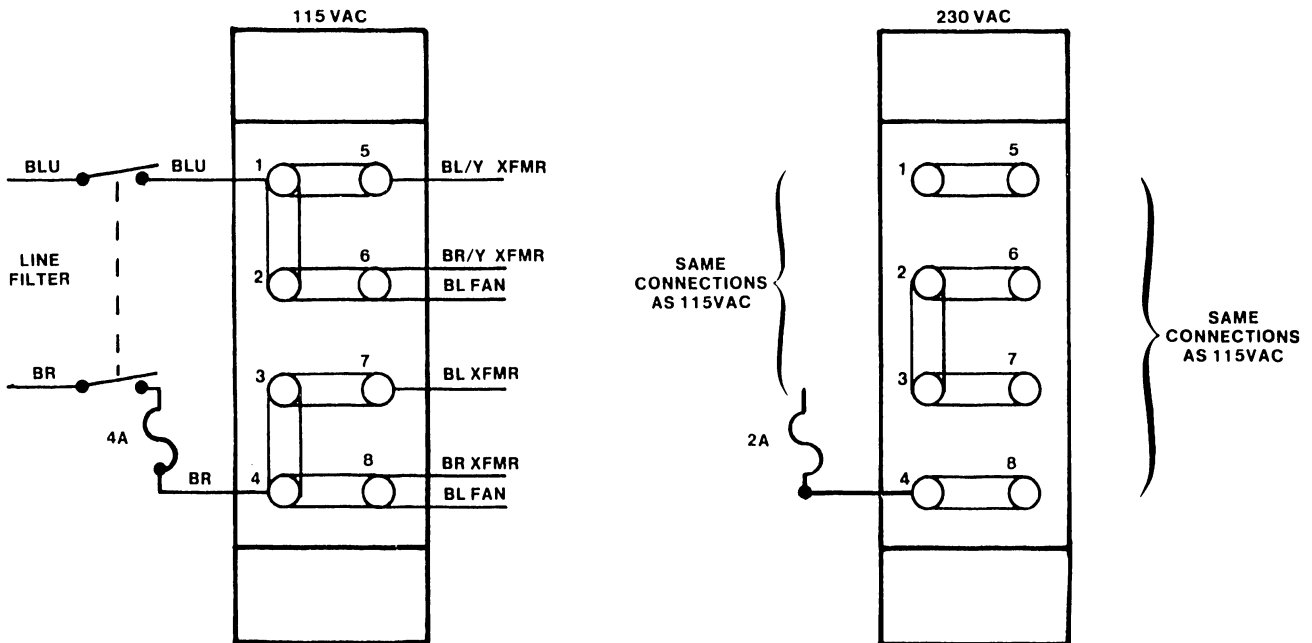

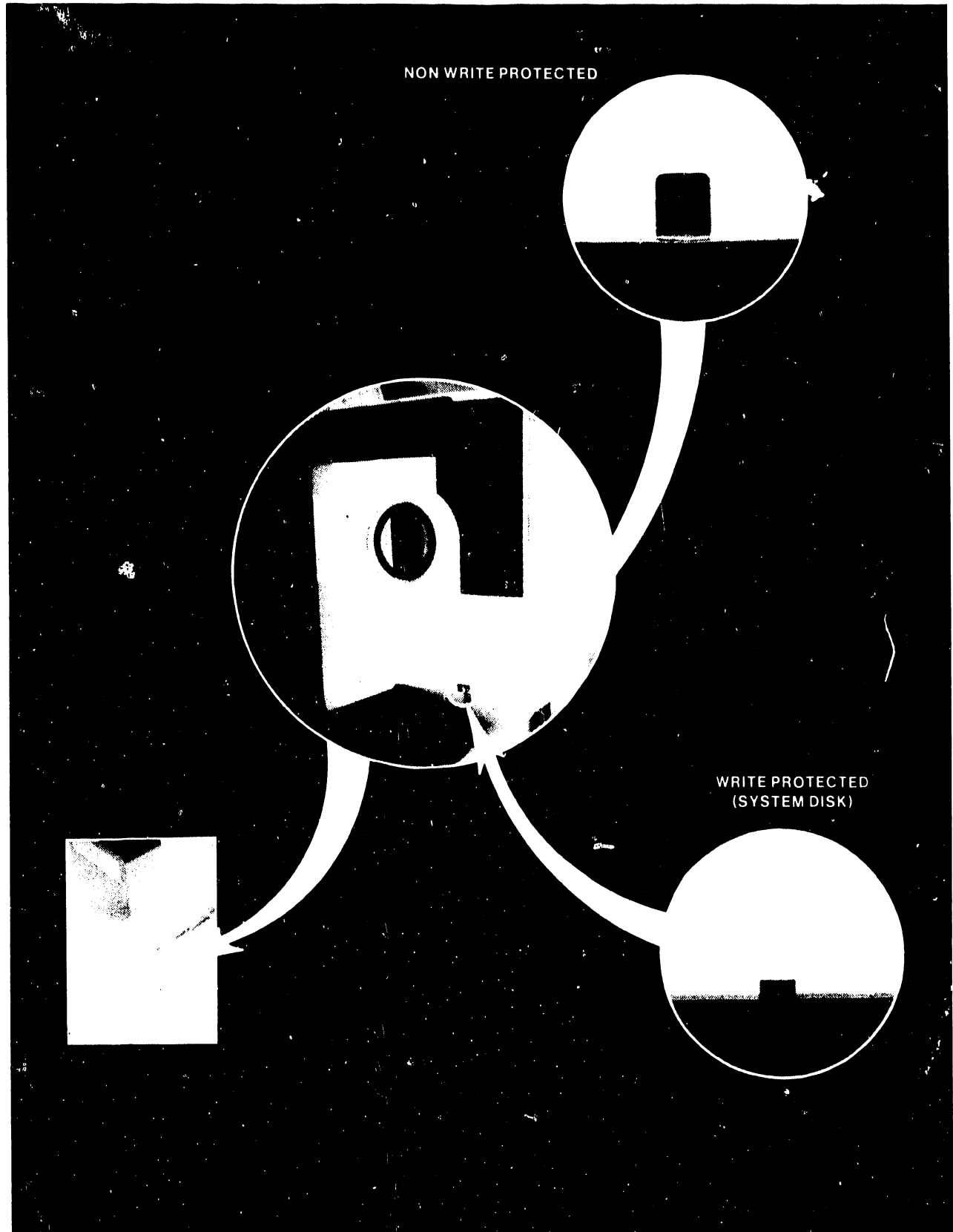

FIGURE 4-5 SYSTEM DISK INSERTION

4.6 INITIAL TURN-ON/POWER-UP DIAGNOSTIC

1. Remove system diskette from the paper dust jacket. Check that the write-protect slot is not covered with a tab. The protective shield should have arrows indicating direction of diskette insertion. If no arrows, position write-protect slot at the bottom nearest the door (see Figure 4-5).

CAUTION

Be sure that the shipping (dummy) diskette has been removed from the disk drive.

2. Seat diskette in the drive slot; if there are two drives in the system, the system diskette always goes in the lower drive. Do not close the door, pending power turn-on.
3. Press "1" on the red power switch to turn the system ON, then close and lock the drive door within 10 seconds to prevent the system power-up diagnostic and bootstrap routine from timing out (Model 5504 and new Model 5503 power-up PROMs will loop, waiting for the disk drive to have a diskette inserted and for the door to be closed).

The seven-segment LED at the rear of the console will indicate successful completion of the power-up diagnostic by displaying:

- F, if the loaded software is CP/M.
 - a continuous cycling through the segments, if the loaded software is for word processing.
4. Check system operating condition in accordance with Figure 4-6. Should the seven-segment LED (back of console) indicate a component error:
 - Check and reseal power and signal connectors.
 - Replace component in accordance with indications listed in Table 4-1.

Table 4-1 Error Code Indications (in order
of test sequence)

<u>ERROR CODE</u>	<u>PCA</u>	<u>FIELD REPLACEABLE UNIT</u>
.8	CPU 210-7777A	Z80 (.8 = the power up value of the seven-segment display)
4	CPU 210-7777A	PROM
6	CPU	Floppy disk controller
0	CRT/MEM 210-7775A	VTAC
7	CPU	CPU UART, or PIO/keyboard
1	CRT/MEM	Main memory
2	CRT/MEM	CRT memory
d	Parallel Interface	Parallel Interface Board 210-7978
E	Printer/ Driver PC Board 210-7776A	PIO
9	CPU	CTC
A	CPU	FDC, disk drive, or disk drive cable
3		Disk drive, or system diskette (failure to IPL)
F	None	Power-up Successfully completed

5. Should voltage adjustments be necessary, adjust potentiometers R2/R1 for +5/+12 (see Chapter 5 instructions).
6. Following the completion of the initial turn-on and the power-up diagnostic, reinstall console side cover.

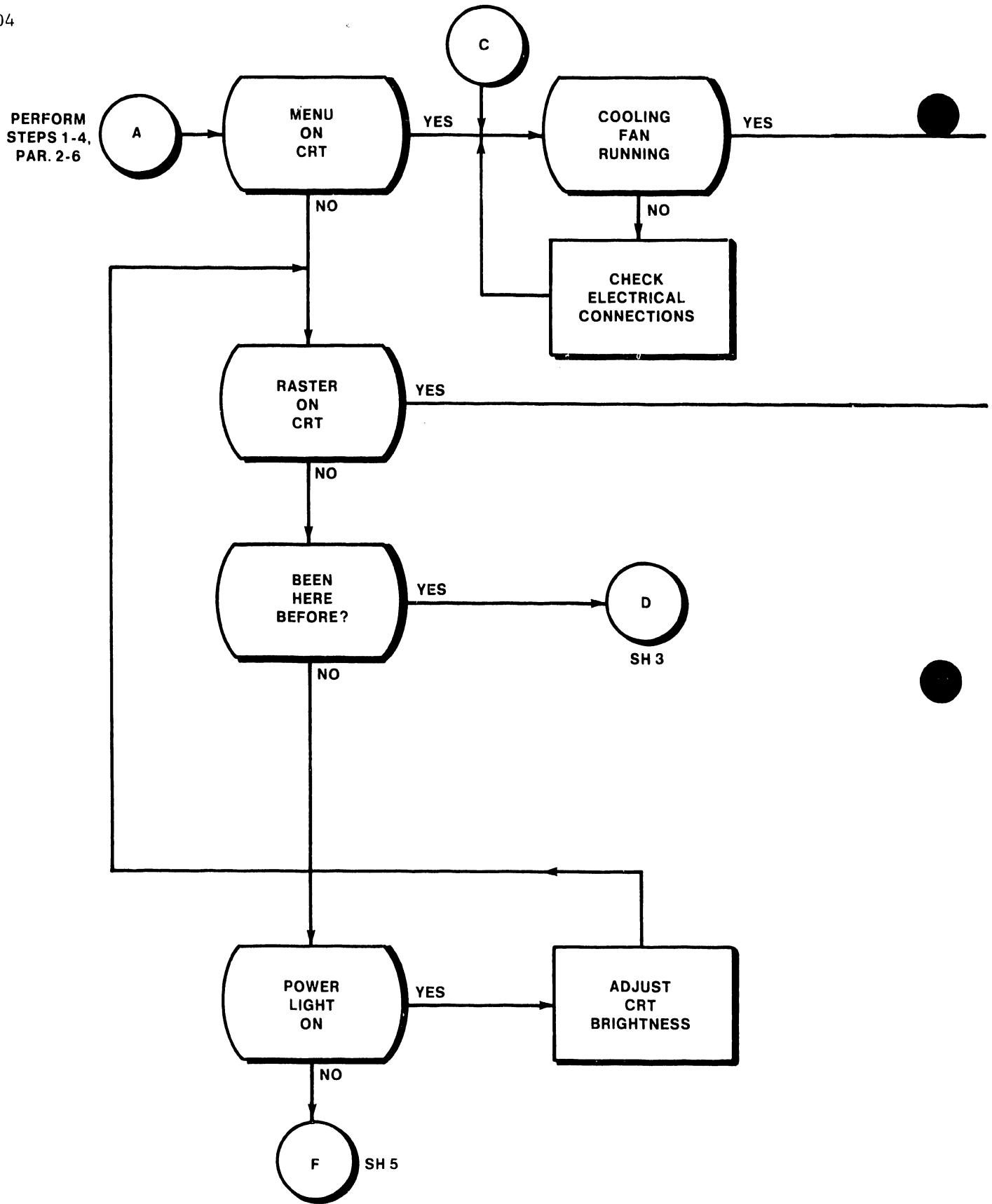

FIGURE 4-6 POWER-UP CHECKOUT (1 OF 5)

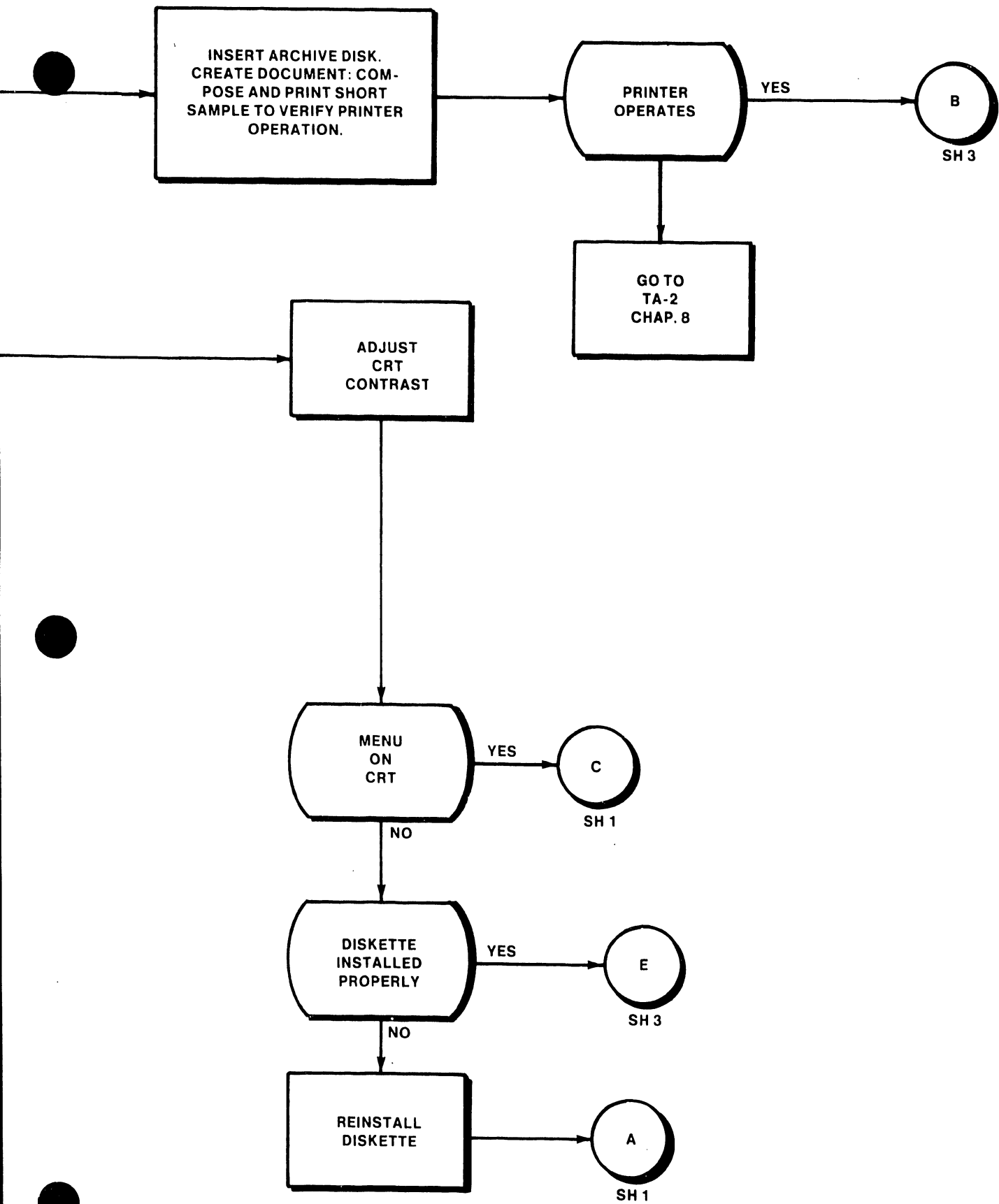

FIGURE 4-6 POWER-UP CHECKOUT (2 OF 5)

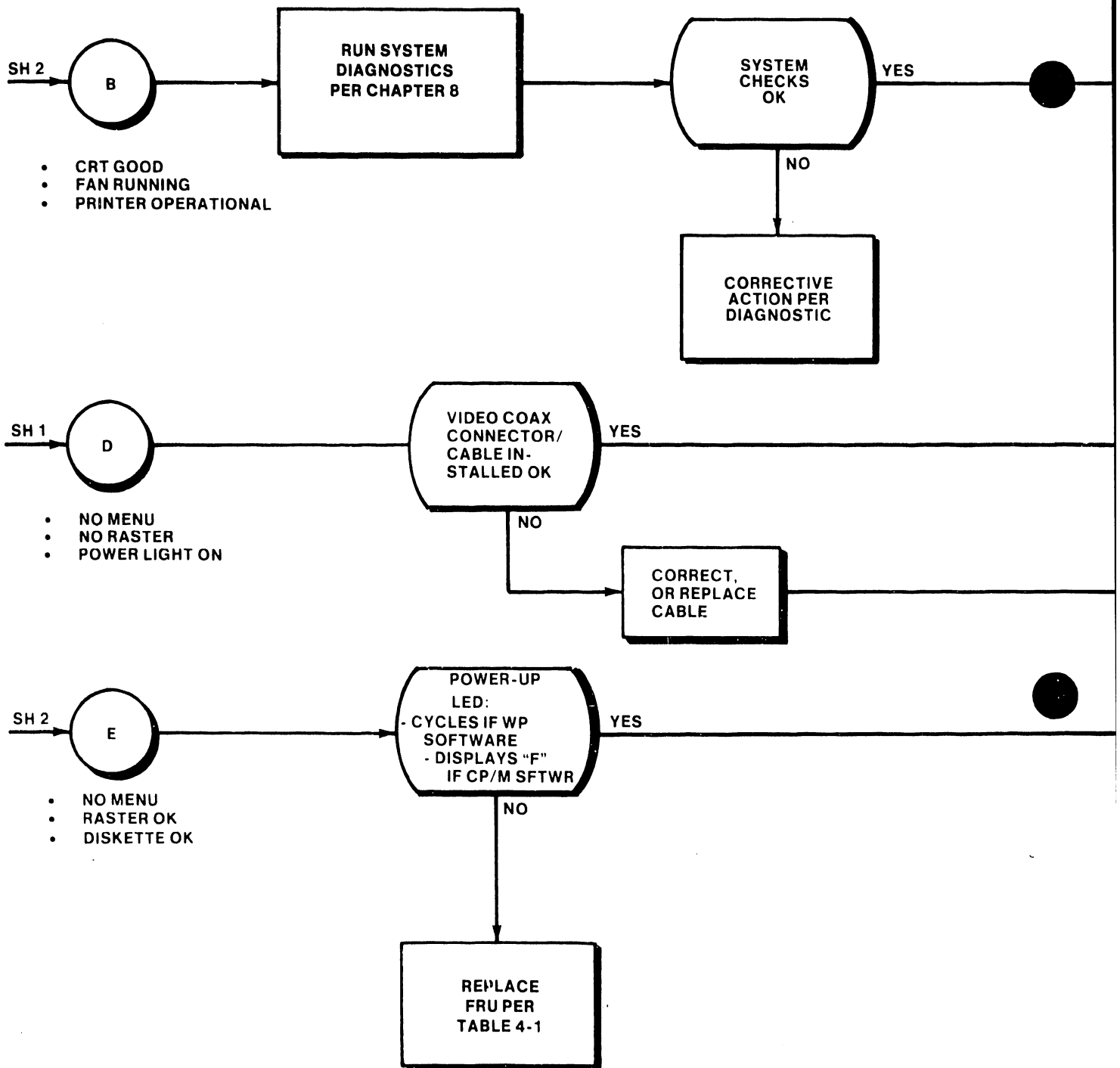

FIGURE 4-6 POWER-UP CHECKOUT (3 OF 5)

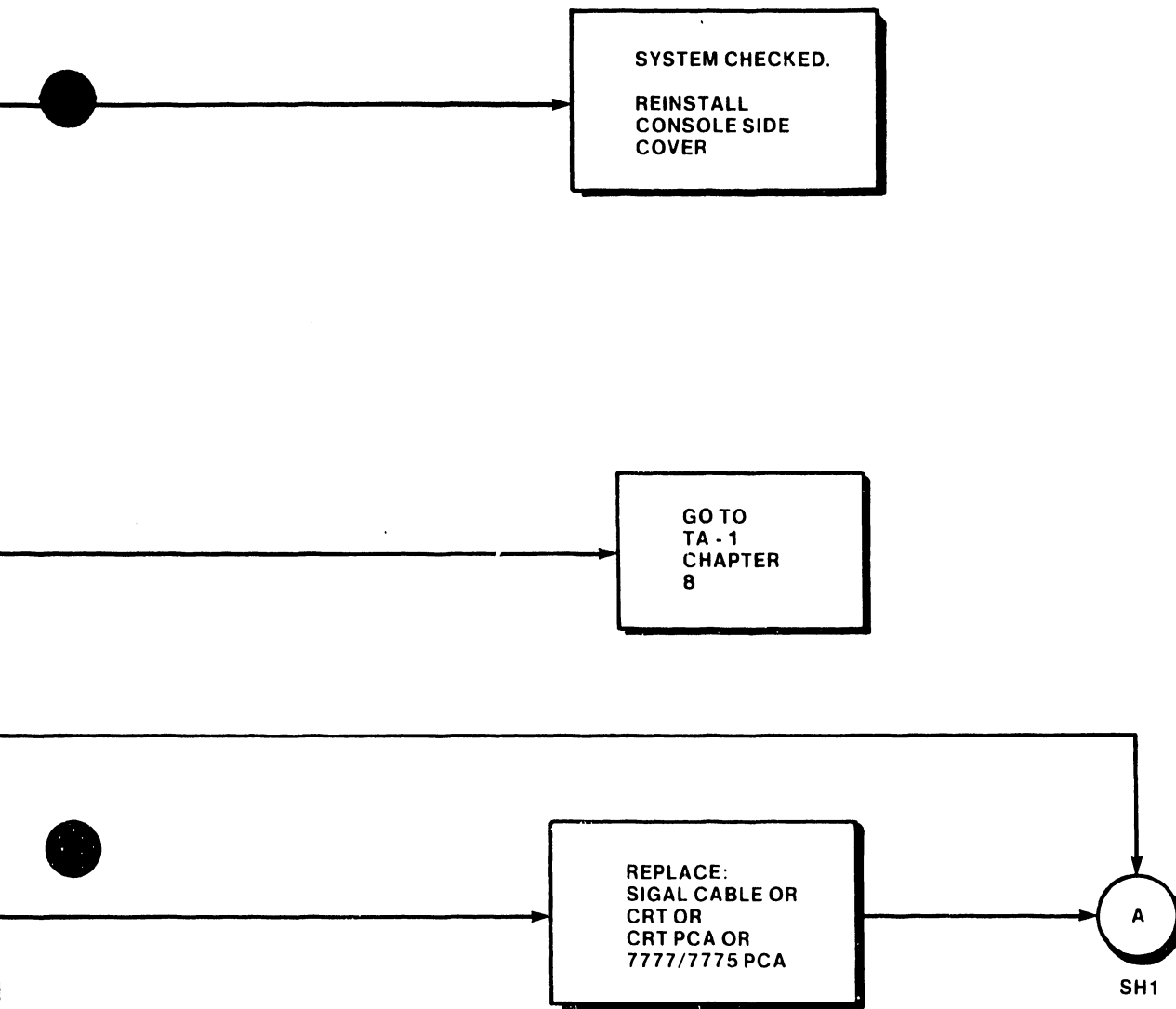

FIGURE 4-6 POWER-UP CHECKOUT (4 OF 5)

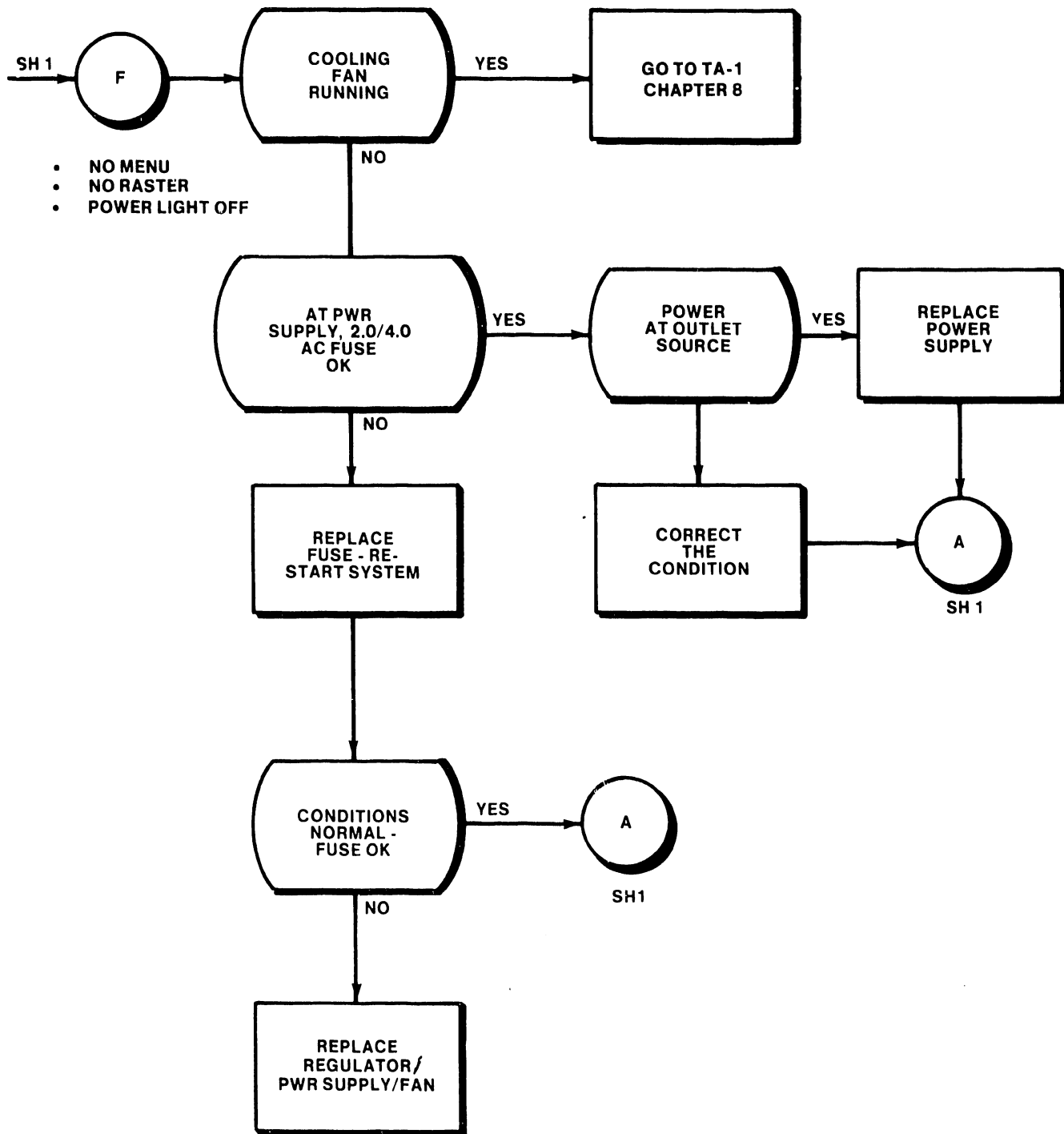

FIGURE 4-6 POWER-UP CHECKOUT (5 OF 5)

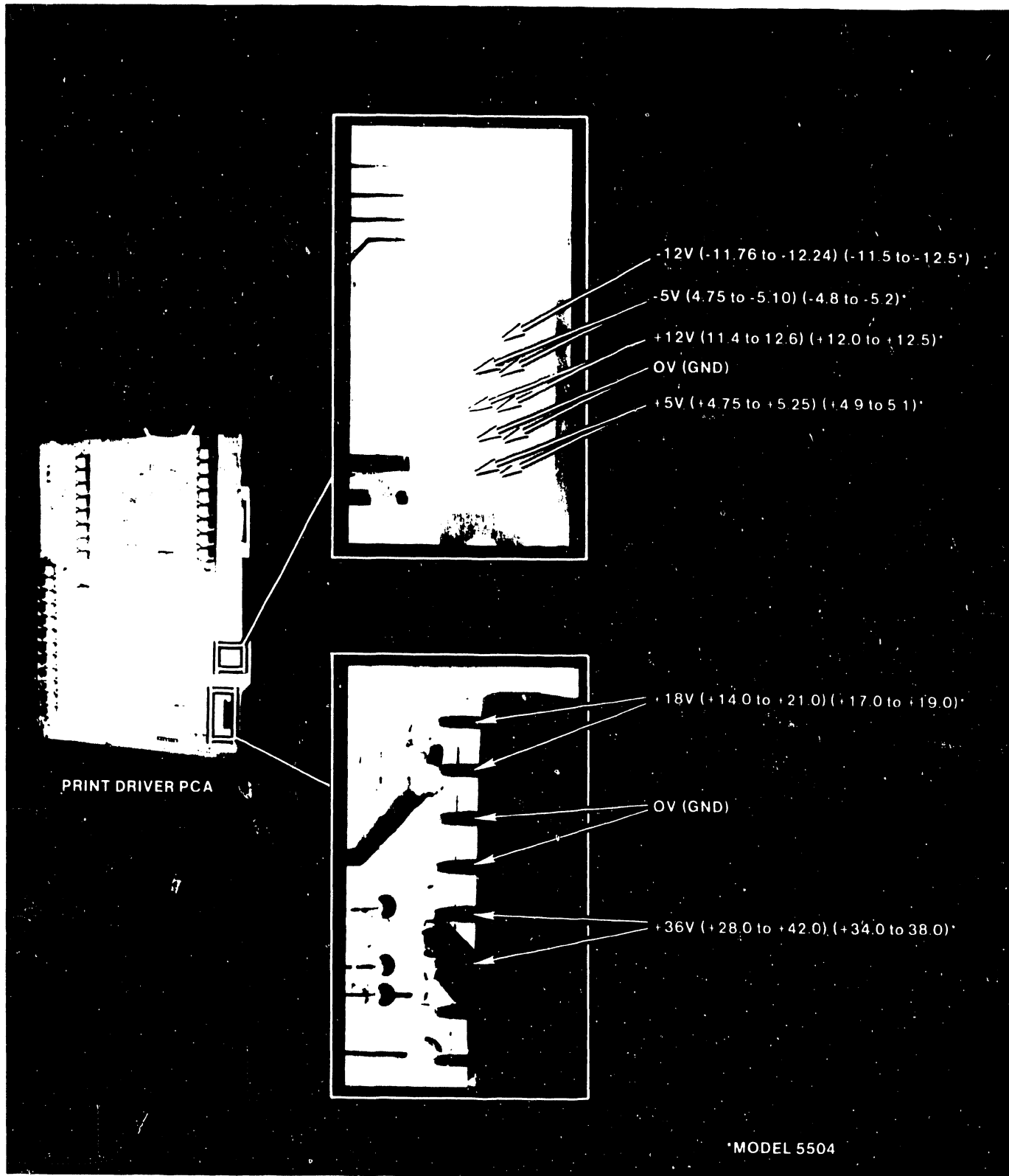

FIGURE 4-7 POWER SUPPLY VOLTAGES

4.7 SINGLE-SHEET FEEDER INSTALLATION AND CHECKOUT

Refer to Appendix section for retrofit procedures should such be necessary for single sheet feeder installation and operation.

4.7.1 INSTALLATION (Figures 4-8 and 4-9)

1. Remove any paper from the printer platen; close top cover.
2. Open sliding door located next to the load lever (slide toward front of console.
3. Align feeder with the printer, and lower until the locking latch slides into the opening to the left of the load lever. Fit slotted section (right end of feeder) over the plastic hinge located between the cover rear and the case. With the feeder fully seated, the latch should catch and secure the feeder to the printer.
4. For accessing the printer head, raise printer cover until the cover release spring (see Figure 3-1) latches the cover in raised position.

CAUTION

Before lowering the printer cover from raised position, depress cover release spring.

5. Install static shield on the feed tray (see Figure 4-9).
 - a. Loosen the two knurled thumbscrews, and slide eliminator cutouts between the paper tray and the tray mounting plate.
 - b. Tighten thumbscrews.

4.7.2 CHECKOUT

4.7.2.1 Paper Cartridge Installation

1. With the paper cartridge outside the feeder, fill cartridge with the appropriate size and grade of paper (specified on the front of each paper cartridge). Ensure that the paper goes between the front and back paper catches. Fan paper before loading.
2. On feeder, turn LOAD/RUN knob to LOAD.
3. Lower cartridge into the feeder, sliding cartridge track along the cartridge guide on the feeder interior surface.
4. Turn LOAD/RUN knob to RUN.

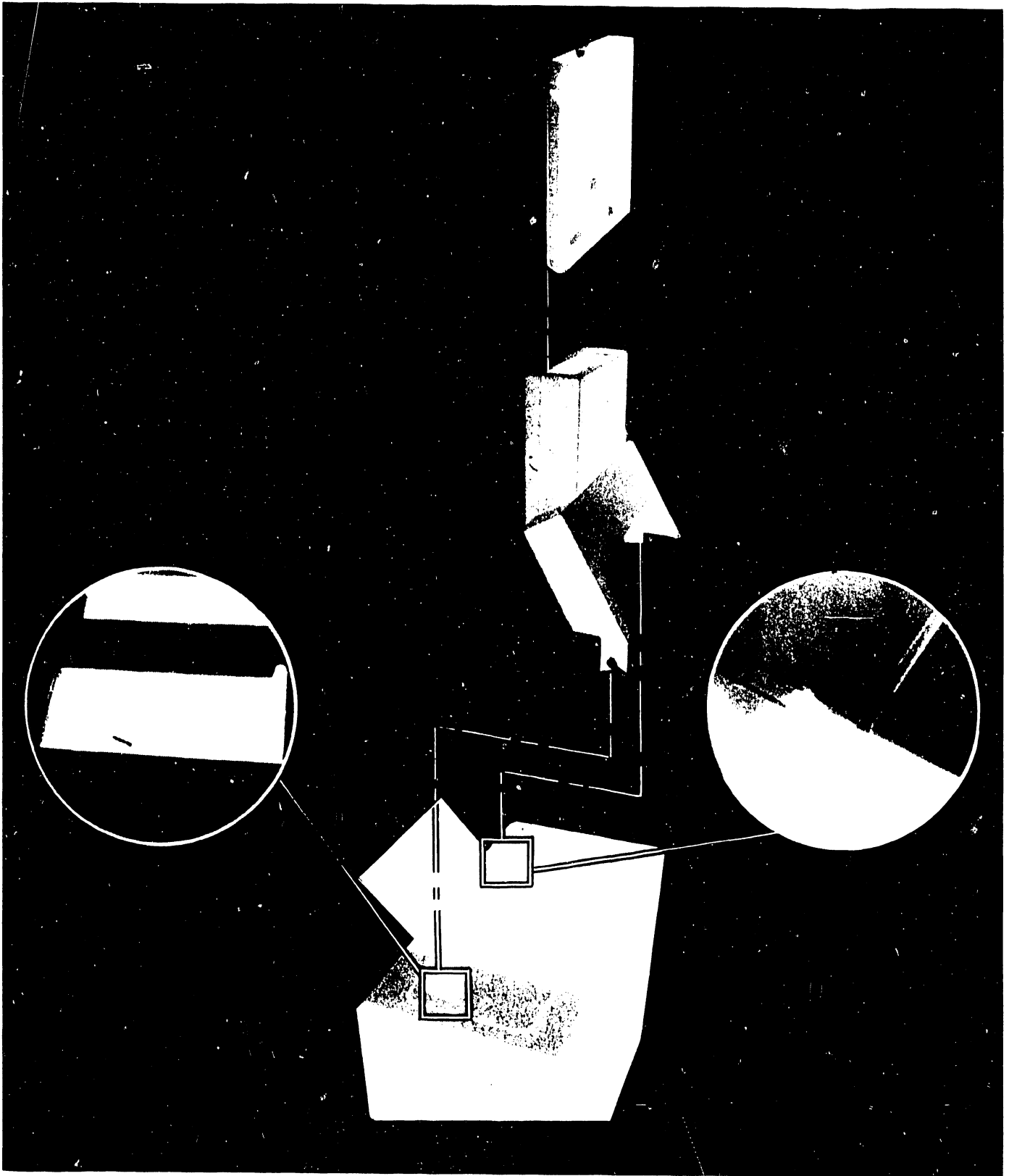

FIGURE 4-8 SINGLE SHEET FEEDER INSTALLATION

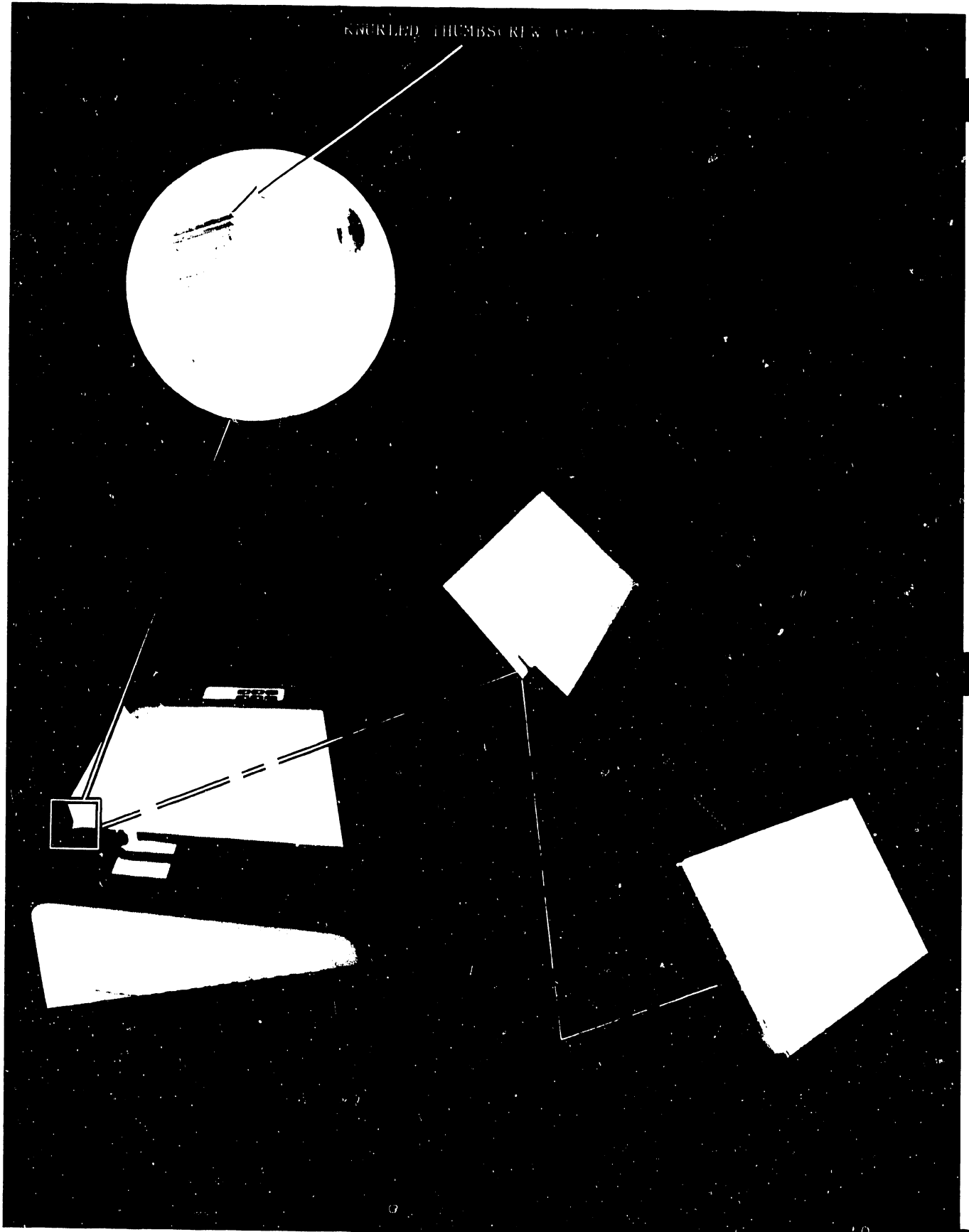

FIGURE 4-9 STATIC ELIMINATOR INSTALLATION

4.7.2.2 Automatic Feed

1. Start Wangwriter operation in accordance with system operating procedures.
2. Select Print Document from the start-up menu; select Feeder from the paper-load field. Press EXECUTE.
3. On the printer console, press SELECT to initiate operation. The platen should receive a sheet from the feeder, and should pull the sheet into printing position. Printing should start. When printing is finished, the printer automatically ejects the page downward.
4. To eject a page prior to its completion, press SELECT (to deselect the printer), then press TOP OF PAGE control on the printer console. The printer should eject the unfinished page, and the feeder should move another sheet into print position. Press SELECT to restart the printing of the page.

4.7.2.3 Printer Skew Check with Automatic Feed

Create document (see Operation, Chapter 3), and print several pages with the feeder in use. Verify that the paper skew is within tolerance. As measured from the top of the sheet to the bottom of the character, the difference between columns 1 and 80 should not exceed 0.050 inch.

If there is skew, perform the following checks to determine the cause.

1. Remove the feeder.
2. Select the skew test document, and print using Manual Mode. Load a sheet of paper by pulling the load arm, holding it until the load cycle is complete (platen stops) as indicated in step 8b (RETROFIT PROCEDURE). Be sure that the paper is loaded with the edge at least 1/16 inch from the edge of the paper tray.
3. Print several sheets, and check for skew. When this method is used, unequal tension of the paper guide rollers may be the cause of any paper skew, should such occur.

Should skew occur, first check that paper guide locator pins (two) that fit through the printer frame are free so that the guide is not jammed at either end. If locator pins check OK, check roller tension at the entrance rollers as described in step 8a (RETROFIT PROCEDURE).

An absence of paper skew when Manual Load is used eliminates the paper guide as a possible cause of paper skew.

4. Select skew-test document, and print using Sheet Feeder mode of paper load.

Insert a sheet of paper into the platen evenly, 1/16 inch from the paper tray left edge, and press SELECT on the printer. (It is important that the sheet not contact the paper tray left edge as the tray will tend to guide the paper straight despite roller tension problems.) The sheet should now feed automatically into print position and begin printing.

Repeat the foregoing operation with several sheets. Any skew now occurring results from the bail rollers not catching the top edge of the paper evenly. This causes the paper to buckle slightly more on one side than on the other.

Verify the following:

- Bail rollers are positioned properly and are the same diameter.
- Right and left rollers have equal pressure when turned by hand. If uneven, check that shaft is not bent.
- Card guide evenly spaced on both right and left sides relative to the platen, and adjusted high enough. Bend card guide bracket to get even spacing on both sides. If the card guide is bent in too close to the platen, the paper will catch, and skew the paper when it is ejected down into the stacker.

Check card-guide-to-platen spacing:

- Fold sheet of 20-lb paper twice to create four-paper thickness.
- Lift bail up, pull print head forward (away from the platen), and insert folded paper under the left side of the card guide. Re-seat the print head so that it latches down.
- Pull on the paper. The fit should be snug.
- Repeat test for the right side of the card guide. The tension should match that of the left side.

If adjustment of the card guide mounting bracket is necessary, first verify that the print-wheel-to-platen adjustment is correct as indicated in Chapter 5 of the Wangwriter Maintenance Manual. If the head is positioned so that the damper plate mounting bracket right and left sides are not the same distance from the platen, pressure will not be applied evenly to the card guide left and right sides.

4.8 FOREGROUND TELECOMMUNICATIONS (FTC) INSTALLATION

This paragraph provides installation and checkout for the optional 210-7771 FTC board used on Wangwriter Models 5304/5704, via the following topics:

- Hardware/Software packages
- Typical Communications Configurations
- Installation
- Diagnostic/Verification Tests
- Operating status checks

4.8.1 HARDWARE/SOFTWARE PACKAGES

The FTC is to be installed and tested as follows (Refer to Wangwriter Teletypewriter Emulation USER GUIDE 700-7165):

Hardware: Model number W4-FTC

Modem Interface Protocols

<u>INTERFACE</u>	<u>CEI#</u>	<u>FTC ASSEMBLY</u>	<u>FTC BOARD</u>	<u>CONNECTOR#</u>
RS232	177-9458	212-2200	210-7771-1A	220-3218
X.21	not assigned	212-2201	210-7771-3A	220-3217
RS449	not assigned	212-2202	210-7771-2A	220-3219

- RS-232 Loopback Connector WL 420-1040
- RS-449 Loopback Connector WL 270-3193
- X.21 Loopback Connector WL 421-0010

Software:

- W4-FTC-TTE (Teletype Emulation) 703-2268
- W4-FTC-Batch (2780/3780 Emulation)
- W4-FTC-2236 (2200/2236DE Interactive Terminal Emulation)

4.8.1 HARDWARE/SOFTWARE PACKAGES (continued)

Diagnostics: Wangwriter In-System Diagnostic Rev 22be WLI No.
732-8001 R1

4.8.2 TYPICAL COMMUNICATIONS CONFIGURATIONS

A user of the FTC may specify the software and modem interface protocols desired; however, the following illustrations apply only to the RS232 modem interface. The illustrations show typical configurations for each software protocol:

- W4-FTC-TTE - Figure 4-10
- W4-FTC-2236 - Figure 4-11
- W4-FTC-BATCH - Figure 4-12

Tables 4-2 and 4-3 list the cable variables for respectively the modem interface cables and the direct connection cables.

Table 4-2

Modem Interface Cables

	<u>RS232</u>	<u>X.21</u>	<u>RS449</u>
12'	220-0113 (standard)	220-0274 (standard)	-
20'	-	-	220-0248 (standard)
25'	120-0219 (optional)	120-2326-01 (optional)	120-2325-01 (optional)
50'	120-0230 "	120-2326-02 "	120-2325-02 "
100'	-	120-2326-03 "	120-2325-03 "
250'	-	120-2326-04 "	120-2325-04 "
500'	-	120-2326-05 "	120-2325-05 "
750'	-	120-2326-06 "	120-2325-06 "
1000'	-	120-2326-07 "	120-2325-07 "

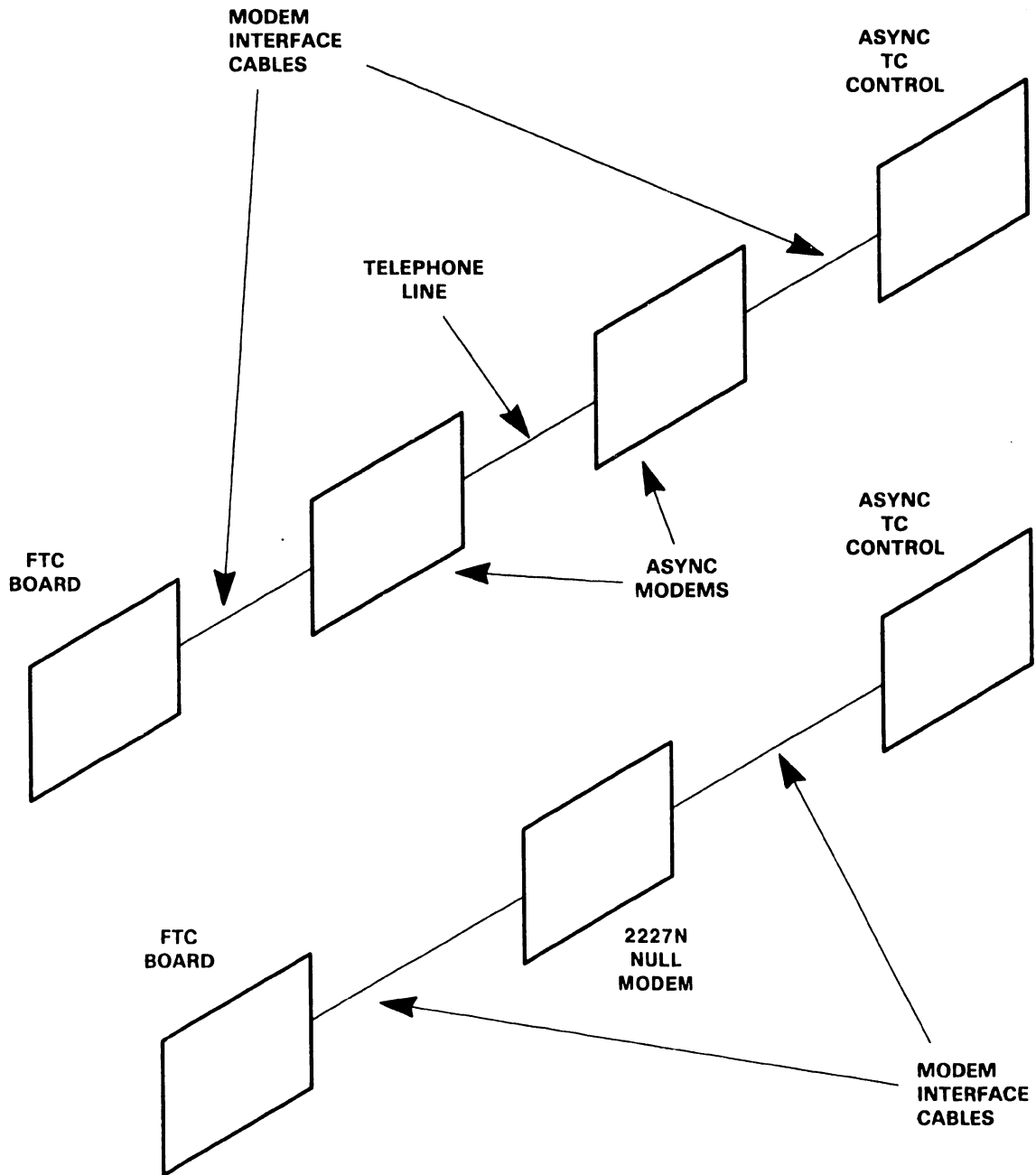

FIGURE 4-10 TYPICAL COMMUNICATIONS CONFIGURATION - W4-FTC-TTE PROTOCOL

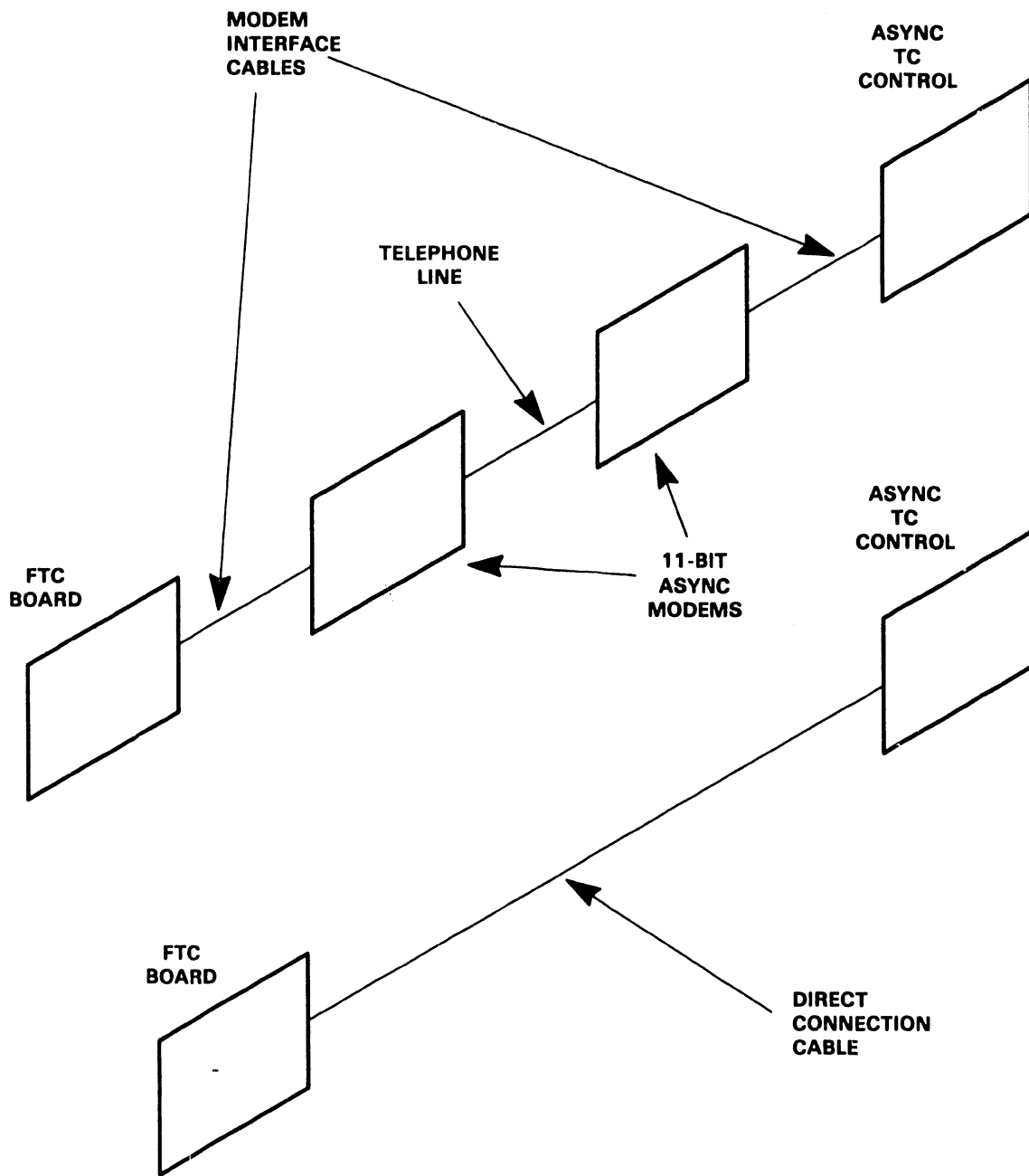

FIGURE 4-11 TYPICAL COMMUNICATIONS CONFIGURATIONS - W4-FTC-2236 PROTOCOL

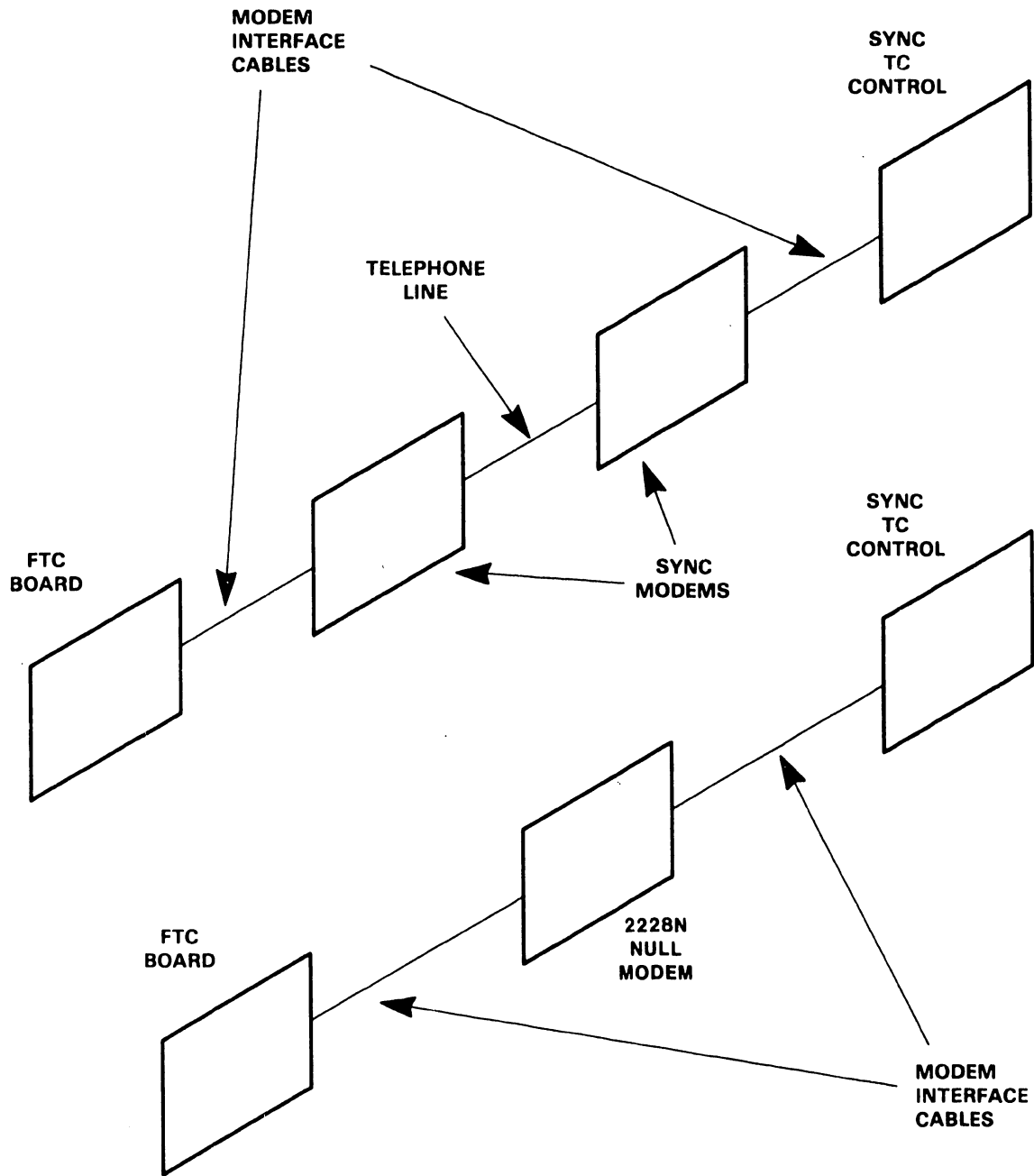

FIGURE 4-12 TYPICAL COMMUNICATIONS CONFIGURATION - W4-FTC-BATCH PROTOCOL

Table 4-3

Direct Connection Cables

25'	220-2236-25	700'	220-2236-7
50'	220-2236-50	800'	220-2236-8
100'	220-2236-1	900'	220-2236-9
200'	220-2236-2	1000'	220-2236-10
300'	220-2236-3	1250'	220-2236-11
400'	220-2236-4	1500'	220-2236-12
500'	220-2236-5	1750'	220-2236-13
600'	220-2236-6	2000'	220-2236-14

The following paragraphs describe modem requirements for the various protocols. The null modems used in the TTE and Batch protocols allow operation at a maximum speed of 9600 baud; the two systems/terminals must be set for the transmission speed.

4.8.2.1 Modem Requirements - W4-FTC-TTE Protocol

The asynchronous modems used in conjunction with W4-FTC-TTE must be:

- Full or half duplex (the two modems must be the same).
- Same or compatible model.
- Suitable for line type.
- Capable of the desired transmission speed.
- Set for the same transmission speed.
 - Switched line - 1200 baud maximum.
 - Leased line - 9600 baud maximum.

4.8.2.2 Modem Requirements - W4-FTC-2236 Protocol

The asynchronous modems used in conjunction with W4-FTC-2236 must be:

- Asynchronous.
- Full duplex.
- Same or compatible model.
- Capable of transmitting at least 11 bits per character: one start bit, eight data bits, one parity bit, and at least one stop bit.
- Suitable for line type.
- Capable of the desired transmission speed.
- Set for the same transmission speed.
 - Switched line - 1200 baud maximum.
 - Leased line - 9600 baud maximum.

4.8.2.3 Modem Requirements - W4-FTC-BATCH Protocol

The asynchronous modems used in conjunction with W4-FTC-BATCH must be:

- Full or half duplex (the two modems must be the same).
- Same or compatible model.
- Suitable for the line type.
- Capable of desired transmission speed.
- Set for the same transmission speed (The Wangwriter and the terminal/processor must be able to operate at this speed).

4.8.3 FTC BOARD INSTALLATION

The FTC board is to be installed in the Wangwriter as the inside-most logic board, nearest the frame (see Figure 2-3, sheets 3 and 4). Perform the following:

1. Power off the Wangwriter, and disconnect the ac power cable.
2. Disconnect keyboard and CRT display signal cables from the PCA connectors at the rear of the unit.
3. Remove right side cover from the unit.
4. Remove the three nuts from the board support studs; remove the two screws which attach each board connector bracket to the frame bracket.
5. Disconnect the signal and power connectors from the PC boards.
6. Remove all three PC boards (Printer Driver, CPU/Disk/Keyboard, and CRT/Memory).
7. Remove one spacer from each of the three board mounting studs.
8. Remove one filler plate from the connector bracket, and keep the two screws.
9. After unpacking the FTC board, check that the board is not damaged, and that the 80 ZIF connector pins are straight.

NOTE

The switches on the FTC board are not used at this time; the switches should be in OFF position.

4.8.3 FTC BOARD INSTALLATION (continued)

10. Insert FTC board over the mounting studs, and install the two screws (removed in step 8) through the PC board support bracket, into the PC board connector bracket.
11. On the CPU board, 210-7977, set switch 5 of switch-bank No. one to ON position.

NOTE

When the CPU board is replaced on any system using the FTC board, switch 5 must be set to ON.

12. Reinstall the three PC boards removed in step 6, and carefully connect the power and signal cables.
13. Install all screws in the connector brackets, plus the three nuts on the board mounting studs.
14. Replace side cover on the cabinet, and reconnect cables for the CRT, the keyboard, and the ac power.

4.8.4 DIAGNOSTIC/VERIFICATION TESTS

Perform the following:

1. Install appropriate loopback test connector (e.g., WLI No. 420-1040 for RS-232) on the FTC board modem cable connector.
2. Turn system power on.
3. Insert diagnostic disk (732-8001 R1) in the system disk drive to load the the diagnostic software.
4. Select FTC test 1290 from the main menu.
5. From the FTC test menu, perform steps 1 and 2; next, in step 3, press either the "1" key to select the RS232 Loopback Test or one of the other keys as required for a specific test. The program should cycle continuously, and the program-loop count should increment approximately every 10 seconds. Should any errors occur, refer to the error codes in the FTC test documentation (Doc. Rev. 9290). Allow the program to cycle at least 10 times.

6. Cancel FTC test, and replace the scratch disk with the Diagnostic disk. Select other system tests, e.g., Memory, VCO, Printer, etc., to verify that the system is operating correctly.
7. After running system diagnostics, remove diagnostic disk and shut down system power.
8. Remove RS-232 Loopback Connector.
9. Connect modem cable to the FTC board connector, and tighten mounting screws.
10. Load appropriate FTC operating system software, and perform a live on-line test with the host system. Follow the operating instructions provided with the software disk.

4.8.5 OPERATING STATUS CHECKS

The FTC board has a seven-segment LED which displays the interface modem-control signal status. The signals indicated by the various segments are as follows:

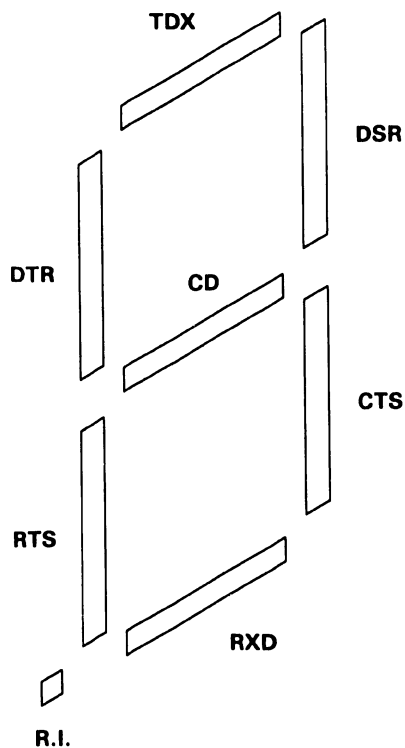

4.8.5 OPERATING STATUS CHECKS (continued)

TXD = Transmit Data	- OUTPUT -	Flashes when data is transmitted
RXD = Receive Data	- INPUT -	Flashes when data is received
DSR = Data Set Ready	- INPUT -	Always on during normal operation
DTR = Data Terminal Ready	- OUTPUT -	On during normal operation
RTS = Request to Send	- OUTPUT -	On during transmit in half-duplex mode - Always on in full-duplex mode
CTS = Clear to Send	- INPUT -	On during transmit in half-duplex mode - Always on in full-duplex mode
RI = Ring Indicator	- INPUT -	On when data phone rings
CD = Data Carrier Detect	- INPUT -	On when receiving data in half-duplex mode - Always on in full-duplex mode

CHAPTER

5

PREVENTIVE AND CORRECTIVE MAINTENANCE

CHAPTER 5

PREVENTIVE AND CORRECTIVE MAINTENANCE

This chapter describes:

- Preventive Maintenance: The periodic inspection and lubrication of the system to reduce rate of failures.
- Corrective Maintenance: The adjustment, calibration, and replacement of components as required to restore the system to proper working order.

5.1 PREVENTIVE MAINTENANCE

Preventive maintenance is the normal cleaning and inspection which is done either every year, every 500 hours of operation, or at each service call - whichever occurs first. The printer needs cleaning and minimal lubrication, followed by visual inspection of the print quality. The time required for these procedures is about 15 minutes.

5.1.1 CLEANING AND INSPECTION

1. Remove power from printer, and open or remove covers.
2. Inspect the printer, including the carriage drive cable system, for signs of wear and loose or broken hardware. Check the platen and carriage system for looseness or wobble and for foreign materials.
3. Remove the platen, paper cradle, ribbon cartridge and printwheel and inspect for signs of wear.

4. Clean the printer. Remove paper residue, ink, dust, etc., with alcohol-saturated cleaning pads and wipers. Check particularly the carriage rails and pulley grooves.
5. Clean the platen, platen pressure rollers, and paper bail rollers with Fredron Platen Cleaner, or equivalent. Do not use alcohol on these items.
6. Clean the hammer actuator with a cloth or brush.

5.1.2 LUBRICATION

Lubricate the printer as follows: DO NOT EXCEED THE RECOMMENDED AMOUNTS.

1. Carriage rail bearing: put 4 or 5 drops of #10 weight oil on either side of the carriage, and move carriage back and forth.
2. Remove the two caps from the hammer armature pivots, and apply IBM #23 grease on pivot pin. Do not oil the parts. To locate the lubrication points, refer to Figure 5-1.

5.1.3 VISUAL INSPECTION (Figure 5-2)

Printing characteristics to check are:

1. Character Spacing: A row of uppercase "H"'s shows any spacing problems present in the machine.
2. Print Consistency: Type a sentence such as "The quick brown fox...", which uses all the alphabet in a random order.
3. Condition of the Print Wheel (Worst Case): Check I, E, H, X
4. Evenness: Type a line of under-scores.
5. Line Spacing: Six line feeds equals one inch.

- 1 APPLY IN SMALL AMOUNTS-USE OIL SYRINGE
- 2 APPLY IN SMALL AMOUNTS-USE GREASE SYRINGE
- 3 APPLY THIN FILE TO SHOCK MOUNT SURFACES
- 4 USE LIGHT MACHINE OIL FOR CARRIAGE GUIDE SHAFTS

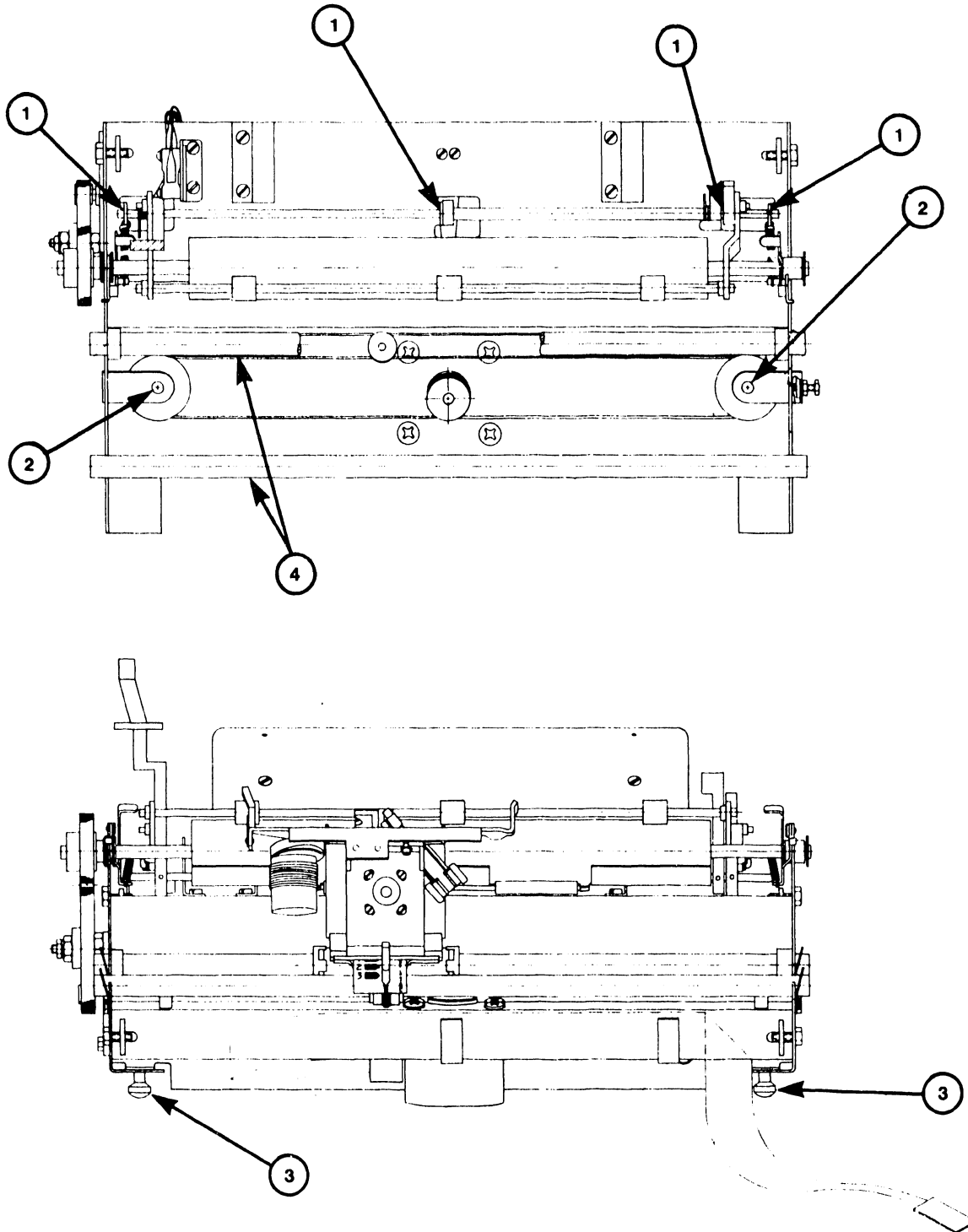
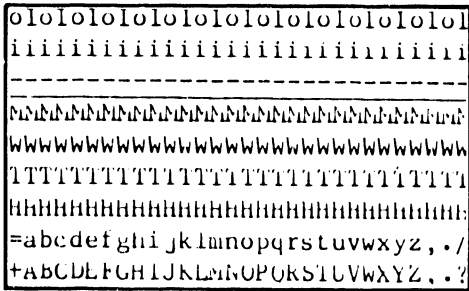
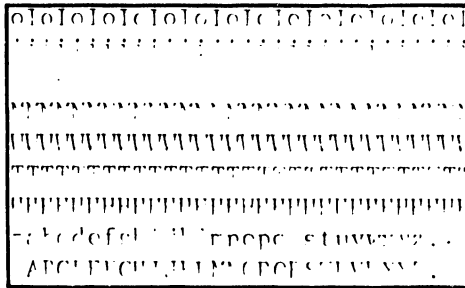

FIGURE 5-1 PRINTER LUBRICATION POINTS



**LETTERS TOO LIGHT AT TOP - EITHER
PRINT WHEEL ADJUSTED TOO CLOSE
TO PLATEN OR HAMMER ADJUSTED TOO
HIGH**



**VERY LIGHT - PRINT WHEEL TO
PLATEN GAP TOO GREAT**

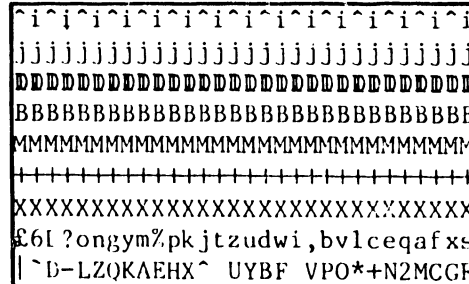

**LETTERS OUT OF ALIGNMENT -
HOME POSITION TOO FAR RIGHT,
"O" TWO CHARACTERS TO
THE RIGHT**

FIGURE 5-2 PRINTER ADJUSTMENTS (1 OF 2)

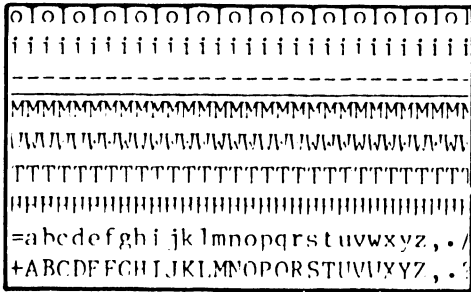

**LETTERS TOO LIGHT AT BOTTOM -
HAMMER EITHER TOO CLOSE TO
PLATEN OR ADJUSTED TOO LOW**

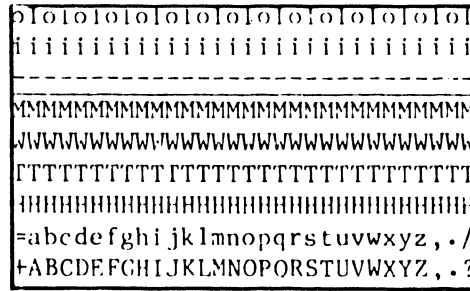

PROPER ADJUSTMENT

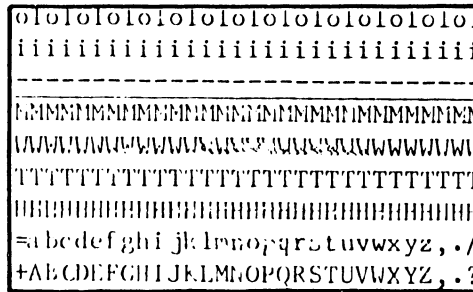

**LIGHT PRINT - EITHER PRINT SOLE-
NOID ARM-TO-LAMINATION GAP TOO
SMALL OR HAMMER-TO-PLATEN GAP
TOO GREAT**

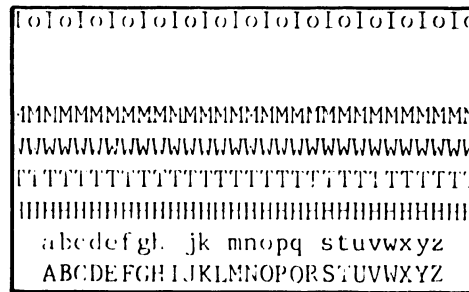

**SMALL CHARACTERS NOT PRINTING -
PRINT SOLENOID ARM-TO-LAMINA-
TION GAP TOO LARGE**

FIGURE 5-2 PRINTER ADJUSTMENTS (2 OF 2)

5.2 CORRECTIVE MAINTENANCE

Corrective maintenance comprises checks and adjustments, and components replacement, possibly indicated as necessary by diagnostic test results. Paragraph 5.2.1 describes component checks and appropriate adjustments; paragraph 5.2.2 describes component replacement.

5.2.1 CHECKS AND ADJUSTMENTS

This paragraph describes checks and adjustments for:

- Printer Assembly
- Disk Drive
- Video Monitor

All apparently faulty mechanical assemblies and components should be checked for proper adjustment before removal or replacement. If the check shows them as out-of-tolerance, correct the adjustment. Only if proper adjustment fails to correct the problem, should components be removed or replaced. Always go through the adjustment and/or alignment procedures after replacing a mechanical part or assembly.

Some adjustment procedures require removal of the side covers of the printer. To remove the covers see the instructions in paragraph 5.2.2.

The following tools and equipment may be needed for adjustment and/or alignment.

Alignment Disk (printer	WL 580-0152
Knob	WL 655-0274
Alignment Diskette	WL 726-8068
Pin Gauge, .030"/.060"	WL 726-9726
Diagnostic Diskette	WL 732-8001
Loopback Connector RS232	WL 420-1040
Alignment/Tension Tool (PRT)	WL 580-0225
Cable Clamp, Printer Carriage	WL 580-0311
Gram Gauge	WL 726-4417

5.2.1.1 Printer Assembly

Printer assembly aspects checked/adjusted are:

- Print-wheel-to-platen gap
- Hammer-to-platen gap

- Print hammer angle
- Print wheel home position
- Print solenoid arm and lamination
- Cord tension
- Backlash
- Card guide
- Left margin home position
- End-of-ribbon sensor
- Ribbon drive
- Daisy wheel damper
- Ribbon height

5.2.1.1.1 Print Wheel to Platen Check

This check determines whether the characters on the printer Daisy wheel are positioned at the proper distance from the printer's platen. The check is made by replacement of the Daisy wheel with an alignment disk and use of the alignment tool to gauge the print-wheel-to-platen gap. The alignment is correct if possible to insert the alignment tool between the two with little effort and if there is a very slight drag on the alignment tool when it is worked back and forth between the two.

Do the print wheel to platen adjustment (para 5.2.1.1.2) only if the gap is incorrect. Check the print-wheel-to-platen gap as follows:

1. With system power off, remove the print wheel from the carriage motor assembly.

NOTE

Be certain to support assembly by grasping Hammer Housing assembly with one hand during step 2.

2. Insert print wheel alignment disk (WL #580-0152) in place of the Print Wheel (alignment disk's raised side should be positioned toward the hub). (See Figure 5-3.) Hold alignment disk in place by a knob (WL #655-0274).
3. Lift bail roller assembly away from platen.
4. Return daisy motor assembly to its normal operating position (holding by hammer housing assembly). Be certain that the daisy motor assembly is properly seated.
5. Set small end of the hammer gauge (WL #580-0225) forward on the platen in line with the alignment disk (Fig. 5-4).
6. With the alignment disk and alignment tool in position and the copy control lever in position 1 indent, remove/insert alignment tool. The alignment tool should just lightly contact the disk.

NOTE

Under these circumstances, the gap between the platen and print wheel is within 0.095 and 0.105 inch (0.240 and 0.270 cm). (See Figure 5-5.)

7. Rotate print wheel approximately 180 degrees and ensure a happy medium at both positions.
8. Remove alignment tool, knob, and alignment disk (by grasping the alignment disk perimeter).
9. Replace print wheel. Put carriage assembly in its normal operating position. Replace ribbon.

5.2.1.1.2 Print Wheel to Platen Adjustment

1. With the power off, remove the print wheel from the carriage assembly.
2. Remove Print Wheel by grasping and pulling hub firmly to release.

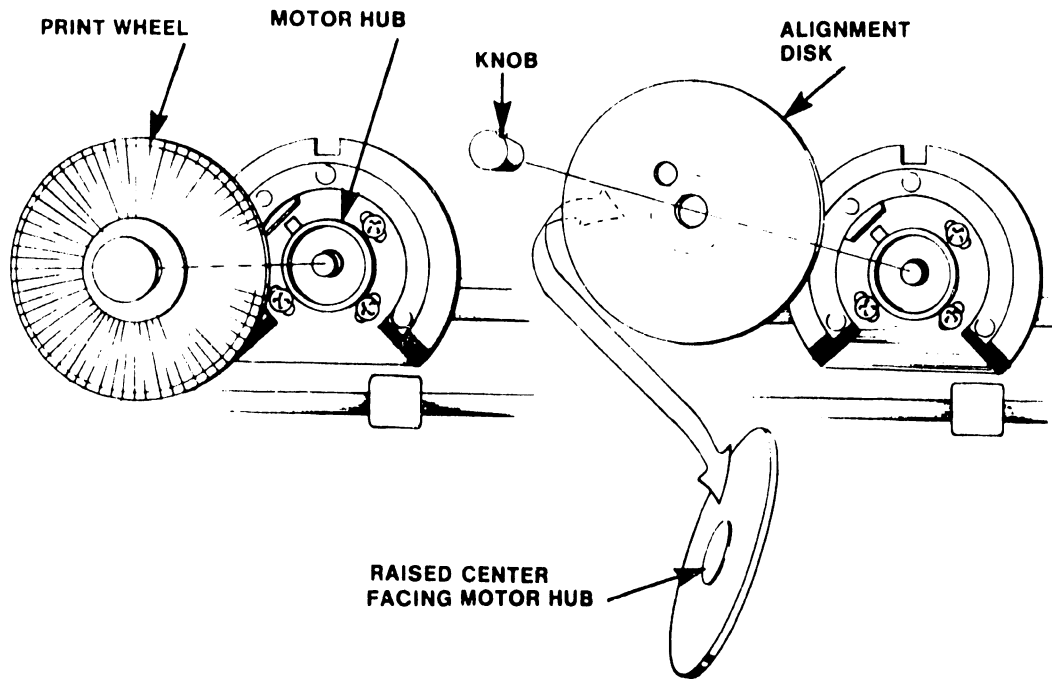

FIGURE 5-3 PRINT WHEEL AND ALIGNMENT DISKS

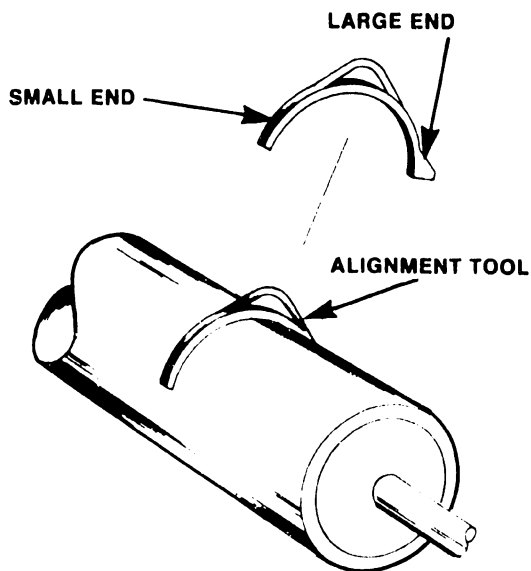

FIGURE 5-4 ALIGNMENT TOOL USING SMALL END

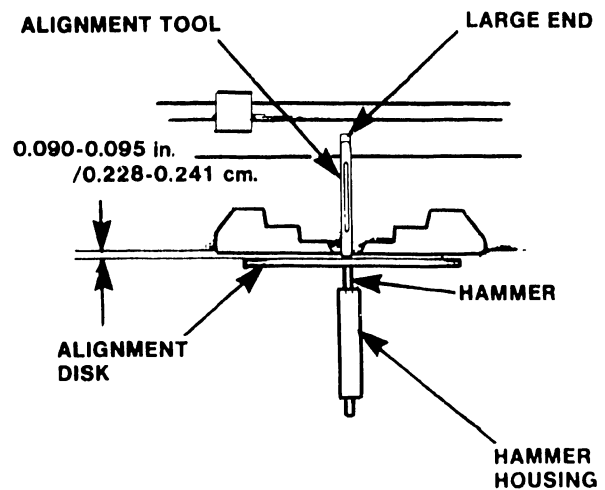

FIGURE 5-5 PRINT WHEEL-TO-PLATEN SPACING

NOTE

Be certain to support assembly by grasping Hammer Housing assembly with one hand while performing step 3.

3. Insert alignment disk (WL #580-0152) in place of the Print Wheel (alignment disk's raised side should be positioned toward the hub). (See Figure 5-3.) Alignment disk is held in place by a knob (WL #655-0274).
4. Lift bail roller assembly away from platen.
5. Return carriage assembly to its normal operating position (holding by hammer housing assembly). Be certain the daisy assembly is properly seated.
6. Set the small end of the alignment tool (WL #580-0225) forward on the platen in line with the alignment disk (Fig. 5-3).
7. Loosen four Phillips head screws on the carriage assembly (Fig. 5-6) and then tighten them so they are only slightly snug.
8. Snap the daisy motor assembly into its normal operating position (grasp by hammer housing).
9. Set the small end of the alignment tool (WL #580-0225) forward on the platen in line with the alignment disk (Fig. 5-4).
10. Adjust the carriage assembly so that the alignment tool fits loosely between the alignment disk and the platen and the carriage assembly is parallel with both the platen and the carriage base plate (the assembly on which it is mounted). See Fig. 5-6.
11. Tighten the four Phillips head screws and repeat the check as a final adjustment.
12. Remove alignment tool and alignment disk; replace print wheel and ribbon.
13. Return printer to normal operating condition and print a test document which contains lines of all capital letters.
14. Check printout for even printing of all characters and repeat portions of this procedure as necessary to achieve normal printing.

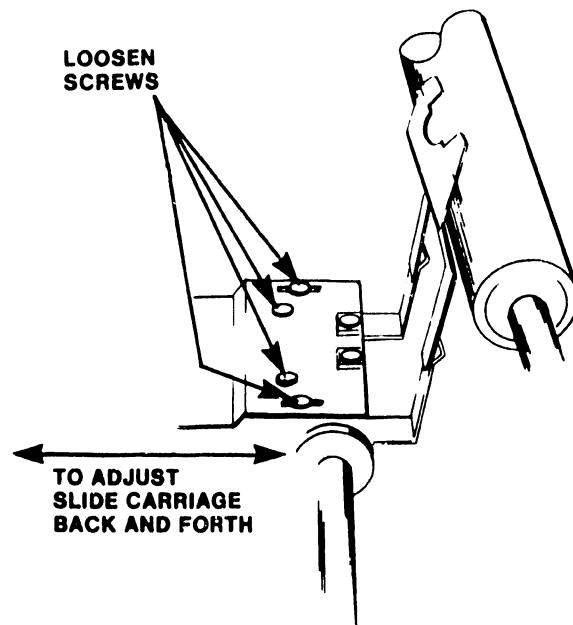

FIGURE 5-6 PRINT WHEEL TO PLATEN ADJUSTMENT

5.2.1.1.3 Hammer-to-Platen Check

1. Remove print wheel; close daisy assembly and make sure it is seated in the latch.
2. Set large part of the alignment tool (WL #580-0225) forward on the platen in line with print hammer (see Figures 5-7 and 5-8). With the print wheel removed and the copy-control lever in position 1, the large end of the alignment tool should just touch the hammer.

NOTE

Under these conditions, the gap between the platen and hammer will be within 0.242 to 0.248 inch (0.610 to 0.630 cm).

3. Perform the adjustment procedure if necessary. Otherwise, return the printer to normal operating conditions.

5.2.1.1.4. Hammer-to-Platen Adjustment

To adjust for the proper clearance between the hammer and the platen, perform the following procedure.

1. With the large end of the alignment tool on the platen in line with the hammer, loosen the two screws that mount the yoke assembly to the motor (see Figure 5-9).
2. Move yoke assembly until the hammer just touches the large end of the alignment tool.
3. Tighten the two screws and return the printer to normal operating conditions.

5.2.1.1.5 Print Hammer Angle Check

1. Print a test document with lines of capital letters (especially M's and H's).
2. Perform the print hammer angle adjustment (para. 5.2.1.1.6) if characters do not print with the same density at both the top and bottom of each character.

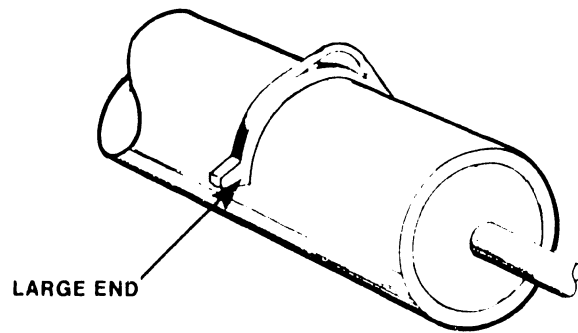

FIGURE 5-7
ALIGNMENT TOOL USING LARGE END

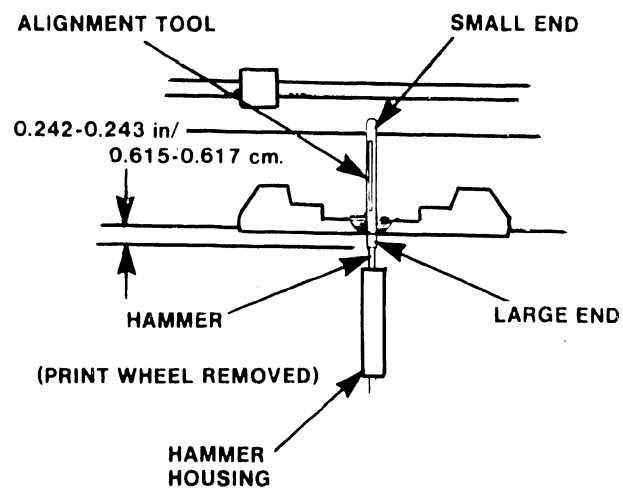

FIGURE 5-8
HAMMER-TO-PLATEN CHECK

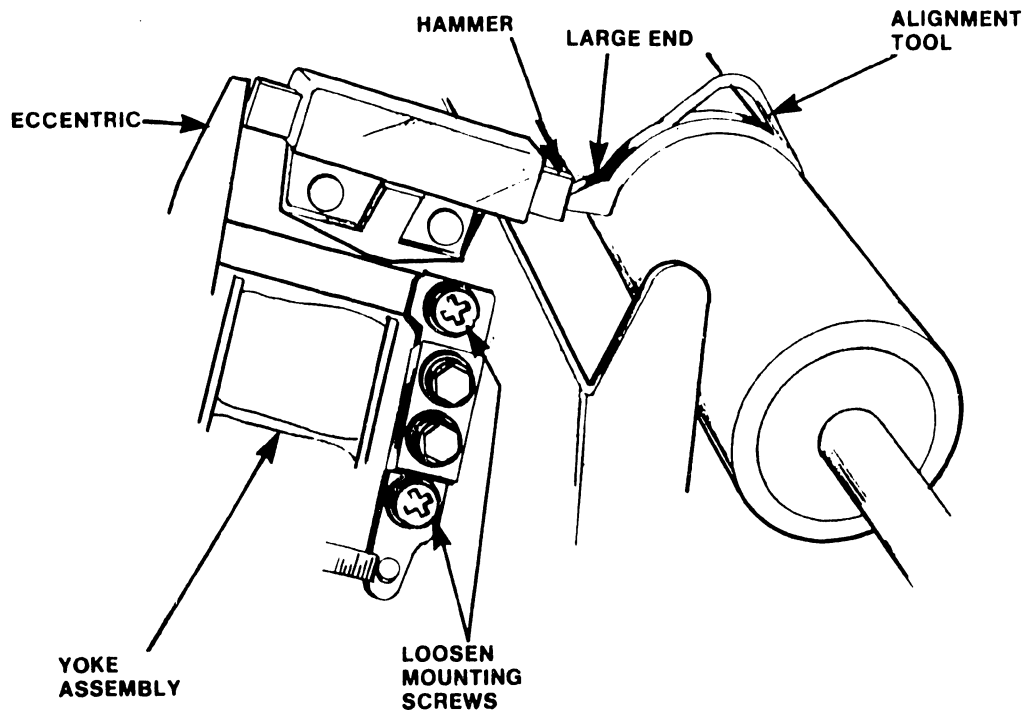

FIGURE 5-9 HAMMER-TO-PLATEN ADJUSTMENT

5.2.1.1.6 Print Hammer Angle Adjustment

1. Loosen the two hammer housing mounting/adjusting screws (Fig. 5-10).
2. Shift angle of the hammer and hammer housing so that even pressure is on the characters during printing; tighten screws.
3. Print test document with lines of capital letters (especially M's and H's).
4. If characters do not print with the same density at the top and bottom of each character, repeat this adjustment. If adjustment does not enable top-of-character printing, refer to printer trouble analysis, Chapter 8.

5.2.1.1.7 Print Wheel Home Position Check

NOTE

See Diagnostics, Chapter 8 (Printer - Mechanical Test) for alternate method of checking print wheel home position. The diagnostic test is preferred for accurate alignment.

1. Turn power ON
2. Load system disk.
3. Remove ribbon.
4. Select printer.
5. Pull carriage assembly back.
6. Check to see if the print wheel home position (lower case letter o) is in normal position in line with the hammer as shown in Figure 5-11. If not in alignment, note how far off the lower case o is from normal position.
7. Perform the home position character adjustment below.

5.2.1.1.8 Print Wheel Home Position Adjustment

If the home character position is off by two, adjust photo sensor with the steps below. Adjustments of less than one should be performed at depot level.

1. De-select printer.
2. Pull carriage assembly back to service position.

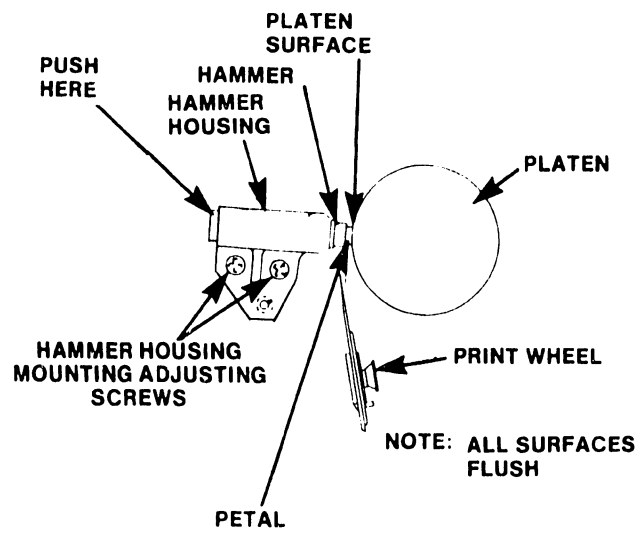
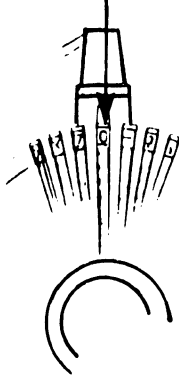

FIGURE 5-10 HAMMER CHECK AND ADJUSTMENT

HOME POSITION L.C.O.



(a)
HOME POSITION

HOME POSITION

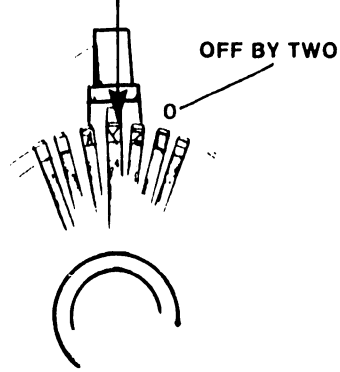

(b)
OFF BY TWO

HOME POSITION

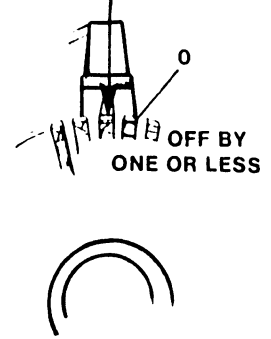

(c)
OFF BY ONE OR LESS

FIGURE 5-11 PRINT WHEEL POSITIONS

OFF BY TWO ADJUSTMENT

PHOTO
SENSOR
MOUNTING
NUTS

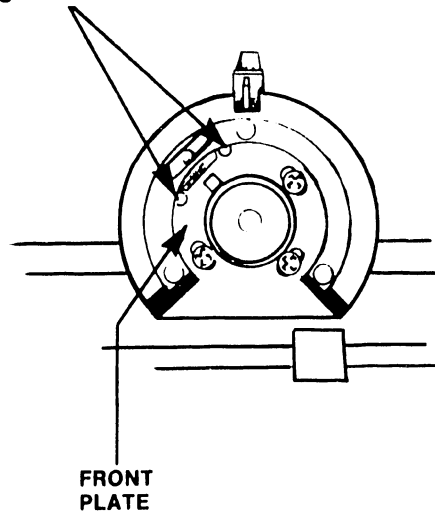

FIGURE 5-12 HOME POSITION ADJUSTMENTS

3. Remove print wheel.
4. Loosen 2 mounting nuts (see Figure 5-12).
5. Move sensor to right if lower case o is to the left of home position and vice versa. Tighten nuts.
6. Put print wheel on.

CAUTION

Never leave carriage in service position when selecting printer.

7. Select printer.
8. Pull carriage assembly back.
9. Observe home position alignment.

5.2.1.1.9 Print Solenoid Arm and Lamination Check and Adjustment

To check:

1. Remove ribbon cartridge and print wheel.
2. Push print solenoid arm all the way forward towards the platen.
3. Inspect the alignment of the print solenoid arm with respect to the face of the coil laminations; be sure that both surfaces are touching and parallel (see Figure 5-13). If alignment is incorrect, adjust as follows.

To adjust:

1. To adjust the print solenoid arm with respect to the face of the lamination, loosen coil assembly mounting screws (Figure 5-13).
2. Push print solenoid arm forward (toward platen) as far as possible and hold.
3. Move coil assembly until its lamination is touching and parallel with the print solenoid arm surface.
4. Tighten mounting screws while holding coil in place.

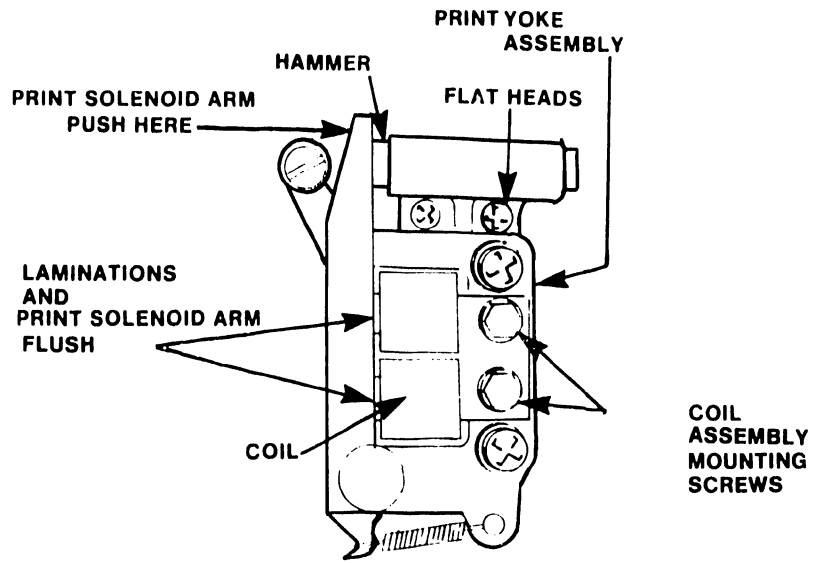

FIGURE 5-13 PRINT SOLENOID ARM AND LAMINATION ADJ.

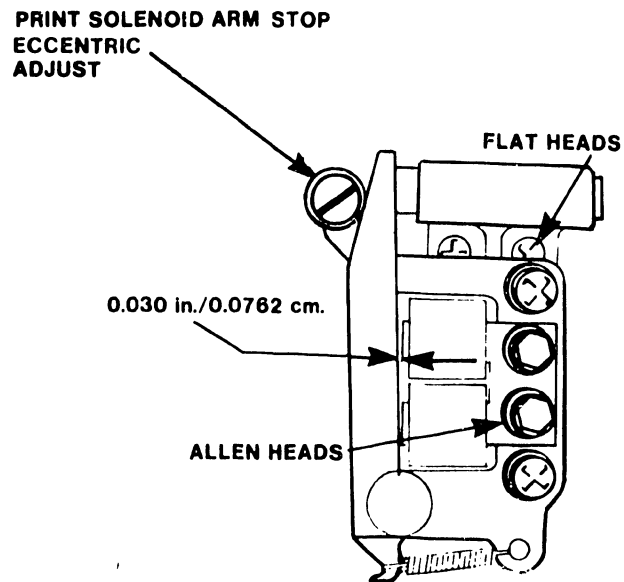

FIGURE 5-14 PRINT SOLENOID ARM TO-LAMINATION GAP

5.2.1.1.10 Print Solenoid Arm-to-Lamination Gap Check

The gap between the print solenoid arm and the (bottom corner of the top) core of the coil laminations is 0.030 inch (0.0762 cm). See Figure 5-14. Use the .030/.060 pin guage (WL #726-9726) to measure the gap.

5.2.1.1.11 Print Solenoid Arm-To-Lamination Gap Adjustment

1. Loosen lock nut on the print solenoid arm stop eccentric (Figure 5-14).
2. Adjust eccentric stop until the correct dimension is obtained (0.030 inch, 0.0762 cm).
3. Tighten lock nut.
4. Recheck hammer-to-platen check.

5.2.1.1.12 Cord Tension Check

The Hammer Gauge/Cable Tension Adjustment Tool (WL 580-0225) is needed to check the cord tension.

1. Position carriage at extreme left position.
2. Insert adjustment tool through the right-hand hole adjacent to the motor in the printer assembly base (see Figure 5-15), and engage carriage cord in the notch on the tool upper surface. The bottom surface of the tool must be flat against the printer chassis.
3. Check that the cord has sufficient tension to close the tension-measuring gap on the tool (tension should not be greater than is necessary to close the gap)
4. Position carriage at extreme right and repeat the cord tension measurement through the left-hand hole position adjacent to the motor. If either measurement shows a need for adjustment, go to the next paragraph.

5.2.1.1.13 Cord Tension Adjustment

1. Move carriage to the extreme left side of the printer.
2. Loosen lock nut on the right side of the printer frame (Figure 5-16).
3. Adjust tension of cord by turning the tension screw on the right side of the printer (see Figure 5-16).
4. Adjust the screw for correct tension when the carriage is on the left side of unit, as described in paragraph 5.2.1.1.12. Tighten lock nut.

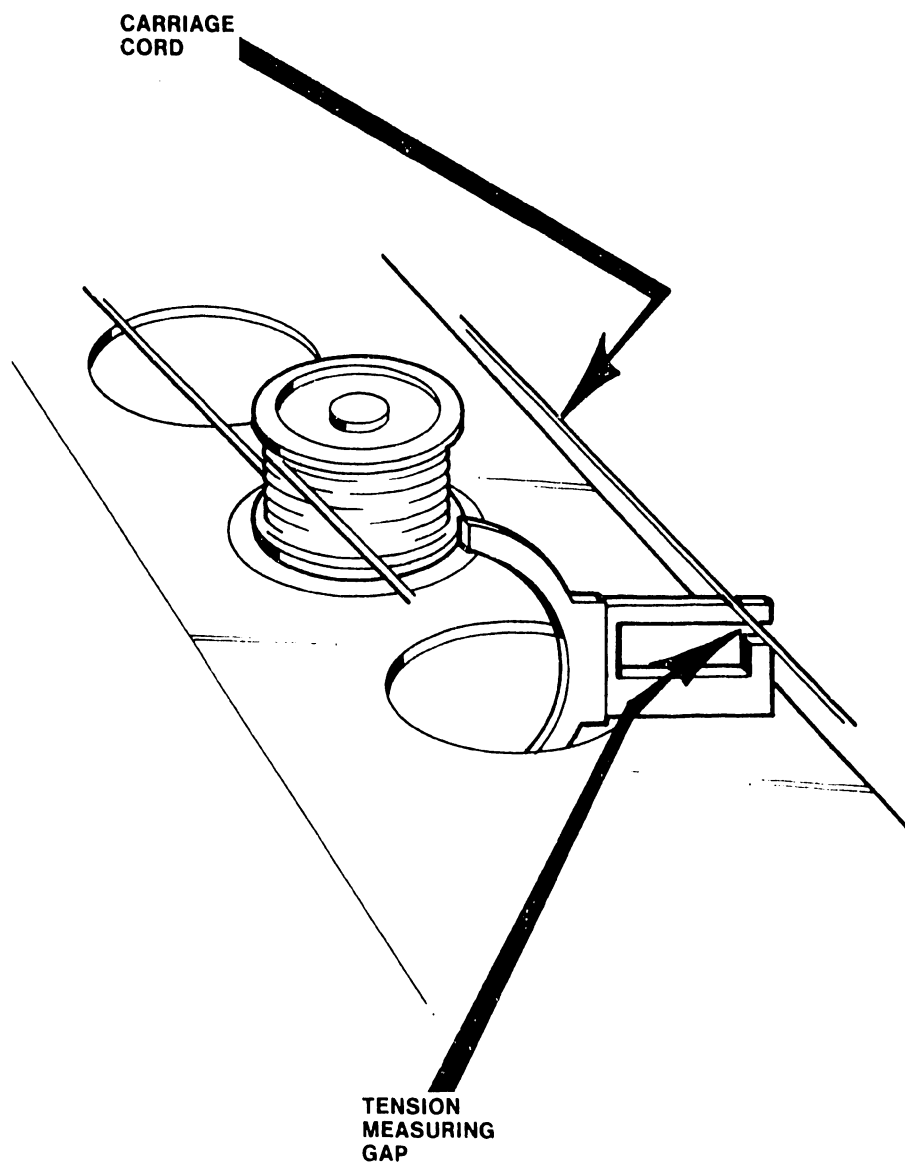

FIGURE 5-15 CORD TENSION CHECK

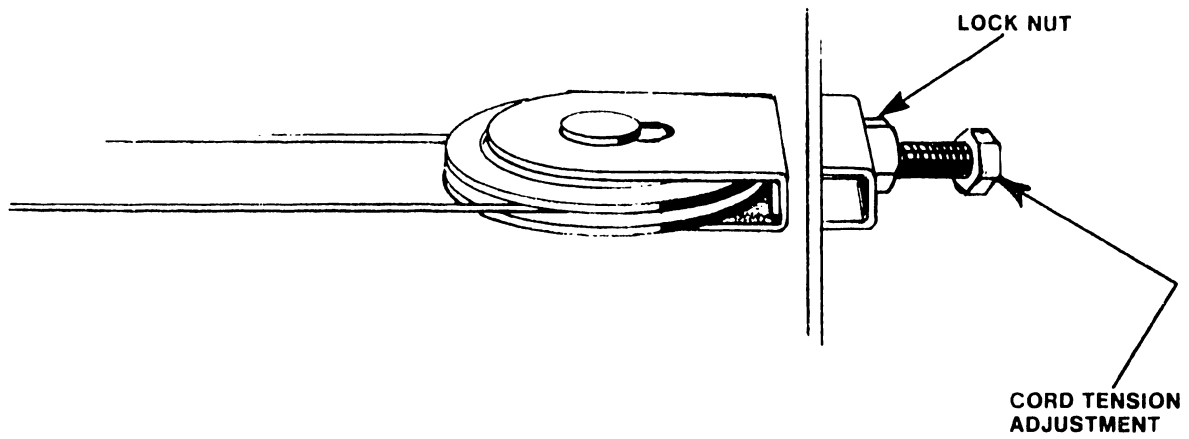

FIGURE 5-16 CORD TENSION ADJUSTMENT

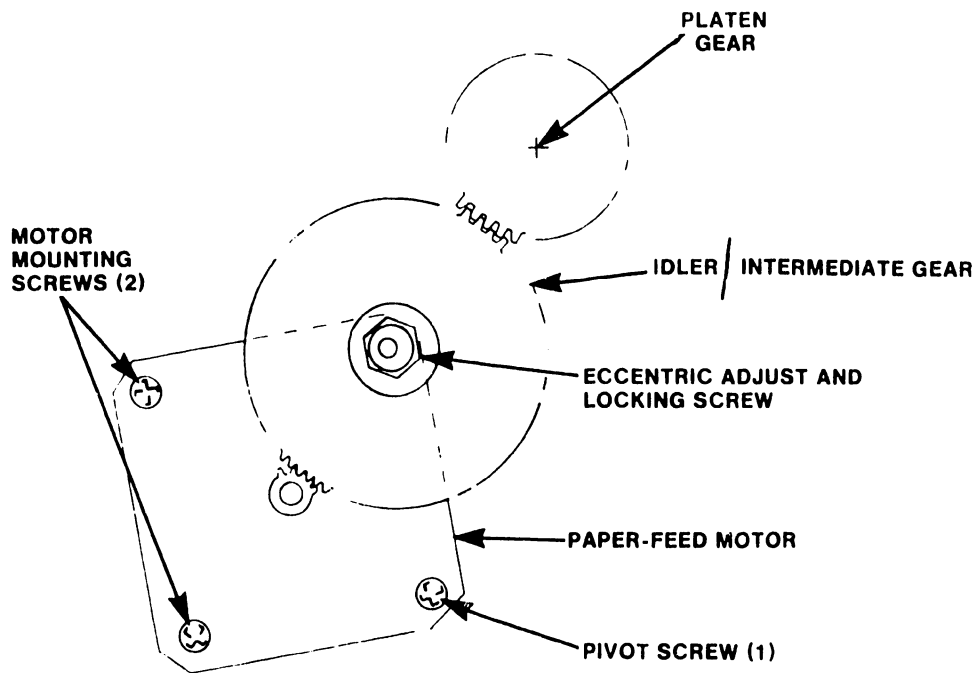

FIGURE 5-17 BACKLASH CHECK AND ALIGNMENT

5.2.1.1.14 Backlash Check

1. Turn power on.
2. Load system software.
3. Select printer.
4. Check backlash by rotating platen gear back and forth.
5. Deselect and rotate platen 90 degrees.
6. Select printer, and check for backlash again.
7. Repeat steps 5 and 6 until full 360-degree revolution is checked.

NOTE

Only a small amount of movement is acceptable. If movement is excessive, adjust backlash as described below. Ensure that platen gear mounting screw is tight before the adjustment procedure is performed.

5.2.1.1.15 Backlash Adjustment

1. Remove disk and turn off power.
2. Remove printer (see paragraph 5.2.2).
3. Loosen idler gear locking screw and adjust eccentric screw so that the backlash between the drive gear and idler gear is minimum (see Figure 5-17).

NOTE

Moving gears closer together reduces backlash. However, if the gears are too close the gear train binds. Check each adjustment for binding before continuing with procedures. Turn gears through 360 degrees while checking.

4. Tighten gear nut while holding eccentric nut in place.
5. Loosen the three motor mounting screws on plate and adjust the backlash between the idler gear and the platen gear (see Figure 5-17).
6. Tighten the three mounting screws while holding plate.

7. Install printer.
8. Perform backlash check again to determine the amount of backlash after adjustment.

5.2.1.1.16 Card Guide Check

1. Turn power on.
2. Load operating system (OS) software.
3. Remove OS software diskette (single-disk-drive system).
4. Load document for printing from archive diskette.
5. Select Print Document.
6. Name document.
7. Execute.
8. Select printing parameters.
9. Execute.
10. Insert paper.
11. Select Printer.
12. Print two lines, at least.
13. Check that the printing is horizontally aligned with the horizontal segment of the card guide as shown in Figure 5-18. Either the roll-up or the roll-down switch may be used to position the line of characters.
14. If alignment is incorrect, adjust as described below.

5.2.1.1.17 Card Guide Adjustment

1. Loosen the two card-guide mounting screws (see Figure 5-18).
2. Move card guide so that the horizontal segment of the card guide is parallel to the previously printed material.
3. Hold guide stationary and tighten screws.

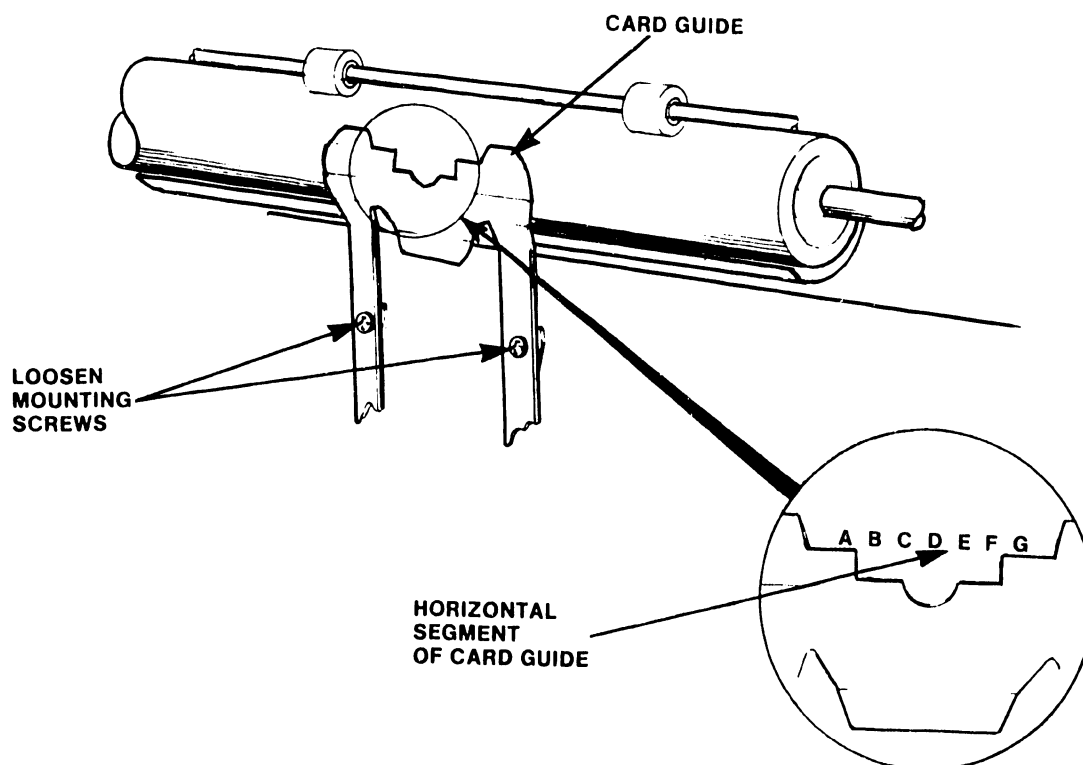

FIGURE 5-18 CARD GUIDE CHECK AND ADJUSTMENT

5.2.1.1.18 Left Margin Home Position Check

1. Turn power on and load OS software.
2. Remove OS software diskette (on single-disk system), and load document (archive) disk.
3. Select Print Document on menu.
4. Name document.
5. Execute.
6. Select printing parameters, left margin at 00.
7. Execute.
8. Insert Paper and SELECT Printer.
9. Print several lines.
10. Check that the left-margin home position is 0.55 ± 0.016 inch (1.4 ± 0.0 cm) from the left side of the paper when the margin is set at 00 on the print menu.

5.2.1.1.19 Left Margin Home Position Adjustment

1. Loosen screw that holds the photo flag (see Figure 5-19). Moving the photo flag towards the left increases the left margin width. Moving it right decreases margin width.
2. Slide the photo flag from side-to-side until left margin is 0.55 ± 0.016 inch (1.4 cm) from left side. It may be necessary to repeatedly re-cue the document and re-adjust the flag until the left margin is correct. Fine adjustments can be made by loosening of the four carriage motor mounting screws and turning the motor slightly.

NOTE

The Printer diagnostic (Mechanical - Test 6) can be used for alignment check (Chapter 8).

5.2.1.1.20 End of Ribbon Check

1. Use a test ribbon cartridge. To make a test cartridge, cut the ribbon on a used cartridge so that the metal spring in the sensor pocket reflects the LED light.
2. Insert test cartridge in system.
3. Turn on system and load OS software.

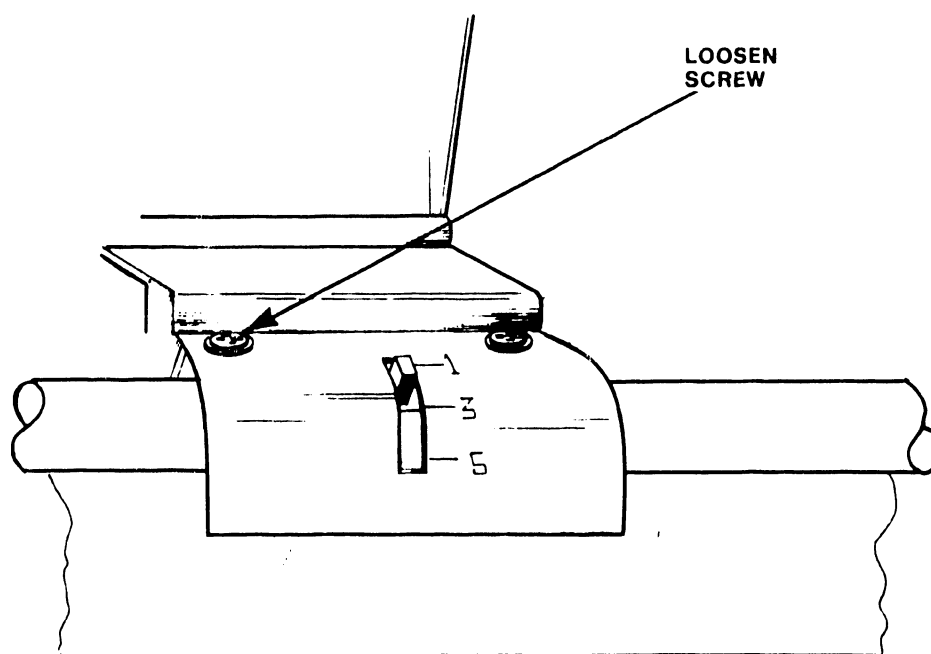

FIGURE 5-19 LEFT MARGIN HOME POSITION ADJUSTMENT

4. Observe that the "Change Ribbon" LED on the printer control keyboard is illuminated. If the LED is not illuminated, adjust sensor.

NOTE

A method of checking that the sensor is good uses any light reflecting flat metal tool, such as feeler gauge or screwdriver tip, in front of the sensor to activate the change-ribbon light. This may be used in conjunction with the diagnostic - Display and Keyboard - Chapter 8.

5.2.1.1.21 End-of-Ribbon Adjustment

1. Loosen mounting screws on sensor.

NOTE

Move carriage over hole in cross frame so that a screw driver can be used to loosen the screws on bottom of sensor.

2. Adjust sensor so that its active side is parallel to the pocket in the ribbon.
3. Repeat check to be sure change-ribbon panel LED illuminates.

5.2.1.1.22 Ribbon Drive Check

1. Remove ribbon cartridge.
2. Check that the ribbon drive has 8 to 12 ounces (224 to 336 grams) of spring tension (measure with gram gauge WL #726-4417 at the base of the spike driver). Push at base of spike driver as shown in Figure 5-20.

NOTE

Take reading when spike driver begins to move from the pressure applied by the gram meter.

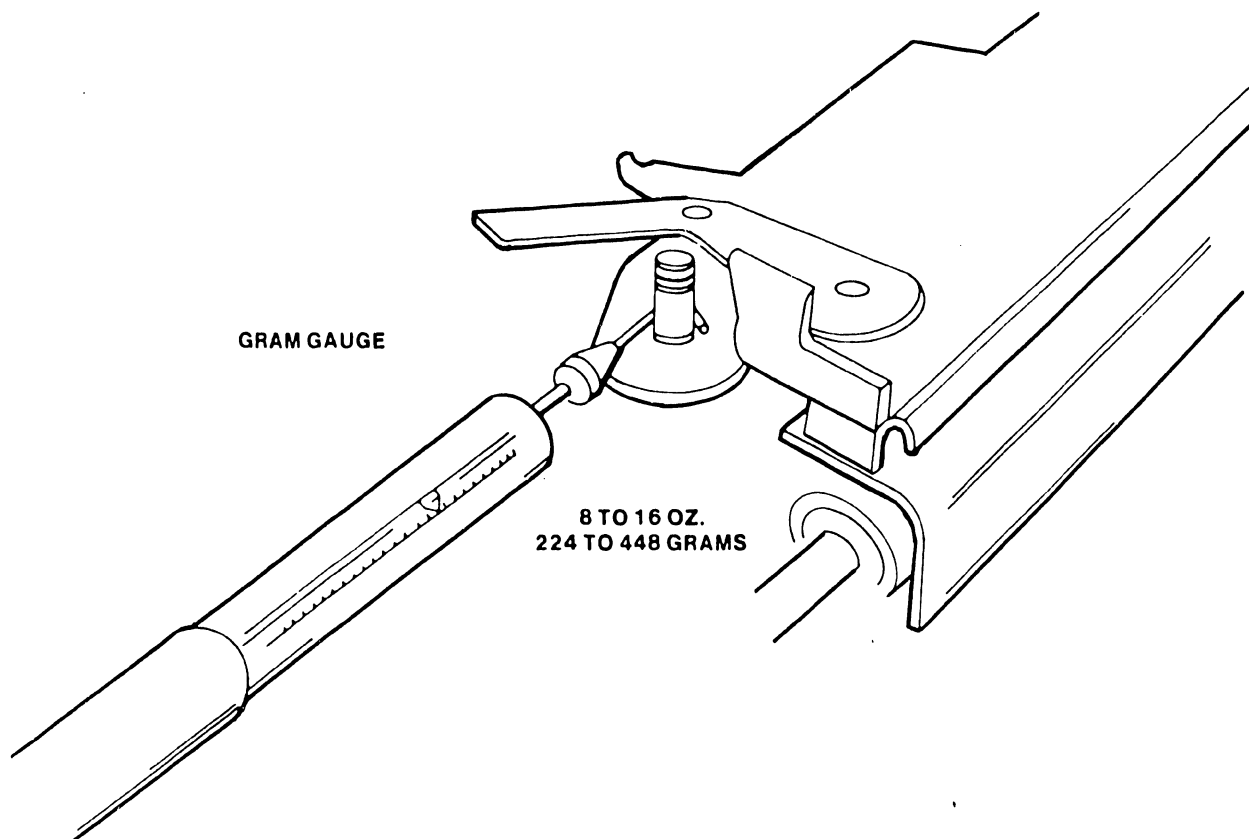

FIGURE 5-20 RIBBON DRIVE SPRING TENSION CHECK

5.2.1.1.23 Ribbon Drive Adjustment

1. Open grip ring and rotate it around motor (see Figure 5-21).

NOTE

From a top view rotate grip ring clockwise to increase tension and counter-clockwise to decrease tension.

2. Adjust for 8 to 12 ounces (224 to 336 grams).

5.2.1.1.24 Daisy Wheel Damper Check (Figure 5-22)

A misadjusted damper assembly may contribute to character spacing problems. To check the adjustment:

1. Tilt print head back.
2. Remove Ribbon.
3. Remove daisy wheel.
4. Place ruler edge across dampening bracket and daisy wheel hub (with ruler surface against the daisy wheel spindle). Verify that dampening bracket is set from 0.010" to 0.020" higher than the hub (a 0.010" feeler gauge should be insertable under the straight edge; a 0.020" feeler gauge should not be insertable).

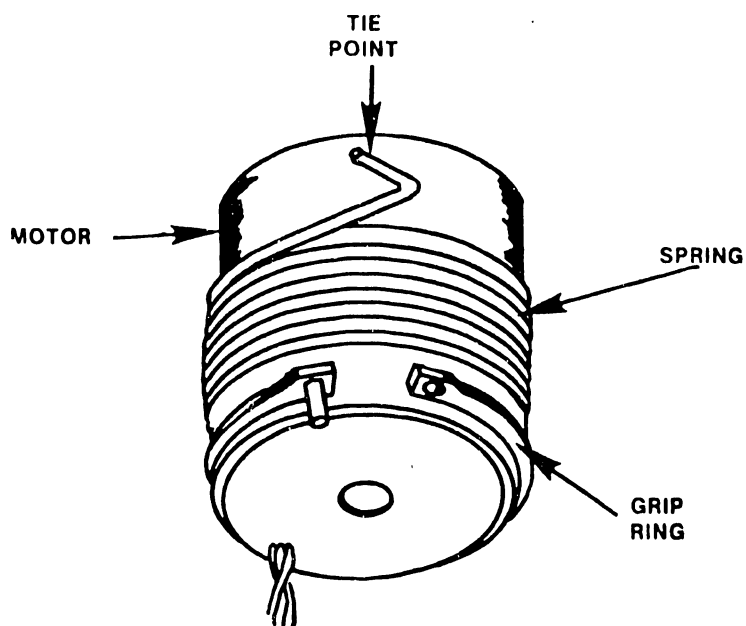

FIGURE 5-21 RIBBON DRIVE MOTOR

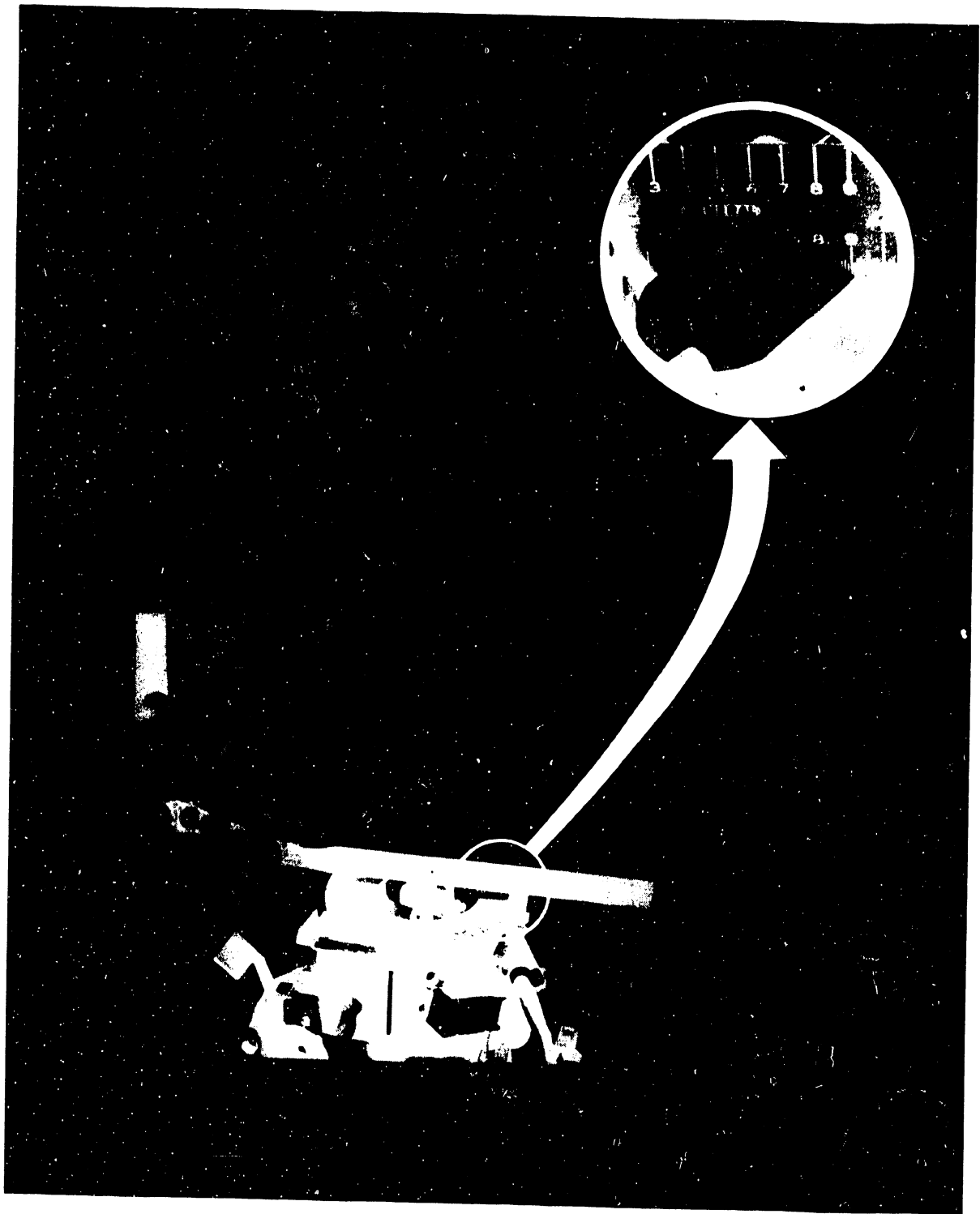

FIGURE 5-22 DAISY WHEEL DAMPER CHECK

5.2.1.1.25 Daisy Wheel Damper Adjustment

1. Remove the three Phillips Head screws to remove the dampening bracket. If the bracket is too low, go to step 2; if the bracket is too high, go to step 3:
2. Install shim washers WLI 653-0107 (0.005" thickness) as required (one or two) under each mounting post in addition to any existing shims. Go to step 4.
3. Remove shim washers Go to step 4.
4. Reinstall bracket, and verify adjustment per paragraph 5.2.1.1.24.

5.2.1.1.26 Ribbon-Height Check and Adjustment

The system diagnostics (Chapter 8) provides the means of verifying that printing is vertically centered on the ribbon. Test selection comprises the following menu sequence:

Main Diagnostic Menu

Printer

Mechanical

Ribbon Adjust

Should the test indicate a requirement for vertical ribbon adjustment, perform the following.

1. Remove ribbon.
2. Tilt print head back.
3. Use channel-lock pliers to grip ribbon platform (see Figure 5-23), and bend height tab either up or down, as required.

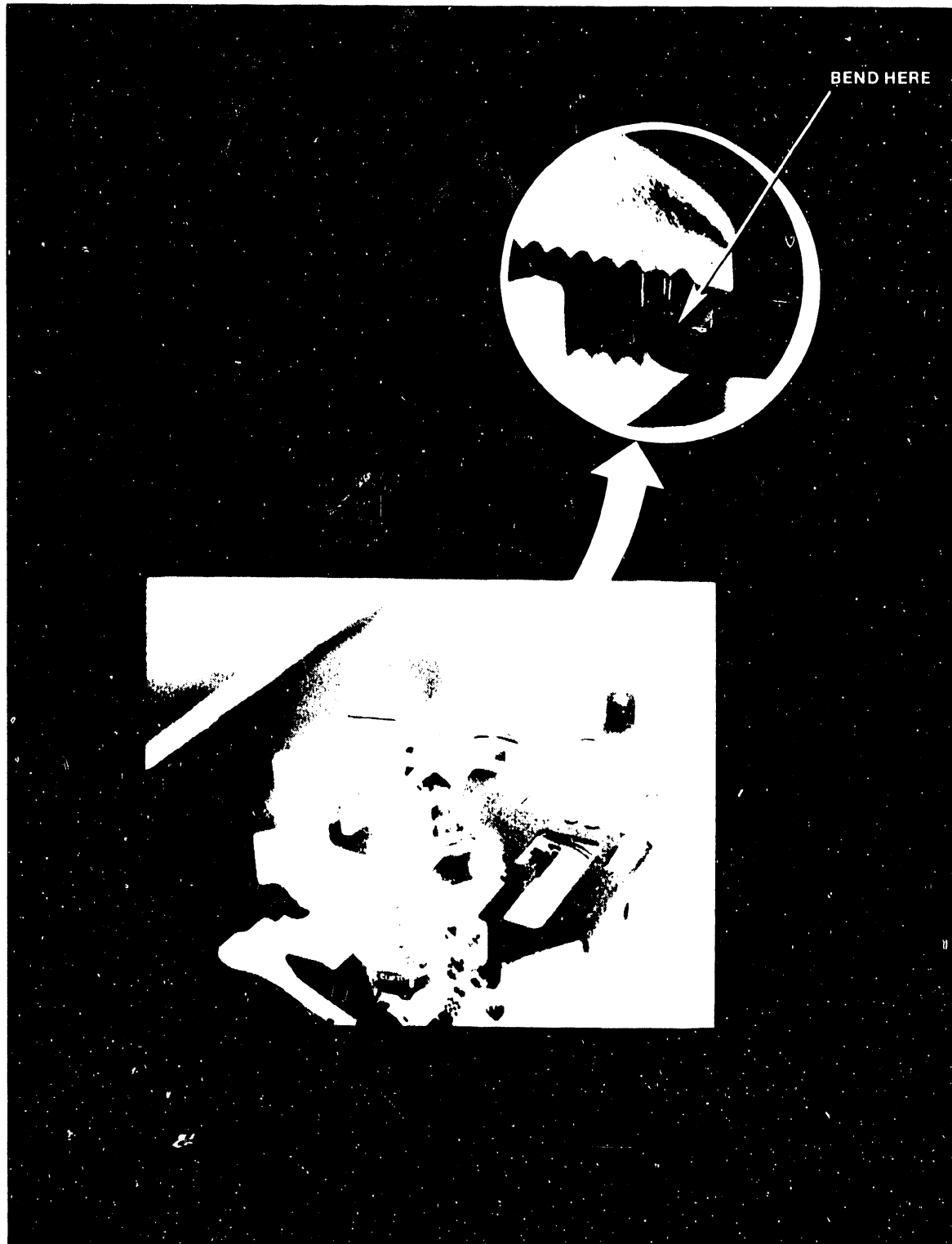

FIGURE 5-23 RIBBON-HEIGHT CHECK AND ADJUSTMENT

5.2.1.2 Disk Drive

Disk-drive aspects checked/adjusted are:

- Radial-track alignment
- Index-to-data alignment
- Track 00 sensor/switch
- Speed control
- Track 00 end stop
- Neoprene drive belt
- Phase-lock loop (VCO)

Most of maintenance of the disk drive consists of the checking and adjusting of the position of the read/write head relative to the disk radial tracks. Adjustments, especially those of the radial track alignment and the index sensor, could make it impossible to read minidiskettes written to by an out-of-adjustment drive. Customers must be aware of this possibility before drives are adjusted or replaced.

The system contains a PROM-loaded routine for disk drive checks and adjustments. To begin the routine:

1. Within 2 seconds of power turn-on, press CANCEL.
2. Within 2 seconds of pressing CANCEL, press INDENT. The PROM-loaded routine begins.
3. Insert an alignment diskette (WL #726-8068), the PROM-loaded routine begins disk track seeks. Pressing keys 0 through 6 seeks the tracks listed below.

<u>Key</u>	<u>Track</u>
W	Select head 0
E	Select head 1
0	0
1	1
2	2
3	3
4	16
5	32
6	34

Turning the system power off and then restarting the system restores the system to normal operation.

The disk drive in a system may be either an MPI Model 52 or a Tandon TM-100; therefore, the following procedures are identified as either MPI or Tandon where necessary.

These procedures require removal of the printer console side covers. Refer to paragraph 5.2.2.1 for removal procedure.

5.2.1.2.1 Radial-Track Alignment Check

The radial track procedure aligns head positioning. The alignment check/adjustment ensures that the track-16 position calculated by head positioning logic coincides with the track-16 position on an alignment disk.

1. Insert a CE alignment diskette (Wang Part No. 726-8068) and close the door.
2. Press keyboard numeric key 0 (zero) to go to track 00.
3. Sync scope on leading edge of index signal at the disk drive PCA:

MPI: at TP6 - ground clip at ground (lower end) of capacitor C30/C31 (see Figures 5-24 and 5-25).

Tandon: at TP7 - ground clip at TP6 (see Figure 5-25).

4. Connect A and B probes to:

MPI: TP1 and TP2 respectively (see Figure 5-24).
Connect ground probes to the ground end of capacitor C30/C31.

Tandon: TP1 and TP2 respectively. Connect ground probes to TP10.

Set scope to 50mv/cm, ac coupled, channel A and B added, with B inverted, 20ms/div.

5. Press key 4 to position the carriage at track 16. Stepper motor phases (MPI) should be:

phase 4 - J4-23 = 0V
phase 1 - J4-26 = 0V
phase 2 - J4-25 = +12V
phase 3 - J4-24 = +12V

6. Compare scope pattern to Figure 5-26 (equal amplitude). Press west directional keyboard key to select head 1, and repeat observation. If one lobe is less than 70% of the amplitude of the other lobe, on either side, adjust as described in paragraph 5.2.1.2.2.

5.2.1.2.2 Radial-Track Alignment

1. Set-up is the same as listed in paragraph 5.2.1.2.1.
2. With power on, adjust as follows: Alternately press directional east-west keys to select head 0 and head 1. If the individual patterns for the two heads do not have equal lobes, adjust so that the two lobe patterns are unequal in the same degree but in opposite directions. Adjust as follows:

MPI: Use the 0.050 wrench to loosen the set screw (Figure 5-27) in the stepper pulley and move the pulley to adjust the pattern. Finish by securing the pulley set screw with 2 inch-pounds of torque.

Tandon: Loosen (do not remove) the two module retaining screws (Figure 5-28) on the bottom of the chassis, and the one at the top rear of the module (Figure 5-29) Manually rotate the cam at the rear of the module to adjust the pattern. Finish by tightening the three retaining screws.

3. Verify alignment: Command successive seeks to track 00 (key 0), track 16 (key 4), track 32 (key 5), then return to track 16 (key 4). If the patterns shift, repeat adjustment and verify.

NOTE

If it is necessary to split the difference between adjustments to head 0 and head 1 and the resulting patterns have a smaller lobe less than 70% of the larger, the drive must be replaced (see paragraph 5.2.2).

5.2.1.2.3 Index-to-Data Check (Oscilloscope setting in paragraph 5.2.1.2.1)

The index-to-data alignment sets the timing between the sensing of the track index and the transmission of data. Interchangeability of minidiskettes requires a standardized index-to-data interval.

1. Verify the radial-track alignment (refer to paragraph 5.2.1.2.2).
2. Move the head to track 01 (key 1).
3. Set horizontal amplifier of the oscilloscope to 50 microseconds per division.
4. Check that scope shows a data pattern starting 200 \pm 50 microseconds from the start of the trace (see Figure 5-30).
5. If the pattern is out of tolerance, go to paragraph 5.2.1.2.4.

5.2.1.2.4 Index-to-Data Alignment

1. Set-up is the same as paragraph 5.2.1.2.3.
2. Remove mounting plate.
3. Prepare index sensor for adjustment:
 - MPI: Loosen two index sensor mounting screws in the recessed area at the back of the drive (see Figure 5-31).
 - Tandon: Loosen single retaining screw at the back of the drive (Figure 5-28) so that adjustment can be made with the flat-bladed screwdriver placed between the mounting block and chassis.
4. Slide sensor as necessary to obtain a data pattern starting 200 \pm 50 microseconds from the start of the trace (See Figure 5-30).
5. Tighten retaining screw(s) carefully so as not to disturb the adjustment (20 inch-ounce torque).

5.2.1.2.5 Track 00 Sensor/Switch Check

When the head is positioned over track 00, the track 00 sensor/switch generates a logic signal to disable head movement toward the disk outer edge. Align the sensor/switch to get a true reading of head position. The following references to logic 0 and logic 1 refer to voltages of 0.5V maximum and 4.0V minimum respectively.

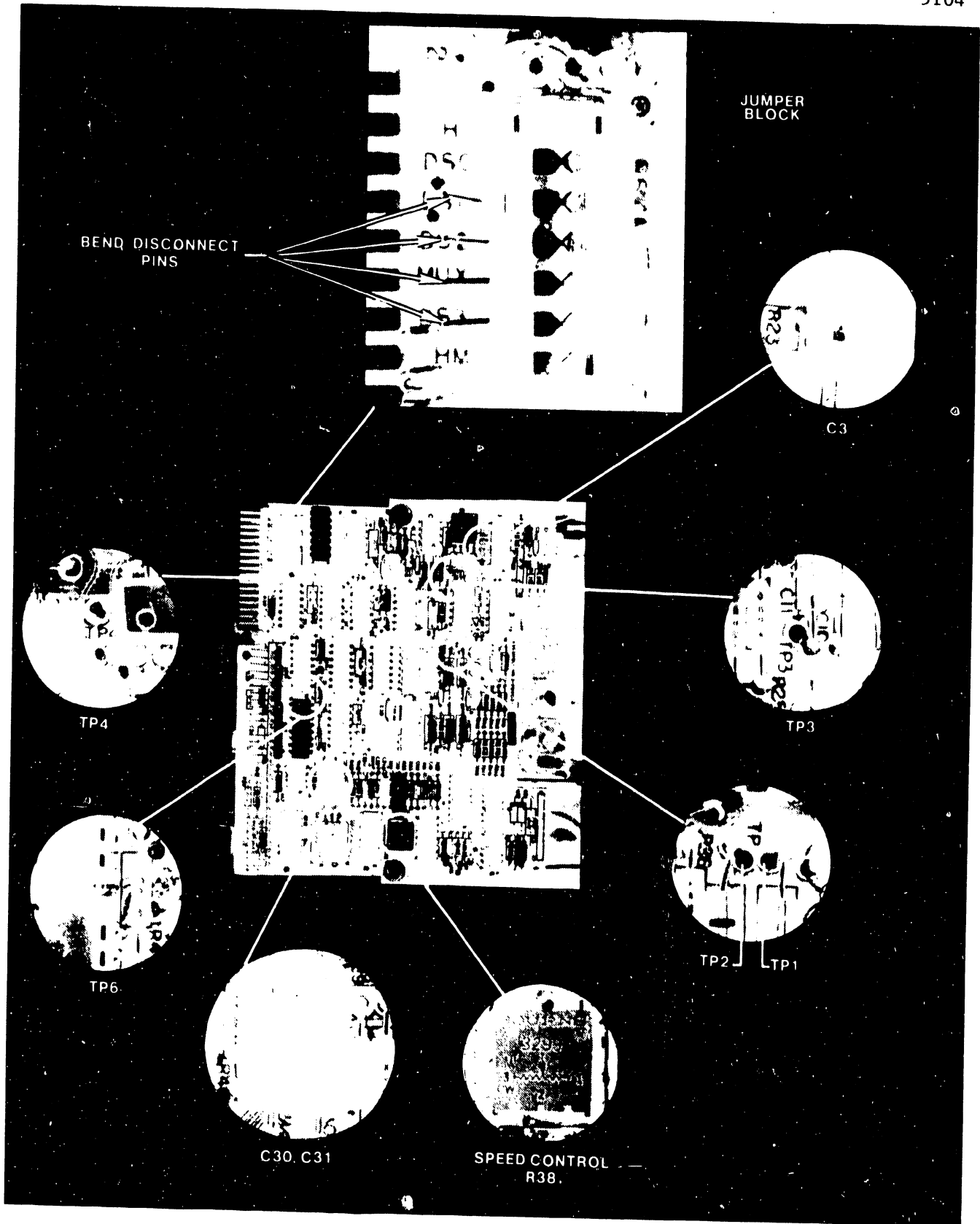

FIGURE 5-24 MPI DISK DRIVE PC BOARD TEST LOCATIONS

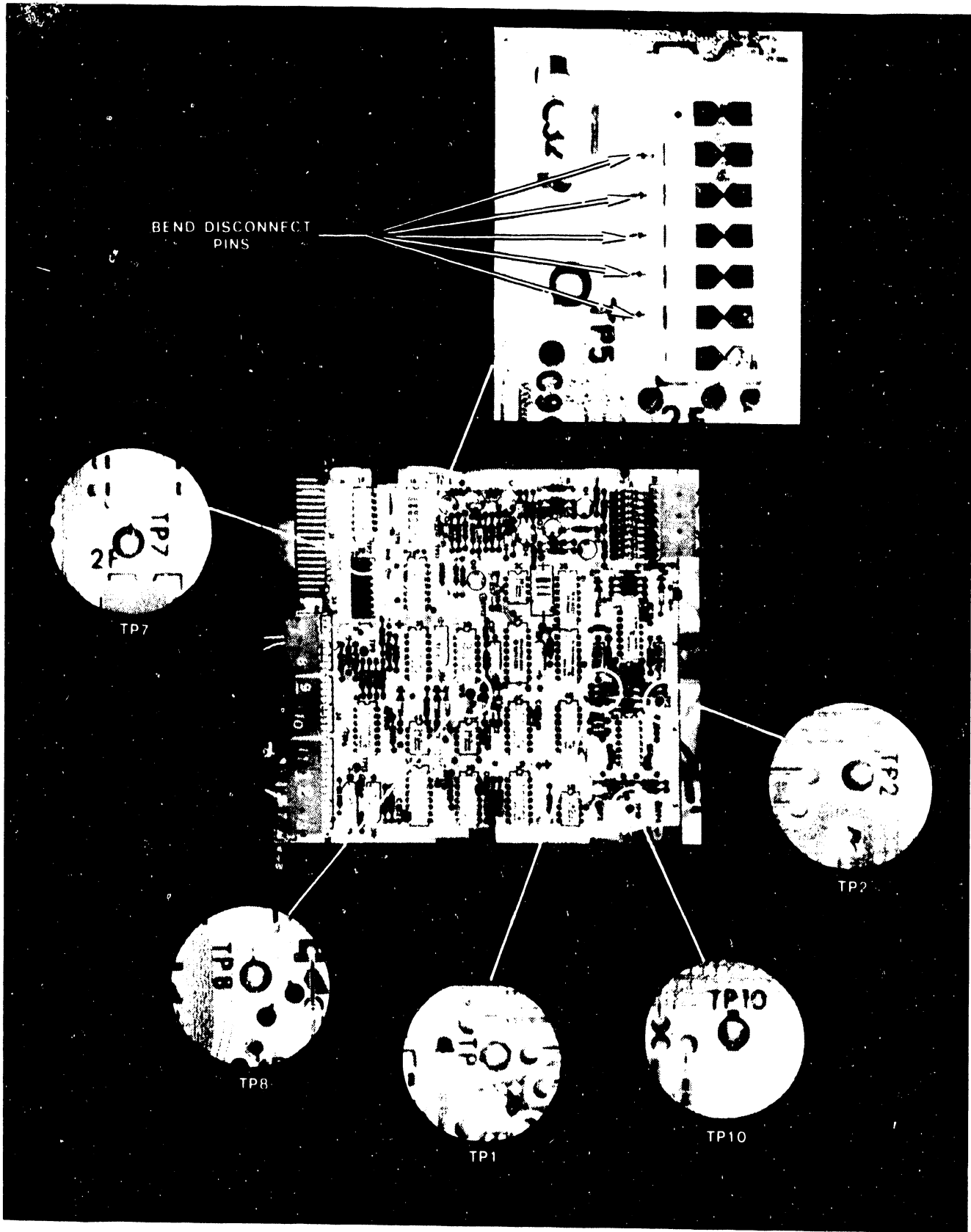

FIGURE 5-25 TANDON DISK DRIVE PC BOARD TEST LOCATIONS (1 OF 2)

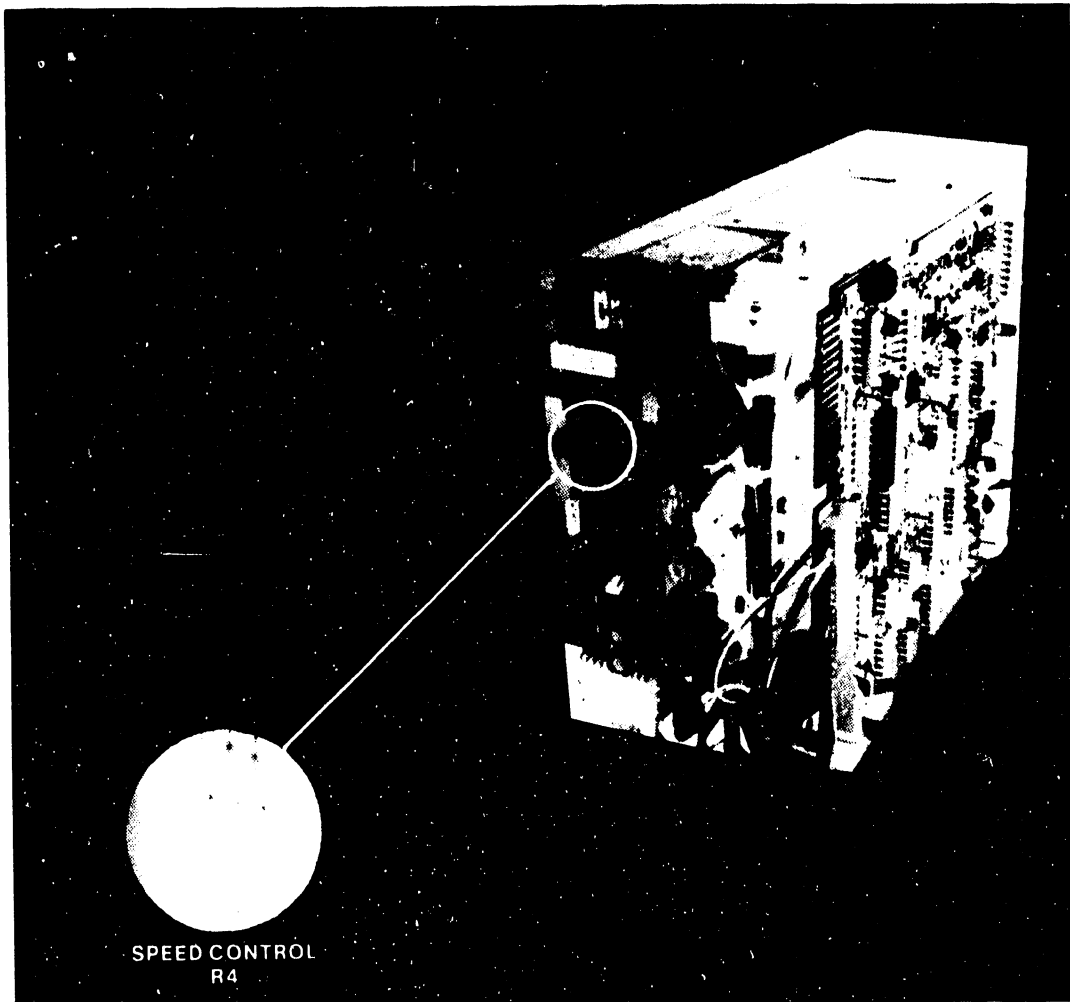
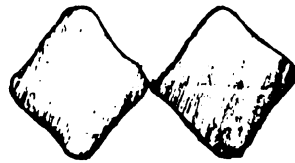

FIGURE 5-25 TANDON DISK DRIVE PC BOARD TEST LOCATIONS (2 OF 2)



**EQUAL AMPLITUDE
(ON TRACK 16)**



**LEFT 80% OF RIGHT
(-1 MIL OFF TRACK, TOWARD 15)**

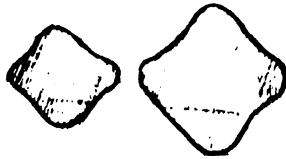

**LEFT 60% OF RIGHT
(-2 MIL OFF TRACK, TOWARD 15)**

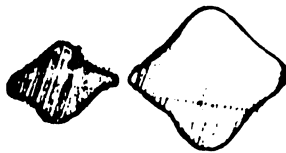

**LEFT 40% OF RIGHT
(-3 MIL OFF TRACK, TOWARD 15)**



**RIGHT 80% OF LEFT
(+1 MIL OFF TRACK, TOWARD 17)**



**RIGHT 60% OF LEFT
(+2 MIL OFF TRACK, TOWARD 17)**

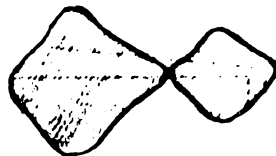

**RIGHT 40% OF LEFT
(+3 MIL OFF TRACK, TOWARD 17)**

FIGURE 5-26 TRACK SIGNALS

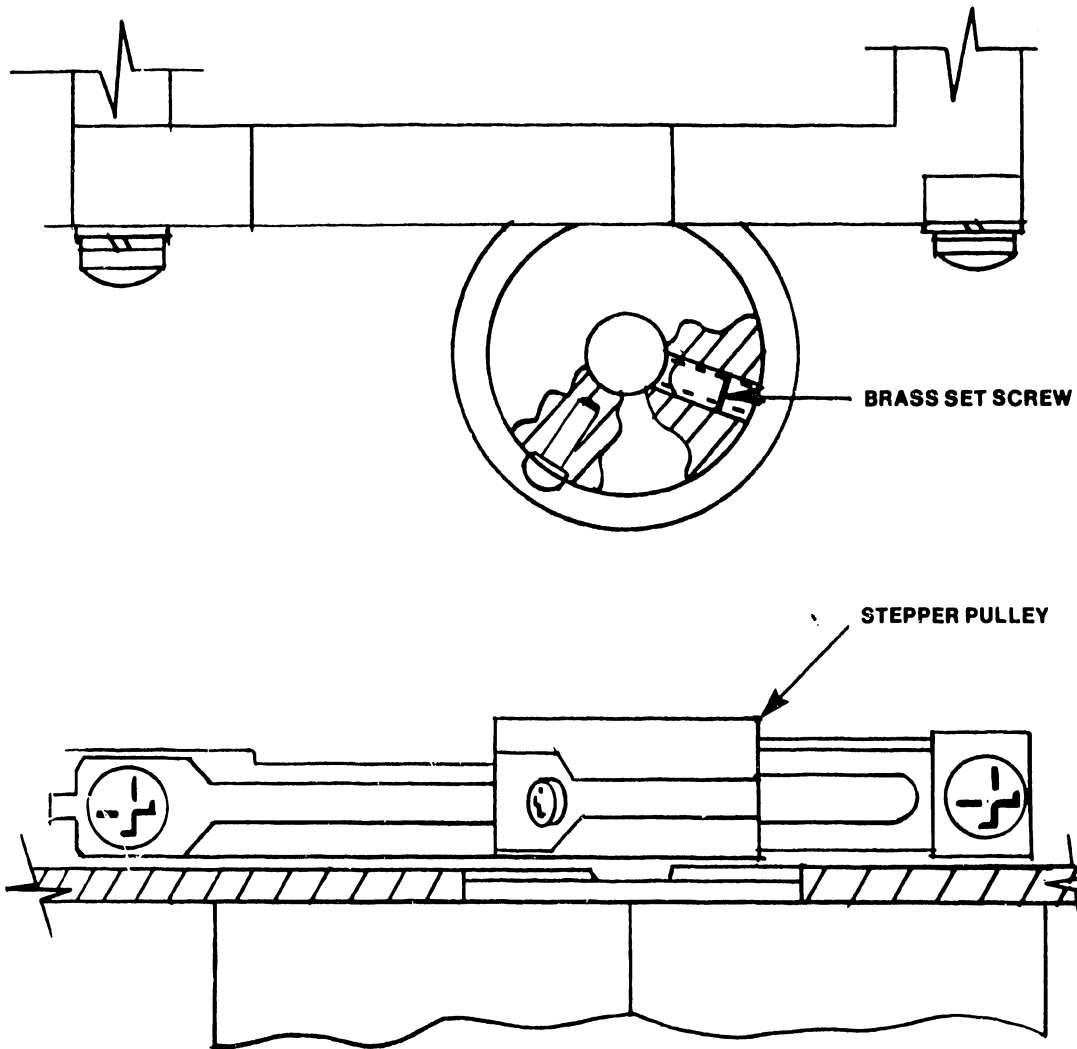
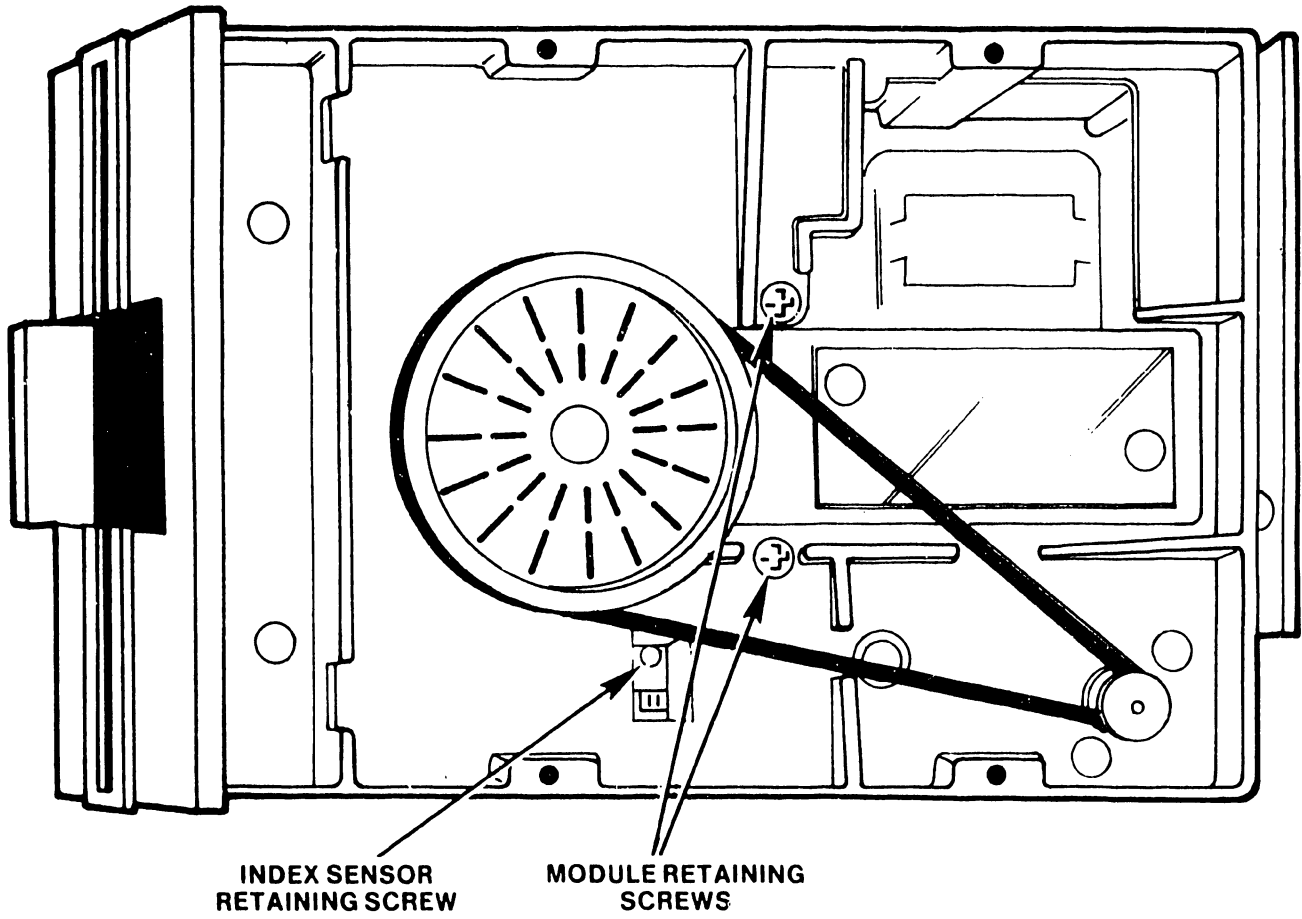

FIGURE 5-27 STEPPER PULLEY/BAND ASSEMBLY



**FIGURE 5-28 RADIAL ALIGNMENT AND INDEX SENSOR ADJUST
(TANDON DISK DRIVE)**

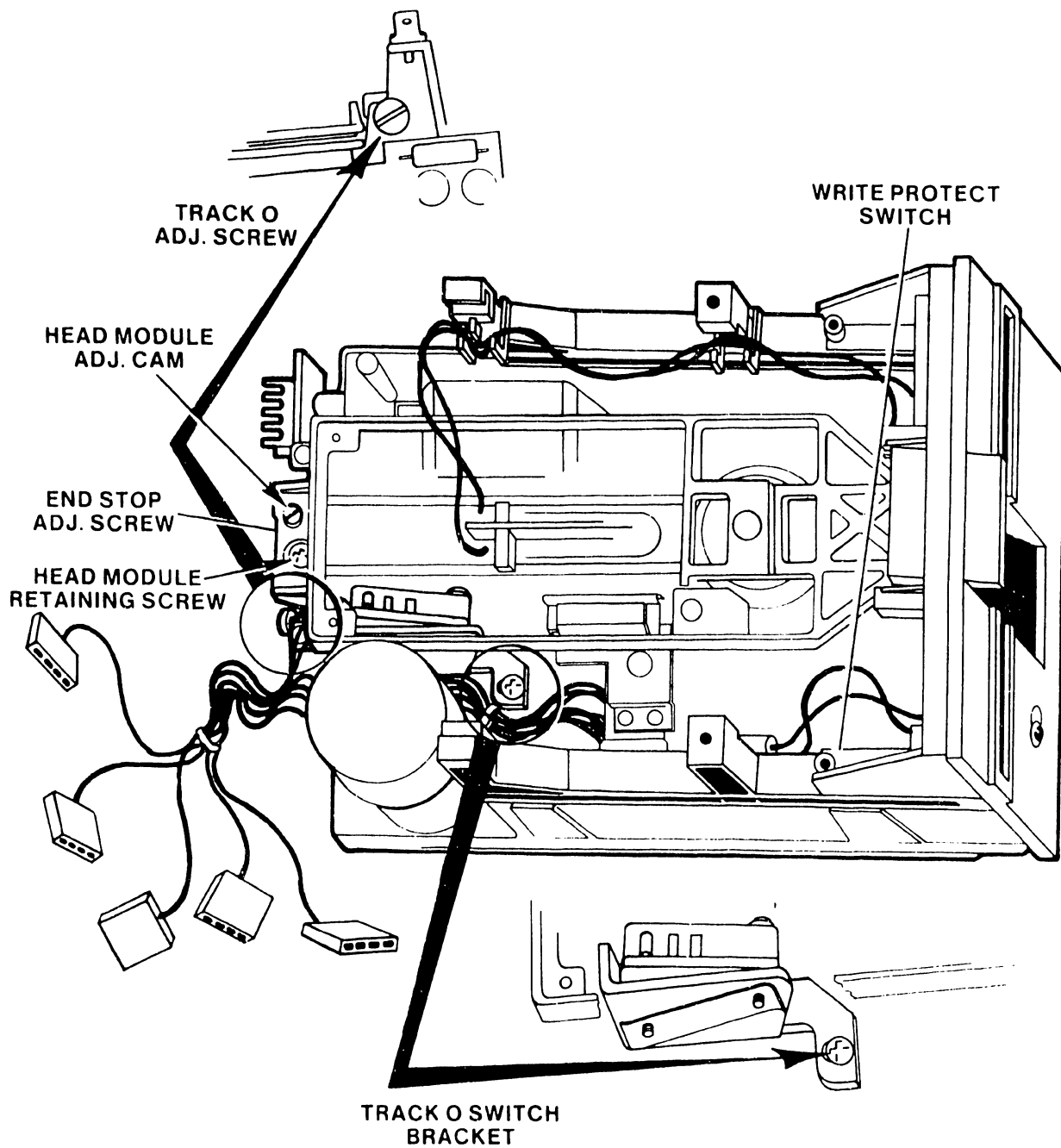

FIGURE 5-29 TRACK 00 ADJUST (TANDON DISK DRIVE)

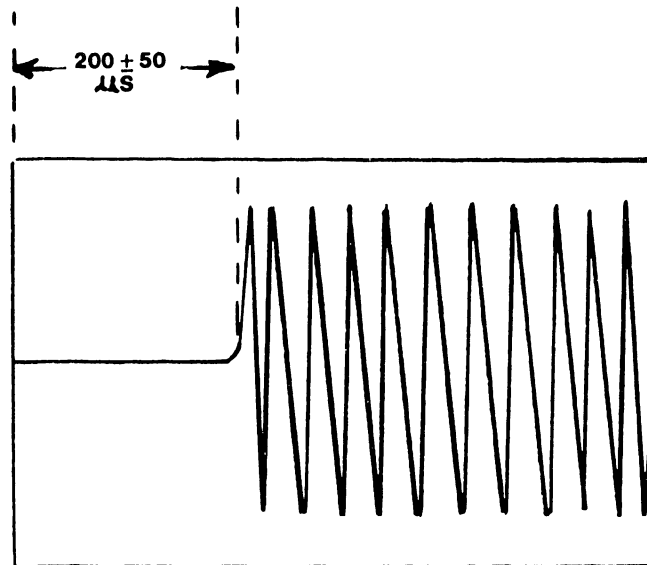

FIGURE 5-30 INDEX-TO-DATA ALIGNMENT PATTERN

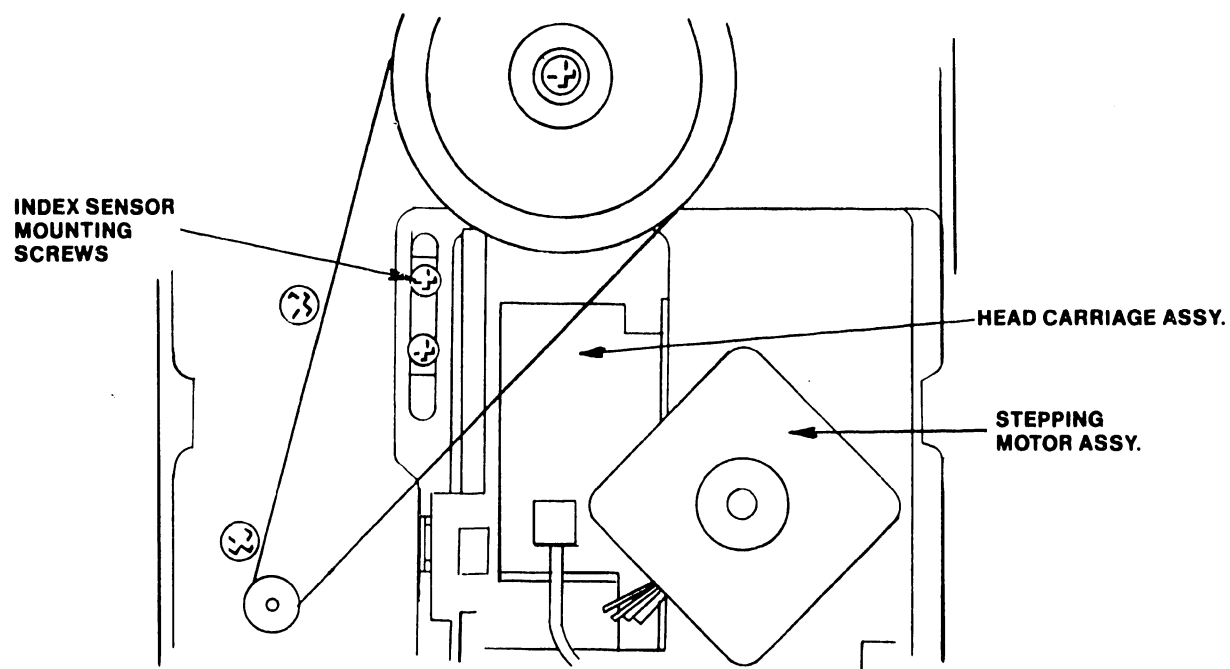

FIGURE 5-31 INDEX SENSOR MOUNTING SCREWS

MPI Track 00 Sensor -

1. Verify the radial-track alignment (see paragraph 5.2.1.2.1).
2. Connect channel A probe to connector J4-12 (blue connector); set scope trigger to INTERNAL/AUTO; put ground probe to ground end of C30/C31 (see Figure 5-25).
3. Check the signal at J4-12 for logic 0 at tracks 0,1, and 2 (keys 0, 1, and 2).
4. Check the signal at J4-12 for logic 1 at track 3 (key 3).
5. If voltages are not correct, go to paragraph 5.2.1.2.6.

Tandon Track 00 Switch -

1. Select track 00 (key 0)
2. At the PCB, check for logic 0 at TP8. If TP8 is logic 1, go to the (Tandon) adjustment of paragraph 5.2.1.2.6.
3. Press key 1 to seek track 1; If TP8 fails to go to logic 1, go to the (Tandon) adjustment of paragraph 5.2.1.2.6.

5.2.1.2.6 Track 00 Sensor/Switch Adjustment

MPI: Track 00 Sensor -

1. Remove head connectors (brown) from printed circuit board.
2. Remove printed circuit from mounting (two screws).
3. Remove shield cover.
4. Set-up is in step 2 of paragraph 5.2.1.2.5.
5. Loosen two track 00 sensor mounting screws (top rear of disk drive, see Figure 5-32).
6. Adjust sensor to obtain a logic 0 at J4-12 through track positions 00, 01, and 02.
7. Step sensor to track 03 (key 3) and adjust to obtain a logic 1.

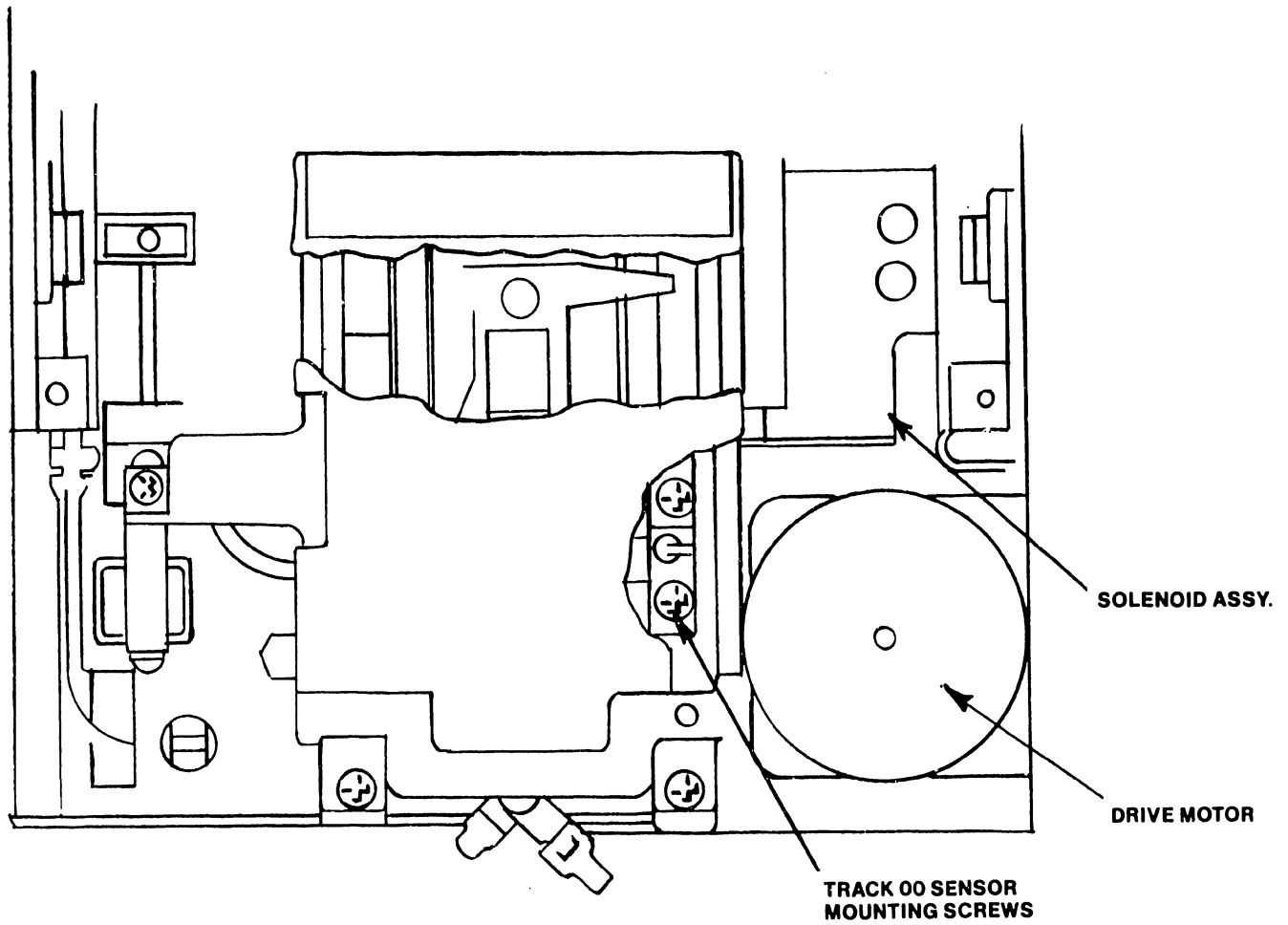

FIGURE 5-32 TRACK 00 SENSOR MOUNTING SCREWS

Tandon: Track 00 Switch -

1. Turn off power and remove alignment diskette. Remove PCB but do not remove connectors.
2. Loosen retaining screw on the base of the track 00 bracket (Figure 5-29); retighten slightly to provide some friction on the bracket. Turn track 00 adjustment screw CCW to maximum.
3. Repower system (with minidiskette inserted) and select track 00. Rotate track 00 adjustment screw clockwise until the switch clicks. Then rotate screw clockwise (same direction) exactly one-half turn.
4. Tighten retaining screw.

5.2.1.2.7 Speed Control Check

Both types of disk drive are marked for stroboscopic observation under fluorescent lighting. The markings appear motionless at the proper speed. A small amount of strobe creep is permissible however,.

1. Remove mounting bracket.
2. Turn on the system.
3. Insert a minidiskette and close door.
4. Turn the drive on its side and observe the stroboscopic effect on the timing disk. If trace stability is unacceptable, go to paragraph 5.2.1.2.8.

5.2.1.2.8 Speed Control Adjustment

1. Perform setup of paragraph 5.2.1.2.7.
2. For a stable pattern, go to the PC assembly and adjust:

R38 - MPI
R4 on servo PCA - Tandon

5.2.1.2.9 Track 00 End-S op Check

1. Verify radial track alignment (paragraph 5.2.1.2.1).
2. Verify track 00 sensor alignment (paragraph 5.2.1.2.5).
3. Command seek to track 00 (key 0).

4. MPI Drive: Check that a maximum track seek (key 6) and a return to track 00 moves the carriage to within 0.010 inch/0.0254 cm of the end stop. If the carriage is not within specification, go to paragraph 5.2.1.2.10.

Tandon: The track 00 End-Stop Adjustment (paragraph 5.2.1.2.10) should be done following a Radial-Track adjustment or when the carriage seeks to a track lower than track 00. A 125 kHz continuous pattern should be visible at TP1 and TP2 with track 00 selected.

5.2.1.2.10 Track 00 End-Stop Adjustment

MPI Drive:

1. Adjust set screw on the left-hand boss in the rear of the drive to approximately 0.010 inch/0.0254 cm from the end of the carriage (approximately one-half revolution of the set screw).
2. Verify adjustment by commanding a maximum track seek (key 6) and a return to track 00 (key 0). Ensure that carriage does not hit the end stop.

Tandon Drive:

1. Ensure radial-track alignment set-up (paragraph 5.2.1.2.1); select track 00.
2. Turn track 00 stop screw (Figure 5-28) CCW two turns (.050" Allen wrench).
3. Turn the stop screw CW until the output amplitude shown on the dual-channel scope begins to decrease.
4. Turn the stop screw CCW until the amplitude stops increasing.
5. Turn the stop screw CCW an additional 1/8 turn.

5.2.1.2.11 Neoprene Drive Belt

The neoprene drive belt tension is not critical; it does not need adjustment.

5.2.1.2.12 Write Protect Switch (Tandon drive only)

1. Insert a non-write protected minidiskette halfway into the drive.

2. Ensure that the switch is actuated. TP9 should be at logic 1 (+4V).
3. Insert minidiskette fully against the diskette back stop and close front latch. Ensure that switch is deactivated. TP9 should go to logic 0.
4. To adjust switch (Figure 5-29) Loosen retaining screw, remove switch assembly, and set switch either higher or lower as required.

5.2.1.2.13 PLL Check and Adjustment (VCO)

For a check of both Model 5503 and 5504/5524 VCO adjustment, via the system diagnostic disk, refer to Diagnostics, Chapter 8. The following steps, where necessary, distinguish between models.

1. Turn system power OFF.
2. Remove console right side. Reconnect keyboard and monitor cables.
3. 5503 only: Remove printer PCA (see paragraph 5.2.2).
4. 5503: Ground pin 24 (VCO sync) of L27 (UPD765) on CPU/disk PCA.
5504/5524: Ground pin 55 of ZIF connector.
5. Put vertical input lead of scope on CPU PCA.
5503: TP2
5504/5524: TP3 (top of PCA)
6. Put scope ground lead to chassis.
7. Set Horizontal Sweep on scope to 0.2 microseconds.
8. Turn system power ON. Allow 20-minute warmup period (minimum) before attempting adjustment.
9. Adjust scope to obtain a 1.02-microsecond cycle time.
10. If the 1-microsecond cycle time is not present on the scope, adjust pot on the CPU PCA.
5503: Pot located lower left corner of PCA.
5504/5524: R52 - upper right corner - accessible from the back of the unit.

If unable to obtain waveform by adjusting the pot, replace CPU board.

11. Turn power OFF.
12. Remove grounded pins. 5503: Pin 24 of L27 on CPU/disk PCA.
5504/5524. ZIF connector pin 55.
13. Remove scope signal and ground probes.
14. 5503 only: Replace printer PCA.
15. Replace right-side cover.
16. Reload operating system software, and verify operation.

5.2.1.3 Video Monitor

CAUTION

No work should be attempted on an exposed Video Display Chassis by anyone not familiar with servicing procedures and precautions. Use care when handling the cathode ray tube.

SAFETY WARNING

When working inside any electronic chassis, use only one hand. This minimizes the possibility of the putting of one hand on chassis or ground and the other on a high voltage. Avoid prolonged exposure at close range to unshielded areas of the cathode ray tube. Injury may result from exposure to X-Ray radiation.

Adjustments for focus, width, horizontal hold, phasing, vertical size, vertical linerity, and vertical hold are accessible when the front panel is removed from the monitor pedestal (see Figure 5-33). All other controls are factory adjustments.

- 5.2.1.3.1 Set-Up Screen: Either use diagnostic, Chapter 8 Display & Keyboard, CRT Adjustment Test or create a document to display a full screen (80 by 24) filled with alternating characters "HO".
- 5.2.1.3.2 Horizontal and Vertical Hold Adjustments: Set both Horizontal hold (R33) and Vertical hold (R15) to middle of stable display range.
- 5.2.1.3.3 Vertical Height Adjustment: Adjust the vertical size (R24) for a vertical height of 5.75 inches, (14.6 cm) on the 12" display. (Use a standard or metric scale).

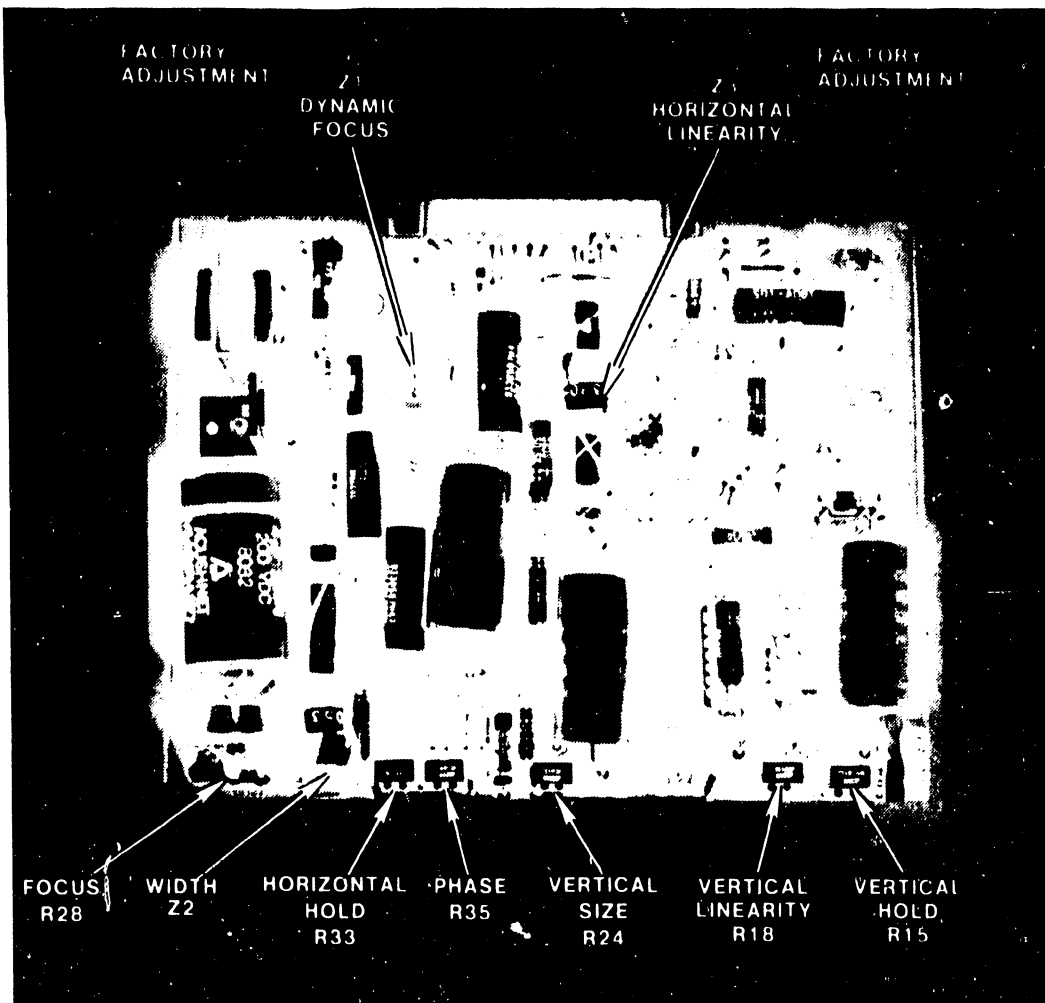

FIGURE 5-33 ELECTRONICS BOARD FOR 12-INCH DISPLAY MONITOR

- 5.2.1.3.4 Vertical Linearity Adjustment: Adjust the vertical linearity (R18) for character rows of equal height. Repeat 5.2.1.3.3 and 5.2.1.3.4 until both requirements are met.
- 5.2.1.3.5 Screen Width Adjustment: Adjust the width coil (Z2) for 7.75 inches (19.7 cm) of horizontal deflection on the 12" display. (Use standard or metric scale.)
- 5.2.1.3.6 Phase Adjustment: Adjust the phase adjustment (R35) for characters centered horizontal on the raster. (Turn the brightness up sufficiently to observe the raster frame.)
- 5.2.1.3.7 Focus Adjustment: Adjust the focus (R28) for the best overall screen display.

5.2.1.4 Power Supply Voltage Adjustments

Power supply voltage adjustments may be made only to the +12V and +5V supplies. The +12V and +5V adjustments are on the regulator board in the power supply drawer (see Figure 5-34). The power supply for Model 5504 Wangwriters must have a power draw of at least 10% of its rated capability (approximately 32 Watts) during test. Maintenance of normal system connections satisfies this requirement.

1. Turn power off and remove sides of the printer cabinet.
2. Remove the two screws on each side of the power supply and slide power supply to the rear. See paragraph 5.2.2.
3. Fasten the negative lead of the voltmeter to ground (see Figure 5-34).
4. Fasten positive lead of the voltmeter to the respective check points as shown in Figure 5-34.
5. Turn system ON. Check/adjust voltages as indicated in Figure 5-34. If the voltages are not within the indicated limits, adjust R1 as close as possible to the center of the indicated limits. If adjustment is not possible, replace the regulator PCA and heat sink sub-assembly. If this fails to correct the problem, replace power supply (see paragraph 5.2.2).

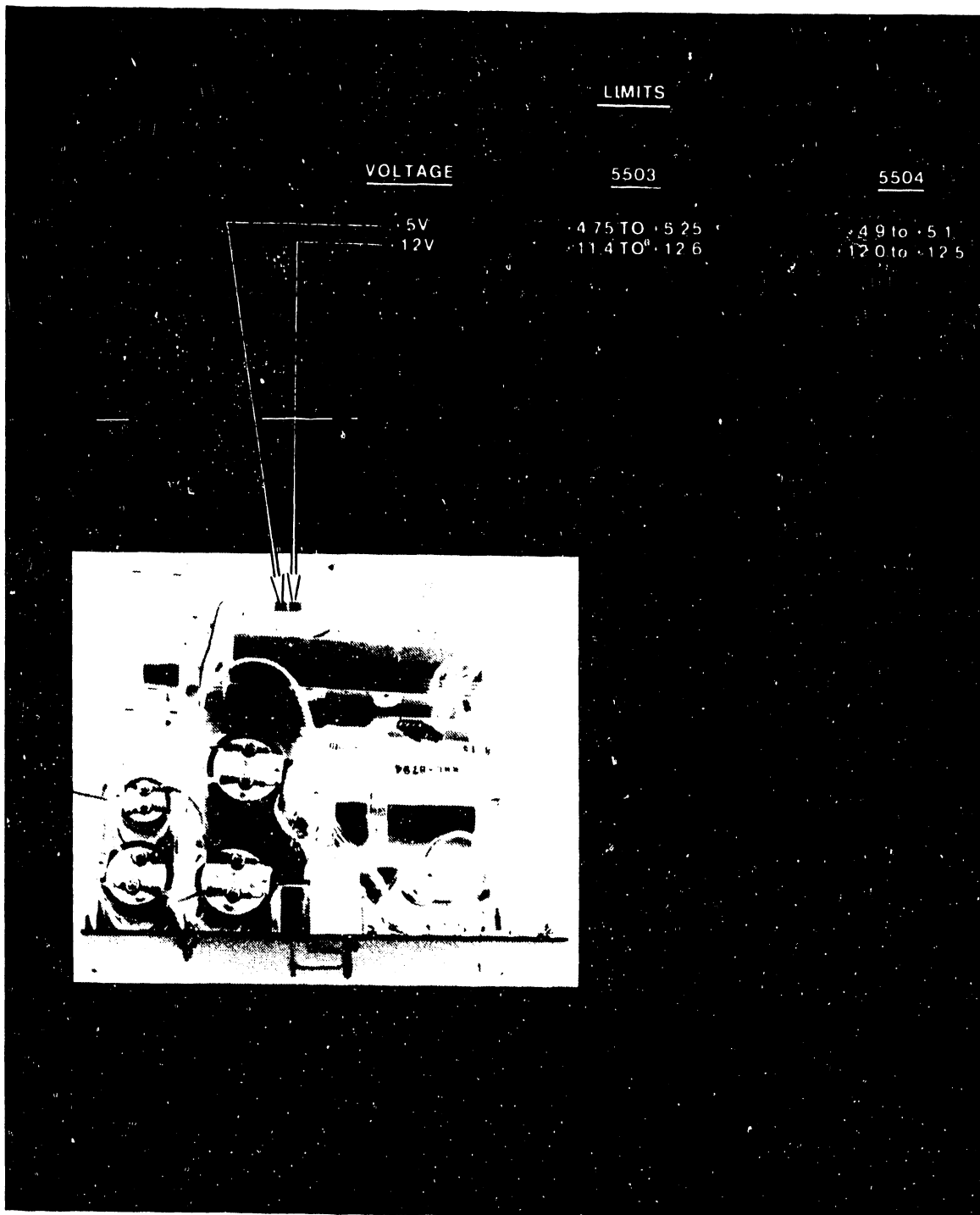
**FIGURE 5-34 POWER SUPPLY VOLTAGE ADJUSTMENTS**

5.2.2 REMOVAL AND REPLACEMENT

This paragraph contains procedures and illustrations for removal and replacement of equipment.

5.2.2.1 Side Covers Removal

1. Remove both the video and keyboard cables from the back of the console. (see Figure 5-35).
2. Lift the printer's transparent protective hood.
3. Lift right and left side flaps.
4. Loosen the two large screws (1) on the inside of both sides of the printer compartment (see Figure 5-36) until the sides are free.
5. Slide the side covers off.

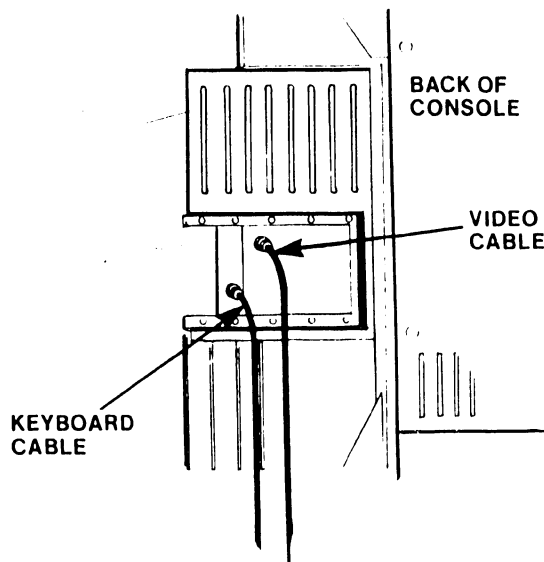

**FIGURE 5-35
KEYBOARD & VIDEO CABLES**

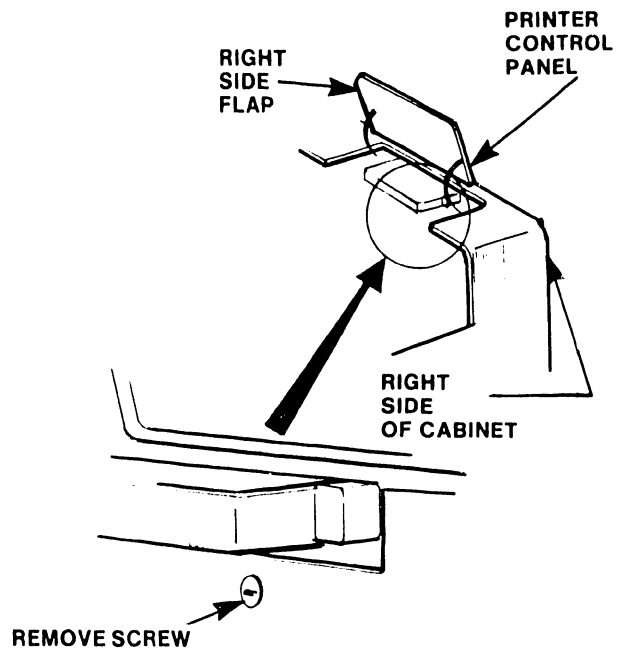

**FIGURE 5-36
RIGHT SIDE COVER REMOVAL**

5.2.2.2 Printer Removal

1. Remove the side covers as described in paragraph 5.2.2.1.
2. On the outside of the frame, remove the two screws that hold the printer's control panel.
3. Disconnect the flex cable, motor power cable, paper-feed motor cable, and sensor cable from the 7776 -A PCA (see Figure 5-38).
4. Release the four printer legs from their shock mount by pulling up on each corner of the printer unit, one at a time.

CAUTION
DO NOT PULL ON CARRIAGE RAILS

5. Lift the printer out of the console.

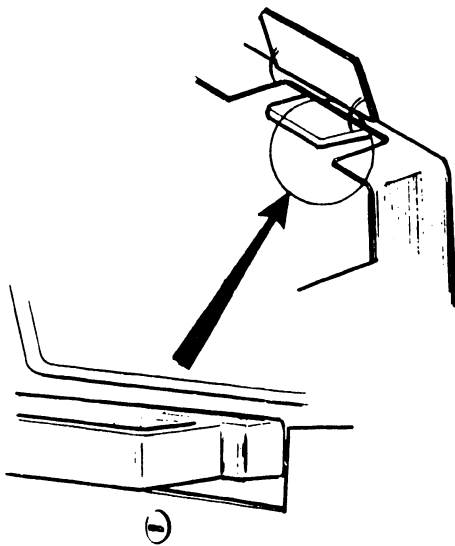

**FIGURE 5-37
CONTROL PANEL REMOVAL**

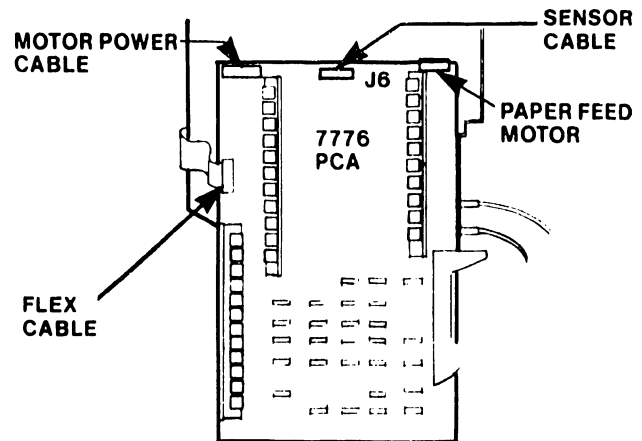

**FIGURE 5-38
FLEX AND SENSOR CABLES**

5.2.2.3 CPU, Printer and CRT/MEM PCA Removal

NOTE

Do not solder to pins on PCA boards.
The pins are press fitted - not soldered.

1. Remove the right side cover. Refer to paragraph 5.2.2.1.
2. Remove the six (6) mounting screws (on the rear side of the PCAs) that hold the metal brackets to the unit (see Figure 5-39).
3. Remove the three (3) nuts (in front of the PCA's) that hold the boards to PCA support rods (see Figure 5-40).

Fig. 5-39 Removal of Mounting Screws
(orig 7-5)

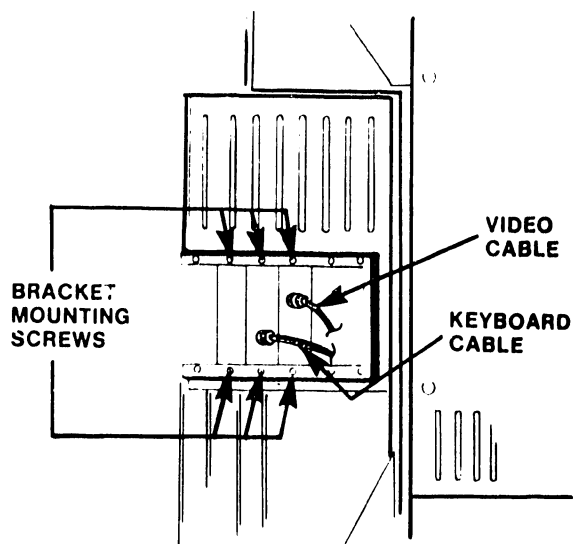

FIGURE 5 - 39
REMOVAL OF MOUNTING SCREWS

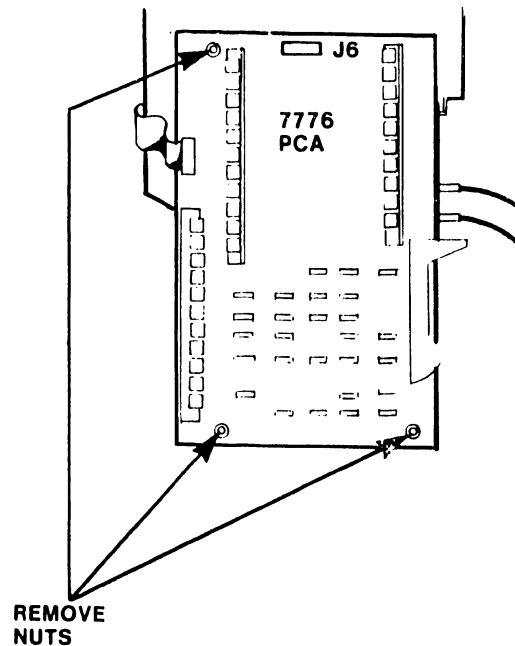
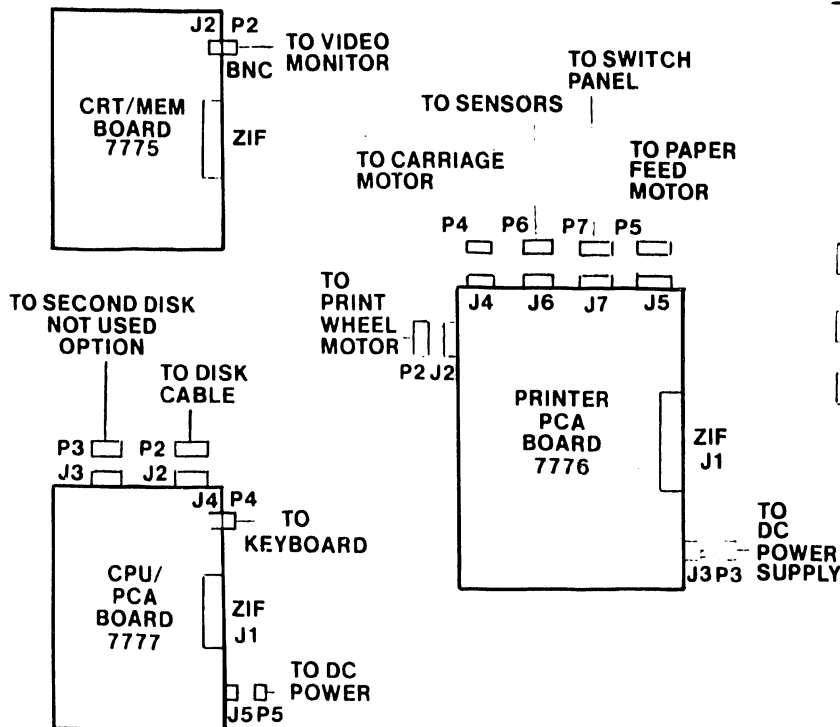

FIGURE 5 - 40
BOARD-TO-SUPPORT ROD NUTS

NOTE

The printer PCA is on the outside of cage, the CPU PCA is in the middle, and the CRT/-Memory is on the inside. Note which connectors go where as you disconnect them. Be careful to adequately seat of all connectors, especially the ZIF connectors.

4. Disconnect cables (see Figure 5-41 and Figure 5-42). To release the ZIF connectors, pull the levers on the PCA behind the PCA being removed.
5. Remove PCAs.



**FIGURE 5-41
PCA CONNECTORS**

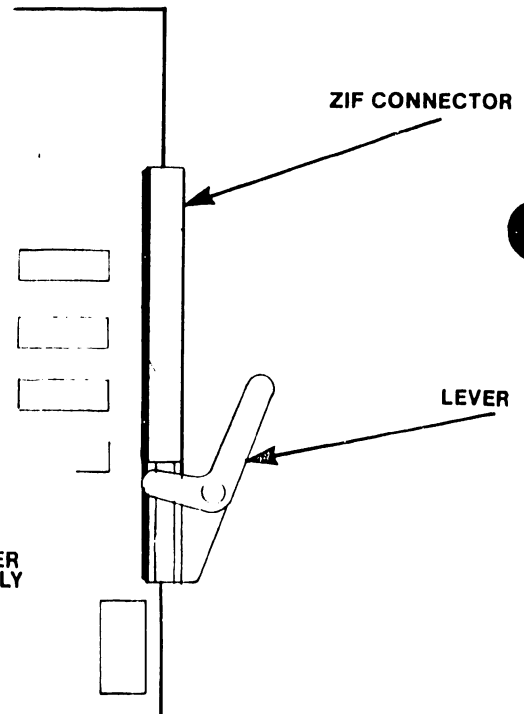

**FIGURE 5-42
ZIF CONNECTOR**

5.2.2.4 Disk Drive Removal

1. Remove left side cover as described in paragraph 5.2.2.1.
2. Disconnect both ribbon and power cables going to the disk drive (see Figure 5-43).
3. Loosen the four mounting screws on the drive (see Figure 5-44). Slide the drive so that the screws line up with the large holes at the ends of the slots on the mounting bracket.
4. Remove only the upper right screw. Remove disk drive.

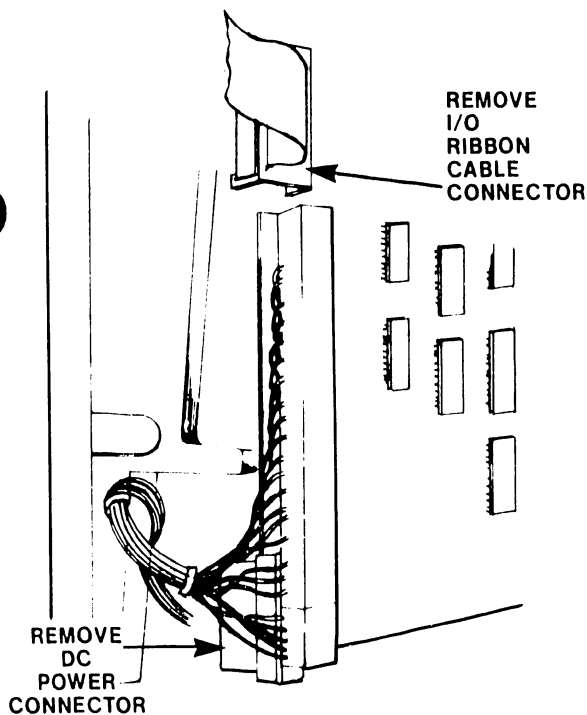

**FIGURE 5-43
POWER AND RIBBON CABLES**

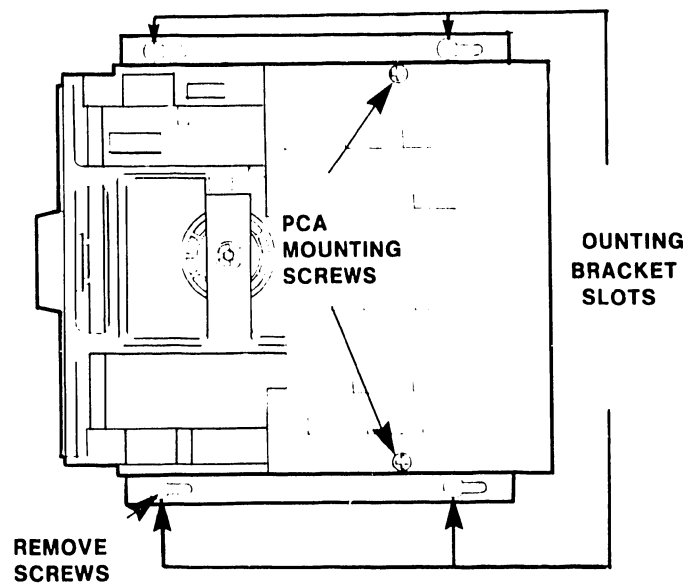

**FIGURE 5-44
MOUNTING BRACKET SLOTS**

5.2.2.5 Print Head Assembly

1. Release the locking tab securing the connector, and disconnect the head cable from the flex cable (see Figure 5-45).
2. Release the spring holding the carriage base plate to front shaft bearing at copy control lever cutout.
3. Pull print head assembly forward, and remove the four screws holding the assembly to the rear shaft bearing assembly. (Be careful not to lose the shim between the carriage plate and bearing. See Figure 5-46.)
4. Lift head assembly from the printer unit.

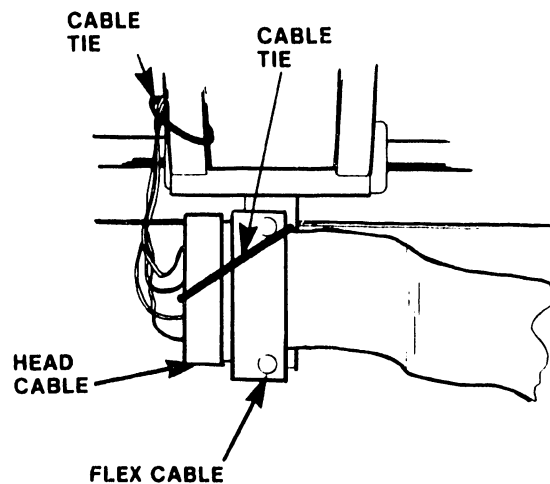

FIGURE 5-45 HEAD AND FLEX CABLE

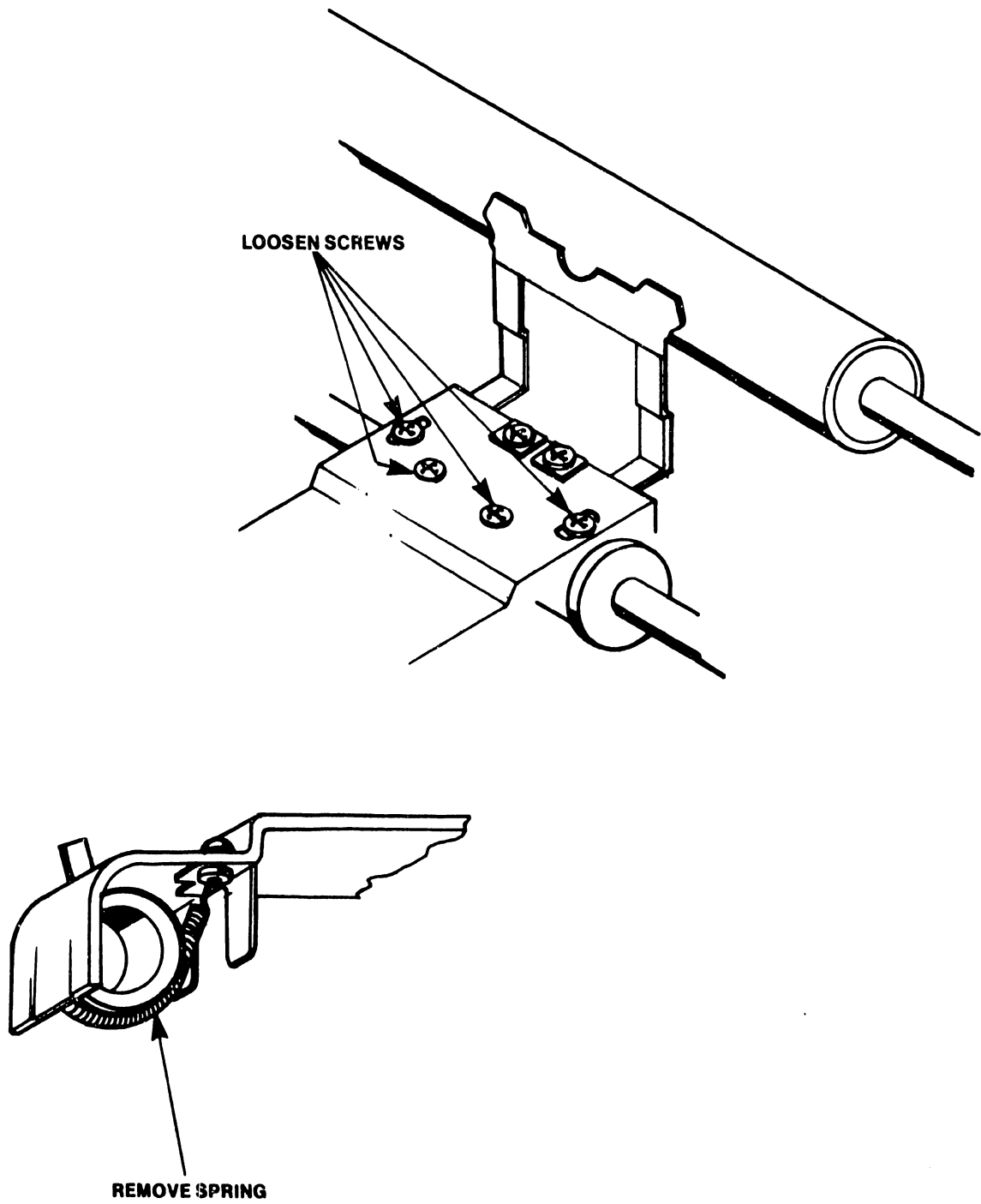
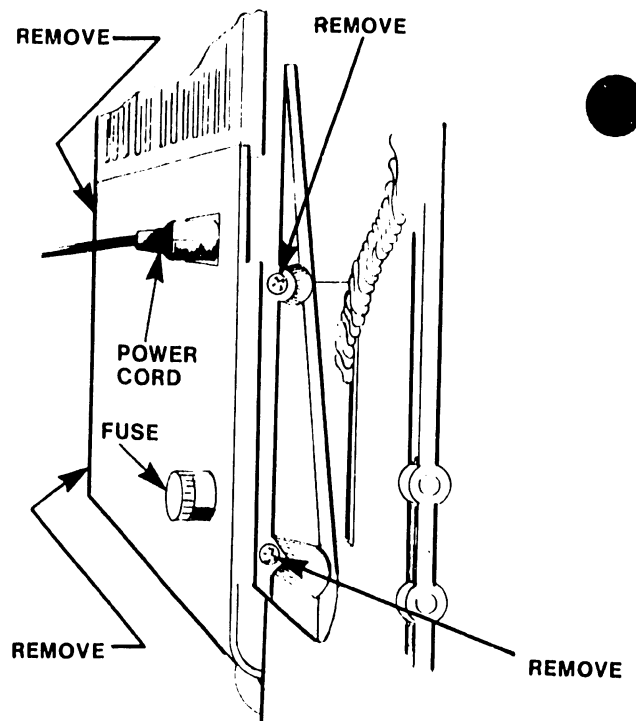

FIGURE 5-46 HEAD ASSEMBLY BASE PLATE MOUNTING

5.2.2.6 Power Supply

1. Remove AC power cord and cable to CRT.
2. Remove side covers.
3. Remove the two screws on each side of the power supply (see Figure 5-47).
4. Remove cables on the printer driver board (P3 on right side of PCA).
5. Remove the power cable to the CPU board (P5 on right side of PCA).
6. Remove the power-to-disk drive cable (P2 on right hand side).
7. Slide the power-supply drawer out of the rear of the cabinet.



**FIGURE 5-47
POWER SUPPLY REMOVAL**

5.2.2.7 CRT Cover Removal

1. To remove the top cover of the CRT, remove the two screws (shown in Figure 5-48) in the back of the monitor.
2. Slide the cover back and then lift off.

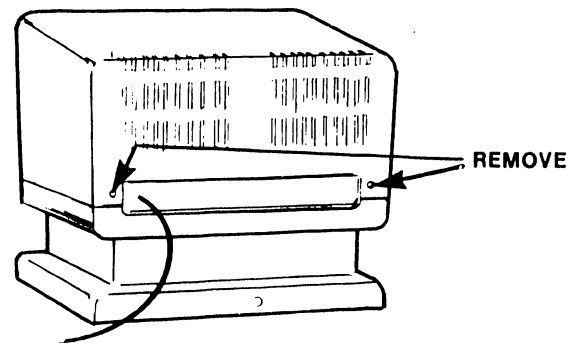

**FIGURE 5-48
CRT COVER REMOVAL**

5.2.2.8 Carriage Removal

1. Remove the side covers (paragraph 5.2.2.1).
2. Remove the printer from the stand (paragraph 5.2.2.2).
3. Loosen and remove the carriage cords.
4. Remove the carriage-rod hold-downs by removing the screws that hold them to the side frame (see Figure 5-49).

NOTE

If a new carriage comes with a cable, omit step 5.

5. Remove the flex cable by removing the two screws on the end of the cable that mounts to the carriage (see Figure 5-50). Also remove tie down.
6. Slide the carriage off the rods.

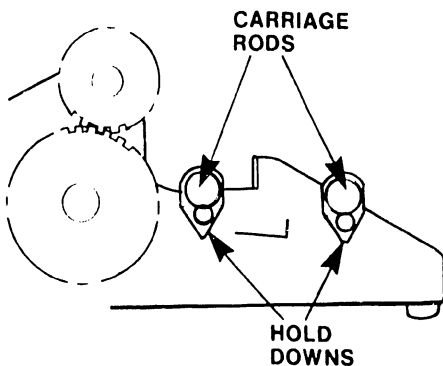

**FIGURE 5-49
CARRIAGE RODS HOLD DOWNS**

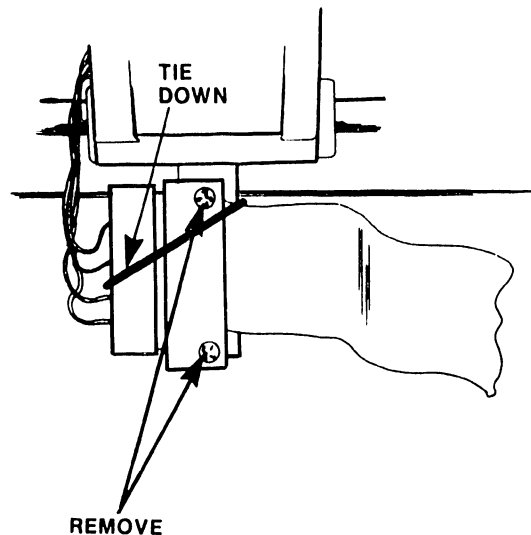

**FIGURE 5-50
CARRIAGE FLEXIBLE CABLE**

5.2.2.9 Cord Replacement

1. Remove the side covers of the print stand (paragraph 5.2.2.1).
2. Remove the printer (paragraph 5.2.2.2).
3. Loosen the cord tension by removing the screw, (1) of Figure 5-51.
4. Put the ball end of the cord in the bottom hole of the carriage hub, (2).

NOTE

A spring hook is helpful in handling the cords.

5. With the loop end of the cord, feed the cord around the right-hand pulley (3).
6. Push the loop end of the cord through the hole in the right-hand side frame, and fasten the end with the holding pin (4).
7. With the spring hook, loop the cord around the top groove of carriage pulley. Position the carriage about two inches from the left-side frame (5).
8. Turn the hub clockwise to get a couple of loops on the hub. Hold the hub tight, and pull the cord out at the point between the hub and the pulley. Slide the carriage to the right side of the printer (within about an inch of the right side). This allows room to wind up the rest of the cord without interference from the carriage (6).
9. Put the ball end of the second cord in the top hole of the hub. Wrap the cord clockwise around the hub two full turns with the cord coming off the front of the hub (7).
10. Take the loop end of the cord and feed it around the left pulley (8).
11. Loop the cord, with the spring hook, around the bottom groove of the carriage pulley (9).
12. Put the loop end of the cord through the left-side frame and insert the holding pin (10).
13. Tighten the cord tension. Alternately turn both right and left tension-adjusting screws to divide the slack evenly. Fine-tune the adjustment as directed in paragraph 5.2.1.1.13.
14. Replace printer.
15. Replace side covers.

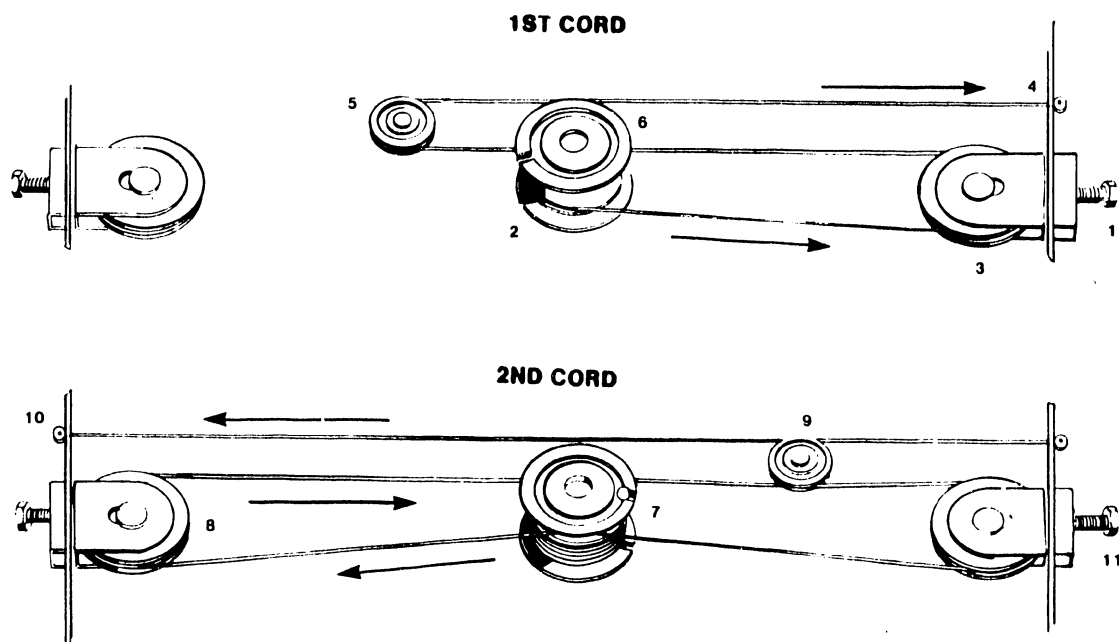
**FIGURE 5-51 CORD REPLACEMENT**

5.2.2.10 Photo Sensor

Unscrew all 5 photo sensors from the printer, and remove their leads from the connectors. Right and left carriage sensor leads may be cut under the printer base, and the soldered to reconnect.

5.2.2.11 Paper Feed Tray Removal

Loosen the two thumb screws in the back of the paper-feed tray to remove it from the printer.

5.2.2.12 Platen Assembly Removal

Release the latches on each side of the platen assembly and lift the platen up and out.

5.2.2.13 System Keyboard Removal

The CRT keyboard is removed by unscrewing the three screws just below the function keys under the plastic logo strip. This allows removing the top cover of the keyboard. Then remove the four keyboard-mounting screws and the connector that plugs into the keyboard.

5.2.2.14 Card Guide Removal

The card guide is removed by removing the two screws on the mounting bracket.

5.2.2.15 Hammer Removal

CAUTION

The hammer is spring loaded and can pop out unexpectedly.

To remove the hammer, remove one of the two hammer bracket mounting screws; loosen the other, and tip up one end of the bracket. Once this is done, the hammer slides out of the housing.

5.2.2.16 Print Wheel Removal

Print wheel removal is done by tilting the ribbon platform back. This lifts the ribbon automatically. Now pull on the print wheel hub. It lifts off easily.

5.2.2.17 CRT PCA Removal

1. Remove CRT cover as specified in paragraph 5.2.2.7.
2. Remove PCA by pulling it out of its socket.

CHAPTER

6

SYSTEM

SCHE-

MATICS

THE SCHEMATICS, WHEN AVAILABLE, ARE ON THE LAST FICHE IN THIS SET.

CHAPTER

7

ILLUSTRATED

PARTS

BREAKDOWN

CHAPTER 7

ILLUSTRATED PARTS BREAKDOWN

This chapter contains illustrations, nomenclature, and part numbers of the principal assemblies and component parts of the Wangwriter Models 5503 and 5504. Principal assemblies are:

CRT Assembly	Figure 7-1
Keyboard Assembly	Figure 7-2
Left Side Assembly - 5503	Figure 7-3A
Left Side Assembly - 5503A/5503D/5504S/5504D	Figure 7-3B
Right Side Assembly - 5503/5503A/5503D	Figure 7-4A
Right Side Assembly - 5504S/5504D	Figure 7-4B
Printer Mechanism Assembly 279-9000-10 (5503)	Figure 7-5A
Printer Mechanism Assembly 279-9002-10 (5504)	Figure 7-5B
Head Assembly 279-9000-22 (5503)	Figure 7-6
Motor Mount Assembly	Figure 7-7
Daisy Damper Assembly	Figure 7-8
Power Supply Assembly 279-9000-32 (5503)	Figure 7-9A
Power Supply Assembly 279-9000 62/63 (5504)	Figure 7-9B

NOTE: Part numbers accompanied by an asterisk (*) are recommended spares. All other parts should be ordered only as needed for repair.

CRT ASSEMBLY 279-9000-70 (OLD)/279-3005 (NEW, EFF. MAY '83)

<u>Part No.</u>	<u>Nomenclature</u>
210-7456*	PCA 12" Monitor Electronics
220-0262	Printer-to-CRT Cable
220-0288	Printer-to-CRT Cable (New, effective May 1983, BNC Connector each end)
270-0633	12" Monitor & Bezel Assembly (Tilting), Green
270-0826	12" Monitor & Bezel Assembly (Tilting), Green, with BNC Connector (Effective May, 1983)
336-0035	Brightness & Contrast Controls
449-0368	CRT Pan
449-0369	CRT Base
449-0370	12" CRT Bezel
449-0371	CRT Cover
449-0437	PC Board Cover
452-2674	Clamp Bezel
650-3129	Screw #6-32 x 3/8 Flange Whiz-Lock
650-3135	Screw #6-3 x 3/8 Pan Hd Phil
650-3207	Screw, Pan Hd, Phil
650-4243-W	Screw, #8-32 x 3/4 Pad Hd Phil
651-0021	Screw, #8-32 x 1/2 Truss Hd, Self-Tap
653-3000	Washer No. 6 Flat
655-0202	Feet, HW LG W/Washer

*RSL Part

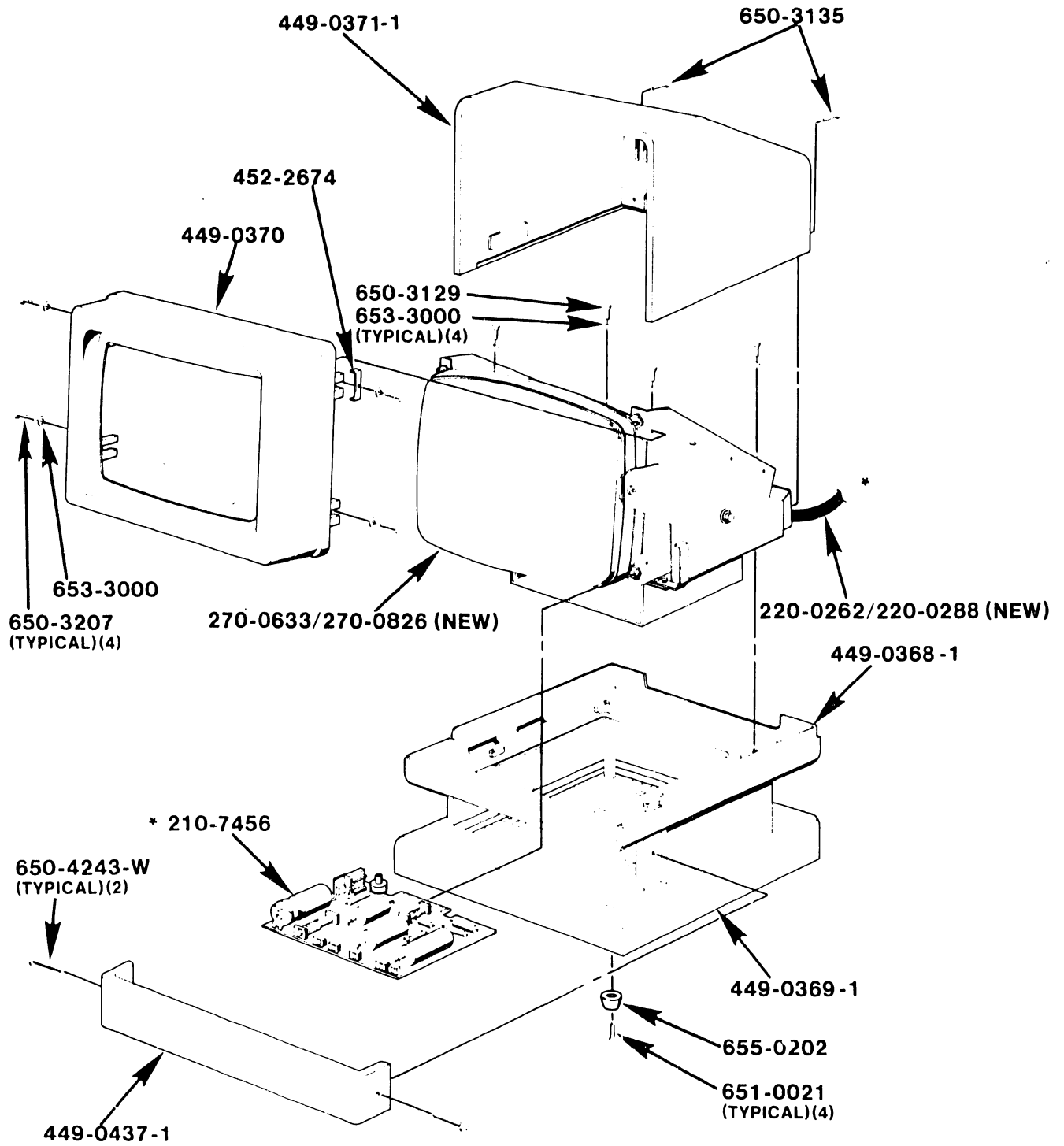

* RSL PART

FIGURE 7-1 CRT ASSEMBLY 279-9000-70/279-3005 (NEW ASSEMBLY)

KEYBOARD ASSEMBLY 279-9000-90 (44 Key)/-92 (48 Key)

220-1505	Keyboard to Printer Cable
279-9000-90	Keyboard Assembly - Standard
279-9000-91	Speaker Assembly, Keyboard
279-9000-92	Keyboard Assembly - International
449-0372	Base, Keyboard
452-0571	Plate, Keyboard Finishing
562-2003	Nut, 7/16, Hex
615-0390	Program Strip (Marking)
650-2140	Screw, Pan Hd 4-40 x 7/16
650-3167	Screw, Whiz Lock, 6-32 x 1/2
650-6642	Flat Hd Screw 10-32 x 5/8
651-0074	Screw, 10-32 x 3/8, Sheet Metal Hex Hd
652-0032	Locknut, Keps, 6-32
653-2000	Flat Washer #4
653-3000	Washer, Flat, #6
653-6002	Washer, Flat, #10
655-0278	Self Adhesive Rubber Feet, White
725-2635*	MWP Keyboard Assembly Kit
725-2653*	MWP Keyboard Assembly, 48 Key Expanded (International only)

*RSL Part

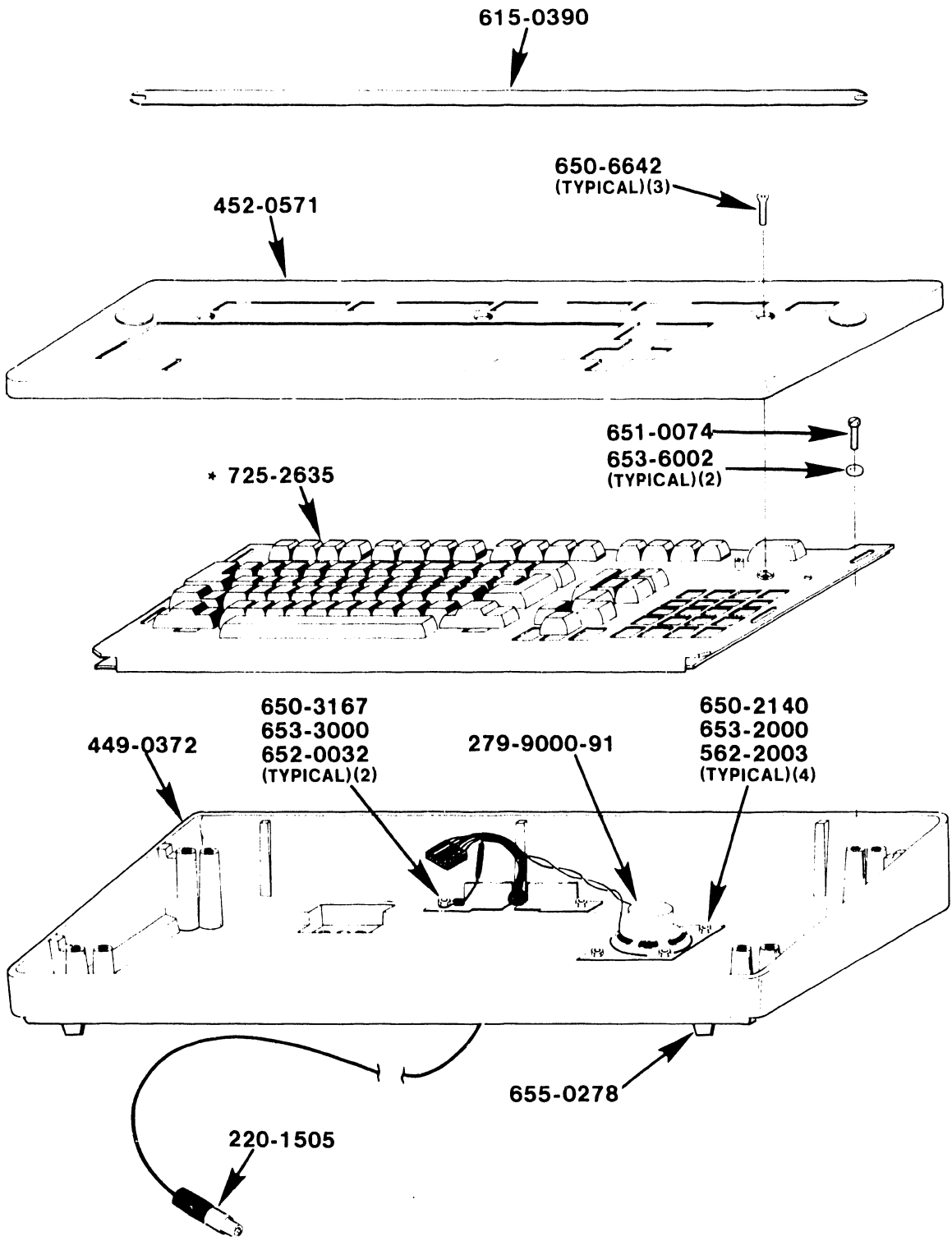

* RSL PART

FIGURE 7-2 KEY BOARD ASSEMBLY 279-9000-90/92

LEFT SIDE ASSEMBLY - 5503

220-3131	Cable, Disk Signal
278-4022*	5" Mini Floppy with Door Lock
370-0026*	Lamp, Red (LED), MV5024
449-0343	Side Panel, One Disk
449-0485	Door, Side Panel, Load Lever
449-0486	Cover, Glider, Rubber
449-0493	Printer Cover Assembly, Plexiglass
449-0515	Side Panel, Two Disk
452-0233	Plate, Support, Dual Disk
650-3061	Screw, Machine, F.H., 6-32 x .25
651-0006	Screw, #6 Self Tap, 1/2 Lg Type B, Slit Pex
655-0010	Caster, Glide, 1/4 x 20
726-2169	Door Pins, Disk Drive, Tandon
726-8068	Alignment Diskette, 5 1/4" DSDD
726-8069*	Belt, Disk Drive, MPI

*RSL Part

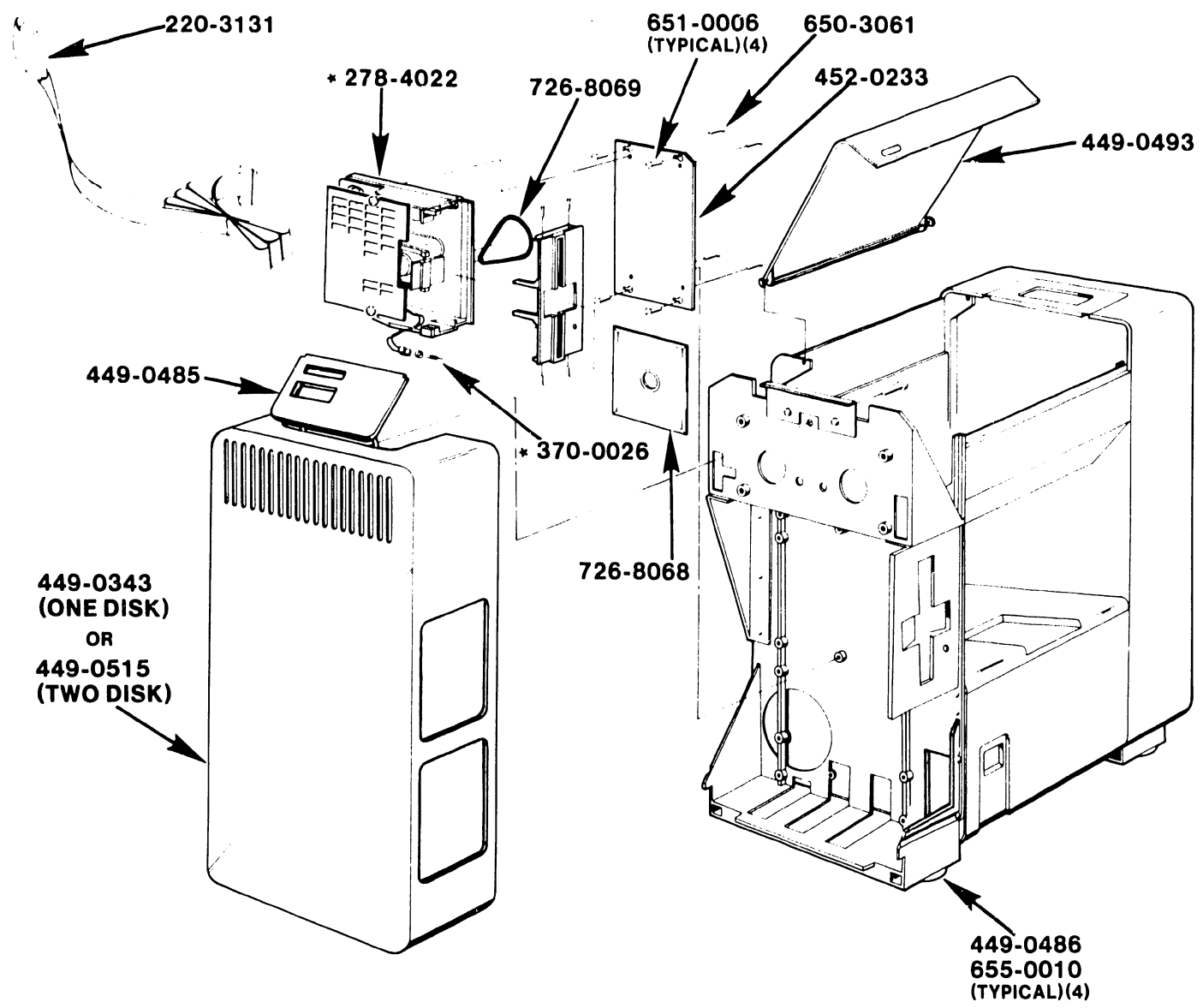

* RSL PART

FIGURE 7-3A LEFT SIDE ASSEMBLY-5503

7-7

LEFT SIDE ASSEMBLY - 5503A/5503D/5504S/5504D

278-4022*	5" Mini Floppy with Door Lock
370-0026*	Lamp, Red (LED), MV5024
220-3131	Cable, Disk Signal (5503)
220-3131M	Cable, Disk Signal 5504 (Shielded)
449-0343	Side Panel, One Disk
449-0485	Door, Side Panel, Load Lever
449-0486	Cover, Glider, Rubber
449-0493	Printer Cover Assembly, Plexiglass
449-0515	Side Panel, Two Disk
452-0231	Facia Plate, Dual Disk
452-0233	Plate, Support, Dual Disk
650-3061	Screw, Machine, F.H., 6-32 x .25
651-0006	Screw, #6 Self Tap, 1/2 Lg Type B, Slt Pex
655-0010	Caster, Glide, 1/4 x 20
726-2169	Door Pins, Disk Drive, Tandon
726-8068	Alignment Diskette, 5 1/4" DSDD
726-8069*	Belt, Disk Drive, MPI

*RSL Part

7-9

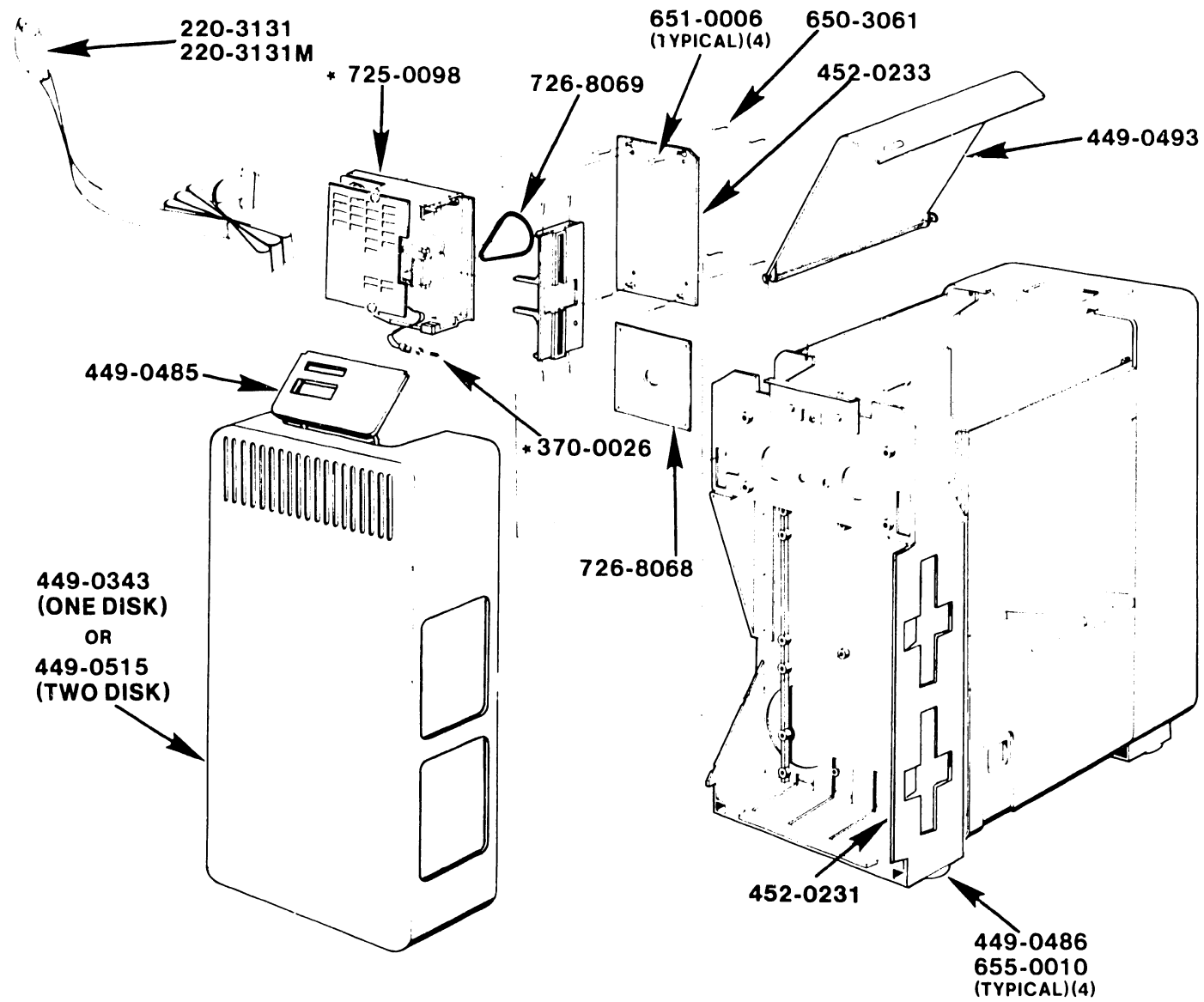

* RSL PART

FIGURE 7-3B LEFT SIDE ASSEMBLY 5503A/5503D/5504S/5504D

RIGHT SIDE ASSEMBLY 5503/5503A/5503D

210-7775*	PCA, MWPS, CRT/Memory Board
210-7776*	PCA, MWPS, Printer Driver Board
210-7777*	PCA, MWPS, CPU/Disk/Keyboard
279-9000-33	Control Panel Assembly
360-1153*	Fuse, Pico, 2.5A
360-1155*	Fuse, Pico, 2.0A
360-1156*	Fuse, Pico, 4.0A
279-9000-35*	MWP Cover Open Switch Assembly
377-0341-L*	2114 RAM, 1024 x 4 bit Static RAM
377-0345-T*	4116 RAM, 16K x 1 bit Dynamic RAM
449-0343	Panel, Side
449-0352	Door, Side Panel (Switch)
449-0436	Spacer, PC Board
462-0495	Spacer
478-1058	Retainer, Side Panel
650-4080	Screw, Pan Hd, P[hillips 8-32 x .25 sems
650-2099	Screw, Pan Hd, 4-40 x .25
652-4006	8-32 Self-Locking Wing Nut

*RSL Parts

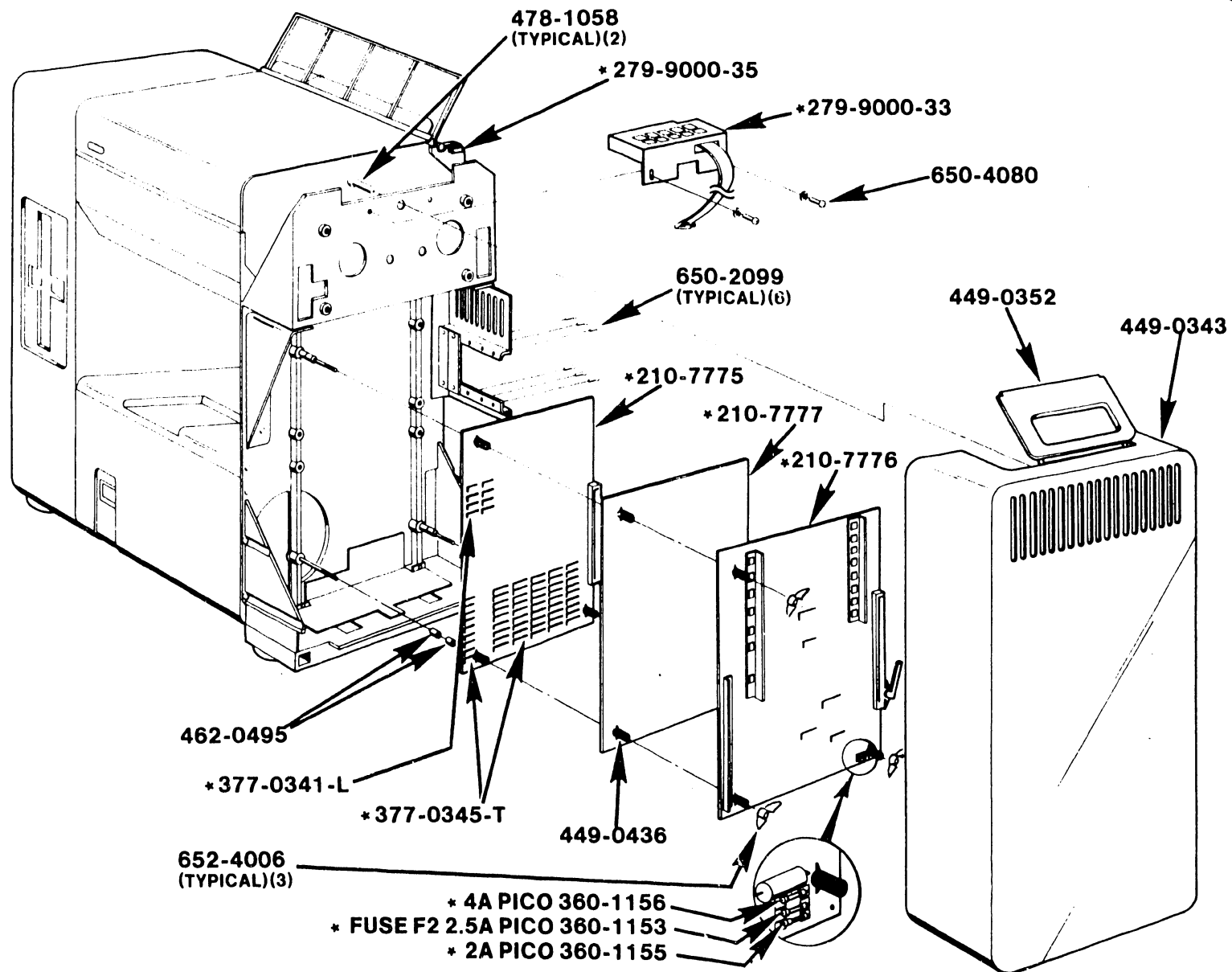

FIGURE 7-4A RIGHT SIDE ASSEMBLY 5503/5503A/5503D

RIGHT SIDE ASSEMBLY 5504S/5504D

210-7975*	PCA, MWPS, CRT/Memory Board
210-7976*	PCA, MWPS, Printer Driver Board
210-7977*	PCA, MWPS, CPU/Disk/Keyboard
212-2200*	PCA, Foreground TC Bd, RS-232 (Optional)
212-2201*	PCA, Foreground TC Bd, X.21 (Optional)
212-2202*	PCA, Foreground TC Bd, RS449 (Optional)
279-9000-33	Control Panel Assembly
279-9000-35	MWP Cover Open Switch Assembly
360-1153*	Fuse
360-1155*	Fuse
360-1156*	Fuse
377-0430	RAM IC 2K x 8
377-0415-HT	RAM IC, 64K x 1, Dynamic
449-0343	Panel, Side
449-0352	Door, Side Panel (Switch)
449-0436	Spacer, PC Board
451-5091	PC Board Blank Bracket
462-0495	Spacer
478-1058	Retainer, Side Panel
650-4080	Screw, Pan Hd, P[hillips 8-32 x .25 sems
650-2099	Screw, Pan Hd, 4-40 x .25
652-4006	8-32 Self-Locking Wing Nut

*RSL Part

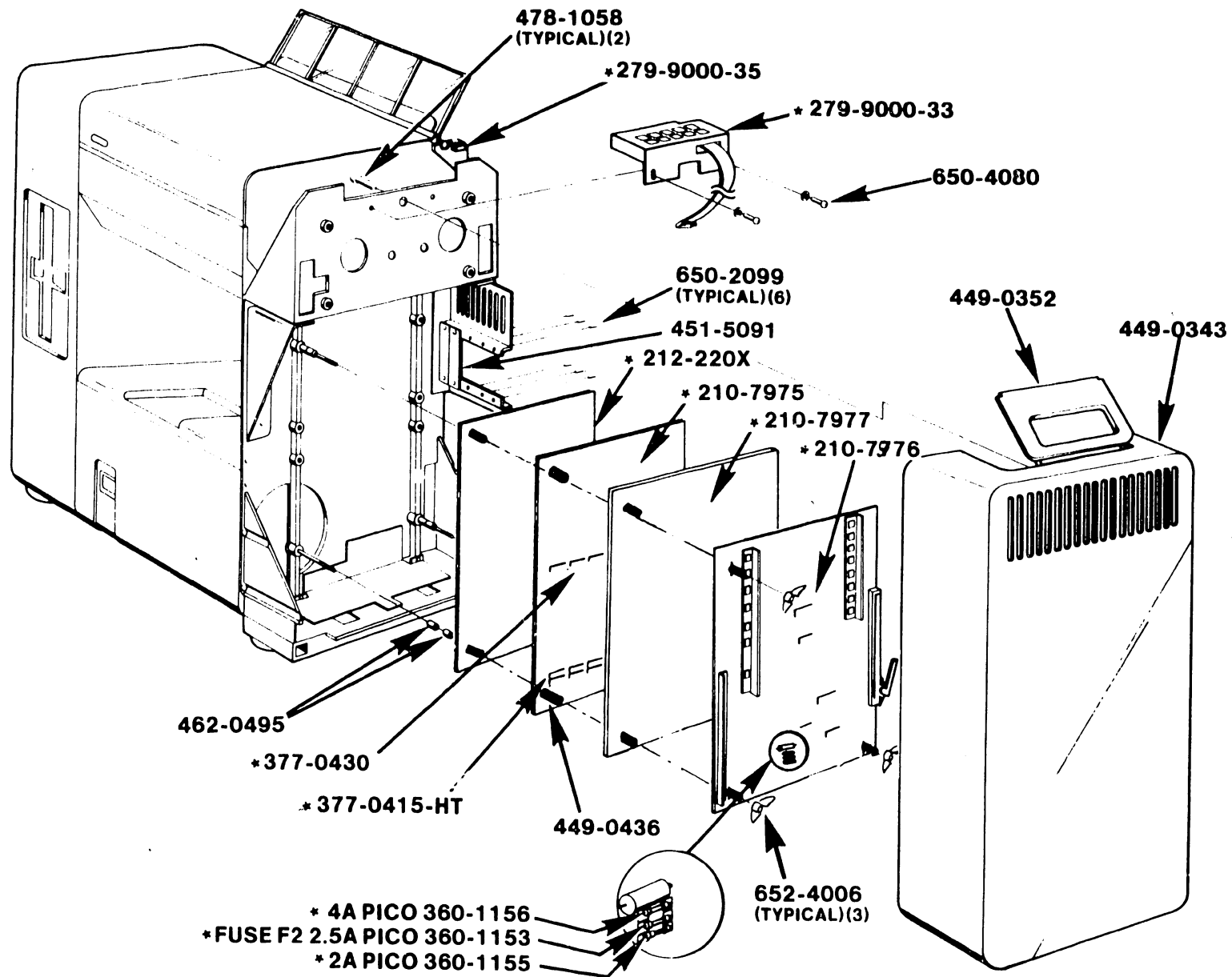

FIGURE 7-4B RIGHT SIDE ASSEMBLY 5504S/5504D

PRINTER MECHANISM ASSEMBLY 279-9000-10 (5503)

5104

220-3139*	Head Cable Assembly, Flex	449-0682	Clip, Bail Roller
279-0531	MWP Bail Roller Assembly	451-1272	Paper Tray
279-9000-20	Assembly Platen (complete)	452-4141	Card Guide
279-9000-21	Assembly, Paper Guide (complete)	458-0866	Retainer, Shaft
279-9000-22	Print Head Assembly	458-1262	Shim, Anti-Rotate, Paper Out Sensor
279-9000-26*	Motor, Carriage Drive	461-3498	Rod, Paper Bail
279-9000-27*	Motor, Paper Drive	461-3518	Carriage, Guide Shafts
279-9000-30	Frame Assembly, Side, L.H.	465-1720	Spring, Platen Paper Guide
279-9000-31	Frame Assembly, Side, R.H.	465-1741	Spring, Extension Latch
279-9000-26*	Motor, Carriage Drive	478-0744*	Pulley Bearing, Mt
279-9000-27*	Motor, Paper Drive	478-1055	Spring, Tension Release
279-9000-35	Switch Assembly, Cover Open	478-1056	Spring, Bail Return
279-9000-36	Paper Motor Idler Gear Assembly	650-0045	Screw, Paper Out Sensor
279-9000-42	Spike Driver Assembly	650-2120	Screw, 4-40 x 3/8 Pan Hd Phl MS SS SEMS
325-2309M2	Microswitch, Ribbon Type	650-4133	Screw, 8-32 x 3/8 Flange Whiz-Lock MS Zinc
375-2110-4*	Sensor, Ribbon Out	651-1722	Ring, Retainer .123 Sft Dia Ext Grip-On
375-2120*	Sensor, R & L Margin & Paper Out	651-1745	Ring, Retainer .185 Sft Dia Ext Grip-On
420-1033	Cable, Carriage Drive	653-4000	Washer, #8 .174 ID .375 OD .016 PLSS
449-0421*	Cam, Paper Release	655-0276	Bumper, Carriage, R.S.
449-0422	Idler Lever, Bail	656-0108	Ring, Bail Roller
449-0426*	Arm, Paper Release		
449-0427*	Paper Bail Arm, R		
449-0428*	Paper Bail Arm, L		
449-0457	Paper Tray Assembly		
449-0485*	Cam, Load Lever		
449-0487*	Paper Load Lever		
449-0492*	Cap, Button		

*RSL Part

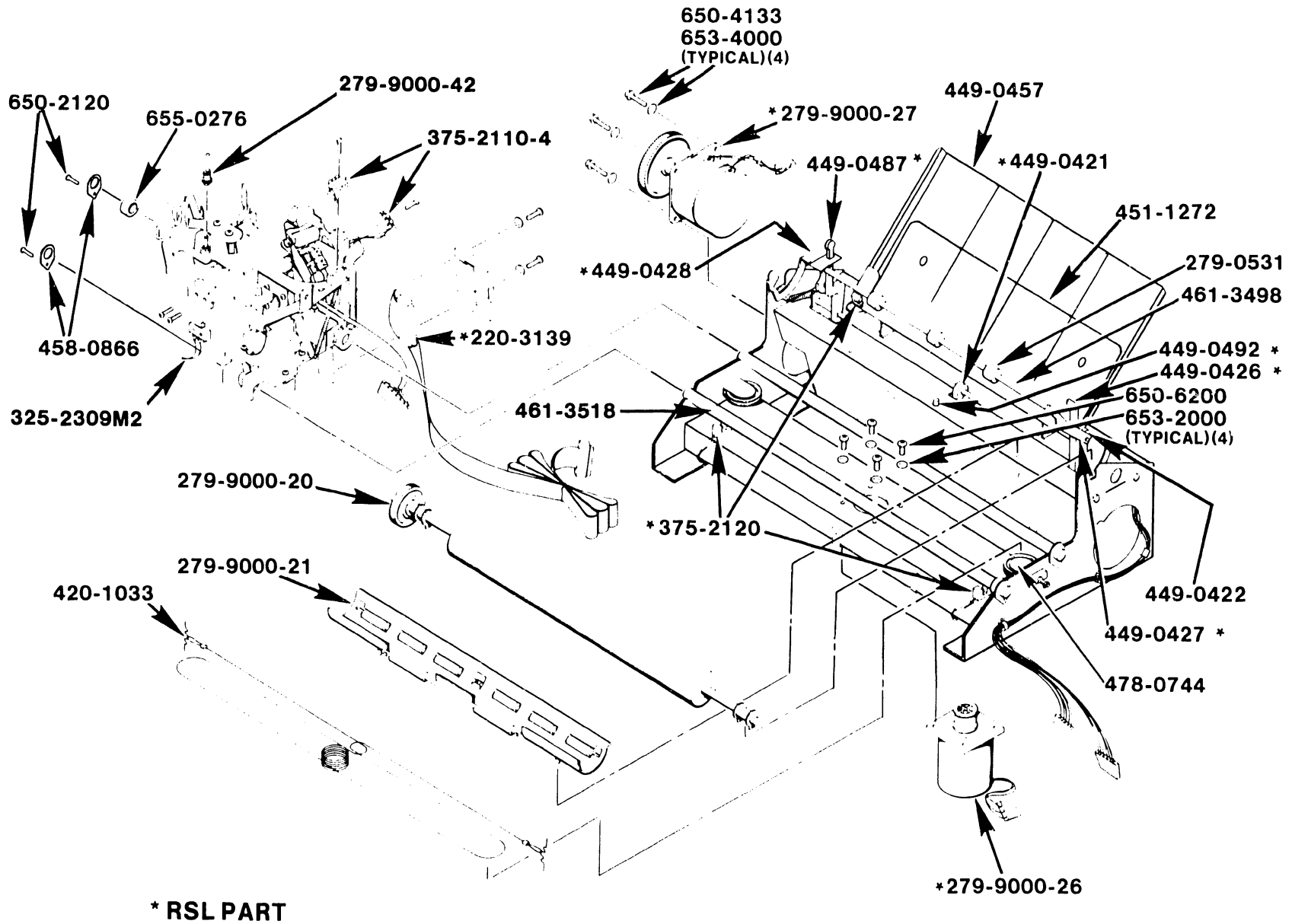

FIGURE 7-5A PRINTER MECHANISM ASSEMBLY 279-9000-10 (5503)

PRINTER MECHANISM ASSEMBLY 279-9002-10 (5504/5524)

5104

220-3139M*	Head Cable Assembly, Flex	449-0682	Clip, Bail Roller
279-0531	MWP Bail Roller Assembly	451-1272	Paper Tray
279-9000-20	Assembly Platen (complete)	452-4141	Card Guide
279-9000-21	Assembly, Paper Guide (complete)	458-0866	Retainer, Shaft
279-9000-22	Print Head Assembly	458-1262	Shim, Anti-Rotate, Paper Out Sensor
279-9000-26*	Motor, Carriage Drive	461-3498	Rod, Paper Bail
279-9000-27*	Motor, Paper Drive	461-3518	Carriage, Guide Shafts
279-9000-30	Frame Assembly, Side, L.H.	465-1720	Spring, Platen Paper Guide
279-9000-31	Frame Assembly, Side, R.H.	465-1741	Spring, Extension Latch
279-9002-26*	Motor, Carriage Drive	478-0744*	Pulley Bearing, Mt
279-9002-27*	Motor, Paper Drive	478-1055	Spring, Tension Release
279-9000-35	Switch Assembly, Cover Open	478-1056	Spring, Bail Return
279-9000-36	Paper Motor Idler Gear Assembly	650-0045	Screw, Paper Out Sensor
279-9000-42	Spike Driver Assembly	650-2120	Screw, 4-40 x 3/8 Pan Hd Ph1 MS SS SEMS
325-2309M2	Microswitch, Ribbon Type	650-4133	Screw, 8-32 x 3/8 Flange Whiz-Lock MS Zinc
375-2110-4*	Sensor, Ribbon Out	651-1722	Ring, Retainer .123 Sft Dia Ext Grip-On
375-2120*	Sensor, R & L Margin & Paper Out	651-1745	Ring, Retainer .185 Sft Dia Ext Grip-On
420-1033	Cable, Carriage Drive	653-4000	Washer, #8 .174 ID .375 OD .016 PLSS
449-0421*	Cam, Paper Release	655-0276	Bumper, Carriage, R.S.
449-0422	Idler Lever, Bail	656-0108	Ring, Bail Roller
449-0426*	Arm, Paper Release		
449-0427*	Paper Bail Arm, R		
449-0428*	Paper Bail Arm, L		
449-0457	Paper Tray Assembly		
449-485*	Cam, Load Lever		
449-0487*	Paper Load Lever		
449-0492*	Cap, Button		

*RSL Part

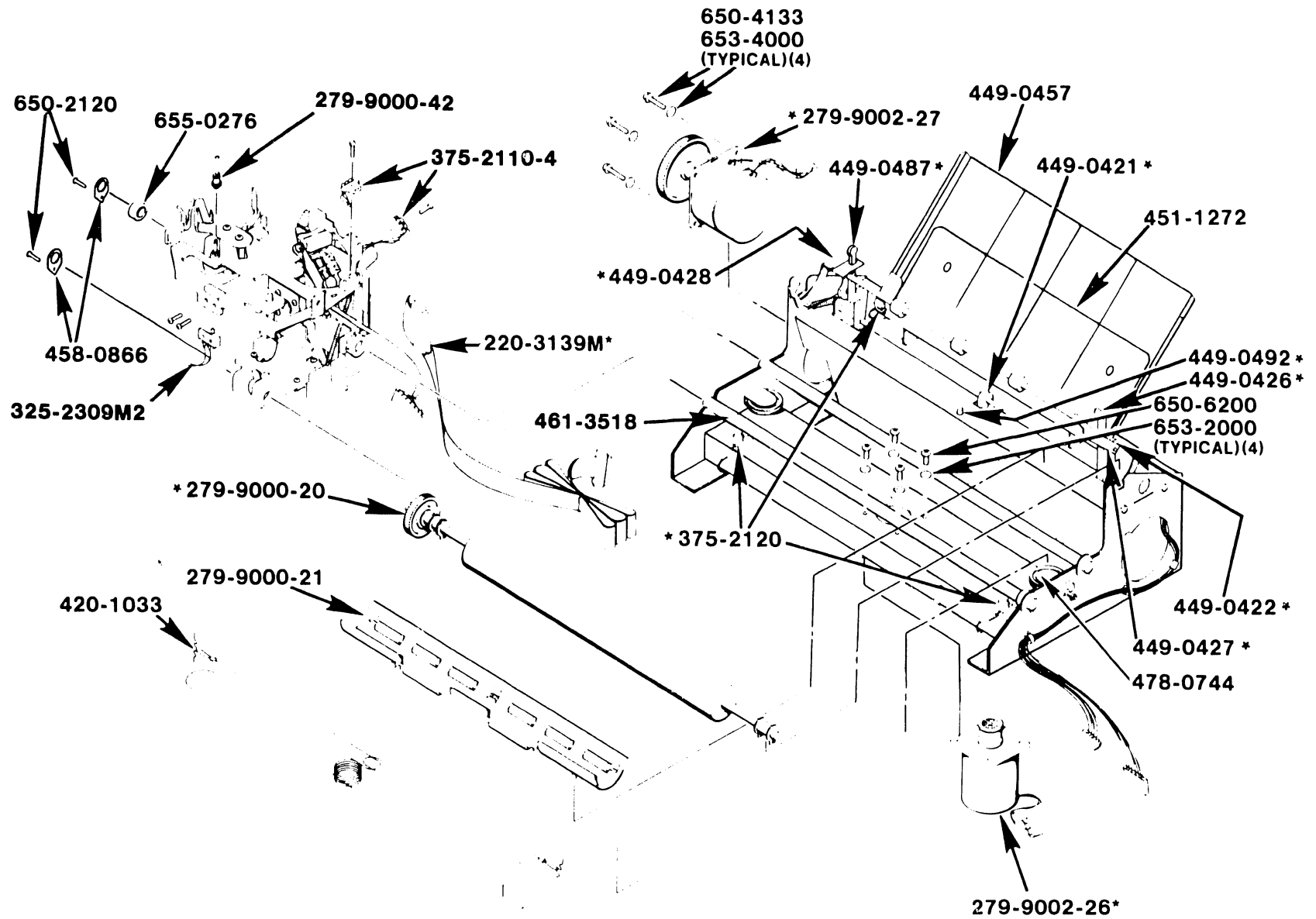

7-17

FIGURE 7-5B PRINTER MECHANISM ASSEMBLY 279-9002-10 (5504)

HEAD ASSEMBLY 279-9000-22

220-3139M*	Head Cable Assembly, Flex (Shielded - 5504/5524)
220-3139*	Head Cable Assembly, Flex (5503)
279-9000-41	Ribbon Motor & Gearbox Assembly
279-9000-42*	Spike Driver Assembly
325-2309-M2	Microswitch, Ribbon Type
375-2110-4*	Sensor, Daisy Home & Ribbon Exhaust
449-0410	Retainer, Cable Connector
449-0416	Catch, Ribbon Driver
449-0417*	Clip, Motor Latch
452-4141	Card Guide, Wide (Required for use with Single Sheet Feeder only)
458-0862	Lever, Ribbon Drive Assembly
458-0926	Flag, Margin Switch
461-3516	Shaft, Spike Driver
461-0063	Retainer, Screw, Ribbon Microswitch
465-1236	Card Guide
465-1757	Spring, Hammer, Compression
478-0708-M	Hammer, Printer
650-0008	Screw, 1-64 x 3/8 Lg Pan Hd, Slot Cad Plt
650-0124	Screw
650-0160	Screw, .2-56 x 1/2 Pan Hd MSSS
650-2100	Screw, 4-40 x 5/16 Phl Ph MS SS
650-2071	Screw, 4-40 x 1/8 Btn Hd Soc Blk Ox
650-2087	Screw, 4-40 x 1/4 Pan Hd Phl MS SS Mag Sems
650-2240	Screw, 4-40 x 3/4 Pan Hd Phl MS SS SEMS
651-1762	Retainer Ring, .094 Set Dia Ext Type E
653-0990	#2 Int T Lock Washer
653-0991	#2 Flat Washer
653-2000	#4 Flat Washer
653-2001	#4 Flat Washer
653-2002	Washer, 4.123 ID, .265 OD INT T ST

*RSL Part

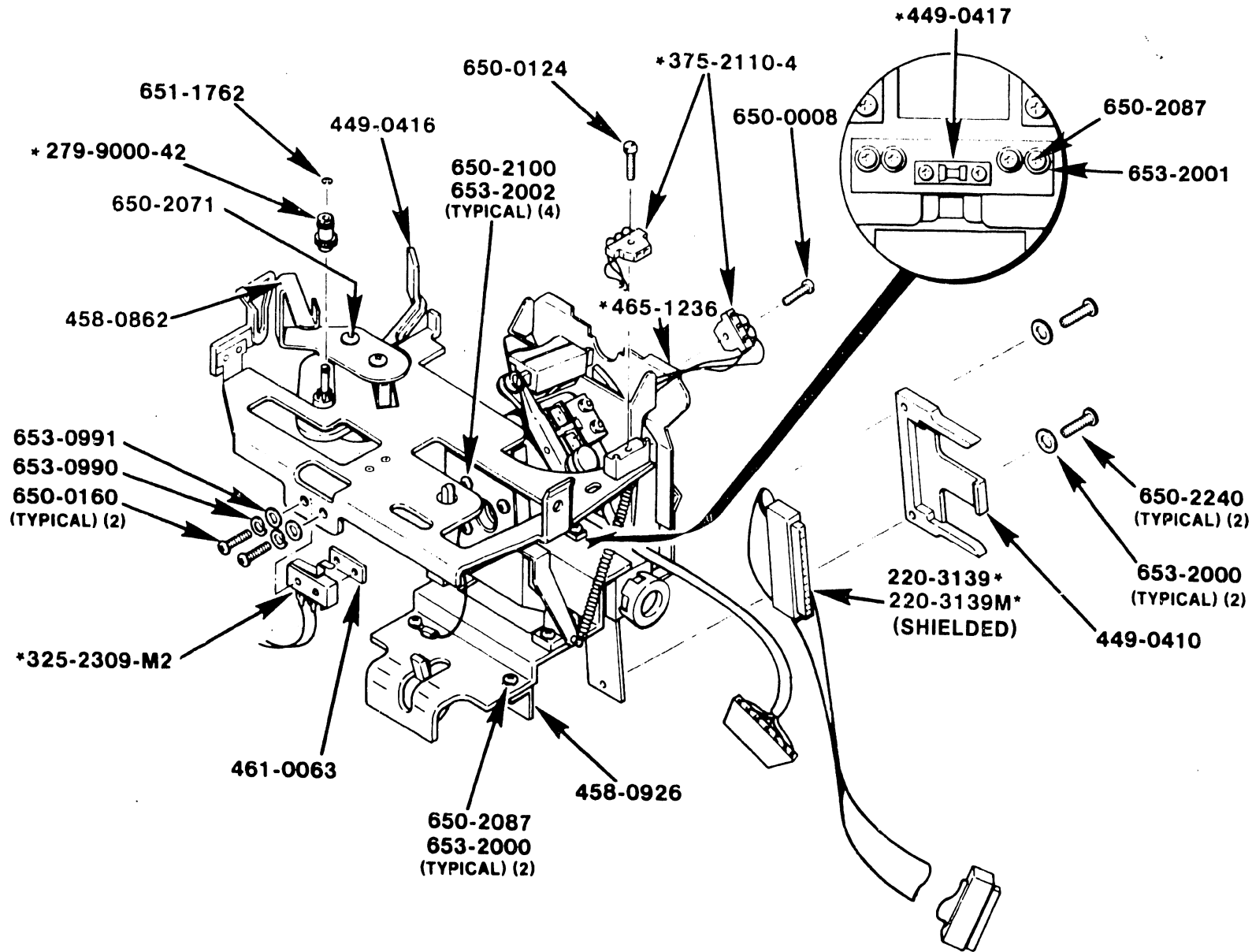

FIGURE 7-6 HEAD ASSEMBLY 279-9000-22

MOTOR MOUNT ASSEMBLY

1	279-9000-25	Daisy Motor Assembly
2	279-9000-29	Print Yoke Assembly
3	279-9000-39	Motor Pivot Assembly
4	279-9000-40	Daisy Damper Assembly
5	465-1660	External Spring, Arm Return
6	465-1757*	Spring, Comp Hammer
7	478-0578	Mount, Solenoid
8	478-0708-M*	Hammer, Print
9	650-2070	4-40 x 3/16 Truss Hd Socket Screw
10	650-2100	Screw, 4-40 x 5/16, Phil Pan Hd MS SS
11	650-2120	4-40 x 3/8 Pan Hd Phil MS SS SEMS (no substitution)
12	650-2200	4-40 x 5/8 Pan Hd Phil MS SS SEMS
13	650-3100	Screw, 6-32 x 5/16 Phl Ph MS SS
14	653-2000	No. 4 Flat Washer
15	653-2002	Washer, #4, Lock, Int Tooth
16	653-3000	Washer, #6, .149 ID, .375 OD, .016 FL SS
17	653-3001	Washer, #6, .150 ID, .288 OD, Int T ST

7-21

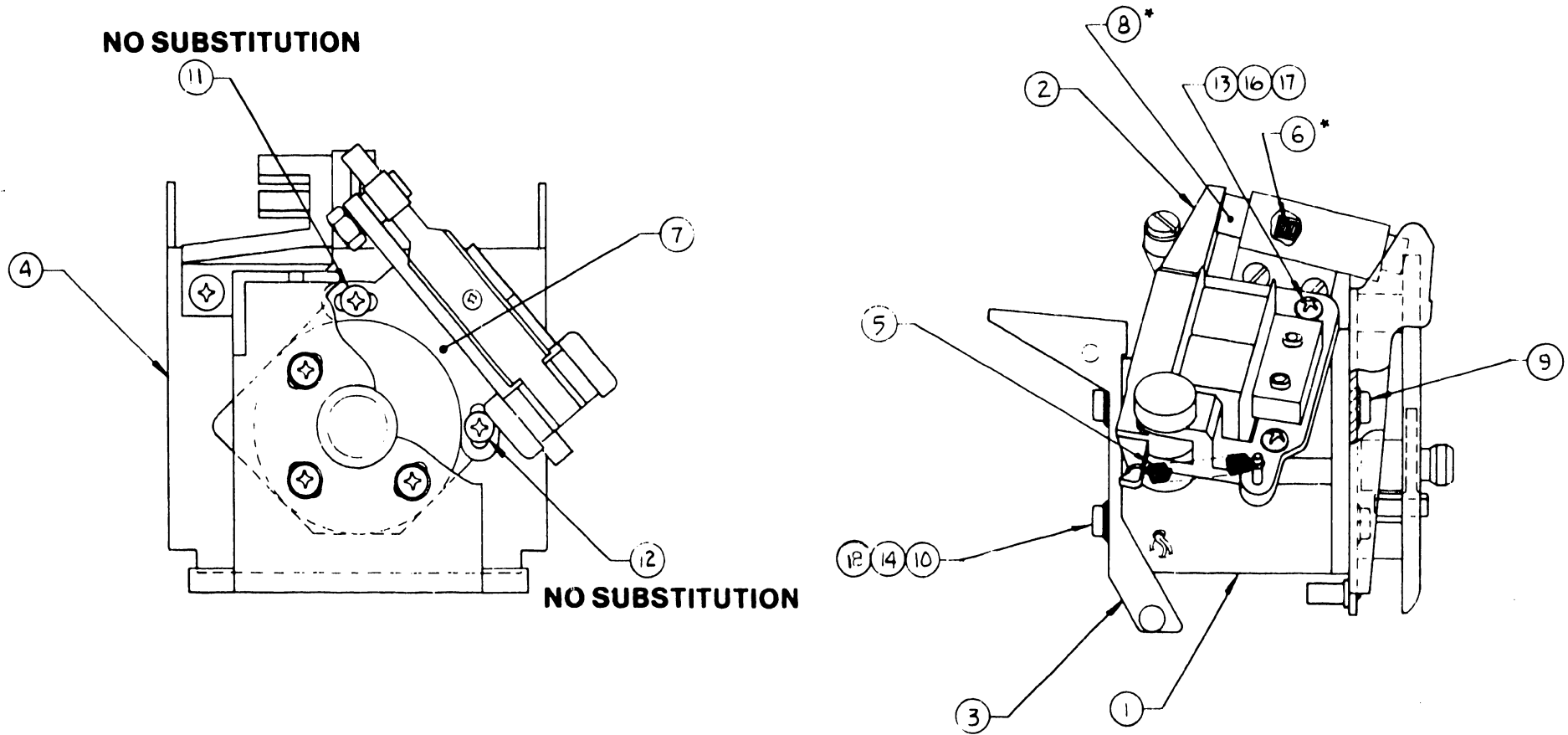

FIGURE 7-7 MOTOR MOUNT ASSEMBLY

DAISY DAMPER ASSEMBLY

1	279-9000-16	Bracket Assembly, Damper
2	449-0415	Housing, Print, Hmr Mld
3	449-0418	Damper, Daisy Wheel
4	449-0453	Mount, Daisy Home Switch
5	449-0454	Bracket, Hammer Housing
6	650-1160	SCR 3-48 x 1/2 Slot PH MS SS
7	650-2284	4-40 x 7/16 Flat Hd Ph1 MS SS SEMS (no substitution)
8	650-3120	6-32 x 3/8 Pan Hd Ph1 MS SS SEMS
9	652-0990	Nut 2-56 Unc Hex Small PAI SS
10	653-9009	Washer 2 Int T ST
11	653-0991	No. 2 Flat Washer
12	653-3000	No. 6 Flat Washer
13	660-0160	Loctite, Grade A Sealant
14	653-0047	No. 3 Flat Washer
15	452-0224	Plate, Nut, Damper
16	653-1000	No. 3 Int Tooth Lock Washer, ST
17	452-0224	Nut Plate
18A	653-0126	Shim, Damper, .010 thk, 1/8 x 1/4
18B	653-0107	Shim, Damper, .005 thk, 1/8 x 1/4

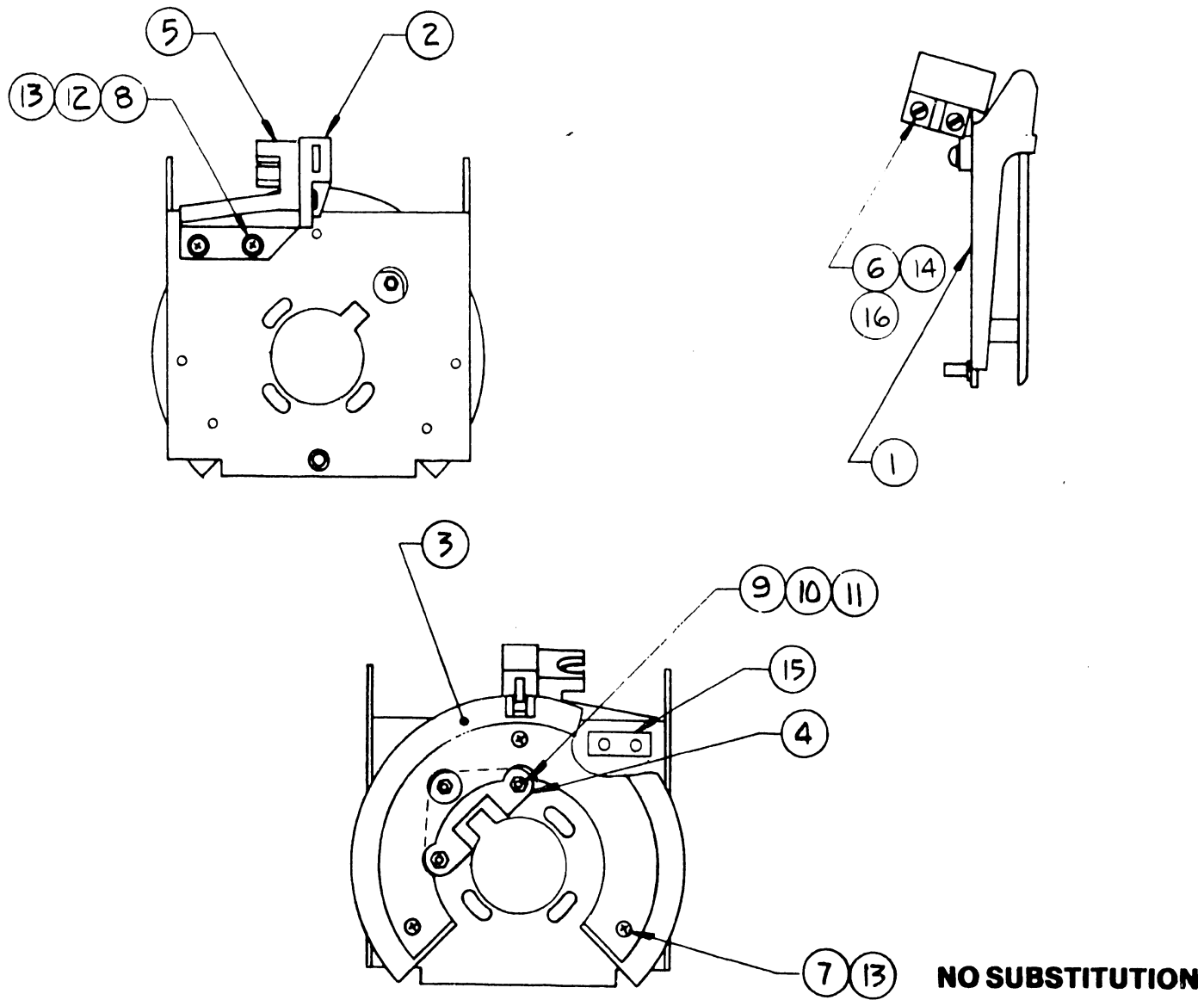

FIGURE 7-8 DAISY DAMPER ASSEMBLY

POWER SUPPLY ASSEMBLY 279-9000-32 (5503)

220-1849	Power Cable, Disk
279-9000-34*	Regulator, Power Supply W/Heat Sink
325-0059	Switch, DPS Rocker
323-0010	Counter, Printer
325-0059	Switch, DPS Rocker
325-2118	Switch, Slide, DPDT, 115/230V
360-0017	Fuse Holder
360-0018	Fuse Carrier
360-1020*	Fuse, SB, 2 Amp, 220V
360-1040*	Fuse, SB, 4 Amp, 110V
360-1155*	Fuse, Pico 2A
400-1012	Fan, Muffin 50
420-2010	Power, kCable, AC
650-2120	Screw, 4-40 x 3/8 Pan Hd Phl MS SS SEMS
650-3080	Screw, 6-32 x 1/4 Pan Hd Phl MS SS SEMS
650-3167	Screw, 6-32 x 1/2, Flange Whiz-Lock MS Zinc
650-3640	Screw, 6-32 x 2 Phil Hd MS SS
652-0032	6-32 Lock Nut KEPS
652-2005	4-40 Lock Nut KEPS
653-2000	#4 Flat Washer
653-3000	Washer, 6.149 ID .375 OD .016 FLSS
653-3001	Washer, 6.150 ID .288 OD Int T ST
653-3003	Washer, 6.141 ID .253 OD Split SS

*RSL Part

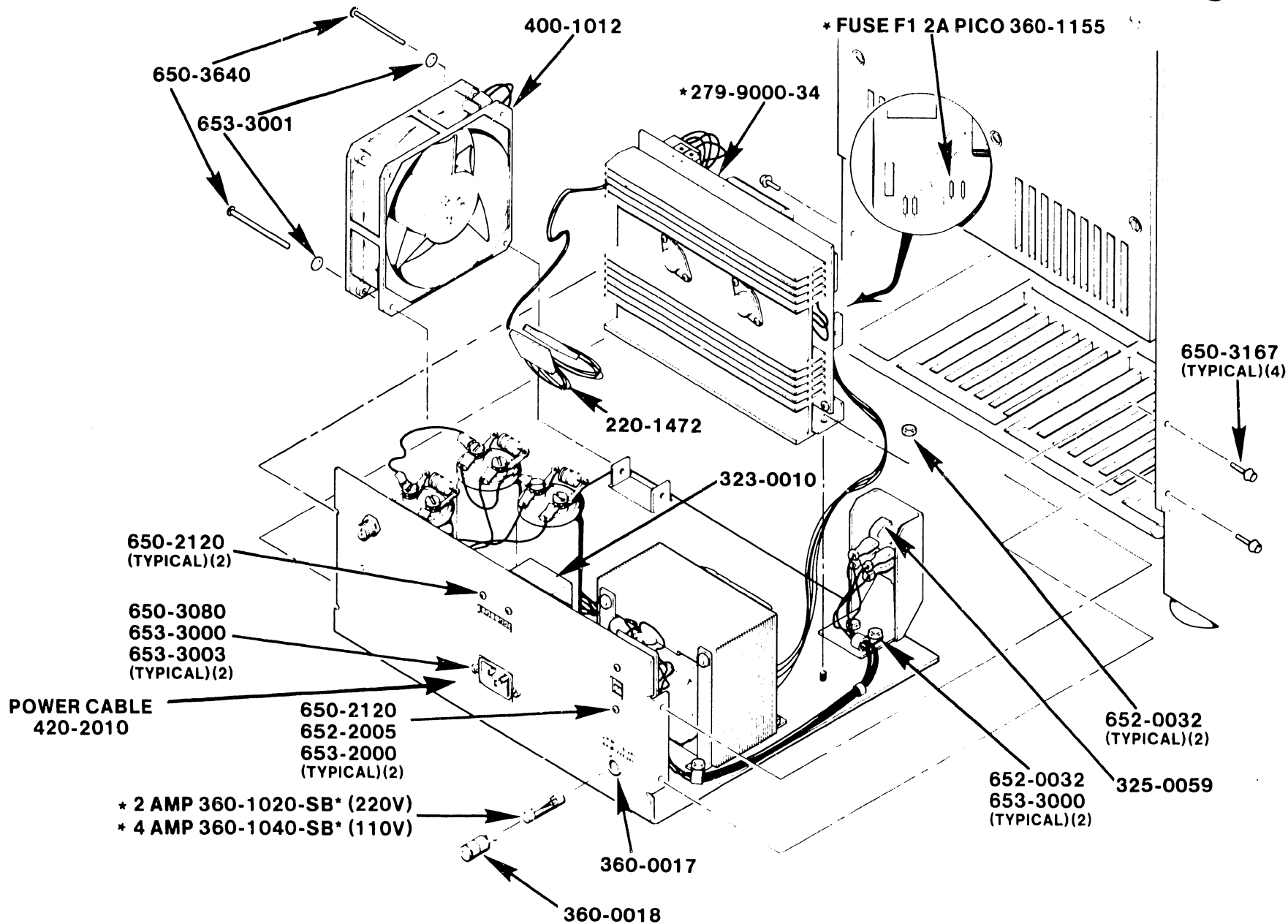
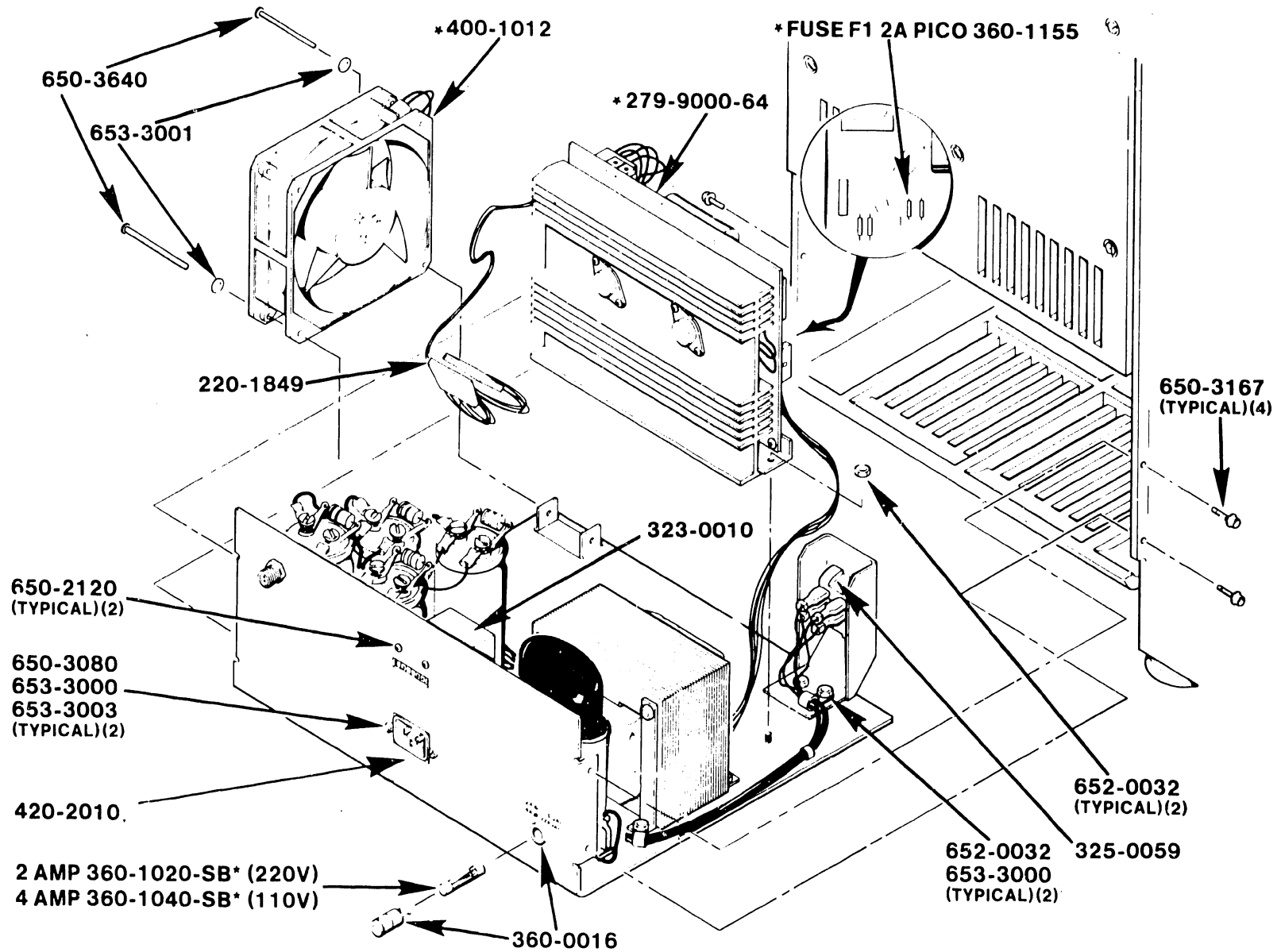

FIGURE 7-9A POWER SUPPLY ASSEMBLY 279-9000-32

POWER SUPPLY ASSEMBLY 270-0838/-1 (5504/5524)

220-1849	Power Cable, Disk
270-0838	Power Supply, 60 Hz, Linear with Heat Sink and Regulator
270-0838-1	Power Supply, 50 Hz, Linear with Heat Sink and Regulator
279-9000-62	Power Supply (60 Hz) without Regulator
279-9000-63	Power Supply (50 Hz) without Regulator
279-9000-64*	Regulator, P.S. W/Heat Sink
323-0010	Counter, Printer
325-0059	Switch, DPS Rocker
360-0017	Fuse Holder
360-0018	Fuse Carrier
360-1020*	Fuse, SB, 2 Amp, 220V
360-1040*	Fuse, SB, 4 Amp, 110V
360-1155	Fuse, Pico, 2 Amp
400-1012	Fan, Muffin 50
420-2019	Power Cable, AC
650-2120	Screw, 4-40 x 3/8 Pan Hd Phl MS SS SEMS
650-3080	Screw, 6-32 x 1/4 Pan Hd Phl MS SS SEMS
650-3167	Screw, 6-32 x 1/2, Flange Whiz-Lock MS Zinc
650-3640	Screw, 6-32 x 2 Phil Hd MS SS
652-0032	6-32 Lock Nut KEPS
653-3000	Washer, 6.149 ID .375 OD .016 FLSS
653-3001	Washer, 6.150 ID .288 OD Int T ST
653-3003	Washer, 6.141 ID .253 OD Split SS

*RSL Part



7-27

FIGURE 7-9B POWER SUPPLY ASSEMBLY 270-0838 (60Hz)/-1(50Hz)

CHAPTER

8

**TROUBLE-
SHOOTING**

CHAPTER 8
TROUBLESHOOTING

This chapter contains instructions/procedures, for the analyzing and correcting of system problems, in the following categories:

- | | |
|-------------------------------|--|
| System Diagnostics: | - Describing use of the System Diagnostic diskette to exercise various aspects of system operation. |
| Power Distribution | - Showing power generation from the ac input through the derivation and distribution of the dc voltages. |
| Trouble Analysis Flow-charts: | - Giving step-by-step procedures for the isolating of system malfunctions to given areas or components. |

8.1 SYSTEM DIAGNOSTICS

System Diagnostics consist of ten programs, selected either singly or in combination:

<u>NAME (REVISION)</u>	<u>HARDWARE TESTED</u>
Printer (1271)	Printer mechanism
Main Memory (1278)	Main memory starting at 4000 (hex)
CRT Memory (1110)	CRT memory (except soft character generator)

Continued next page -

Diagnostic programs (continued):

<u>NAME (REVISION)</u>	<u>HARDWARE TESTED</u>
Z80 Instruction Set (1110)	CPU chip (internal hardware)
CTC (1110)	CTC (on the CPU/disk board)
Disk (1194)	Disk controller and disk drive
Display & Keyboard (613A)	CRT attributes, soft character memory, keyboard logic and keys and screen display
Lamp & Status (6198)	Printer switches, lamps, sensors, character counter; 7-segment display; device type (IN07) switch bank
VCO adjustment (8190)	Voltage-Controlled Oscillator
FTC Test (1290)	Tx/Rx and DMA functions of FTC board.

To begin the System Diagnostics:

1. Turn on the system power, then insert the System Diagnostics diskette WLI 723-8001 (5503) or WLI 723-8001 (5504). Within 30 seconds, press CANCEL to begin diagnostic testing. The main system diagnostic menu should appear on the monitor (if no key is struck within 30 seconds of disk insertion, the program defaults to the automatic burn-in routine).
2. When the menu appears, position the cursor by pressing:
 - up arrow or BACK SPACE (= up)
 - down arrow or space bar (= down)
3. Select, or deselect, programs using:
 - INSERT = select
 - DELETE = de-select
4. Key EXECUTE to begin the selected test(s). The following run-time menu appears on the monitor (except when the Display and Keyboard test is selected; see paragraph 8.1.6):

INDENT = Error Loop PAGE = Routine Loop CENTER = Stop on Error
 DECTAB = Program Loop FORMAT = Pause MERGE = Scope Loop
 STOP = Clear All Settings

Program Name:	Program Status	:
Routine Name:	Program Status Count:	
Error Code :	Routine Loop Count	:
Error Count :	Program Loop Count	:
	Keyboard Status	:

Messages:

At the beginning of the run-time menu is a quick reference summary of the command functions assigned to particular control keys during the System Diagnostic program. These command functions are, as follows (key names are in parentheses):

- Error loop (INDENT) - Loop on routine in which the next failure occurs.
- Loop on Program (DECTAB) - Loop on current diagnostic program.
- Pause (FORMAT) - Halt the program.
- Test Loop (PAGE) - Loop on current test routine.
- Clear all Settings (STOP) - If looping, stop; if halted, resume testing.
- Scope Loop (MERGE) - Loop on next test routine in which a hardware failure occurs.
- Stop on Error (CENTER) - Stop the diagnostic program where the next failure is detected.
- Error Log (COMMAND) - Display the error log screen.
 Use NEXT SCRN to return to the
 run-time menu and clear the error log.
 Use PREV SCRN to return to the
 run-time menu and save the error log.

Immediately below the command summary, the run-time menu displays test results as the test is in progress.

Program Name - current test name

Routine Name - current routine within test

Error Code - the number of the most recently detected error

Error Count - Cumulative error count - cleared by a return to the program selection menu

Program Status - current operation in progress, e.g., test in progress, program paused, etc.

Program Set Count - count of loops made through the set of programs - cleared by a return to the program selection menu

Routine Loop Count - count of the loops made through the current routine

Program Loop Count - count of the loops made through the current program

Keyboard Status (locked/unlocked) - indicates whether keystrokes are to be accepted (unlocked) when made, or delayed. If a key is struck while the keyboard is locked, the struck key highlights until accepted. During this (locked) period, the unit ignores subsequent keystrokes.

In the lower half of the run-time menu, the current test program writes error messages and user prompts. If more than one error occurs, only the last error message is left on display, although the error count continues.

When EXECUTE is keyed the selected diagnostic programs run in the order shown on the program-selection menu. If testing is altered by means other than operator action or by hardware failure, the monitor automatically repeats the set of selected diagnostic programs. Keying CANCEL causes the monitor to redisplay the program-selection menu.

NOTE

EACH DIAGNOSTIC PROGRAM RUNS UNTIL EITHER
COMPLETED OR AN ERROR IS DETECTED.

8.1.1 MAIN MEMORY DIAGNOSTIC

The Main Memory diagnostic consists of:

<u>TEST NO.</u>	<u>TEST NAME</u>
01	Data Bus Test
02	Memory Select Test
03	Address-line shorts, stucks, and opens test (Chip Address Test)
04	Two-pattern moving inversions memory data test (Memory Data Test)
05	Memory Refresh Test

All error messages begin in this form:

(type of error) at (address) and page xx (5503) or bank (5504)
 Received data = xx
 Expected data = yy

The address, in conjunction with the paging, indicates the row containing the faulty chip as follows:

Model 5503

Bank #	Page #	Address
0	N/A	0000-3FFF
1	N/A	4000-7FFF
2	0	8000-BFFF
2	1	8000-BFFF
2	2	8000-BFFF
2	3	8000-BFFF

Figure 8-1 identifies pages via the following notation:

$\overline{\text{PG2}} \cdot \overline{\text{PG1}} = \text{Page 0}$

$\overline{\text{PG2}} \cdot \text{PG1} = \text{Page 1}$

$\text{PG2} \cdot \overline{\text{PG1}} = \text{Page 2}$

$\text{PG2} \cdot \text{PG1} = \text{Page 3}$

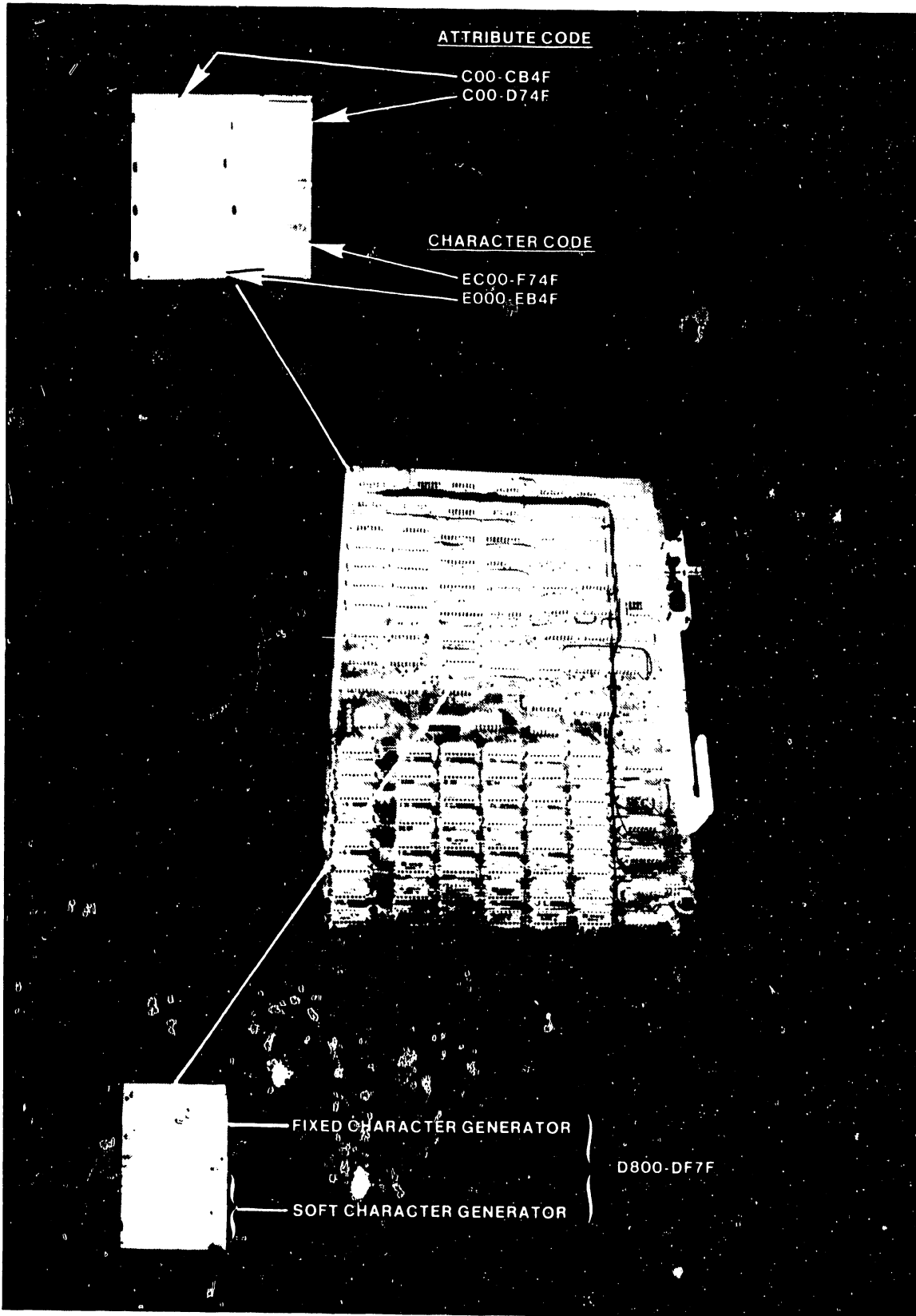

FIGURE 8-1 BOARD LOCATION OF MEMORY ADDRESSES-MODEL 5503 (1 OF 2)

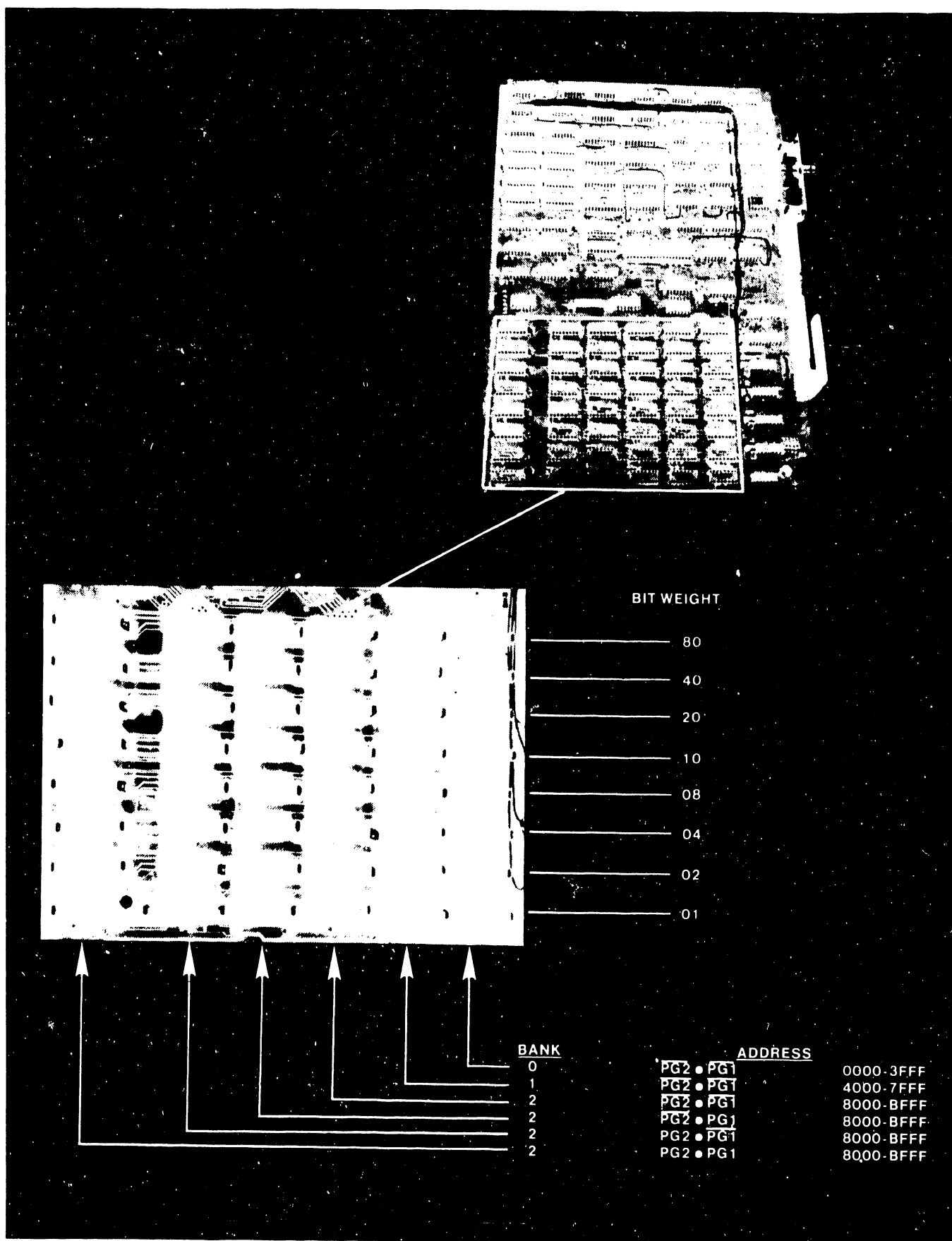

FIGURE 8-1 BOARD LOCATION OF MEMORY ADDRESSES-MODEL 5503 (2 OF 2)

Model 5504 (see Figure 8-2)

<u>Address Range</u>	<u>Bank No.</u>	
0000 - 3FFF	0/0	
4000 - 4000	1/0	
8000 - BFFF	2/0	($\overline{M2} \cdot \overline{M1} \cdot \overline{PG1} \cdot \overline{PG0}$)
8000 - BFFF	2/1	($\overline{M2} \cdot \overline{M1} \cdot \overline{PG1} \cdot PG0$)
8000 - BFFF	2/2	($\overline{M2} \cdot \overline{M1} \cdot PG1 \cdot \overline{PG0}$)
8000 - BFFF	2/3	($\overline{M2} \cdot \overline{M1} \cdot PG1 \cdot PG0$)
C000 - FFFF	3/0	($\overline{M2} \cdot \overline{M1} \cdot \overline{PG1} \cdot \overline{PG0}$)
C000 - FFFF	3/4	($\overline{M2} \cdot \overline{M1} \cdot \overline{PG1} \cdot PG0$)
C000 - FFFF	3/8	($\overline{M2} \cdot \overline{M1} \cdot \overline{PG1} \cdot \overline{PG0}$)
C000 - FFFF	3/C	($\overline{M2} \cdot \overline{M1} \cdot \overline{PG1} \cdot \overline{PG0}$)

Within a given row, the Xor data identifies the failing chip. In the case of a one-bit error, for example, should a written FF result in a readout of 7F, the Xor data would be 80 (hex). This would indicate that the failing chip is at bit-position D07 (see appropriate figure for memory layout - 5503 or 5504).

8.1.2 CRT MEMORY DIAGNOSTIC

The CRT Memory diagnostic tests address and data reliability on all of CRT memory, excepting the soft character font. The diagnostic includes the following tests:

<u>Test No.</u>	<u>Test Name</u>	<u>Hardware Tested</u>
01	Bank Addressing Test	Bank address and page select lines
02	Chip Addressing Test	Chip Address lines
03	Moving Inversion Test	Memory data test

8.1.3 Z80 INSTRUCTION SET

The Z80 instruction set test checks execution of all the instructions in the set. The test verifies operation of the following internal hardware.

- The accumulator with logic and rotate commands
- Three-bit multi-purpose registers
- The remainder of the rotate and shift commands
- The 16-bit register pairs using indirect addressing
- The exchange commands
- Index registers
- The stack pointer
- The push and pop commands
- The arithmetic group
- The bit test group
- The compare and block transfer group
- The call and set commands
- The indexed addressing mode

The test carries out each instruction at least once. An error check occurs at each stage during the test of an instruction. The test generates an error message if the data and/or flags are incorrect.

8.1.4 CTC DIAGNOSTIC

The CTC diagnostic tests the CTC chip and interrupt circuit on the CPU board. The tests are:

Test No.	Test Name	Hardware tested
1	Timer Mode	CTC, CPU Interrupt logic
2	Interrupt Priority	CTC interrupt daisy chain, CPU interrupt logic

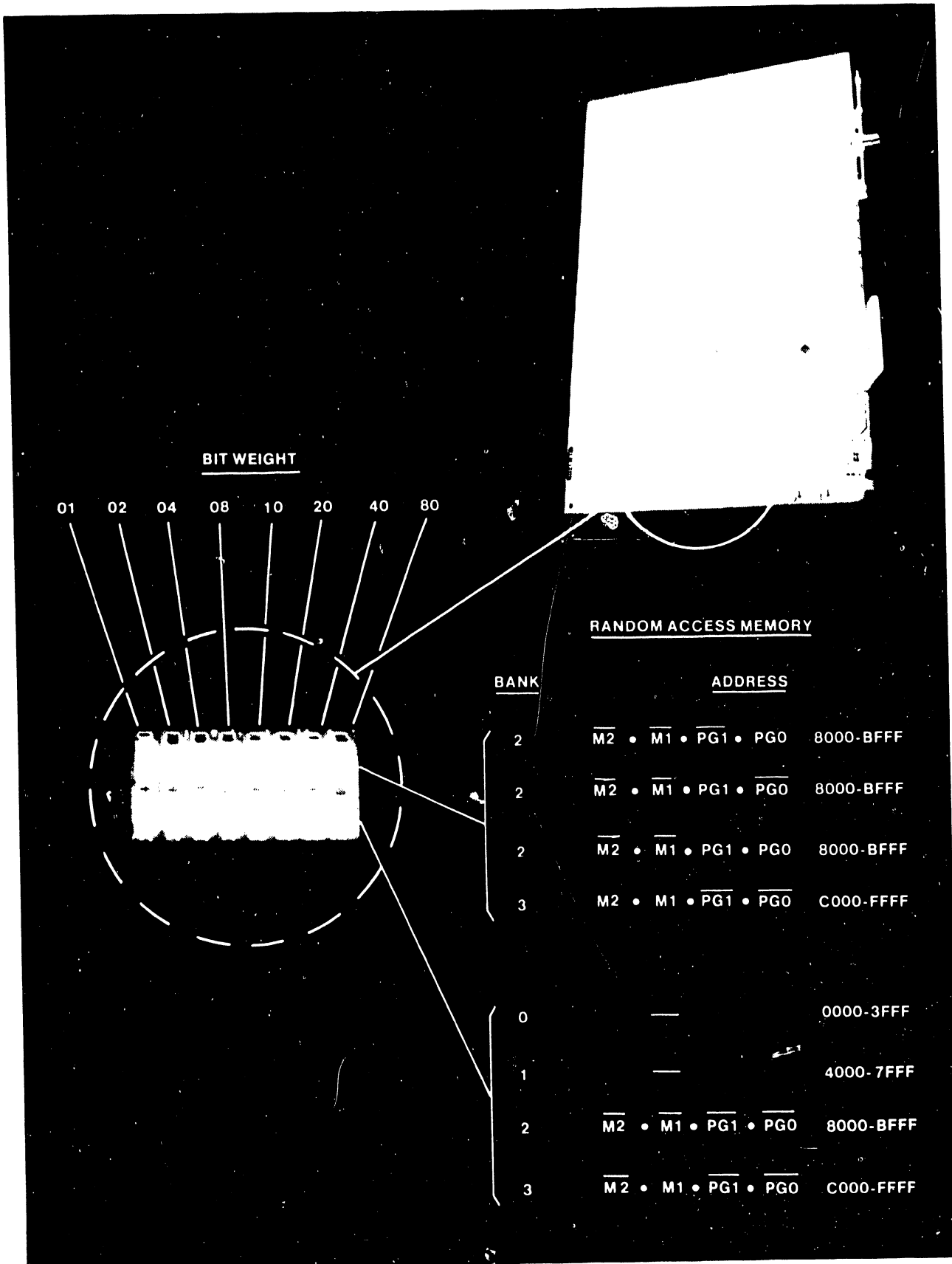

FIGURE 8-2 MEMORY ADDRESS CHIP LOCATION-MODEL 5504 (1 OF 2)

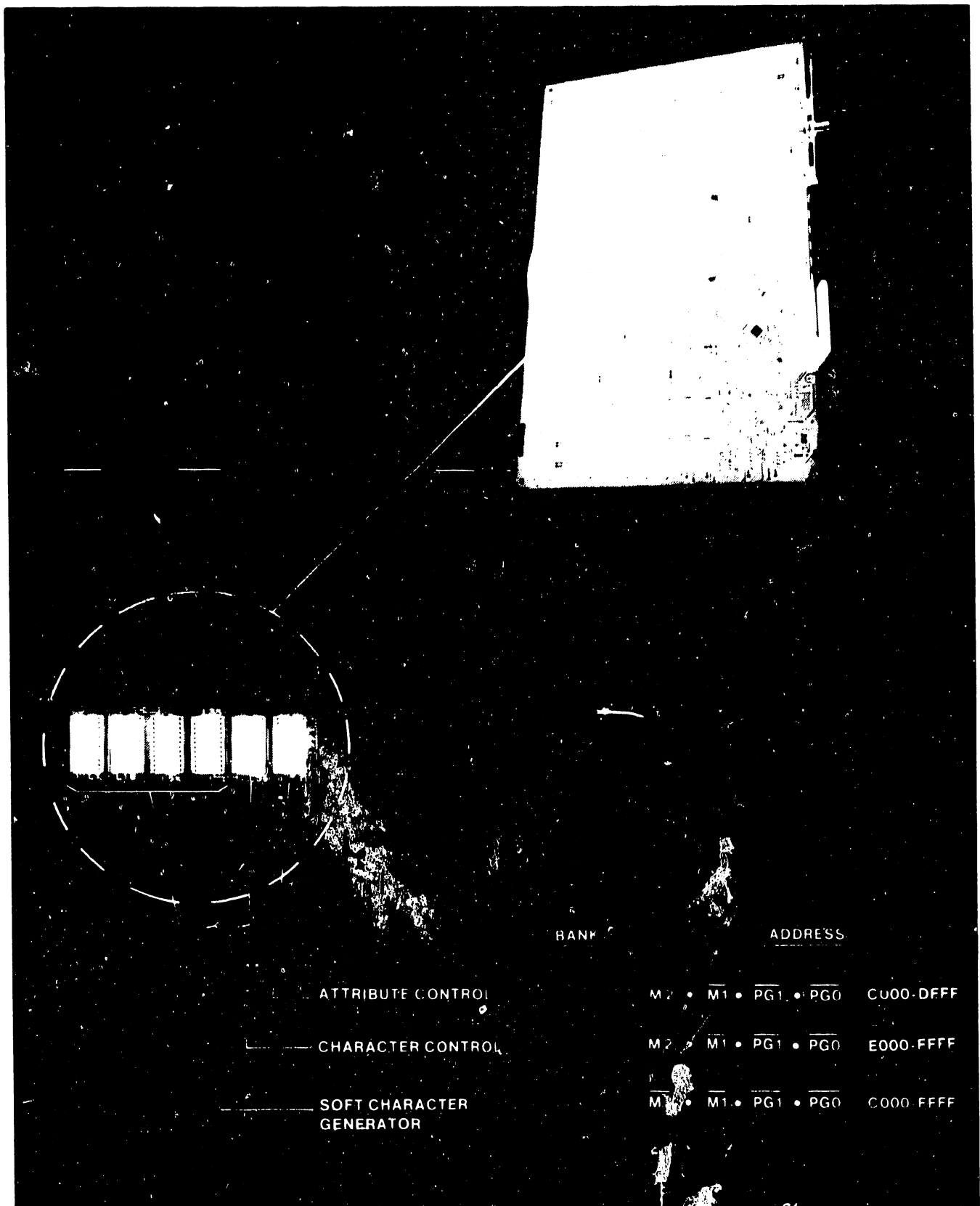

FIGURE 8-2 MEMORY ADDRESS CHIP LOCATION-MODEL 5504 (2 OF 2)

8.1.5 DISK

The Disk test checks the floppy disk controller (FDC on the CPU board), the disk drive, and cable. The tests are as follows:

<u>Test No.</u>	<u>Test Name</u>	<u>Hardware Tested</u>
1	Disk Reset	FDC (floppy disk controller), PIO
2	Disk Ready	FDC, ready signal
3	Track Zero	FDC, track zero signal
4	Cylinder Addressing	FDC, seek circuitry on drive
5	Forward Seek	FDC, seek circuitry on drive
6	Backward Seek	FDC, seek circuitry on drive
7	Format	FDC, disk drive
8	Read/Write	FDC, VCO, disk drive

If Switch 4 on the CPU board is ON (two disk drives in the system) the message portion of the run-time menu lists the options available for testing disk units 0 and 1:

- 0: To test unit 0, hit the 0 key, then hit EXECUTE
- 1: To test unit 1, hit the 1 key, then hit EXECUTE
- 2: To test both units 0 and 1, hit the 2 key, then hit EXECUTE

If switch 4 is OFF, unit 1 is effectively the only drive in the system, and the test selects unit 1 automatically.

Following drive selection, either manually or automatically, the menu calls for insertion of a scratch diskette into unit(s) under test. Press EXECUTE to start the test.

If disk unit 1 has been selected (with or without unit 0), an end-of-test message prompts to:

- 1) remove the scratch diskette from unit 1,
- 2) re-install the diagnostic diskette,
- 3) press EXECUTE (unless the loop on program option is in effect, in which case the end-of-test message does not appear).

8.1.6 DISPLAY AND KEYBOARD DIAGNOSTIC

The Display and Keyboard test checks elements of the keyboard, the CRT/memory and the CPU board. The test are:

<u>Test No.</u>	<u>Test Name</u>	<u>Hardware Tested</u>
1	Display Attributes Test	FDC (floppy disk controller), PIO and associated logic, CPU board
2	Keyboard Test	Keyboard assembly and keystroke logic on CRT/memory board
3	Soft Character Generator Test	Soft character generator memory on CRT/memory board and support elements on CPU board
4	CRT Adjustments	

Unlike the other system diagnostic tests, this diagnostic puts display patterns instead of a menu on the CRT. Some parts of the tests call for operator action.

Display Attributes (Figure 8-3)

The Display Attributes test generates a multi-line display. Each of the first nine lines shows the effect of turning on one attribute only. The next to last line (SCRIPT COMPARISON) shows (in order): subscript, no attribute, superscript, and double superscript, to produce the effect of a smoothly rising line of characters. The line then moves smoothly down to produce an overall effect of a wavy line. The last line shows various characters generated by the soft character memory.

Applications of the various attributes progress repetitively across the display, left to right. Figure 8-3 shows the sweep: part way (A) and full way (B) across the display.

To perform the test:

1. Observe that all attributes affect the display as called for by the pattern.
2. Observe that all dots within the matrices displayed from the soft character generator turn both on and off within the various patterns.
3. Exit from the test by pressing both the SHIFT and CANCEL keys at the same time.

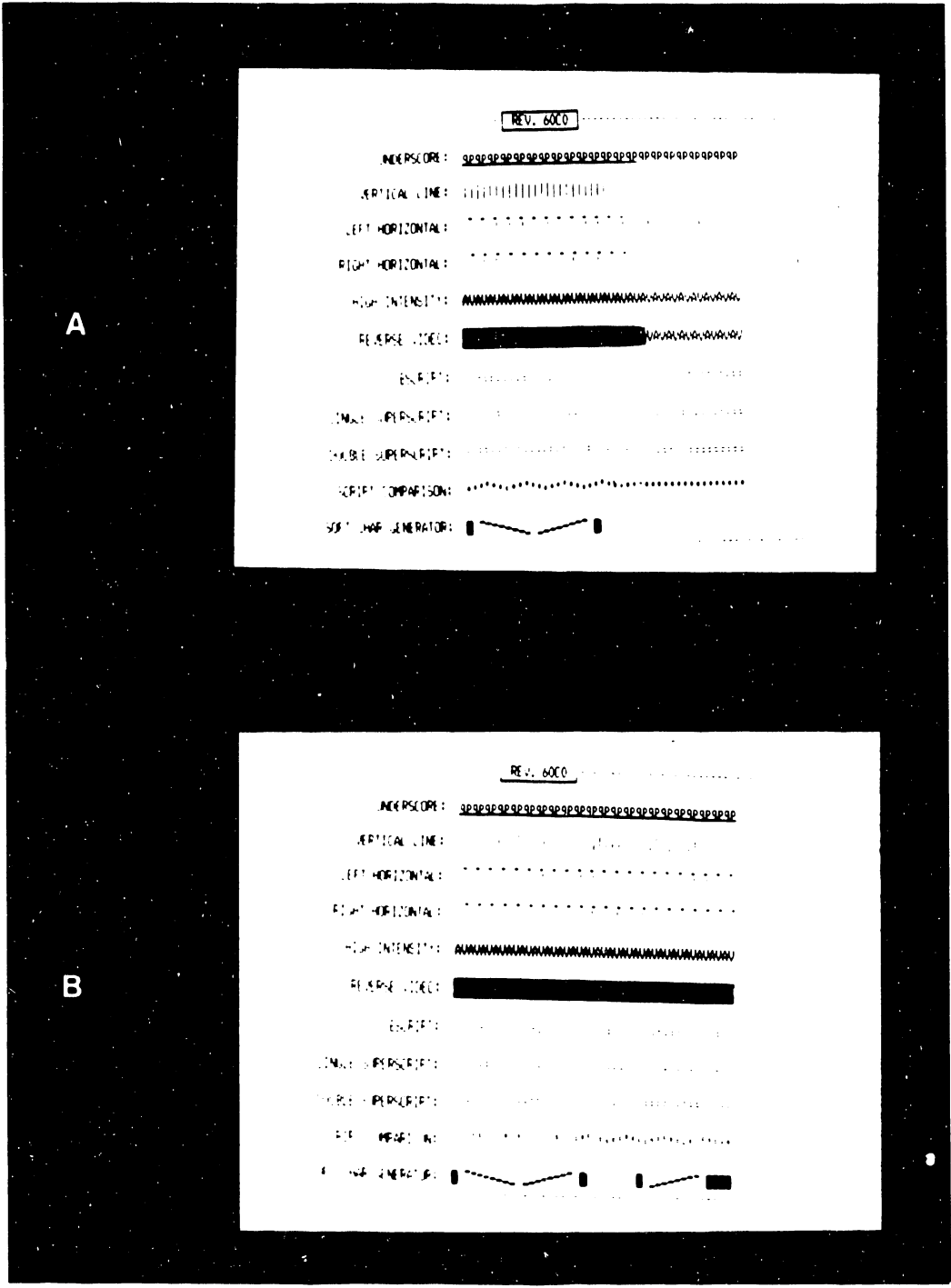

A

B

FIGURE 8-3 DISPLAY ATTRIBUTES

Keyboard Test (Figure 8-4)

Pressing the SHIFT-CANCEL keys (or any unshifted key) during the Display Attributes test starts the Keyboard test. The Keyboard test displays a representation of the keyboard. This test requires operator action:

1. Press the first key to be highlighted twice (uppermost left in the display). The key to the its immediate right should also highlight.
2. Repeat step 1 for each highlighted key thereafter throughout the display. Notice that in some instances, the shift key is pressed at the same time.

If an incorrect keystroke is detected, the key that corresponds to the incorrect keycode flashes, and an error message is displayed (see Figure 8-4). If the incorrect keycode does not correspond to any existing key, no key flashes; however, the error is displayed.

Soft Character Generator Memory (Figure 8-5)

Pressing the SHIFT-CANCEL keys, during the Keyboard test starts the Soft Character Generator Memory test. The Soft Character Generator Memory test displays sixteen character blocks. Each block is labeled to show the particular memory address. Until modified by a keystroke, the generator writes that portion of memory with alternative entries of all F's and O's. The visual effect is that of 128 blocks alternating every 5 seconds with blanks. This alternating displays permit a checking that no bits (dots) stick in either the ON or OFF state.

1. Press any key other than SHIFT-CANCEL to freeze the display when the blocks are ON. The top left block is raised to show it is selected for modification. Use the cursor control keys to select other blocks for modification (see Figure 8-5).
2. Press the seven command keys at the top left of the keyboard, one after another, to toggle the seven bits in the line of the selected block. One line in the selected block should blank out.
3. Press the space bar to select other lines within the selected block. Each time the space bar is pressed it selects the next lower line, cycling back to the top line after selection of the bottom line.
4. Press SHIFT-CANCEL to terminate the test.

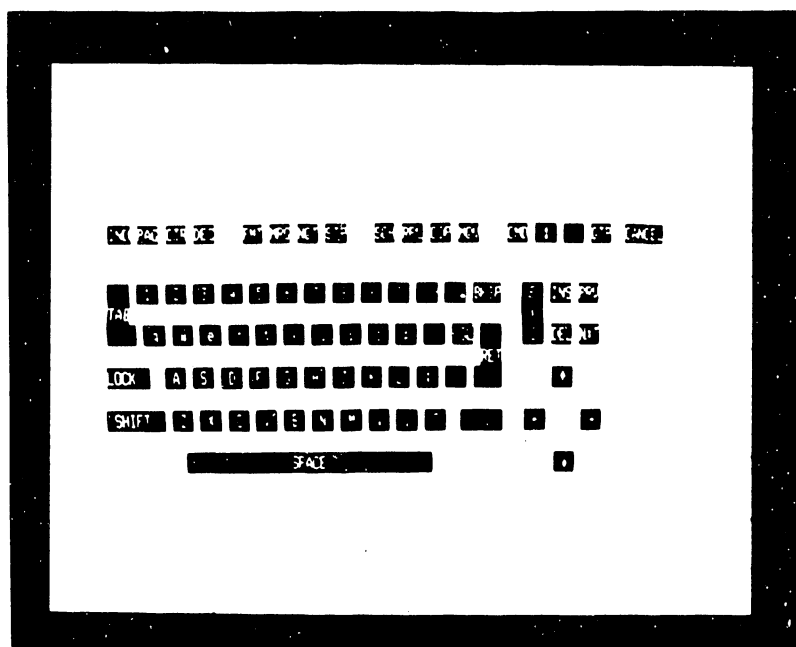

FIGURE 8-4 KEYBOARD TEST

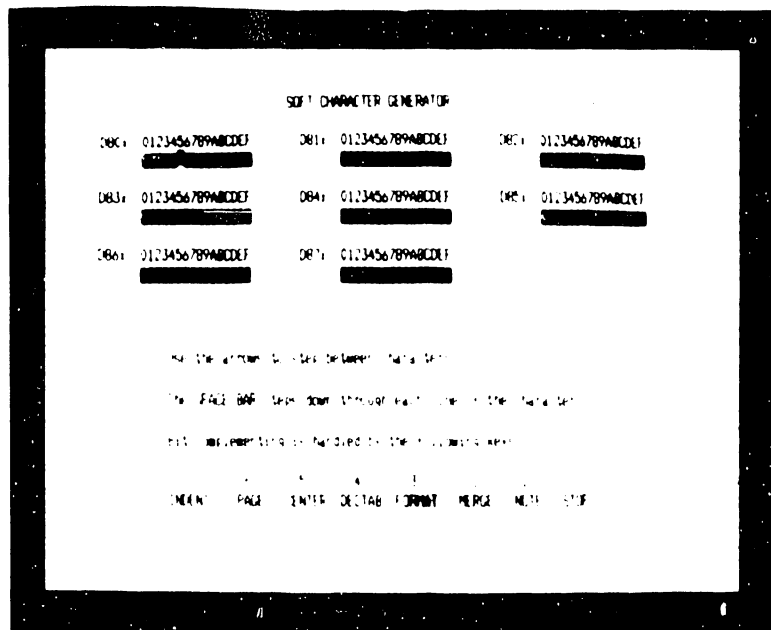

FIGURE 8-5 SOFT CHARACTER GENERATOR MEMORY TEST

8.1.7 LAMP AND STATUS DIAGNOSTIC

The lamp and status diagnostic tests:

- Printer panel switches, lamps sensors, character counter
- Seven-segment display
- Slave type (IN07) switch bank
- Associated cables

The test creates screen displays (following) which indicate the condition of printer switches and sensors, and of the slave-type switch bank. To identify the status of a switch, select (press) it and observe the effects on the menu.

MESSAGE AREA OF THE MONITOR

Panel Switches	SEL	RU	RD	FU	FD	TOF	PL
	ON	OFF	OFF	OFF	OFF	OFF	OFF
Status Switches	RM	LM	RO	PO	CO	DH	RT
	OFF	OFF	OFF	OFF	OFF	OFF	OFF
Slave Type Switch		0 0	1 1	1 1	1 1		
		(Bits	1 2	3 4	5 6	7 8)	

The abbreviations (Menu ID) used in the Panel Switches section above are:

<u>Panel</u> <u>Switch Name</u>	<u>Menu</u> <u>ID</u>	<u>Associated</u> <u>Indicator</u>
Select Key	SEL	Select Lamp
Roll Up	RU	Change Ribbon Lamp
Roll Down	RD	Change Paper Lamp
Line Feed Up	FU	Error Indicator
Line Feed Down	FD	Change Daisy Lamp
Top of Page	TOF	Character Counter
Paper Load	PL	N O N E

The OFF/ON menu indication refers to the expected condition of the associated indicator. Thus, the ON shown below the SEL in the menu indicates that the select lamp should be lighted. Each time a panel switch is pressed, with the exception of the TOF and FU switches, both the indicator and the associated menu representation should change condition from OFF to ON.

The TOF switch controls the character counter at the rear of the unit. Each time the TOF switch is pressed, the counter should increase by one.

The FU switch controls the seven-segment error display at the rear of the unit. Continuous pressing of the FU switch first banks the display, then lights individual segments in the following sequence.

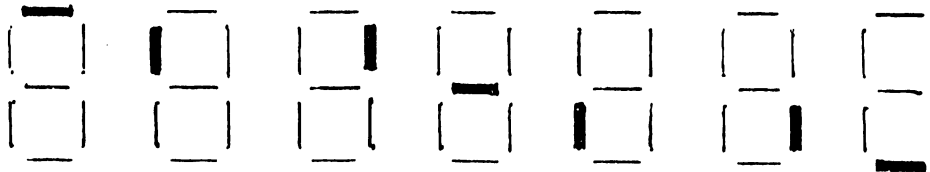

The abbreviations and their associated sensors used in the Status Switches section of the menu are:

<u>Sensor Name</u>	<u>Sensor Menu Id Code</u>
Right Margin	RM
Left Margin	LM
Ribbon Out	RO
Paper Out	PO
Cover Open	CO
Daisy Home	DH
Ribbon Type	RT

Blocking RM, LM, RO, and DH with an opaque material causes the menu to display an ON condition for the associated status switch; an unblocked sensor results in an OFF indication.

PO is ON when not blocked, RT is OFF with switch enabled; and CO is OFF with cover closed (enabled).

The Slave Type Switch selection of the menu displays either a 1 (OFF) or a 0 (ON) to indicate the condition at the given position (as shown on the plastic case of the switch bank).

8.1.8 PRINTER DIAGNOSTIC

The Printer Diagnostic tests electrical and mechanical printer functions for alignment. The diagnostic displays three secondary menus which can be selected from the principal printer menu:

- Mechanical - Checks printer assembly functions. Make mechanical alignments during the test, if necessary.
- Print - Checks the ability of the printer to maintain consistent print quality throughout various configurations. No adjustments are required during the test.

Burn In - Check maintenance of repetitive electrical and mechanical functions for a duration selected by the operator. No adjustments are required during the test.

When the Printer test is selected from the system main menu, the following menu appears on the monitor:

- (1) Test Selection (0=ALL) (1=Mechanical) (2=Print) (3=Burn In)
- (2) Type of test (0=Conf) (1=QA Acceptance)
- (3) Pitch Selection (0=10) (1=12 N/A)
- (4) Paper form (0=Single sheet) (1=Con-Form)

0.....0.....0.....0.....

To select a routine:

Press RETURN to move the cursor between fields (between successive 0's in the bottom line of the menu)

Enter number corresponding to select an option for that field; e.g., for the Test Selection (1) field, enter 1 to select the Mechanical test. A field left blank, defaults to option 0 for that field.

The following paragraphs summarize the options in each field:

(1) Test Selection:

(0=ALL) - Starts automatic running of print tests . At the conclusion of the print tests, the monitor displays the menu for the mechanical tests.

(1=Mechanical) - Displays the menu for the mechanical tests.

(2=Print) - Displays the menu for the print tests.

(3=Burn In) - Starts the routine to exercise the printer functions, with a minimum of actual printing.

(2) Type of test:

(0=Conf) - Limited (short) printer tests.

(1=QA acceptance) - In-depth printer tests.

(3) Pitch Selection:

(0=10) - Tests printer in 10 pitch (10 characters per inch; 80 characters per line).

(1=12) - Not available.

(4) Paper Form

(0=Single Sheet) - Stops test periodically and prompts for new sheet of paper.

(1=Con-Form) - Runs the tests continuously, which requires continuous-feed paper.

8.1.8.1 Mechanical Test

When the Mechanical test is selected (Test Selection, option 1), the monitor displays the following menu:

Desired Adjustment Tests

(1) Ribbon Advance	(4) Ribbon Adjust	(7) Paper Eject
(2) Hammer Impact	(5) Daisy H-Sensor	(8) Burn In
(3) Mech Align	(6) LM Sensor	(9) Print Menu

0.....

To perform the mechanical tests:

1. Load paper into the printer.
2. Enter option number, as shown in the menu, and press EXECUTE.
3. Follow message prompts.
4. Exit from individual tests by following message prompts or pressing CANCEL. Pressing CANCEL causes a return to the main System Diagnostic menu display from which the Printer Diagnostic menu may be re-accessed.

The following notes apply to the individual tests:

Test 1 - Ribbon Advance:

Verifies electrical and mechanical requirements for ribbon motion and control. The printer impresses seven patterns onto the ribbon (see following illustration). The period preceding each pattern indicates that a new distance has been selected.

. 11111 . 1 1 1 1 1 . 1 1 1 1 1 . 1 1 1 1 etc.

Test 2 - Hammer Impact:

Verifies electrical and mechanical aspects and their associated software. Message prompts define operator action. The printer prints one line of data first with the lowest intensity of the hammer (one-fifth maximum power), then a second line at two-fifths maximum, and finally progressing to highest intensity (maximum power) in the last line.

Test 3 - Mechanical Alignment:

When selected, the program prints a repetitive four-line pattern and runs continuously until the printer is de-selected.

Test 4 - Ribbon Adjust:

Verifies that the ribbon carriage assembly is properly positioned so that the print is vertically centered on the ribbon. Testing involves removing the ribbon to observe the placement of the character impressions. See Chapter 5 for description of ribbon height adjustment.

Test 5 - Daisy Home Sensor Test

The daisy wheel must be installed prior to the running of this test.

Enables checking and adjusting the Daisy home sensor. The program places the carriage mechanism in the center of the travel path and displays the following pattern:

```

4 3 2 1 8 7 6 5 4 3 2 1 H 7 6 5 4 3 2 1 8 7 6 5 4 Motor Step Ref
0 0 0 0 0 0 0 0 A 1 1 1 1 1 1 1 1 1 1 1 1 0 0 0 0
      A A A A A

```

Align the A's as shown above by moving photo sensor (see paragraph 5.2.1.1 for mechanical details). Should character selection be off by 2 (or a multiple of 2), readjust the sensor to place under motor step 3, or 2.

Select the printer

A non-vertical alignment of the two A positions indicates need for home sensor adjustment. Continue to adjust and re-select until the vertical alignment of the two A is correct.

NOTE

If CP/M Software is used, verify that it prints correctly. CP/M may require that the sensor be adjusted under Motor Step 3, 2, or 1 to enable printing via both WP and CP/M. Thus:

```

. . 5 4 3 2 1 . . .
. . 0 0 A 1 1 . . .

```

Test 6 - Left Margin Sensor Adjust Test

Enables checking and adjusting of the left margin sensor. The program moves the carriage to the right, then returns the carriage to the sensor and displays the following :

```

4 3 2 1 8 7 6 5 4 3 2 1 H 7 6 5 4 3 2 1 8 7 6 5 4
1 1 1 1 1 1 1 1 1 1 1 1 1 B 0 0 0 0 0 0 0 0 0 0
                                B

```

Align the B's

Select the printer

A non-vertical alignment of the two B positions requires adjustment of the left margin sensor adjustment. Continue to adjust and re-select until vertical alignment of the two B positions is correct.

Test 7 - Paper Eject:

Checks paper ejection from the printer into the holder under the printer housing.

Test 8 - Burn In:

See description of Burn In test in paragraph 8.1.8.3.

Test 9 - Print Menu:

This option allows direct selection of the Print menu from the Mechanical test without returning to the System Main menu. For a description of Print test options, see paragraph 8.1.8.2

8.1.8.2 Print Test

Selection of the Print test (option 2 of the Printer Diagnostic main menu), displays the Print Test menu:

(1) Data Buffer	(5) Char. Set	(9) H-Motion
(2) Spiral Pat.	(6) Line Buffer	(10) V-Motion
(3) Underscore	(7) Worst Case	(11) Std Page
(4) Overstrike	(8) Paper Tension	(12) Mech Menu

0.....

Options may be selected either individually, by entering the appropriate option number, or as a group, by pressing EXECUTE. The following notes apply to the individual tests:

Test 1 - Data Buffer Test:

Verifies that all major bit patterns print out the correct character. Prints five lines of each seven-bit pattern (long version) or one line of each pattern (short version).

Test 2 - Spiral Pattern Test:

Checks that there is no interaction between the internal print buffer, the data bus, and the printed character ASCII code. Test prints five lines (short version) or a number of lines equal to the width of the print sample (long version).

Test 3 - Underscore Test:

Verifies that the underscore character overlaps and makes one continuous line across the page.

Test 4 - Overstrike Data:

Verifies that the printer overstrikes correctly in all modes.

Test 5 - Character Set:

Verifies the printing of all characters on the printer daisy wheel.

Test 6 - Line Buffer:

Verifies the line-length of the printer. The printer prints two lines: first from left to right, and then from right to left. Each line consists of the series, 123456789-, repeated for the full length of the paper. The number of dashes, multiplied by 10, plus the highest number in the last incomplete series, equals the complete character count. This total should agree with the printer width specification in Chapter 1 of this Manual.

Test 7 - Worst Case Pattern:

Checks the recovery speed for printing characters on opposite sides of the print wheel, and between other positions along the wheel. The test prints four lines of "worst case."combinations.

Test 8 - Paper Tension:

Checks that all the paper-holding functions are working properly. The test prints a full line of characters from left to right, then overprints from right to left. Between characters, the test either advances or backs up the roller by a quarter of a line.

Test 9 - Carriage Motion Data:

Verifies accuracy of the stepping motor and associated electrical and mechanical hardware.

The printer prints a vertical reference bar, then moves a distance representing one degree of stepping-motor movement. The printer prints a vertical bar at this point and returns to the original reference point to repeat the procedure. Repetitions of this test show the following pattern:

CARRIAGE MOTION DATA TEST

Double Bit Distances



Cumulative Bit Distances



The space between each succeeding set of vertical bars doubles, which reflects the increase in the significance of each succeeding control bit.

Test 10 - Vertical Movement:

Verifies the accuracy of the paper-advance stepping motor and its associated electrical and mechanical hardware. The relationship between the control data input and motor movement for this test is identical to that of Test 9, although the printout shows a vertical, instead of horizontal, set of reference marks (see the following illustration).

VERTICAL MOVEMENT TEST

```

-----
  -----
    -----
      -----
        -----
          -----
            -----
              -----
                -----
                  -----
                    -----

```

Test 11 - Standard Page:

Tests print quality with a single-page reproduction of the print quality standard developed by the New Products Quality Control Engineering Department.

Test 12 - Mech Menu:

Allows inter-menu changing without the cancelling out of the program.

8.1.8.3 Burn-In

The burn-in can be selected from either the main Printer Diagnostic menu or the Mechanical Test menu. The system automatically defaults to the burn-in program if no other selection is made within 30 seconds of selecting the System Diagnostic diskette. When burn-in starts, by either selection or default, the program automatically goes to the Confidence test, in 10 pitch with a single strike ribbon. The test permits paper loading, but requires no further operator intervention.

8.1.9 VCO Adjustment

The equipment should operate for 15 minutes preceding the test to ensure validity of the following observations. For removal of right side panel, for access to the CPU board, refer to Chapter 5.

Model 5503:

VCO adjustments are made via the VCO adjustment pot R2 (CPU PC board, lower left quadrant).

1. Observe test display. For message: GOOD STATUS Returned from READ ID operation (good status) - go to step 3. For message: DISK CONTROLLER TIME OUT (bad status) - go to step 2.
2. Note VCO adjustment pot (CPU PC board, lower left) setting. Adjust alternately CW or CCW (full turn, maximum) to obtain good status indication. Go to step 3.
3. Note pot setting. Slowly adjust R2 CW until test displays a bad-status message: DISK CONTROLLER TIME OUT
4. Slowly adjust R2 CCW until good status message appears. Note position of the setting.
5. Adjust R2 CCW to obtain a bad-status message, then return adjustment (CW) to point at which a good-status indication reappears. Note position of the setting.
6. Set R2 equidistant (usually a half turn) between the two settings.
7. Reload customer software and verify system operation.

Model 5504:

The VCO circuit on the Model 5504 is field adjustable via a test procedure described in Chapter 5. The PC board (210-7977) must be replaced should a bad-status indication, DISK CONTROLLER TIME OUT, appear.

8.1.10 FTC BOARD DIAGNOSTIC

The FTC board diagnostic comprises the following tests:

<u>TEST NO.</u>	<u>TEST NAME</u>
1	CTC Timer Test
2	CTC Priority Test
3	
.	
	SIO Tests 1 through 9
.	
11	
12	DMA STATUS Test
13	DMA Register Select Test
14	DMA Register Data Test

FTC Board Diagnostic Tests (continued)

<u>TEST NO.</u>	<u>TEST NAME</u>
15	DMA Memory Transfer
16	Dual Channel Rx Tx
17	TC + Memory to Memory
18	TC + Memory to I/O
19	TC + I/O to Memory

Upon initialization, the diagnostic will display the following message:

1. Replace DIAGNOSTIC diskette in drive 01 with SCRATCH diskette.
2. Select 'Loop on Program'
3. Select Loopback: ENTER ...
 - 0 = All
 - 1 = RS232
 - 2 = RS449
 - 3 = X.21
 - 4 = no loopback

After selections are made, a pressing of EXECUTE initiates the program. The program runs continuously until either it is terminated or an error is detected. Should no loopback be selected, tests 6 through 11 and 16 through 19 will not run. If more than one loopback is selected, the loopback tests will run in the order shown in the menu (i.e., RS232, RS449, X.21).

8.2 POWER DISTRIBUTION

Figure 8-6 shows a simplified system power distribution; analysis of interdependencies in the derivation of various voltages may be of aid in the tracing of power-supply problems (e.g., a failure of the +36-volt supply would impact both the +12-volt and +5-volt supplies). Similarly, observation as to which components depend upon which power distribution branches may aid in isolating the given fault.

8.3 TROUBLE ANALYSIS (TA) FLOWCHARTS

The flowcharts contained in this chapter provide analysis of failures possibly observed from system checkout procedures (Chapter 4).

8.3.1 CRT FAILURE (see TA-1)

Trouble Analysis chart No. 1 provides trouble analysis after initial checks, via the power-up checkout, have established presence of primary power and integrity of primary fuses, but with the CRT remaining dark. Remedial steps outlined in the chart should ready the system for resumption of the power-up checkout (Chapter 2).

8.3.2 PRINTER FAILURE (see TA-2)

Trouble Analysis chart No. 2 provides trouble analysis after the power-up checkout has verified performance of all system components, excepting the printer. TA-2 therefore confines the analysis to the Printer Driver PCA Board and the printer, plus associated cabling connections.

In addition to steps specified by the chart, inspection should be made of all connectors, especially the cable connectors which move with the print head assembly.

8.3.3 PRINT QUALITY TROUBLESHOOTING

The following comprises a troubleshooting checklist for correcting print quality deficiencies. Refer to Chapter 5 for printer adjustments called out.

<u>PROBLEM</u>	<u>EXPLANATIONS/ADJUSTMENT(S)</u>
1. Underscore choppy	Either: Hammer not centered on the petal - go to Problem 2
	OR
	Daisy wheel petal, at home position, not perpendicular to the printed line.
	Loosen four screws at the rear of the head that mount the daisy motor. Rotate motor in the direction necessary, and re-tighten (if underscore left is lower than the right, rotate top of the motor to the right and vice versa).

Print quality troubleshooting continued following text -

NOTE: POWER SUPPLY SHOWN IS FOR MODEL 5503 ONLY

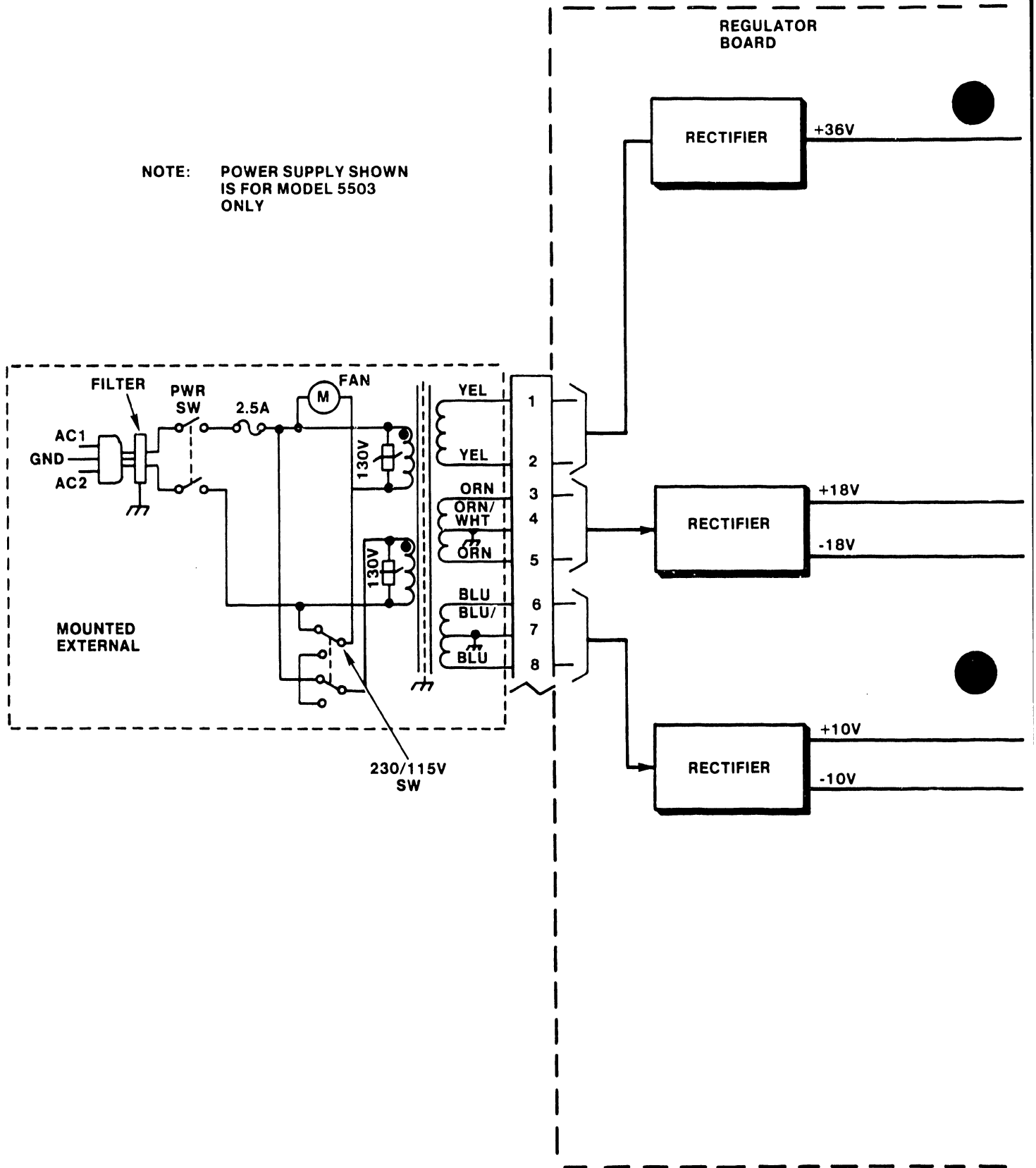

FIGURE 8-6 SYSTEM POWER DISTRIBUTION (1 OF 5)

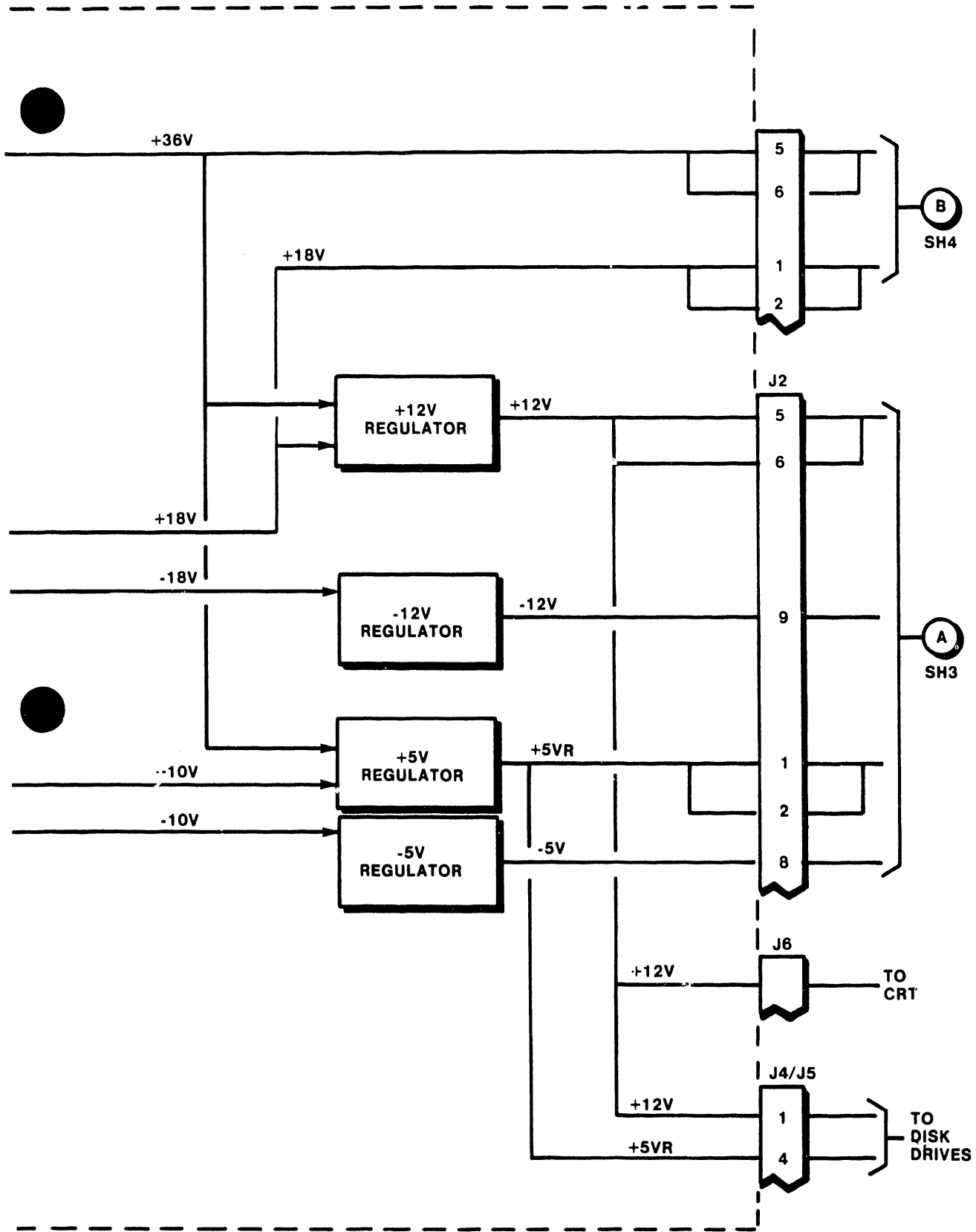

FIGURE 8-6 SYSTEM POWER DISTRIBUTION (2 OF 5)

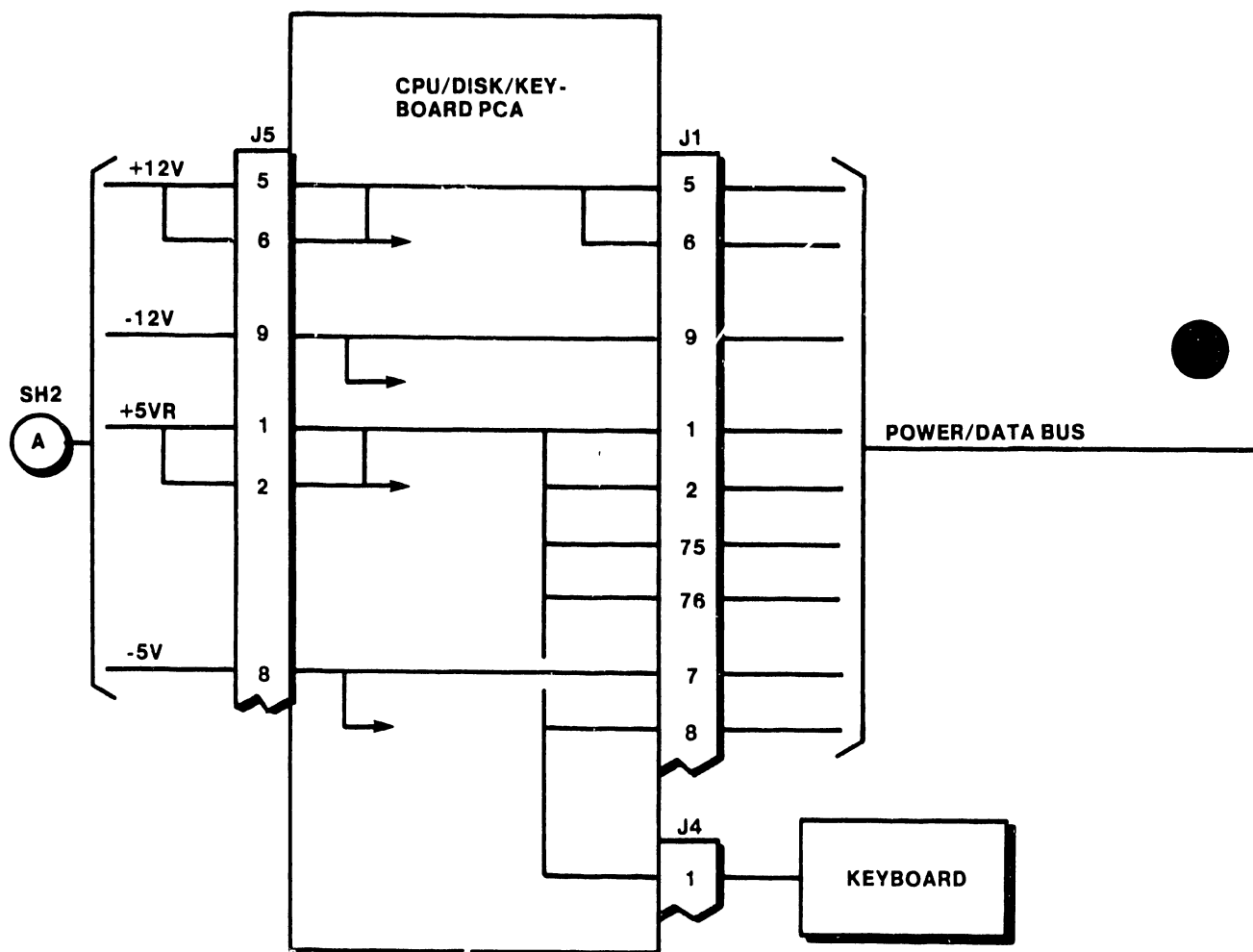

FIGURE 8-6 SYSTEM POWER DISTRIBUTION (3 OF 5)

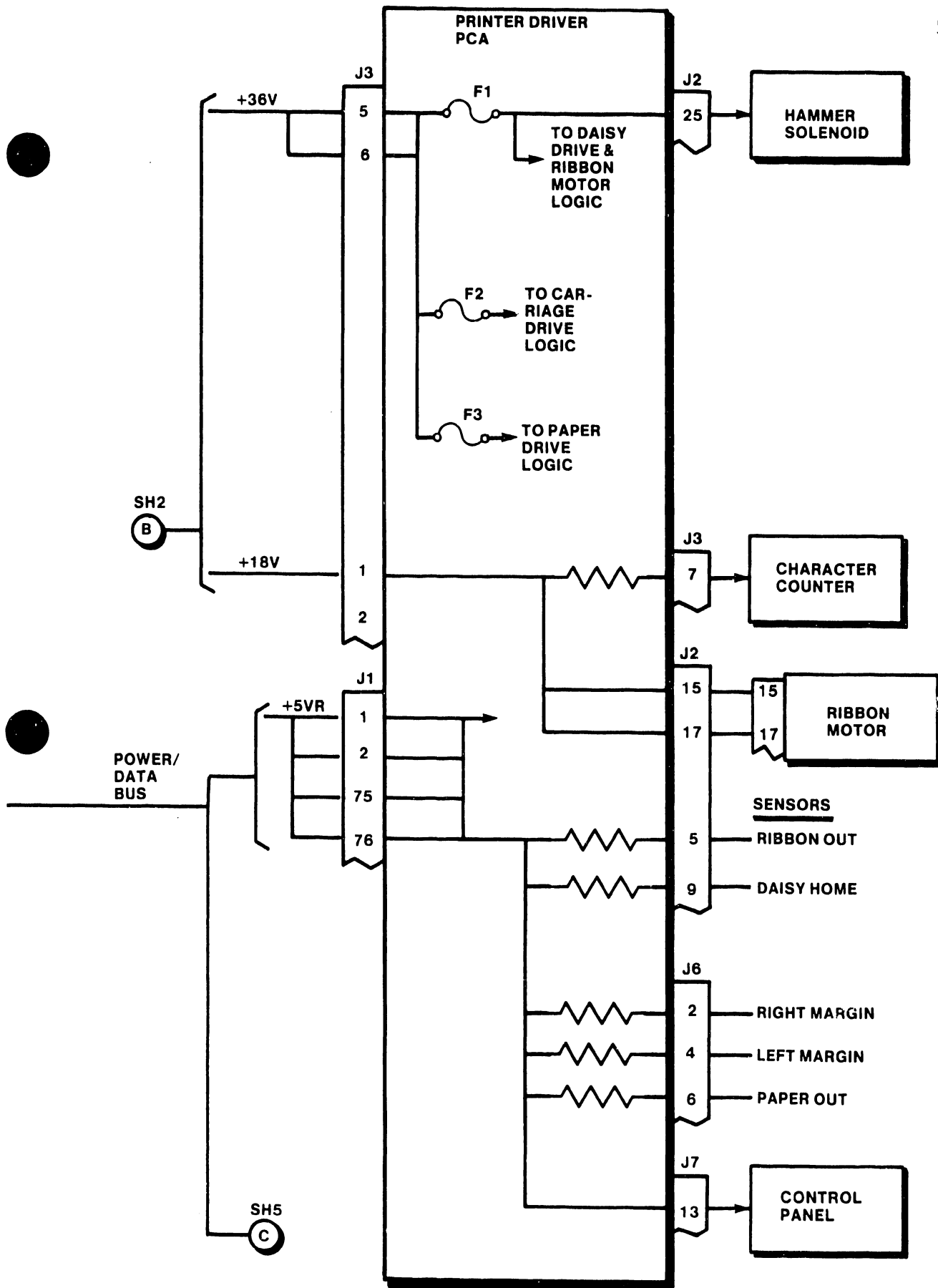

FIGURE 8-6 SYSTEM POWER DISTRIBUTION (4 OF 5)

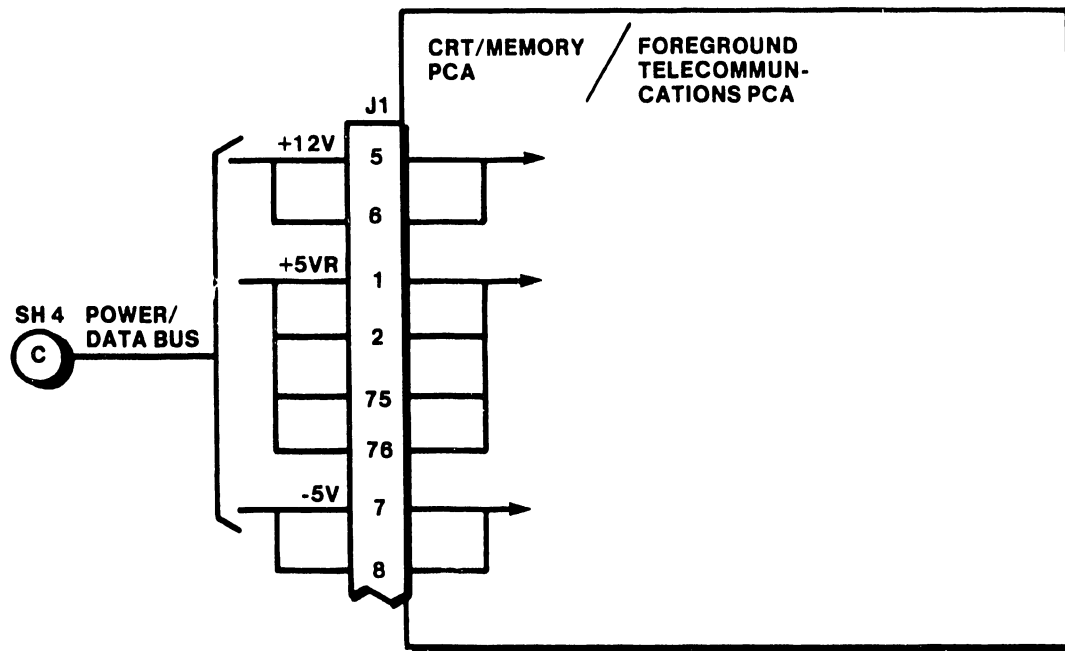

FIGURE 8-6 SYSTEM POWER DISTRIBUTION (5 OF 5)

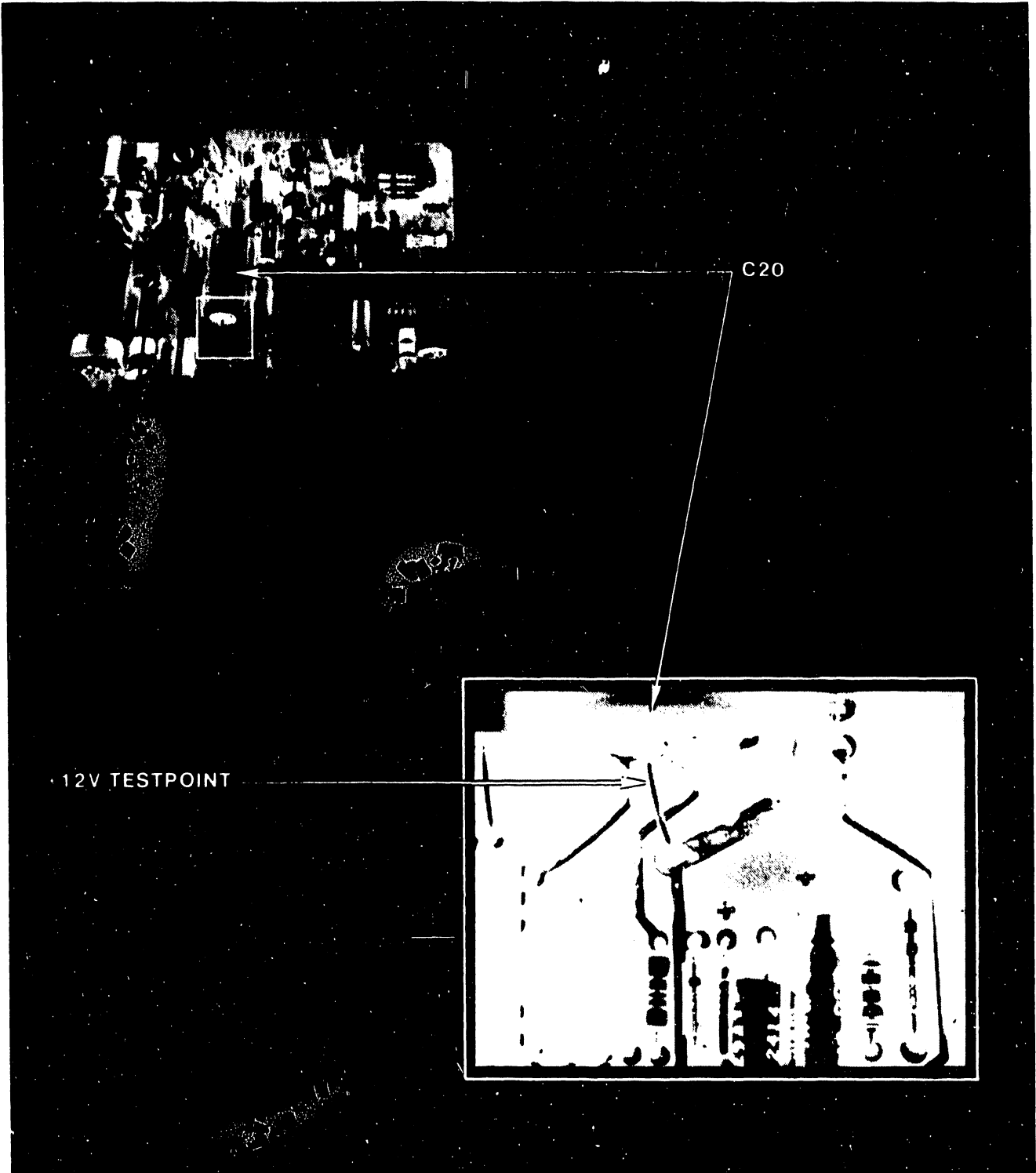
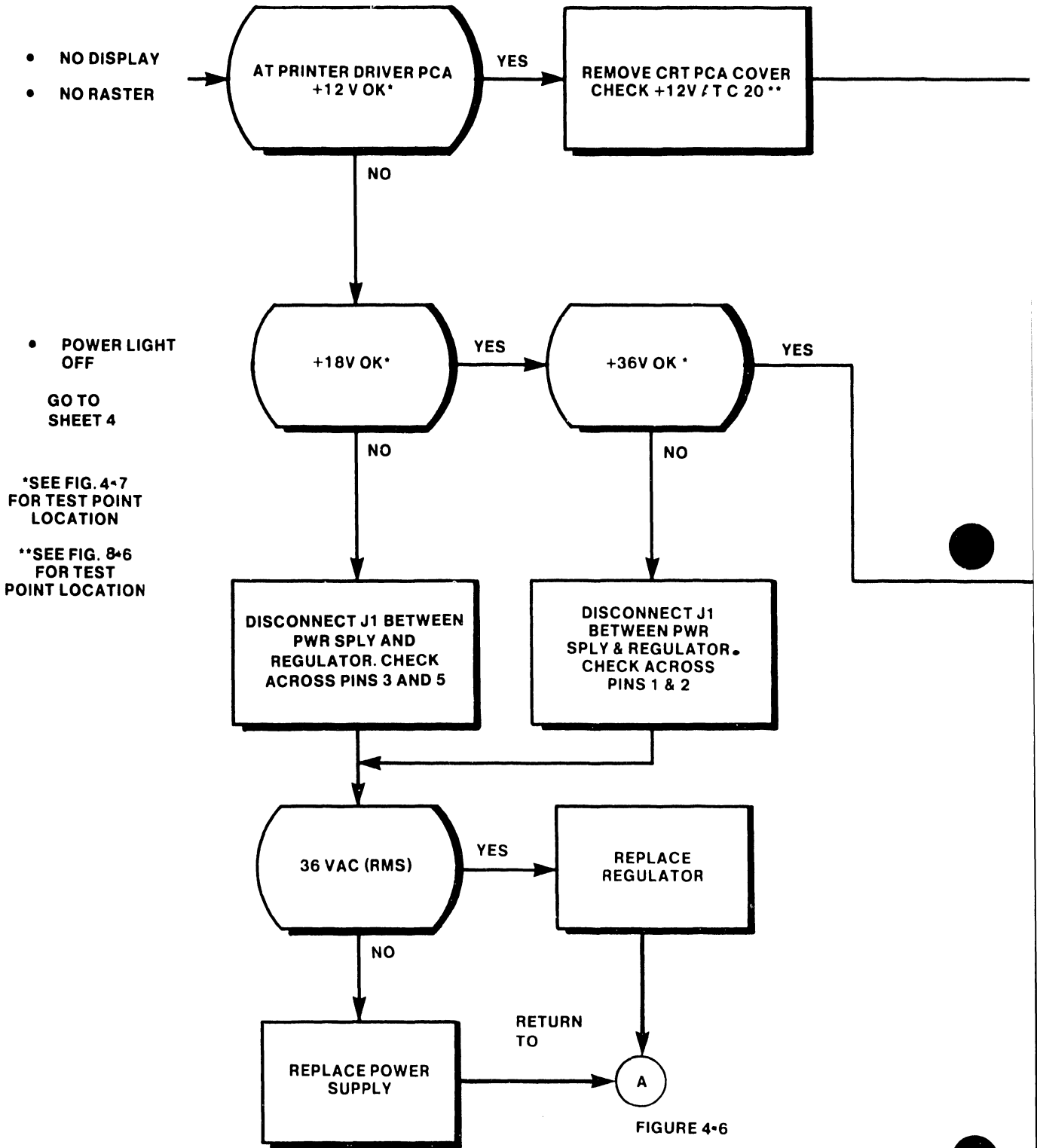
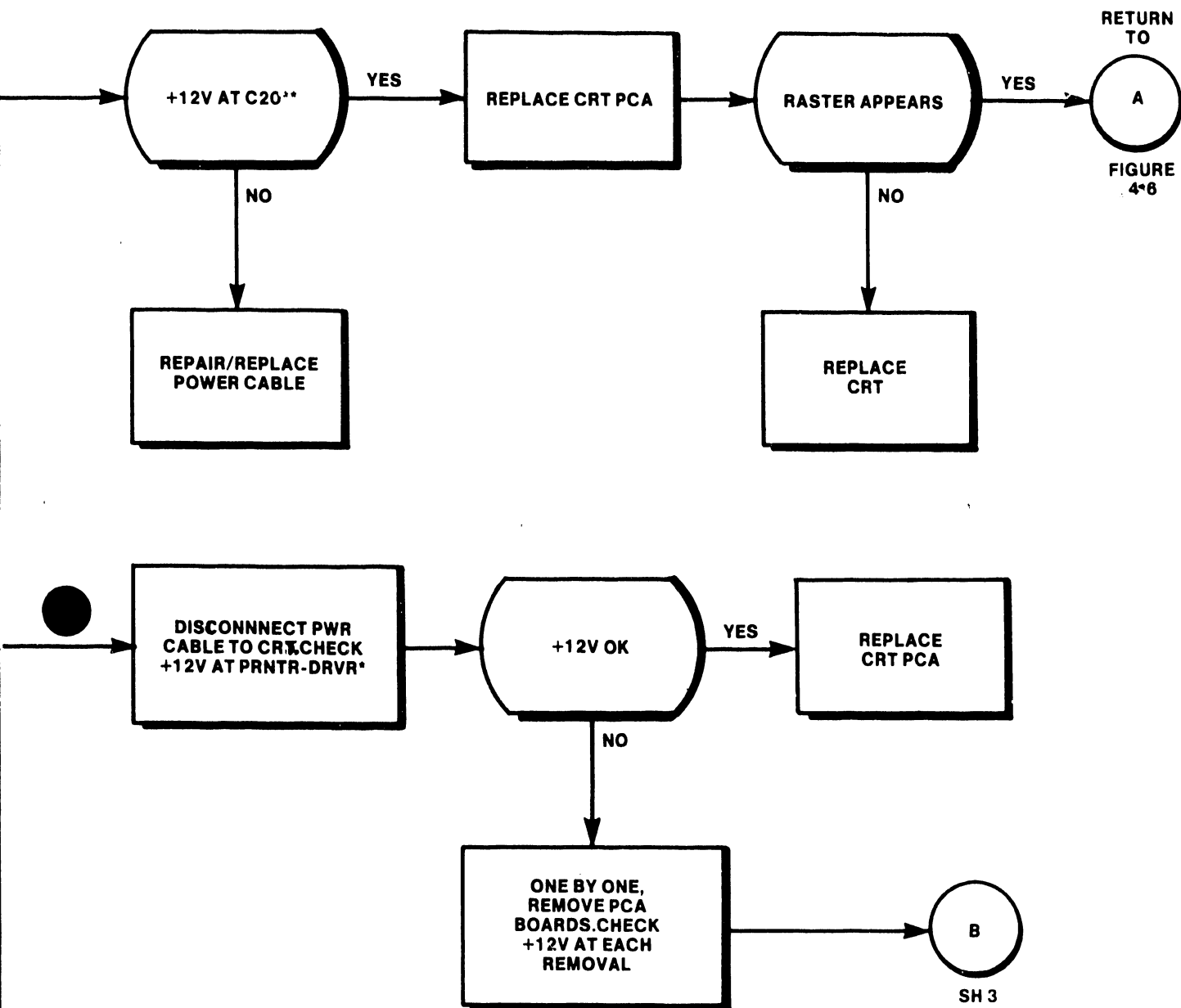

FIGURE 8-7 CRT PCA + 12VTEST LOCATION

TA-1 CRT FAILURE (1 OF 4)



TA-1 CRT FAILURE (2 OF 4)



TA-1 CRT FAILURE (3 OF 4)

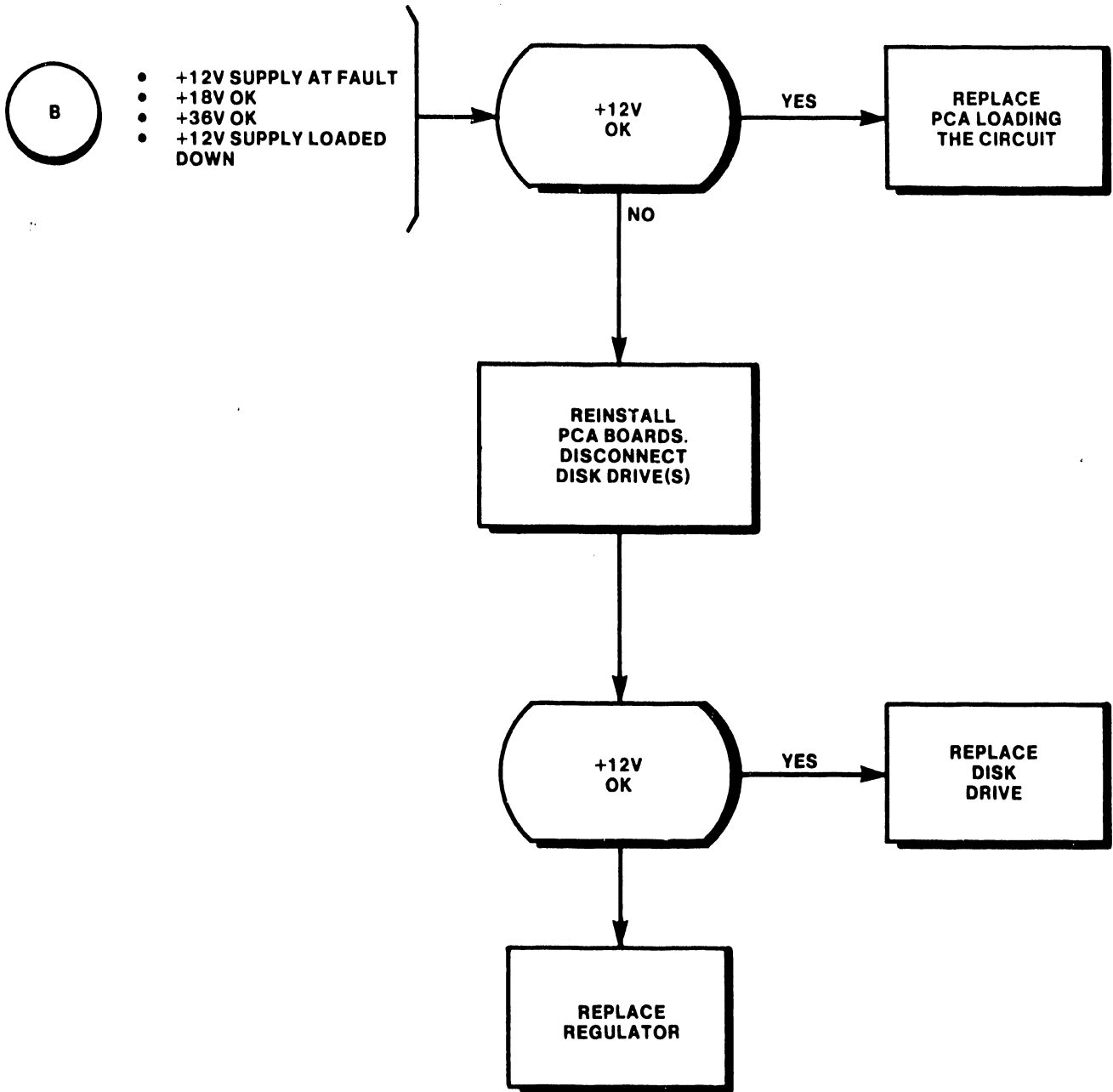

TA-1 CRT FAILURE (4 OF 4)

- POWER LIGHT OFF

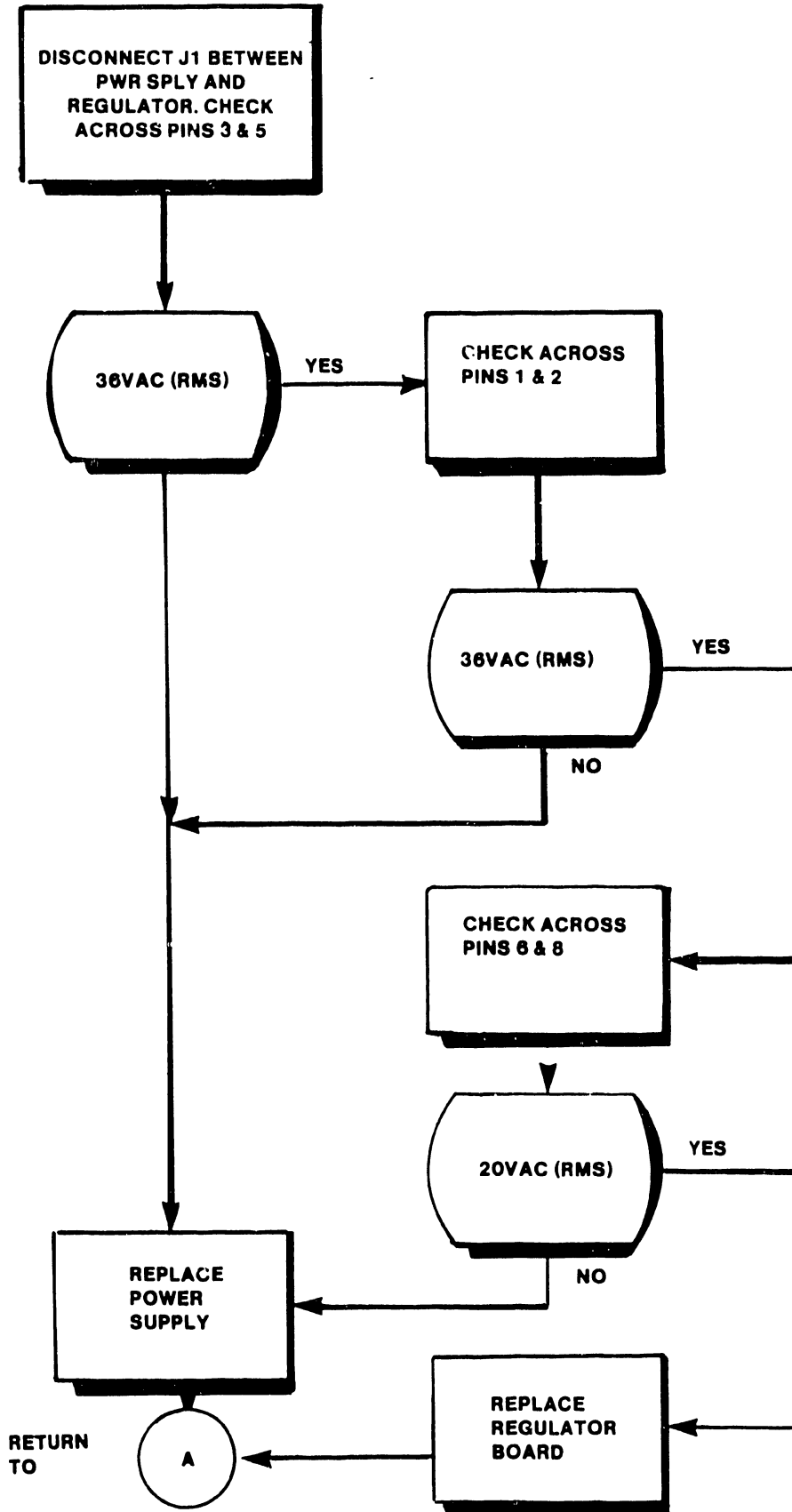
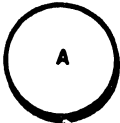

FIG. 2-6

TA-2 PRINTER FAILURE (1 OF 6)

DAISY WHEEL
NOT TURNING-
GO TO:



CARRIAGE
NOT MOVING-
GO TO:

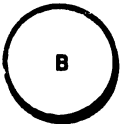

RIBBON NOT
ADVANCING-
GO TO:

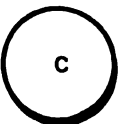

SH 3

PAPER NOT
LOADING-
GO TO:

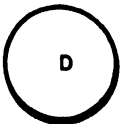

SH 3

HAMMER NOT ACTUATING-
GO TO:

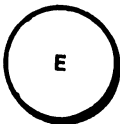

SH 5

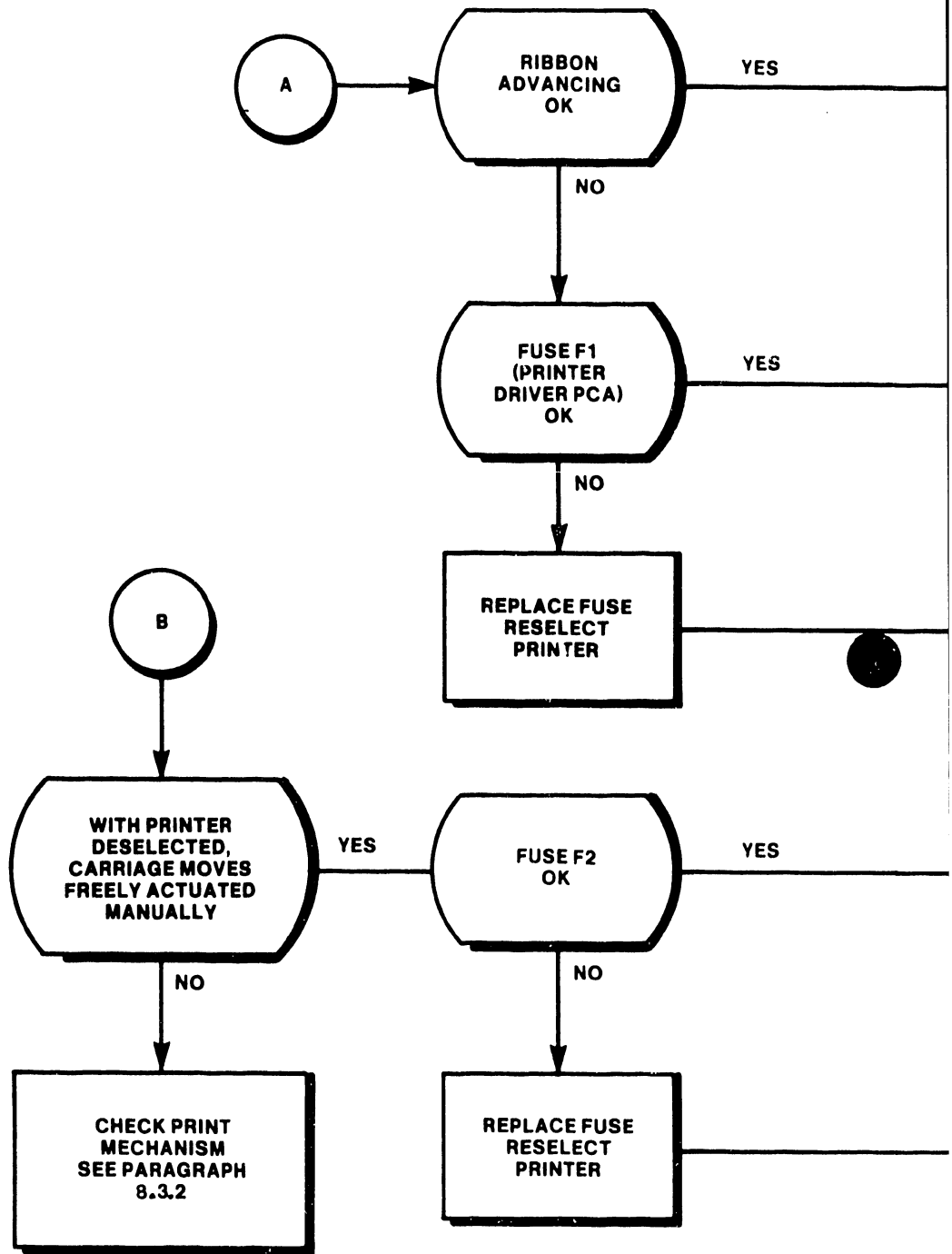

TA-2 (2 OF 6)

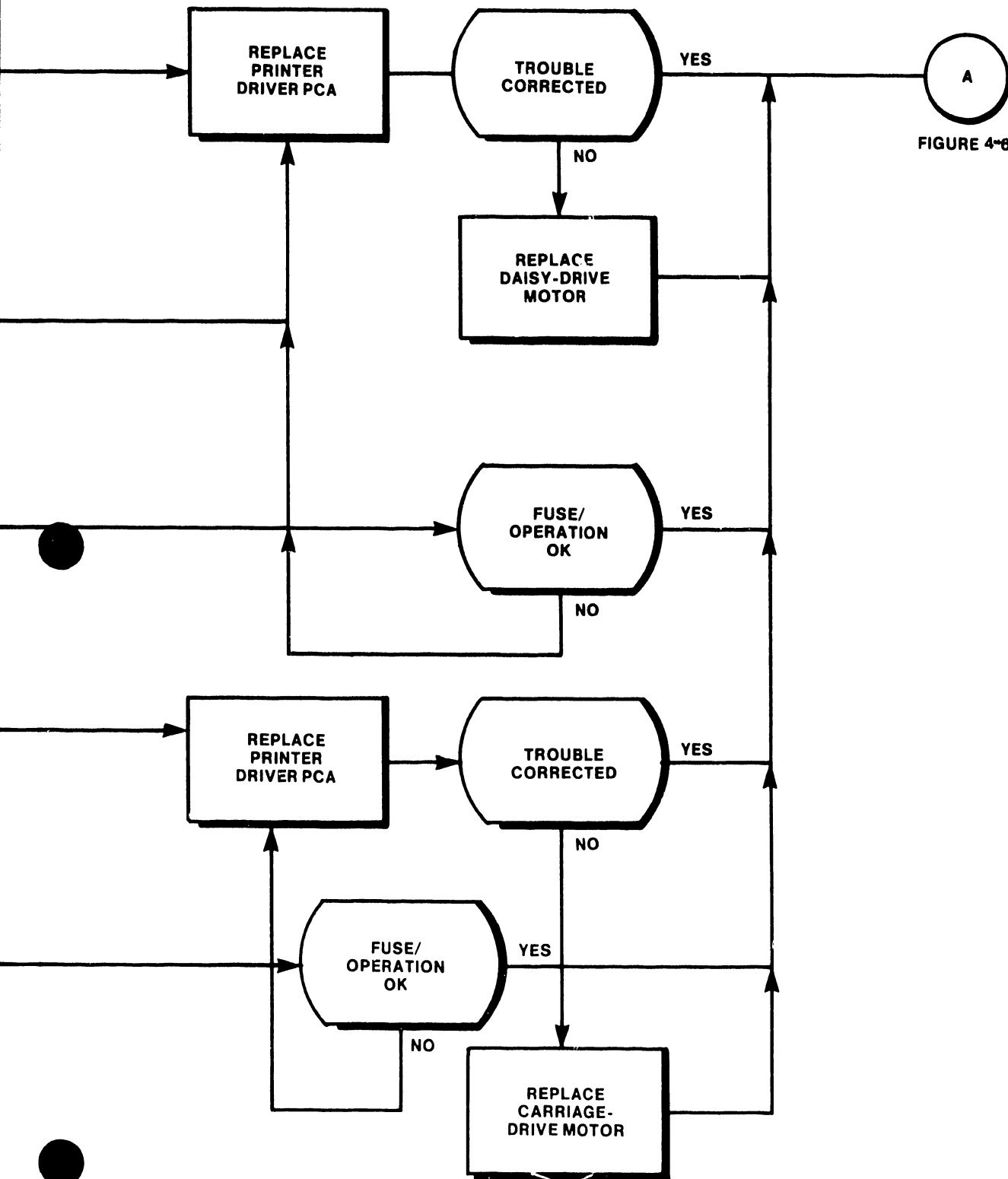
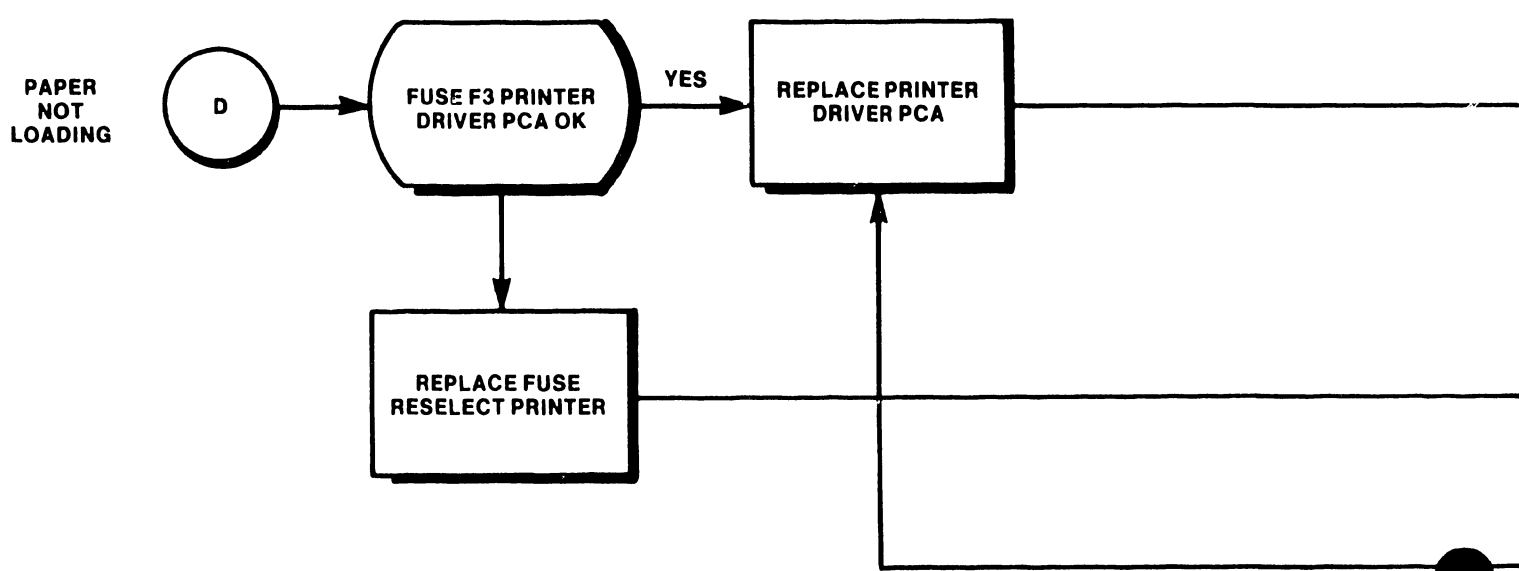
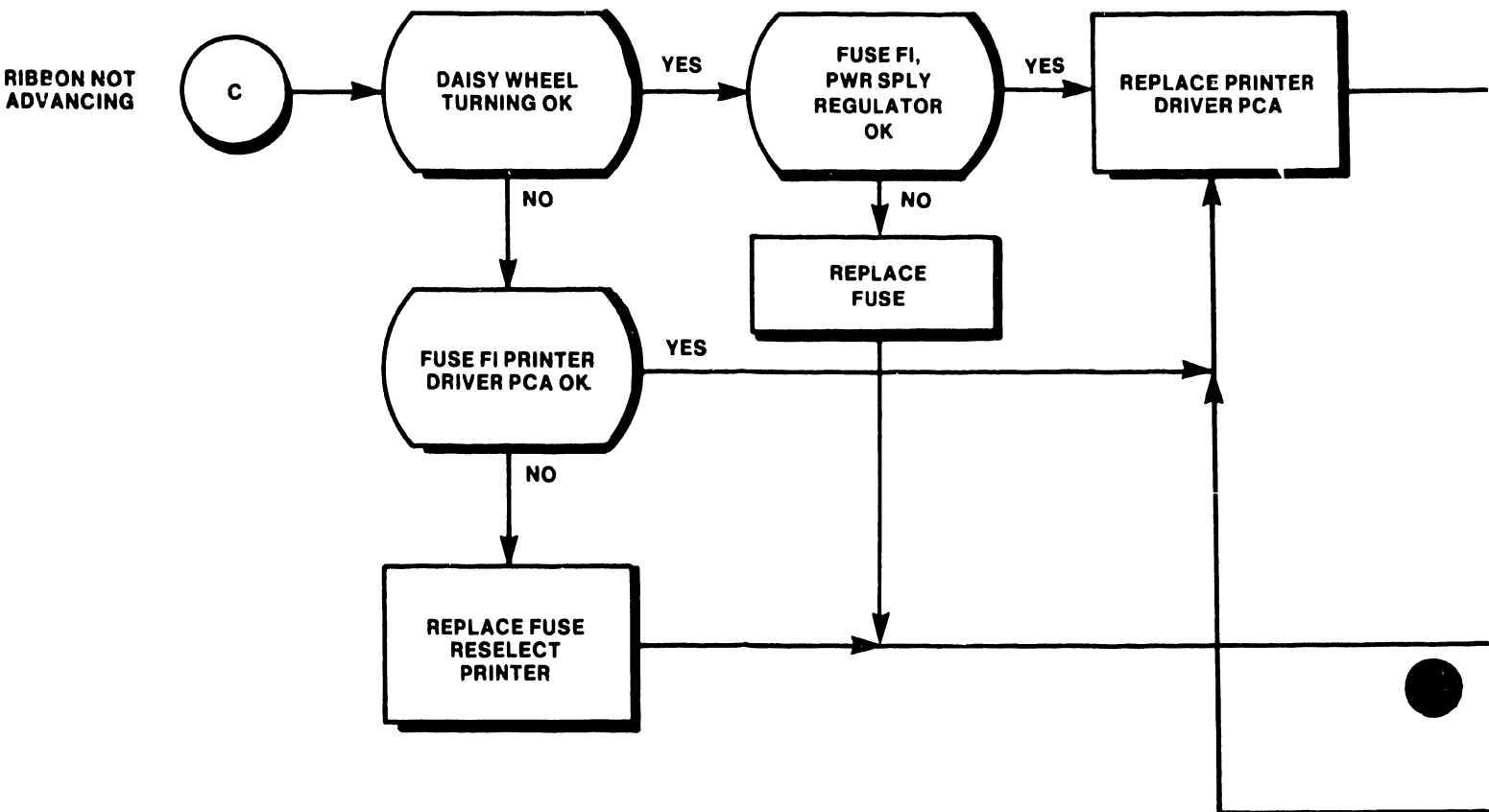
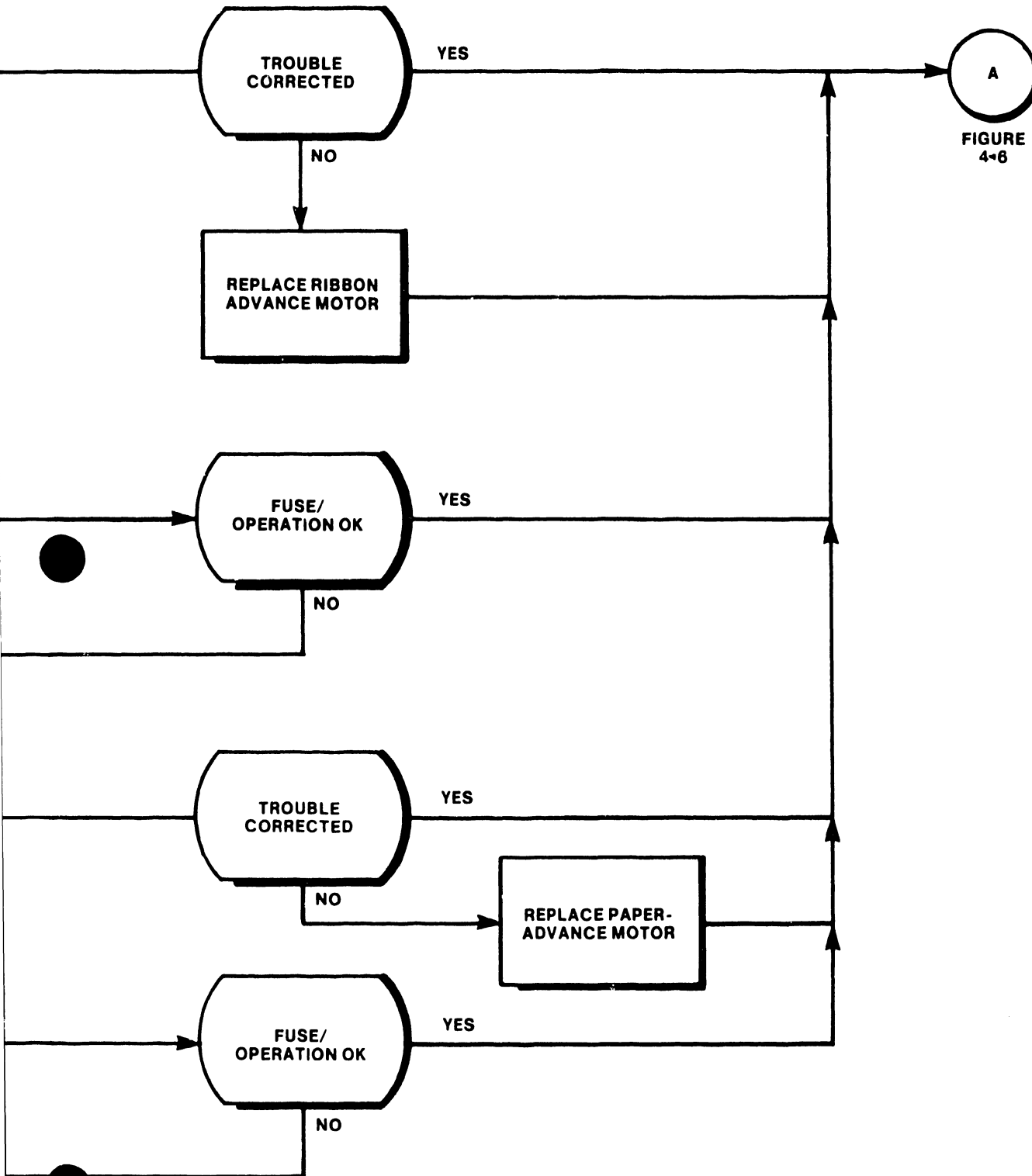

FIGURE 4-6

TA-2 (3 OF 6)



TA-2 (4 OF 6)



TA-2 (5 OF 6)

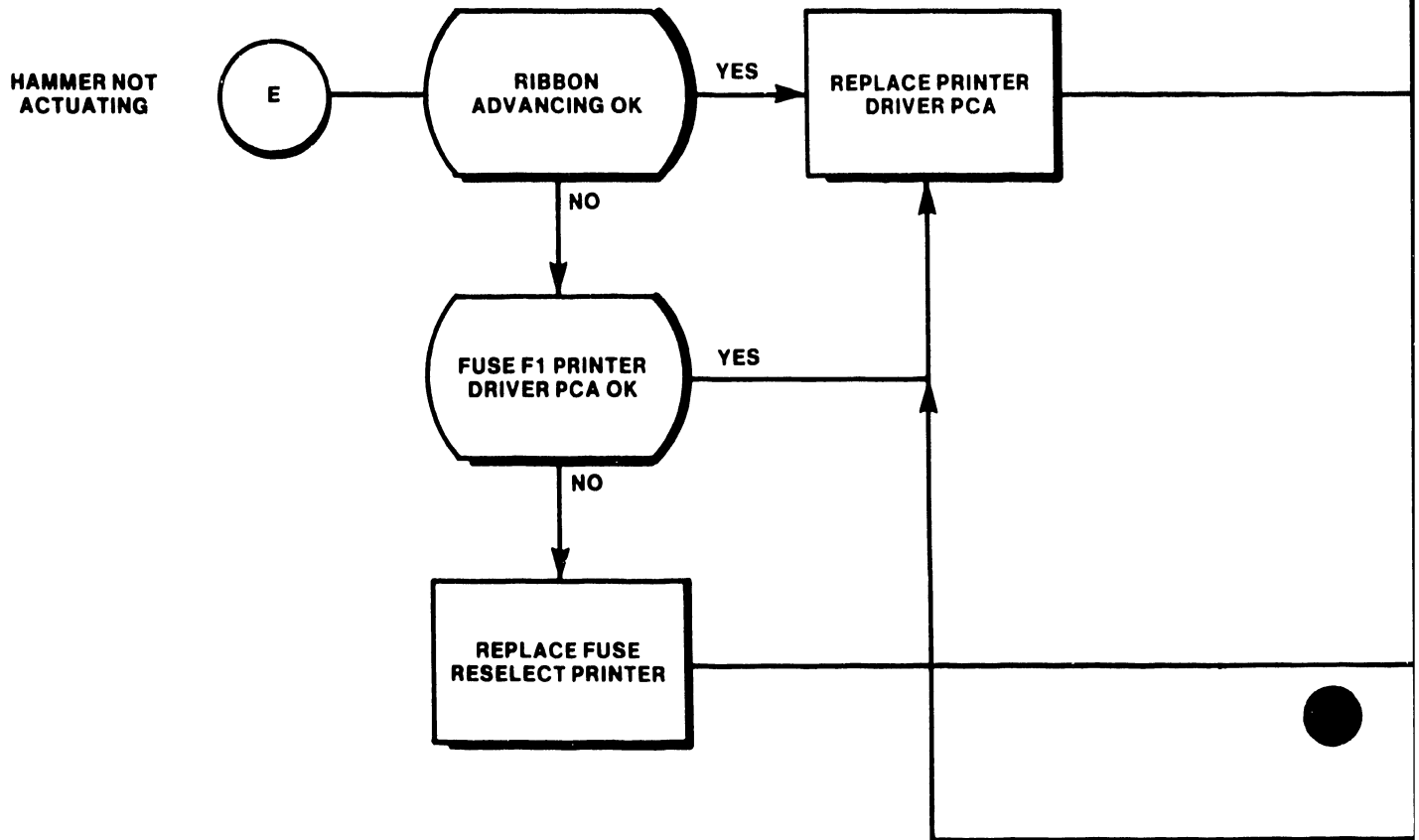

TA-2 (6 OF 6)

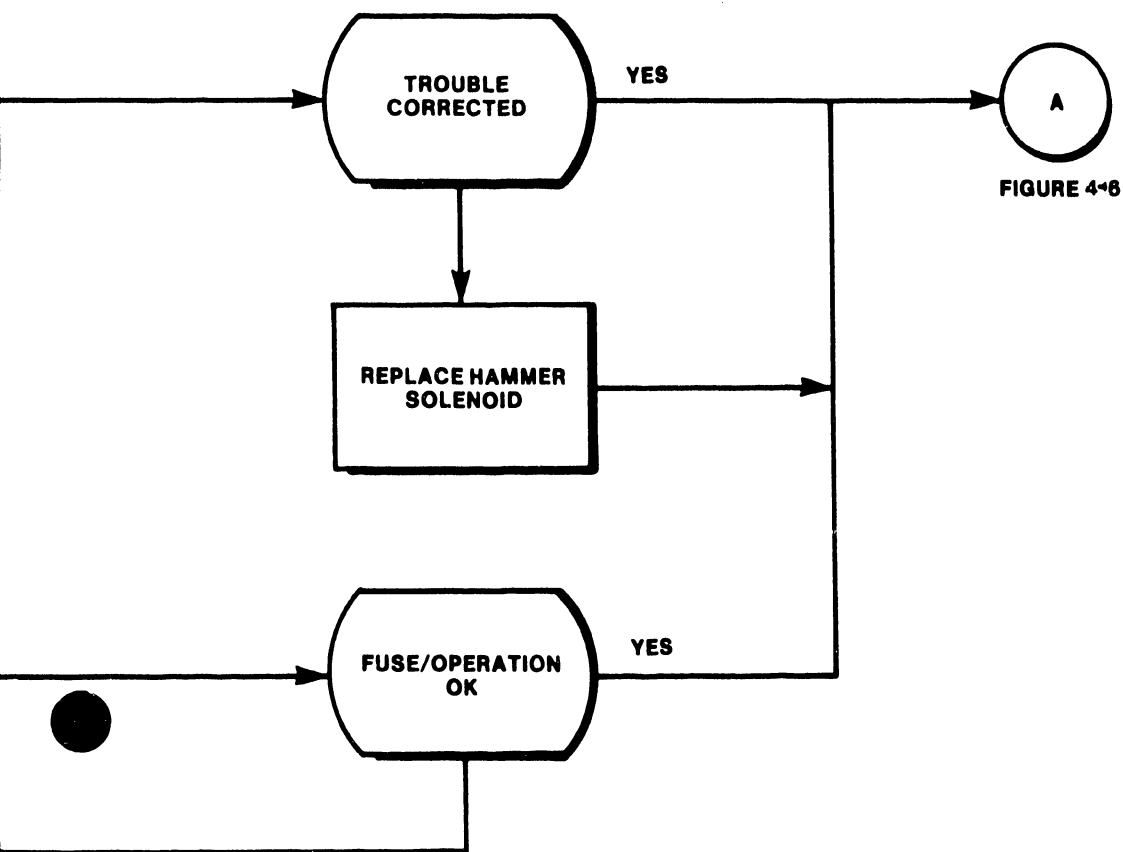

8.3.3 PRINT QUALITY TROUBLESHOOTING (continued)

<u>PROBLEM</u>	<u>EXPLANATIONS/ADJUSTMENT(S)</u>
2. Hard Right/Hard Left	<p>Hammer not centered on the petal; although the hammer when moved forward may appear to strike the center of the petal, the actual flight of the hammer may send it either right or left:</p> <p>Open head and loosen the three allen-head screws attaching the damper bracket to the motor. If the printout appears darker on the right, rotate top of damper bracket left, and vice versa.</p>
3. Light Tops/ Bottoms	<p>Hammer angle probably incorrect:</p> <p>Loosen two screws mounting the hammer housing and increase hammer tilt for light tops, and vice versa.</p> <p style="text-align: center;">OR</p> <p>Ribbon height is off; if either the top or the bottom of a character cuts off evenly, the problem is probably ribbon height: Adjust by forming ribbon height tab on the ribbon platform.</p> <p style="text-align: center;">OR</p> <p>Carriage height may be incorrect: If previous adjustments fail, either add or remove shims from between the carriage and the bearing housing. For light tops, add shims, and vice versa.</p>
4. Erratic Spacing	<p>Possibilities:</p> <ul style="list-style-type: none"> - Faulty daisy wheel - Incorrect wire rope tension - Daisy not damped properly: Check height of the daisy motor hub relative to the daisy damper; use .010" - .020" go/no go gage. For adjustment, either add or delete shims (see problem 3).

8.3.3 PRINT QUALITY TROUBLESHOOTING (continued)

<u>PROBLEM</u>	<u>EXPLANATIONS/ADJUSTMENT(S)</u>
5 Overall light	<p>Check Copy-Control Lever</p> <p>Ribbon may be binding due either to faulty cartridge or to the spike driver not having proper amount of spacers between the C-ring and the top spike.</p> <p>Opening of hammer solenoid gap to the high end of the tolerance range may improve performance;</p> <p style="text-align: center;">OR</p> <p>Reducing hammer-to-platen gap to the low end of the tolerance range.</p> <p>Driver card may be faulty; see TA-2.</p> <p>As last resort, replace print head assembly.</p>
6. Characters Up and Down	<p>Print wheel may be faulty</p> <p style="text-align: center;">OR</p> <p>Daisy motor hub may be non-concentric. Utilize self-test mode, and inspect the final line of that test (ErZ2m). If the baseline of these characters varies, the hub is not concentric. In this case, replace either the head or the daisy motor.</p>
7. Punctuation either Light or Missing	<p>Check and adjust solenoid gap</p> <p style="text-align: center;">OR</p> <p>Check and adjust platen-to-hammer and platen-to-daisy gaps.</p>

8.3.4 SINGLE-SHEET FEEDER TROUBLESHOOTING

Troubleshooting or corrective maintenance of the Single-Sheet Feeder at the customer or branch level is minimal inasmuch as failing units are to be replaced as complete assemblies. This limits corrective maintenance to the cleaning of the feeder tires, and checking for loose or worn parts including the drive belt and gear.

Adjustments consist of:

- Vertical positioning of the feeder - adjust the two feet (at the rear of the unit) so that the feeder aligns vertically with the printer console cabinet. Adjustment of the left foot (closest to the latch) is for front-to-back vertical alignment. The right foot is for left-to-right alignment to correct skew.
- Paper feed correction - adjust cartridge guides to make the paper feed straight into the platen on the printer. If the pusher plate does not touch both drive rollers at the same time, force into proper position. The pusher plate must touch both drive rollers at the same time to prevent the paper from skewing.

FAILURE ANALYSIS

<u>PROBLEM</u>	<u>POSSIBLE CAUSE</u>
Paper not feeding out of cartridge	<ol style="list-style-type: none"> 1. Paper not inserted properly in cartridge 2. LOAD/RUN knob not in RUN position 3. Too much paper in cartridge 4. Paper either too wet or too dry

8.3.4 SINGLE-SHEET FEEDER TROUBLESHOOTING (continued)

<u>PROBLEM</u>	<u>POSSIBLE CAUSE</u>
Paper not feeding straight, from cartridge	<ol style="list-style-type: none"> 1. Cartridge guide rails not equal 2. Pusher plate not putting equal pressure on drive rollers. Form pusher plate (force into position) for equal pressure. 3. Paper not inserted in cartridge properly
Paper not feeding into platen properly	<ol style="list-style-type: none"> 1. Feeder base not parallel to printer 2. Printer paper bail rollers not in correct position 3. Printer paper guide rollers not adjusted properly 4. Static causing paper to stick to feed tray 5. Printer assembly not positioned far enough left
Double feed - actual	<ol style="list-style-type: none"> 1. Spring off pusher plate 2. Paper not inserted in cartridge properly 3. Cartridge malformed concave, not allowing paper to press against drive rollers 4. Paper weight not 20 lb.

8.3.4 SINGLE-SHEET FEEDER TROUBLESHOOTING (continued)

<u>PROBLEM</u>	<u>POSSIBLE CAUSE</u>
Double feed - apparent	1. Paper skews out of cartridge, causing the trailing left edge of the paper to miss the out-of-paper sensor. This indicates to the system a false end-of-page; when the eject command is executed, paper does not get fed up enough for downward ejection into the stacker - instead, feeds back onto the feed tray while the next sheet feeds from the feeder on top of the first page.
Wavy line of print, or skew	1. Card guide out of adjustment, allowing top of paper to buckle at paper bail rollers.

APPENDIX

A

MNEMON-

IC

CODES

APPENDIX A

MNEMONIC CODE

1 2D	16MHz Clock
A0-A7	4 MHz Clock
	Addresses-Main Memory Select
A1-A8	Addresses-Main Memory Select
A2/A9	Addresses-Main Memory Select
A3/A10	Addresses-Main Memory Select
A4/A11	Addresses-Main Memory Select
A5/A12	Addresses-Main Memory Select
A6/A13	Addresses-Main Memory Select
AC0-7	
ALARM	Keyboard Alarm Signal
ARDY	Keyboard Read Signal
ASTB	Keyboard Strobe Signal
BA0-15	Buffered Address Signals 0-15 from Z80 CPU
BA0/CA	
BIORQ	Buffered Input/output request from the Z80 CPU
BM	Buffered Z80 CPU Machine Cycle One Signal
BMI	Buffered Z80 CPU Machine Cycle One Signal
BMREQ	Buffered Memory Request Signal from Z80 CPU
BRD	Buffered Z80 CPU Read Signal
BRFSH	Buffered Z80 Memory Refresh
BUSACK	Busy Acknowledge
BUSRQ	Bus Request
BWR	Buffered Z80 CPU Write

CAS	Column Address Strobe
CHAND	Change Daisy
CHANP	16MHz Clock
CHANR	Change Ribbon
CLICKER	Keyboard Clicker
CLK GATE	Dock Gate
CRC	Cyclic Redundancy Count
JRT RAM SEL	Select CRT RAM Memory
CSYNC	Cursor Syne
DO-D7	Data from Z80 Direct
DB0-7	Buffered Data
DIRECTION SEL	Select Direction of Disk Head Carriage
DISK DR	Disk Drive
DISK SELECT	Select Disk for Operation
DK CTRL	Disk Control
DOPT	Device Option
DRIVE SEL 0-1	Select Drive, either/or 1
ENABLE	Enable Chip
EX CLK	External Clock (diagnostic use)
FAULT	Maintenance Fault
H SYNC	Horizontal Synchronization
HAM	Hammer-Printer
HGR	Horizontal Graphic
HOME	Home Position
IE0-4	Interrupt Enable Signals
INDEX0-1	Disk Index Pulses (Disk 0 or 1)
INIT	Initialize
INT	Interrupt
INTEN	Intensity-(CRT)
INTENSITY	Intensity-(CRT)
KB CTRL	Keyboard Control
KB DATA	Keyboard Data
L LMT	Left Carriage Limit (Printer)
LD/SH	Load/Shift (Shift Register Control)
LDNSW	Line Down Switch Output Signal
LF DOWN	Line Feed Down (Printer)

LF UP	Line Feed Up (Printer)
LUPSW	Line Up Switch Output Signal
MBREQ	Memory Buss Request
MC	Master Clock
MONO-1	Motor On 0 or 1 (Disk Drive)
MOTOR ON 0-1	Motor On 0 or 1 (Disk Drive)
NMI	Non-maskable Interrupt
P CHOP 1	Paper Motor Control Chopped Signal 1
P CHOP 2	Paper Motor Control Chopped Signal 1
P HOLD	Paper Motor Hold (Brake) Signal
P LOAD	Paper Motor Load Signal
PG0-2	Paged Memory Select 0-2
PLSW	Paper Load Switch Signal
POR	Power On Reset
RAS	Row Address Strobe

**APPENDIX
B
RETROFIT FOR
SINGLE - SHEET
FEEDER**

APPENDIX B

RETROFIT FOR SINGLE-SHEET FEEDER

Wangwriter units manufactured before 1 April 1982 require a retrofit to accommodate the Single-Sheet Feeder; units manufactured after 1 April 1982 and before 15 January 1983 require a partial retrofit. The partial retrofit involves installation of a new-style card guide, EOP sensor shim, and screw and paper bail roller locator clips for feeder accommodation.

The Model 5503 retrofit requires use of a kit, UJ-1194 (see Figure 1), part No. 205/206-1194 (UJ-1194), consisting of:

NOMENCLATURE	PART NO.	NO.	
		REQ'D	REV
Door, Load Lever	449-0485	1	1
Slide	449-0574	1	0
Support	449-0576	1	0
Screw #6-3/8 Slf Tap, Blk	651-0061	2	
Door Hinge	458-2022	1	0
Locator Bushing, Platen	478-1049	1	1
Paper Bail Roller Assembly	279-0531	1	0
Roller, Paper Bail	465-1071	1	1
Hub, Paper Bail Roller	465-1057	2	2
Ring, Bail Roller	656-0108	1	
Shield, Side Frame	452-3577	1	2
Cap, Button	449-0492	1	1
Paper Guide	279-9000-21	1	1
Card Guide	452-4141	1	0

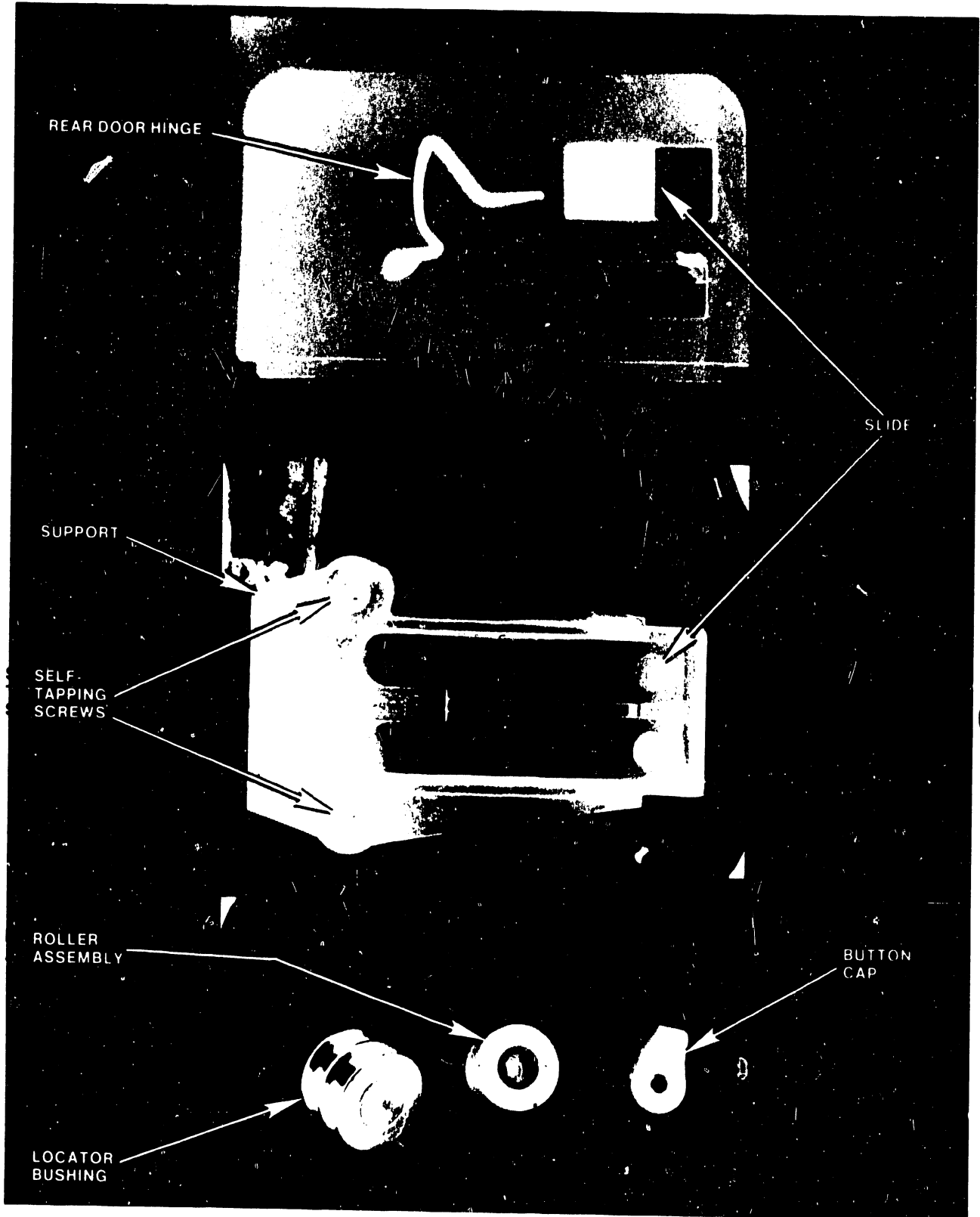

FIGURE 1 RETROFIT KIT PARTS

Retrofit Kit Parts (continued):

NOMENCLATURE	PART NO.	NO.	
		REQ'D	REV
Shim, End of Page Sensor .050	458-2058	1	A
Screw, End of Page Sensor	650-0045	1	
Paper Bail Roller Locator Clip	449-0682	4	A

The retrofit kit for 5504 models (UJ 205/206-1253) contains card guide, paper bail roller locator clip, and shim and screw.

Perform the following steps:

NOTE: Prior to installing the retrofit, or feeder if retrofit is not required, perform check 8b of this section. This should be done before any parts are changed.

1. Remove left side cabinet cover from the console.
 - a. Remove load lever door from the hinges. Remove only the rear hinge from the side cover.
 - b. Assemble new load lever door and new hinge to left side cover; assemble slide and slide support (if not already mounted) on the load lever door with the hardware provided).
2. Remove side frame shield from cabinet assembly (see Figure 2). Install new (reworked) side frame shield to cabinet.
3. Install paper bail roller assembly on printer assembly as follows (see Figure 3):
 - a. Remove clip from the left end of the paper bail roller shaft. Loosen set screw on load arm, and move load arm left until the bail roller shaft is free (do not allow bail arm spring to fall off).
 - b. Install new paper bail roller assembly on the shaft.
 - c. Slide bail arm back onto the bail shaft while sliding the load lever to the right and under the load switch; Tighten set screw.
 - d. Install holding clip over the shaft and against the bail arm.
4. Modify platen assembly as follows (see Figure 4):
 - a. Remove platen from the printer.

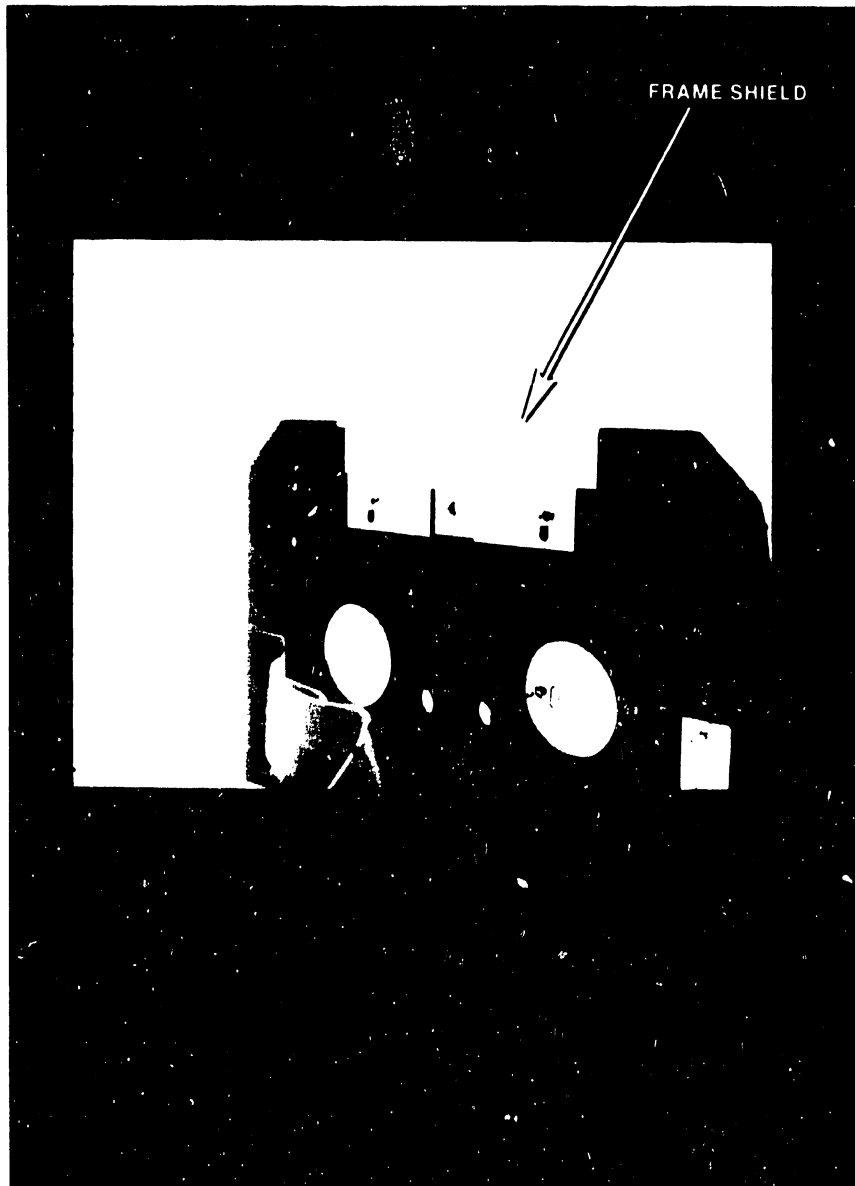

FIGURE 2 FRAME SHIELD REPLACEMENT

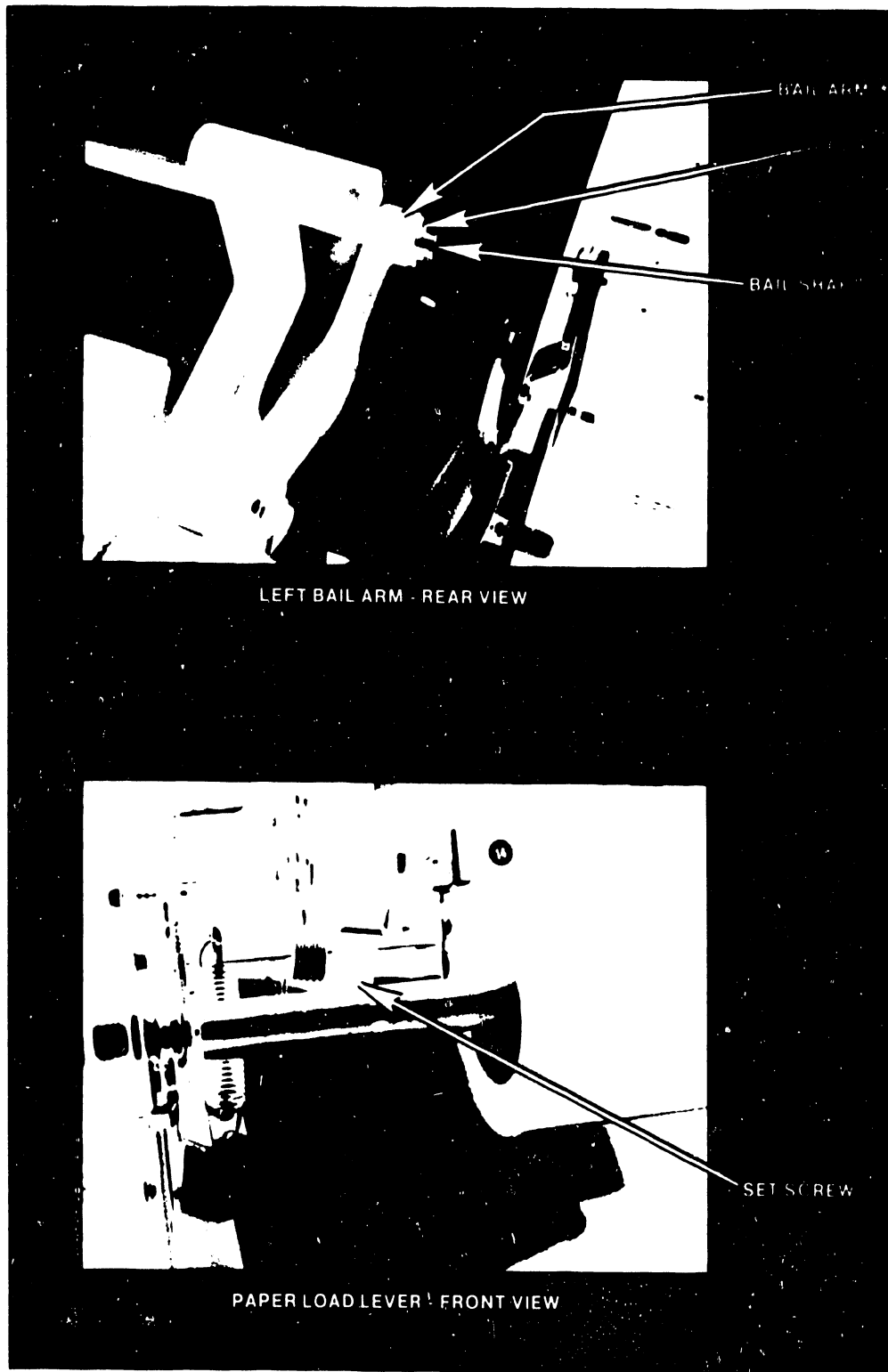

FIGURE 3 INSTALLATION OF ROLLER ASSEMBLY

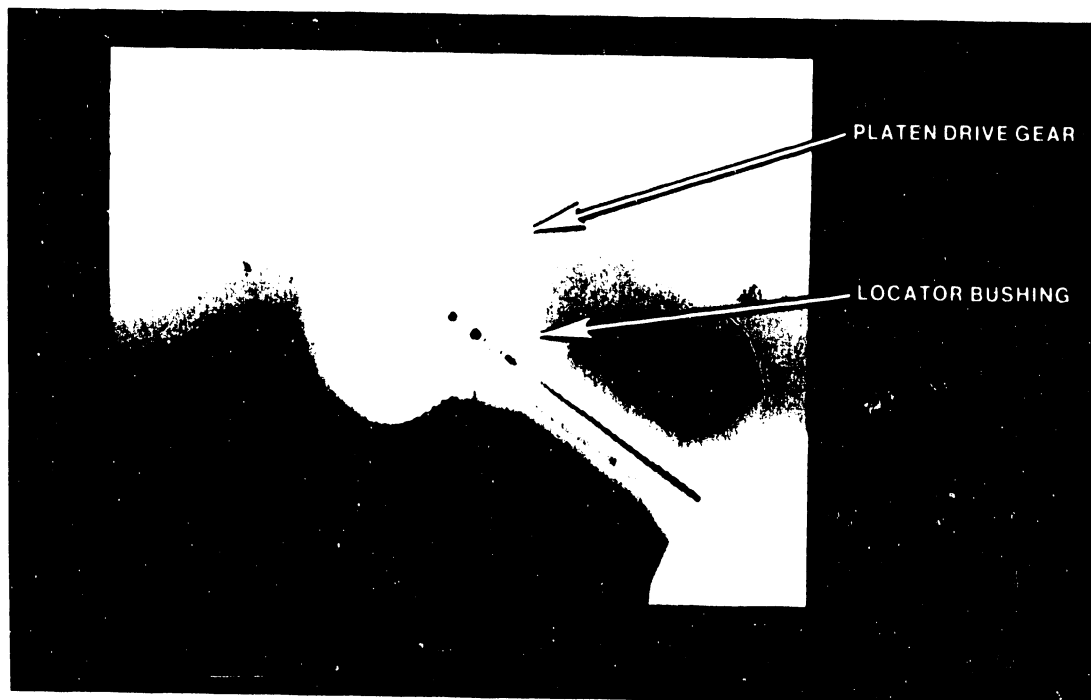

FIGURE 4 PLATEN ASSEMBLY MODIFICATION

RETROFIT PROCEDURE (continued)

- b. Remove clip from the left end of the platen. Loosen set screw and slide platen drive gear and locator bushing off the shaft.
 - c. Install the new double groove bushing onto the shaft with the thickest flange first (to the right).
 - d. Install drive gear and holding-clip on the shaft, and tighten the set screws. Do not reinstall platen until step 6c.
5. Replace Paper Tension Button, if present button is broken (see Figure 5):
- a. Remove paper guide.
 - b. Remove existing plastic button cap from the paper tension leaf spring.
 - c. Install new plastic button cap.
6. Install Out-of-Paper Shim
- a. Remove out-of-paper sensor screw, and replace with longer screw; insert .050 shim between sensor and bracket (remove paper tray first to facilitate access).
 - b. Install paper guide.
 - c. Replace platen on the printer.
7. Replace card guide with new style (wider) guide, and adjust. The top edge of the guide should be approximately 0.015 inch from the platen, and the left and right edges equidistant from the platen. Adjust the guide as high as possible without it hitting the rollers when the carriage moves.
8. Check printer adjustment.
- a. Verify that all six paper guide pressure rollers are against the platen with the paper release lever in operating (rear) position. If necessary, bend the holding tabs (see Figure 6) at the ends of the roller shafts for proper adjustment. Pressure between platen and rear (entrance) pressure rollers should be sufficient to prevent the forcing of a sheet of 20-pound bond paper between rollers and platen. Check that the pressure is the same for the middle and both end rollers by inserting and pulling a narrow piece of paper between the individual rollers and the platen.

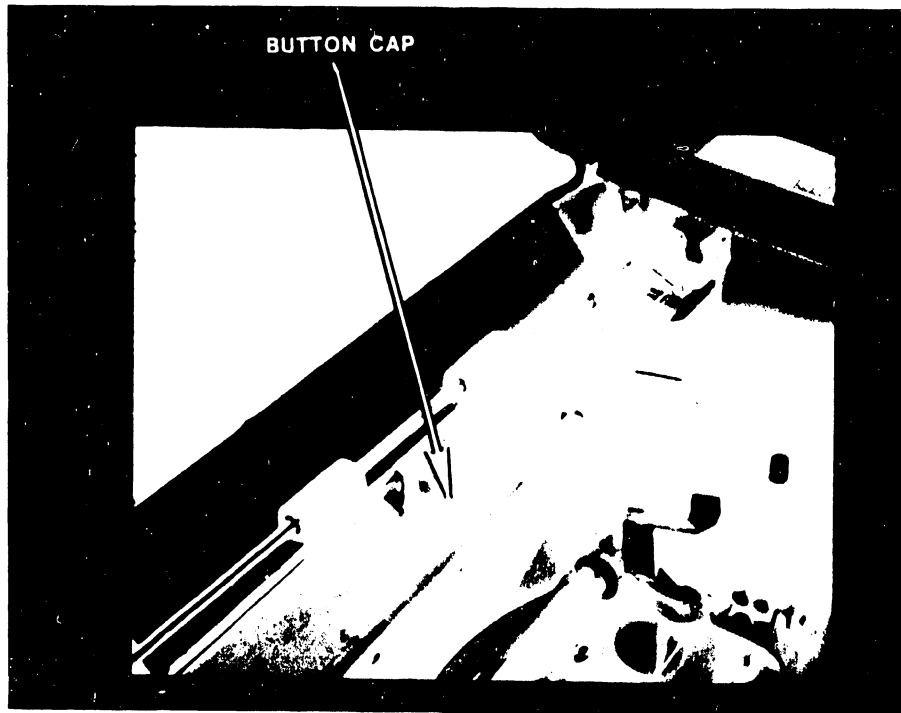

FIGURE 5 PAPER TENSION BUTTON REPLACEMENT

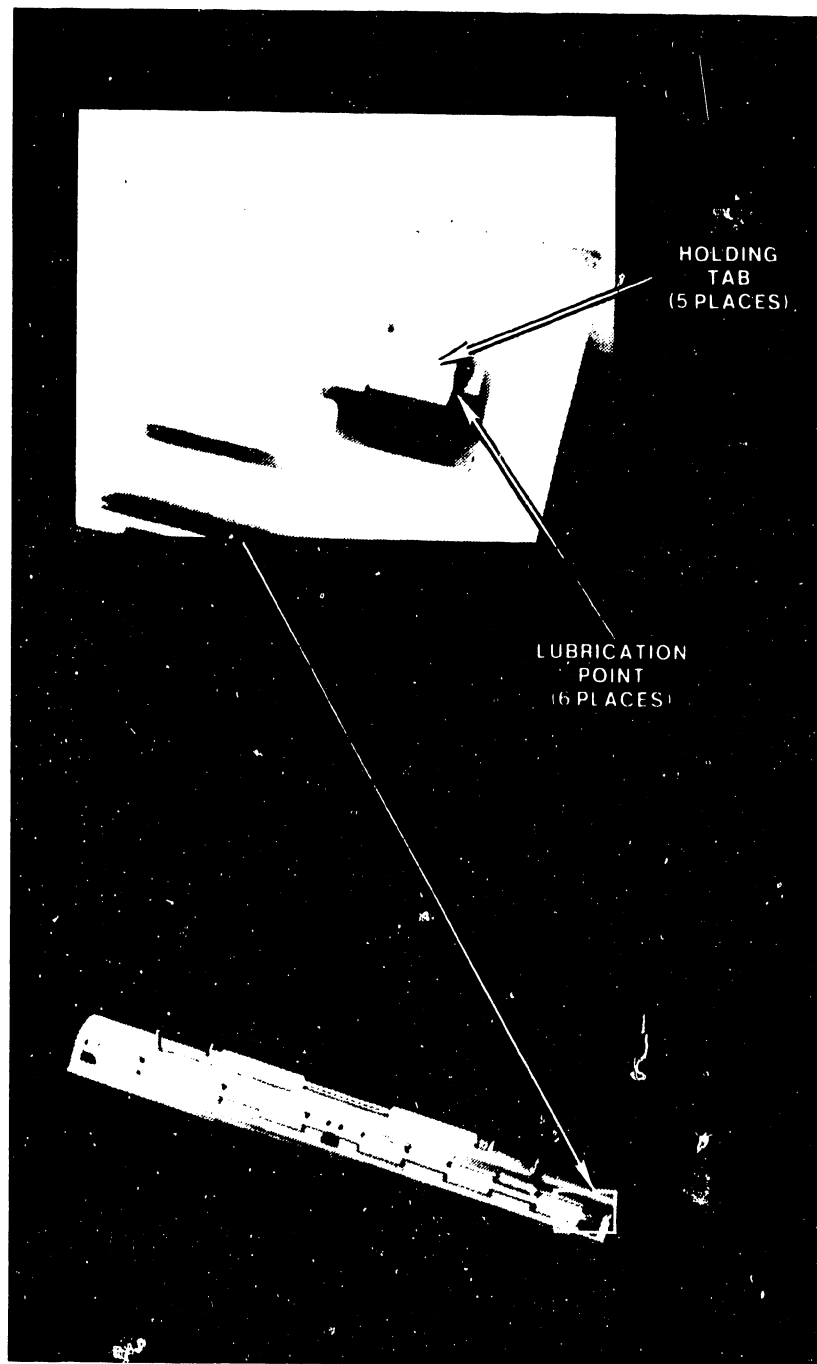

FIGURE 6 PRESSURE ROLLER ADJUSTMENT

RETROFIT PROCEDURE (continued)

Rollers should stay assembled to the paper guide during normal handling, not binding on the paper guide when installed. Lay paper guide, inverted, on a flat surface to verify that the paper guide is not twisted. If necessary, twist paper guide slightly to make it even. Place lubricant at the holding tabs. The upgrade kit includes a paper guide which may be required if the original is worn (roller shaft) or bent.

- b. Insert a sheet of paper into the platen feed area, with the paper left edge 1/16 inch from the left edge of the paper tray. Pull load arm to load the paper. Create and print a test document comprising a line of upper-case T's, 80 columns wide, at the top of the page. Use a left margin of 005 in the printer menu. Measure from the top of sheet to the bottom of the character at column 1; repeat for column 80. Difference between measurements should not exceed 0.050 inch. To make a quick check, fold printed page so that column 80 lies over column 1 with the top edge of the paper even. Hold the folded page up to the light to see if columns 1 and 80 are at the same distance from the top.

NOTE

Failure of the paper to feed, paper skew, or a creasing of the paper, indicates improper roller adjustment on the paper guide. Adjust entrance rollers as necessary to correct skew. Any paper skew must be corrected prior to installation of the feeder.

- c. Check printer positioning: (Install feeder per following paragraph, FEEDER INSTALLATION, page 14 - steps 1 through 3.) When the feeder is installed with the latch engaged on the platen flange, the retainer on the right side of the feeder should easily fit into the space between the printer cover lid and the cabinet frame at the printer cover hinge.

RETROFIT PROCEDURE (continued)

If the printer requires repositioning: Loosen nuts securing the printer shock mounts, and move the printer. Should the paper feed tray limit printer movement toward left cabinet frame, reposition paper tray mounting bracket to the right (as viewed from front of unit). Ensure that tray remains perpendicular and parallel to the platen.

- d. Position the four paper bail rollers with the two left rollers together with the left edge of the left roller 2.65 inches from the left edge of the platen (see Figure 7). Place other two rollers together with the left edge of the left roller 5.90 inches from the left edge of the platen (A reference template is included with the feeder for this adjustment). Install the four bail roller locator clips on each side of the rollers.

Should either the right or left paper edge fail to go under the paper bail during use of the feeder, move the respective outside roller up to an inch (total movement) closer to the end of the paper bail shaft.

NOTE

If the card guide is too low, the paper may not go under the rollers. If too high, the card guide will hit the bail rollers. The left and right sides of the card guide should be equidistant from the platen. The top edge of the guide should be approximately 0.015 inch from the platen.

- e. Check that the out-of-paper sensor does not catch the paper as the paper feeds from the feeder. If necessary, press down the bracket attaching the sensor.
- f. Reinstall cabinet sides.

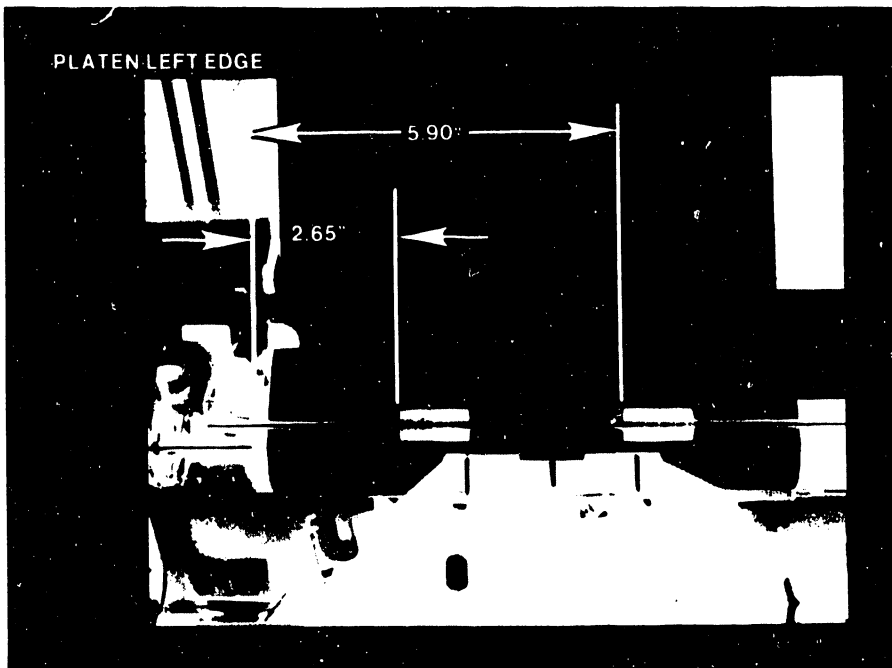

FIGURE 7 ROLLER ASSEMBLY PLACEMENT

SPECIFICATIONS

DIMENSIONS

	<u>WIDTH</u>	<u>DEPTH</u>	<u>HEIGHT</u>
Inches	16.75	7	17
Centimeters	42.6	17.8	43.2

WEIGHT

	<u>BASIC UNIT</u>	<u>CARTRIDGE</u>
Pounds	5.5	1.0
Kilograms	2.5	0.45

RECOMMENDED PAPER

For optimum efficiency of the feeder, use plain bond paper with 25% or less rag content of the following weight:

20 lb (75 g/M²)

Useable, but not recommended:

16 lb (60 g/M²)

24 lb (90 g/M²)

SPECIFICATIONS (continued)

PAPER CARTRIDGE SIZES

Six cartridge sizes are available for the following paper widths (measurement units are inches/centimeters); tolerances for all measurements are .020 inches/.05 centimeters:

<u>WANG PART NO.</u>	<u>WIDTH</u> <u>INCH/CM</u>	<u>LENGTH</u>	
		<u>MIN</u> <u>INCH/CM</u>	<u>MAX</u> <u>INCH/CM</u>
449-0599	7.25/18.42	10.5/26.67	14/35.56
449-0598	7.5/10.05	10.5/16.67	14/35.56
449-0600	8/20.32	10.5/26.67	14/35.56
449-0337	8.25/20.96	10.5/26.67	14/35.56
449-0591*	8.27/21 (DIN A4)	10.5/26.67	14/35.56
449-0338**	8.5/21.59	10.5/26.67	14/35.56

*Designates the standard size cartridge for international use.

**Designates the standard size cartridge for U.S. use.

SHIPPING PACKAGE (See BOM 290-0055)

The shipping package contains both the feeder and the standard paper cartridge. A box label identifies cartridge size. Outside dimensions of the shipping package are:

	<u>LENGTH</u>	<u>WIDTH</u>	<u>DEPTH</u>	<u>SET-UP VOLUME</u>
Inches	19.75	9.25	19.44	2.03 cu ft
CM	50.1	23.5	49.3	0.058 cu meter

RECOMMENDED ENVIRONMENT

Extreme combinations of temperature and humidity do not affect the feeder, as such; however, various conditions may affect the paper thus impairing feeder reliability.

SPECIFICATIONS - RECOMMENDED ENVIRONMENT (continued)

Temperature

The ambient temperature range should be within the limits of 15°C to 28°C (60°F to 90°F). A nominal temperature of 21°C (70°F) is optimum.

Humidity

A range of 35% to 65% relative humidity is optimum.

PERFORMANCE RELIABILITY/LIMITATIONS

Predictions as to the life of the feeder, frequency of maintenance, and performance reliability, presume a duty cycle of 10% (2.4 hours) based upon a 24-hour day. This coincides with the expected duty cycle of the Wangwriter printer.

If recommended paper is used and environmental conditions are within the specified limits, the feeder should on the average have no more than one misfeed per 250 (plus) sheets. This occurrence frequency lies within the normal probability range of failures caused by minor paper irregularities, etc.

The feeder will not operate reliably with:

1. Other than listed weights and sizes.
2. Multi-part forms.
3. Embossed paper.
4. Damaged paper (folded, curled, roughed edges, etc.).
5. Other than bonded paper.
6. Improperly stored paper.
7. Paper left in the cartridge in the feeder for a long period of time.
8. Excessive paper in the cartridge.

APPENDIX

C

INSTALLATION OF SECOND DISK DRIVE

APPENDIX C

INSTALLATION OF SECOND DISK DRIVE

The installation of a second disk drive upgrades Wangwriter Model 5503A to a Model 5503D dual-disk system (see Upgrade Job 1163). The hardware changes (see Figure 1) consist of:

- Installation of the second disk drive
- Connection of a second power cable between the power supply regulator board and the new disk drive
- Changing of the signal cable from previous connection between J3 (CPU board) and old disk drive, to new connection between J3 and new disk drive (system disk position).
- Installation of a new signal cable between J2 (CPU board) and the old disk drive (now archive disk position).

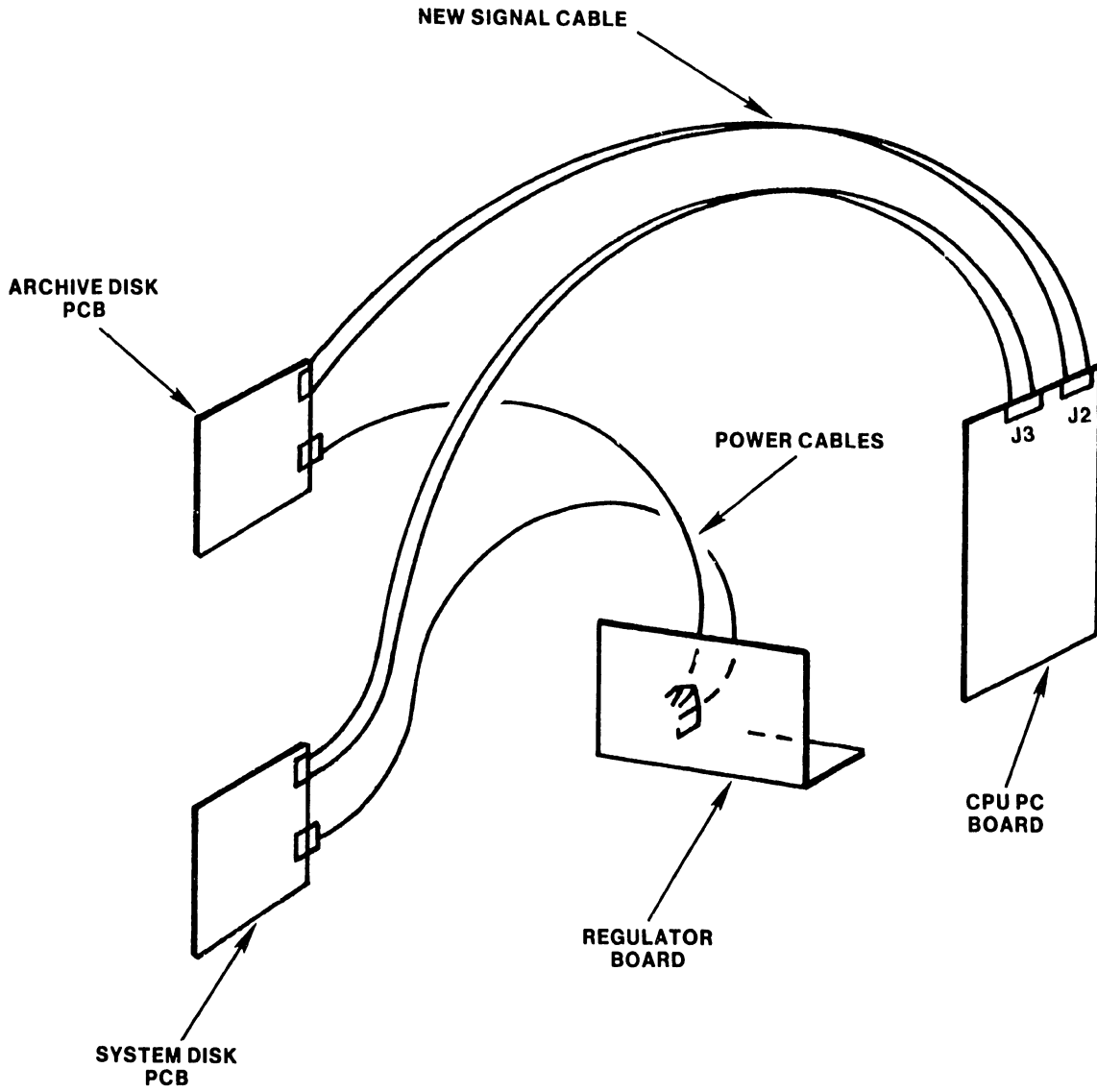

FIGURE 1 DUAL-DISK CONVERSION POWER/SIGNAL CONNECTIONS

Parts Required (see Figure 2):

<u>PART NO.</u>	<u>DESCRIPTION</u>
725-4022	Disk Drive, 5 1/4 DSDD
220-1472	Disk power cable assembly
220-3131	Disk signal cable assembly
650-3132	Screw, Machine, Truss Hd, 6-32 x 3/8
449-0515	Side panel, two-disk
615-1073	Label, Model 5503D
653-3001	Washer, Lock, Internal Tooth

Installation Instructions:

- a. Remove ac power cable from both the wall receptacle and the power supply.
- b. Remove printer module left cover.
- c. Disconnect signal and power cables of the disk drive (See Figure 3).
- d. Remove disk drive and mounting plate: Loosen hex head screws, and slide mounting plate to the left and away (out) from the frame.
- e. Install second disk drive on the mounting plate below the present drive; use four screws provided in the kit. Leave screws slightly loose.
- f. Align disk drives (see Figure 4): Place straight-edge against the front of the two drives, and move new drive to align the front of the two drives. (This step compensates for slightly differing distances, on the MPI and Tandon drives, between the mounting-screw holes and the front surface of the respective drives.) When the drives are aligned, tighten screws.
- g. Close disk drive doors, and install disk drives and mounting plate in the cabinet; ensure that front of each drive is seated in the cutouts of the plate at the front of the cabinet. If the drives are positioned properly, the doors should open and close without catching on the front plate; the activity LED should fit in the hole provided.

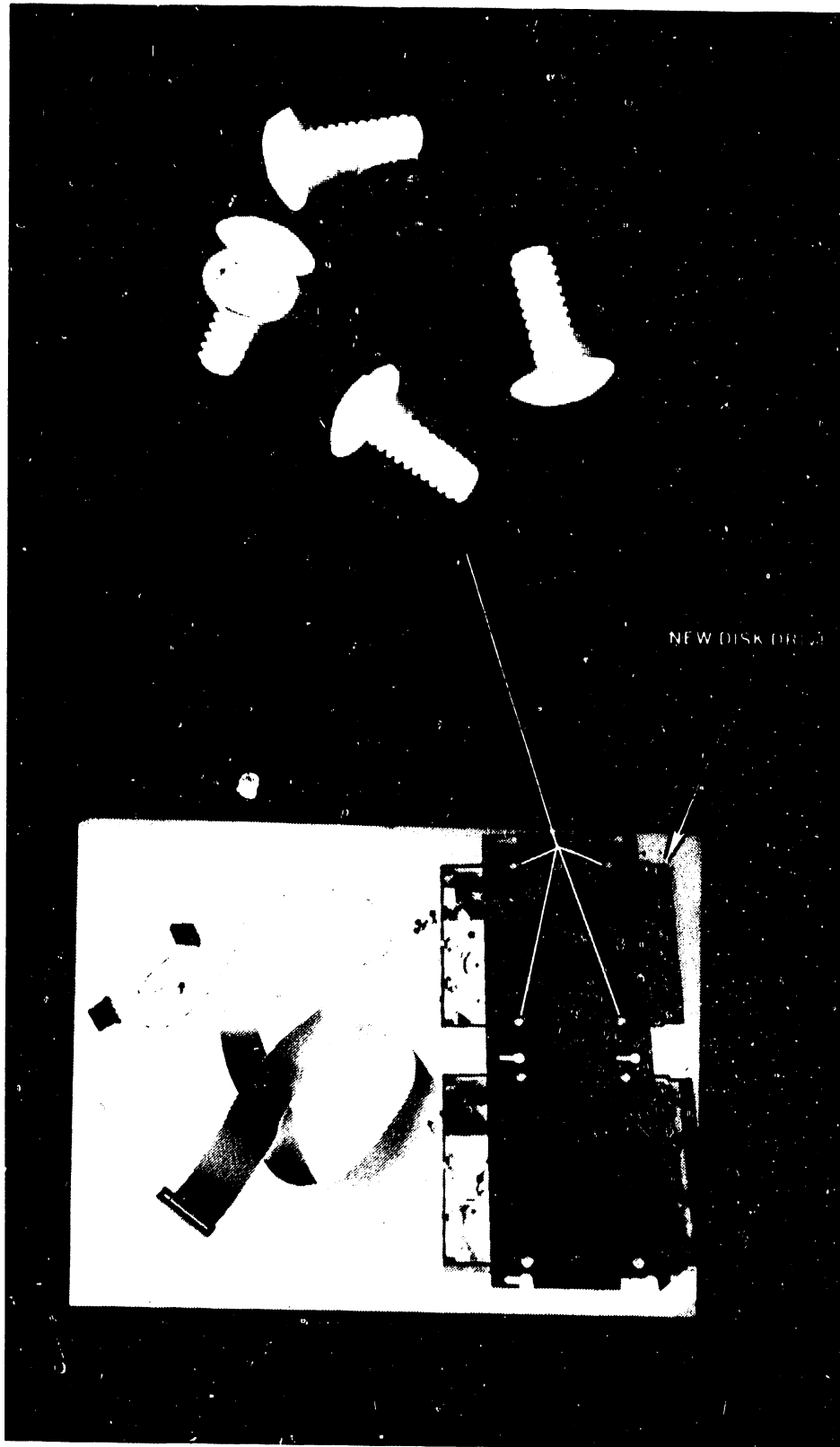

FIGURE 2 UPGRADE - JOB PARTS

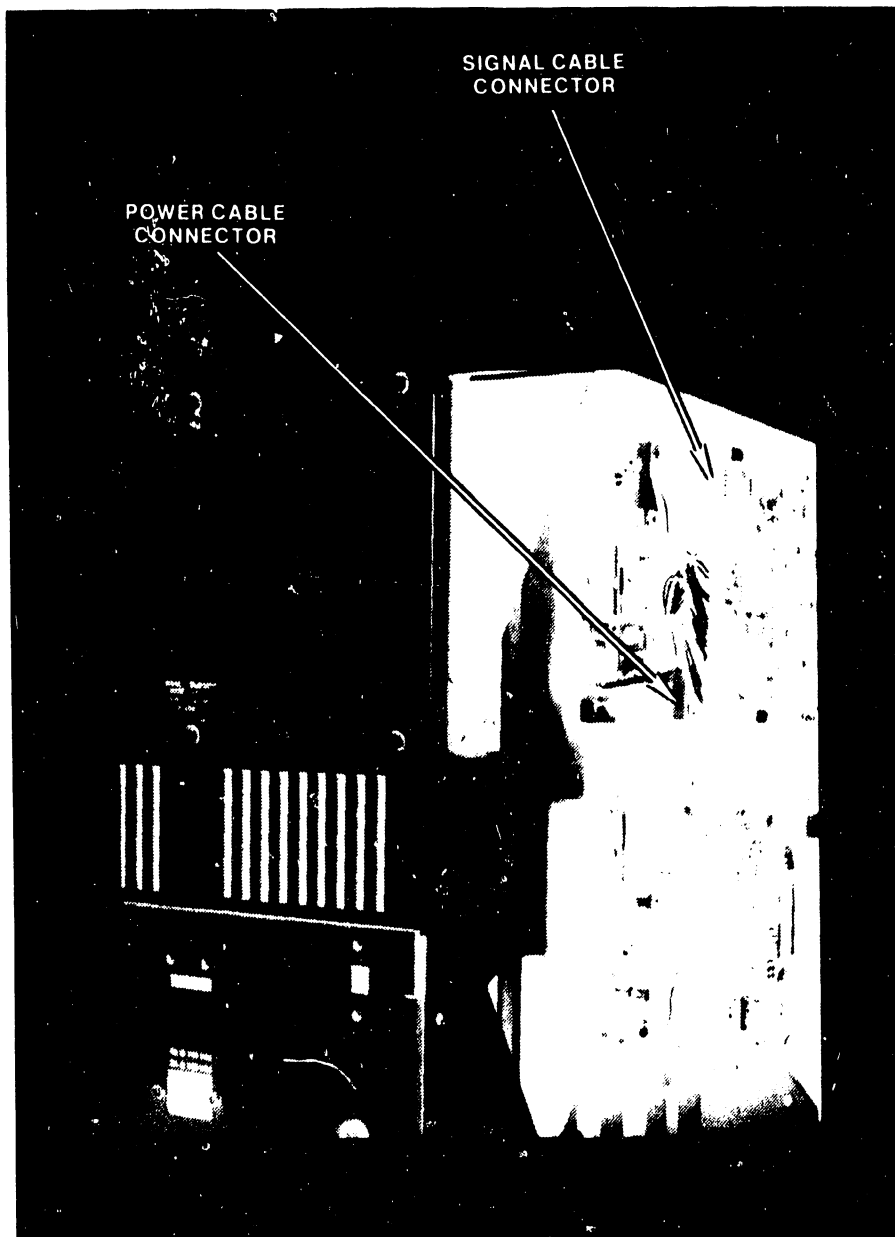

FIGURE 3 DISK DRIVE POWER AND SIGNAL CABLE CONNECTORS

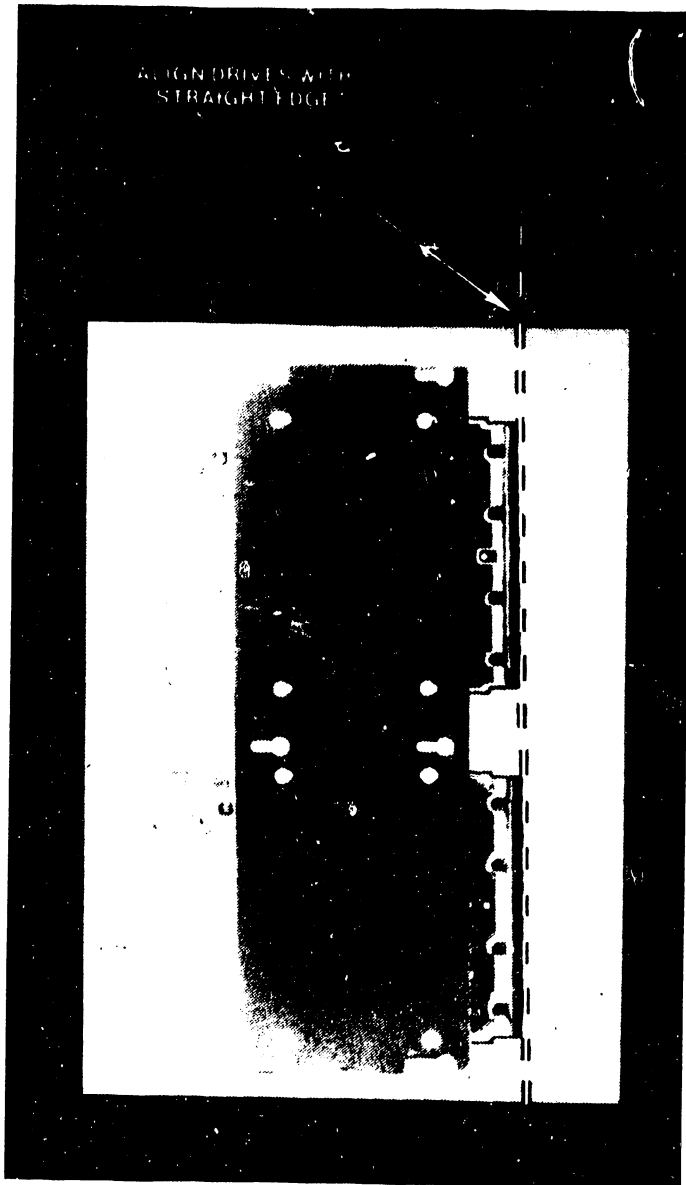

FIGURE 4 DISK DRIVE POSITION ALIGNMENT

Disk Drive Installation Instructions (continued)

- h. Remove power supply:
1. Remove right side cover from the printer cabinet.
 2. Remove four screws at the rear sides of the cabinet (see Figure 5) holding the power supply chassis in place.
 3. Disconnect the two power cables from the printer and CPU PC boards (see Figure 6).
 4. Slide power supply out of the cabinet; guide disk power cable and PC board power cables through the sides of the cabinet, carefully.

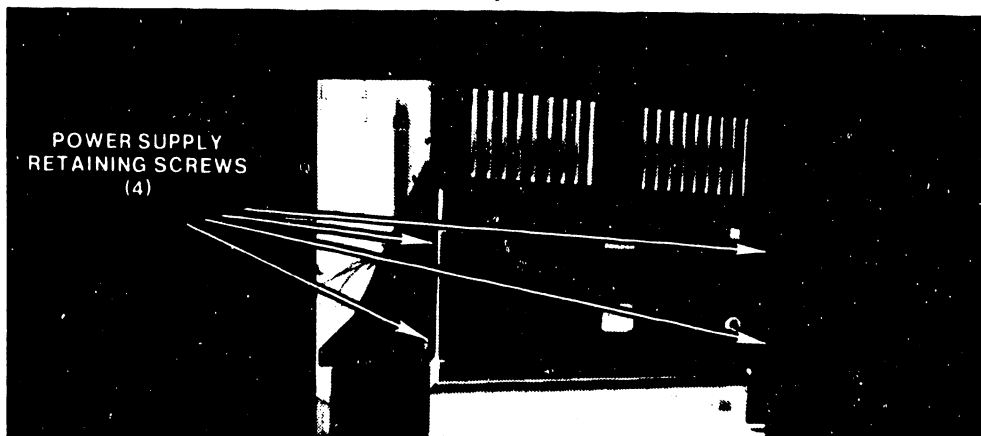

FIGURE 5 POWER SUPPLY REMOVAL

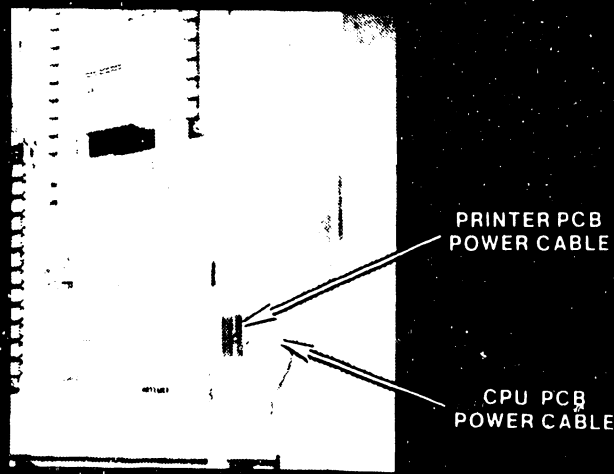

FIGURE 6 POWER CABLES - PRINTER AND CPU BOARDS

- i. Reinstall power supply and power cables:
 1. On the power supply regulator board, install new disk power cable in the connector provided (see Figure 7) adjacent to the existing disk power cable connector.
 2. Route free end of the power cable along the path of the first power cable; tie-wrap to the existing cables.
 3. Reinstall power supply and route power cables through the sides of the cabinet.
 4. Reconnect power cables to the proper PC boards; connect disk drive power cables.

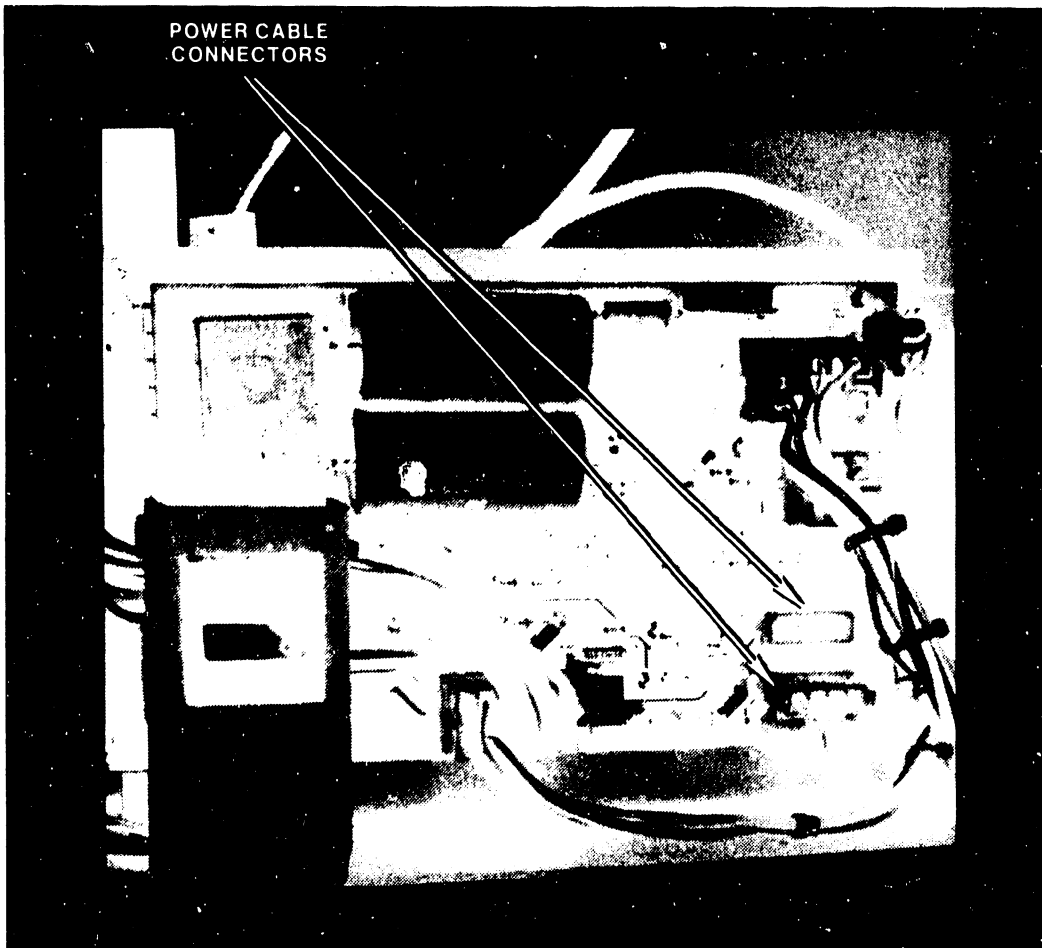
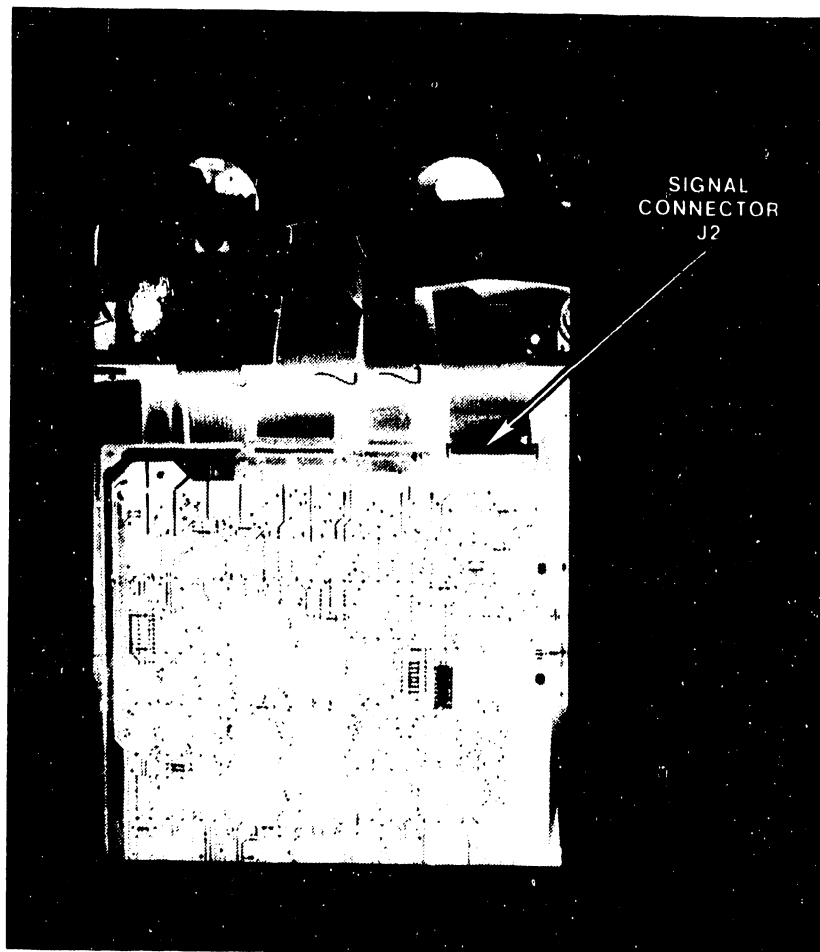

FIGURE 7 REGULATOR BOARD DISK POWER CONNECTORS

Disk Drive Installation Instructions (continued)

- j. Install new disk signal cable;
 1. Note that connectors match the present cable, and that the red line on the cable is at the top.
 2. Remove printer top cover and paper feed tray, and insert cable behind the printer and through the same holes as used by the existing cable. (Ensure that cable is not bent or jammed between the printer and the rear panel. If necessary, lift rear of the printer from the shock mounts, slip cable down, and reinsert printer into the shock mounts; use care to avoid pinching the cable between the printer and the cabinet.)
- k. Insert new signal cable on the rear connector (see Figure 3) of the top disk drive (archive disk drive), and insert other end in the CPU board connector J2 on the right side of the board (see Figure 8).

**FIGURE 8 CPU PC BOARD SIGNAL CONNECTOR FOR ARCHIVE DISK**

- m. Insert original disk signal cable on the rear of the bottom drive.
- n. Remove printer driver PC board; on the 210-7777 CPU PC board, set option switch number 4 to ON position. Reinstall printer driver PC board.
- p. Check jumper block on the disk drive for proper configuration (same on single and dual disk systems) Disconnect pins as shown in the following sketch:

MPI DRIVE (see Figure 9) TANDON DRIVE (see Figure 10)

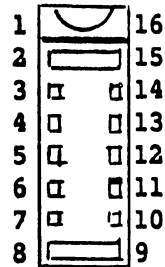
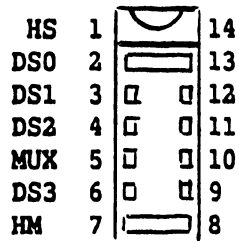

- q. Verify that VCO adjustment is correct (Model 5503 only):
 1. Load system Diagnostics disk per standard procedure (see Chapter 8, Wangwriter Maintenance Manual). Select VCO adjustment from main menu.
 2. On CPU PC board, adjust VCO pot (lower left edge of board) ccw until the test display indicates VCO failure. Return pot adjustment to the point at which the test display indicates satisfactory status. Note position of pot adjustment.
 3. Repeat step 2, but make adjustment clockwise, to determine cw limit of adjustment.
 4. Set pot adjustment at a point midway between the ccw and cw adjustment limits.
- r. Run Diagnostic disk test on the disk drives separately, then select both disk drives. If a CRT display distortion or disappearance occurs when two disks are tested, either an adjustment of the +12V supply or replacement of the power supply regulator may be required.

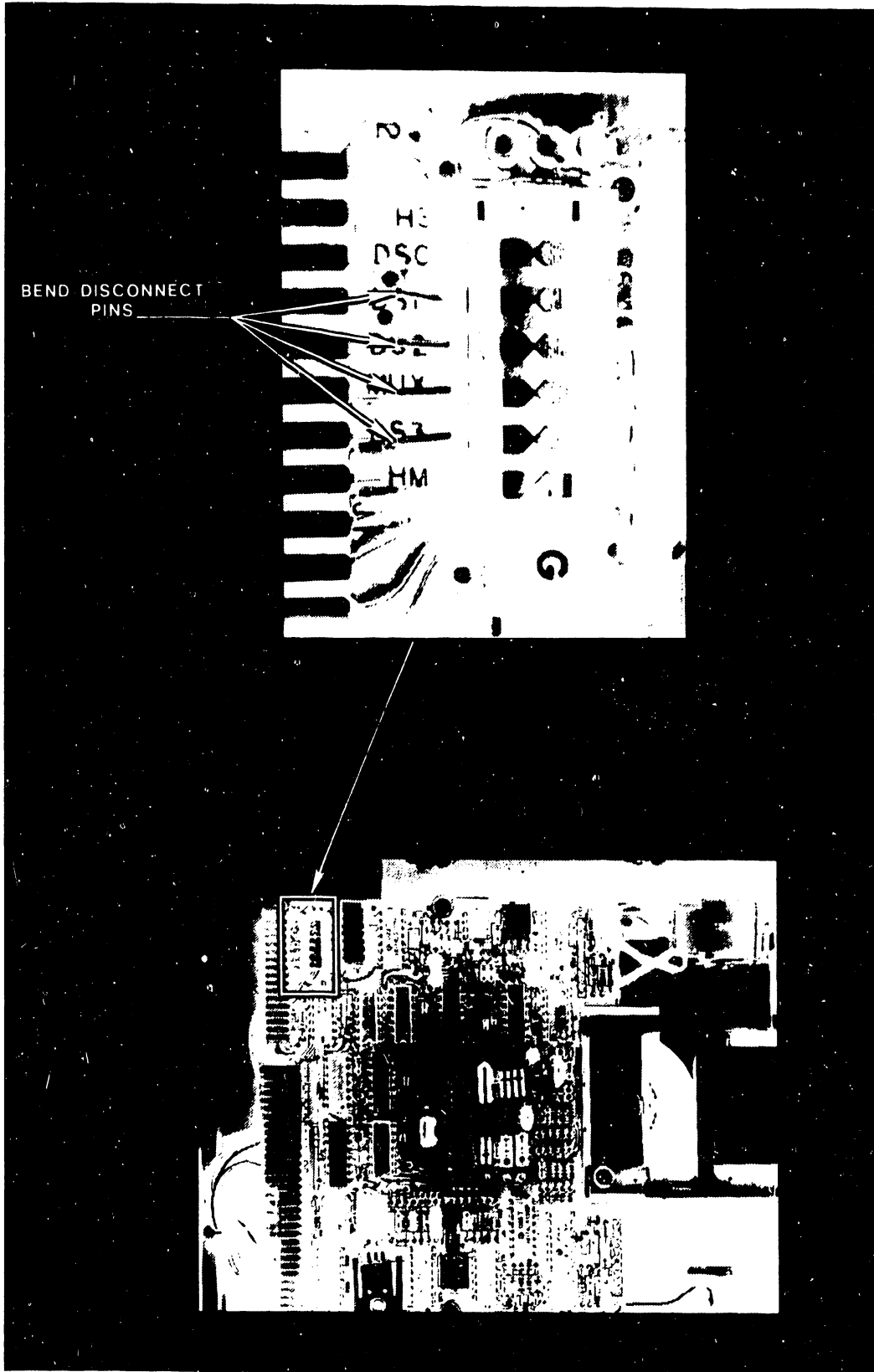

FIGURE 9 JUMPER BLOCK CONNECTIONS - MPI DRIVE

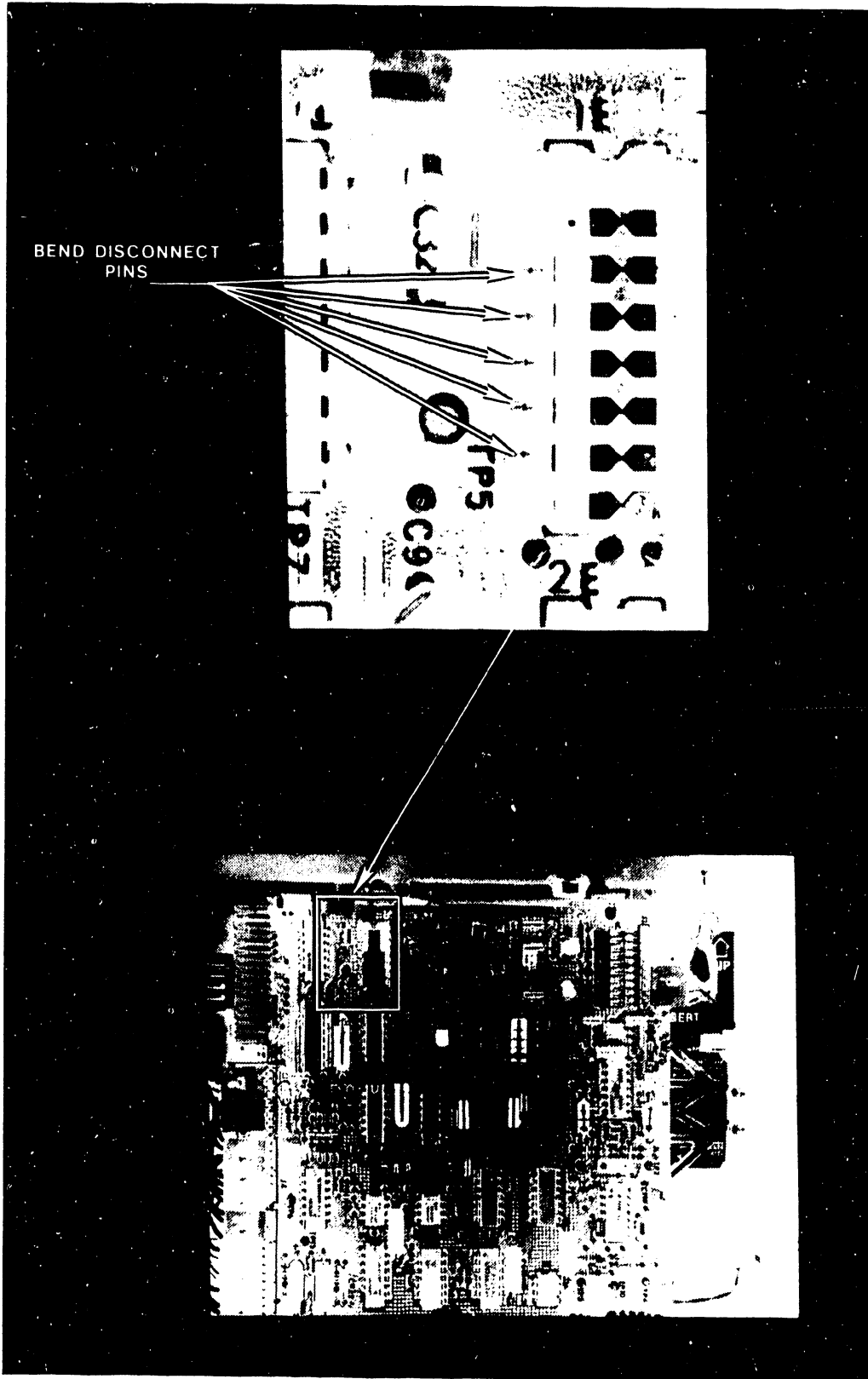

FIGURE 10 JUMPER BLOCK CONNECTIONS TANDON DRIVE

- s. After the disk tests are run without error for several passes:
 - 1. Install right cabinet cover
 - 2. Close disk drive doors.
 - 3. Install new dual disk left cover.
- t. Attach Model 5503D identification sticker on the rear of the cabinet.

APPENDIX

D

MEMORY

ADDRESS

TABLES

APPENDIX D

MEMORY ADDRESS TABLES

The following tables list the addressing of the system RAM and the memory elements serving the CRT display. Tables D-1 and D-2 list the memory addressing of Models 5503 and 5504 respectively. Table C-3 lists the memory locations serving the character rows of the CRT display (applicable to both models).

TABLE D-1

MEMORY ADDRESS TABLE - MODEL 5503

0000 - 3FFF 16K Program RAM bank 0
 4000 - 7FFF 16K Program RAM bank 1
 8000 - BFFF Paged Memory - Bank 2:

<u>PG2</u>	<u>PG1</u>	<u>PG0</u>	
0	0	0	16K Program RAM bank 2
0	0	1	16K Program RAM bank 2
0	1	0	16K Program RAM bank 2
0	1	1	16K Program RAM bank 2

C000 - FFFF CRT Display Memory (see Table C-3)

D800 - DF7F Soft Loadable Character Generator (Write Only):

Row	Char 1	Char 128
1	D800	D87F
2	D900	D97F
3	DA00	DA7F
4	DB00	DB7F
5	DC00	DC7F
6	DD00	DD7F
7	DE00	DE7F
8	DF00	DF7F

TABLE D-2

MEMORY ADDRESS TABLE (MODEL 5504)

0000 - 3FFF 16K Program RAM Bank 0
 4000 - 7FFF 16K Program RAM Bank 1
 8000 - BFFF Paged Memory - Bank 2:

<u>M2</u>	<u>M1</u>	<u>PG1</u>	<u>PG0</u>	
0	0	0	0	16K RAM
0	0	0	1	16K RAM
0	0	1	0	16K RAM
0	0	1	1	16K RAM

C000 - FFFF Paged Memory - Bank 3:

<u>M2</u>	<u>M1</u>	<u>PG1</u>	<u>PG0</u>	
0	0	0	0	8K CRT Soft Character Generator
0	1	0	0	16K RAM
1	0	0	0	16K CRT Character/Attribute Control*
1	1	0	0	16K RAM

*See Table D-3

Table D-3

CRT DISPLAY MEMORY ROW/COLUMN ADDRESSES
(MODELS 5503/5504)

C000 - FFFF CRT Display Memory

ROW	Attribute		Data	
	COL	1.....80	1.....80	
1	C000	C04F	E000	E04F
2	C100	C14F	E100	E14F
3	C200	C24F	E200	E24F
4	C300	C34F	E300	E34F
5	C400	C44F	E400	E44F
6	C500	C54F	E500	E54F
7	C600	C64F	E600	E64F
8	C700	C74F	E700	E74F
9	C800	C84F	E800	E84F
10	C900	C94F	E900	E94F
11	CA00	CA4F	EA00	EA4F
12	CB00	CB4F	EB00	EB4F
13	CC00	CC4F	EC00	EC4F
14	CD00	CD4F	ED00	ED4F
15	CE00	CE4F	EE00	EE4F
16	CF00	CF4F	EF00	EF4F
17	D000	D04F	F000	F04F
18	D100	D14F	F100	F14F
19	D200	D24F	F200	F24F
20	D300	D34F	F300	F34F
21	D400	D44F	F400	F44F
22	D500	D54F	F500	F54F
23	D600	D64F	F600	F64F
24	D700	D74F	F700	F74F

CHAPTER

6

SYSTEM

SCHE-

MATICS

CHAPTER 6
SYSTEM SCHEMATICS

This chapter contains the schematics for the principal electronic assemblies for the Wangwriter Models 5503 and 5504/5524. Drawing numbers, and nomenclature, are as follows:

7456	Electronics for 9" and 12" Monitor
7771*	FTC Board
7775** 7975*	CRT/Memory Board
7776** 7976*	Printer Driver Board
7777** 7977*	CPU/Disk Keyboard
7778**	Regulator
7782	Switch Panel
8278*	Ferro Regulator Board
725-2635	Keytronic Keyboard

*5504/5524 Models only

**5503 Models only

THE INFORMATION CONTAINED IN THIS DRAWING IS THE PROPERTY OF WANG LABORATORIES, INC. AND IS CONFIDENTIAL AND PROPRIETARY TO WANG LABORATORIES, INC. IT MAY NOT BE COPIED, REPRODUCED OR USED IN WHOLE OR IN PART FOR ANY REASON.

MILLIMETERS IN PARENTHESIS TOLERANCES TO BE EQUIVALENT TO INCH DIMENSIONS

HOLE LEGEND & TOLERANCES		
HOLE DIA	TOLERANCE	
013	± .001	001
014	± .001	001
015	± .001	001

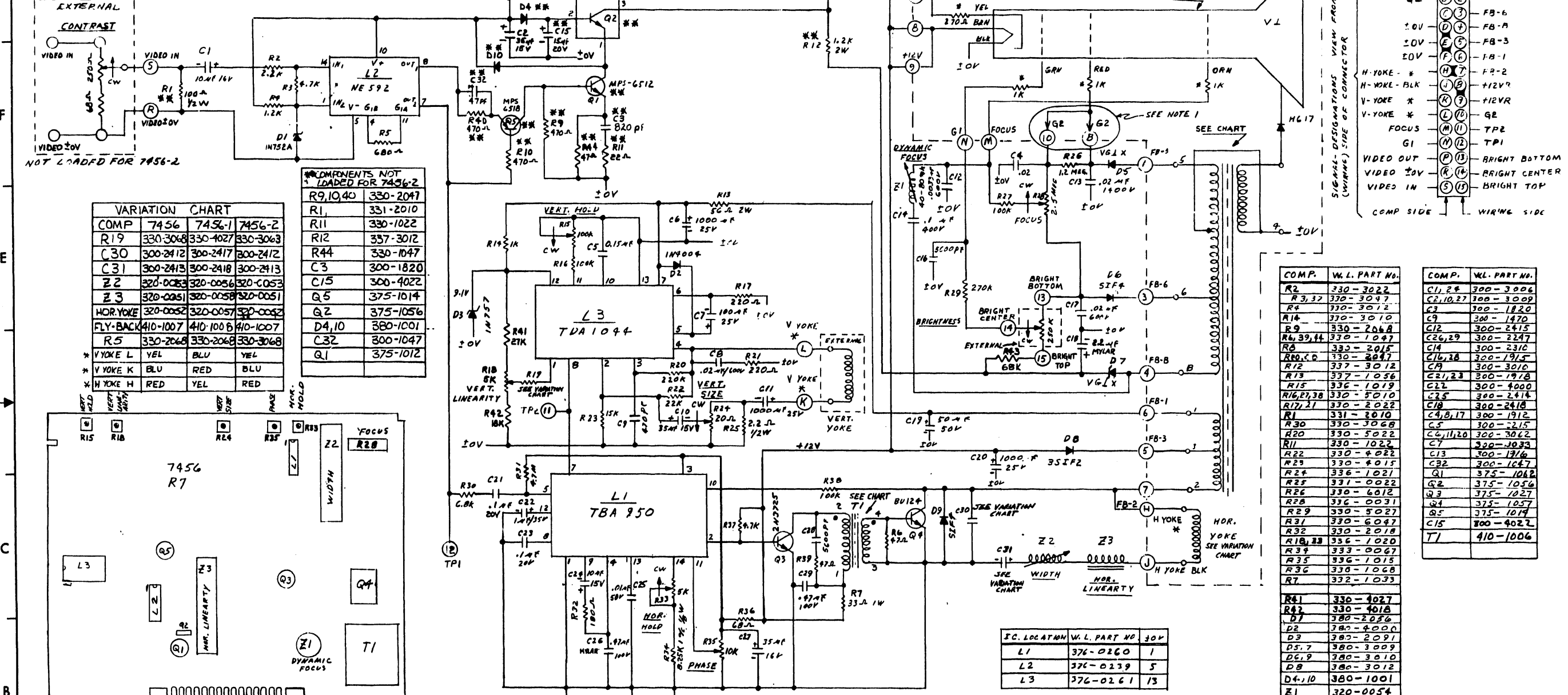

VARIATION CHART			
COMP	7456	7456-1	7456-2
R19	330-3068	330-4027	330-3063
C30	300-2412	300-2417	300-2412
C31	300-2413	300-2418	300-2413
Z2	320-0053	320-0056	320-0053
Z3	320-0051	320-0058	320-0051
HOR. YOKE	320-0052	320-0057	320-0052
FLY-BACK	410-1007	410-1008	410-1007
R5	330-2068	330-2068	330-3068
* V YOKE L	YEL	BLU	YEL
* V YOKE K	BLU	RED	BLU
* H YOKE H	RED	YEL	RED

COMPONENTS NOT LOADED FOR 7456-2	
R9,10,40	330-2047
R1	331-2010
R11	330-1022
R12	337-3012
R44	330-1047
C3	300-1820
C15	300-4022
Q5	375-1014
Q2	375-1056
D4,10	380-1001
C32	300-1047
Q1	375-1012

COMP.	WL.	PART NO.
R2	330-3022	
R3,37	330-3047	
R4	330-3012	
R14	370-3010	
R9	330-2068	
R4,39,44	330-1047	
R4	330-2015	
R40,40	330-2047	
R12	337-3012	
R13	337-1056	
R15	336-1019	
R16,17,38	330-5010	
R17,21	330-2022	
R1	331-3010	
R30	330-3068	
R20	330-5022	
R11	330-1022	
R22	330-4022	
R8	330-4015	
R24	336-1021	
R25	331-1022	
R26	330-6012	
R29	336-0031	
R29	330-5027	
R31	330-6047	
R32	330-2018	
R18,28	336-1020	
R34	333-0067	
R35	336-1015	
R36	336-1068	
R7	332-1033	
R41	330-4027	
R42	330-4018	
D1	380-2056	
D2	380-4000	
D3	380-2091	
D5,7	380-3009	
D6,9	380-3010	
D8	380-3012	
D4,10	380-1001	
Z1	320-0054	
R43	330-4068	

COMP.	WL.	PART NO.
C1,2,4	300-3006	
C2,10,27	300-3009	
C3	300-1820	
C9	300-1470	
C12	300-2415	
C26,29	300-2247	
C14	300-2310	
C16,18	300-1915	
C9	300-3010	
C21,23	300-1918	
C25	300-4000	
C25	300-2414	
C18	300-2418	
C4,8,17	300-1912	
C5	300-2415	
C6,11,20	300-3062	
C7	320-3033	
C13	300-1916	
C32	300-1647	
Q1	375-1048	
Q2	375-1056	
Q3	375-1027	
Q4	375-1057	
Q5	375-1014	
C15	300-4022	
T1	410-1006	

IC LOCATION	W.L.	PART NO.	30V
L1	376-0260	1	
L2	376-0239	5	
L3	376-0261	13	

NOTES:
1. CONNECT G2 LEAD TO PIN B UNLESS UNABLE TO ACHIEVE RASTER CUT OFF.

E-REV 7456
E-REV 7456-1
E-REV 7456-2

REV	DATE	BY	DESCRIPTION
1	12-10-77	WJR	REVISED PER ECN # 17052
2	12-10-77	WJR	REVISED PER ECN # 17052
3	12-10-77	WJR	REVISED PER ECN # 17052
4	12-10-77	WJR	REVISED PER ECN # 17052
5	12-10-77	WJR	REVISED PER ECN # 17052
6	12-10-77	WJR	REVISED PER ECN # 17052
7	12-10-77	WJR	REVISED PER ECN # 17052
8	12-10-77	WJR	REVISED PER ECN # 17052
9	12-10-77	WJR	REVISED PER ECN # 17052
10	12-10-77	WJR	REVISED PER ECN # 17052
11	12-10-77	WJR	REVISED PER ECN # 17052

QTY.	ITEM	WANG PART NO.	DRAWING NO.	DESCRIPTION
	WANG			WANG MONITOR
				ELECTRONICS FOR 9" AND 12" MONITOR

THIS DRAWING AND THE DATA SHOWN THERE ON ARE THE CONFIDENTIAL PROPERTY OF AND ARE PROPRIETARY TO WANG LABORATORIES, INC. THIS DRAWING AND THE DATA SHOWN THEREON MAY NOT BE MADE PUBLIC WITHOUT THE WRITTEN CONSENT OF WANG LABORATORIES, INC. IF FOR ANY REASON THIS DRAWING IS PERMITTED BY WANG TO LEAVE THE PHYSICAL CUSTODY OF THE COMPANY, IT IS RETURNABLE UPON THE DEMAND OF WANG LABORATORIES, INC.

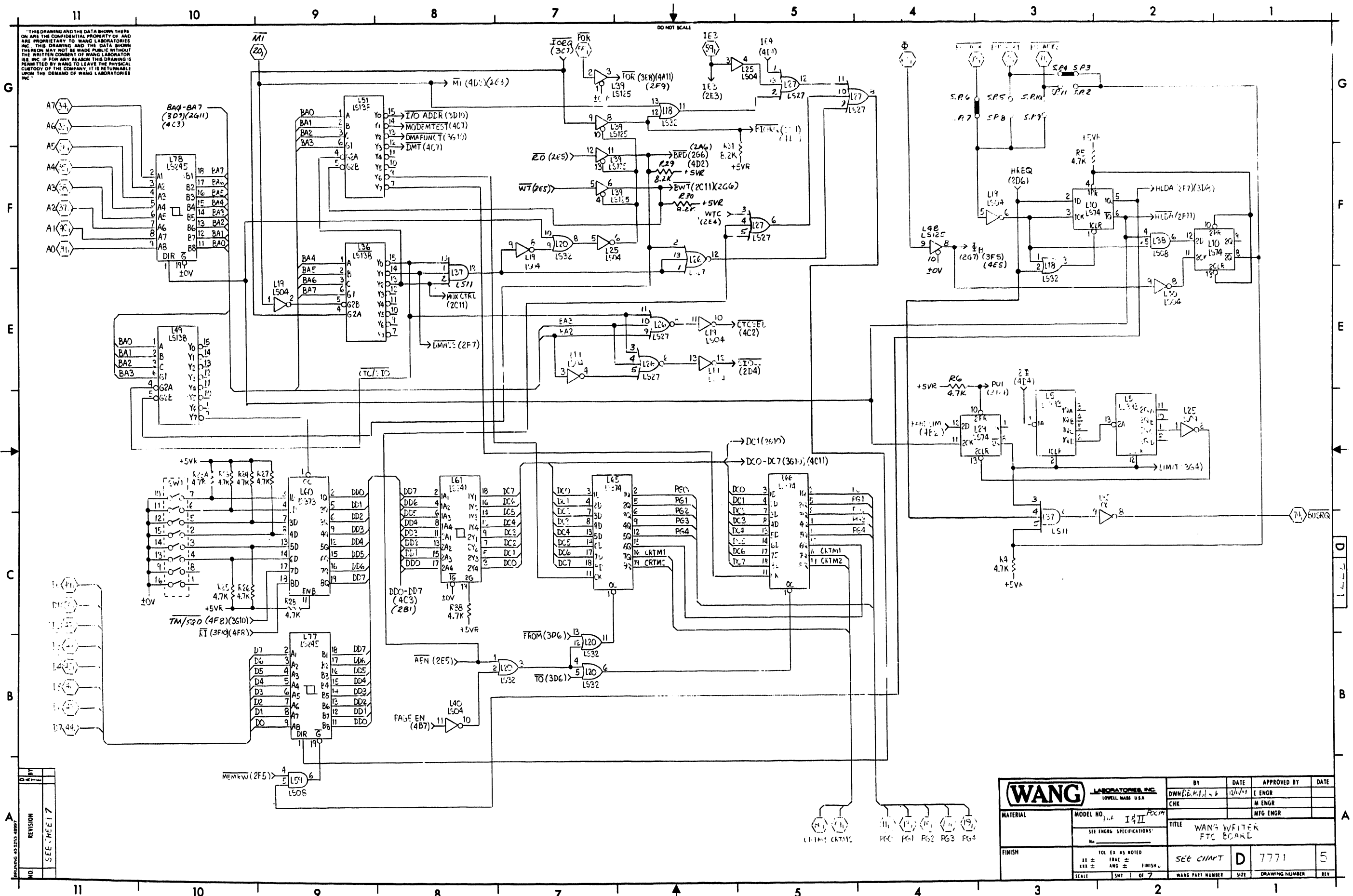

NO.	REVISION
1	SEE SHEET 17

WANG LABORATORIES, INC. LOWELL, MASS. U.S.A.		BY	DATE	APPROVED BY	DATE
MATERIAL		DWN: E.H.I./...	12/1/71	E ENGR	
MODEL NO. I 1/2 II		CHK		M ENGR	
SEE ENGR SPECIFICATIONS		TITLE		WANG WRITER FTC BOARD	
FINISH		SCALE		SEE CHMT	
101 EX AS NOTED		SCALE		D 7771 5	
XX ± FRACTION		SCALE		WANG PART NUMBER	
XXX ± ANG ± FINISH		SCALE		SIZE	
SCALE		SMT / OF 7		DRAWING NUMBER	
				REV	

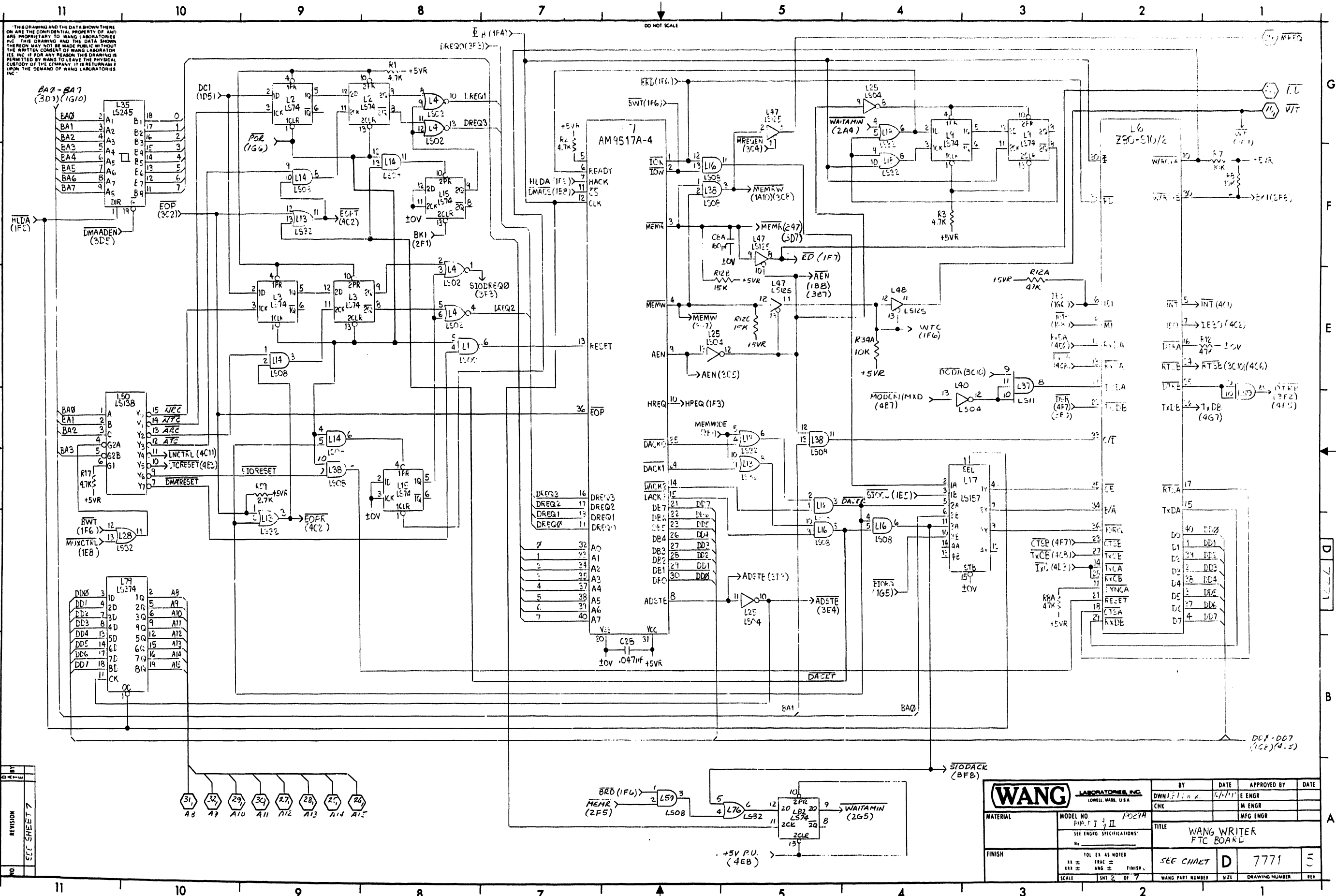

THIS DRAWING AND THE DATA SHOWN THERE ON ARE THE CONFIDENTIAL PROPERTY OF AND ARE PROPRIETARY TO WANG LABORATORIES, INC. THIS DRAWING AND THE DATA SHOWN THEREIN MAY NOT BE MADE PUBLIC WITHOUT THE WRITTEN CONSENT OF WANG LABORATORIES, INC. IF FOR ANY REASON THIS DRAWING IS PERMITTED BY WANG TO LEAVE THE PHYSICAL CUSTODY OF THE COMPANY, IT IS RETURNABLE UPON THE DEMAND OF WANG LABORATORIES, INC.

NO.	REVISION	DATE	BY	CHK
1	ELL SHEET 7			

WANG LABORATORIES, INC.		BY	DATE	APPROVED BY	DATE
LOWELL, MASS. U.S.A.		DWNI	10/1/71	E ENGR	
MATERIAL		CHK		M ENGR	
MODEL NO. PWR. I, II, P027A		TITLE			
SEE ENGRG. SPECIFICATIONS		WANG WRITER FTC BOARD			
FINISH		SEE CHART		D	7771
TOL. IS AS NOTED		WANG PART NUMBER		SIZE	DRAWING NUMBER
11 ±		SCALE		INT. 2	OF 7
133 ±		ANG. ±			
FINISH ±		WANG PART NUMBER		SIZE	DRAWING NUMBER
SCALE		INT. 2		OF 7	

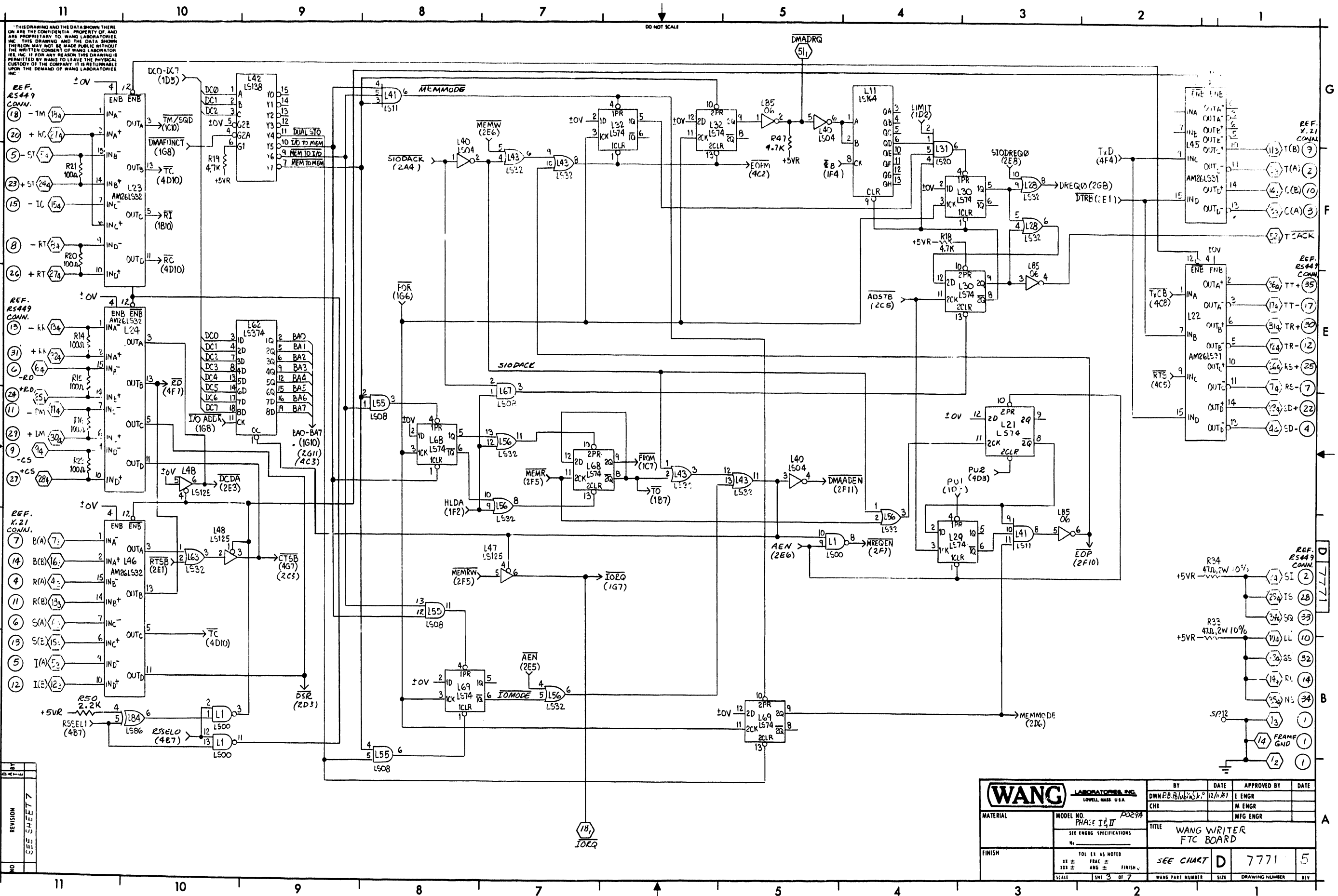

WANG LABORATORIES, INC. LOWELL, MASS. U.S.A.		BY	DATE	APPROVED BY	DATE
MATERIAL	MODEL NO. PHASE I, II	DWN.P.B. B11/12/13/14	12/1/81	E ENGR	
FINISH	SEE ENGR SPECIFICATIONS	CHK		M ENGR	
TITLE		MFG ENGR			
SEE CHART D		7771 5			
SCALE		WANG PART NUMBER			
SMT 3 OF 7		SIZE			
DRAWING NUMBER		REV			

REV	DATE	BY	DESCRIPTION
1			
2			
3			
4			
5			

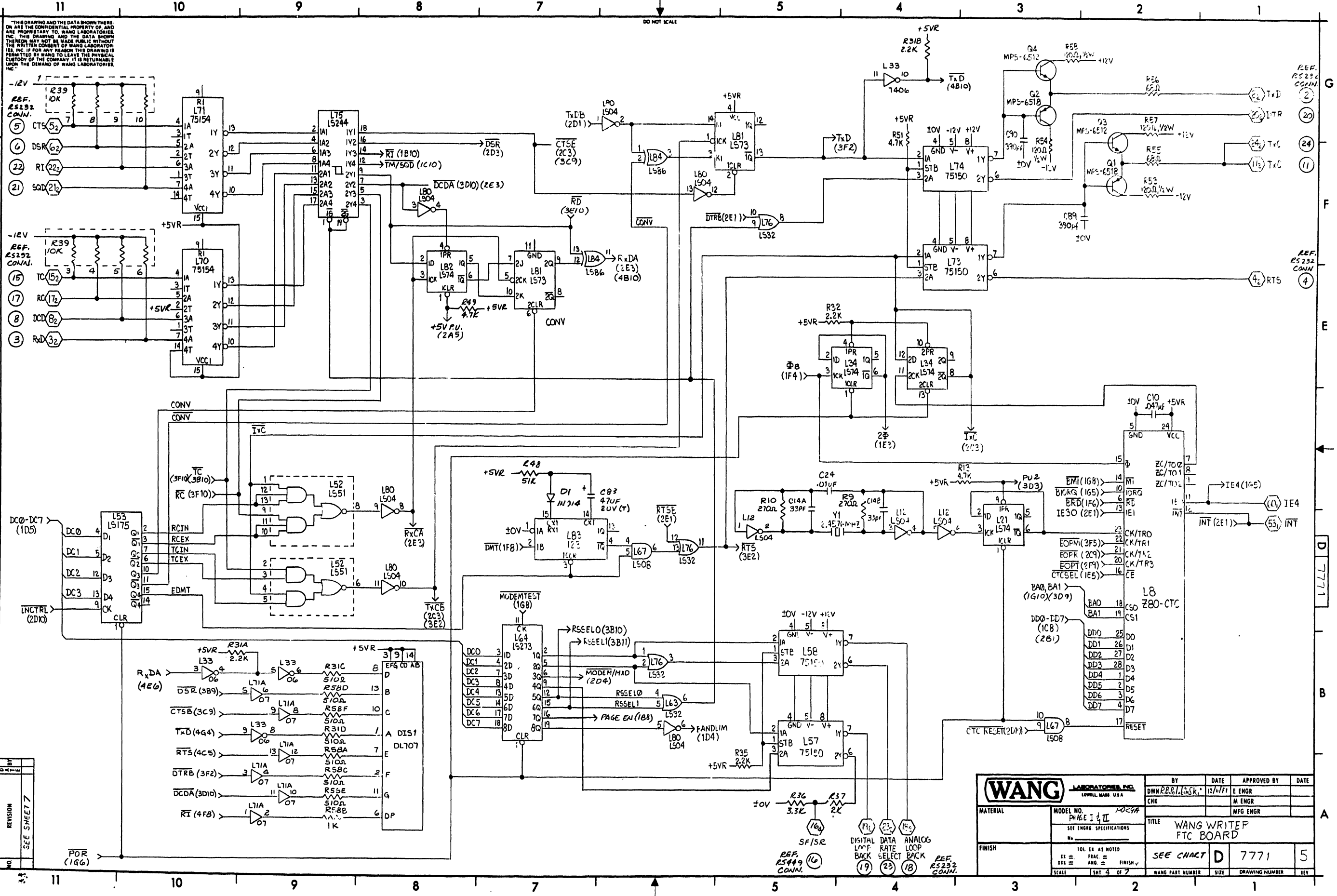

THIS DRAWING AND THE DATA SHOWN THEREON ARE THE CONFIDENTIAL PROPERTY OF, AND ARE PROPRIETARY TO, WANG LABORATORIES, INC. THIS DRAWING AND THE DATA SHOWN THEREON MAY NOT BE MADE PUBLIC WITHOUT THE WRITTEN CONSENT OF WANG LABORATORIES, INC. IF FOR ANY REASON THIS DRAWING IS PERMITTED BY WANG TO LEAVE THE PHYSICAL CUSTODY OF THE COMPANY, IT IS RETURNABLE UPON THE DEMAND OF WANG LABORATORIES, INC.

NO.	REVISION	DATE	BY	APPROVED BY	DATE
1	SEE SHEET 7				

WANG LABORATORIES, INC. LOWELL, MASS. U.S.A.		BY DWN/EBR/LSK	DATE 12/1/71	APPROVED BY E ENGR	DATE
MATERIAL	MODEL NO. PHASE I & II	CHK M ENGR		MFG ENGR	
SEE ENGR SPECIFICATIONS		TITLE WANG WRITEP FTC BOARD			
FINISH	101 EX AS NOTED	11 ±	FRAC ±	FINISH ±	
	111 ±	ANG ±			
SCALE	1/8" = 1"	SHT 4 OF 7	WANG PART NUMBER	SIZE	DRAWING NUMBER
					7771
					5

11 10 9 8 7 5 4 3 2 1

DO NOT SCALE

THIS DRAWING AND THE DATA SHOWN THEREIN ARE THE CONFIDENTIAL PROPERTY OF WANG AND ARE PROPRIETARY TO WANG LABORATORIES, INC. THIS DRAWING AND THE DATA SHOWN THEREON MAY NOT BE MADE PUBLIC WITHOUT THE WRITTEN CONSENT OF WANG LABORATORIES, INC. IF FOR ANY REASON THIS DRAWING IS PERMITTED BY WANG TO LEAVE THE PHYSICAL POSSESSION OF THE COMPANY IT IS RETURNABLE UPON THE DEMAND OF WANG LABORATORIES, INC.

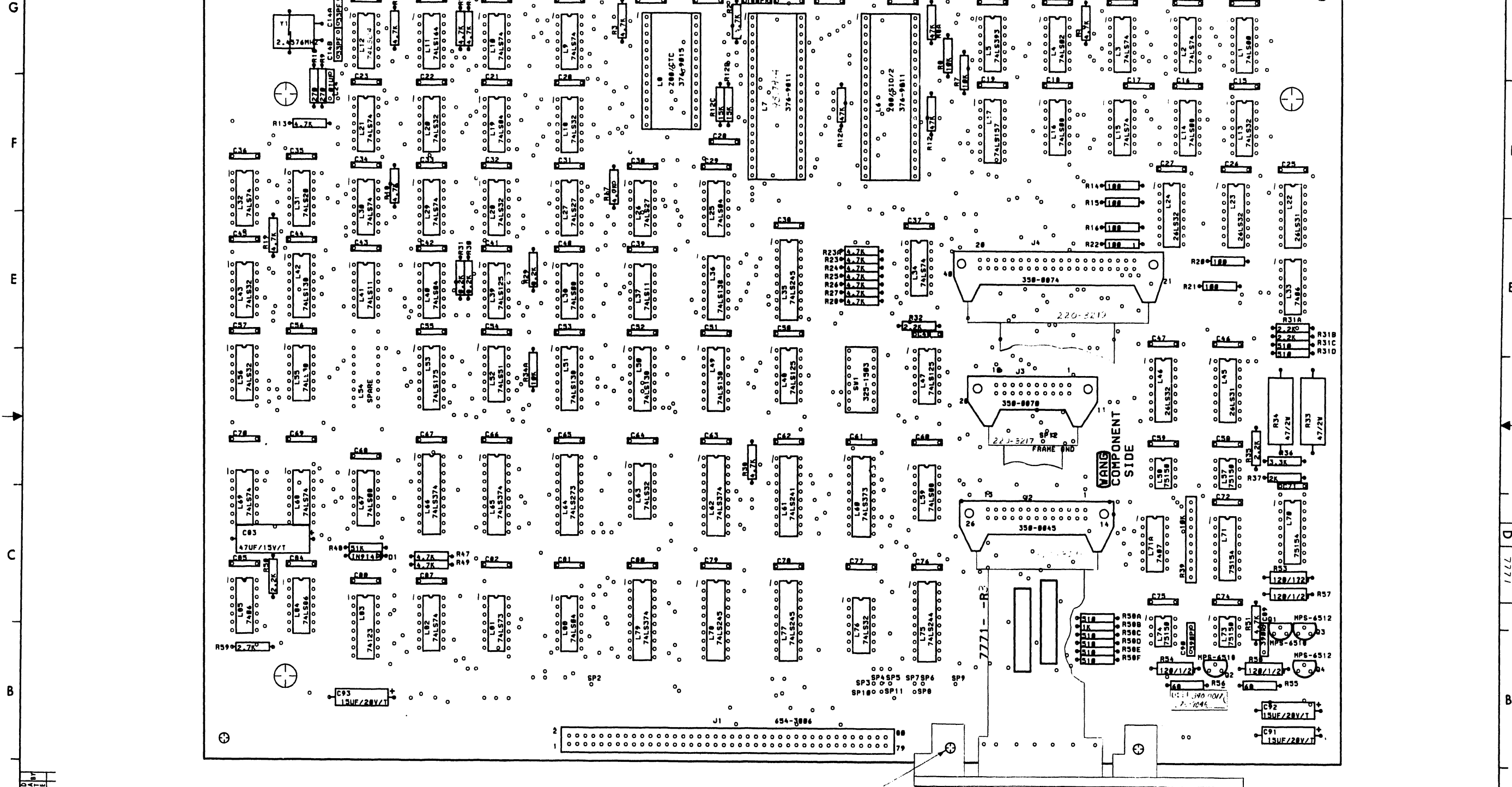

G
F
E
C
B
A

G
F
E
D
B
A

NO	REVISION
	SEE SHEET 7

650-2097(2)
NOTE: CAPS IN...
...KEY

		BY: DWM/D DATE: 5/1/64 APPROVED BY: M ENGR DATE:
MATERIAL	MODEL NO: 7021A PART I & II SEE ENG'G SPECIFICATIONS	TITLE: WANG WRITER FTC BOARD
FINISH	101 IS AS NOTED 102 = FINISH 103 = FINISH SCALE: 5/8" = 1"	SEE CHART D 7771 WANG PART NUMBER: 7771 SIZE: DRAWING NUMBER: 7771

11 10 9 8 7 5 4 3 2 1

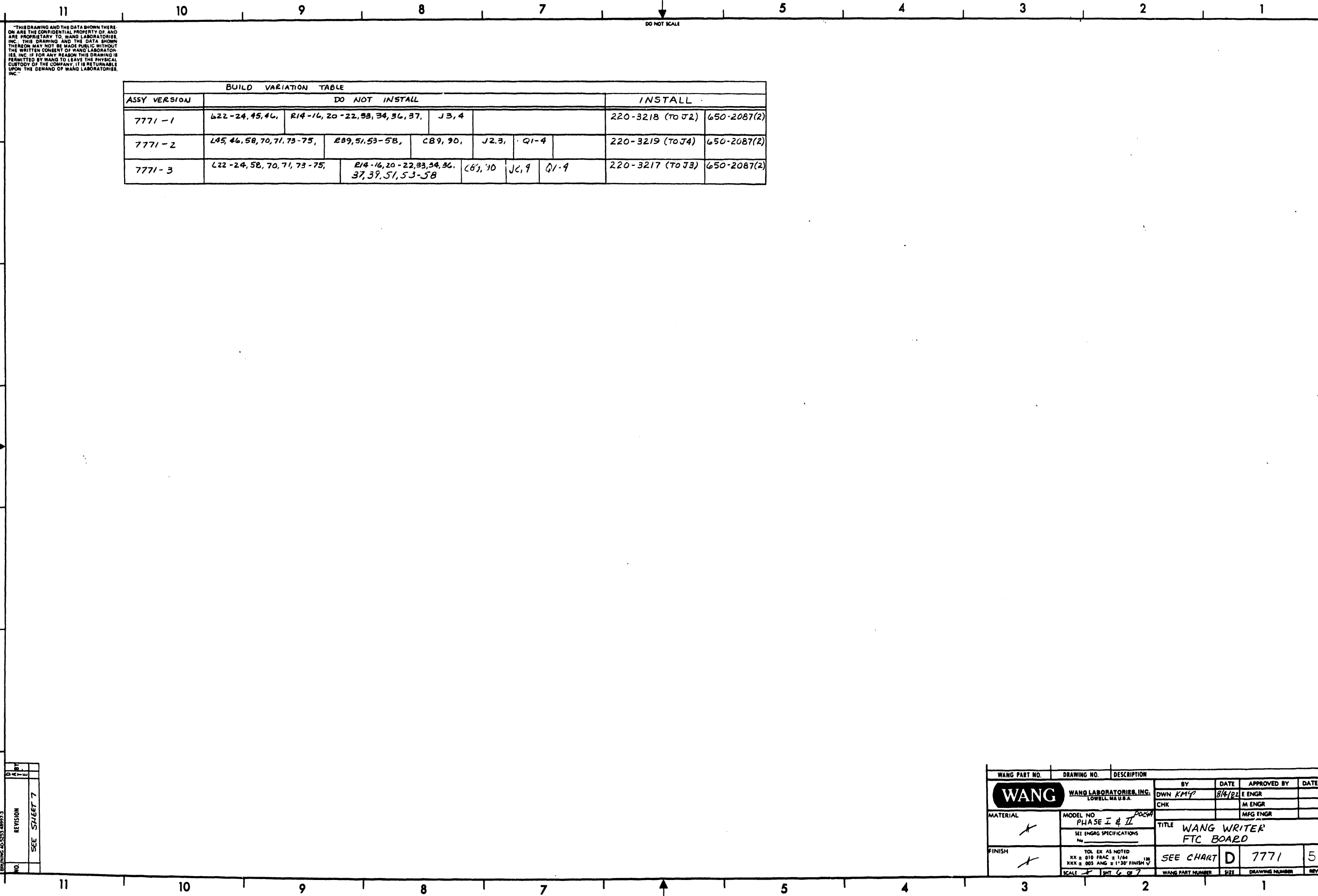

THIS DRAWING AND THE DATA SHOWN THEREON ARE THE CONFIDENTIAL PROPERTY OF AND ARE PROPRIETARY TO WANG LABORATORIES, INC. THIS DRAWING AND THE DATA SHOWN THEREON MAY NOT BE MADE PUBLIC WITHOUT THE WRITTEN CONSENT OF WANG LABORATORIES, INC. IF FOR ANY REASON THIS DRAWING IS PERMITTED BY WANG TO LEAVE THE PHYSICAL CUSTODY OF THE COMPANY, IT IS RETURNABLE UPON THE DEMAND OF WANG LABORATORIES, INC.

DO NOT SCALE

ASSY VERSION	BUILD VARIATION TABLE						INSTALL	
	DO NOT INSTALL							
7771-1	L22-24, 45, 46,	R14-16, 20-22, 53, 34, 36, 37,	J3, 4				220-3218 (TO J2)	650-2087(2)
7771-2	L45, 46, 58, 70, 71, 73-75,	R39, 51, 53-58,	C89, 90,	J2, 3,	Q1-4		220-3219 (TO J4)	650-2087(2)
7771-3	L22-24, 58, 70, 71, 73-75,	R14-16, 20-22, 33, 34, 36, 37, 39, 51, 53-58	C89, 90	J2, 3,	Q1-4		220-3217 (TO J3)	650-2087(2)

NO.	REVISION
	SEE SHEET 7

WANG PART NO.	DRAWING NO.	DESCRIPTION	BY	DATE	APPROVED BY	DATE
WANG	WANG LABORATORIES, INC. LOWELL, MA U.S.A.		OWN <i>KMY</i>	8/4/82	E ENGR	
MATERIAL	MODEL NO PHASE I & II		CHK		M ENGR	
	SEE ENGRG SPECIFICATIONS				MFG ENGR	
FINISH	TOL. EX. AS NOTED XX ± 0.10 FRAC ± 1/64 XXX ± 0.03 ANG ± 1'30" FINISH	TITLE WANG WRITER FTC BOARD				
	SCALE <i>F</i> SHT 6 OF 7	SEE CHART				
		D 7771				5
		WANG PART NUMBER	SIZE	DRAWING NUMBER	REV	

THIS DRAWING AND THE DATA SHOWN THEREON ARE THE CONFIDENTIAL PROPERTY OF AND ARE PROPRIETARY TO WANG LABORATORIES, INC. THIS DRAWING AND THE DATA SHOWN THEREON MAY NOT BE MADE PUBLIC WITHOUT THE WRITTEN CONSENT OF WANG LABORATORIES, INC. IF FOR ANY REASON THIS DRAWING IS PERMITTED BY WANG TO LEAVE THE PHYSICAL CUSTODY OF THE COMPANY, IT IS RETURNABLE UPON THE DEMAND OF WANG LABORATORIES, INC.

I.C. LOCATION	TYPE	W.L. PART NO.
L1	74LS00	376-0207
L2, 3, 9, 10, 15, 21, 29, 30, 32, 34, 68, 69, 82	74LS74	376-0155
L4	74LS02	376-0208
L5	74LS393	376-0307
L6	Z80-S10/2	SEE CHART
L7	9517A-4	SEE CHART
L8	Z80-CTC	SEE CHART
L11	74LS164	376-0236
L13, 18, 20, 28, 43, 56, 63, 76	74LS32	376-0211
L14, 16, 38, 55, 59, 67	74LS08	376-0153
L17	74LS157	376-0216
L12, 19, 25, 40, 80	74LS04	376-0180
L22, 45	AM26LS31	376-0470
L23, 24, 46	AM26LS32	376-0471
L26, 27	74LS27	376-0245
L31	74LS20	376-0210
L33, 54, 72	SPARE	
L35, 77, 78	74LS245	376-0285
L36, 42, 49-51,	74LS138	376-0294
L37, 41	74LS11	376-0225
L39, 47, 48,	74LS125	376-0486
L52	74LS51	376-0213
L53	74LS175	376-0160
L57, 58, 73, 74	75150	376-0076
L60	74LS373	376-0310
L61	74LS241	376-0284
L62, 65, 66, 79	74LS374	376-0286
L64	74LS273	376-0302
L70, 71	75154	376-0077
L75	74LS244	376-0288
L71A	7407	376-0056
L81	74LS73	376-0304
L83	74123	376-0080
L84	74LS86	376-0231
L33, B5	7406	376-0055
L6, 7	40 PIN SKT	376-9011
L8	28 PIN SKT	376-9015

COMPONENT	TYPE	W.L. PART NO.
R1-6, 13, 17-19, 23-28, 23A, 38, 47, 49, 51	4.7K, 1/4W, 5%	330-3048
R7, 8, 34A	10K, 1/4W, 5%	330-4011
R8A, 12, 12A	47K, 1/4W, 5%	330-4048
R12B, 12C	15K 1/4W 5%	330-4016
R9, 10	270Ω, 1/4W, 5%	330-2028
R14-16, 20-22	100Ω, 1/4W, 5%	330-2011
R29-31	8.2K, 1/4W, 5%	330-3083
R31A, 31B, 32, 35, 50	2.2K, 1/4W, 5%	330-3023
R33, 34	47Ω, 2W, 10%	337-1047
R59	2.7K, 1/4W, 5%	330-3028
R36	3.3K, 1/4W, 5%	330-3034
R37	2K, 1/4W, 5%	330-3021
R39	10K S1P	333-0809
R48	51K 1/4W 5%	330-4052
R31C, 31D, 58A, 58C-58F	510Ω 1/4W 5%	330-2052
R53, 54, 57, 58	120Ω, 1/2W, 5%	331-2013
R55, 56	68Ω, 1/4W, 5%	330-1069
R58B	1K 1/4W 5%	330-3011
C1-23, 25-48, 50-72, 74-82, 84, 85, 87, 88	.047μf	300-1966
C8A	180pf	300-1180
C24	.01μf	300-1960
C14A, 14B	33PF	300-1033
C83	47UF 20V(T)	300-4034
C89, 90	390PF	300-1390
C91-93	.15μf, 20V(T)	300-4022
Q1, Q2	MPS-651B	375-1014
Q3, Q4	MPS-6512	375-1012
D1	IN914	380-1012
SW1	SWITCH, 8-POS	325-1503
Y1	2.4576 Mhz	321-0027
J1	CONN	654-3006
J2	CONN	350-0045
J3	CONN	350-0070
J4	CONN	350-0074
LED DISPLAY	DL701	340-0017
LED SOCKET	14 PIN SOCKET	376-9046
CABLE ASSY	RS 232	220-3218
CABLE ASSY	RS 449	220-3219
CABLE ASSY	X.21	220-3217
SCREWS (8)	4-40 X 1/4 PAN HD	650-2087

REF - SEE CHART P.6

I.C. TYPE	LOCATION	SPARE
74504	L12	3
7406	L85	2
74LS08	L59	2
	L67	1
74LS11	L37	1
	L41	1
74LS20	L31	1
74LS32	L63	2
74123	L83	1
74LS74	L21	1
74LS86	L84	1

MNEMONICS	COORD
A0-A7	1F11
ANALOG LOOP BACK	4A4
AB-A15	2A10
B(A)	3C11
B(B)	3C11
BUSACK	1G4
BUSACK1	1G3
BUSACK2	1G3
BUSRG	1C1
C(A)	3F1
C(B)	3F1
CRTM1	1A5
CRTM2	1A5
CS+, CS-	3D11
CTS	4G11
DO-D7	1C11
DATA RATE SELECT	4A4
DCD	4E11
DIGITAL LOOP BACK	4A4
DM+, DM-	3D11
DMADACK	3F1
DMADRQ	3G5
DSR	4F11
DTR	4G1
FRAME GND	3B1

MNEMONICS	COORD
J(A)	3B11
J(B)	3B11
J(C)	3F11
IE3	1G6
IE4	4D1
INT	4C1
Φ	1G4
IORG	3A7
IS	3C1
LL	3B1
MI	1G9
MREQ	2G1
N ₅	3B1
PG0-PG4	1A4
POR	1G7
R(A)	3C11
R(B)	3C11
RC+	3G11
RC	4E11
RD-	3D11
RD+	3E11
RD	2G1
RI	4F11
RL	3B1
RR+, RR-	3E11
RS+, RS-	3E1
RT+, RT-	3F11
RTS	4E1
RxD	4E11
S(A)	3C11
S(B)	3B11
SD+, SD-	3D1
SF/SR	4A5
SI	3C1
SQ	3C1
SQD	4F11
SS	3B1
ST+, ST-	3F11
T(A)	3F1
T(B)	3F1
TC	4E11
TM-	3G11
TR+, TR-	3E1
TT+, TT-	3E1
TxC	4F1
TxD	4G1
WT	2G1

DO NOT SCALE

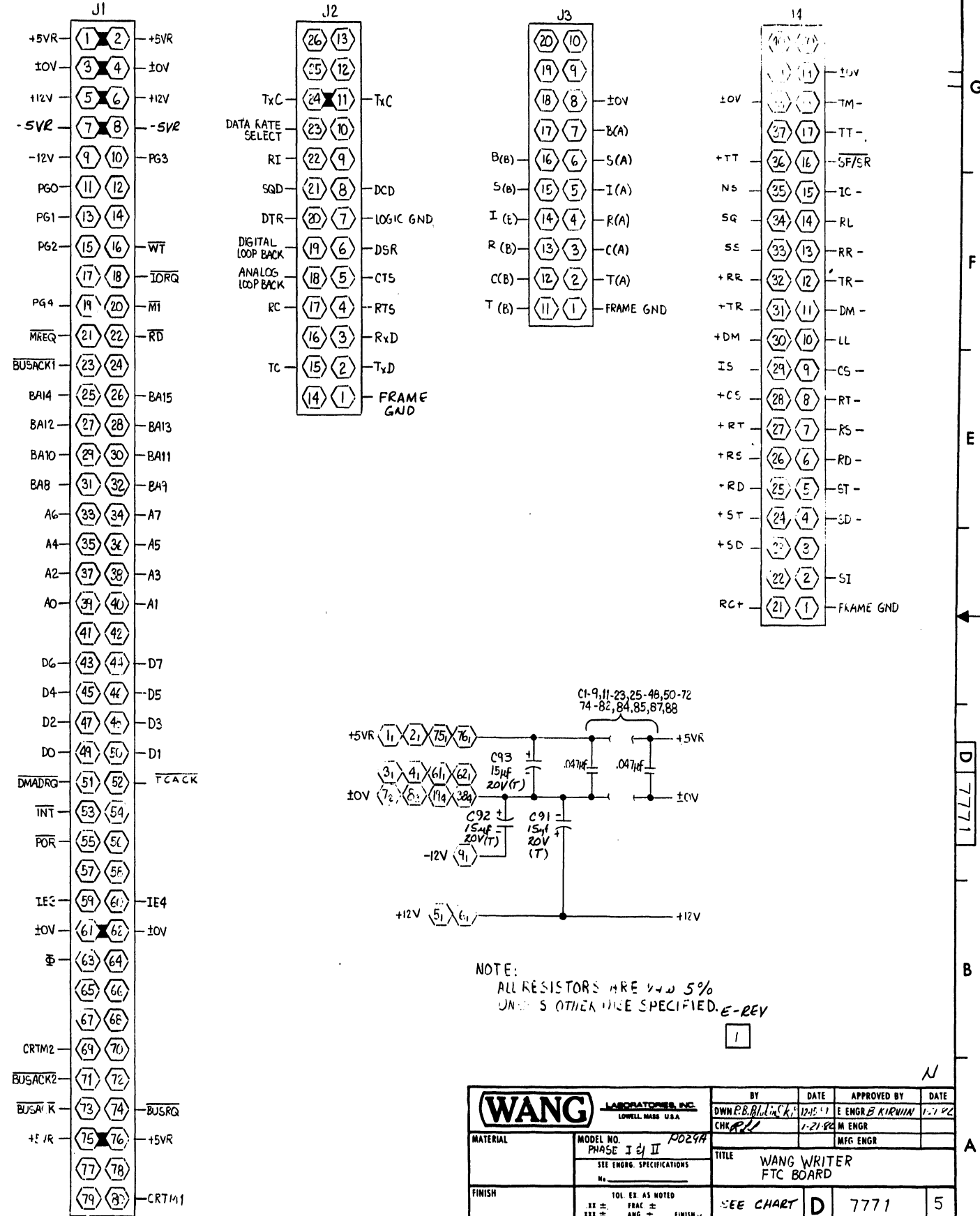

NOTE: ALL RESISTORS ARE 1/4W 5% UNLESS OTHERWISE SPECIFIED. E-REV

210 = 209 + 377 02 378				
210	209	L6	L7	L8
7771-A	7771	377-0393	377-0411	377-0435

NO.	REVISION	DATE	BY	CHKD	APP'D
1	ORIG PER DWR	10-21-82	WJ	WJ	WJ
2	REVISED PER ECO # 22751	11-22-82	WJ	WJ	WJ
3	REVISED PER ECO # 22920	12-22-82	WJ	WJ	WJ
4	REVISED PER ECO # 24638	1-22-83	WJ	WJ	WJ
5	REVISED PER ECO # 25395	2-27-83	WJ	WJ	WJ
6	REVISED PER ECO # 27396	3-24-83	WJ	WJ	WJ

WANG LABORATORIES, INC. LOWELL, MASS. U.S.A.		BY DWN.B.B. [Signature]	DATE 1-21-84	APPROVED BY E ENGR B. KIRWAN	DATE 1-27-84
MATERIAL		MODEL NO. PHASE I & II 0229A		TITLE WANG WRITER FTC BOARD	
FINISH		SCALE		SEE CHART	D 7771
NO. EX. AS NOTED		SHT 7 OF 7		WANG PART NUMBER	SIZE
XX ±		XXX ±		DRAWING NUMBER	
ANG ±		FINISH		BY	

"THIS DRAWING AND THE DATA SHOWN THEREON ARE THE CONFIDENTIAL PROPERTY OF WANG LABORATORIES, INC. THIS DRAWING AND THE DATA SHOWN THEREON MAY NOT BE MADE PUBLIC WITHOUT THE WRITTEN CONSENT OF WANG LABORATORIES, INC. IF FOR ANY REASON THIS DRAWING IS PERMITTED BY WANG TO LEAVE THE PHYSICAL CUSTODY OF THE COMPANY, IT IS RETURNABLE UPON THE DEMAND OF WANG LABORATORIES, INC."

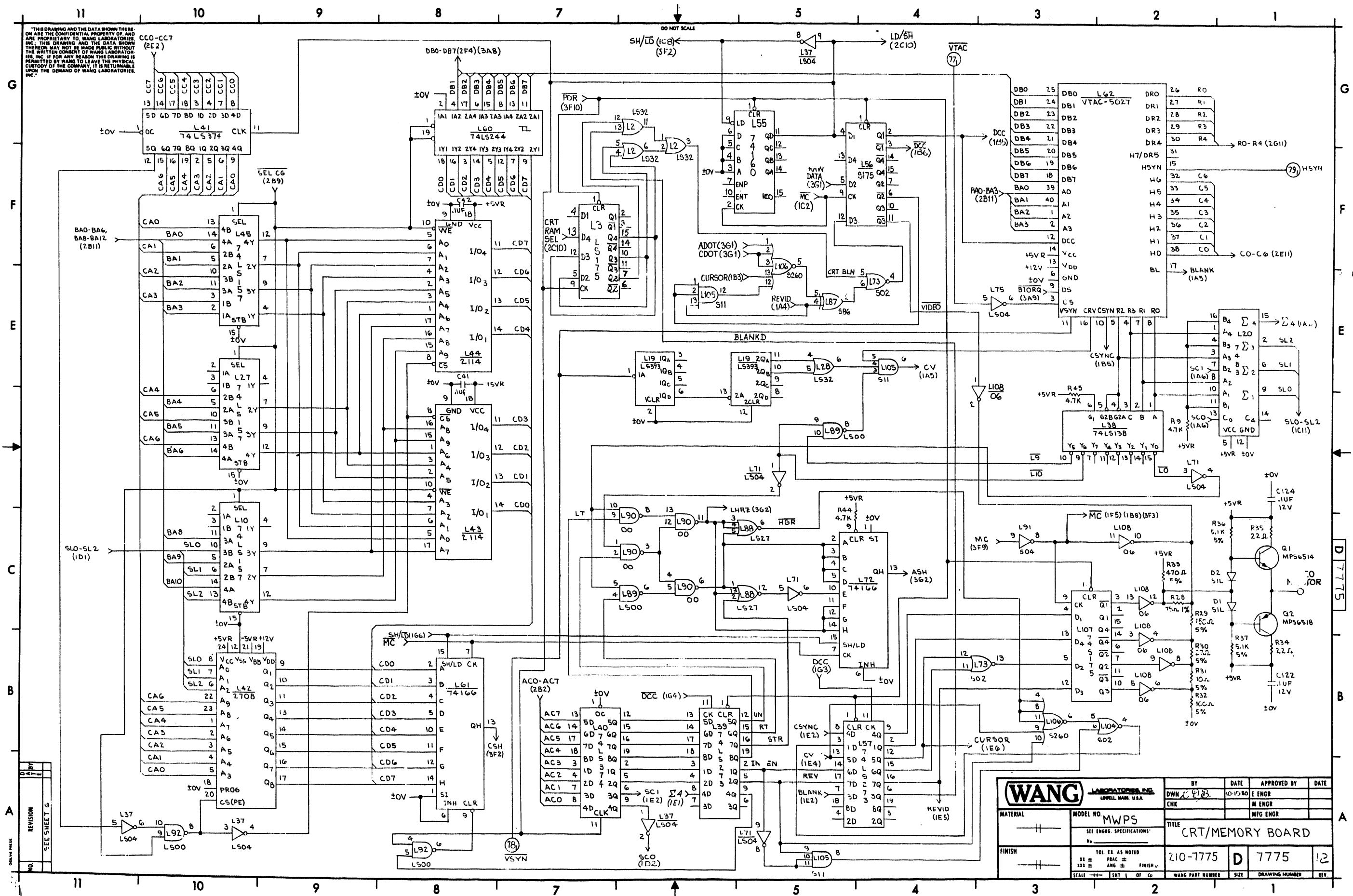

NO.	REVISION	SEE SHEET

WANG LABORATORIES, INC. LOWELL, MASS. U.S.A.		BY DWN (9) 83	DATE 10-15-80	APPROVED BY E ENGR	DATE
MATERIAL	MODEL NO. MWPS	CHK		M ENGR	
FINISH	TOL. EX. AS NOTED R1 ± R2 ± R3 ± SCALE	SEE ENGR. SPECIFICATIONS	TITLE CRT/MEMORY BOARD	210-7775	D 7775 12
			WANG PART NUMBER	SIZE	DRAWING NUMBER

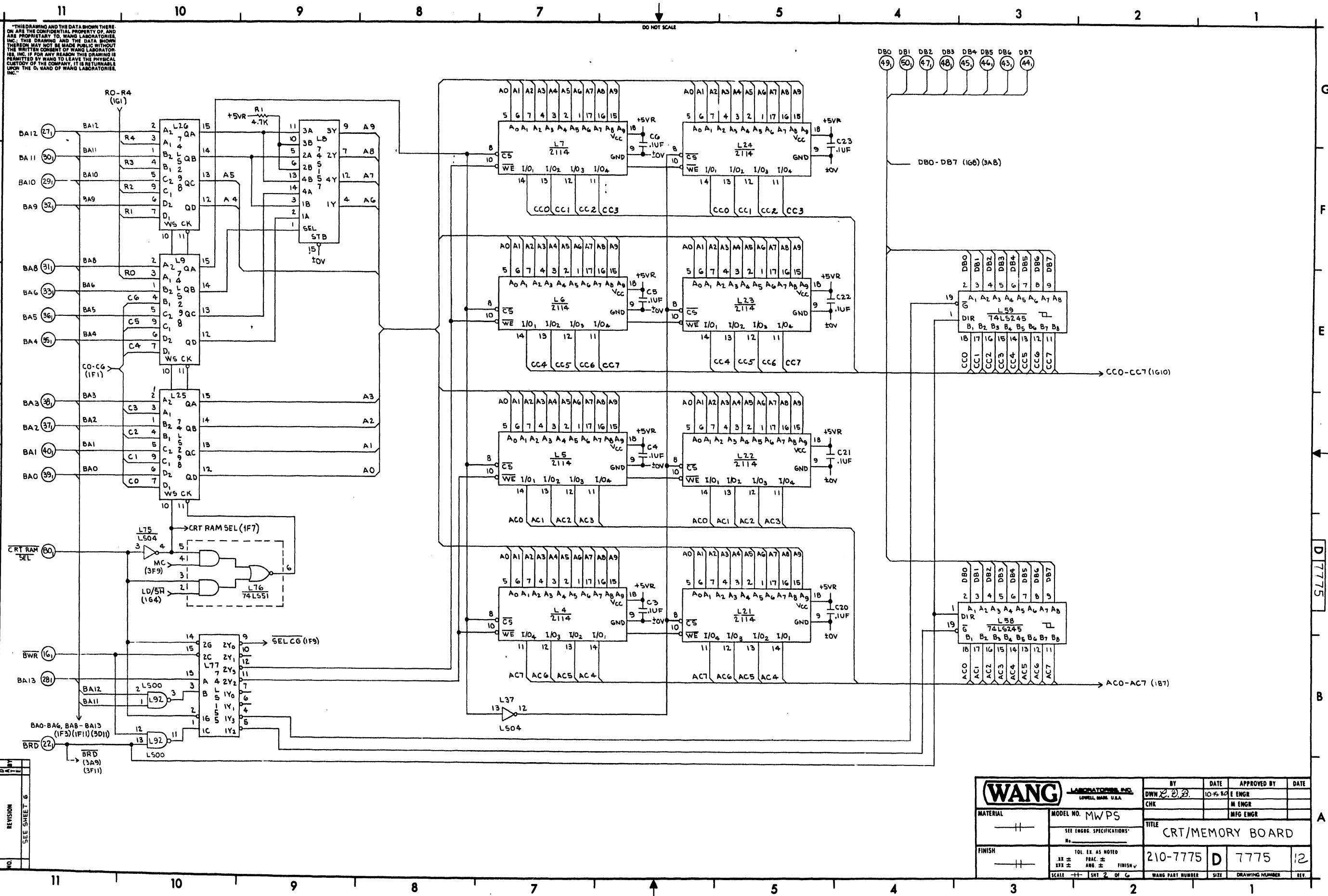

"THIS DRAWING AND THE DATA SHOWN THEREON ARE THE CONFIDENTIAL PROPERTY OF, AND ARE PROPRIETARY TO, WANG LABORATORIES, INC. THIS DRAWING AND THE DATA SHOWN THEREON MAY NOT BE MADE PUBLIC WITHOUT THE WRITTEN CONSENT OF WANG LABORATORIES, INC. IF FOR ANY REASON THIS DRAWING IS PERMITTED BY WANG TO LEAVE THE PHYSICAL CUSTODY OF THE COMPANY, IT IS RETURNABLE UPON THE DEMAND OF WANG LABORATORIES, INC."

DO NOT SCALE

NO.	REVISION
	SEE SHEET 6

WANG LABORATORIES, INC. LOWELL, MASS. U.S.A.		BY	DATE	APPROVED BY	DATE
		DWN	10-15-64	E ENGR	
MATERIAL: — — MODEL NO. MWPS SEE ENGR. SPECIFICATIONS* FINISH: — —		CHK		M ENGR	
				MFG ENGR	
TITLE		CRT/MEMORY BOARD			
210-7775		D	7775	12	
SCALE: — — SHT 2 OF 6		WANG PART NUMBER		SIZE	DRAWING NUMBER

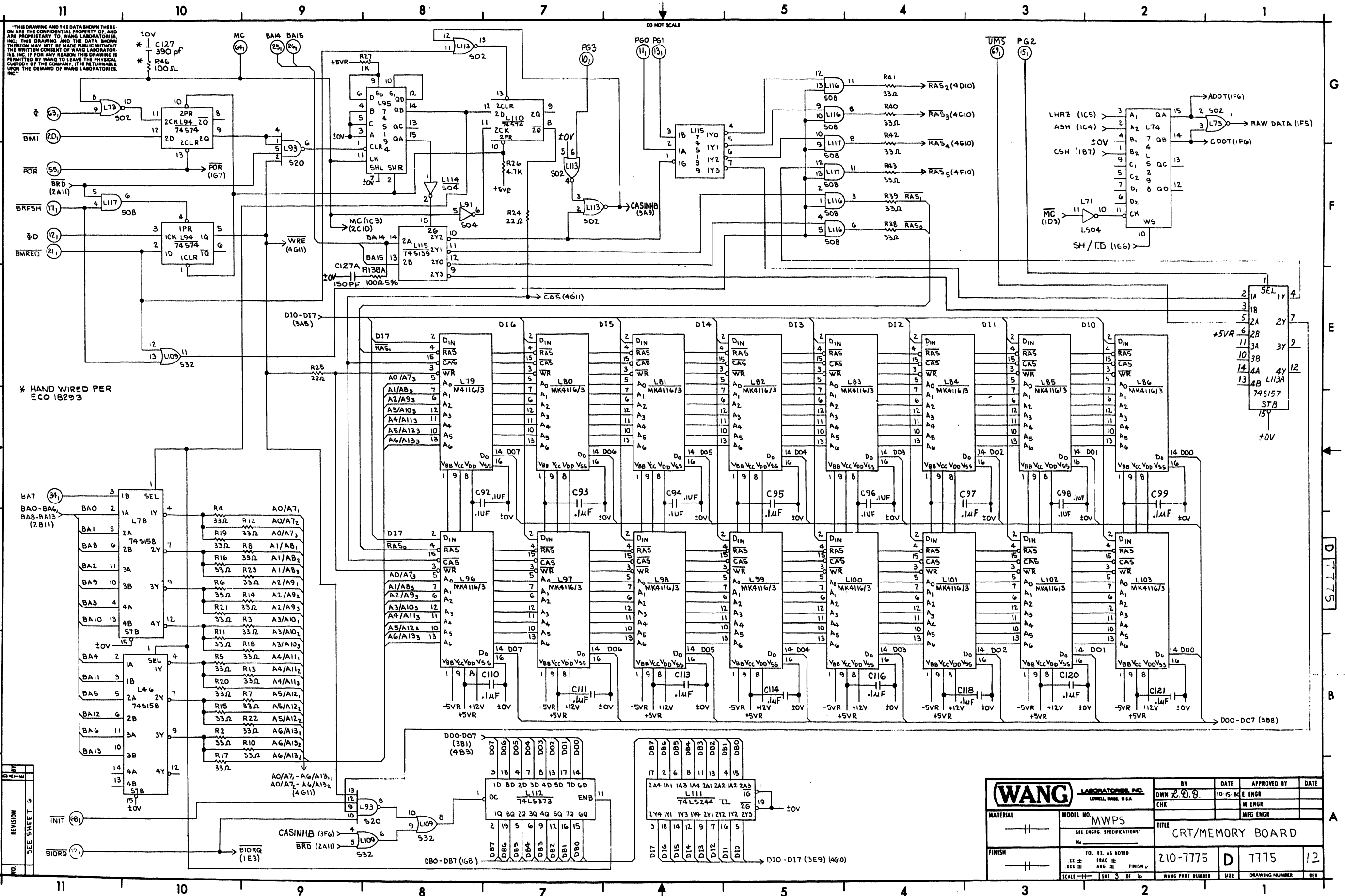

"THIS DRAWING AND THE DATA SHOWN THERE, ON ARE THE CONFIDENTIAL PROPERTY OF, AND ARE PROPRIETARY TO, WANG LABORATORIES, INC. THIS DRAWING AND THE DATA SHOWN THEREIN MAY NOT BE MADE PUBLIC WITHOUT THE WRITTEN CONSENT OF WANG LABORATORIES, INC. IF FOR ANY REASON THIS DRAWING IS PERMITTED BY WANG TO LEAVE THE PHYSICAL CUSTODY OF THE COMPANY, IT IS RETURNABLE UPON THE DEMAND OF WANG LABORATORIES, INC."

* HAND WIRED PER ECO 18293

REV	DATE	BY	DESCRIPTION
1			
2			
3			
4			
5			
6			
7			
8			
9			
10			
11			

WANG LABORATORIES, INC. LOWELL, MASS. U.S.A.		BY	DATE	APPROVED BY	DATE
MATERIAL		DWN	10-15-68	E ENGR	
MODEL NO. MWP5		CHK		M ENGR	
SEE ENGR. SPECIFICATIONS		TITLE		MFG ENGR	
FINISH		210-7775		D	7775
101. ER. AS NOTED		WANG PART NUMBER		SIZE	DRAWING NUMBER
11 ± FRACTION		210-7775		D	7775
132 ± ANG ± FINISH		WANG PART NUMBER		SIZE	DRAWING NUMBER
SCALE		SHT 3 OF 6			

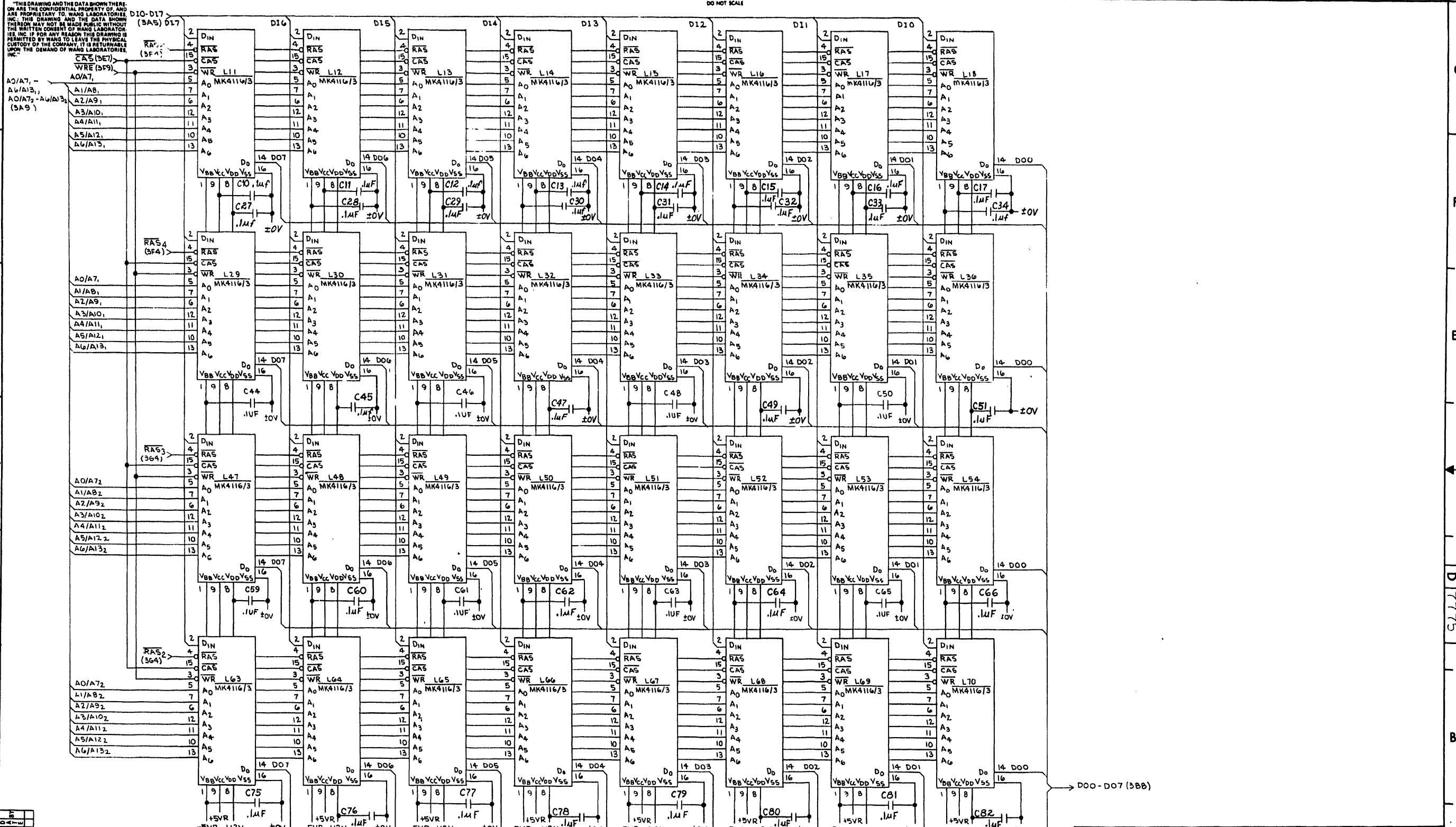

NO.	REVISION	SEE SHEET

WANG LABORATORIES, INC. LOWELL, MASS. U.S.A.		BY DWN L.D.B.	DATE 10-15-69	APPROVED BY E ENGR	DATE
MATERIAL — —		MODEL NO. MWPS	TITLE CRT/MEMORY BOARD		
FINISH — —		SEE ENGR SPECIFICATIONS	210-7775 D 7775 12		
SCALE 1:1		TOL EX AS NOTED FRAC. ± ANG. ± FINISH √	WANG PART NUMBER 7775		
		SIZE D		DRAWING NUMBER 7775	
				REV. 12	

THIS DRAWING AND THE DATA SHOWN THEREON ARE THE CONFIDENTIAL PROPERTY OF, AND ARE PROPRIETARY TO, WANG LABORATORIES, INC. THIS DRAWING AND THE DATA SHOWN THEREON MAY NOT BE MADE PUBLIC WITHOUT THE WRITTEN CONSENT OF WANG LABORATORIES, INC. IF FOR ANY REASON THIS DRAWING IS PREMITTED BY WANG TO LEAVE THE PHYSICAL CUSTODY OF THE COMPANY, IT IS RETURNABLE UPON THE DEMAND OF WANG LABORATORIES, INC.

DO NOT SCALE

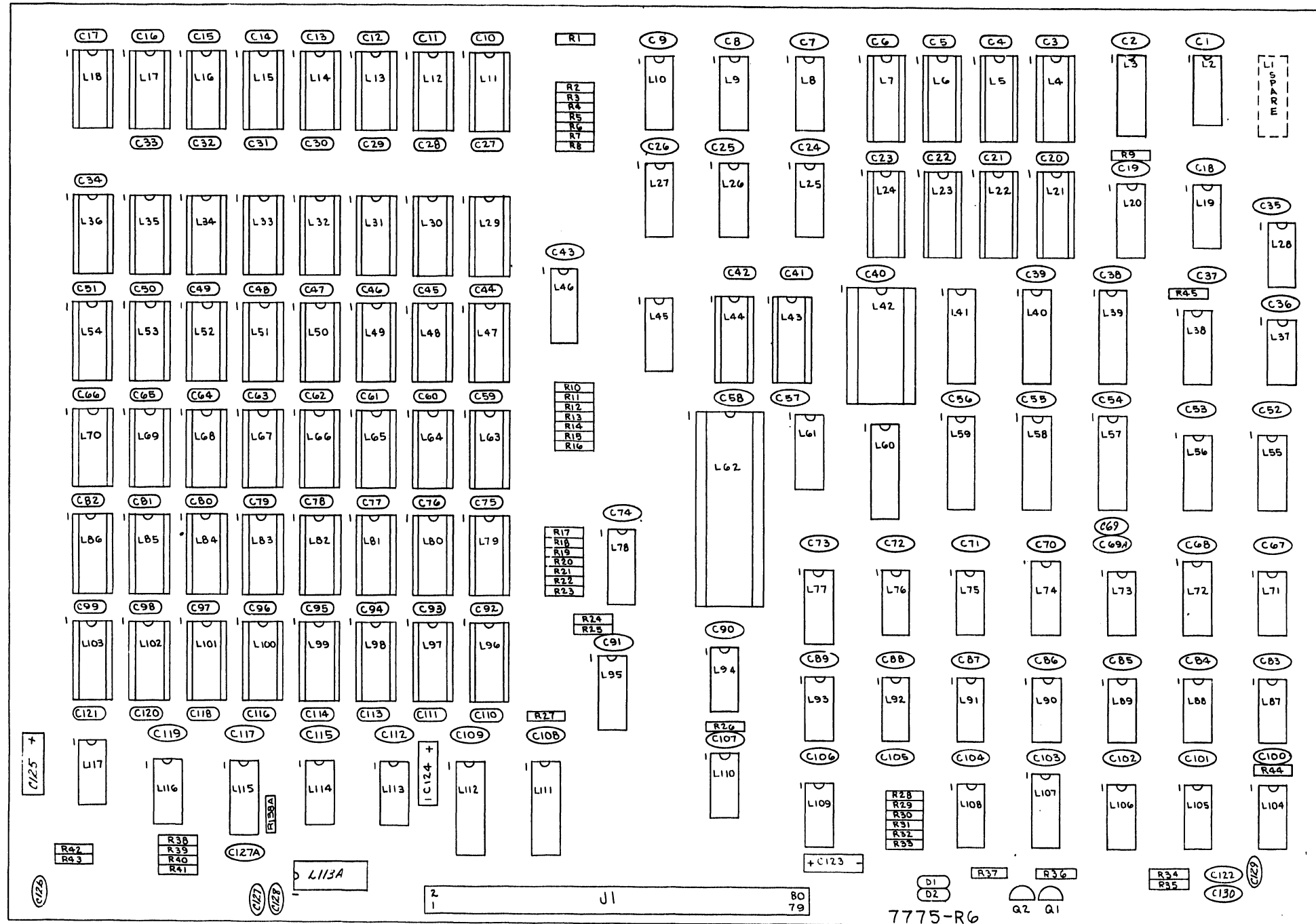

NO.	REVISION	DATE
	SEE SHEET 6	

WANG LABORATORIES, INC. LOWELL, MASS. U.S.A.		BY	DATE	APPROVED BY	DATE
MATERIAL		DWN L.D.B.	10-15-80	E ENGR	
MODEL NO. MWPS		CHK		M ENGR	
SEE ENGR. SPECIFICATIONS				MFG ENGR	
TITLE		CRT/MEMORY BOARD			
FINISH		TOL. EX. AS NOTED		210-7775 D 7775 ;2	
SCALE 1/8" = 1"		SHT 5 OF 6		WANG PART NUMBER SIZE DRAWING NUMBER REV	

11 10 9 8 7 5 4 3 2 1

THIS DRAWING AND THE DATA SHOWN THEREON ARE THE CONFIDENTIAL PROPERTY OF AND ARE PROPRIETARY TO WANG LABORATORIES, INC. THIS DRAWING AND THE DATA SHOWN THEREON MAY NOT BE REPRODUCED OR TRANSMITTED IN ANY FORM OR BY ANY MEANS, ELECTRONIC OR MECHANICAL, INCLUDING PHOTOCOPYING, RECORDING, OR BY ANY INFORMATION STORAGE AND RETRIEVAL SYSTEM, WITHOUT THE WRITTEN CONSENT OF WANG LABORATORIES, INC. IF FOR ANY REASON THIS DRAWING IS PERMITTED BY WANG TO LEAVE THE PHYSICAL CUSTODY OF THE COMPANY, IT IS RETURNABLE UPON THE DEMAND OF WANG LABORATORIES, INC.

DO NOT SCALE

I.C. LOCATION	TYPE	W. PART NO.
L1	SPARE	
L2, 2B	74LS32	376-0211
L4-7, 21-24, 43, 44	2114-L	SEE CHART
L8, L11, 2A	74LS157	376-0217
L9, 25, 26, 74	74LS298	376-0292
L10, 27, 45	74LS157	376-0216
L11-18, 29-36, 47-54, 63-70, 79-86, 96-103	MK4116/3	SEE CHART
L19	74LS393	376-0307
L20	7483	376-0018
L37, 71, 75	74LS04	376-0180
L38	74LS138	376-0294
L39, 57	74LS273	376-0302
L112	74LS373	376-0310
L42	2708	SEE CHART
L46, 78	74LS158	376-0301
L55	74160	376-0191
L56, 107	74LS175	376-0270
L58, 59	74LS245	376-0285
L60, 111	74LS244	376-0288
L61, 72	74166	376-0109
L62	VTAC-5027	SEE CHART
L73, 104, 113	74S02	376-0199
L76	74LS51	376-0213
L77	74LS155	376-0158
L87	74LS86	376-0271
L88	74LS27	376-0245
L89, 92	74LS00	376-0207
L90	7400	376-0002
L91, 114	74S04	376-0197
L93	74S20	376-0230
L94, 110	74S74	376-0202
L95	74S194	376-0221
L105	74S11	376-0237
L106	74S260	376-0206
L108	7406	376-0055
L109	74S32	376-0205
L115	74S139	376-0333
L116, 117	74S08	376-0200
L3	74LS175	376-0160
L4-7, 21-24, 43, 44	16 PIN SOCKET	376-9014
L11-18, 29-36, 47-54, 63-70, 79-86, 96-103	16 PIN SOCKET	376-9002
L42	24 PIN SOCKET	376-9003
L62	40 PIN SOCKET	376-9011
L40, 41	74LS374	376-0286

COMPONENT	TYPE	W. PART NO.
R1, 9, 26, 44, 45	4.7K 1/4W 5%	330-3048
R2-8, 10-23, 38-43	33Ω 1/4W 5%	330-1034
R24, 25, 34, 35	2.2Ω 1/4W 5%	330-1023
R27	1K 1/4W 5%	330-3011
R28	75Ω 1/4W 1%	330-0054
R29	150Ω 1/4W 5%	330-2016
R30	27Ω 1/4W 5%	330-1028
R32, 138A, 46	100Ω 1/4W 5%	330-2011
R33	470Ω 1/4W 5%	330-2048
R36, 37	5.1K 1/4W 5%	330-3052
R31	10Ω 1/4W 5%	330-1011
C1, 2, 7-9, 18, 19, 24-26, 35-40, 43, 52-53, 67-74, 83-91, 100-109, 112, 115, 117, 119, 126, 129	.047UF 50V	300-1966
C3-6, 10-17, 20-23, 27-34, 41, 42, 44-51, 59-66, 75-82, 92-99, 110, 111, 113, 114, 116, 118, 120, 121	.1UF 50V	300-1930
C122	.1UF 12V	300-1901
C123-125	15UF 20V	300-4022
C127	390 pf 500V	300-1390
D1, 2	SILICON	380-1001
Q1	MPS6514	375-1062
Q2	MPS6518	375-1014
C127A	150PF 500V	300-1150
J1	80 PIN CONN.	654-3006
SCREW	4/40 X 1/4	650-2087

MNEMONICS	COORD
BA0-BA3	2D11
BA4-BA6	2E11
BA7	3D11
BA8	2D11
BA9-BA12	2F11
BA13	2B11
BA14, BA15	369
BIORQ	3A11
BMREQ	3F11
BMT	3G11
BRD	2B11
BRFSH	3F11
BWR	2B11
CRT RAMSEL	2C11
DB0-DB7	2G4
HYSN	1F1
INIT	3A11
MC	3G10
PG0, PG1, PG3	3G6
PG2	3G3
POR	3F11
UM5	3G3
VSYN	1A7
VTAC	1G4

TYPE	I.C.	SPARES
74LS00	L89	2
	L117	1
74S02	L104	3
	L113	1
74S04	L91	4
	L114	5
74LS04	L37	1
	L71	1
	L75	4
74LS27	L88	1
74S32	L109	1
74LS32	L2	1
	L28	3
74LS51	L76	1
74S74	L110	1
74S86	L87	3

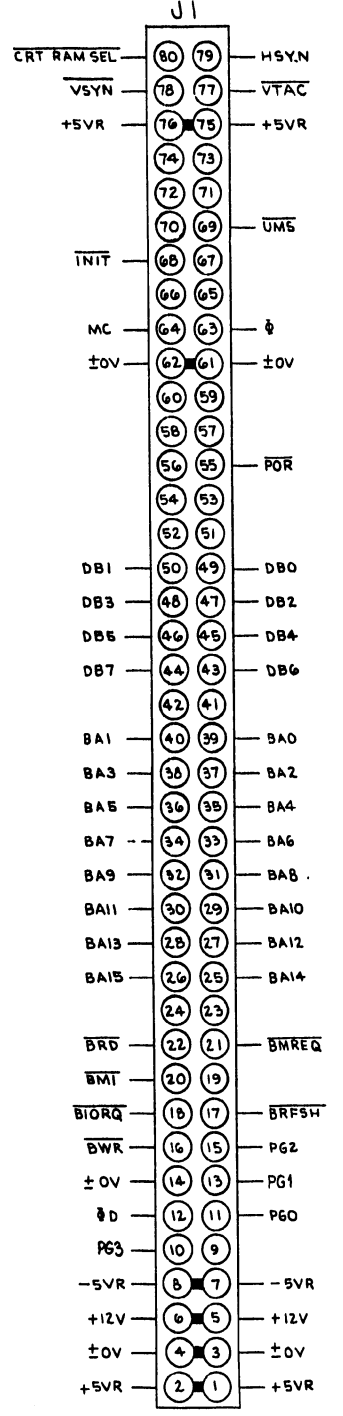

210=209+377 OR 378					
210	209	L4-7, 21-24, 43, 44	L11-18, 29-36, 47-54, 63-70, 79-86, 96-103	L42	L62
7775-A	7775	377-0341	377-0345	378-3035-R2	377-0372

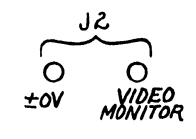
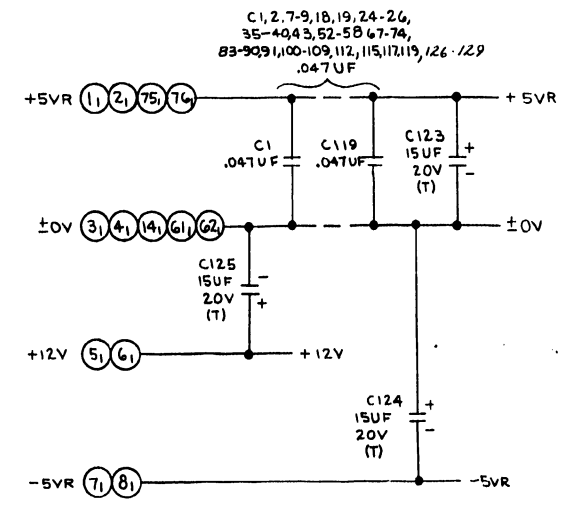

NOTE: ALL RES ARE 1/4W 5% UNLESS OTHERWISE SPECIFIED

E-REV 6

NO.	REVISION	ORIGINATED PER	DATE	DESIGNED BY	DATE	APPROVED BY	DATE	ECO#	APP'D.	DATE	ECO#	APP'D.	DATE	ECO#	APP'D.	DATE	ECO#	APP'D.	DATE	
1																				
2																				
3																				
4																				
5																				
6																				
7																				
8																				
9																				
10																				
11																				
12																				

WANG LABORATORIES, INC. LOWELL, MASS. U.S.A.		BY DWN	DATE 10 15 80	APPROVED BY E ENGR	DATE 10 15 80
MATERIAL ---		MODEL NO. MWPS		MFG ENGR	
FINISH ---		SEE ENGR. SPECIFICATIONS		TITLE CRT/MEMORY BOARD	
		210-7775 D		7775 12	
SCALE: 1:1		SHT 6 OF 6		WANG PART NUMBER 7775	

11 10 9 8 7 5 4 3 2 1

THIS DRAWING AND THE DATA SHOWN THERE ON ARE THE CONFIDENTIAL PROPERTY OF, AND ARE PROPRIETARY TO WANG LABORATORIES, INC. THIS DRAWING AND THE DATA SHOWN THEREON MAY NOT BE MADE PUBLIC WITHOUT THE WRITTEN CONSENT OF WANG LABORATORIES, INC. IF FOR ANY REASON THIS DRAWING IS PERMITTED BY WANG TO LEAVE THE PHYSICAL CUSTODY OF THE COMPANY, IT IS RETURNABLE UPON THE DEMAND OF WANG LABORATORIES, INC.

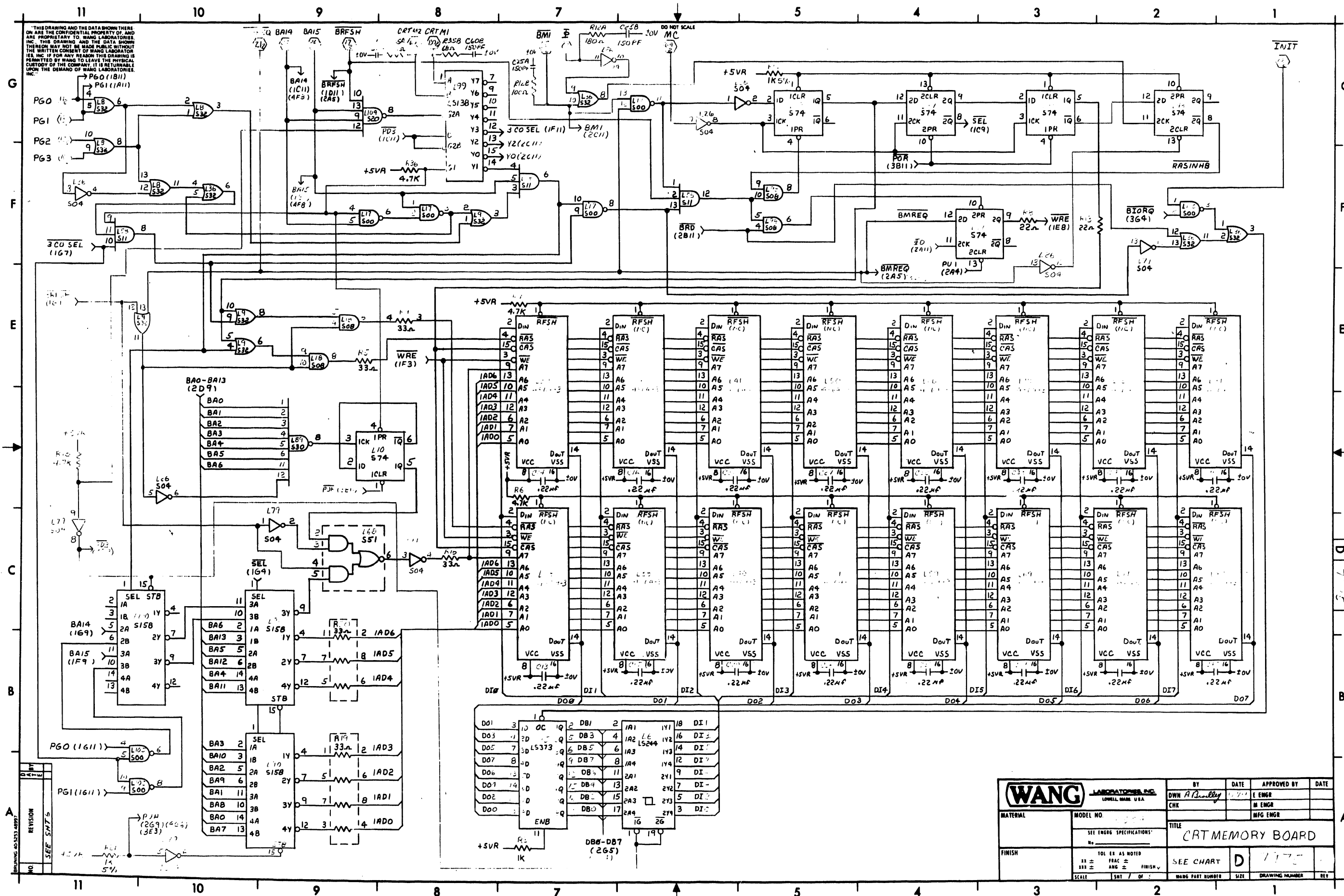

WANG LABORATORIES, INC. LOWELL, MASS. U.S.A.		BY DWN A. B. Bly	DATE 1/77	APPROVED BY M ENGR	DATE
MATERIAL		MODEL NO.		TITLE CRT MEMORY BOARD	
FINISH		SEE ENGR SPECIFICATIONS		SEE CHART	
SCALE		TOL. EX. AS NOTED		DRAWING NUMBER	
		11 ± 0.005		SIZE	
		10 ± 0.005		DRAWING NUMBER	
		9 ± 0.005		REV	
		8 ± 0.005			
		7 ± 0.005			
		6 ± 0.005			
		5 ± 0.005			
		4 ± 0.005			
		3 ± 0.005			
		2 ± 0.005			
		1 ± 0.005			

NO.	REVISION
1	SEE SMT-5

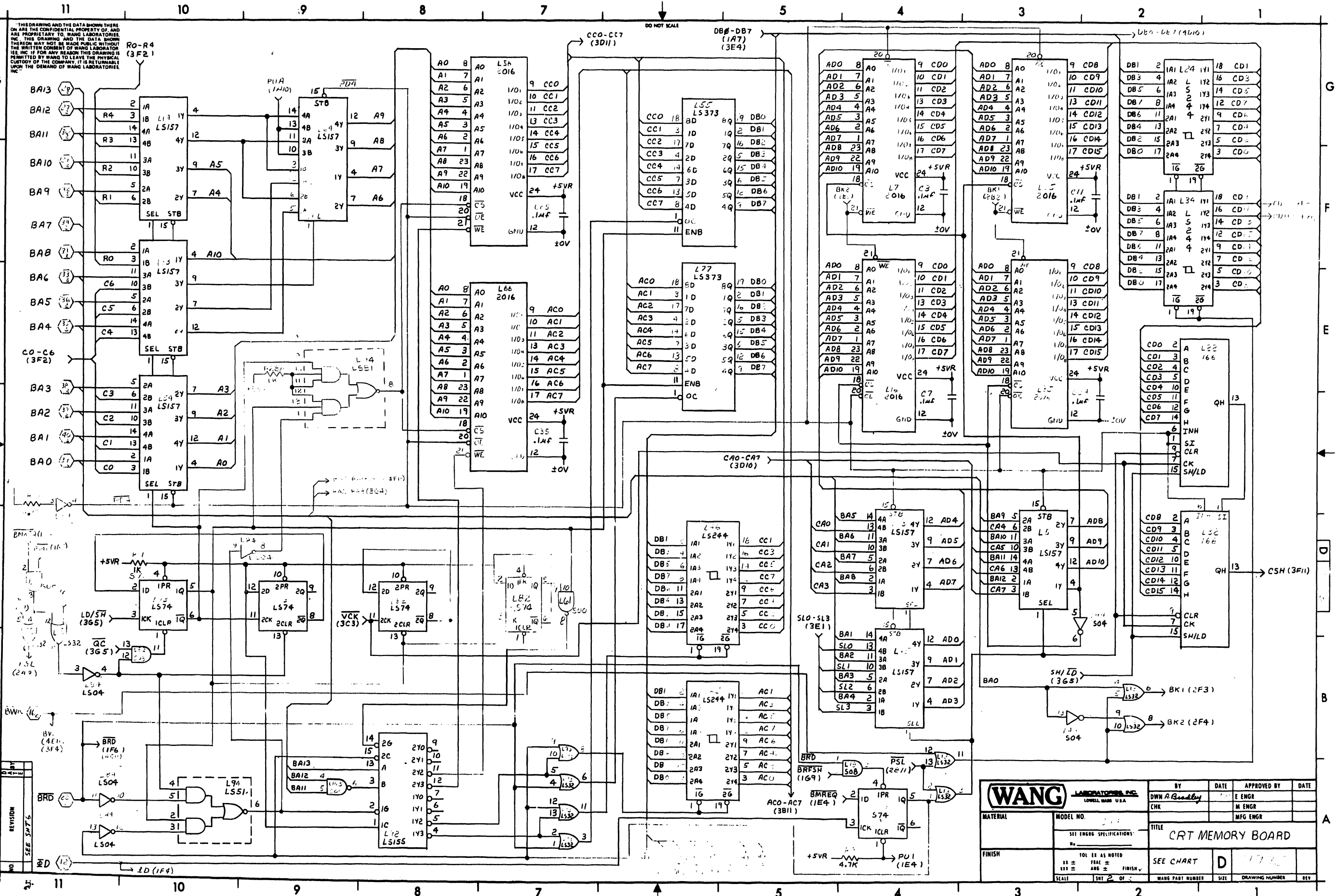

WANG LABORATORIES, INC. LOWELL, MASS. U.S.A.		BY DWN A. Boudley	DATE	APPROVED BY	DATE
MATERIAL		CHK		M. ENGR	
MODEL NO.		TITLE CRT MEMORY BOARD			
FINISH		SEE CHART			
SCALE		DRAWING NUMBER			
REV		REV			

REVISION
SEE 5276

NO. 11
11

THIS DRAWING AND THE DATA SHOWN THERE ON ARE THE CONFIDENTIAL PROPERTY OF, AND ARE PROPRIETARY TO, WANG LABORATORIES, INC. THIS DRAWING AND THE DATA SHOWN THEREON MAY NOT BE MADE PUBLIC WITHOUT THE WRITTEN CONSENT OF WANG LABORATORIES, INC. IF FOR ANY REASON THIS DRAWING IS PERMITTED BY WANG TO LEAVE THE PHYSICAL CUSTODY OF THE COMPANY, IT IS RETURNABLE UPON THE DEMAND OF WANG LABORATORIES, INC.

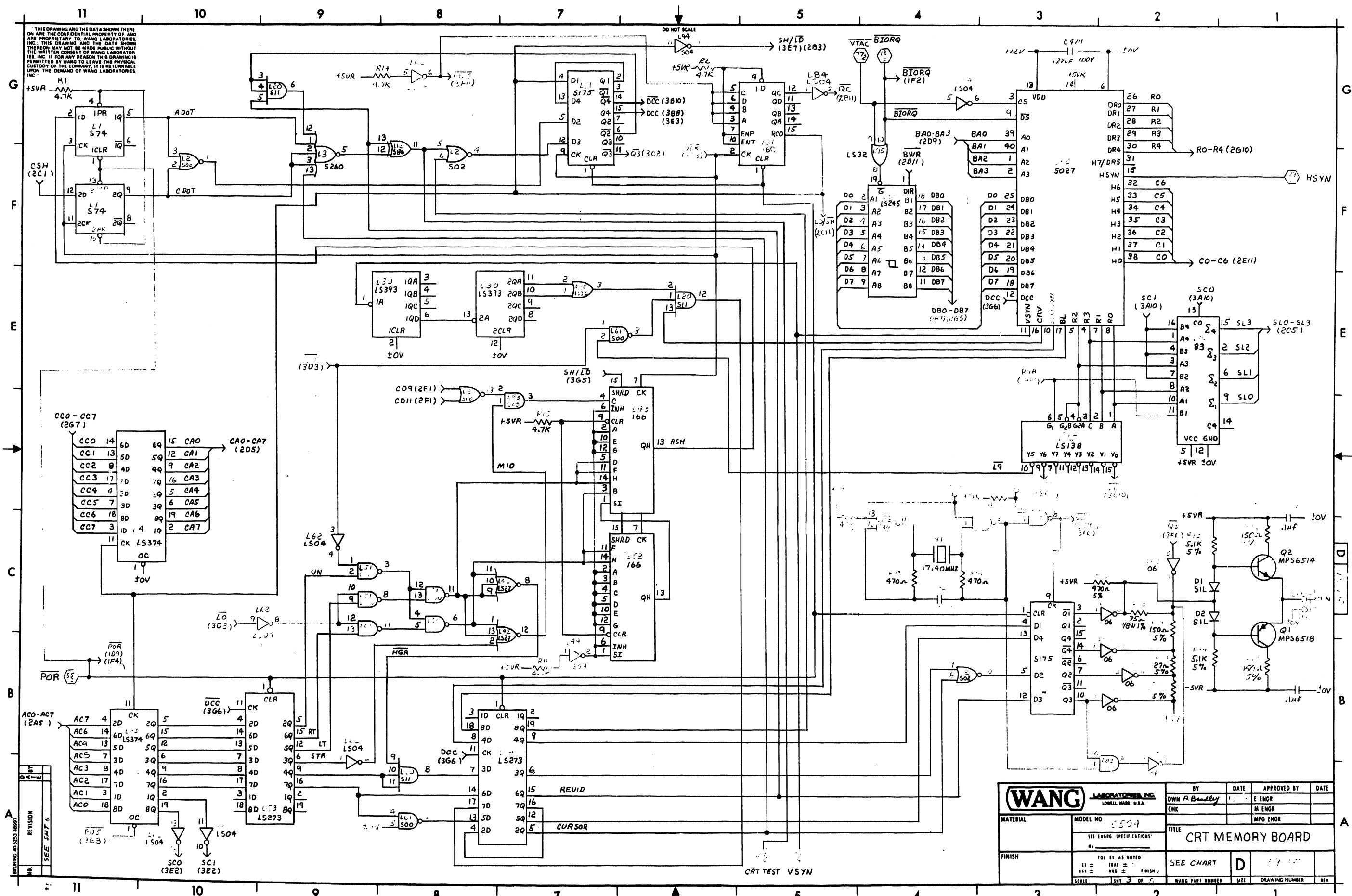

REV	REVISION
1	SEE INT'S

WANG LABORATORIES, INC. LOWELL, MASS. U.S.A.		BY DWN A. Bredley	DATE 1/2	APPROVED BY E ENGR	DATE
MATERIAL	MODEL NO. 5504	CHK		M ENGR	
SEE ENGRG. SPECIFICATIONS		TITLE CRT MEMORY BOARD			
FINISH TOL. AS NOTED XXX = FRAC ± XXX = ANG ±		SEE CHART	D		
SCALE SMT 3 OF 6	WANG PART NUMBER	SIZE	DRAWING NUMBER	REV	

THIS DRAWING AND THE DATA SHOWN THEREON ARE THE CONFIDENTIAL PROPERTY OF AND ARE PROPRIETARY TO WANG LABORATORIES, INC. THIS DRAWING AND THE DATA SHOWN THEREON MAY NOT BE MADE PUBLIC WITHOUT THE WRITTEN CONSENT OF WANG LABORATORIES, INC. IF FOR ANY REASON THIS DRAWING IS PERMITTED BY WANG TO LEAVE THE PHYSICAL CUSTODY OF THE COMPANY, IT IS RETURNABLE UPON THE DEMAND OF WANG LABORATORIES, INC.

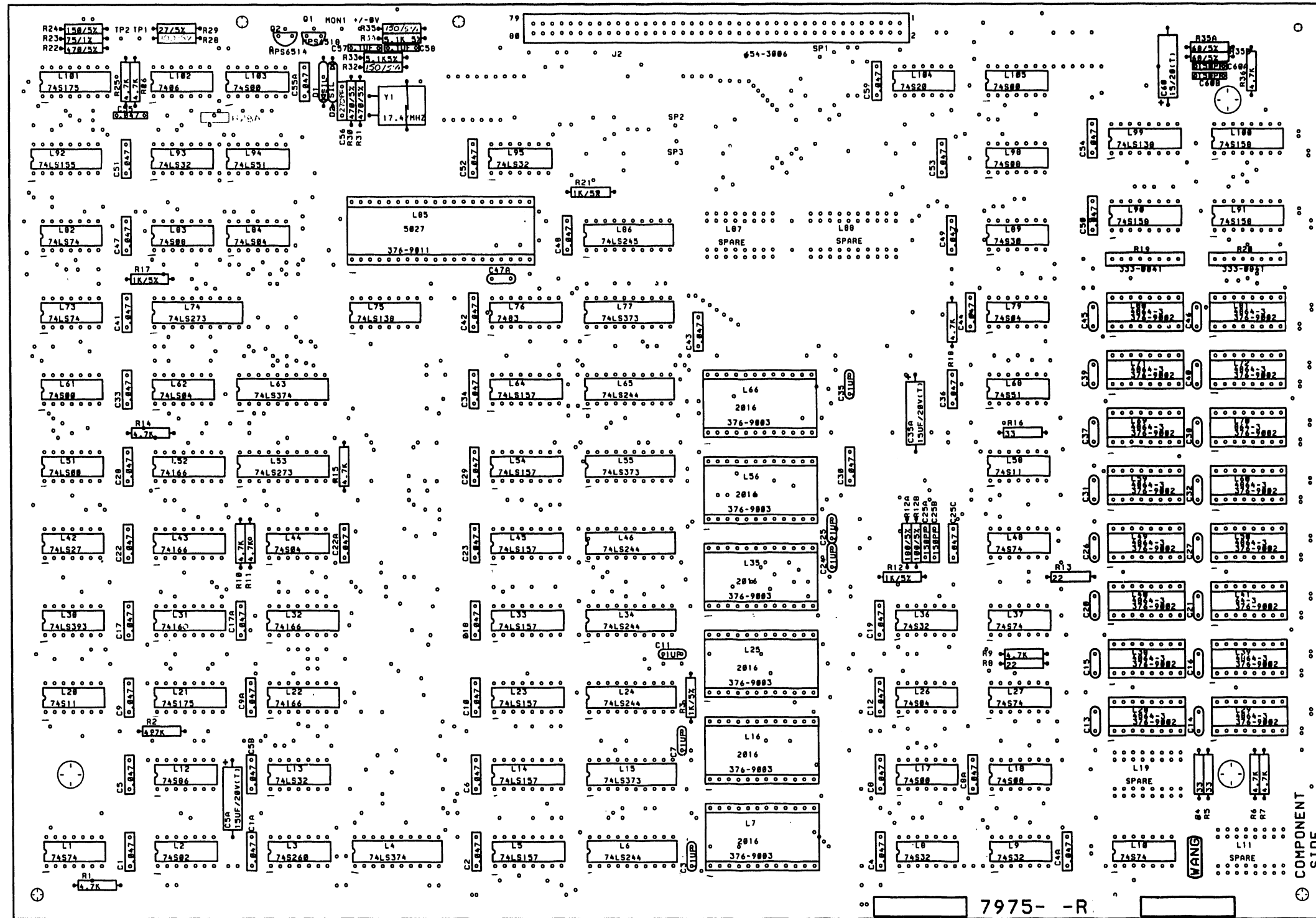

7975 - -R

NO.	REVISION	DATE	BY

SEE SHEET 5

WANG LABORATORIES, INC. LOWELL, MASS. U.S.A.		BY	DATE	APPROVED BY	DATE
MATERIAL	MODEL NO. 5504 SEE ENGR'S SPECIFICATIONS	DWN	5-16-68	E ENGR	
FINISH	101 IS AS NOTED 111 = 18AC 131 = ANG SCALE: 1/8" = 1" (1/4" OF 1/8")	CHK		M ENGR	
TITLE: CFT MEMORY BOARD		SEE CHART D		7975	
WANG PART NUMBER		SIZE	DRAWING NUMBER	REV.	

"THIS DRAWING AND THE DATA SHOWN THEREON ARE THE CONFIDENTIAL PROPERTY OF, AND ARE PROPRIETARY TO, WANG LABORATORIES, INC. THIS DRAWING AND THE DATA SHOWN THEREON MAY NOT BE REPRODUCED OR TRANSMITTED IN ANY FORM OR BY ANY MEANS, WITHOUT THE WRITTEN CONSENT OF WANG LABORATORIES, INC. IF FOR ANY REASON THIS DRAWING IS PERMITTED BY WANG TO LEAVE THE PHYSICAL CUSTODY OF THE COMPANY, IT IS RETURNABLE UPON THE DEMAND OF WANG LABORATORIES, INC."

DO NOT SCALE

I.C. LOCATION	TYPE	W.L. PART NO
L1,10,27,37,48,	74574	376-0202
L2	74502	376-0199
L3	745260	376-0206
L4,63	74LS374	376-0286
L5,14,23,33,45,54,64	74LS157	376-0216
L6,24,34,46,65	74LS244	376-0288
L7,16,25,35,56,66	2016	SEE CHART
L8,9,36	74532	376-0205
L11,19,87,88	SPAKE	
L12	74586	376-0271
L13,93,95	74LS32	376-0211
L15,55,77	74LS373	376-0310
L17,61,103,55	74500	376-0228
L18,83,98	74508	376-0200
L20,58	74511	376-0237
L21,101	745175	376-0270
L22,32,43,52	74166	376-0109
L26,44,79	74504	376-0197
L28,29,38-41,49,50,59,63,69-72,80,81	SEE CHART	
L30	74LS393	376-0307
L31	74160	376-0191
L42	74LS27	376-0245
L42,84	74LS04	376-0180
L51	74LS00	376-0207
L53,74	74LS273	376-0302
L63	74551	376-0184
L73,82	74LS74	376-0155
L75,99	74LS138	376-0294
L76	7483	376-0018
L85	5027	SEE CHART
L86	74LS245	376-0285
L89	74530	376-0198
L90,91,100	745158	376-0301
L92	74LS155	376-0158
L94	74LS51	376-0213
L102	7406	376-0055
L104	74520	376-0230
L7,16,25,35,56,66	24 PIN SKT	376-9003
L28,29,38-41,49,50,59,60,69-72,80,81	16 PIN SKT	376-9002
L85	40 PIN SKT	376-9011

COMPONENT	TYPE	W.L. PART NO
R1,2,6,7,9,10,11,14,15,18,25,26,36	4.7K 1/4W 5%	330-3048
R3,12,17,21,28A	1K 1/4W 5%	330-3011
R4,5,16	33Ω 1/4W 5%	330-1034
R8,13	22Ω 1/4W 10%	330-1022
R19,20	33Ω 51P	333-0841
R22,30,31	470Ω 1/4W 5%	330-2048
R23	75Ω 1/8W 1%	333-0054
R24,32,35	150Ω 1/4W 5%	330-2016
R12B,28	100Ω 1/4W 5%	330-2011
R29	27Ω 1/4W 5%	330-1028
R12A	180Ω 1/4W 5%	330-2019
R33,34	5.1K 1/4W 5%	330-3052
R35A,35B	68Ω 1/4W 5%	330-1064
C1,1A,2,4,4A,5,5B,6,8,8A,9,9A,10,12,17,17A,18,19,22,22A,23,25C,28-30,33,34,36,41-44,47-55,55A,59	.047 50V	300-1705
C3,7,11,24,25,35	.1MF 50V H.F.	300-1930
C13-16,20,21,26,27,31,32,37-40,45,46,47A	.22MF 100V	300-1926
C5A,55A,60	.1MF 20V (T)	300-4022
C51,58	.1MF 12V	300-1901
C25A,25B,60A,60B	.150PF	300-1900
D1,2	SIL D035	380-1001
Q1	MPS 6518	375-1014
Q2	MPS 6514	375-1062
Y1	17.40MHZ	321-0029
J1	BNC SOCKET-F	350-1036
J2	80 PIN CUNN	654-3006

TYPE	LOCATION	SPACE
74504	L79	/
74508	L18	/
	L83	/
	L93	/
74500	L105	/
74527	L42	/
74520	L104	/
74551	L68	/
74574	L10	/
74586	L12	3
74504	L11	/
745260	L3	/

MNEMONIC	COUNT
BA0-BA13	2011
BA14	169
BA15	169
BA16	364
BA17	167
BA18	1610
BA19	3411
BA20	169
BA21	2811
BA22	168
BA23	168
BA24	345
BA25	246
BA26	3F1
BA27	2411
BA28	167
BA29	161
BA30	166
BA31	1611
BA32	3811
BA33	345
BA34	365

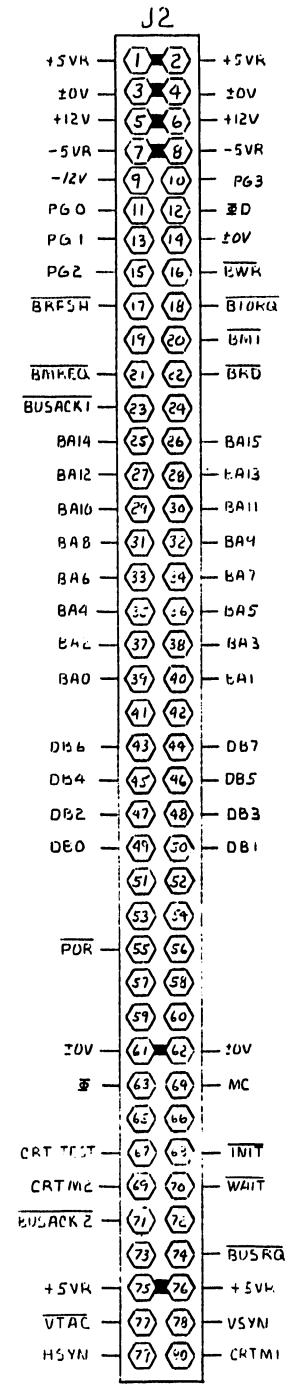

210 = 201 + 377 ON 378, 397				
210	209	L7,16,25,35,56,66	L28,29,38-41,49,50,59,60,69-72,80,81	L85
7975-A	7175	397-0433	377-041E	377-0372

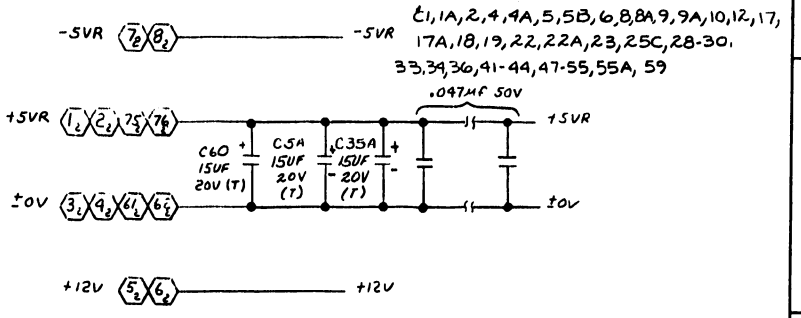

NOTE ALL RES ARE 1/4W 5% UNLESS OTHERWISE SPECIFIED.

NO	REVISION	DATE	BY	CHK	APP'D	DATE	BY	CHK	APP'D	DATE	BY	CHK	APP'D
1	ORIGINAL PER DIV# E1370	11/18/81											
2	REVISED PER DIV# E1370	12/18/81											
3	REVISED PER DIV# E1370	2-25-82											
4	REVISED PER DIV# E1370	3-31-82											
5	REVISED PER DIV# E1370	4-22-82											
6	REVISED PER DIV# E1370	5-17-82											
7	REVISED PER DIV# E1370	6-7-82											
8	REVISED PER DIV# E1370	11/20/82											
9	REVISED PER DIV# E1370	12/10/82											
10	REVISED PER DIV# E1370	5-19-83											
11	REVISED PER DIV# E1370	5-11-83											

WANG LABORATORIES, INC. LOWELL, MASS. U.S.A.		BY DWN L. ...	DATE 11/18/81	APPROVED BY E ENGR ...	DATE ...
MATERIAL		MODEL NO. 4504		TITLE CRT MEMORY BOARD	
FINISH		TOL EX AS NOTED		SCALE 1:1	
DRAWING NUMBER 7975		SIZE D		REV 11	

THIS DRAWING AND THE DATA SHOWN THEREON ARE THE CONFIDENTIAL PROPERTY OF, AND ARE PROPRIETARY TO, WANG LABORATORIES, INC. THIS DRAWING AND THE DATA SHOWN THEREON MAY NOT BE MADE PUBLIC WITHOUT THE WRITTEN CONSENT OF WANG LABORATORIES, INC. IF FOR ANY REASON THIS DRAWING IS PERMITTED BY WANG TO LEAVE THE PHYSICAL CUSTODY OF THE COMPANY, IT IS RETURNABLE UPON THE DEMAND OF WANG LABORATORIES, INC.

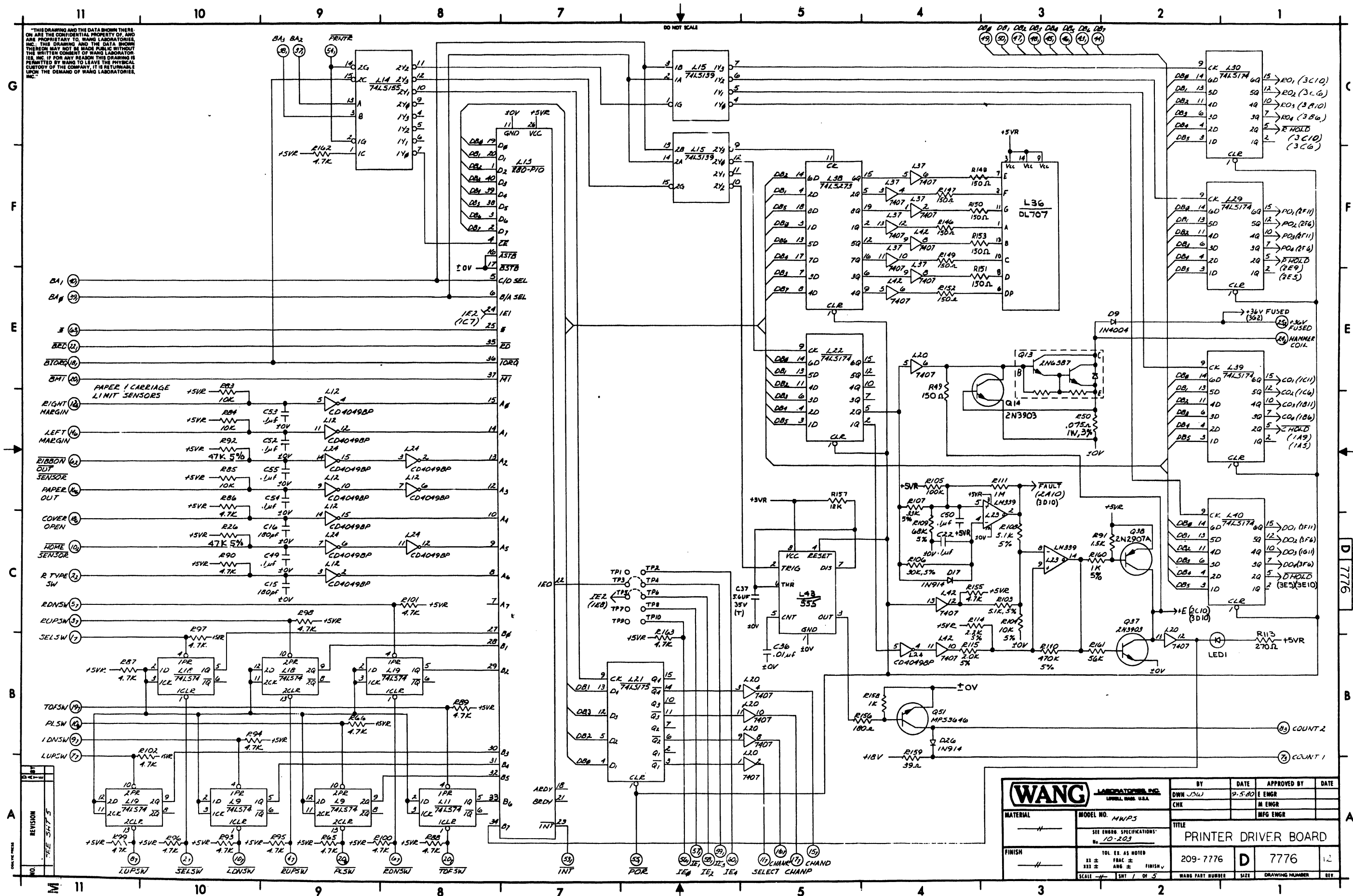

WANG LABORATORIES, INC.		BY	DATE	APPROVED BY	DATE
LABORATORIES, INC. U.S.A.		DWN JSW	9-5-80	E ENGR	
MATERIAL		CHK		M ENGR	
MODEL NO. MNP5		TITLE		MFG ENGR	
SEE ENGR SPECIFICATIONS No. 10-203		PRINTER DRIVER BOARD			
FINISH		TOL. EX. AS NOTED	209-7776	D	7776
		± .015 ± .030 ± .005 ± .002	SIZE	12	12
SCALE 1/8" = 1"		WANG PART NUMBER		SIZE	DRAWING NUMBER
		10-203		12	7776

"THIS DRAWING AND THE DATA SHOWN THEREON ARE THE CONFIDENTIAL PROPERTY OF, AND ARE PROPRIETARY TO, WANG LABORATORIES, INC. THE DRAWING AND THE DATA SHOWN THEREON MAY NOT BE MADE PUBLIC WITHOUT THE WRITTEN CONSENT OF WANG LABORATORIES, INC. IF FOR ANY REASON THIS DRAWING IS PERMITTED BY WANG TO LEAVE THE PHYSICAL CUSTODY OF THE COMPANY, IT IS RETURNABLE UPON THE DEMAND OF WANG LABORATORIES, INC."

DO NOT SCALE

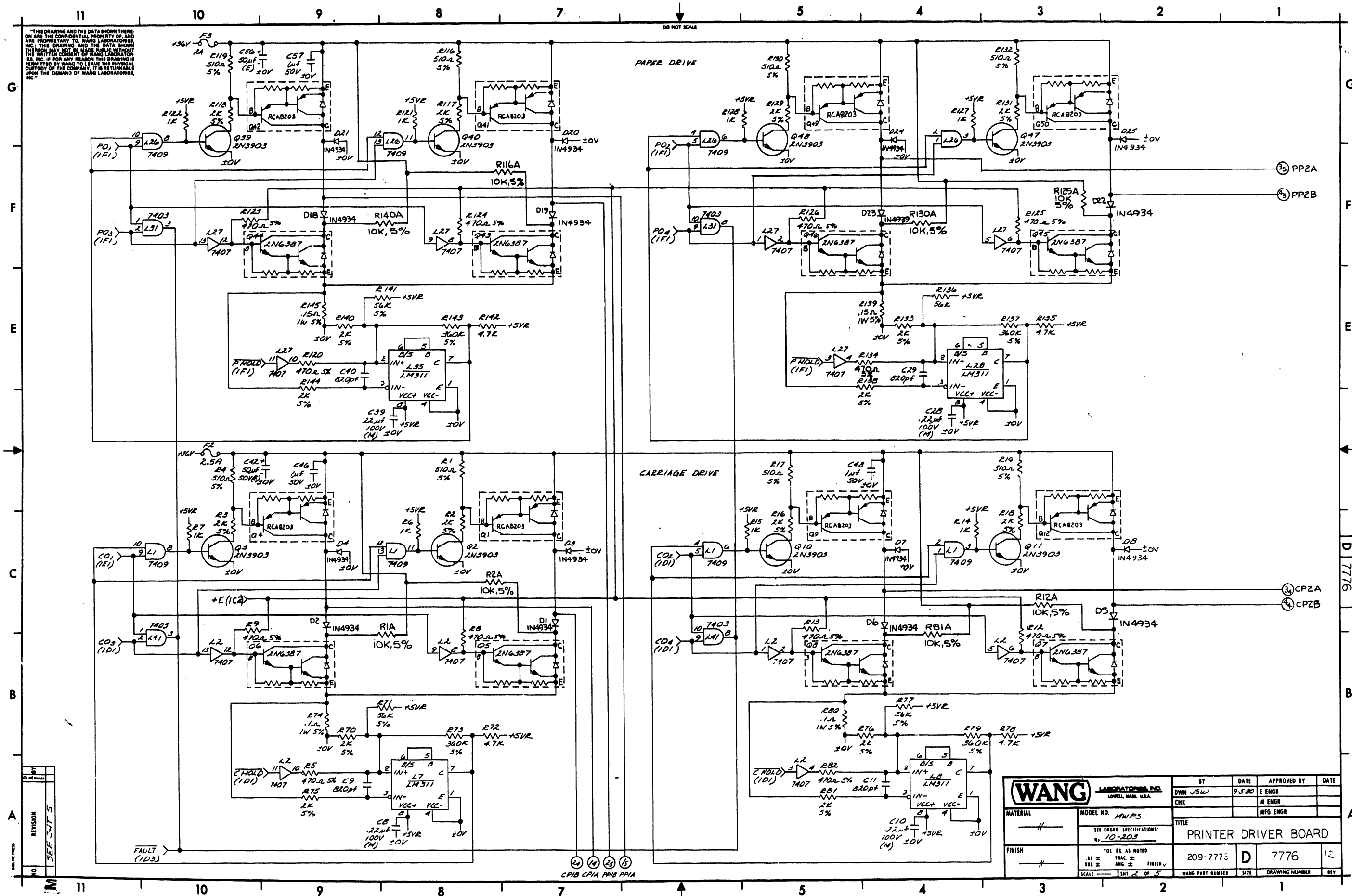

WANG LABORATORIES, INC. LOWELL, MASS. U.S.A.		BY DWN JSW	DATE 9.5.80	APPROVED BY E ENGR	DATE
MATERIAL —		CHK M ENGR	TITLE PRINTER DRIVER BOARD		
FINISH —		SCALE 1:1		WANG PART NUMBER 209-777E	REV 12
MODEL NO. MWPS		SIZE D		DRAWING NUMBER 7776	
SEE ENGR SPECIFICATIONS No. 10-203		TOL. ET. AS NOTED XX ± XXX ± SCALE		SHT. 2 OF 5	

NO.	REVISION
1	SEE SHT 5

CP1B CP1A PP1B PP1A

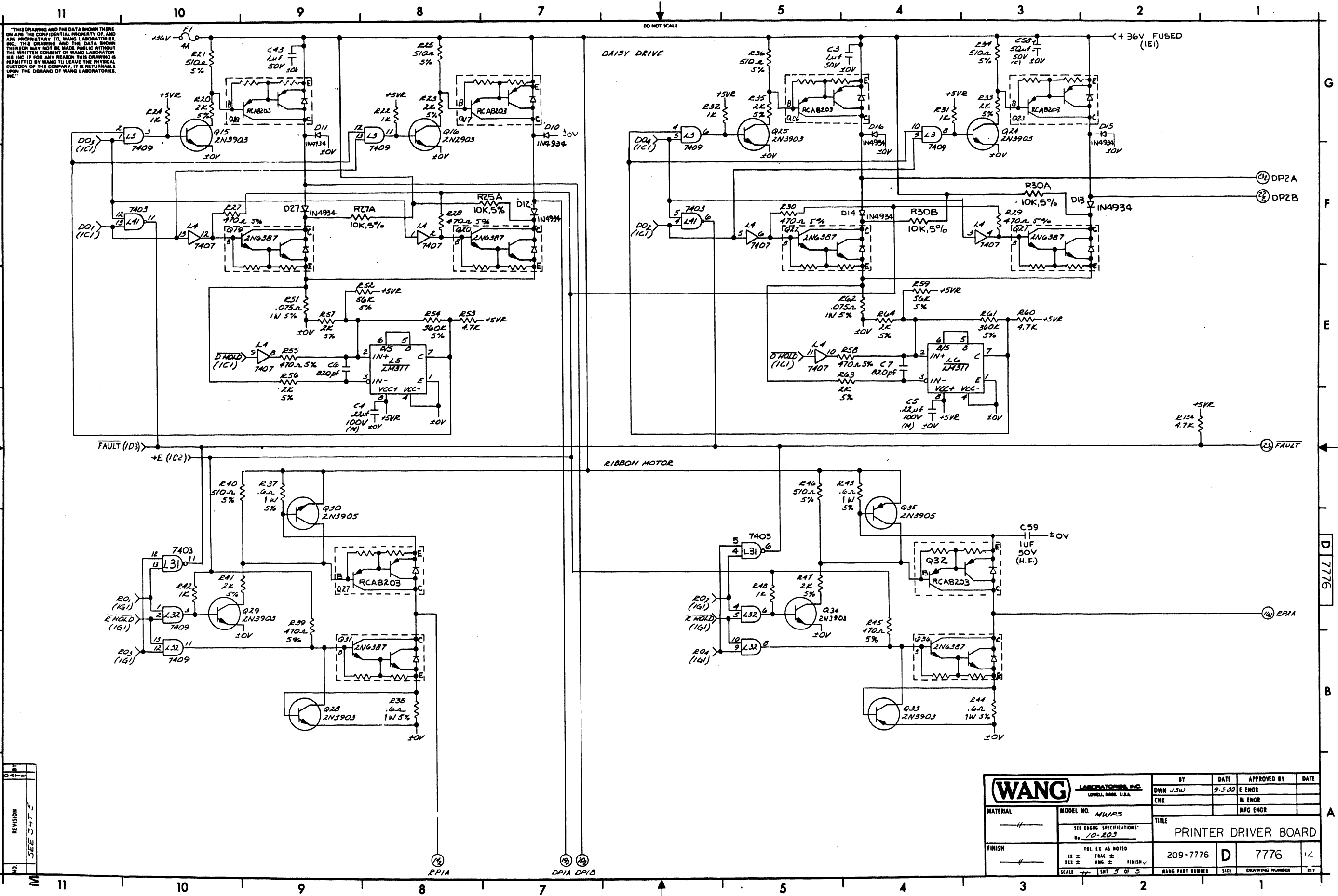

"THIS DRAWING AND THE DATA SHOWN THERE ON ARE THE CONFIDENTIAL PROPERTY OF, AND ARE PROPRIETARY TO, WANG LABORATORIES, INC. THIS DRAWING AND THE DATA SHOWN THEREIN MAY NOT BE MADE PUBLIC WITHOUT THE WRITTEN CONSENT OF WANG LABORATORIES, INC. IF FOR ANY REASON THIS DRAWING IS PERMITTED BY WANG TO LEAVE THE PHYSICAL CUSTODY OF THIS COMPANY, IT IS RETURNABLE UPON THE DEMAND OF WANG LABORATORIES, INC."

DO NOT SCALE

NO.	REVISION

WANG LABORATORIES, INC. LOWELL, MASS. U.S.A.		BY DWN J.S.W.	DATE 9-5-80	APPROVED BY E ENGR	DATE
MATERIAL —		MODEL NO. NK1P5	TITLE PRINTER DRIVER BOARD		
FINISH —		SEE ENGR. SPECIFICATIONS No. 10-203	209-7776 D 7776 12		
SCALE 1/8" = 1"		TOL. AS NOTED XX ± XXX ± ANG ± FINISH √	WANG PART NUMBER 209-7776		
SHEET 3 OF 5		SIZE D		REV 12	

THIS DRAWING AND THE DATA SHOWN THEREON ARE THE CONFIDENTIAL PROPERTY OF, AND ARE PROPRIETARY TO, WANG LABORATORIES, INC. THIS DRAWING AND THE DATA SHOWN THEREON MAY NOT BE MADE PUBLIC WITHOUT THE WRITTEN CONSENT OF WANG LABORATORIES, INC. IF FOR ANY REASON THIS DRAWING IS PERMITTED BY WANG TO LEAVE THE PHYSICAL CUSTODY OF THE COMPANY, IT IS RETURNABLE UPON THE DEMAND OF WANG LABORATORIES, INC.

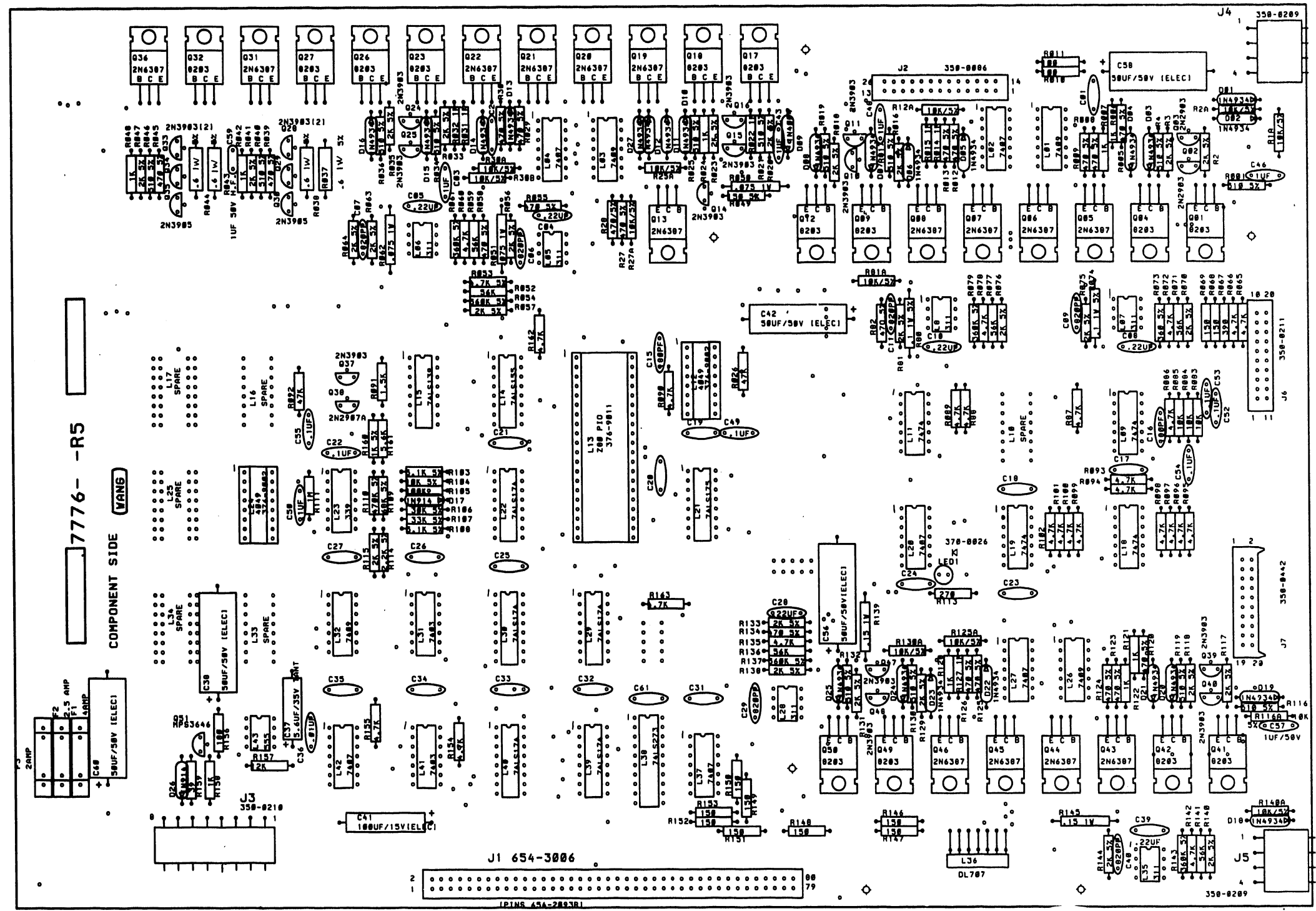

NO	REVISION
	SEE CHG 5

WANG LABORATORIES, INC. LOWELL, MASS. U.S.A.		BY	DATE	APPROVED BY	DATE
MATERIAL		DWN		E ENGR	
MODEL NO. 7776-R5		CHK		M ENGR	
SEE ENG'S SPECIFICATIONS				MIG ENGR	
FINISH		TITLE: PRINTER DRIVER 500			
TOL IS AS NOTED		7776-R5	D	70	
FRAC ±					
ANG ±					
FINISH					
SCALE					
SHT. 1 OF 5		WANG PART NUMBER	SIZE	DRAWING NUMBER	REV

THIS DRAWING AND THE DATA SHOWN THEREON ARE THE CONFIDENTIAL PROPERTY OF WANG AND ARE PROPRIETARY TO WANG LABORATORIES, INC. THIS DRAWING AND THE DATA SHOWN THEREON MAY NOT BE MADE PUBLIC WITHOUT THE WRITTEN CONSENT OF WANG LABORATORIES, INC. IF FOR ANY REASON THIS DRAWING IS PRINTED BY WANG TO LEAVE THE PHYSICAL CUSTODY OF THE COMPANY, IT IS RETURNABLE UPON THE DEMAND OF WANG LABORATORIES, INC.

IC LOCATION	TYPE	W.L. PART NO.
L1,3,26,32	7409	376-0085
L2,4,20,27,37,42	7407	376-0056
L5,6,7,8,28,35	LM311	376-0474
L9,11,18,19	74LS74	376-0155
L12,24	CD4049BP	376-0376
L13	850-P10	SEE CHART
L14	74LS155	376-0158
L15	74LS139	376-0226
L21	74LS175	376-0160
L22,29,30,38,40	74LS174	376-0159
L23	LM339	376-0240
L31,41	7403	376-0028
L36	DL707	340-0017
L38	74LS273	376-0302
L43	555	376-0126
L13	40 PIN SKT	376-9011
L10,16,17,25,33,34	SPARE	

TYPE	IC LOCATION	SPARES
7407	L42	2
74LS74	L11	1
CD4049BP	L24	1
LM339	L23	2

COMPONENT	TYPE	W.L. PART NO.
R1,4,17,19,21,25,34,36,40,46,116,119,130,132	510Ω 1/4W 5%	330-2052
R2,3,16,18,20,23,33,35,41,47,56,57,63,64,70,75,76,81,115,117,118,129,131,133,138,140,144	2K 1/4W 5%	330-3021
R5,8,9,12,13,27,28,29,30,39,45,55,58,82,120,123,124,125,126,134	470Ω 1/4W 5%	330-2048
R6,7,14,15,22,24,31,32,42,48,121,122,127,128,152	1K 1/4W 10%	330-3010
R10,11	100Ω 1/4W 10%	330-2010
L26,32	47K 1/4W 5%	330-4048
R3,6,10,65,66,72,78,86,90,93,102,135,142,154,155,162,163	4.7K 1/4W 10%	330-3047
R37,38,43,44	.6Ω 1W 5%	334-0054
R50	.075Ω 1W 3%	334-0053
R51,62	.075Ω 1W 5%	334-0052
R52,59,71,77,136,141	56K 1/4W 10%	330-4056
R160	1K 1/4W 5%	330-3011
R54,61,73,79,137,143	360K 1/4W 5%	330-5037
R67	390Ω 1/4W 10%	330-2039
R68,69,146-153,149	150Ω 1/4W 10%	330-2015
R1A,2A,12A,25A,27A,30A,30B,61A,116A,125A,130A,140A	10K 1/4W 5%	330-4011
R74,80	.1Ω 1W 5%	334-0056
R83,84,85,104	10K 1/4W 10%	330-4010
R91	1.5K 1/4W 10%	330-3015
R103,108	5.1K 1/4W 5%	330-3052
R105	100K 1/4W 10%	330-3010
R106	30K 1/4W 5%	330-4031
R107	33K 1/4W 5%	330-4034
R109	68K 1/4W 5%	330-4069
R110	470K 1/4W 5%	330-5018
R111	1M 1/4W 10%	330-6010
R113	270Ω 1/4W 10%	330-2027
R114	2.2K 1/4W 5%	330-3023
R156	180Ω 1/4W 10%	330-2018
R157	12K 1/4W 10%	330-4012
R159	39Ω 1/4W 10%	330-1039
R161	5.6K 1/4W 10%	330-3056
C1,2,17-21,23-27,31-35,61	.047UF 50V	300-1966
C3,4,3,16,48,50,57,59	1μf (H.F.)	300-1931
C4,5,8,10,28,39	.22μf 100V 20%	300-1926
C6,7,9,11,29,40	.820pf 500V 10%	300-1820
C15,16	180pf 500V 10%	300-1180
C22,49,52-55	1μf 50V +80-20%	300-1930
C36	.01μf 25V +80-20%	300-1903
C37	5.6μf 35V 10%(T)	300-4017
C38,42,56,58,60	30μf 50V +75-10%(E)	300-3010
C41	100μf 16V +75-10%(E)	300-3011

COMPONENT	TYPE	W.L. PART NO.
C59	1μf 50V (H.F.)	300-1931
D1-8,10-16,18-25,27	1N4934	380-4011
D9	1N4004 RECT 400V/M	380-4000
D17,26	1N934SIGNAL 75PEV	380-1012
LED1	LED RED	370-0026
Q1,4,9,12,17,18,26,27,32,41,42,49,50	2N6203 PNP	375-1053
Q5-8,13,19-22,31,36,43-46	2N6387 NPN	375-1052
Q9,34,47-49,23,24,25,28,29,33,34,37,39,40,47,48	2N3903 PNP	375-1068
Q30,35	2N3905 PNP	375-1069
Q51	2N3646	375-1004
Q38	2N2907A	375-1059
F1	4AMP PICO 125V	360-1156
F3	2 AMP PICO 125V	360-1155
F2	2.5AMP PICO 125V	360-1153
J1	CONN, 80 PIN	654-3006
J2	CONN, 26 PIN	350-0006
J3	CONN, 8 PIN	350-0210
J4,5	CONN, 4 PIN	350-0209
J6	CONN, 20 PIN	350-0211
J7	CONN, 20 PIN	350-0442

MNEMONIC	COORD	MNEMONIC	COORD	MNEMONIC	COORD
BA8	1E11	IE8	1A6	RMSV	5B11
BA1	1E11	IE1	1A6	ROSV	5B11
BA2	1A9	IE2	1A6	RPIA	3A8
BA3	1A9	IE3	1A6	RP2A	3C1
BIORQ	1E11	IE4	1A6	R TYPE SW	1C11
BP7	1E11	INT	1A7	RUPSW	1C11
BD	1E11	#	1E11	RUPSW	1A9
CHAND	1A5	LDNSW	1B11	SELECT	1A5
CHAMP	1A5	RDNSW	1A10	SELNSW	1B11
CHANR	1A5	LEFT MARGIN	1D11	SELNSW	1A10
COUNT 1	1A1	LMSV	5B11	TDFSW	1B11
COUNT 2	1B1	LUPSW	1A11	TDFSW	1A8
COVER OPEN	1C11	LUPSW	1A11		
CP1A	2A7	PAPER OUT	1D11		
CP1B	2A7	PLSW	1B11		
CP2A	2C1	PLSW	1A9		
CP2B	2C1	POR	1A6		
DB4-DB7	1A3	POSV	5B11		
DP1A	3A7	RPIA	2A6		
DP1B	3A7	RP1B	2A7		
DP2A	3F1	RP2A	2F1		
DP2B	3F1	RP2B	2F1		
FAULT	3D1	RENTE	1A9		
HAMMER COIL	1E1	RDNSW	1C11		
HOME SENSOR	1C11	RDNSW	1A8		
HSSV	5B11	RIBBON OUT SENSOR	1D11		
		RIGHT MARGIN	1D11		

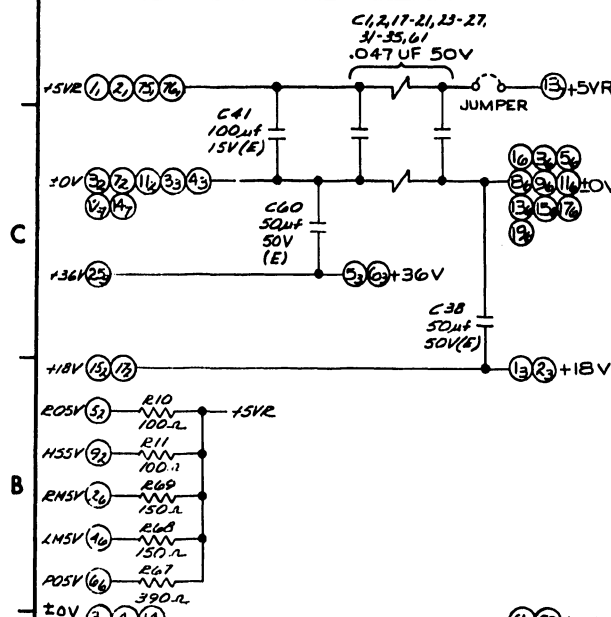

REVISION	DATE	BY	DESCRIPTION
1	10-1-77	JSW	REVISED PER ECO # 1776
2	10-1-77	JSW	REVISED PER ECO # 1776
3	10-1-77	JSW	REVISED PER ECO # 1776
4	10-1-77	JSW	REVISED PER ECO # 1776
5	10-1-77	JSW	REVISED PER ECO # 1776
6	10-1-77	JSW	REVISED PER ECO # 1776
7	10-1-77	JSW	REVISED PER ECO # 1776
8	10-1-77	JSW	REVISED PER ECO # 1776
9	10-1-77	JSW	REVISED PER ECO # 1776
10	10-1-77	JSW	REVISED PER ECO # 1776
11	10-1-77	JSW	REVISED PER ECO # 1776
12	10-1-77	JSW	REVISED PER ECO # 1776

210 = 209 + 377 OR 378
7776A 7776 377-0378

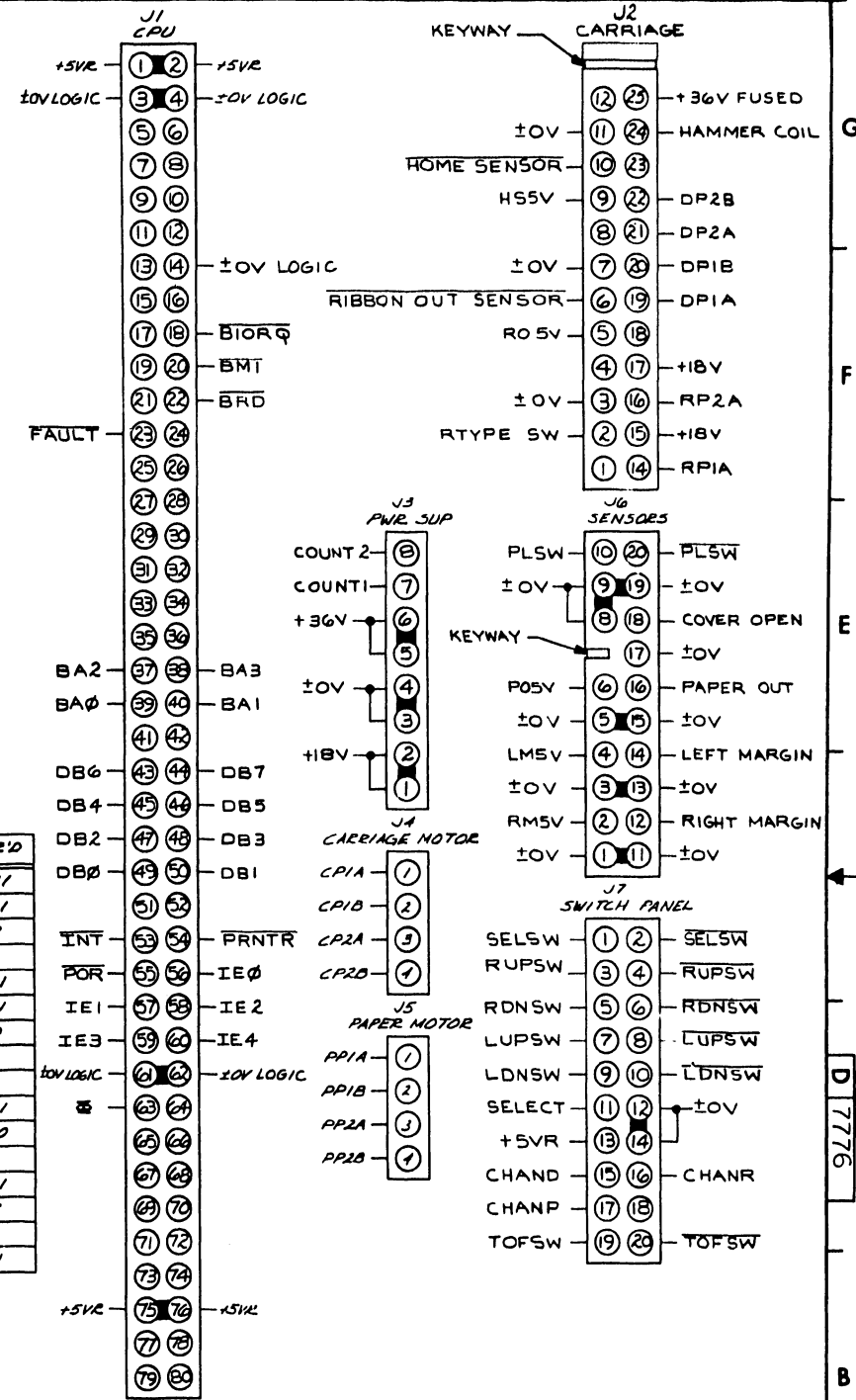

WANG LABORATORIES, INC. LIMELIGHT, MASS. U.S.A.		BY	DATE	APPROVED BY	DATE
MODEL NO. MWPS		DWN JSW	9-5-80	E ENGR	10-7-80
SEE ENGINE SPECIFICATIONS # 10-103		CHK	11/1/80	M ENGR	
TITLE		PRINTER DRIVER BOARD			
FINISH		209-7776		D	7776
SCALE		SHEET 5 OF 5		DRAWING NUMBER	